

AMC

SERVICE MANUAL

3100a

STEREO INTEGRATED AMPLIFIER

CONTENTS

DESCRIPTION	PAGE
SPECIFICATIONS	3
REAR PANEL CONNECTIONS/FRONT PANEL CONTROLS	4
AMPLIFIER ADJUSTMENT	5
SCHEMATIC DIAGRAM	6-8
PCB LAYOUT.....	9-12
MAINS WIRING INSTRUCTION	13
SERVICE PARTS LIST	14-16

SPECIFICATIONS

Output power:

Rated Power into 8 ohm (With both channels driven) 100W
1KHz clipping power into 8 ohm 110W

Rated T.H.D.+ Noise:

20Hz-20Khz 0.03%

Input sensitivity for 1W/Rated Power into 8 ohms:

High level inputs 15mV/200mV

Input impedance:

High level inputs 20K ohms

Frequency response:

Tone bypass 20Hz-20Khz +/-0.2dB
Normal 20Hz-20Khz +/-0.5dB
High level inputs -3dB <10Hz/>100KHz

Signal to noise ratio (ref. 1W/8 ohms):

High level inputs "A" WTD 85dB
Separation 20Hz-20Khz 75dB

Tone control range:

Bass at 100Hz +/-9dB
Treble at 10Khz +/-8dB

OTHERS:

Dimensions (WxHxD) 430x112x288mm
Net weight 10.8Kg
Shipping weight (2 pieces) 23.2Kg

REAR PANEL CONNECTIONS/FRONT PANEL CONTROLS

REAR PANEL

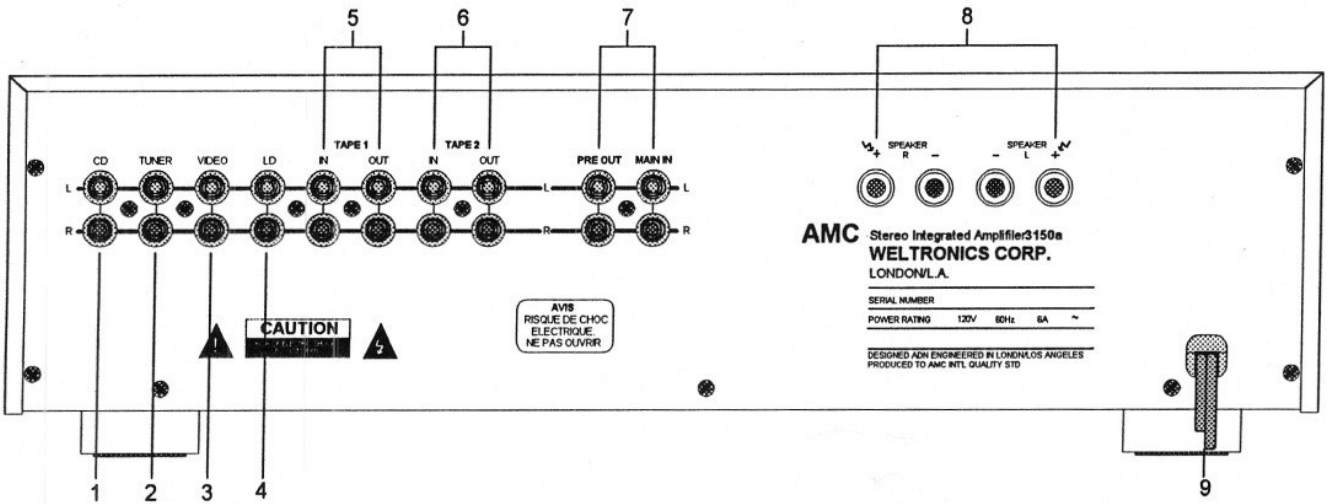

1. CD INPUT
2. TUNER INPUT
3. VIDEO INPUT
4. LD INPUT
5. TAPE1 IN/OUT

6. TAPE2 IN/OUT
7. PRE OUT/MAIN IN
8. LOUDSPEAKER TERMINALS
9. AC LINE CORD

FRONT PANEL

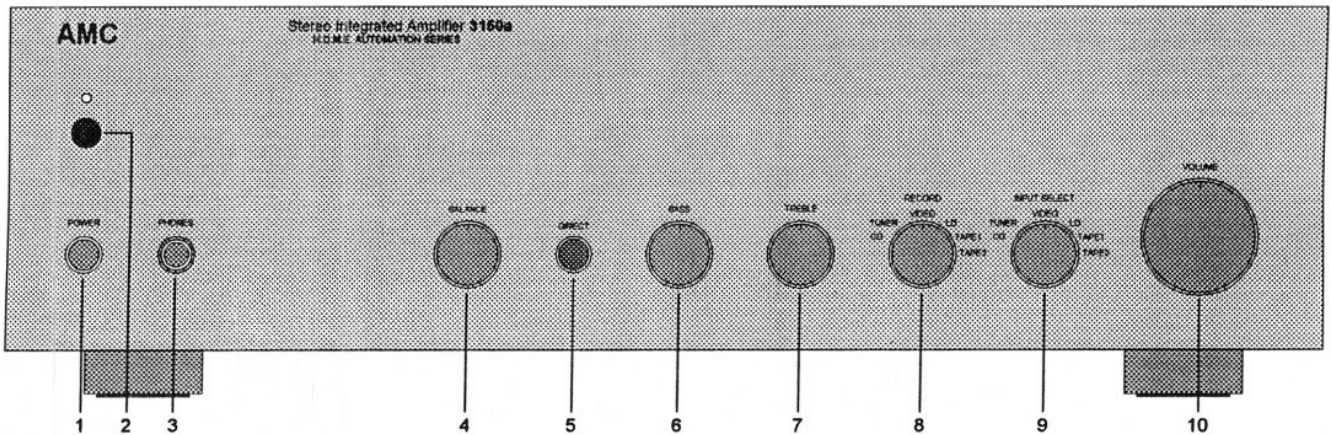

1. POWER SWITCH
2. INFRARED RECEIVER
3. PHONES
4. BALANCE CONTROL
5. DIRECT SWITCH

6. BASS CONTROL
7. TREBLE CONTROL
8. RECORD SOURCE SELECTOR
9. INPUT SELECTOR
10. VOLUME CONTROL

AMPLIFIER ADJUSTMENT

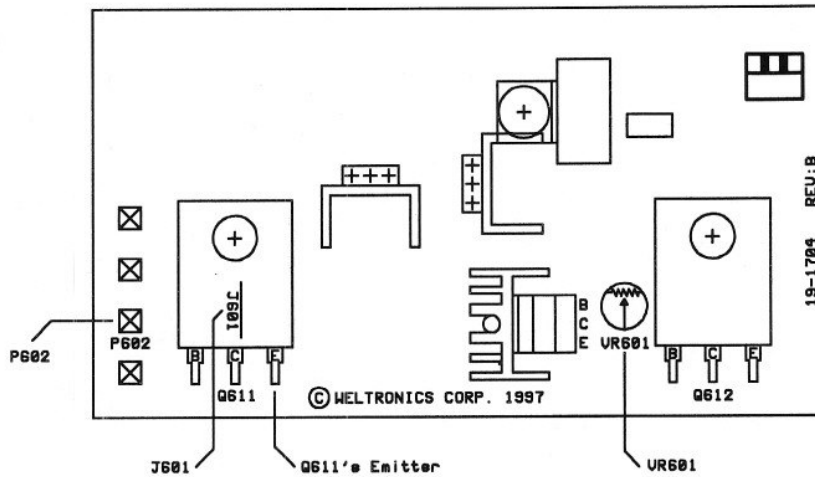

A. IDLE CURRENT ADJUSTMENT

1. Switch the unit off and disconnect the jumper J601.
2. Connect DMM across P602(B+) and Q611's Emitter, adjust VR601 for reading of $30 \pm 5\text{mV}$.
3. Repeat above procedures for each amplifier module.

B. FINAL ADJUSTMENT

1. Leave power on for minimum 5 minutes.
2. Repeat idle current adjustments.

SCHEMATIC DIAGRAM (INPUT)

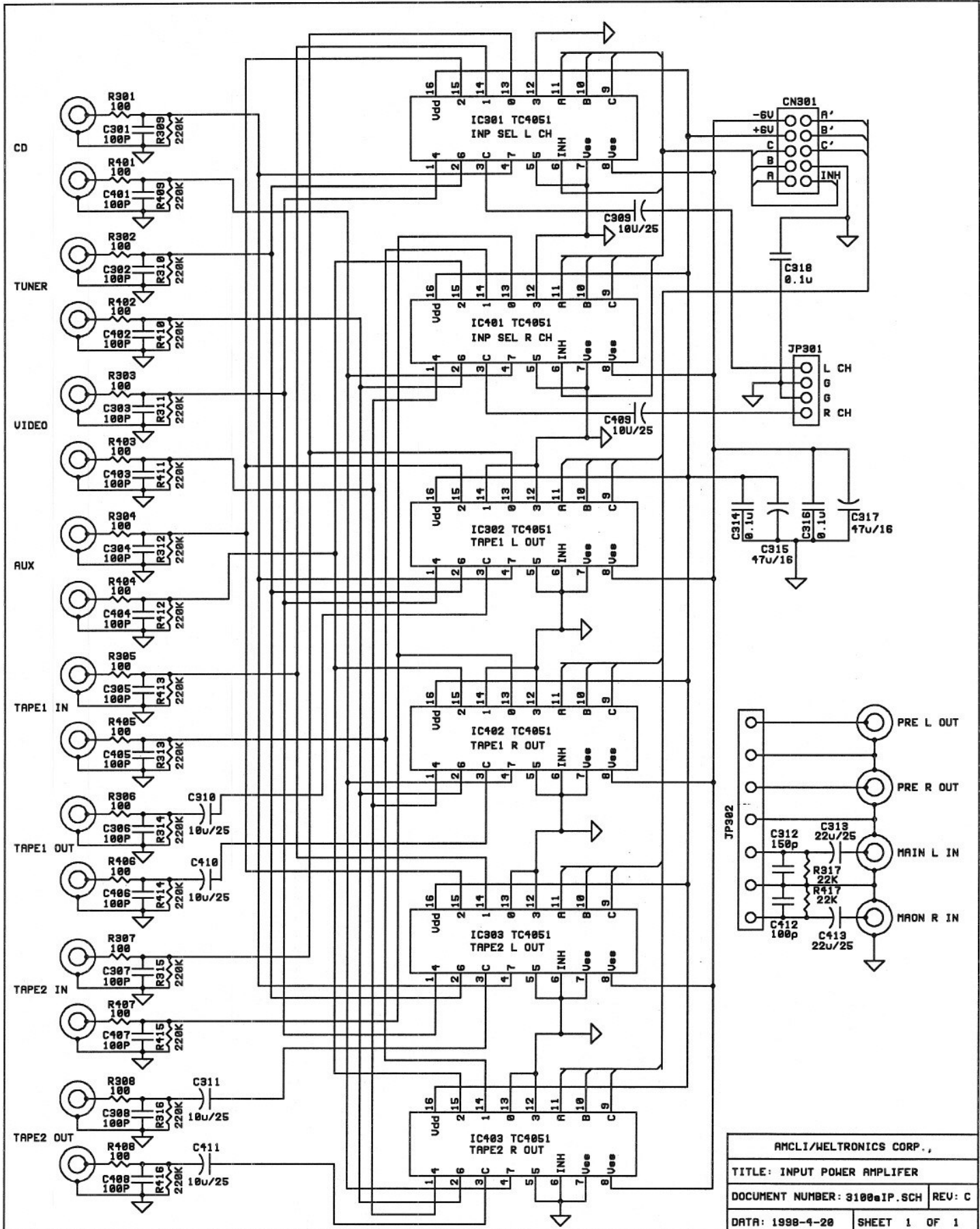

AMCLI/WELTRONICS CORP.,	
TITLE: INPUT POWER AMPLIFIER	
DOCUMENT NUMBER: 3100aIP.SCH	REV: C
DATA: 1998-4-20	SHEET 1 OF 1

SCHEMATIC DIAGRAM (TONE CONTROL)

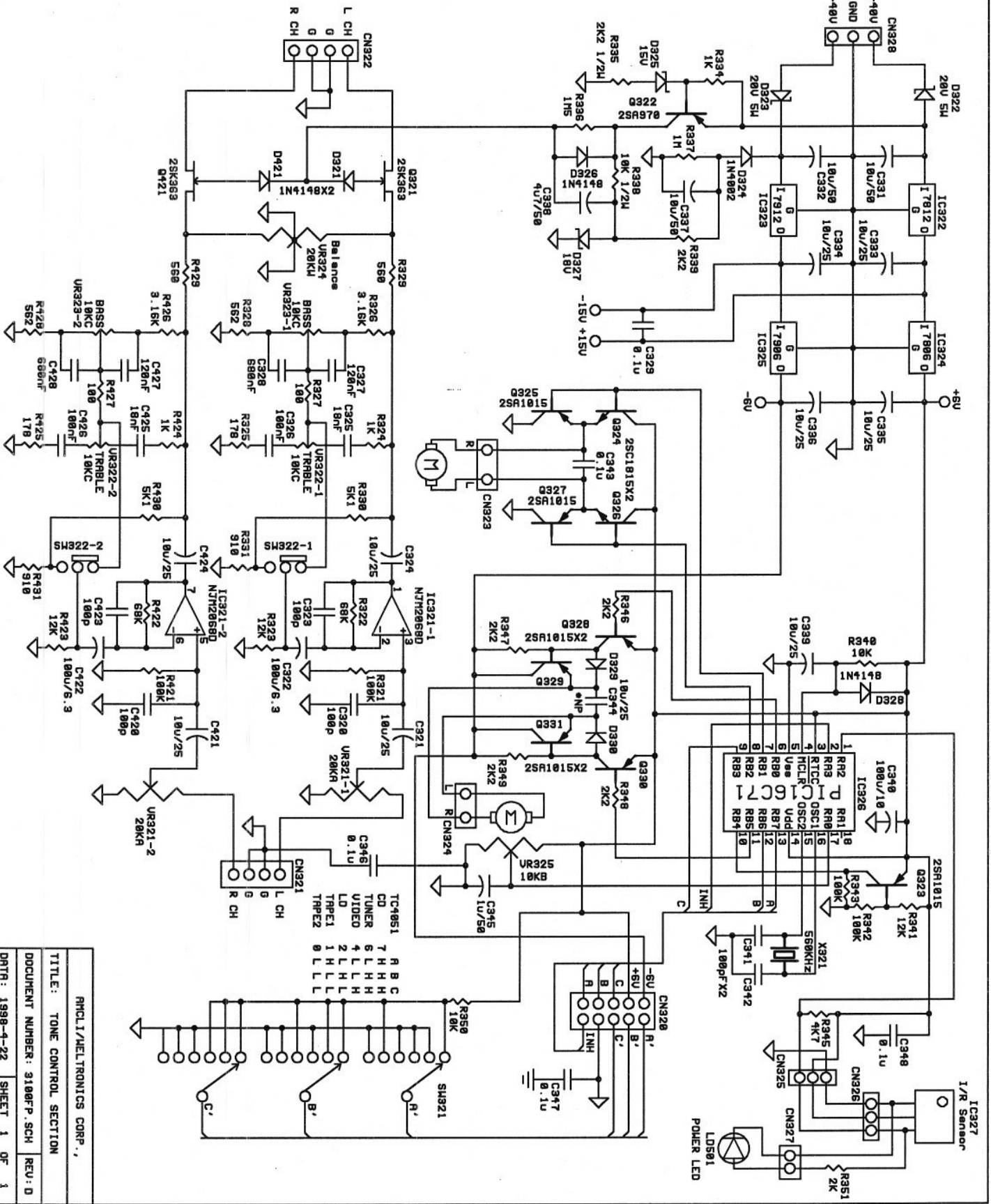

RMCL/ELTRONICS CORP.,
 TITLE: TONE CONTROL SECTION
 DOCUMENT NUMBER: 3100P.SCH REV: D
 DRT: 1998-4-22 SHEET 1 OF 3

SCHEMATIC DIAGRAM (AMPLIFIER & POWER SUPPLY)

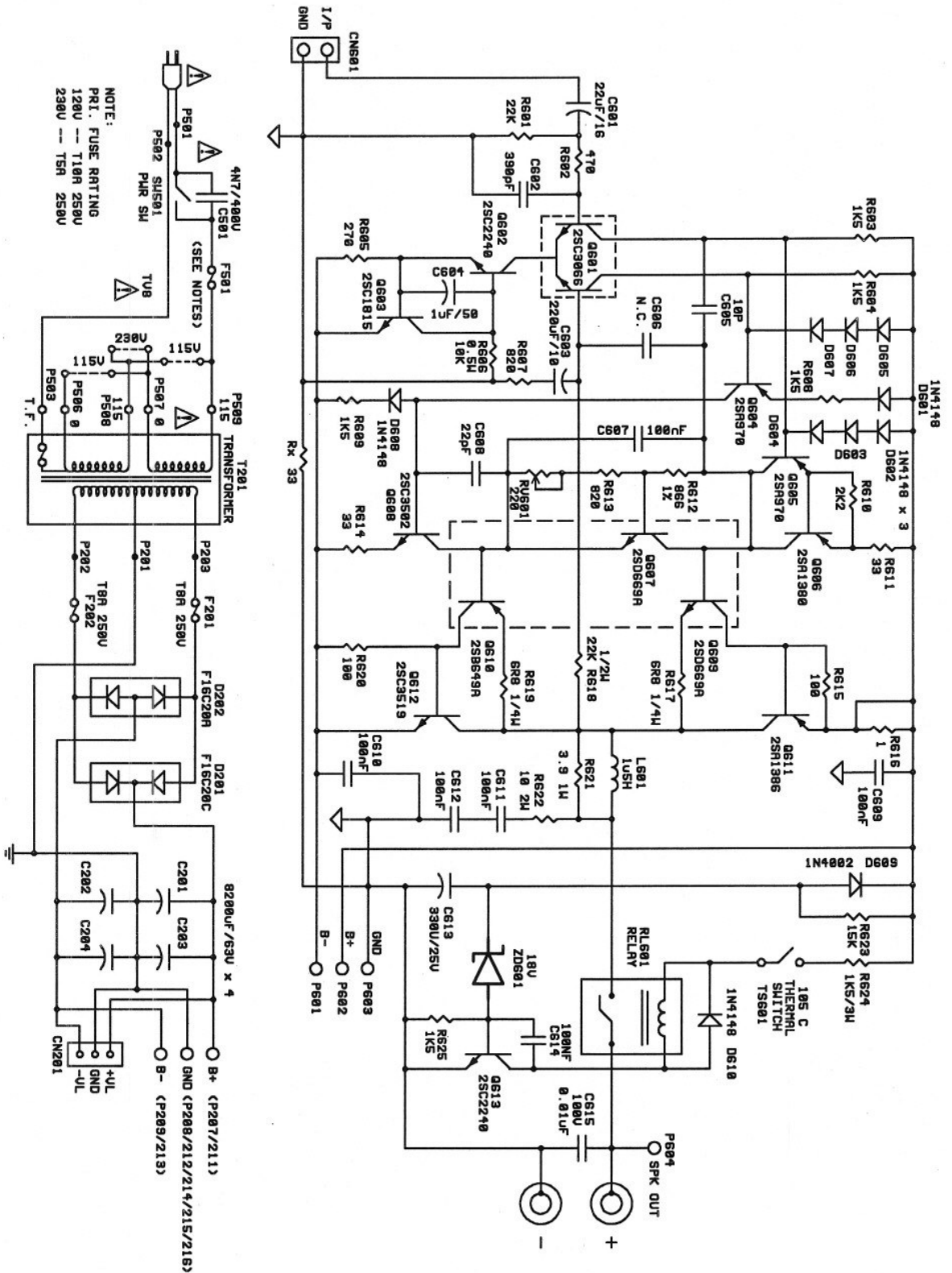

RHCL/ELTRONICS CORP.,	
TITLE:	AMP & PS SECTION
DOCUMENT NUMBER:	40283101.SG
REV:	F
DTR:	1998/4/20
SHEET	1 OF 1