



PHOTOFACT[®]

TRADE NAME Ampex Models 1250, 1260, 1270, 2012

SUPPLIER Ampex Audio Inc.,
1021 Kifer Road, Sunnyvale, Calif.

TYPE SET 2-Speed, 4-Track Monaural/Stereo Recorder

POWER SUPPLY 110 - 120 Volts AC, 60 Cycles

RATING Model 1260: 52 Watts, .48A @ 117VAC
Model 1270: 55 Watts, .52A @ 117VAC
Model 2012: 55 Watts, .54A @ 117VAC

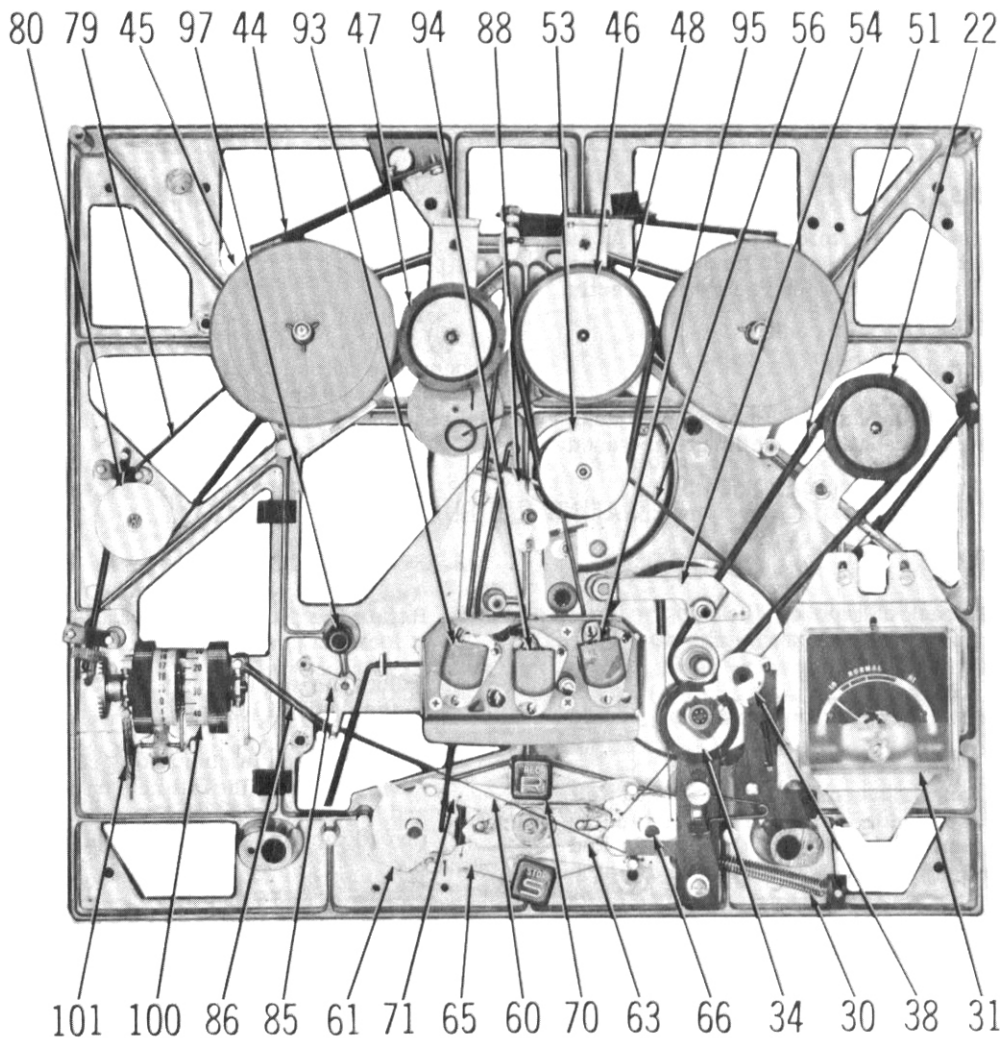
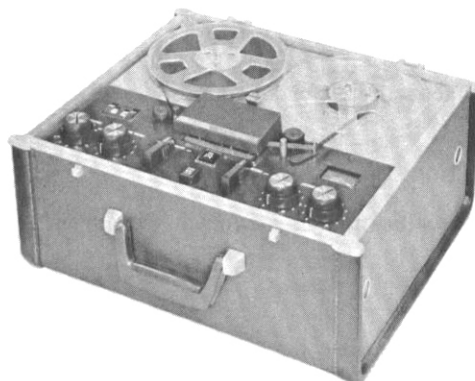

AMPEX MODELS 1250, 1260, 1270, 2012

HOWARD W. SAMS & CO., INC. Indianapolis 6, Indiana

FUNCTION OF CONTROLS

Play-Record Selector

Starts the transport in operation to record or play back a tape.

Fast Winding

Places the recorder in the rewind or fast forward mode.

Stop Button

Stops the tape movement in any mode when depressed.

Record Button

Places the transport in the record mode when depressed.

Speed Selection

Determines the tape speed; "In" for 3 3/4" ips and "Out" for 7 1/2" ips.

Off-Selector (Inner Knob)

Turns the power off in the "Off" position. Turns the power "On" in the Tape and Input position. Pro-

vides monitoring of the tape or the input when recording.

Mono-Stereo Selector (Outer Knob)

Selects channels to be recorded and played back.

Listening Volume

Determines the playback volume for the left channel (inner knob) and right channel (outer knob).

Radio Phono Recording Volume

Determines the recording level for the left channel (inner knob) and right channel (outer knob) when radio/ phono inputs are used.

Microphone Recording Volume

Determines the recording level for the left channel (inner knob) and right channel (outer knob) when the microphone inputs are used.

Tape Position Indicator

Shows the location of prerecorded material on a tape.

INPUT AND OUTPUT JACKS

Microphone Inputs

Left and right channel microphone input jacks (located on the right side of Model 1260 and on the rear panel on Model 1270) are used when recording directly from a microphone.

Radio Phono Input Jacks

Left and right channel Radio/ Phono Input jacks are located on the rear panel. These inputs are used

when making recordings from a tuner, radio TV receiver or phonograph.

Output Jacks

Left and right channel output jacks are provided on Models 1260 and 1270. These jacks are used to connect the output of the recorder preamplifiers to an external power amplifier. These jacks are located on the rear panel on Models 1260 and 1270.

OPERATING INSTRUCTIONS

Threading the Tape

1. Place a full reel of tape on the supply (left) spindle and an empty reel on the take-up (right) spindle.
2. Unreel about 24 inches of tape from the supply reel.
3. Thread the tape between the tape holdback felt (12) and the tape guide (97). Thread the tape on through the head slot, between the capstan and pressure roller (9) and below the automatic stop arm (10).
4. Insert the loose end of the tape into one of the slots in the reel hub of the take-up reel. Rotate the reel several times to take up the slack and secure the tape.

2. Rotate the Off-Selector to the Tape position.
3. Rotate the Play-Record control clockwise until it locks in position.
4. Adjust the left and right channel Volume controls to the desired listening level.
5. When the tape is completely played, remove the reels and place the full reel on the supply spindle and the empty reel on the take-up spindle. Re-thread the tape and continue playing the recording.

To Make a 4 -Track Stereophonic Recording

To Play a 4 -Track Stereophonic Recording

1. Thread the tape.

1. Thread a reel of tape on the transport.
2. Rotate the Off Selector to the Tape position.
3. Insert the microphone plugs into the left channel and right channel Microphone jacks. If the recording is being made from a tuner or phono-

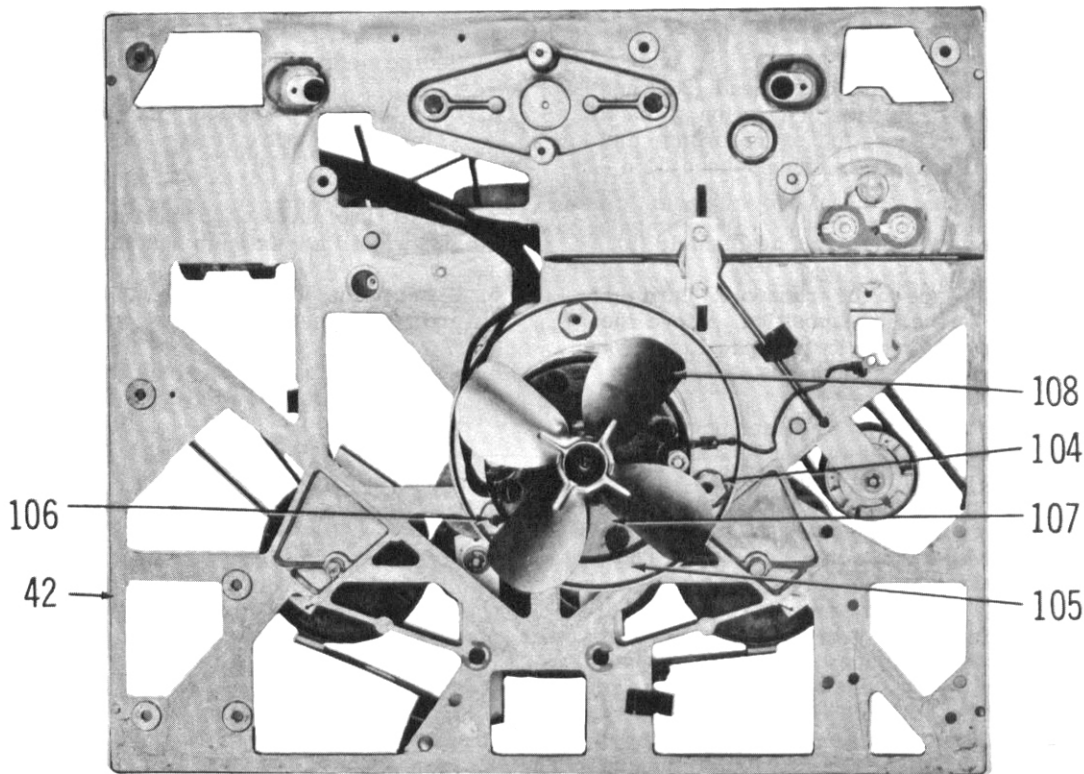

graph, plug the connecting cable plugs into the left channel and right channel Input jacks.

4. Place the Mono-Stereo selector in the Stereo-Left Channel position. To preset the recording level, speak into the microphone and increase the left Channel Microphone recording level until the proper recording level is obtained. Repeat this procedure for the right channel recording level.

NOTE: If a sound source other than microphones is used, use the Radio/Phono recording level controls.

5. With the recording levels properly set, depress the Record button and rotate the Record-Play control clockwise to begin the recording.
6. To monitor the tape while the recording is being made, adjust the Listening Volume controls until the desired listening level is obtained. To monitor the input, rotate the Off-Selector control to the Input position.

NOTE: When recording with microphone, keep the listening volume low and keep as much distance as possible between the recorder and microphones to prevent feedback.

7. To stop tape motion, depress the Stop button. When the end of the tape passes the head, the transport will automatically stop. Remove the reels and place the full reel on the supply spindle and the empty reel on the take-up spindle. Rethread the tape and continue recording.

To Play a Monaural Tape

1. Thread the tape.
2. Rotate the Off-Selector control to the Tape position. Rotate the Mono-Stereo switch to the Mono 1 or Mono 2 position, depending on the track being played.
3. Select the proper tape speed.
4. Rotate the Record-Play control clockwise. Adjust the left channel or right channel Listening Volume control to the desired listening level.

To Rewind the Tape

To rewind the tape, rotate the Fast Winding control counterclockwise until it locks in position. The tape will be wound from the take-up reel to the supply reel at a fast rate of speed. The tape movement can be stopped at any time by depressing the Stop button.

To Fast Wind the Tape in the Forward Direction

Rotate the Fast Winding control clockwise until it locks in position. The tape will move from the supply reel to the take-up reel at a fast rate of speed. Tape movement can be stopped at any time by depressing the Stop button.

To Erase a Tape

If it is desirable to erase a tape without recording new material on the tape, follow the normal recording procedure, however, turn all recording level controls to minimum.

ADJUSTMENTS

Head Height

The record head (94), playback head (95), and erase head (93), must be on line in relation to each other to insure proper operation of recording and playback. The following steps give proper head alignment.

1. Remove the head cover (4), and head shield (5).
2. Thread a reel of tape on the transport. Turn the power switch to the Tape position. Move the Play-Record selector clockwise and allow several feet of tape to pass the heads.
3. Depress the Stop button. The tape now should be level between the felt tape holdback washer (12), pressure roller (9), and capstan. If the tape bows up or down between these points, adjust the tape guide (96) height by turning the screw on top of the guide until the tape travels in a smooth, straight line.
4. Check the top head pole piece of each head. The top edge of each pole piece of each head should be on line with the top edge of the tape.
5. To adjust the head height, turn the front and rear head bracket screws. The front surface of each head must be vertical to insure good contact with the entire width of the tape as it passes each head. Recheck each adjustment made, to see that these requirements are met.

Head Azimuth

Erase Head

The erase head gap must be perpendicular to the line of tape travel. Make necessary adjustment by turning the azimuth adjustment screw. After adjusting azimuth, recheck height adjustment.

Record Head

1. Thread a blank tape on the transport.
2. Connect an audio generator to the left channel Radio/Phono input. Set the audio generator to 10 kc.
3. Turn the Off Selector to the Tape position and the Mono-Stereo Selector to the Mono-1 position.
4. Connect an AC-VTVM to the left channel output jack. Depress the Record button and turn the Record-Play control clockwise.
5. Increase the left channel Radio/Phono record level control and the audio generator output level until the VTVM shows an indication. Meter should be set on the 1-volt scale.
6. Adjust the record head azimuth adjustment screw for maximum deflection on the VTVM.

Playback Head

1. Thread a standard alignment tape on the transport.

2. Connect an AC-VTVM to the left channel output. Set the meter range selector on the 1-volt range.
3. Start the tape in motion. Increase the playback Volume to obtain a half-scale reading on the VTVM.
4. Adjust the playback head azimuth adjustment screw until a maximum reading is obtained.
5. Connect the VTVM to the right channel output and repeat the adjustment.
6. Final azimuth adjustment will be for an average reading between the left and right channel outputs.

Take-up Torque

1. Place an empty reel with a 2-inch hub on the take-up spindle.
2. Connect a 30-inch length of string to the hub and rotate the reel to take up the string.
3. Connect a 0-8 oz. spring scale to the free end of the string.
4. Hold the automatic stop arm in the operating position.
5. Turn the Play-Record Selector to the Play-Record position.
6. The reading on the scale should be 2.3 to 3 oz. in.
7. If adjustment is necessary, rotate the play take-up spring (25) clockwise (looking from bottom side) to increase torque, or counterclockwise to decrease the torque.

Fastwind Holdback Tension

1. Connect the spring scale to the fastwind holdback tension spring on each reel hub.
2. Tension should be 0.6 to 0.9 oz. in.
3. Turn the adjustment screws to obtain this reading.

Pressure Roller Tension

1. Turn the power off and rotate the Play-Record Selector to the Play-Record position.
2. Connect a 0 to 5 lb. spring scale to the end hole in the pressure roller arm.
3. A reading of 2.2 to 3 lbs. should be obtained when the pressure roller just moves away from the capstan surface.
4. Adjustment is made by turning the pressure roller tension spring (55) in or out of arm (54).

CLEANING

To insure maximum efficiency from the recorder, it is necessary that various parts be kept clean. As the unit is operated, a tape oxide coating collects on the head surfaces, tape guides, capstan, and pressure roller. Clean the head surfaces with a soft cloth dampened with a commercial head cleaner. The pressure roller, capstan, and tape guides may be

cleaned with alcohol.

When the top plate is removed to service the transport, clean accumulated dust and foreign material from the transport. Using a cloth dampened with alcohol, clean the driving surfaces of all pulleys and spindles.

TROUBLE CHART

Symptom	Cause	Remedy
Capstan does not rotate when unit is turned on.	<ol style="list-style-type: none"> 1. Capstan-flywheel belt (56) broken. 2. Defective motor (107). 3. Speed change assembly jammed. 	<ol style="list-style-type: none"> 1. Replace capstan - flywheel belt (56). 2. Replace motor (107). 3. Move speed change control to the other position.
Tape counter does not function.	<ol style="list-style-type: none"> 1. Tape counter belt(79)off pulleys or broken. 2. Tape counter mechanism dirty. 	<ol style="list-style-type: none"> 1. Place belt (79)back on pulleys or replace the belt (79) if broken. 2. Clean mechanism and lubricate.
Both tape counter scales rotate at same speed.	<ol style="list-style-type: none"> 1. Tape counter latch spring (101) broken or disconnected. 	<ol style="list-style-type: none"> 1. Connect or replace spring.
Does not operate in rewind mode.	<ol style="list-style-type: none"> 1. Fastwind belt (48) broken. 2. Rewind idler (47) worn. 3. Scissor arm spring (64) broken. 	<ol style="list-style-type: none"> 1. Replace fastwind belt (48). 2. Replace rewind idler (47). 3. Replace spring (64).
Does not operate in fast-forward mode.	<ol style="list-style-type: none"> 1. Fastwind belt (48) broken. 2. Scissor return spring (64) broken. 	<ol style="list-style-type: none"> 1. Replace fastwind belt (48). 2. Replace spring (64).
No takeup in Play-Record mode.	<ol style="list-style-type: none"> 1. Take-up belt (51) broken. 2. Incorrect take-up tension. 3. Take-up pulley spring (27) broken or disconnected. 	<ol style="list-style-type: none"> 1. Replace take-up belt (51). 2. Make adjustment as described under "Adjustment". 3. Connect or replace take-up pulley spring (27).
Tape spills when Stop button is depressed.	<ol style="list-style-type: none"> 1. Brake pads worn. 2. Brake arm spring (78) or (77) broken. 	<ol style="list-style-type: none"> 1. Replace brake pads. 2. Replace spring (78) or (77).
Wow or Flutter.	<ol style="list-style-type: none"> 1. Dirt on components in tape threading path. 2. Flat spot on the pressure roller (9). 3. Worn or oily capstan drive belt (56). 	<ol style="list-style-type: none"> 1. Clean these components thoroughly. 2. Replace the pressure roller (9). 3. Clean or replace capstan drive belt (56).
Abnormal tape speed.	<ol style="list-style-type: none"> 1. Low line voltage. 2. Incorrect pressure roller tension. 3. Defective drive motor (107). 4. Excessive tape holdback tension. 	<ol style="list-style-type: none"> 1. Check for proper line voltage. 2. Check pressure roller tension. 3. Replace drive motor (107). 4. Check tape tension.
Poor record or playback.	<ol style="list-style-type: none"> 1. Worn or dirty erase (93), record (94), or playback head (95). 2. Defective component in amplifier circuitry. 	<ol style="list-style-type: none"> 1. Check condition of heads and replace if necessary. 2. Check voltage and resistance per schematic. Replace defective components.

A PHOTOFACT "EXPLODED" VIEW
 ©Howard W. Sams & Co., Inc. 1963

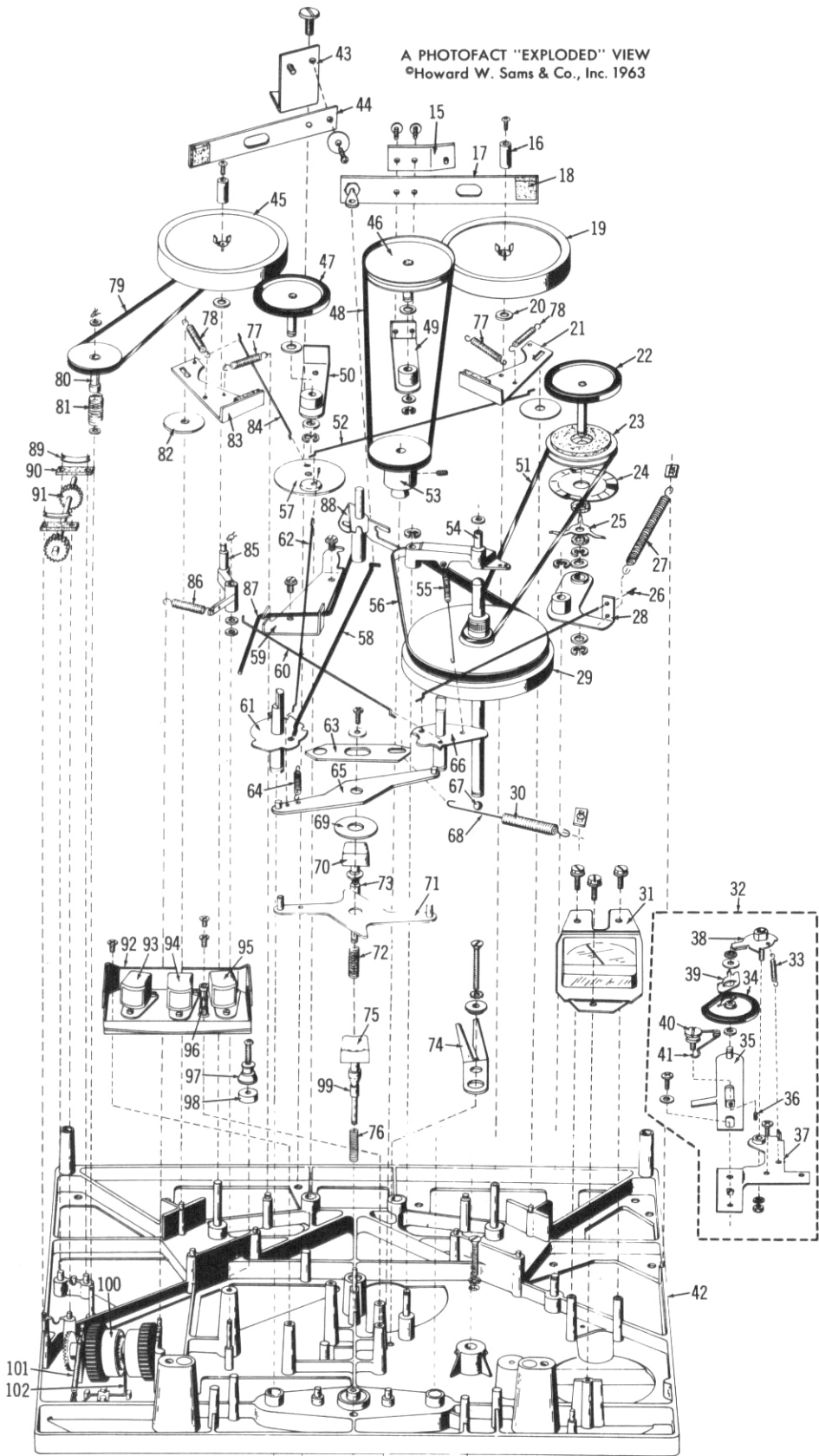

A PHOTOFAC "EXPLODED" VIEW
©Howard W. Sams & Co., Inc. 1963

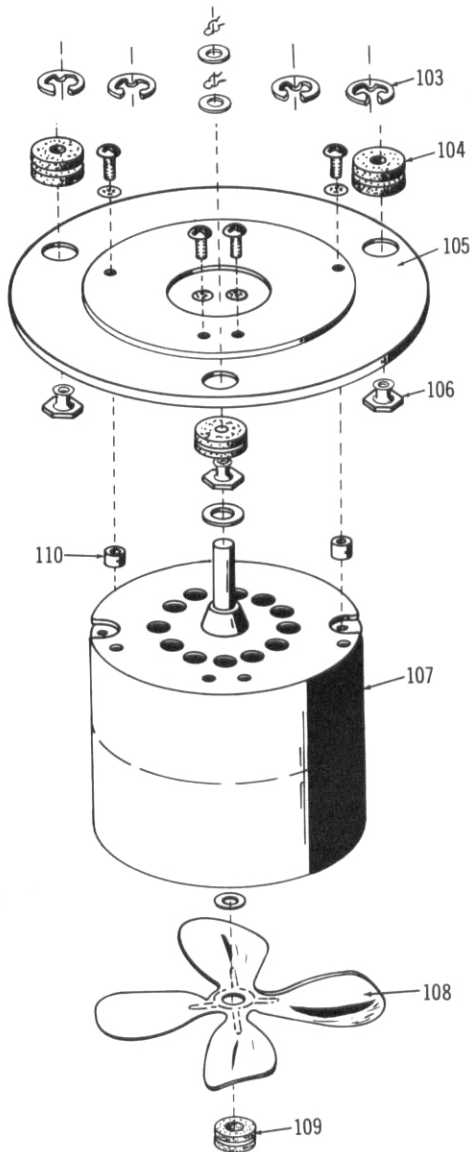
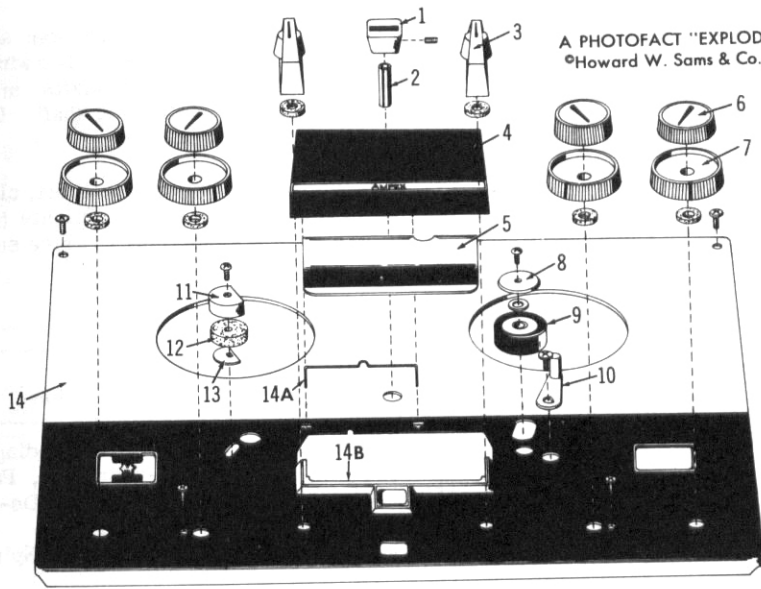

LUBRICATION

Lubrication is necessary to eliminate slow operation and undue wear. Using a good grade of medium heavy, nonhardening grease, lubricate all sliding surfaces in the mode selector cam assembly, capstan thrust bearing, tape counter shaft bearings and gears, speed change yoke assembly plunger, and speed change detent bracket.

Clean all pulley shafts and bearings and lubricate the shafts with a thin coating of a good grade of

oil. Clean and lubricate the capstan shaft and bearing, pressure roller bearing, fastwind pulleys and shafts, spindle bearings and shafts, motor bearings, and take-up pulley bearing and shaft. Clean and lubricate all pivots with light oil.

After lubricating the transport, clean all excess lubricant from the parts to eliminate the possibility of the lubricant transferring to drive surfaces.

MECHANICAL PARTS LIST

Ref. No.	Part No.	Description	Ref. No.	Part No.	Description
1	10-0123-02	Knob, Speed Change	48	31-0001-1	Belt, Fast Winding
2	20-0053	Bushing	49		Pulley Bracket, Part of 46
3	10-0053	Knob, Fastwind and Play-Record	50	27-0011	Spring, Brake De-energizing
4	04-0309-1	Cover Assembly, Head	51	31-0002	Belt, Take-up
5	04-0021-2	Head Cover, Mu-Metal	52	23-0113-1	Link, Take-up Spindle Brake
6	10-0054-2	Knob, Control, Upper	53	04-0322-1	Motor Pulley
7	10-0024-2	Knob, Control, Lower	54	04-0025	Arm Ass'y, Pressure Roller
8	29-0032-4	Cover, Pressure Roller, Dark Grey	55	27-0109	Spring, Pressure Roller Tension
9	04-0020-1	Pressure Roller	56	31-0015-1	Belt, Capstan Drive
10	04-0057-5	Arm Assembly, Automatic Stop	57	03-0071	Lever Assembly, Brake Link
11	29-0034-1	Cover, Tape Holdback	58	21-0023-1	Control Rod, Fast Winding
12	44-0026-2	Washer, Felt Tape Holdback	59	26-0012-1	Bracket, Detent
13	33-0004-1	Base, Tape Holdback	60	21-0133	Rod, Tape Holdback Control
14	04-0317	Cover, Transport	61	04-0027-1	Cam Assembly, Fast Wind
14A	27-0110	Spring, Cover Assembly	62	23-0114	Link, Master Brake
14B	11-0099	Escutcheon	63	23-0016-1	Shuttle, Interlock
15		Plate, Holdback Tension Adjustment	64	27-0105	Spring, Scissor Return
16	21-0019-1	Cap, Turntable Shaft	65	04-0032-1	Arm Assembly, Upper Cam Control
17		Brake, Fastwind, Right	66	04-0028-1	Cam Assembly, Play Control
18		Pad, Brake	67	20-0007	Ball Bearing
19	04-0026-6	Turntable Assembly	68	27-0010-1	Spring, Shuttle Return
20		Washer	69	44-0024-3	Washer
21	04-0030-1	Brake Arm Ass'y, Take-up	70	03-0100-08	Pushbutton, Record
22	04-0313	Clutch Assembly, Take-up	71	04-0031-1	Arm Ass'y., Lower Cam Control
23		Pulley, Idler, Part of 22	72	27-0012-1	Spring, Shaft Return
24		Plate, Clutch Adjustment, Part of 22	73	23-0111	Shaft, Record
25		Spring, Clutch, Part of 22	74	22-0179	Guide, Belt
26	21-0132	Rod, Play Take-up Control	75	03-0100-07	Pushbutton, Stop
27	27-0013-1	Spring, Take-up	76	27-0012-1	Spring, Shaft Return
28		Arm, Take-up, Part of 22	77	27-0011	Spring, Brake De-energizing
29	04-0316	Capstan Assembly	78	27-0104	Spring, Brake Arm
30	27-0108	Spring, Shuttle Return	79	31-0003	Drive Belt, Tape Counter
31	14-0010	Meter	80	04-0023	Worm Pulley Assembly
32	02-0141	Automatic Stop Assembly	81	24-0003	Spring, Worm Counter Drive
33		Spring, Part of 32	82		Washer
34		Automatic Stop Cam, Part of 32	83	04-0029-1	Brake Arm Assembly
35		Automatic Stop Slide, Part of 32	84	23-0113-2	Link, Supply Spindle Brake
36		Screw, Set, Part of 32	85	23-0019-1	Arm, Holdback
37		Bracket, Automatic Stop, Part of 32	86	27-0011-1	Spring, Holdback Tension
38		Cam, Automatic Stop Actuating, Part of 32	87	23-0021-1	Wire, Dual Speed Detent and Equalization
39		Actuator, Automatic Stop, Part of 32	88	04-0323-1	Yoke Assembly (60 cycles)
40		Screw, Guide, Part of 32		04-0323-2	Yoke Assembly (50 cycles)
41		Spring, Slide Return, Part of 32	89	27-0004-1	Spring, Retainer
42	04-0034-1	Base Plate Sub-Assembly	90	13-0016-1	Pad, Retainer
43	03-0072	Bracket, Payoff Brake	91	03-0001-1	Jack Shaft Ass'y., Counter Drive
44		Brake, Payoff, Part of 43	92		Shield, Head Assembly, Lower
45	04-0026-6	Turntable Assembly	93	04-0323	Head, Quarter Track, Erase
46	03-0069	Pulley Assembly, Fast Wind	94	04-0324	Head, Quarter Track, Record
47	03-0070	Idler Assembly, Rewind	95	04-0325	Head, Quarter Track, Playback
			96	20-0052	Sleeve, Tape Guide
			97	21-0004	Tape Guide

MECHANICAL PARTS LIST (CONT'D.)

Ref. No.	Part No.	Description	Ref. No.	Part No.	Description
98	22-0086	Spacer, Tape Guide	105	33-0005-1	Mounting Plate, Motor Ass'y.
99	23-0112	Shaft, Stop	106	42-0026-1	Sleeve, Nut
100	02-0046-6	Tape Counter Assembly	107	59-0001	Drive Motor, With Pulley
101	27-0003-1	Spring, Tape Counter Latch	108	25-0003	Fan, Motor
102	23-0002-1	Latch, Escapement	109		Washer, Fan Mounting
103	32-0008	Ring, Retainer	110	44-0119	Spacer, Motor Mounting
104	13-0017	Shockmount, Motor			