

**MAINTENANCE PROCEDURE HANDBOOK**

**900 SERIES TAPE RECORDER**

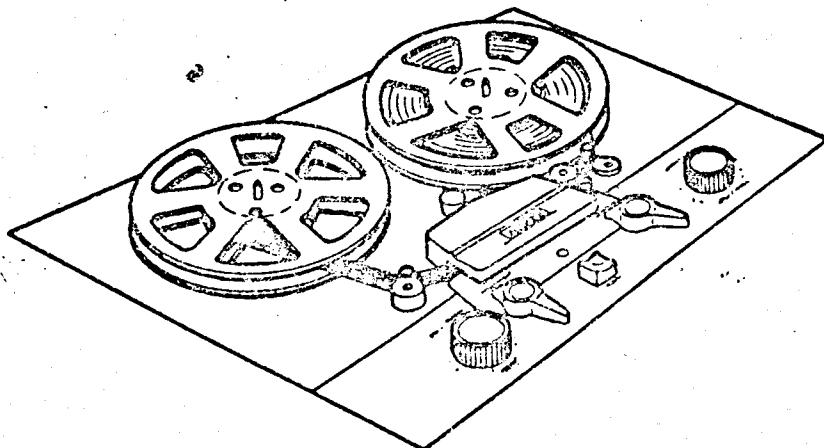
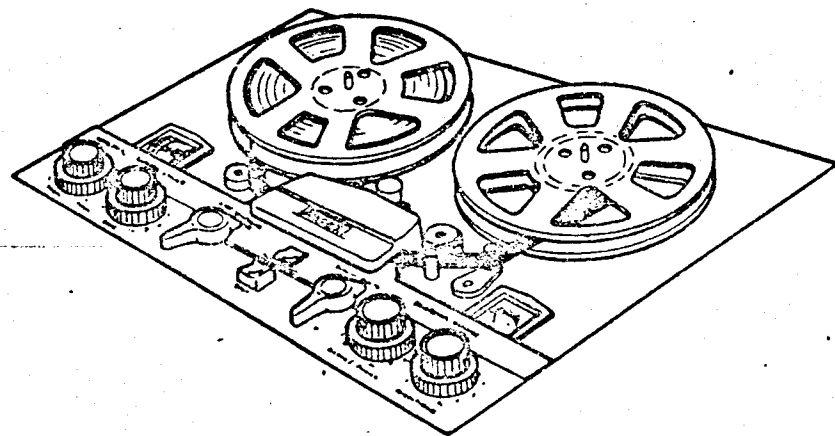

## INDEX -- TAPE DECKS

### 900 SERIES

I. MODEL DESCRIPTION--OUTSTANDING FEATURES .....	TD-I-1
II. THEORY OF MECHANICAL OPERATION .....	TD-II-1
III. ROUTINE MAINTENANCE	
1. HEAD CLEANING .....	TD-III-1
2. HEAD DEMAGNETIZATION .....	TD-III-1
3. LUBRICATION .....	TD-III-1
IV. MECHANICAL OPERATION CHECKOUT	
1. MODE OPERATION TESTS .....	TD-IV-1
2. MOTOR STALL TEST .....	TD-IV-2
3. TORQUE MEASUREMENTS .....	TD-IV-2
V. ELECTRICAL CHECKOUT PROCEDURE	
1. VISUAL HEAD ADJUSTMENT .....	TD-V-1
2. PLAYBACK PERFORMANCE .....	TD-V-2
3. RECORD PERFORMANCE .....	TD-V-3
4. ERASE PERFORMANCE .....	TD-V-5
5. FLUTTER AND WOW CHECK .....	TD-V-5
VI. SCHEMATICS	
1. 900 SERIES, MONAURAL RECORD .....	TD-VI-1
2. 950 SERIES, STEREO RECORD .....	TD-VI-2
VII. PARTS LIST (WITH EXPLODED VIEWS)	
1. MECHANICAL ABOVE TOPPLATE .....	TD-VII-1
2. MECHANICAL - BASE PLATE TO TOPPLATE .....	TD-VII-3
3. MECHANICAL - BELOW BASE PLATE .....	TD-VII-7
4. TUBE LAYOUT .....	TD-VII-9
5. UNDER CHASSIS LAYOUT .....	TD-VII-10
VIII. TROUBLE SHOOTING .....	TD-VIII-1

I. FEATURES OF VARIOUS AMPEX AUDIO TAPE DECKS  
(CONSUMER COMPONENT)

Model Number	"A" SERIES							900 SERIES					
	111	112	114	121 T & B	121 W & C	122	124	902	904	901	905	905	906
Mounting Portable		X				X				X			X
Table for Furniture	X			X	X								
Uncased			X			X		X	X		X	X	
Color Grey	X	X	X	X		X	X	X		X	X		X
Brown					X								
Beige									X			X	
Charcoal Grey (1960 Models)								X		X	X		X
Automatic Stop								X	X	X	X	X	X
Reproduce 1/2 track monaural	X	X	X	X	X	X	X	X	X	X	X	X	X
1/4 track monaural								X	X	X	X	X	X
Full track	X	X	X	X	X	X	X	X	X	X	X	X	X
2 track in-line stereo				X	X	X	X	X	X	X	X	X	X
4 track stereo								X	X	X	X	X	X
Recording 1/2 track monaural	X	X	X	X	X	X	X	X	X	X	X	X	X
2 track stereo											X	X	X
Can convert to 4 track stereo playback				X	X	X	X						

## II. THEORY OF MECHANICAL OPERATION

### GENERAL

The tape transport mechanism incorporates a single-speed induction motor and a system of mechanical linkages, pulleys, and belts to drive the capstan and the turntables. Three (3) modes of tape motion—PLAY or RECORD, FAST FORWARD, and FAST REWIND—are determined by two (2) controls on the front panel of the transport.

Tape motion in the play or record mode is controlled by the capstan idler pressing the tape against the capstan; tape speed being determined solely by the rotation of the capstan.

In the discussion that follows, the numbers in parenthesis refer to the reference number for the part as indicated in Fig. II-1, and the mechanical blow-up pictures in the parts list section.

### STANDBY MODE

Power is applied to the drive motor (111) with its pulley (66) when the SELECTOR switch is turned from its OFF position. The capstan (68) immediately begins to rotate, being driven by a belt (67) between the drive motor pulley (66) and the capstan flywheel (68). Capstan speed is determined by the speed selector (10) and (59), which simply positions the drive belt at a point of small or large circumference on the drive motor pulley. A second belt (65) from the motor pulley drives a fast winding pulley (47), and a third belt (76) from the capstan flywheel drives the play takeup pulley (75); neither of these pulleys has any effect in the standby mode as neither is mechanically engaged.

With the capstan in motion, the tape will accelerate to full speed almost instantly when placed in the play or record mode. A fan mounted on the lower shaft of the drive motor provides forced draft cooling to all components whenever power is applied to the unit.

In the following discussion of brake and turntable actions, reference is made to the right hand turntable as the TAKEUP turntable, and to the left hand turntable as the REWIND turntable in all modes of operation.

### PLAY OR RECORD

When the PLAY or RECORD knob is rotated clockwise, the following mechanical actions occur in sequence:

1. The tape holdback felt (15) presses the tape against the tape guide (11), providing holdback tension for the tape.
2. The rubber tired takeup pulley (75) presses against the takeup turntable (43), and starts the turntable rotation.
3. The capstan idler (6) presses the tape against the capstan (68), moving the tape at the speed selected.
4. The rewind (22) and takeup (71) brakes are pulled from their respective turntables.

Thus, the tape is placed in motion across the head assemblies. Intimate contact of the tape to the head surface is maintained by the pull from the capstan and the holdback tension. Tape fed from the capstan is wound on the takeup reel.

When the stop button is pressed, the tape holdback, capstan idler, and takeup pulley are released and spring action returns them to their standby positions. At the same time, the self-energizing brakes of both rewind and takeup turntables are activated, and braking action is applied to the rewind turntables.

## FAST FORWARD

When the FAST WINDING knob is rotated clockwise, the following mechanical actions occur in sequence:

1. The fast winding brake (left arm of 47) engages the rewind turntable, providing holdback tension.
2. The fast wind pulley (47) moves toward the takeup turntable (43), its drive belt (65) engaging the turntable to rotate it in a counter-clockwise direction.
3. The normal rewind and takeup brakes are pulled from contact with their respective turntables.

Tape is thus pulled by the takeup reel from the rewind reel, with holdback tension supplied by the fast winding brake to the rewind turntable. When the STOP button is pressed, the fast winding pulley returns to its standby position, deactivating the fast winding brake. The normal brakes are activated and braking force is applied to the rewind turntable.

## FAST REWIND

When the FAST WINDING knob is rotated counterclockwise, the following mechanical actions occur in sequence:

1. The fast winding brake (right arm of 47) is applied to the takeup turntable, providing holdback tension.
2. The fast winding pulley (47) and belt (65) engage the fast wind idler pulley (46) which in turn engages the rewind turntables (43), causing it to rotate in a clockwise direction.
3. The normal rewind and takeup brakes are pulled from contact with their respective turntables.

Thus, tape is pulled by the rewind reel from the takeup reel, with holdback tension being supplied to the takeup reel by the fast winding brake. When the STOP button is pressed the fast winding pulley returns to its standby position, deactivating the fast winding brake. The normal brakes are activated and braking force is applied to the takeup turntable.

## BRAKE ACTION

Braking force is applied to the trailing turntable (turntable from which tape is being pulled) by the normal brakes after the STOP button is pressed. These are self-energizing, limiting, friction type brakes which gradually apply greater braking force as they are permitted to move with the rotation of their respective turntables. Brake movement is mechanically limited to prevent tape breakage which would occur if the stopping action were too sudden.

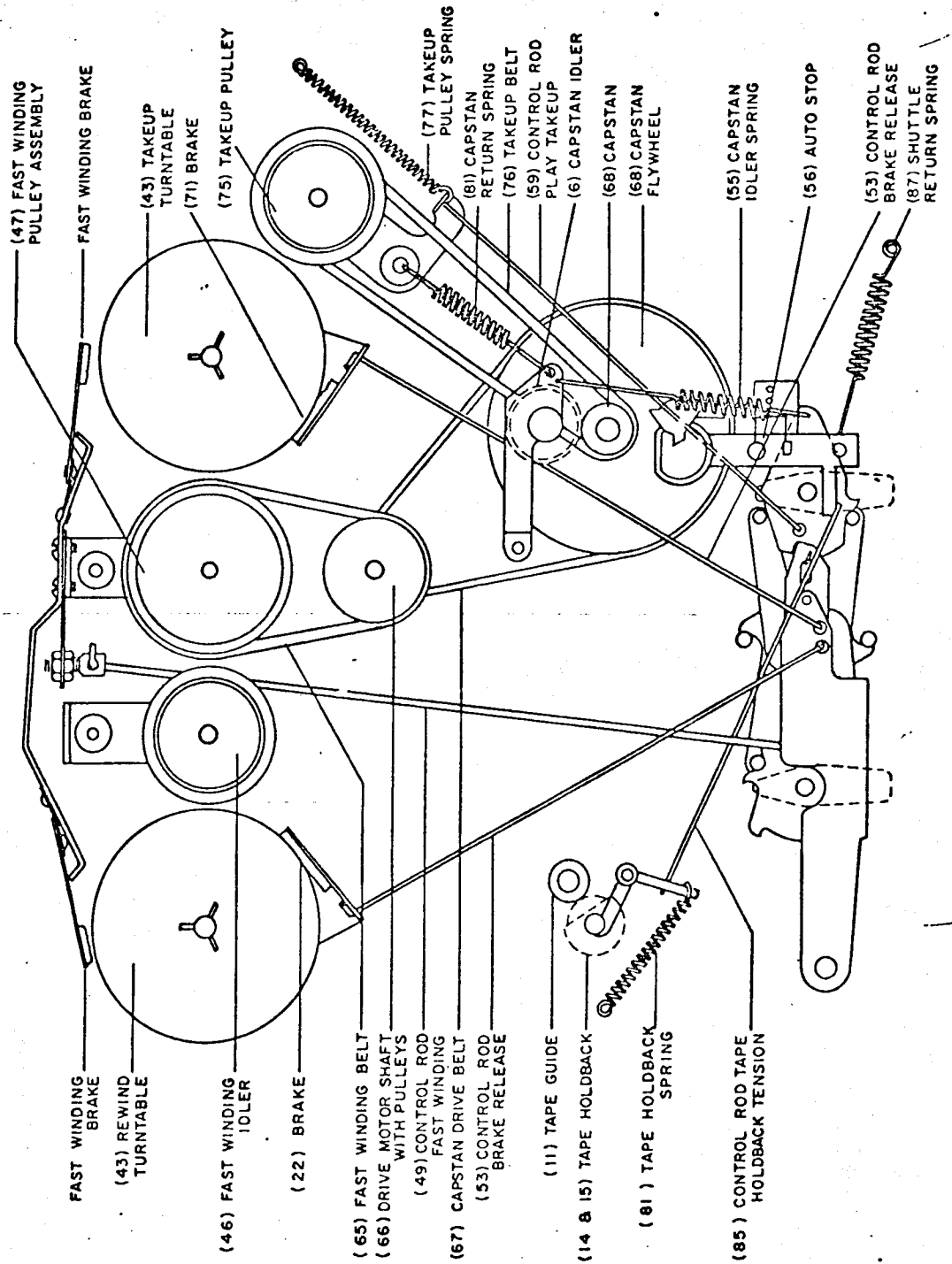

FIGURE VII-1. POSITION OF PARTS - STANDBY CONDITION

### III. ROUTINE MAINTENANCE

Routine maintenance procedures are described in the Owner's Reference Manual. These are functions which the user may easily perform to maintain his recorder in efficient operation. Since procedures are described in detail in the Owner's Reference Manual, they will be only generally outlined here.

#### III-1. HEAD CLEANING

Tape lubricant and oxide deposits may be cleaned off capstan, capstan idler, and guide post, using a good grade of denatured or isopropyl alcohol. Cleaning can be facilitated by using a cotton swab, such as a Q-Tip.

The tape holdback felt pad may be cleaned by lightly brushing area of tape contact to remove deposits. If area is quite worn in, pad may be rotated.

The heads are cleaned with a solution of Xylene and 0.1% Aerosal, (Ampex Catalog Part #823). Use with caution as it will affect the plastic used in the head cover, escutcheon, and knobs. Do NOT use other types of solvents as they may damage the material which binds the head laminations together.

#### III-2. HEAD DEMAGNETIZATION

Use Head Demagnetizer (Ampex Catalog Part #820) with tips covered to prevent scratching of head surface. Tips of demagnetizer should be run up and down straddling the gap of the head, and then SLOWLY withdrawn. Erase head need not be demagnetized.

Capstan and tape guides may become magnetized and should also be demagnetized occasionally.

#### III-3. LUBRICATION

In Ampex "A" Series and 900 Series recorders, two (2) different types of mechanical areas are lubricated. Sliding surfaces, where metal rubs against metal, require a medium heavy red grease, R.P.M. Aviation Grease #1, (Ampex Audio Part #71-0007), or high temperature silicone grease. This is used in the following areas:

1. All rubbing or sliding surfaces in the mode selector cam assembly.
2. Speed change detent at junction of spring linkage and detent bracket.
3. Speed change yoke assembly plunger.
4. Position indicator counter shaft—bearings and gears.
5. Capstan thrust bearing.

Pulley shafts and bearings should be disassembled and cleaned with alcohol. Residue formed by the gumming of previous lubricants can best be removed from the Oilite bearing using a stiff bristled brush and alcohol or kerosene. After cleaning, lubricate the shaft surface lightly with Alemite AO-I (Ampex Audio Part #71-0181).

The following assemblies to be treated as described above:

1. Capstan shaft (68) and bearing.
2. Capstan idler bearing (6).
3. Play takeup assembly (75)—lightly oil both sides of phenolic washer between large brass washer and retainer ring. Mount retainer ring with burr side out.
4. Drive motor bearings and shaft.
5. Both turntable bearings and shaft(43).
6. Fastwind pulley assembly (47).
7. Fastwind idler pulley assembly (46).

The following arm pivot points are also lubricated with Alemite AO-I:

1. Constant holdback tension arm pivot.
2. Rewind idler assembly pivot.
3. Fastwind idler assembly pivot.
4. Play takeup assembly arm pivot.
5. Capstan idler arm pivot.
6. Tape position indicator escapement pivot.

The shaft area inside the tape position indicator is lubricated with Dow Corning Silicone #200 (Ampex Part #71-0021).

Volume control bearings and sliding brake surfaces should NOT be lubricated under any circumstances.

Do NOT use an excessive amount of lubricant as this causes contamination and deterioration of many recorder parts and functions. Where parts are greased, only sufficient grease should be used to cover the rubbing surface. Where parts are oiled, only a light coating rubbed on with a cotton swab (Q-Tip) over the area of the shaft is required.

Care must be exercised to prevent any lubricant from coming in contact with any belts or felt clutch or brake surfaces.



#### IV. MECHANICAL OPERATION CHECKOUT PROCEDURE WITH TOP PLATE MOUNTED

**EQUIPMENT:** 0-8 oz. scale  
2" diameter hub reel for turntable tension checks

**SET UP:** Recorder connected to 117 volts AC power.  
Recorder power turned on for all checks unless otherwise specified.

##### IV-1. MODE OPERATION TESTS

The mechanical operation of the components of the tape transport is fixed within strict design specifications and there are no adjustments. However, a few simple checks, as described below, would quickly determine that the transport is operating properly, or that corrective maintenance is required. Refer to section on TROUBLE SHOOTING—MECHANICAL for aids in corrective maintenance, if observed operation does not agree with steps listed below.

##### PLAY MODE

Load with 1800 foot reel of tape on rewind turntable. Place slowly in play mode of operation and observe for the following sequence of operation:

1. Tape holdback pad presses tape against tape guide.
2. Takeup turntable begins to rotate, cocking automatic stop arm.
3. Capstan idler presses tape against capstan.
4. Locks in play mode position.

Stop, using STOP button. Capstan idler and tape holdback pad return to standby position, both reels cease turning.

Place again in play mode and observe tape travel. Tape should be quickly taken up by takeup reel with no loops thrown as tape is fed by capstan. Automatic stop arm is cocked into position as tape is taken up, and should remain in this position while tape is in motion across it.

##### SPEED CHANGE

Change speed several times with SPEED CHANGE BUTTON. Change in either direction should be accomplished easily and with no rubbing or mechanical noise following shift. Some overtravel of speed change button when shifting from 3 3/4 to 7 1/2 i.p.s. is proper. After shift, button should return to proper notch.

##### COUNTER OPERATION

Check that the hundredths (left) dial shifts one unit for each revolution of the units (right) dial. Change starts at approximately the 95 point of the units dial and ends as it reaches 0. This should be further checked in subsequent operation checks at various places on the hundredths dial to be sure either dial does not hang up and/or stop.

##### AUTOMATIC STOP

1. Check that there is no grinding noise from the automatic stop cam while the arm is being held in the cocked position by tape travel. There will be a slight buzz as the arm is cocked, but should cease after cocking.
2. Stall takeup reel. Automatic stop should stop mechanical operation and return recorder to standby condition. Listen to automatic stop to be sure automatic stop cam is not continually rotating. This will happen if automatic stop assembly is not properly positioned.
3. Fastwind for approximately full reel of tape on takeup turntable. Automatic stop

arm should not drop back far enough to operate stop action (a position approximately parallel to top edge of plastic escutcheon).

#### CAM OPERATION

Check by performing the following sequence of operation. Return to neutral with STOP button after each step, unless otherwise specified. Functions cease and recorder returns to standby after each stop.

1. From play mode to rewind without depressing STOP button.
2. From play mode to fast forward without depressing STOP button.
3. Using FASTWIND knob, shuttle between fast forward and rewind without locking in either mode.
4. Record mode: release with automatic stop by stalling takeup turntable.
5. Play mode: release with automatic stop by stalling takeup turntable.
6. Place in either fastwind mode. Stop with STOP button. Place in play mode. Should lock in play mode easily. Repeat several times. This checks return of cam shuttle assembly to neutral.

#### IV-2. MOTOR STALL TEST

Fastwind until nearly a full reel of tape on takeup turntable, approximately 100 feet on rewind turntable. Place in fast rewind. Motor must not stall. (Stall indicated by a drastic slowing down or stopping of capstan rotation.) Tape should be at normal rewind speed within a few seconds. Stop, and place in fast forward mode again, checking for motor stall. Repeat several times between fast rewind and forward.

Rewind until nearly a full reel of tape is on rewind turntable, and repeat steps above checking for motor stall.

Complete rewind and remove tape.

#### IV-3. TORQUE MEASUREMENTS

##### PLAY TAKEUP TORQUE

1. Place torque measuring reel on takeup turntable. The torque measuring reel is a standard reel with a hub diameter of 2 inches, and has wrapped on the hub a length of approximately 30 inches of string or mylar based tape. The free end has a loop for connecting to scale.
2. Takeup tension as read on scale indicator should be within 3.0 to 5.5 inch ounces with recorder in play mode. This reading is to be taken when the pull on the scale has reached that required to stall turntable during takeup of string. Check for smoothness of takeup of string.

##### PLAY HOLDBACK TENSION

1. Place torque measuring reel on rewind turntable. Thread tape between tape holdback felt and tape guide, but not across heads and through capstan area. Connect scale to end of tape.
2. Place in play mode. Pull tape slowly through tape guide and tape holdback felt. Be sure tape rides in proper location of tape guide. Holdback tension reading should be between 2.0 and 2.5 inch ounces.

This completes the mechanical checkout with top plate in place, and covers basic operation of the recorder. If malfunctions are indicated in above checkout, refer to section on TROUBLE SHOOTING—MECHANICAL. Further adjustments to components under top plate are listed in this section.

Fastwind holdback tensions are too low to be accurately measured with a 0 to 8 ounce scale. Takeup tensions in fastwind modes are not critical. Consequently, no tests are made for these tensions other than proper tape handling as observed in fastwind mode of operation.

## V. ELECTRONIC CHECKOUT PROCEDURE

### GENERAL

The electrical components of the Ampex tape recorder/reproducers are held to strict design requirements to insure maximum reliability in performance coupled with a minimum of adjustments throughout the lifetime of the recorder. The procedures listed below are written in a step by step progression for easy following. In order to insure quality performance within specifications, use of quality test equipment is mandatory with the following procedures. Deviations from specified limits indicate improper adjustments or need for checking for malfunctioning component using standard electronic trouble shooting procedures. For assistance, refer to section on TROUBLE SHOOTING—ELECTRONICS.

Prior to performing the electronic checks, demagnetize and clean the heads as described under ROUTINE MAINTENANCE.

### TEST EQUIPMENT

1. AC vacuum tube voltmeter capable of reading -50 dbm. (.002 volts rms).
2. Audio oscillator with constant and stable output from 50 cycles to 20,000 cycles.
3. Flutter meter.
4. Bias trap (shown in Figure V-1).
5. Standard alignment tape: Ampex Audio #5563 for 7 1/2 i.p.s. (Ampex Audio #6000 may be used for 3 3/4 i.p.s.; however, checkout at 7 1/2 i.p.s. is desirable).
6. Speaker amplifier system, for monitoring.
7. Necessary cables for interconnecting above equipment to recorder.
8. 270K resistor, for loading output of recorder.
9. Demagnetized screwdriver with fine blade for azimuth adjustments.
10. Oscilloscope may also be used, connected to input of AC VTVM.

### V-1. VISUAL HEAD ADJUSTMENTS

The working surface of each head must be parallel to the capstan. This can best be checked by first sighting across face of playback head and comparing with vertical edge of capstan. Adjustment can be made using either front or back head mounting screw. Record head can then be checked by comparing with playback head. Erase head can then be checked comparing with record head.

To check the vertical head height, load with the standard alignment tape. Place in play mode and 7 1/2 i.p.s. Check for equal number of laminations above and below record and erase heads (stereo record models). On monaural recorders, there should be approximately two (2) laminations above top edge of tape. Playback head height is adjusted in 4-track (UP) position so that the top of the tape is on the line between the Mu-metal and beryllium copper laminations of the top head track.

**NOTE:** Alignment tape should preferably be stored in reverse wrap as it would be at finish of playing through and not rewinding. This stores the tape in a good pack condition and reduces edge tape stretch, which may skew tape, due to irregular tape rewind. For use, place reel of alignment tape on takeup turntable and rewind to beginning tones and commentary.

The complete electronic checkout is divided into two (2) general categories. The first category covers the playback amplifiers section of the recorder. After this section is checked out and known to be within specifications, then the record amplifier and associated circuits are checked out as described in the second category. Since Ampex recorders utilize the three head stack arrangement, the playback amplifier can conveniently be used to checkout the record amplifier.

## V-2. PLAYBACK PERFORMANCE

### SET UP

Rewind to beginning of alignment tape. Set LISTENING LEVEL to approximately 9, SELECTOR to single, playback head shift level down. Connect AC VTVM to right channel output of recorder. Connect monitor speaker-amplifier system to output of VTVM, if provided. Output of recorder should be loaded with a 270K resistor. However, if meter does not have an output provision, the speaker-amplifier may be connected across the AC VTVM input. This would then provide partial, if not all, of the 270K loading required. (Loading satisfactory if input resistance of amplifier between 250K to 500K. If oscilloscope is used, connect across input to AC VTVM.)

### AZIMUTH ADJUSTMENT

Set VTVM to -10 dbm (.3 volts rms) scale. Put recorder in play mode. First tone on tape is 10 kc. for playback head azimuth adjustment. Adjust for maximum reading on meter using rear right screw of the three playback head mounting screws. (Remove Mu-metal cover for access. Replace after adjusting.)

### GAIN TEST

Second tone is 250 cycles recorded as normal maximum. Set VTVM to 0 dbm (1 volt rms) scale. Should have at least .75 volts rms output on each channel at maximum setting of listening control. Outputs of each channel should be within 2 db of each other. (NOTE: When connected as stated above, left channel output is read with SELECTOR in single position, right channel output is read with SELECTOR in stereo position.)

### LISTENING LEVEL CONTROL TRACKING

Again, using second tone, (250 cycles at normal maximum) reduce listening level control (s) until left channel output is reduced -15 db from maximum, or .135 volts rms. Right channel reading on models with dual concentric controls with pointers aligned must be within  $\pm 4$  db of left channel reading. On model with single ganged control, right channel reading to be  $\pm 2$  db of left channel.

### PLAYBACK FREQUENCY RESPONSE

Third tone is 250 cycles recorded at -10 db below normal maximum. Set VTVM to -10 dbm (.3 volts rms) scale. Adjust LISTENING LEVEL control (s) to a point somewhere around 8 or 9 for a convenient reference level output, preferably -12 db (.195 volts rms). With stereo record models, each channel can be independently set, pointers will not necessarily be exactly aligned for equal output. With monaural record models, set the control using the left channel; the right channel should be within 2 db from the left channel reading. Observe the difference between channels and account for it in subsequent response checks.

After LISTENING LEVEL control (s) is set, it should NOT be readjusted during the remainder of checkout, as playback and record performance are referenced to this setting. Reference level output must be noted for use in later checks.

The tones following the 250 cycle reference tone are recorded at the same reference level and are used for checking the playback frequency response. These tones are from 10kc to 50 cycles. Response on each channel must be uniform within  $\pm 2$  db from 10kc to 100 cycles, 50 cycle response +4 db to -2 db. If necessary, adjust playback head dampening controls for uniform high frequency response during the 10,000 cycle tone.

Continue to play tape through and store in this played through condition as previously described.

## PLAYBACK SIGNAL TO NOISE RATIO

With Mu-metal head shield and electronics chassis shield in place, noise readings on VTVM should be below the following levels:

For 7 1/2 i.p.s.	-48 dbm	(.0031 volts rms)
For 3 3/4 i.p.s.	-43 dbm	(.0055 volts rms)

It is very important to listen for any noise, such as resistor, tube microphonics, etc., which would be objectionable to you if a customer. Since this is an audio recorder, the actual sound is as important as the actual meter reading.

## V-3. RECORD PERFORMANCE

Results from different tapes will not necessarily be consistent because of tape characteristics which vary between brands and types of tape. These characteristics affect the optimum bias point, high frequency response, distortion, and saturation level in tape performance. Consequently, specifications may not be met using certain types of tape. Specifications given are using average quality tape most generally available. If the customer states a preference, record adjustments should be made using his preferred tape.

In the following steps, disregard those for the right channel if checking out a monaural record model.

### SET UP

Retain VTVM as connected for playback performance check. Connect audio oscillator to line input jacks. On stereo record models connect to proper channel (L or R), or to both channel inputs, using a cable with two (2) phono connectors connected in parallel. On monaural record models, connect audio oscillator to REC input.

A bias trap, as shown in Fig. V-1, may be necessary across the AC VTVM input to eliminate interference of the 100kc bias frequency picked up by the playback head during record. If used, insertion loss of trap must be considered in response and noise readings.

Thread blank tape on recorder. Set to 7 1/2 i.p.s. tape speed. Lower ring of SELECTOR on stereo record models set to stereo position, L for checking left channel input level, and R for checking right channel input level. LISTENING LEVEL must remain as set in playback performance. SELECTOR, (top knob on stereo record models) set to single for checking left channel output, and to stereo for checking right channel output. RADIO/PHONO and MICROPHONE level controls set to O unless otherwise stated.

RECORD mode for all following steps, unless otherwise stated.

### BIAS ADJUSTMENT

1. Set audio oscillator to 500 cycles and approximately .5 volts output.
2. Advance RADIO/PHONO level control (s) for a reading of approximately -2 db (.62 volts rms) on VTVM.
3. Adjust lower bias trimmer (C20) for maximum reading on VTVM for left channel, and upper bias trimmer (C29) for maximum reading on VTVM for right channel.

### RECORD HEAD AZIMUTH ADJUSTMENT (left channel only)

1. Set audio oscillator to frequency of 10kc.
2. Adjust RADIO/PHONO level controls for reading of -22 dbm (.062 volts rms).
3. Adjust record head azimuth screw (right rear of the three mounting

screws) for maximum reading on VTVM. Be sure you are peaking on major peak, there is a minor peak each side of the major peak.

#### NOISE BALANCE (left channel only)

1. Turn RADIO/PHONO level control (s) to minimum and audio oscillator to minimum output.
2. With maximum gain on amplifier-speaker monitor, adjust NOISE BALANCE control for minimum of background 'popping' or 'crackling' as heard from speaker.
3. Return amplifier-speaker to normal setting. (If NOISE BALANCE adjustment was far off nominal, the bias should be rechecked.)

#### RECORD METER CALIBRATION

1. Set audio oscillator for 500 cycles and approximately .5 volts rms output.
2. Adjust RADIO/PHONO level controls for output of 10 db above reference level used for playback frequency response check. If -12 db (.195 volts) was used for playback response reference level using Ampex Audio #5563 alignment tape, adjust RADIO/PHONO controls for an output of -2 db (.62) on VTVM.
3. Adjust METER CALIBRATION control until needle of record meter is at maximum normal, between NORMAL (black) and HIGH (grey) portions of scale. Adjust on left channel only.
4. Check output reading of right channel. (Stereo record models only). Adjust lower ring of RADIO/PHONO level control for maximum normal reading on record meter. Right channel output of recorder should be within 2 db of left channel output.
5. With RADIO/PHONO controls minimum, check meter reading on left channel, should indicate less than 1/8" above off reading.

#### RECORD AMPLIFIER SENSITIVITY

1. Turn RADIO/PHONO level controls to maximum; SELECTOR controls to read left channel.
2. Set audio oscillator to 500 cycles. Adjust audio oscillator output control for tape deck reading of -2 db (.62 volts rms).
3. Measure output of audio oscillator. Should read .15 volts rms or less.
4. Repeat for right channel.

#### OVERALL RECORD-PLAYBACK RESPONSE

1. With audio oscillator set to 500 cycles, adjust RADIO/PHONO level controls for reading of -22 db (.062 volts rms) on VTVM.
2. Sweep audio oscillator through audio frequency range. Output from each channel to be uniform within the following limits:

7 1/2 i.p.s.	+2 db	50 cycles to 10kc at 15kc
	-2 db	
	+0 db	
	-4 db	
3 3/4 i.p.s.	+2 db	50 cycles to 8kc at 10kc
	-2 db	
	+0 db	
	-4 db	

NOTE: Output from oscillator must be constant and stable.

3. Repeat for other channel. Alignment of pointers for same output from each channel should be close.

### RECORD SIGNAL-NOISE RATIO

1. Set audio oscillator and RADIO/PHONO level controls for minimum.
2. Overall signal-noise ratio should read on the VTVM:

7 1/2 i.p.s.	below -48 db	(.0031 volts rms)
3 3/4 i.p.s.	below -43 db	(.0055 volts rms)

### MICROPHONE AMPLIFIER CHECK

1. Connect audio oscillator to left channel microphone input through a 1000:1 voltage divider. (A 10,000 ohm resistor in series with a 10 ohm resistor, one end at ground, output to microphone input from across 10 ohm resistor.) Set audio oscillator to 500 cycles and output of .6 volts. (With 1000:1 divider, this feeds .6 millivolts to microphone input.)
2. With RADIO/PHONO level control set to minimum, adjust MICROPHONE level control towards maximum. Should be able to adjust for maximum normal indication on record meter and an output of -2 db (.62 volts rms).
3. Adjust MICROPHONE level control for output of -22 db (.062 volts rms). Check output at 50 cycles, 5 KC, and 10 KC. Output should be  $\pm 2$  db from 500 cycle tone.
4. Repeat for right channel.

NOTE: Oscillator output must be stable and uniform.

### V-4. ERASE PERFORMANCE

1. Erase head height should be adjusted for optimum erasure of both tracks. This is done by erasing a previously recorded tape (i.e. recorder in record mode, recording level controls minimum) and observing playback output. A bias trap is necessary between playback output and AC VTVM to eliminate interference of bias oscillator frequency.
2. Tape for above test recorded at a saturated 400 cycle signal level. A saturated tape is one on which the record level has been reduced .5 db from the level above which no further output is realized.
3. Erasure of above tape should reduce signal 55 db or more.

### CROSSTALK

1. Record on left channel a 500 cycle tone at maximum normal level, (-2 db output), erasing the right channel.
2. Rewind.
3. Playback the recorded 500 cycle tone. Observe output of adjacent right channel. Attenuation of pickup from adjacent channel should be greater than -50 db.
4. Repeat for right channel.

### V-5. FLUTTER AND WOW CHECK

Flutter and wow should be checked on the flutter bridge, using manufacturers recommended hookup and procedures. Flutter measurements should be:

7 1/2 i.p.s.	less than	.25% rms
3 3/4 i.p.s.	less than	.32% rms

## BIAS TRAP

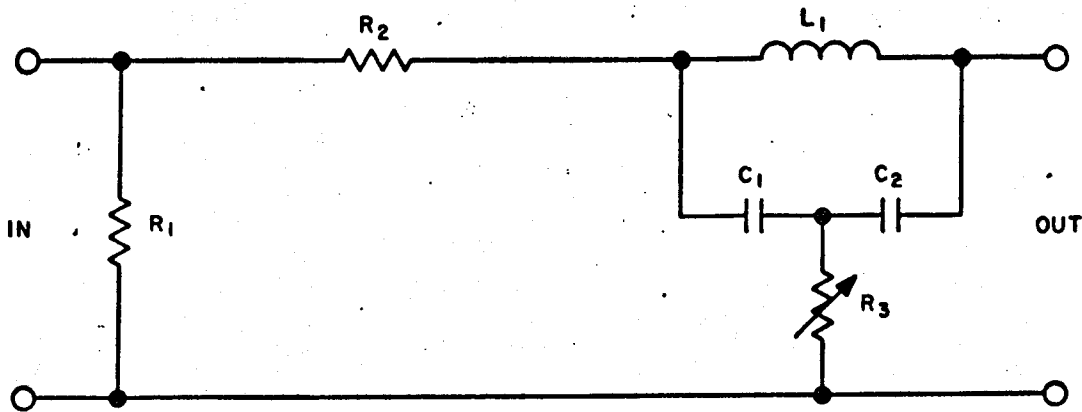

FIGURE V-1

### PARTS LIST:

- C<sub>1</sub>. 280 mmf Padder Condenser; Arco 464 or equivalent
- C<sub>2</sub>. 365 mmf max. Air Trimmer; Calrad CR-230 or equivalent
- R<sub>1</sub>. 270K ohms 1/2 watt resistor
- R<sub>2</sub>. 3.3K ohms 1/2 watt resistor
- R<sub>3</sub>. 150K ohms Potentiometer.
- L<sub>1</sub>. 20 MH Choke; Miller #691 or equivalent

Suggest construction of Bias Trap in a Bud #CU883 (4 X 4 X 2") or equivalent metal utility cabinet.

### ADJUSTMENT PROCEDURE

1. Connect 100 Kc signal to input: connect AC VTVM to output.
2. Set C<sub>2</sub> at mid-point and R<sub>3</sub> at maximum resistance.
3. Adjust C<sub>1</sub> for 100 Kc dip (minimum output).
4. Adjust R<sub>3</sub> for maximum attenuation.

When adjusted by the above procedure, this Bias Trap will give over 65 DB attenuation. Bias Frequency of Ampex Recorder may vary from 90 to 110 Kc; C<sub>2</sub> should be mounted with exterior knob in order that the Bias Trap may be adjusted to individual recorder's bias frequency.



# VI. SCHEMATICS

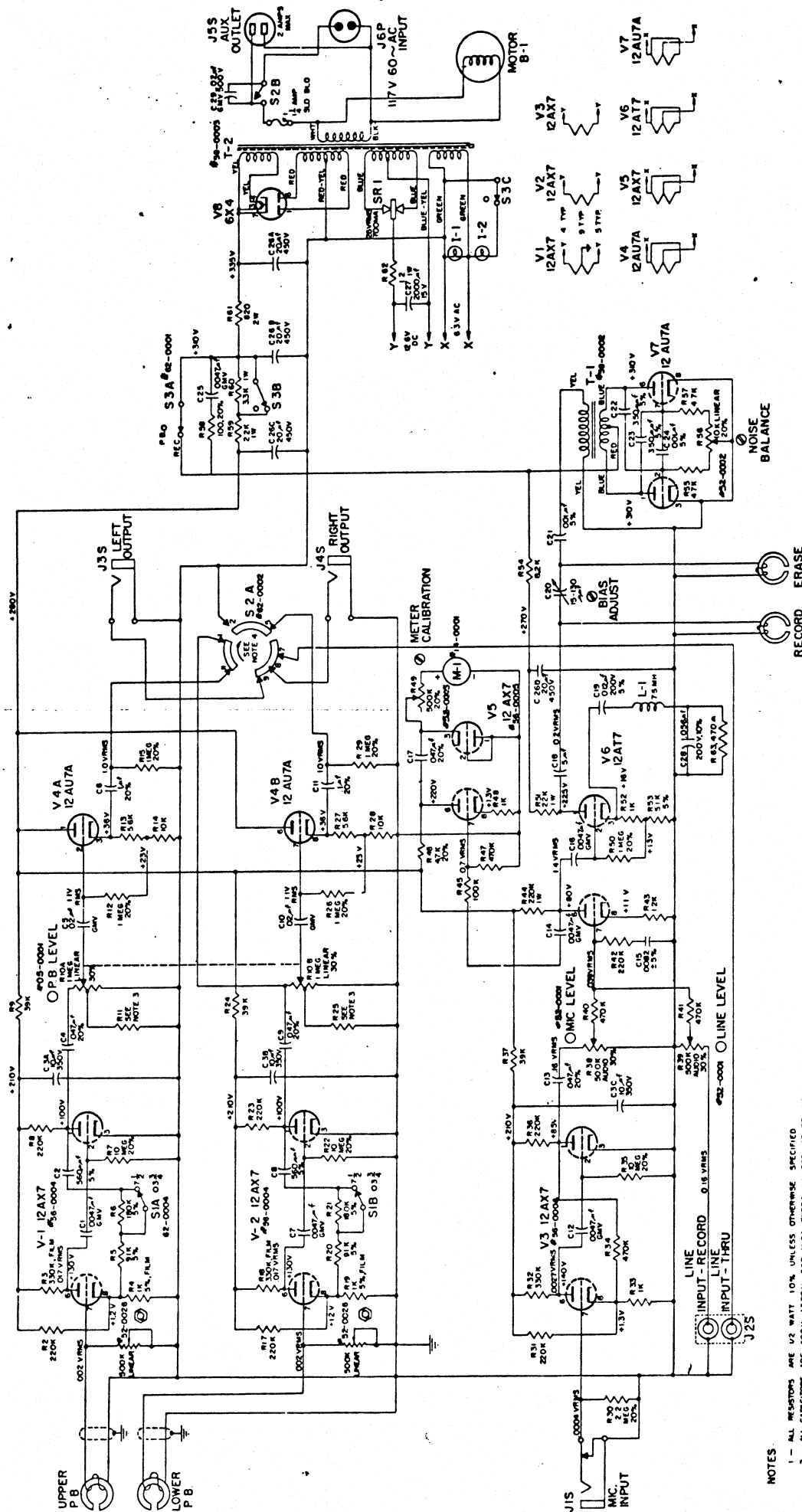

FIGURE VI-1. SCHEMATIC - 900 - 920 SERIES

- NOTES
- 1 - ALL RESISTORS ARE 1/2 WATT 10% UNLESS OTHERWISE SPECIFIED
  - 2 - ALL CAPACITORS ARE 400V (500V FOR MICA TYPE) UNLESS OTHERWISE SPECIFIED
  - 3 - R11 AND R23 ARE FACTORY SELECTED TO MATCH TRACKING OF RD. VALUES RANGE FROM 56K TO 82K.
  - 4 - S2 SHOWN IN OFF POSITION VIEWED FROM SWAPT END OF SWITCH
  - 5 - "ON" (LEFT & RIGHT OUTPUT CONNECTED TO LINE INPUT-THRU)
  - 6 - "MONITOR" (LEFT & RIGHT OUTPUT CONNECTED TO UPPER PLAYBACK CHANNELS)
  - 7 - "SINGLE" (LEFT & RIGHT OUTPUT CONNECTED TO UPPER & LOWER PLAYBACK CHANNELS)
  - 8 - "STEREO" (LEFT & RIGHT OUTPUT CONNECTED TO UPPER & LOWER PLAYBACK CHANNELS)
  - 9 - ALL VOLTAGES MEASURED WITH 117V AC LINE INPUT WITH MACHINE IN RECORD MODE, 7 1/2 IPS TAPE SPEED, LEVEL CONTROLS FULL COUNTERCLOCKWISE ROTATION. DC VOLTAGES MEASURED WITH 20,000 OHM PER VOLT METER. AC VOLTAGES MEASURED WITH AC-VOLTCOM FULCRUM VOLTCOMETER (IMP-4000 OR EQUAL) AT 300 CYCLES SUBSTITUTING A 1K RESISTOR FOR RECORD HEAD & SUBSTITUTING A 20K, 10-WATT RESISTOR FOR V7 (PINS 1 & 6 TIED TOGETHER & THE RESISTOR BETWEEN THIS JUNCTION & PIN 3)

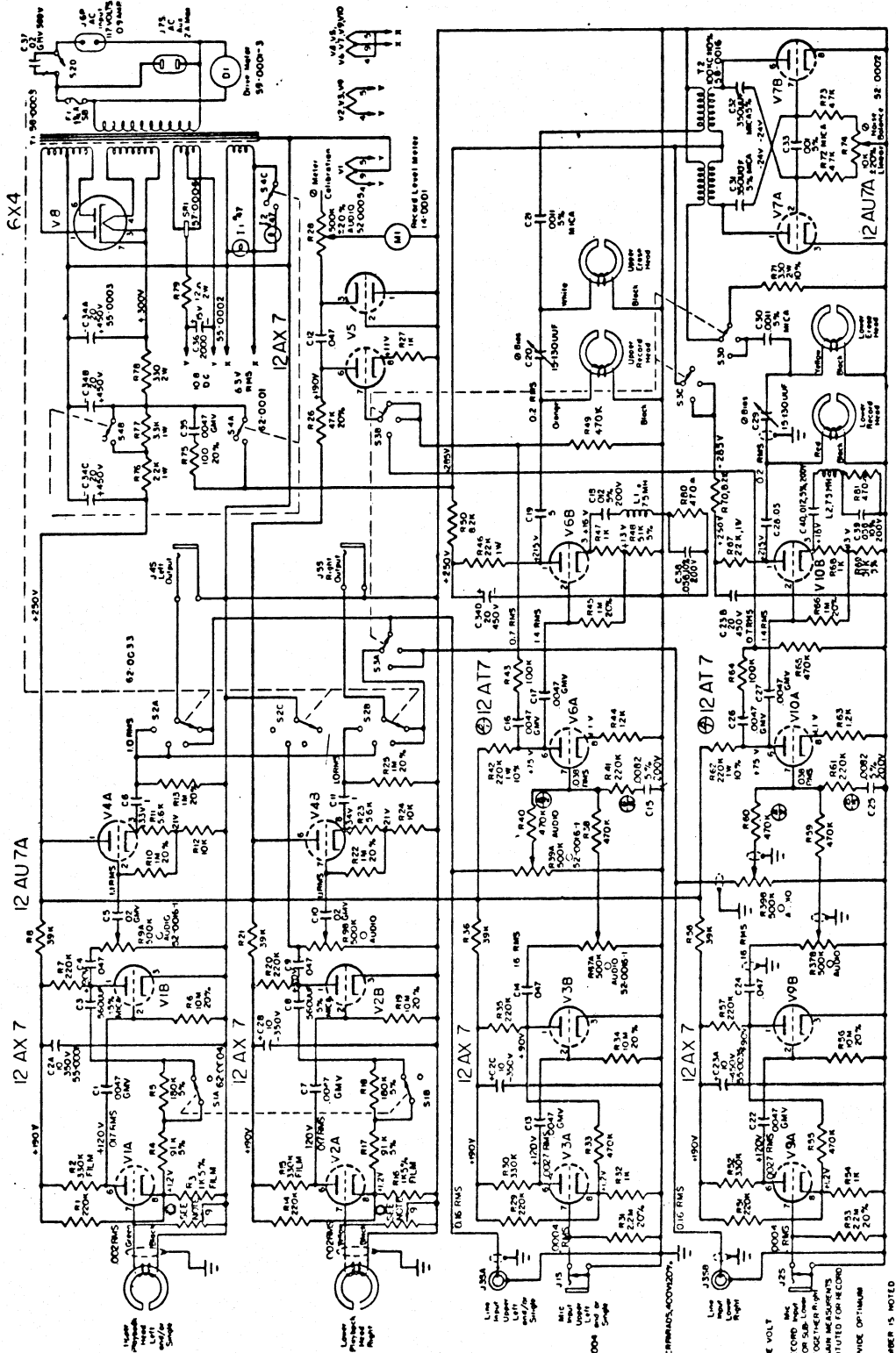

FIGURE VI-2. SCHEMATIC - 950-970 SERIES

- NOTES:**
- 1- SWITCHES SHOWN IN CCW POSITION - 7 1/2 IPS POSITION - PLAYBACK POSITION
  - 2- V1, V2, V3, V4 - SELECT REAR PART 94-0004
  - 3- V5 - 6A7-5A-0003
  - 4- V6, V7, V8 - 6-000 OHM
  - 5- V9 - 6-000 OHM
  - 6- ALL NON-ELECTROLYTIC CAPACITORS CAPACITY IN MICROFARADS, UNLESS OTHERWISE NOTED
  - 7- ALL RESISTORS 1/2 WATT ±0%, UNLESS OTHERWISE NOTED
  - 8- C2, C3, C4, C5, C6, C7, C8, C9, C10, C11, C12, C13, C14, C15, C16, C17, C18, C19, C20, C21, C22, C23, C24, C25, C26, C27, C28, C29, C30, C31, C32, C33 - ALL 50V TAGGED AND MEASURED WITH A 2000 OHM PER VOLT METER
  - 9- ALL AC VOLTAGES MEASURED WITH AC VACUUM TUBE VOLT METER IN GOOD OR EQUALITY VOLT LINE, VOLUME CONTROLS FULL CW ROTATION AND MACHINE IN RECORD POSITION
  - 10- ALL DC VOLTAGES MEASURED WITH DC VACUUM TUBE VOLTMETER FROM THIS JUNCTION TO PIN 3, GAIN MEASUREMENTS TAKEN AT SUSTAINABLE WITH A 1K RESISTOR SUBSTITUTED FOR RECORD
  - 11- PLAYBACK FREQUENCY RESPONSE
  - 12- CONTROLS ARE FACTORY ADJUSTED TO PROVIDE OPTIMUM
  - 13- DIMENSIONS FOR SPACED PARTS AMPER PART NUMBER IS NOTED ON FIRST OR 2<sup>ND</sup> SECTION.

## VII. PARTS LIST (with exploded views)

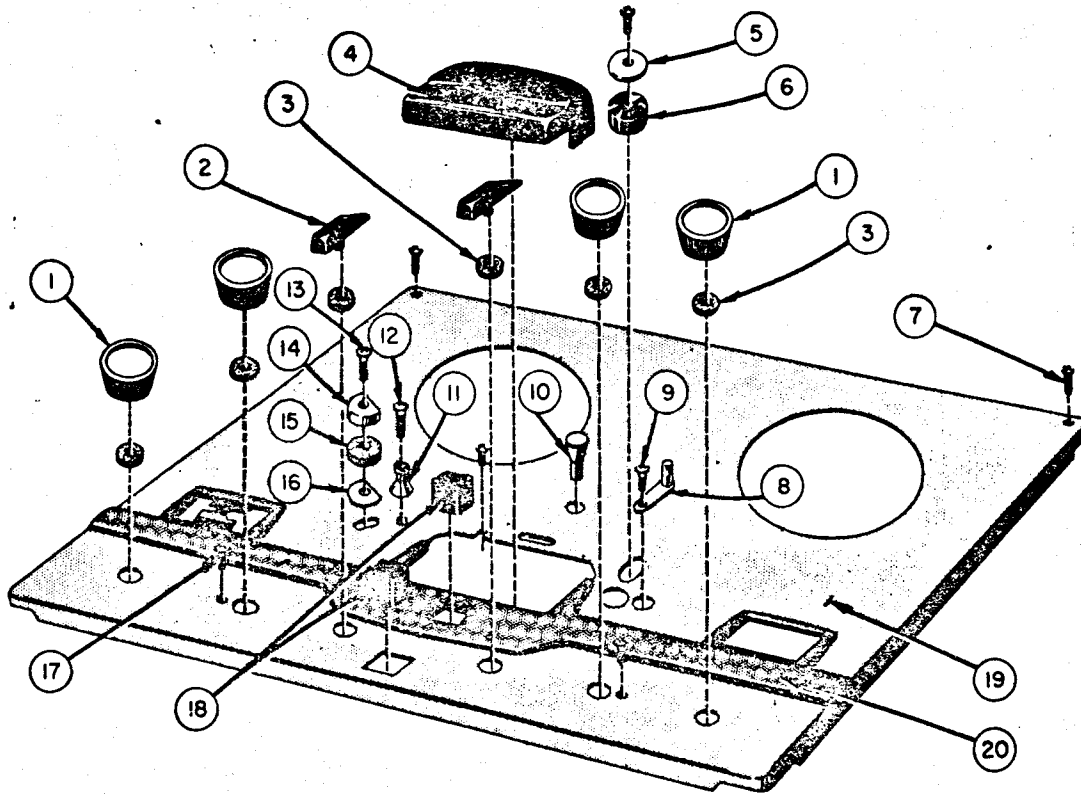

FIGURE VII-1. MECHANICAL—ABOVE TOP PLATE

REF #	DESCRIPTION	CATALOG NUMBER		
		GREY	BROWN	BEIGE
1	Control Knobs "A" Series and 900 Series monaural record. Selector, Listening, Radio/Phono, or Microphone. Knob with arrow	10-0033-1	10-0005-3	10-0022
	950 Series, stereo record. Top: Selector, Listening, Radio/Phono, or Microphone	10-0033-2		10-0019
	Bottom: Selector, Listening Radio/Phono, or Microphone	10-0024-1		10-0021
	936 Model	10-0033-1		
2	Bar Knobs Models			
	Fastwinding, Play or Record Control Knob	10-0032-1	10-0032-3	10-0032-2
3	Washer, Felt	44-0026-1	44-0026-1	44-0026-1
4	Head Cover, with opening for head shift rod, Universal playback, Polystyrene	29-0034-3	29-0034-4	29-0034-5

REF #	DESCRIPTION	CATALOG NUMBER		
		GREY	BROWN	BEIGE
	Model 934, 936	29-0034-7		
	Head Cover, without opening "A" Series	29-0034-1	29-0034-2	
5	Cover, Capstan Idler	29-0032-1	29-0032-2	29-0032-3
6	Capstan Idler, for top and bottom washers use 44-0027-3	04-0020-1	04-0020-1	04-0020-1
7	Screw, Cover Plate 6/32 X 1/4"	40-0080	40-0079	40-0114
8	Automatic Stop Arm Assembly	04-0057-1	04-0057-2	04-0057-3
9	Screw, Machine 4-40 X 1/4"	40-0093	40-0094	40-0115
10	Button, Speed Control Uses Set Screw 4-40 X 1/8" Bristol Head #40-0057; Allen Head #40-0111	10-0009-1	10-0009-2	10-0009-3
11	Tape Guide	21-0004	21-0004	21-0004
12	Screw, Machine 4-40 X 3/4", Phillips	40-0056	40-0078	40-0113
13	Screw, Machine 4-40 X 1/4", Phillips	40-0055	40-0077	40-0112
14	Cover, Tape Holdback	29-0033-1	29-0033-2	29-0033-3
15	Washer, Felt Tape Holdback	44-0026-2	44-0026-2	44-0026-2
16	Base, Tape Holdback	33-0004-1	33-0004-1	33-0004-1
17	Screw, 6/32 X 3/8"	40-0065-1	40-0065-1	40-0065-1
18	Pushbutton, Stop, and Press to Record	10-0007-1	10-0007-2	10-0007-3
	Model 934 and 936	10-0007-4		
19	Cover Assembly, with Escutcheon, "A" Series Models A-122, 121, 124 without automatic stop; for cover assembly with top mounting screws (Ref. #7) add A to part number.	04-0019-2	04-0019-3	
	Cover Assembly with Escutcheon Models A-111, A-112, and A-114	04-0019-1		
	Cover Assembly, Escutcheon 902, 904, 910, with Automatic Stop Assembly	04-0019-5 (light grey) or 04-0254-1 (charcoal grey)	04-0019-6	04-0019-7
	Cover Assembly with Escutcheon Models 952, 954, 960 with Automatic Stop Assembly	04-0019-8 (light grey) or 04-0254-2 (charcoal grey)		04-0019-9
	Cover Assembly, 934	04-0268-3		
	Cover Assembly, 936	04-0268-1		
20	Escutcheon	11-0017-1	11-0017-2	11-0017-3
	Models 934, 936	11-0091-1		

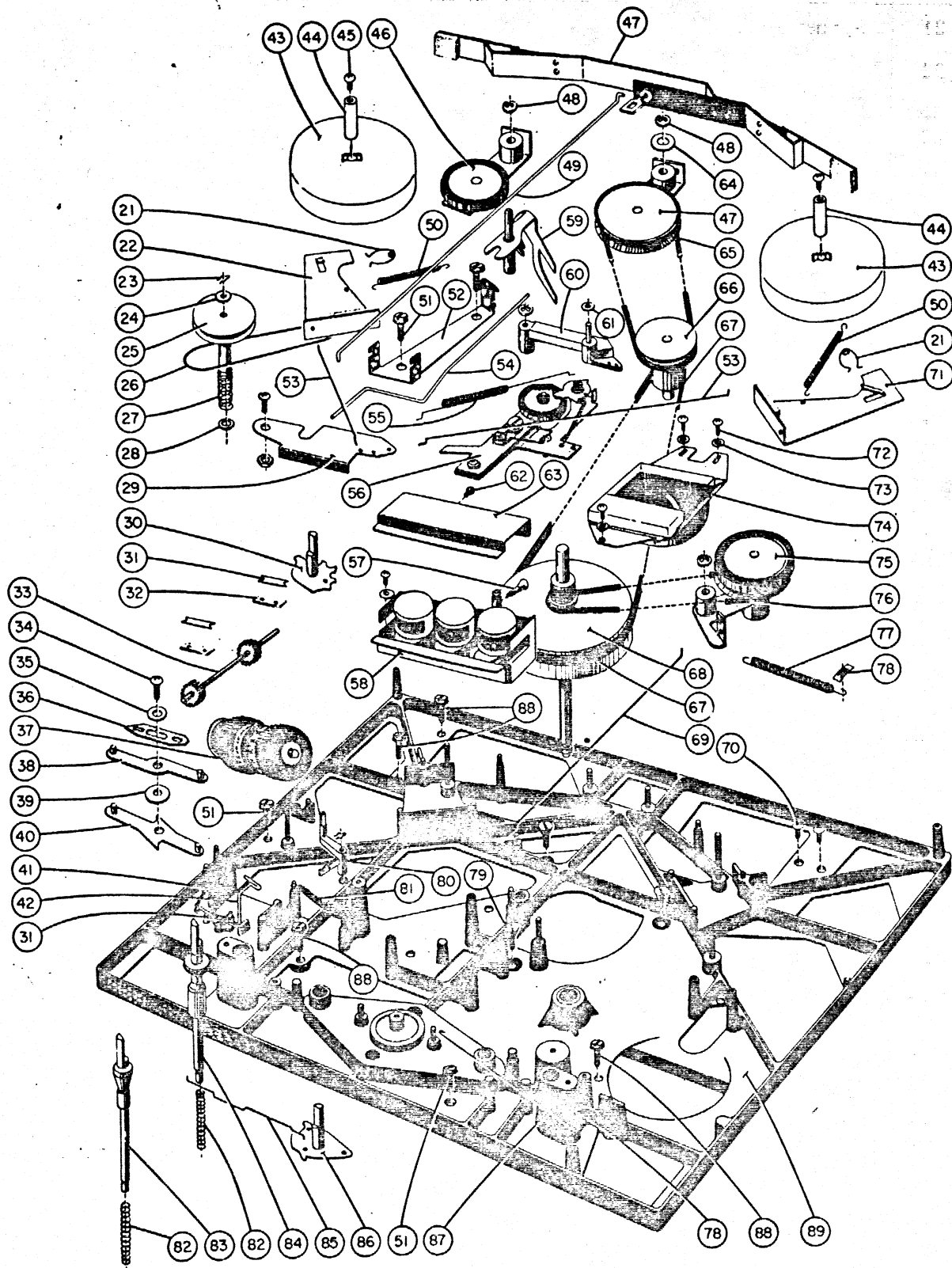

FIGURE VII-2. BASE PLATE TO TOP PLATE

REF #	DESCRIPTION	PART NUMBER
21	Spring Brake	27-0014-1
22	Brake Arm Assembly, Rewind, with felt Replace Felt with Kit #85-0018	04-0029-1
23	Retainer, Hair Pin Steel	32-0007
24	Washer, Cambric	44-0027-4
25	Worm Pulley Assembly	04-0023
26	"O" Ring Position Indicator	31-0003
27	Spring, Worm Counter Drive	24-0003
28	Washer, Cambric	44-0027-4
29	Brake Lever	23-0020-1
30	Cam Assembly, Fast Wind	04-0027-1
31	Spring, Retainer	27-0004-1
32	Rad, Retainer	13-0016-1
33	Jack Shaft Assembly, Counter Drive	03-0001-1
34	Screw, Machine, Phillips 6-32 X 1/4"	40-0054
35	Washer	44-0029-3
36	Shuttle, Interlock	23-0016-1
37	Position Indicator Assembly, Grey Position Indicator Assembly, Brown Position Indicator Assembly, Beige	02-0042-1 02-0042-2 02-0042-4
38	Arm Assembly, Upper Cam Control	04-0032-1
39	Washer	44-0024-3
40	Arm Assembly, Lower Cam Control	04-0031-1
41	Spring, Position Indicator Latch	27-0003-1
42	Latch Escapement	23-0002-1
43	Turntable Assembly, Grey Turntable Assembly, Brown Turntable Assembly, Beige	04-0026-1 04-0026-2 04-0026-3
44	Chrome Cap, Turntable Shaft, Grey Gold Cap, Turntable Shaft, Brown Brass Cap, Turntable Shaft, Beige	21-0019-1 21-0019-2 21-0019-3
45	Screw, Turntable Shaft, 4-40 X 1/4" Chrome for Grey Recorders Gold for Brown Recorders Brass for Beige Recorders	40-0055 40-0077 40-0112

REF #	DESCRIPTION	PART NUMBER
46	Rewind Idler Assembly	03-0004
47	Fastwind Pulley Assembly, includes Pulley, Brake Arm Assembly, Fastwind-Holdback Felts. For Felt Replacement only use Kit #85-0018	03-0003
48	"E" Ring Retainer, .187 Shaft	32-0006-1
49	Rod, Control, Fastwind	21-0023-1
50	Spring, Brake De-Energizing	27-0011
51	Screw, Self Tapping 8 X 1/4"	40-0067
52	Bracket, Detent	26-0012-1
53	Rod, Control, Brake Release	21-0022-1
54	Wire, Dual Speed Detent and Equalization	23-0021-1
55	Spring, Capstan Idler: Transports with Automatic Stop Assembly Transport without Automatic Stop	27-0025-1 27-0009-1
56	Automatic Stop Assembly (available as a complete assembly only) does not include shutoff lever arm, or screw. See Ref. #8 and #9. Spring, Automatic Stop return	02-0059-1 27-0020
57	Rod, Head Shift, for stacked post and plate assembly For cast post and plate assembly	21-0033-1 21-0079
58	Head Assembly: 900 Series, Half-Track Erase, Half-Track Record, Universal Playback	02-0062-6
	Stereo Erase, Stereo Record, Universal Playback	02-0062-7
	"A" Series: Half-Track Erase, Half-Track Record, Half-Track Playback	02-0062-1
	Half-Track Erase, Half-Track Record, Stereo Playback	02-0062-2
59	Yoke Assembly - Speed Change - Sixty (60) Cycles Fifty (50) Cycles	04-0033-1 04-0033-2
60	Capstan Idler Arm Assembly	04-0025-1
61	Washer, Cambric	44-0027-3
62	Screw, 6/32 X 1/4"	40-0054
63	Mu-Metal Head Cover	04-0021-2
64	Washer, Bowed Tension	44-0032
65	"O" Ring, Fast Forward	31-0001-1
66	Pulley, Motor 60 cycles used with Red Pulley, Motor 50 cycles used with Yellow Pulley, Motor 60 cycles used with Red Pulley, Motor 50 cycles used with Yellow Pulley Set Screw	25-0013-1 25-0013-2 25-0013-3 25-0013-4 40-0064

REF #	DESCRIPTION	PART NUMBER
67	Belt, Capstan Drive	31-0015-1
68	Capstan Assembly, uses Cambric Washer #44-0027-2 and Ball Bearing #20-0007	04-0024-1
69	Rod, Control, Play Takeup	21-0020-1
70	Screw, Machine, Phillips 8/32 X 5/16"	40-0063
71	Brake Arm Assembly, Takeup with lining. Replace Felt with Kit #85-0018	04-0030-1
72	Screw, Machine, Phillips 6/32 X 1/4"	40-0054
73	Washer, Lock	44-0031
74	Meter, Recording Level, Grey Meter, Recording Level, Brown Meter, Recording Level, Beige	14-0001-1 14-0001-2 14-0001-4
75	Play Takeup Assembly	03-0005-1
76	"O" Ring Takeup	31-0002
77	Spring, Play Takeup	27-0013-1
78	Push on Retainer	32-0001
79	Screw, Self Tapping 6/32 X 1"	40-0068
80	Arm, Holdback	23-0019-1
81	Spring, Holdback Tension	27-0011-1
82	Spring, Shaft Return	27-0012-1
83	Cam, Shaft Stop	23-0017-1
84	Cam, Shaft Record	23-0018-1
85	Rod Control, Holdback Tension	21-0021-1
86	Cam Assembly, Play Control	04-0028-1
87	Spring, Shuttle Return	27-0010-1
88	Screw, Self-Tapping 6 X 1"	40-0053
89	Base Plate Sub-Assembly	04-0034-1



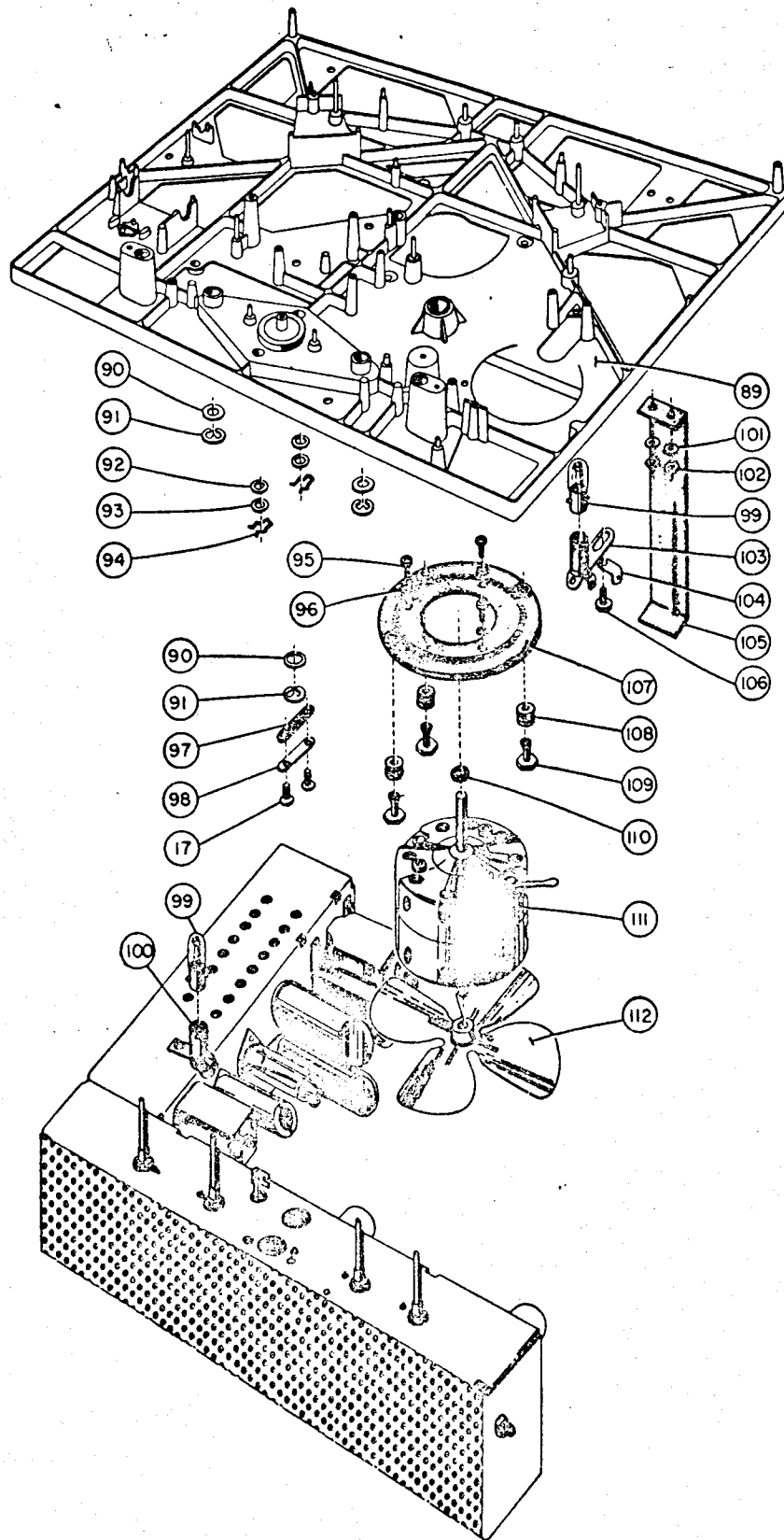
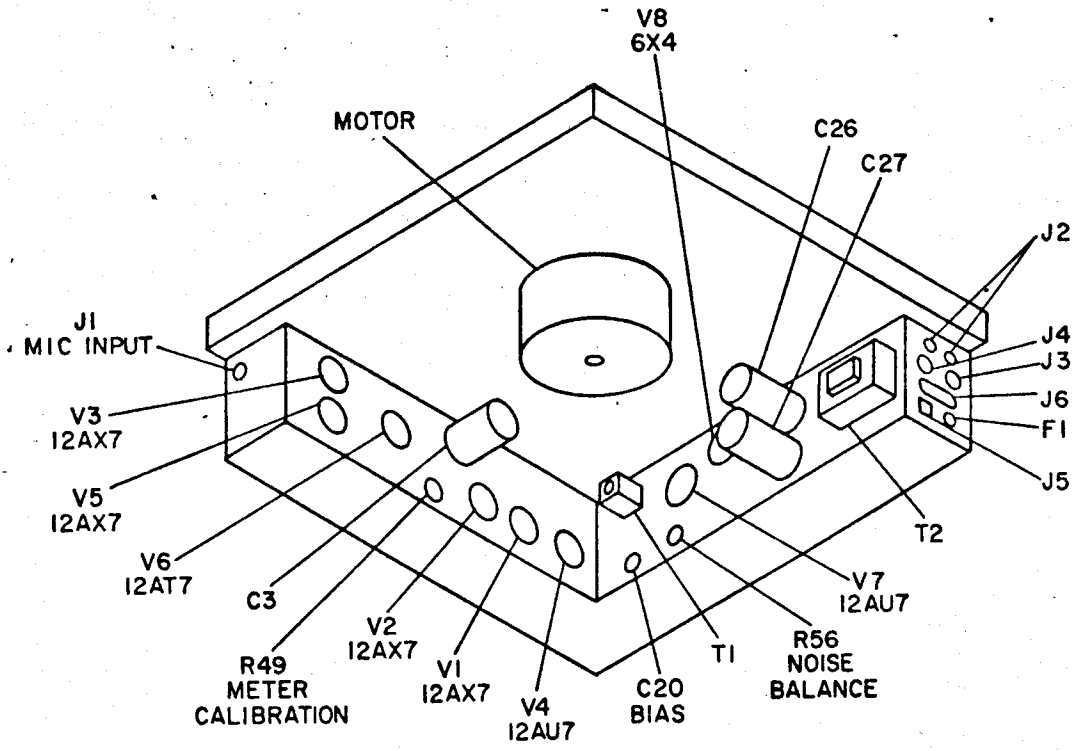
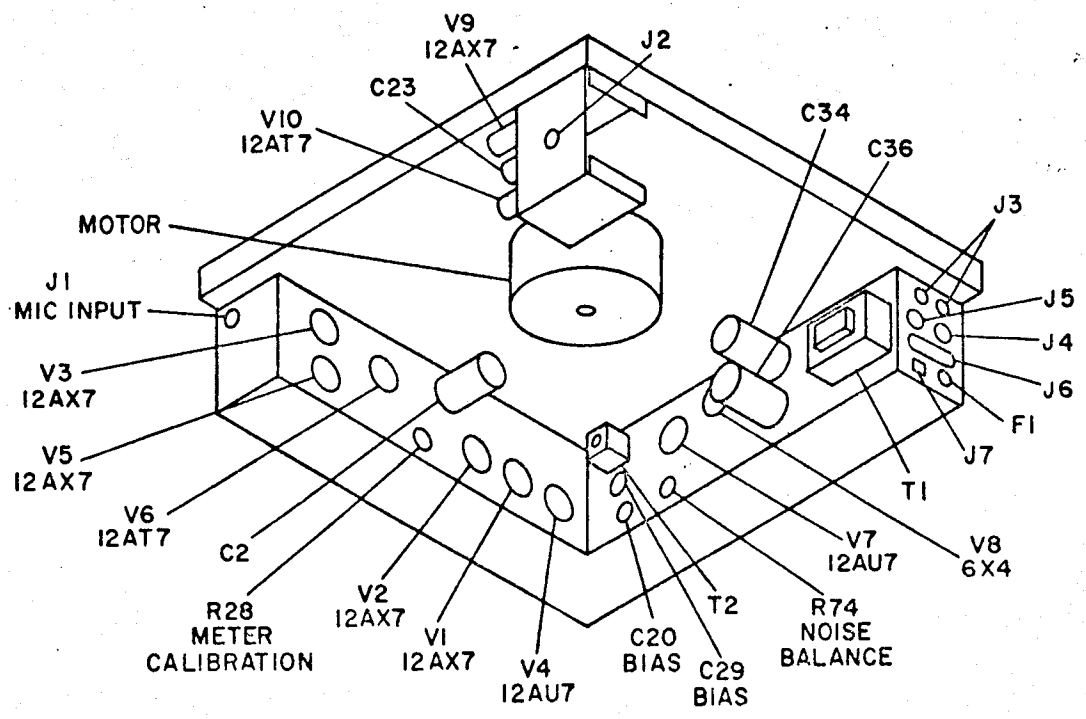

FIGURE .VII-3. VIEW BELOW BASE PLATE

REF #	DESCRIPTION	PART NUMBER
90	Washer, Cambric	44-0027-2
91	Retainer, "E" Ring	32-0008
92	Washer, Rubber	44-0030
93	Washer, Steel	44-0029-2
94	Retainer, Hairpin	32-0007
95	Screw, Phillips 8-32 X 5/16"	40-0063
96	Washer	44-0031
97	Retainer, Capstan Thrust, Nylon	33-0007-1
98	Retainer, Capstan Thrust, Steel	33-0007-2
99	Lamp 6-8V .15 amp GE #47	61-0002
100	Pilot Light Holder	63-0009
101	Washer, included with Ref. #102 (Monaural Recorders)	
102	Nut, Kep, with washer	42-0004
103	Pilot Light Holder	63-0009
104	Solder Lug	65-0003
105	Bracket, Transport Mounting (Monaural Recorders) Right Channel Record Sub-Assembly (Stereo Recorders) not available	
106	Screw, Self-Tapping 6 X 1/4"	40-0069
107	Mounting Plate, Motor Assembly	33-0005-1
108	Shockmount, Motor	13-0017
109	Sleeve Nut	42-0026-1
110	Washer, Felt	44-0026-1
111	Drive Motor, with Pulley	59-0001
112	Fan, Motor	25-0003



MODELS 900-920 SERIES



MODELS 950-970 SERIES

FIGURE VII-4. TUBE LAYOUTS

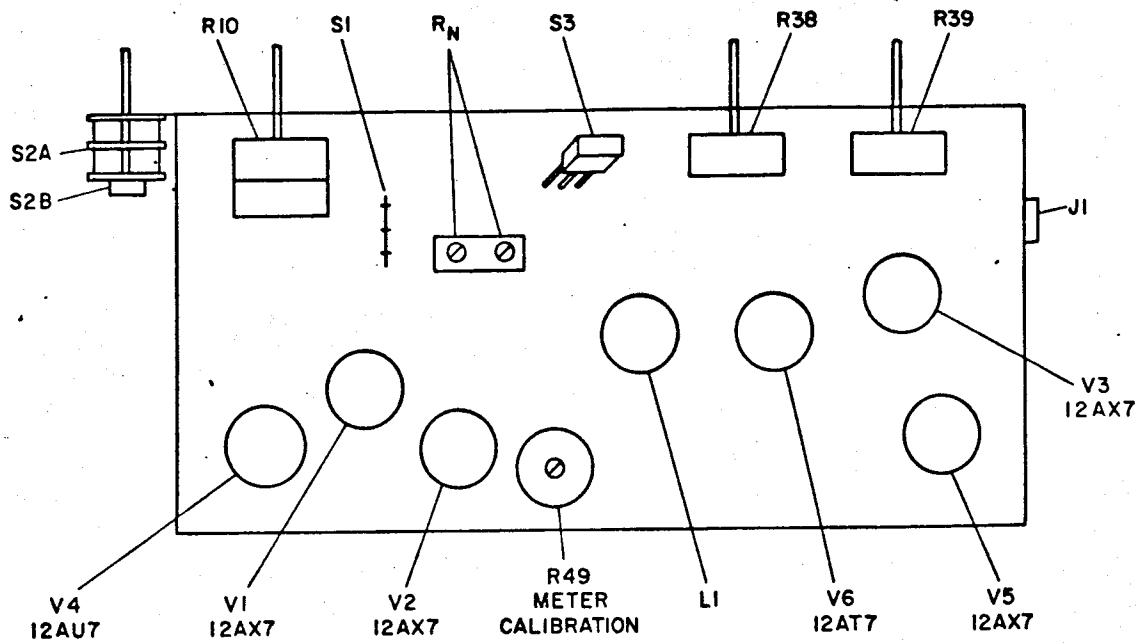

AMPLIFIER CHASSIS - BOTTOM VIEW

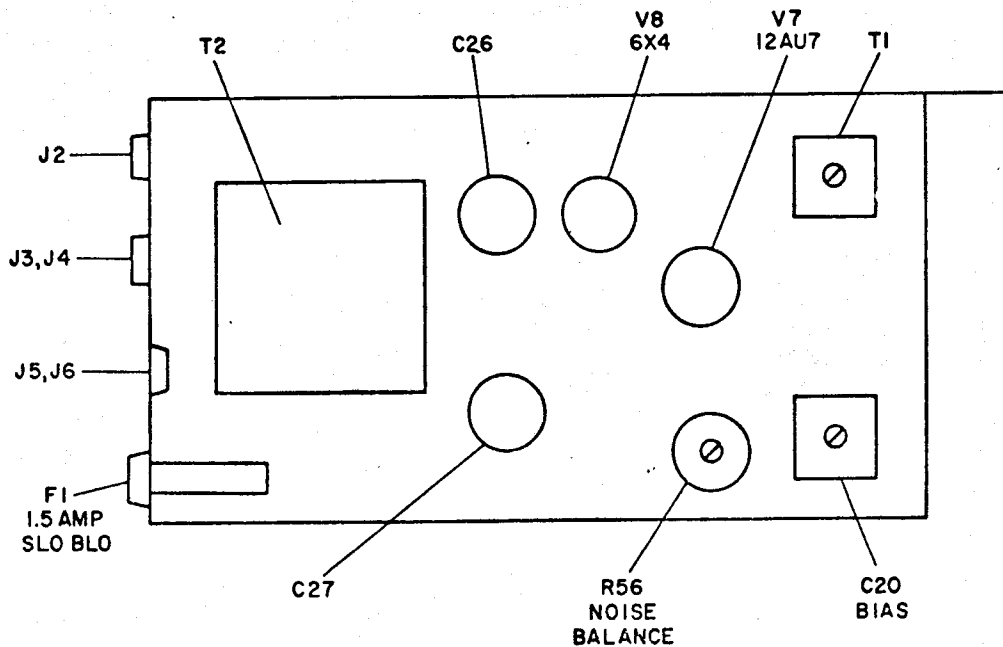

POWER SUPPLY CHASSIS - BOTTOM VIEW

FIGURE VII-5. CHASSIS LAYOUT - MODEL 900-920 SERIES

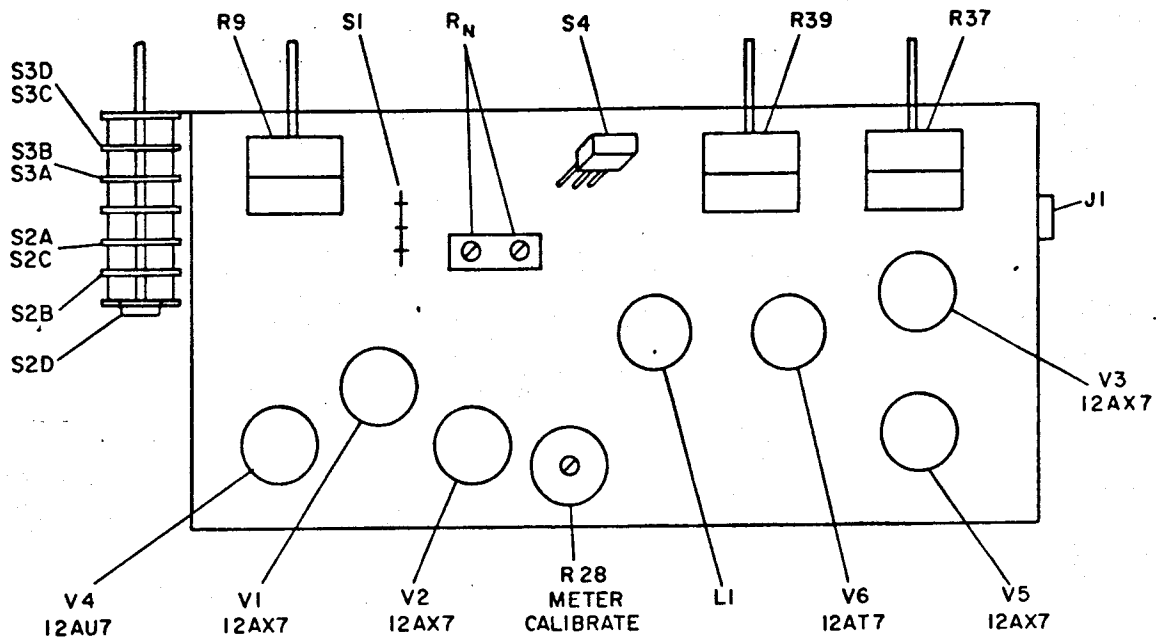

AMPLIFIER CHASSIS - BOTTOM VIEW

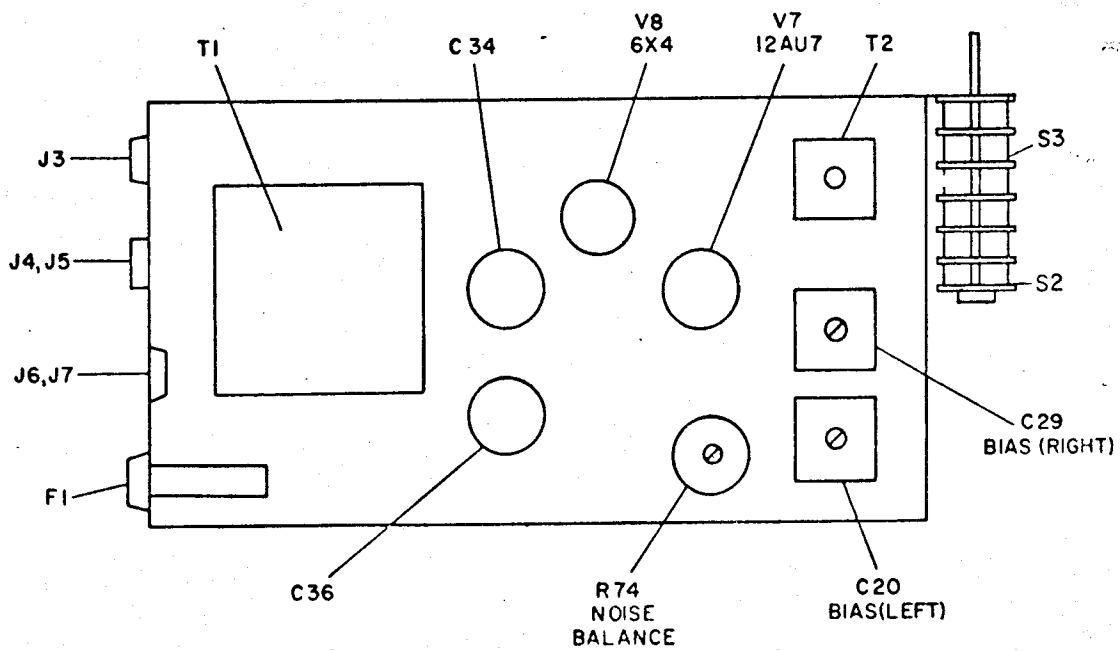

POWER SUPPLY CHASSIS - BOTTOM VIEW

FIGURE VII-6. CHASSIS LAYOUT - MODEL 950-970 SERIES

## VIII. TROUBLE SHOOTING

### A. CAPSTAN DOES NOT ROTATE

1. Pilot light at counter assembly does not light:
  - a. Check power cord. Plug in if not connected. Replace cord, if open.
  - b. If still inoperative, check fuse. Requires 1 1/4 amp slow blow. If fuse continues to blow, check for electrical shorts which cause an overload condition.
2. Pilot light at counter assembly is lit:
  - a. Drive belt may be jammed due to changing speed selector with power "OFF". Return speed selector to 3 3/4 i.p.s., and if capstan starts rotating, place in desired speed. Drive belt may have been damaged if in jammed position for considerable time.
  - b. Drive belt broken--replace.
  - c. Fastwind Idler Pulley (#47) frozen in bearing and prevents motor from turning. Replace fastwind assembly.

### B. TAPE LOOP THROWN AND/OR LOOSE PACK DURING PLAY MODE

1. Takeup turntable does not turn:
  - a. Turntable binds against topplate. Reposition topplate cover assembly to remove bind.
  - b. Play takeup clutch does not engage against takeup turntable. Check Spring (#77).
  - c. Play takeup belt off. If broken, replace. If slipped off, check takeup tension. If high or erratic tension, belt may be thrown off. Replace play takeup clutch.
2. Takeup slow:
  - a. Low takeup tension--check and service as described in service bulletin Ref. #77.
  - b. Turntable binding against topplate cover assembly; reposition topplate cover assembly.
  - c. Reel scraping topplate cover assembly. Reel may be warped, replace. Topplate cover assembly may not be fully screwed down.

### C. SPEED CHANGE MALFUNCTIONING

1. 3 3/4 i.p.s. slows down, stops, and/or high flutter.

- a. Drive Belt (#67) stretched due to being in 7 1/2 i.p.s. for excessive length of time. Replace drive belt.
2. Poor shift from 3 3/4 to 7 1/2.
    - a. Speed change yoke not properly adjusted, and/or Motor Pulley (#66) not properly set. Belt should ride between yoke prongs. Yoke prongs should be approximately 1/8" away from larger diameter pulley surface.
    - b. Drive Belt (#67) stretched. Change belt.
  3. Rubbing or grating sound in either speed.
    - a. Belt rubbing speed change yoke prongs. (Ref. C-2).

#### D. MODE KNOB DOES NOT ENGAGE

1. Capstan idler not returning Play Cam (#86) to neutral.
  - a. Check capstan return spring (#81). (Some older units, such as "A" Series, this spring was not used.)
2. Rewind Cam (#30) not returning to neutral.
  - a. Check Shuttle Return Spring (#87).
  - b. Check cam assembly for burrs or lack of lubrication, which might hinder proper movement of sliding parts. Lubricate, if necessary, with lubricant (Ampex Audio Part #71-0007).
3. Either control knob not engaging.
  - a. Check for shaft staking loose, allowing cam plate to slip.

#### E. COUNTER MALFUNCTIONS

1. Drum does not rotate or shift numbers.
  - a. Drum binding against escutcheon; check for burr on escutcheon, and clearance between escutcheon and drum.
  - b. Defective friction spring between drum and shaft. Check for burrs and improper lubrication. To lubricate, disassemble counter. Clean shaft, lubricate lightly entire shaft area with Dow Corning Silicone #200 (Ampex Audio Part #71-0021).

#### F. AUTOMATIC STOP MALFUNCTIONS

1. Shuts off before end of reel, Play/Record mode.
  - a. Check play takeup tension. If low, refer to Service Bulletin #77. Also, refer to section B of this trouble shooting section.

2. Shuts off before end of reel, fastwind.

- a. Low holdback tension--check that fastwind brake pad engages turntable.
- b. Low takeup torque--refer to mechanical checkout procedure; motor stall test. Possible causes: Fastwind Pulley Assembly, or Rewind Pulley frozen, or tight bearing.
- c. If none of the above, replace Automatic Stop Assembly.

3. Power cam on automatic stop continues to rotate.

- a. Assembly, or cam offset: Reposition so rubber tired cam in neutral position has the indented portion of rubber tire centered on the capstan shaft with 1/32" clearance between rubber tired cam and capstan shaft.

**G. MOTOR STALLS--REWIND**

1. With fully loaded reel on supply turntable, does not start or is very slow in either fastwind mode start.
  - a. Check both fastwind pulleys, if binding.
  - b. Low torque motor.
  - c. Stretched, or oily Fastwind Belt (#65).

**H. NOISY**

1. Noisy Rewind.

- a. Worn bearing or shaft in rewind idler assembly (#46).
- b. Noisy turntable shaft--lubricate shaft and/or replace turntable.

2. Noisy Play/Record Mode.

- a. Refer to Service Bulletin Ref. #77.

3. Noisy--rubbing sound.

- a. Belt rubbing on speed change yoke--refer to Section C--"Speed Change Malfunctions", Paragraph 3.

---

AMPEX CORPORATION  
Consumer And Educational Products Division  
2201 Landmeier Rd.  
Elk Grove Village, Illinois 60007

---