

MR-70

Recorder/Reproducer

Publication No. 4890145-10
January 1965

AMPEX CORPORATION
401 Broadway
Redwood City, California

Printed in U.S.A.

LIST OF EFFECTIVE PAGES

PAGE NUMBER	ISSUE IN EFFECT	PAGE NUMBER	ISSUE IN EFFECT	PAGE NUMBER	ISSUE IN EFFECT	PAGE NUMBER	ISSUE IN EFFECT
401084	A 1/65	401203	A 1/65	401040	A 1/65	401083	A 1/65
401085	A 1/65	401204	A 1/65	401041	A 1/65		
401086	A 1/65	401205	A 1/65	401042	A 1/65		
401087	A 1/65	401206	A 1/65	401043	A 1/65		
400901-1	A 6/64	401207	A 1/65	401044	A 1/65		
401182	A 1/65	401208	A 1/65	401045	A 1/65		
401183	A 1/65	401209	A 1/65	401046	A 1/65		
401184	A 1/65	401210	A 1/65	401047	A 1/65		
401185	A 1/65	401211	A 1/65	401048	A 1/65		
401186	A 1/65	401212	A 1/65	401049	A 1/65		
400901-2	A 6/64	401313	A 1/65	401050	A 1/65		
400922	A 1/65	401214	A 1/65	401051	A 1/65		
400924	A 1/65	401215	A 1/65	401052	A 1/65		
400926	A 1/65	400902-2	A 6/64	401053	A 1/65		
400928	A 1/65	401216	A 1/65	401054	A 1/65		
401006	A 1/65	401217	A 1/65	401055	A 1/65		
401007	A 1/65	400904-3	A 6/64	401056	A 1/65		
401008	A 1/65	400881	A 8/64	401057	A 1/65		
400901-3	A 6/64	401015	A 1/65	401058	A 1/65		
401009	A 1/65	401016	A 1/65	401059	A 1/65		
401010	A 1/65	401017	A 1/65	401060	A 1/65		
401011	A 1/65	401018	A 1/65	401061	A 1/65		
401012	A 1/65	401019	A 1/65	401062	A 1/65		
401013	A 1/65	401020	A 1/65	401063	A 1/65		
401014	A 1/65	401021	A 1/65	401064	A 1/65		
400904-4	A 6/64	401022	A 1/65	401065	A 1/65		
401187	A 1/65	401023	A 1/65	401066	A 1/65		
401188	A 1/65	401024	A 1/65	401067	A 1/65		
401089	A 1/65	401025	A 1/65	401068	A 1/65		
401190	A 1/65	401026	A 1/65	401069	A 1/65		
401191	A 1/65	401027	A 1/65	401070	A 1/65		
401192	A 1/65	401028	A 1/65	401071	A 1/65		
401193	A 1/65	401029	A 1/65	401072	A 1/65		
401194	A 1/65	401030	A 1/65	401073	A 1/65		
401195	A 1/65	401031	A 1/65	401074	A 1/65		
401196	A 1/65	401032	A 1/65	401075	A 1/65		
401197	A 1/65	401033	A 1/65	401076	A 1/65		
401198	A 1/65	401034	A 1/65	401077	A 1/65		
401199	A 1/65	401035	A 1/65	401078	A 1/65		
401200	A 1/65	401036	A 1/65	401079	A 1/65		
401201	A 1/65	401037	A 1/65	401080	A 1/65		
400904-1	A 6/64	401038	A 1/65	401081	A 1/65		
401202	A 1/65	401039	A 1/65	401082	A 1/65		

TABLE OF CONTENTS

		<u>Page</u>
Section 1	DESCRIPTION	
1.1	General	1-1
1.2	Tape Transport	1-1
1.3	Electronic Assembly	1-2
1.4	Specifications	1-2
Section 2	INSTALLATION	
2.1	Unpacking	2-1
2.2	Preliminary to Installation	2-2
2.3	Mounting	2-2
2.4	Interconnecting Components	2-3
2.5	Connecting Signal Lines	2-3
2.6	Connecting Power	2-4
2.7	Location of Plug-In Units	2-4
2.8	Strapping for 115 or 230 Volt Power Source	2-5
2.9	Output Line Selection	2-6
2.10	Connecting Accessory Equipment or Installing Jumper Plugs	2-6
2.11	Adjusting Reel Turntable Height	2-7
Section 3	OPERATING INSTRUCTIONS	
3.1	General Instructions	3-1
3.2	Controls and Indicators	3-2
3.3	Tape Threading	3-3
3.4	Recording	3-3
3.5	Reproducing (Playback)	3-4
3.6	Use of Fastwinding Mode	3-4
3.7	Editing	3-5
3.8	Operating from Optional Remote Control Unit	3-5
3.9	Recording Sound-On-Sound	3-6
Section 4	TRANSPORT MAINTENANCE	
4.1	Routine Maintenance	4-1
4.2	Corrective Maintenance	4-5
4.3	Principles of Operation	4-8
Section 5	ELECTRONIC MAINTENANCE	
5.1	General	5-1
5.2	Checkout and Adjustment Using Standard Tape	5-1
5.3	Checkout and Adjustment Without Standard Tape	5-6
5.4	Low Frequency Head Compensation	5-7
5.5	Principles of Operation	5-8
Section 6	HEAD ASSEMBLY	
6.1	General	6-1
6.2	Maintenance of Head Assemblies	6-1
6.3	Track Widths	6-2
Section 7	PARTS LISTS AND DRAWINGS	

LIST OF ILLUSTRATIONS

	<u>Page</u>
Figure 1-1	1-1
1-2	1-2
2-1	2-1
2-2	2-7
3-1	3-2
3-2	3-2
3-3	3-3
4-1	4-1
4-2	4-2
4-3	4-5
4-4	4-7
4-5	4-8
4-6	4-8
4-7	4-9
5-1	5-5
5-2	5-10
5-3	5-10
5-4	5-10
5-5	5-11
5-6	5-11
5-7	5-12
7-1	Schematic Diagram—Transport, Power Supply
7-2	Schematic Diagram—Transport, Motor Control
7-3	Schematic Diagram—Transport, Logic Section
7-4	Schematic Diagram—Electronics, Power Supply
7-5	Schematic Diagram—Electronics, Record Section
7-6	Schematic Diagram—Electronics, Reproduce Section
7-7	Schematic Diagram—Master Bias Oscillator
7-8	Schematic Diagram—Bias Amplifier Module
7-9	Schematic Diagram—Output Amplifier Module
7-10	Schematic Diagram—Remote Control, Transport
7-11	Schematic Diagram—Sel-Sync Amplifier Module
7-12	Schematic Diagram—Microphone Preamplifier, 40 db
7-13	Schematic Diagram—Microphone Preamplifier, 60 db

DESCRIPTION**1.1 GENERAL**

The Ampex Model MR-70 Magnetic Tape Recorder/Reproducer is a high quality equipment designed for use in the professional recording field. The recorder is available mounted in a console (see Fig. 1-1) or unmounted for installation in a standard 19-inch rack.

While the MR-70 is compatible with other Ampex recorders, major improvements have been made in such areas as signal-to-noise, distortion, and flutter. The use of high grade Nuvistors in conjunction with rugged construction techniques assures maximum reliability and performance.

The equipment consists basically of a tape transport assembly and electronic assemblies as required (one for each channel). Accessory plug-in items are available from Ampex that will add to the versatility of the machine.

1.2 TAPE TRANSPORT

Tape transports (see Fig. 1-2) are available for 1/4-inch, 1/2-inch, and 1-inch magnetic tape. Head assemblies for 1/4-inch tape may be ordered with 1 or 2 tracks; for 1/2-inch tape with 2, 3, or 4 tracks; and for 1-inch tape with 3, 4, 6, or 8 tracks. Two tape speeds are provided on all transports--either 7-1/2 and 15 ips (inches per second) or 15 and 30 ips.

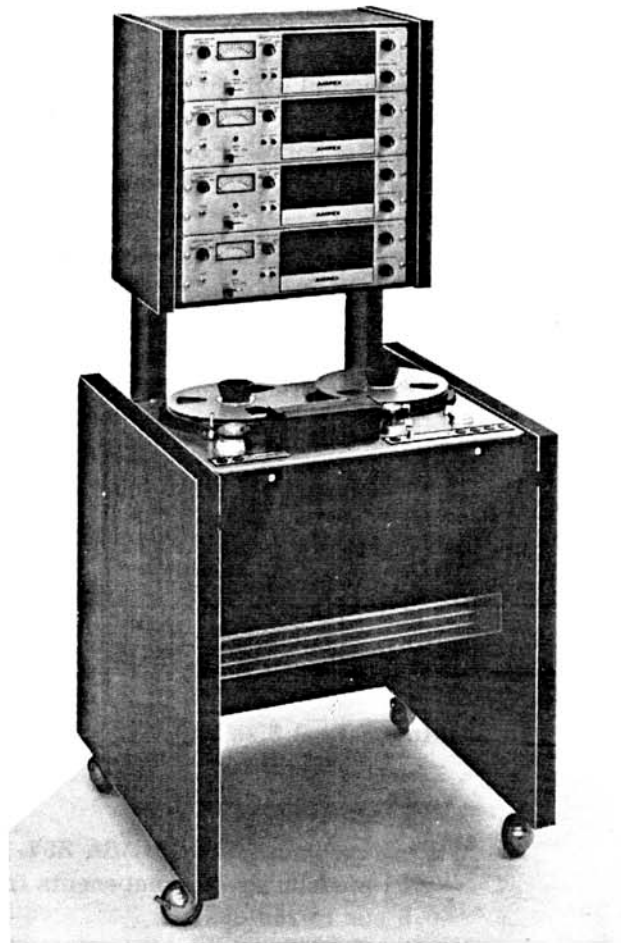

Fig. 1-1 MR-70 in Console



Fig. 1-2 Tape Transport

Indirect drive to the capstan is provided by a hysteresis-synchronous motor. Tape speed is adjustable over a small range by varying the force between the motor and the capstan flywheel. A constant tension holdback system employs a transducer which senses the position of the tape as it leaves the supply reel and varies the holdback torque of the supply motor accordingly. Another feature is the viscous damping of the reel idler flywheel to further improve the flutter and wow characteristics.

A heavy casting, which serves as a mounting base for all components, assures that critical alignment of those components is accurate and long-lasting. Pushbutton control of tape motion, power, and speed selection is provided.

1.4 SPECIFICATIONS

1.4.1 Tape Transport

Tape Width and Channel Configuration

1/4-inch--1 or 2 channels
 1/2-inch--2, 3, or 4 channels
 1-inch--3, 4, 6, or 8 channels

Tape Speeds

2 speeds--
 7-1/2 and 15 ips or 15 and 30 ips

Maximum Reel Size

11-1/2-inch CCIR (CCIR Adaptors available)

Flutter and Wow

Measured according to ASA Z57.1-1954 measuring all components from 0.5 cps to 250 cps.

7½ ips less than 0.08% rms
 15 ips less than 0.05% rms
 30 ips less than 0.05% rms

Start Time

Tape will be within $\pm 0.2\%$ of nominal speed in 0.5 second.

A master bias and erase oscillator, mounted on the tape transport, feeds a bias amplifier in each electronic assembly which in turn routes the 150 kc signal to the record and erase heads.

1.3 ELECTRONIC ASSEMBLY

Each electronic assembly provides the record and reproduce facility for one channel. Modular construction is employed wherever feasible, with the record driver amplifier, reproduce output amplifier, and bias amplifier assembled as plug-in units. Several accessory items--such as a Sel-Sync* amplifier, input transformers, etc.--are also complete modules which simply plug into provided receptacles.

The output may be strapped to feed either a 600 ohm or 150 ohm line at a level of either +8 vu or +4 vu. Record and reproduce level controls can be locked in position to prevent accidental change of settings, and the accidental erasure of a recorded tape can be prevented by placing a record selector switch in the SAFE position.

Nuvistor circuitry provides better reliability and performance than are available with conventional vacuum tubes or germanium transistors. Stable operation is achieved by conservative design, using high feedback, and employing high quality components.

* TM, Ampex Corp.

Timing Error $\pm 0.15\%$ maximum

Fast Modes Continuously variable from 0 to 400 ips.
Rewind time approximately 80 seconds
for 10-1/2 inch reel (2400 feet of tape).

1.4.2 Electronics

Input 20 K unbalanced convertible to 20 K
balanced with optional plug-in bridging
transformer.

Will accept line levels from -20 vu to
+12 vu.

Output Strappable for either 150 or 600 ohms,
balanced or unbalanced, with nominal line
levels of +4 vu or +8 vu.

Equalization Equalization switch accomplished by trans-
port speed selector. Choice of curves at
each speed for NAB, CCIR, and AME (15
ips only) equalization. Adjustments will
accommodate other curves in the 17.5 to
100 microsecond range, either with or
without the 3180 microsecond low frequency
pre-emphasis and post-emphasis.

Overall Frequency Response 15 ips NAB-- ± 1 db 50 to 15,000 cps
 ± 2 db 30 to 20,000 cps

7-1/2 ips NAB-- ± 1 db 50 to 12,000 cps
 ± 2 db 40 to 15,000 cps

30 ips (17.5 --Full track heads
microseconds) ± 1 db 50 to 20,000 cps

--Multi-track heads
 ± 1 db 100 to 20,000 cps
 ± 2 db 50 to 20,000 cps

Signal-to-Noise Ratio

<u>Type of Head</u>	<u>Track Width</u>	15 ips <u>NAB</u>	7½ ips <u>NAB</u>	30 ips <u>(17.5µ Sec.)</u>
1/4-inch Full Track	0.234	70 db	70 db	72 db
1/4-inch Two Track	0.075	65 db	65 db	67 db
1/2-inch Two Track	0.200	69 db	69 db	71 db
1/2-inch Three Track	0.100	66 db	66 db	68 db
1/2-inch Four Track	0.070	65 db	65 db	67 db
1-inch Three Track	0.250	70 db	70 db	72 db
1-inch Four Track	0.180	69 db	69 db	71 db
1-inch Six Track	0.095	66 db	66 db	68 db
1-inch Eight Track	0.070	65 db	65 db	67 db

Signal-To-Noise is measured from peak record level to unweighted noise. Peak record level is defined as the level of a long wavelength signal whose remanent flux is 6 db above that of Ampex operating level (on typical tapes this corresponds to the 3% third harmonic

distortion level). Unweighted noise measured with a filter (see Section 5) and using specified low noise tape biased for maximum sensitivity at a .015 inch wavelength.

Erase	A mid-frequency signal recorded at peak record level will be reduced at least 68 db by the erasing system.
Channel Separation	When a signal is recorded on one track with no signal (bias only) on an adjacent track, the signal-to-crosstalk ratio will be greater than 50 db from 150 to 15,000 cps.
Even-Order Distortion	The second harmonic distortion of a 500 cps signal recorded at peak record level (approximate 3% third harmonic distortion level) will be less than 0.5%.
Electronic Overload Margin	Record Amplifier: Total harmonic distortion less than 1% from 50 to 15,000 cps at a constant record current 25 db above mid-frequency operating level signal. Reproduce Amplifier: Total harmonic distortion less than 1% from 50 to 15,000 cps at tape saturation level (14 db above normal operating level).

1.4.3 General

Power requirement	Strappable for 115 volts or 230 volts. Adjustable by switch for ± 12 volts, providing nominal voltage requirements of 103, 115, 127, 218, 230, or 242 volts. Equipment available for either 50 or 60 cps power frequency.
Power Consumption	
1-Channel equipment	2.5 amperes at 115 volts 1.25 amperes at 230 volts
2-Channel equipment	3.0 amperes at 115 volts 1.5 amperes at 230 volts
3-Channel equipment	3.5 amperes at 115 volts 1.75 amperes at 230 volts
4-Channel equipment	4.0 amperes at 115 volts 2.0 amperes at 230 volts
Dimensions and Weight	
Tape Transport	19 by $24\frac{1}{2}$ by 12 (deep) inches 130 pounds
Electronic Assembly	19 by $5\frac{1}{4}$ by 12 (deep) inches 27 pounds

Console

29 (w) x 29-1/4 (d) x 62-1/2 (h) inches
180 pounds

Magnetic Tape

Performance specifications are based on
the use of M. M. M. Type 201 Magnetic
Tape.

INSTALLATION**2.1 UNPACKING****2.1.1 Console Mounted Equipment**

Console mounted equipment is shipped with all assemblies secured in place on the console, and all connections between assemblies completed. The console lies flat on its back in the shipping package, with the tape transport rotated 90° in the console so that it is in the horizontal position during transit.

Open the shipping container completely, and be sure the casters are screwed completely in (so that the caster stud will not be bent when the equipment is tilted upright). Then place a board in position to block the casters when the console is lifted to the vertical position. Grasp the console at the rear member between the electronic housing and the tape transport (see Fig. 2-1) and tilt the console up and forward so that it comes to rest in the vertical position on the four casters.

Examine the equipment carefully for any sign of external damage that may have occurred during shipment. If any such damage is noted, report it immediately to your Ampex distributor and the transportation company involved.

2.1.2 Unmounted Equipment

Unmounted equipment is shipped with the tape transport and electronic assemblies packed in separate containers. Unpack each case, checking

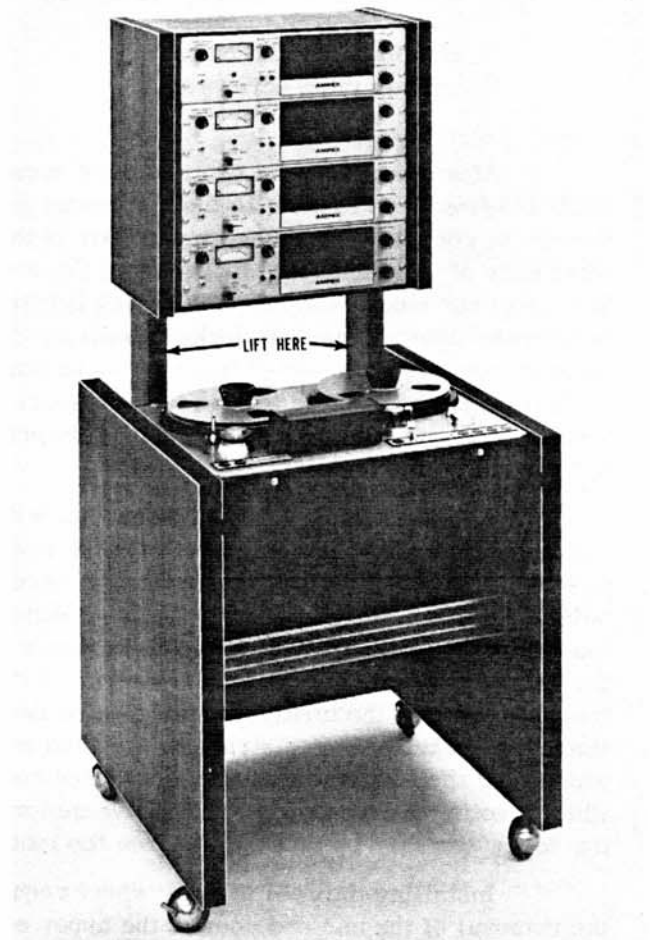

Fig. 2-1 Console Mounted Equipment

for shipping damage. If any has occurred, report it immediately to your Ampex distributor and the transportation company involved.

2.2 PRELIMINARY TO INSTALLATION

2.2.1 Console Mounted Equipment

As previously mentioned, console mounted equipment is shipped with the tape transport rotated 90°. It is secured in this position by two screws through the frame, which mate with two threaded inserts at the lower corners of the transport (as it is shipped). These screws are available from the back of the equipment.

CAUTION

Have someone hold the transport in the vertical position while these two screws are removed. The transport is hinged near the center of gravity, but is secured in the shipping position only by the retaining screws.

After removing the two retaining screws allow the transport to pivot to the horizontal position in the console. Open the hinged door at the front edge of the transport, by pressing the two buttons at the sides, and turn the spring loaded positioning plunger from its locked position. The plunger can then be inserted into one of the holes in the side of the console to hold the transport in position. Close the hinged door, and again press the two buttons to lock it.

The tape transport is shipped with a drive motor locking screw installed and with the reel idler flywheel removed. To gain access to the necessary points, open the hinged cover at the front edge of the transport, pull out the positioning plunger from the hole in the side of the console, and pivot the transport so that the turntables are toward the back. Use care not to put undue strain on the head cables, which feed through a hole in the back of the console, while pivoting the transport. The drive motor locking screw can then be removed to free the motor.

Installing the reel idler flywheel requires the removal of the bar and door at the upper edge of the transport (as the transport is now rotated). This is accomplished by removing the two screws

from the frame at each end of the bar, then opening the hinged cover (by pressing the two buttons at each side of the door) to free the door and bar as a unit. Slip the flywheel over the shaft of the reel idler motor, positioning it so the two set screws are opposite the flat portions of the shaft, and tighten the two set screws. Replace the door and bar assembly, and lock the door by again pressing the two buttons. Now pivot the transport back to its normal position, carefully feeding the head cables into the hole at the back of the console so that they do not interfere with any moving part.

2.2.2 Unmounted Equipment

On unmounted equipment, it is necessary to remove the drive motor locking screw and install the reel idler flywheel. This is accomplished the same as in the console mounted version, except that there is no framework or door that need be removed.

NOTE

If the equipment is to be rack mounted, removing the locking screw and installing the flywheel can be most easily accomplished by waiting until mounting is completed.

2.3 MOUNTING

When the equipment is ordered with the console, all components are mounted at the factory.

Other equipment may be mounted in standard 19-inch racks or in custom cabinets. The major limitations in locating the components are that cables from the magnetic heads must not be lengthened and that adequate ventilation must be provided.

Adhesive backed sponge rubber strips are provided with unmounted equipment. These strips are to be installed at each inner edge of the rack under the electronic assemblies to provide a degree of vibration isolation.

NOTE

If the tape transport is rack mounted, it must be positioned with the supply turntable up and the control pushbutton clusters running vertically

on the left side. The equipment was so designed to allow convenient tape threading from the upper to lower reel.

2.4 INTERCONNECTING COMPONENTS

All components shipped in a console are interconnected at the factory. It is therefore necessary only to connect the signal input and output leads (refer to paragraph 2.5) and the power cable (refer to paragraph 2.6). Should interconnecting become necessary--because of adding electronic assemblies, changing heads, etc.--follow the instructions provided in subsequent paragraphs for equipment shipped unmounted. Route the cables as at the factory, with control and bias lines running from the transport through the right upright (as viewed from the back of the console) to the electronic assemblies, the head (and signal input/output) cables through the left upright.

Equipment shipped from the factory in an unmounted condition must be interconnected after it is secured in the rack or other mounting. Connect the power interconnecting cable (Cat. No. 4050365) from J509 on the tape transport to J112 on each electronic assembly. (Dash numbers following the catalog number of this cable denotes the number of electronics it will feed, thus a -01 is for single channel equipment, -02 for two channel, etc.)

Connect the long bias interconnecting cable (Catalog No. 4050366-01) from J502 on the tape transport to either J104 or J105 on the first electronic assembly. If there is more than one electronic assembly, connect the short bias interconnecting cables (Cat. No. 4050366-02) from J104 or J105 (whichever was not connected to the transport) on the first assembly to J104 or J105 on the second, the same from the second to third, etc. Continue the connections until all bias connectors are jumpered back to the first, which in turn is connected to the tape transport. (J104 and J105 on each assembly are connected in parallel.)

Head cables are captive at the tape transport. The female connectors that terminate erase head cables are for one pin receptacles, those for the record head cables are for two pin, and those for the reproduce head cables are for three pin. Cables are marked to show the head track to which they apply.

Connect erase head cables to J107 on the applicable electronic assemblies, record head cables to J109, and reproduce head cables to J110. (In console mounted equipment electronic assemblies are connected with the top assembly to track 1, the next lower to track 2, etc.)

2.5 CONNECTING SIGNAL LINES

2.5.1 General

Signal input leads are connected to the applicable electronic assemblies at J101, a female receptacle, and output leads are connected at J114, a male receptacle. Standard XL mating connectors for these receptacles are provided with the equipment.

To connect an unbalanced line input, wire the signal leads to pins 2 (ground) and 3, and the shield to pin 1, of the male mating connector provided; then jumper pin 2 to pin 1. With this type input, the jumper plug (supplied) must be inserted in octal socket J102 on the electronic assembly. To connect a balanced line input, wire the signal leads to pins 2 and 3 and the shield to pin 1 (ground). An optional matching or bridging transformer plug-in unit (refer to Section 7) must be inserted in J102. If the equipment is to be used directly with a microphone, without preamplification through a mixer or control console, wire the microphone leads the same as for the balanced line input. An optional microphone preamplifier plug-in unit (refer to Section 7) must be inserted in J102.

NOTE

If a microphone preamplifier is used, resistor R101, across pins 3 and 2 of octal socket J102, should be removed. This resistor is installed to ensure flat response from the optional plug-in transformer units. If the equipment is ordered for exclusive use with a microphone preamplifier, this resistor is removed at the factory.

To obtain an unbalanced line output, wire the signal leads to pins 2 (ground) and 3 of the female mating connector, the shield to pin 1 and jumper pins 1 and 2. For a balanced line output, wire the signal leads to pins 2 and 3 and the shield to pin 1.

Two options are available at the output-- the equipment can feed either a 600 ohm or a 150 ohm line at a level of either +4 vu or +8 vu. If detailed on the purchase order, the equipment will be set at the factory in accordance with customer requirements. Details of the factory set up are included on a packing sheet that accompanies each recorder. If the set up is incorrect for output line impedance or level refer to paragraph 2.9.

2.5.2 Routing Signal Cables-- Console Mounted Equipment

To route the signal cables into the console requires the removal of the back panel of the electronic housing, which is secured by six Phillip head screws, and the snap-on back cover of the transport housing. The input and output cables then enter the hole on the inward side of the left upright that supports the electronic housing. They are routed up this hollow upright and then fan out from the rear of the upright to the applicable electronics assembly. (After entering the upright, they follow the same general path as the head cables, which are also routed through this upright.)

Replace the electronic housing cover, secured by the six screws, but leave the snap-on cover removed to connect the power cable.

2.6 CONNECTING POWER

CAUTION

Straps must be positioned on transformers in the tape transport and all electronic power supplies for either 115 volt or a 230 volt power source. These straps are installed at the factory in accordance with customer requirements as detailed on the purchase order. If there is any question that the equipment is properly strapped for the power voltage available, consult the packing sheet that describes the individual recorder being installed. Strapping instructions are given in paragraph 2.8.

The power cable (Catalog No. 4050368) which is provided, connects from J504 on the tape transport control box to the power source.

In console mounted equipment the snap-on back panel of the transport housing must be removed. Then rotate the transport on its pivot mounting so that the reel turntables are to the front. Ob-long holes are provided in the console cross member behind the transport. Route the power cable through the right hand hole (viewing the console from the rear) to connector J504.

Replace the snap-on back panel.

2.7 LOCATION OF PLUG-IN UNITS

2.7.1 General

Insofar as possible, all plug-in units (including optional accessories) will be inserted in the correct receptacles at the factory. The following discussion is therefore included primarily as a reference if units are removed during maintenance procedures, or if a change--such as replacing an optional input transformer with a microphone pre-amplifier--is required. Details of optional plug-in units installed is shown on the packing sheet.

In the following discussion, the location of standard units (provided with all recorder/reproducers) is described first, then the location of optional accessory units.

2.7.2 Standard Plug-In Units

2.7.2.1 Master Bias Oscillator Module

This unit is located in the tape transport control box, inserted in receptacle J501. One master bias oscillator suffices for the complete system. It is held in position by a quarter-turn fastener. The perforated cover over the transport control box must be removed to gain access to this module.

2.7.2.2 Bias Amplifier Module

One bias amplifier module is required for each electronic channel. The module is inserted in J106 on each electronic assembly. It is secured by a quarter-turn fastener to the electronic chassis. The perforated top cover of the electronics must be removed to gain access to this module.

2.7.2.3 Output Amplifier Modules

Two of these module are required for each electronic channel--one for the record circuit, the other for the reproduce circuit. They are inserted in J103 (record) and J113 (reproduce). Both

are held in position by quarter-turn fasteners. The perforated top cover of the electronic assembly must be removed to gain access to these modules.

2.7.2.4 Jumper Plug

One of these plugs is provided for each electronic channel. It is inserted in J102 when the equipment is used with an unbalanced line input. It is replaced with an input transformer--either matching or bridging--when a balanced line input is employed, or with a microphone preamplifier if the equipment is to be used directly with a microphone. The perforated top cover of the electronic assembly must be removed to gain access to this plug.

2.7.3 Optional Accessory Plug-In Units

2.7.3.1 Sel-Sync* Amplifier Module

This unit provides for sound-on-sound recording. It is inserted in J108 on all electronic channels which will be used for this type of recording. The perforated top cover of the electronic assembly must be removed to gain access to the receptacle.

2.7.3.2 Input Transformer Module

Two types of plug-in input transformers are available. One is balanced bridging with unity gain, the other is balanced matching with 14 db gain (refer to Section 7 for description and catalog numbers). The applicable unit replaces the jumper plug (refer to paragraph 2.7.2.4) in J102 when a balanced line input is employed. The perforated top cover of the electronic assembly must be removed to gain access to J102.

2.7.3.3 Microphone Preamplifier Module

Two microphone preamplifier plug-in units, each designed for low impedance microphones, are available. One provides 40 db gain and will accommodate microphones rated from -50 to -25 dbm (2.4 to 43 millivolts). The other furnishes 60 db gain for microphones rated from -70 to -35 dbm (0.23 to 13.7 millivolts). Refer to Section 7 for descriptions and catalog numbers. The applicable unit replaces the jumper plug (refer to paragraph 2.7.2.4) in J102 when recording directly from a microphone. The perforated top cover of the electronics assembly must be removed to gain access to J102.

NOTE

When a microphone pre-amplifier is used, resistor R101 wired from pin 3 to pin 2 on octal socket J102 should be removed.

2.8 STRAPPING FOR 115 OR 230 VOLT POWER SOURCE

2.8.1 General

Power transformers in the tape transport and each electronic assembly must be properly strapped for operation with a 115 volt power source or a 230 volt power source. If detailed on the purchase order, this strapping will be accomplished at the factory in accordance with customer requirements. The factory strapping will be indicated on the packing sheet which accompanies each recorder; if incorrect for the power source available, the strapping must be changed.

2.8.2 Tape Transport

Power source strapping for the tape transport is accomplished on the terminal board of the transport control box. For 115 volt operation terminal 56 is jumpered to 57; and terminal 54 is jumpered to 55. For 230 volt operation, only one jumper is used--from terminal 54 to 56. The perforated cover on the transport control box must be removed to gain access to the terminals.

In addition to the strapping, a switch is provided on the control box to compensate for an excessively low or high voltage power source. This switch has three positions-- +12, NOM, and -12. The switch should be positioned so as to make the effective voltage as close as possible to the nominal 115 or 230 volts--for example, if the normal power line voltage is 117 (or 234) volts the switch should be in the NOM position, if it is 125 (or 240) volts, the switch should be in the +12 position, if it is 108 (or 223) volts, the switch should be in the -12 position.

NOTE

As described, strapping can be employed to allow the equipment to operate from power sources of either 115 volts or 230 volts (both nominal). This strapping, however, has no

* TM, Ampex Corporation

effect on power line frequency, and different speed determining components are required for operation with 60 cps and 50 cps power.

2.8.3 Electronic Assemblies

Power transformers on each electronic assembly must be properly strapped for 115 or 230 volt operation. This strapping is accomplished at the terminal board beneath the electronic chassis. For 115 volt operation, terminal 56 is jumpered to 57, and terminal 58 is jumpered to 59. Only one jumper is employed for 230 volt operation, from terminal 57 to 58. The perforated bottom cover on the electronics assembly must be removed to gain access to the terminals.

2.9 OUTPUT LINE SELECTION

The equipment can be set up to drive either a 600 ohm or 150 ohm line at a level of either +4 vu or +8 vu. If detailed on the purchase order, the recorder will be set at the factory in accordance with customer requirements.

A 600 ohm output line requires that resistor R179 be 560 ohms. For a 150 ohm line this resistor is changed to 150 ohms. This can be accomplished at the back of the electronic assembly. No change in calibration is required, because the vu meter is connected to a separate winding on the output transformer.

Line output level is changed simply by changing the calibration of the vu meter, which is in turn determined by straps on the terminal board. For a +8 vu level, terminal 7 is jumpered to 6; for a +4 vu level, this strap is changed so that terminal 5 is jumpered to 6.

NOTE

If the output line level is changed, the reproduce level control setting must be changed and the record level must be recalibrated (see Section 5).

2.10 CONNECTING ACCESSORY EQUIPMENT OR INSTALLING JUMPER PLUGS

2.10.1 General

Several receptacles are provided where accessory equipment can be easily connected. If

that equipment is not used, jumper plugs must be inserted in those receptacles.

2.10.2 Motor Drive Amplifier

A precision drive amplifier for the capstan motor can be connected at J506 on the transport control box (see schematic diagram, Section 8). For 115 volt operation, the a-c line to the amplifier is taken at pins 1 and 4, and the precision frequency a-c power for the capstan motor is delivered to pins 2 and 5. For 230 volt operation, the a-c line to the amplifier must be delivered directly, not taken from J506. The precision frequency a-c power to the capstan motor is again connected to pins 2 and 5.

CAUTION

Do not attempt to supply the motor drive amplifier power from J506 when operating with a 230 volt power source. Power transformer T501 is not rated to supply this power with the 230 volt strapping.

If a motor drive amplifier is not used, a jumper plug (P506) must be inserted in J506 or the capstan motor will not operate.

2.10.3 Transport Remote Control

Remote control connections for tape transport operation are provided at J507 on the transport control box. A transport remote control unit is available from Ampex as an optional accessory. A schematic diagram of this unit is shown in Section 8.

If remote control of the transport is not employed, a jumper plug (P507) must be inserted in J507 or the transport will not operate.

2.10.4 Edit Foot Pedal Switch

It is recommended that an edit foot pedal be connected to J508 on the transport control box. This is simply a normally open foot pedal switch, connected across pins 1 and 2 of this receptacle. No jumper plug is necessary if the foot switch is not used.

2.10.5 Electronics Remote Control

Connection facilities for remote control of the electronic channels--from a control console,

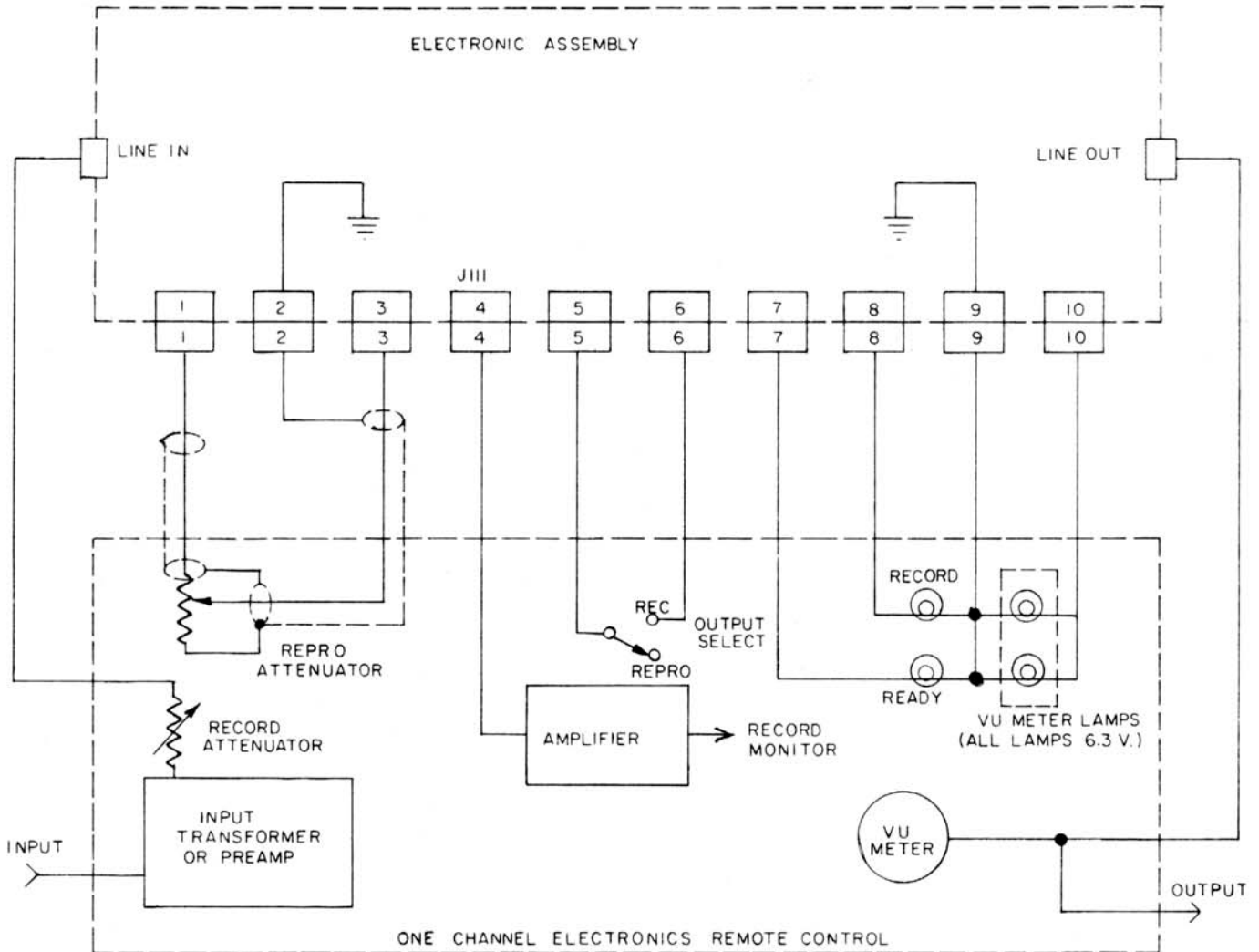

Fig. 2-2. Suggested Electronic Remote Control

mixer, etc--are provided at J111. Suggested connections to this receptacle and other connectors, for one channel of electronics, are shown in Fig. 2-2.

If electronic remote control is not used, a jumper plug (P111)--which contains a built-in 14 db reproduce attenuator pad--must be inserted in J111 or there will be no reproduce function.

2.11 ADJUSTING REEL TURNTABLE HEIGHT

The reel turntable heights can be set to allow the use of metal reels only, plastic reels only, or to a compromise height that allows the use of either metal or plastic reels. The equipment is shipped with these heights set for metal reels only,

but they can be easily changed to either of the other two positions.

If the equipment is to be used with plastic reels exclusively, remove the turntable (by removing the three large Allen head screws), and remove the thick shim immediately underneath the turntable. If operation is to be with both metal or plastic reels, the thick shim installed at the factory is changed to a think shim (provided with the equipment).

Thus, with metal reels use the thick shim under the turntable, with plastic reels use no shim, and for a compromise between metal and plastic use the thin shim.

OPERATING INSTRUCTIONS

3.1 GENERAL INSTRUCTIONS

3.1.1 System Setup and Adjustment

In the instructions that follow, it is assumed that the basic electronic setup and adjustment procedures, considered as maintenance functions, have been followed. These procedures are described in Section 5.

3.1.2 Transport Position

When the equipment is mounted in the optional Ampex console, the position of the transport can be changed in three increments from fully horizontal to slanting toward the operator at an approximate 15° angle. To change this position to that which is most convenient, open the hinged cover directly below the forward edge of the transport by pressing the two buttons. Holding the transport, pull out the spring-loaded positioning shaft at the right side of the console and pivot the front of the transport up or down so that the positioning shaft snaps in to secure the transport in the new position. Close the cover, and latch it by again pressing the two buttons.

3.1.3 Tape Reels

The height of the reel turntables can be adjusted (see Section 2) to accommodate metal reels only, plastic reels only, or to a compromise height where either metal or plastic reels may be used. Therefore, only the type of reel applicable to the particular equipment should be used.

Plastic reels (EIA hubs) fit closely over the turntable shafts and mate with the drive hub at the base of the shaft. When these reels are used in the vertical position (rack mounted equipment) they must be secured with hold down knobs (Ampex Catalog No. 4100137-10).

Metal reels with NAB hubs require the use of editing knobs (Ampex Catalog No. 4030145-10) when used in the horizontal position (console mounted equipment) or hold down knobs (Ampex Catalog No. 4040492-10) in the vertical position.

Use of reels with CCIR hubs, requires a different drive hub at the base of the turntable shaft. These drive hubs are very easily changed, being secured to the turntable by three Allen head screws, or adaptors can be purchased which mate with the EIA drive hub. All equipment is shipped for NAB-EIA hub use.

The CCIR 11-1/2-inch reel is the largest which can be used, while the EIA 7-inch reel is the smallest. Because of the constant tape tension design, any reel size between these two extremes may be used without having to employ switching to compensate for tension changes. Note however that the EIA tape wrap hub of 2-1/4 inches diameter is the smallest that should be used.

3.1.4 Monitoring

Monitoring during the record, reproduce, or editing modes can be accomplished with headsets plugged into the PHONES jack(s) on the electronic assemblies.

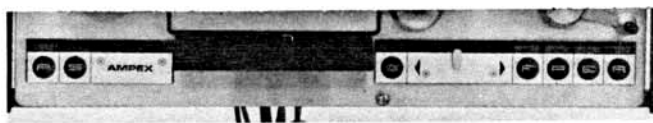

Fig. 3-1. Tape Transport Controls

3.2 CONTROLS AND INDICATORS

3.2.1 Tape Transport

Tape transport operation is controlled by seven pushbuttons and a fastwinding slider, all located along the forward edge of the transport (see Figure 3-1) as it mounts in the optional console. In the following descriptions the controls are listed from left to right as they are located on the transport.

Power pushbutton: This pushbutton controls the application of a-c power to the complete equipment. It is a push on-push off control; the POWER INDICATOR immediately above the pushbutton is illuminated when power is applied.

Speed pushbutton: Selects tape speed by connecting power to the high speed or low speed winding of the capstan motor, and controls the equalization relay in the electronics assembly. The tape speed selected will be shown by the indicator immediately above the pushbutton, which is a push-push control.

Stop pushbutton: Stops tape motion in all modes of operation, and removes electronics from record mode when recording is completed. The STOP indicator immediately above the pushbutton is illuminated when the equipment is in the stop mode and tape is properly threaded.

Fastwinding slider: Determines the direction and speed of tape motion when the equipment is in fast mode.

Fast pushbutton: Places equipment in the fastwinding mode. Direction and speed of tape motion is determined by the position of the fastwinding slider control. The FAST indicator, immediately above the pushbutton, is illuminated when the equipment is in the fast mode. The slider can be moved from a fast forward to a fast rewind position or vice versa; tape motion will slow to a stop and then reverse direction.

Play pushbutton: Starts equipment in the playback mode. The PLAY indicator immediately above the pushbutton is illuminated when the equipment is in the play mode.

Edit pushbutton: Places the equipment in the edit mode. The EDIT indicator immediately above the pushbutton is illuminated when the equipment is in this mode. The equipment can be placed in the stop-edit mode (where mechanical brakes are released, light hysteresis braking applied, the head gate closed, and reels may be manually turned), the play-edit mode (where operation is similar to playback but the takeup motor does not reel in tape-- which spills off the right side of the transport), or the fast-edit mode (where the head gate is closed and the recording can be monitored in the fastwinding modes).

Record pushbutton: Starts equipment in the record mode. The RECORD indicator immediately above the pushbutton is illuminated in this mode. The RECORD SELECTOR switch(es) on the electronic assemblies must be in the READY TO RECORD position or this pushbutton will not lock in the record mode.

3.2.2 Electronic Assembly (see Figure 3-2)

OUTPUT SELECTOR: This is a rotary control with three positions--REMOTE SELECT, REPRODUCE, and INPUT. In the remote select position, selection of the other two functions is transferred to auxiliary switching which can be installed with the optional remote control. In the reproduce position, the signal recorded on the tape is delivered to the output circuit for monitoring; it can be placed in this position while recording to monitor the record function, and must be in this position for playback. In the input position, the input signal can be monitored while recording, or record level can be set before starting tape in motion. While recording, the switch can be moved back and forth between reproduce and input to provide an A-B comparison of the actual program and the recording.



Fig. 3-2. Electronic Assembly Controls

VU meter: Indicates level of signal, bias, or erase, as selected by the meter switch.

METER switch: This is a three position switch which selects the signal to the v-u meter. Selections are for OUTPUT, BIAS, and ERASE. During operation this switch is placed in the output position where the meter will indicate either record or playback level (determined by the position of the OUTPUT SELECTOR switch). In the bias and erase positions, the meter will indicate bias or erase levels, normally checked and calibrated during maintenance procedures.

RECORD SELECTOR: This is another three position switch, selecting SYNC REPRO, SAFE, or READY TO RECORD. The sync repro position is used when recording sound-on-sound, using the optional sync amplifier. In the safe position, the record mode is locked out on that channel. In the ready to record position the channel can be placed in the record mode by pressing the record pushbutton on the tape transport. A READY indicator is illuminated when the switch is in the ready position, and a RECORD indicator shows that the channel has been placed in the record mode.

RECORD LEVEL potentiometer: This control adjusts the level at which a program is recorded. The level is indicated on the vu meter when the METER switch is in the OUTPUT position and the OUTPUT SELECTOR switch is in the INPUT position. Level can thus be set before tape is started in motion. Once set, the control can be locked in the proper position by rotating the locking ring at the base of the knob.

REPRODUCE LEVEL potentiometer: This control adjusts the level of the reproduce (playback) signal, which is set by using the Operating Level section of the applicable Ampex Standard Test Tape. The reproduce level is indicated on the vu meter when the METER switch is in the OUTPUT position and the OUTPUT SELECTOR switch is in the REPRODUCE position. Like the record level control, it can be locked in the proper position.

3.3 TAPE THREADING

The tape threading path is shown in Figure 3-3. Thread the tape through this path from the supply to the takeup reel, and anchor it to the takeup reel hub. Rotate the takeup reel until the supply reel starts to turn, indicating that tape slack is removed.



Fig. 3-3. Tape Threading Path

Mechanical brakes can be released during tape threading by putting the equipment in the stop-edit mode. This is accomplished by applying power to the equipment, and opening the head gate full open. If the recommended foot pedal edit switch is used, simply press that switch closed. If not, move the takeup tension arm up from its rest position until the STOP indicator is illuminated, then press the EDIT pushbutton. (The takeup tension arm can be released and the equipment will remain in the stop-edit mode.) Tape threading can thus be accomplished working against only the relatively light hysteresis braking applied in stop-edit. After threading is completed, release the foot pedal switch (or press the STOP pushbutton) to drop out the edit mode.

3.4 RECORDING

3.4.1 Setting Record Level

The record level can be set before the actual recording session starts. With power applied to the equipment, turn the OUTPUT SELECTOR switch on the electronics assembly (or assemblies) involved to the INPUT position, and the METER switch(es) to the OUTPUT position. Unlock the RECORD LEVEL control by turning the LOCK ring, at the base of the control, counterclockwise. The operator can then use a rehearsal run or test tone to adjust the RECORD LEVEL control so that most program peaks result in the vu meter indicator swinging to 0 on the meter dial, with maximum peaks to +2 or +3 on the meter. Lock the RECORD LEVEL control in the correct setting by rotating the knurled LOCK ring.

3.4.2 Setting Other Controls

At the electronic assembly for each channel that is to be recorded, place the RECORD SELECTOR control in the READY TO RECORD position. If certain channels are not to be recorded place the switch on those electronics in the SAFE position. An amber READY indicator will illuminate on those channels that will be recorded when the record button is pressed. Select the tape speed at which the recording is to be made by using the Speed pushbutton on the tape transport.

3.4.3 Actuating Record Mode

Thread tape on the equipment. Note that the standard erase head assembly erases only the tracks that are being recorded (this provides utmost flexibility for the recording industry). However, if the tape was previously recorded on a full track recorder complete erasure cannot be attained by the erase head (a strip of the previous recording will be left between each track) and crosstalk from the previous recording may be evident when the tape is played back. Such tapes should therefore be bulk erased before recording them on this equipment.

With controls set as described in paragraphs 3.4.1 and 3.4.2, all that is necessary to actuate the record mode is to press the Record pushbutton. Any signal then applied to the input will be recorded through those channels whose electronics were in the READY TO RECORD condition (the READY indicators on those electronics will be extinguished, and the RECORD indicators will be illuminated). At the tape transport, the RECORD indicator, immediately above the pushbutton, will be illuminated.

3.4.4 Operation While Recording

While the recording run is in process, the operator can make an A-B comparison between the actual program as it is delivered to the input of each channel and the recording on the tape. This is accomplished by switching the OUTPUT selector on the applicable electronic assembly between the INPUT (actual program) and REPRODUCE (playback of recording on tape) as desired.

When the recording is completed, press the Stop pushbutton to remove the equipment from the record mode. It is recommended that the RECORD SELECTOR controls on all electronic as-

semblies be left in the SAFE positions except when a recording run is imminent (this will prevent any pre-recorded tape from being erased accidentally).

3.5 REPRODUCING (PLAYBACK)

3.5.1 Setting Controls

At the electronics assemblies for the channels to be reproduced, place the OUTPUT SELECTOR control in the REPRODUCE position (it must remain in this position to achieve any playback output). The RECORD SELECTOR switches on all electronic assemblies may be placed in the SAFE position to prevent accidental erasure of the pre-recorded tape. Select the tape speed to be the same as the recording speed by using the Speed pushbutton on the tape transport.

3.5.2 Entering Reproduce Mode

Thread the pre-recorded tape on the equipment. With power applied, it is necessary only to press the Play pushbutton on the tape transport to place the equipment in the reproduce mode.

Normally, the REPRODUCE LEVEL control will be locked in the position that results in a peak program indication of 0 on the vu meter when the operating level section of the applicable standard test tape is played back. Zero indication on the vu meter corresponds to a line output of either +4 vu or +8 vu (depending on internal strapping of the equipment--see Section 2) into a 150 or 600 ohm line impedance. If necessary to achieve this level, or if a different level is desired, unlock the REPRODUCE LEVEL control and adjust it as required. Then re-lock the control.

Press the Stop pushbutton to remove the equipment from the reproduce mode.

3.6 USE OF FASTWINDING MODE

With tape threaded and power applied, tape can be shuttled from one reel to the other by using the fast modes. Speed of this shuttling can be varied, by using the slider control between the Stop and Fast pushbuttons, from barely moving up to approximately 400 ips. The fast mode is entered, with tape at a standstill or in either the play or record modes, by pressing the Fast pushbutton. The position of the slider then determines the direction and speed of tape motion. Press the Stop pushbutton to remove the equipment from the fast-winding mode.

CAUTION

When using fastwinding, do not press the Stop and then the Play or Record pushbuttons in such rapid sequence that tape motion cannot stop before the capstan idler clamps the tape to the capstan. If motion does not stop first, the tape will probably be broken or stretched.

3.7 EDITING

3.7.1 General

There are three edit modes provided on this equipment--stop-edit, play-edit, and fast-edit. In any of these modes, tape will remain in contact with the heads and the head gate can be opened to provide full access to the head assembly.

For most convenience, it is recommended that the optional edit foot pedal be used for controlling the edit function. The edit mode can then be applied and removed without interrupting operation by pressing the Stop pushbutton.

3.7.2 Stop-Edit Mode

In this mode, the tape is in contact with the heads and the mechanical brakes on both reel motors are released. The reels can then be manually rotated, against relatively light hysteresis braking, for precise editing and cueing. (As previously described, this mode can also be used to make tape threading easier.)

To enter the mode with tape threaded and power applied (STOP indicator illuminated), simply close the foot pedal switch or press the Edit pushbutton on the transport. The EDIT indicator will be illuminated in addition to the STOP indicator, and the editing or cueing process can proceed. Release the foot pedal or press the Stop pushbutton to remove the equipment from the stop-edit mode. The mechanical brakes will then be applied and the tape will be held firmly in position.

3.7.3 Play Edit Mode

In this mode, tape is in contact with the heads and the capstan drives the tape at the selected speed. However, the takeup turntable will not rotate, and tape will spill off the right side of the recorder. To enter the mode with tape threaded,

press the Play pushbutton and close the foot pedal switch simultaneously (or press the Edit pushbutton simultaneously). Both indicators will be illuminated.

The mode can also be entered with tape not anchored to the takeup reel in instances where the leader is to be discarded. In that case, thread the tape in its normal path past the capstan and idler, and manually move the takeup tension arm from its rest position until the STOP indicator is illuminated. Press the Play pushbutton and close the foot pedal switch or press the Edit pushbutton. The PLAY and EDIT indicators will be illuminated and the takeup tension arm can then be released.

Release the foot pedal or press the Stop pushbutton to remove the equipment from the play-edit mode and stop tape motion.

3.7.4 Fast Edit Mode

This mode is exactly the same as the fast-winding mode (see paragraph 3.6) with the exception that tape is in contact with the heads and can be monitored. Tape speed and direction is controlled by the slider the same as in fastwinding.

To enter the mode, tape must be threaded and power applied. Press the Fast pushbutton and close the foot pedal switch or press the Edit pushbutton (the sequence of these operations does not matter in this instance). Control tape speed and direction with the slider.

Release the foot pedal or press the Stop pushbutton to remove the equipment from the fast-edit mode. (To stop tape motion when using the foot pedal, press the Stop pushbutton.)

3.8 OPERATING FROM OPTIONAL REMOTE CONTROL UNIT

With the exception that no edit function is available, the optional tape transport remote control unit provides essentially the same control as do the pushbuttons on the tape transport. However certain procedures must be accomplished at the equipment proper before attempting to operate from the remote control.

1. At the tape transport, power must be applied, tape threaded, and tape speed selected.
2. If auxiliary switching for electronic remote control is not employed (refer to Section 2) all electronic controls must be set up as described

under Recording and Reproducing (paragraphs 3.4 and 3.5). In any case, record and/or reproduce levels must be correctly calibrated, and if a record run is to be made the applicable electronics must be placed in the READY TO RECORD condition.

NOTE

Operation from the remote control should not be attempted unless the STOP indicator on that unit is illuminated. If no indicator is illuminated it might indicate that someone was manually cueing the tape in the stop-edit mode, and sudden actuation of the reel motors (possible in fastwinding from the remote control) could result in spoiling the cue. If any indicator other than stop is illuminated it means that the equipment is being operated from the equipment proper, and any interruption could spoil a record or reproduce run.

With the procedures at the equipment proper completed, the STOP indicator on the remote control will be illuminated, acting as a "ready" indicator. The PLAY and RECORD pushbuttons then operate exactly as those at the tape transport to place the equipment in the reproduce or record modes. Control of electronics (levels, monitoring, etc.) is dependent on what auxiliary switching is available.

No variable speed is provided in the fastwinding control from the remote unit. When the FAST FWD pushbutton is pressed tape moves at high speed from the supply to the takeup reel; when the REWIND pushbutton is pressed tape moves at high speed from the takeup to the supply reel. (If both are pressed simultaneously, the equipment will enter the rewind mode.) In either fastwinding mode, the CANCEL TAPE LIFT pushbutton defeats the tape lift solenoid so that the tape can be monitored through a remote speaker.

The STOP pushbutton on the remote control is in series with the STOP pushbutton on the

transport, while the PLAY and RECORD pushbuttons are in parallel with their counterparts on the transport. Therefore, the equipment can be stopped or placed in play or record from either location, with neither assuming absolute control. The equipment can also be placed in a fastwinding mode from either location, but if it is being used with variable speed from the transport and either fastwinding pushbutton on the remote control is pressed, the direction and speed of tape travel cannot be controlled at the transport without first re-establishing control by pressing the STOP pushbutton.

3.9 RECORDING SOUND-ON-SOUND

3.9.1 General

This type of recording requires the use of the optional Sel Sync* preamplifiers, which plug into octal socket J108 on the electronic chassis. A discussion of the development of this recording technique is given in Section 5.

3.9.2 Procedure

At the electronic assembly corresponding to the first track(s) to be recorded, place the RECORD SELECTOR switch in the READY TO RECORD position. Place this switch on all other electronic assemblies in the SAFE position. Then follow normal procedures to record the first track(s).

After recording the first run, rewind the tape to the beginning of the recording. Place the RECORD SELECTOR switch(es) for the channel(s) already recorded in the SYNC REPRO position. Place this switch on the next channel to be recorded in the READY TO RECORD position. Have the performer monitor the output of the channel(s) previously recorded by using headphones. Place the equipment in the record mode, the performer will hear the previous recording, and can sing or play in unison with that recording.

Proceed in this manner until all parts are recorded, being certain to switch previously recorded channels out of the READY TO RECORD condition before recording subsequent runs. (All previously recorded channels or only selected channels can be in SYNC REPRO to be monitored while a new run is made.)

* TM, Ampex Corporation

TRANSPORT MAINTENANCE

4.1 ROUTINE MAINTENANCE

4.1.1 General

Procedures described in this paragraph include cleaning, lubricating, and checkout of the tape transport. Test equipment and supplies required are as follows:

Denatured Alcohol.

Ampex Lubricating Oil,
No. 01-0825 or Standard
OC-11 oil.

Spring Scale, 0-16 ounce.

Length of Cord or String,
Approximately 30 inches long.

Special Tool (must be fabricated,
see Fig. 4-1).

Spring Scale, 0-32 ounce.

Spring Scale, 0-10 pound.

Strobosticker (provided) or tape
strobe (Dubbings Electronics,
Model AA or equivalent).

Flutter meter

4.1.2 Cleaning

Cleaning and demagnetizing the heads and other components in the tape threading path is described in Section 6. It is of utmost importance that these procedures be followed on a regularly scheduled basis.

Periodically clean the components at the back of the transport, using a clean cloth or small brush moistened with denatured alcohol. A vacuum cleaner can also be used, but do not use the blower action of such a device, or dust and dirt might be forced into bearings or other critical areas.

4.1.3 Lubricating

Three components on the tape transport--the capstan, capstan idler, and drive motor--require lubrication. The recommended lubricant is Ampex Lubricating Oil, Catalog No. 01-0825, or Standard OC-11 oil. Lubrication is required each three months, or after each 1,000 hours of operation (whichever occurs first).

To oil the capstan, remove the set screw in the cone-shaped dust cap which surrounds the capstan. Then lightly press the capstan idler toward the takeup turntable and remove the dust cap.

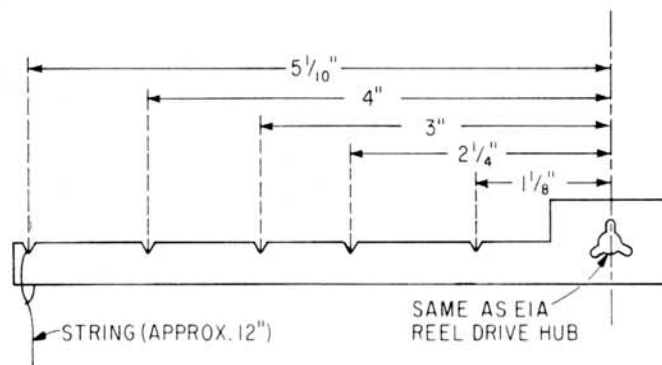

Fig. 4-1. Special Tool for Checkout

Remove the felt washer then exposed, and fill the oil hole in the capstan upper bearing with the oil. Wipe off any excess oil, and reinstall the felt washer and dust cap.

The capstan idler is lubricated by gently prying the dust cap from the idler hub, exposing a felt washer. Put not more than three drops of oil on the felt washer, and reinstall the dust cap.

Oil cups are provided at each end of the drive motor. Place not more than four drops of oil in each cup at the same time that the capstan and idler are lubricated.

4.1.4 Checking Holdback Tape Tension

Holdback tape tension in the play or record modes is held relatively constant by the action of the tension control arm on the torque control transducer. If the transducer is properly adjusted and working correctly, the tension will be within tolerances from one end of the reel to the other.

A quick check of correct action consists of determining holdback torque at the hub of an empty reel.

Step 1: Place an empty reel on the supply turntable. The minimum reel hub diameter that can be used is the EIA 2-1/4 inch; maximum hub diameter is unimportant.

Step 2: Use pressure sensitive tape to hold the takeup tension arm in the actuated position (so the safety switch is released).

Step 3: Apply power to the equipment.

Step 4: Wind the length of cord, loop end out, counterclockwise on the reel hub, leaving approximately 12 inches at the free end.

Step 5: Insert the hook on the 0-16 ounce spring scale through the loop in the cord. The cord will leave the reel on the left side; pass it to the left of the tension control arm, and pull the cord taut just touching the left of the reel idler. This will move the tension control arm to the right, in the same position it would be in if the cord were properly threaded magnetic tape (see Fig. 4-2).

Step 6: Hold the scale stationary and press the PLAY pushbutton.

Step 7: Tap lightly on the reel, to ensure a correct reading, and note the indication on the scale. It should be:



Fig. 4-2. *Checking Holdback Tension*

1/4-inch tape equipment	2-1/2 - 3-1/2 oz.
1/2-inch tape equipment	5-1/2 - 6-1/2 oz.
1-inch tape equipment	10-1/2 - 11-1/2 oz.

Press the STOP pushbutton to remove power from the turntable.

A more comprehensive test can be made using the special tool shown in Figure 4-1.

Step 1: Place the arm of the tool over the turntable spindle, mating it with the EIA drive hub. Position it at 9 o'clock on the turntable.

Step 2: Use pressure sensitive tape to hold the takeup tension arm in the actuated position (so the safety switch is released). Apply power to the equipment.

Step 3: Start with the cord at the outer notch on the tool, holding it taut with the 0-16 ounce spring scale to the left of the tension control arm and just touching the left side of the supply idler

(as though it were tape, leaving the supply reel at 9 o'clock and threaded past the idler).

Step 4: Hold the scale stationary and press the PLAY pushbutton.

Step 5: Keep the tool arm at 9 o'clock and tap the turntable lightly to ensure a correct reading. The indication should be the same as in Step 7 of the quick check procedure.

Step 6: Repeat Steps 4 and 5, progressively moving the cord to each notch, toward the center of the reel. Tension should remain within tolerance from the outer to inner notches.

Adjustment of the mechohm is described in paragraph 4.2.

4.1.5 Checking Takeup Tape Tension

Tensions are given both for a direct reading on a standard NAB reel hub and in ounce-inches so that a torque wrench or another type of reel can be used. If using a reel other than NAB, multiply the scale reading by the radius of the reel hub to determine the ounce-inch torque. Adjustment is described in paragraph 4.2.

Step 1: Place an empty reel on the take-up turntable.

Step 2: Use a piece of pressure sensitive tape to hold the takeup tension arm in the actuated position (so the safety switch is released).

Step 3: Apply power to the equipment.

Step 4: Wind the cord, loop end out clockwise on the reel hub.

Step 5: Place the hook on the 0-16 ounce spring scale through the loop in the cord. Hold the scale stationary and press the PLAY pushbutton. A power boost is applied to the takeup motor for approximately 1/2 second; disregard this momentary high reading.

Step 6: Tap lightly on the reel, to ensure a correct reading, and note the indication on the scale. It should be:

	<u>Direct Reading NAB Hub</u>	<u>Ounce- Inches</u>
1/4 inch tape equipment	2 - 4 oz.	$4\frac{1}{2}$ - 9
1/2 inch tape equipment	5 - 7 oz.	$11\frac{1}{4}$ - $15\frac{3}{4}$
1 inch	10 - 12 oz.	$22\frac{1}{2}$ - 27

4.1.6 Checking Brake Force

The braking force on the trailing turntable (supplying tape) is always greater than that on the leading turntable (reeling in tape). This allows tape tension to be maintained during the stopping process. The force must therefore be measured in each direction of reel rotation. Scale indications are again given in both direct readings taken on an NAB reel, and in ounce-inches. No power is applied during the checking procedure.

Step 1: Place an empty NAB reel on the supply turntable.

Step 2: Leaving the loop at the free end, wrap the cord around the reel hub in a counterclockwise direction.

Step 3: Place the hook on the 0-32 ounce spring scale through the loop on the end of the cord. Hold the scale so that the cord does not touch either reel flange, and pull the scale so that the reel turns counterclockwise. Take the reading when the scale is in slow, steady, motion (the force required to overcome the initial static friction will produce a high, erroneous, indication). The scale should indicate:

	<u>Direct Reading NAB Hub</u>	<u>Ounce- Inches</u>
1/4 inch tape equipment	15 - 16 oz.	$33\frac{3}{4}$ - 36
1/2 inch tape equipment	19 - 20 oz.	$42\frac{3}{4}$ - 45
1-inch tape equipment	22 - 24 oz.	$49\frac{1}{2}$ - 54

Step 4: Wind the cord on the reel hub in a clockwise direction. Repeat Step 3 (the reel will rotate clockwise). The indication should be:

1/4 inch tape equipment:	50% of the reading obtained in Step 3 (± 1 ounce or $\pm 2-1/2$ ounce-inches).
1/2 inch tape equipment:	40% of the reading obtained in Step 3 (± 1 ounce or $\pm 2-1/4$ ounce-inches).
1-inch tape equipment:	33-1/3% of the reading obtained in Step 3 (± 1 ounce or $\pm 2-1/4$ ounce-inches).

Step 5: Repeat the entire procedure at the takeup turntable. The scale indications should

be the same as quoted in Steps 3 and 4, but the high reading will be obtained when the takeup is rotated clockwise, the low reading when it is rotated counterclockwise.

If any discrepancies are noted, refer to paragraph 4.2 for adjustment procedures.

4.1.7 Checking Capstan Idler Force

With power off, the clearance between the capstan shaft and the rubber tire of the capstan idler should be 1/2-inch ($\pm 1/32$ inch). The force of the idler against the capstan is then measured as follows:

Step 1: Use pressure sensitive tape to hold the takeup tension arm in the actuated position (so the safety switch is released).

Step 2: Apply power to the equipment.

Step 3: Loop a piece of cord around the capstan idler shaft (the shaft around which the rubber tired idler rotates).

Step 4: Place the hook of the 0-10 lb spring scale through the loop of cord.

Step 5: Press the PLAY pushbutton. The idler will move to contact the capstan, and both will rotate.

Step 6: Pull the scale at an angle of 90° to the capstan idler arm. The scale indication just as the idler loses contact with the capstan (the idler will stop rotating) should be:

1/4 inch tape equipment	5 pounds minimum
1/2 inch tape equipment	7 pounds minimum
1-inch tape equipment	7 pounds minimum

Refer to paragraph 4.2 for the adjustment procedure if any discrepancy is noted.

4.1.8 Checking Takeup Tension Arm

The takeup tension arm should actuate the safety switch when the lower edge of the arm is parallel (within $\pm 5^\circ$) with the top edge of the control cluster. This can be checked by applying power to the equipment with no tape threaded. Manually rotate the takeup tension arm upward from its rest position until the STOP indicator is illuminated. Then slowly allow the arm to move back toward its rest position. The STOP indicator should be extinguished when the arm is in the correct position

as described above. If any adjustment is required, refer to paragraph 4.2.

4.1.9 Checking Tape Speed

Tape speed is adjusted at the factory by counting the output pulses from an idler-driven tachometer, with the pulley held against the moving tape so that it is driven by the tape. Such devices are rarely found in the field, and other procedures can be used for checking speed.

One way to determine that tape speed is correct is to use the capstan strobosticker provided. Place the strobosticker on the end of the capstan shaft, thread tape, and place the equipment in the play mode. View the rotating strobo under a 60 or 50 cps light (as applicable). If the capstan speed is exactly correct the spokes will appear stationary, if not they will drift clockwise (speed fast) or counterclockwise (speed slow). Percentage of deviation can be determined by counting the number of spokes which appear to pass a fixed point in a given time. The tape speed error is 0.1% for each seven spokes that pass the fixed point in one minute--thus as many as ten spokes could pass and the tape speed would still be within specifications. (When measuring speed on 50 cycle equipment the error is 0.1% for each six spokes that pass the fixed point in one minute.)

Another (more accurate) method of checking tape speed is to use a tape strobe, such as the one manufactured by Dubbings Electronics. The strobe is placed against the tape, moving in the play mode, so that it is driven by the tape. Using this device, it is important to understand that variations in tape tension occur through the tape threading path--caused by friction between the moving tape and idlers, guides, heads, etc. Therefore, it is possible to obtain different indications at different points in the tape threading path. To obtain the most accurate results, remove the head cover and contact the tape with the strobodisc between the head assembly and the capstan. Usually this degree of accuracy is required only when adjusting tape speed (refer to paragraph 4.2) and a quite dependable check can be made at the start of the reel by contacting the tape between the reel idler and head assembly (where it is not necessary to remove the head cover to provide room). The percentage of speed error is determined the same as when using the strobosticker (previously described).

NOTE

Using any method of checking tape speed, the speed is defined in relation to the power line frequency. For example, an absolute speed error of 0.2% would occur if the power line frequency varied 1/8 cps from a normal 60 cps. Also note, however, that such error is automatically compensated for when a strobe is used to check speed.

4.1.10 Checking Flutter and Wow

Heads and all components in the tape path must be cleaned and demagnetized before checking flutter. The normal measurement procedure is to reproduce a standard flutter tape, which is relatively flutter-free, and check the flutter content with the flutter meter. When a standard tape is not available, the measurement is made by following the instructions given with the flutter meter, which generally will be to record a 3,000 cycle tone, rewind the tape to the beginning of the tone, and play it back through the flutter meter.

The most accurate measurement can be made by stopping and starting the transport four or five times during the reproduce run, noting the high reading each time. Then average the high readings. Maximum flutter is then approximately 70% of this average.

A discussion of flutter correction is given in paragraph 4.2.

4.2 CORRECTIVE MAINTENANCE

4.2.1 General

In addition to the equipment required for checkout procedures described in paragraph 4.1, the following adjustment and troubleshooting procedures require the following test equipment:

Spring Scale, 0-5 gram

Voltmeter, AC/DC

4.2.2 Adjusting Tape Tension Transducer (Holdback Tension)

The transducer is controlled by the holdback tension control arm between the turntable and

the supply idler. This arm must apply 3 (± 0.3) grams of force against the tape. This can be measured with the 0-5 gram spring scale, holding the arm away from its rest position with the scale to measure the force. If the transport is mounted in a console, it must be removed to adjust this force, which is adjusted by moving the tension control arm return spring to different holes in the air dashpot mounting bracket of the tension control assembly.

The first contact of the transducer should just be closed when the radius of the tape pack on the supply reel is 5.1 inches (the contact should open when the tape pack is less). This can be checked by using the special tool (see Fig. 4-1), a battery, and an indicating light to operate with the battery. Remove the connector to the tension control assembly from its receptacle (J514). Connect the battery and light in series across pins 1 and 11 of receptacle J514. (The indicating light should be illuminated at this point). Place the special tool on the supply turntable, mating it with the EIA drive hub. Place the string in the 5.1 inch notch on the tool, and move the tool to the approximate 9 o'clock position on the turntable. Pass the string to the left of the tension control arm and hold it taut so that it just touches the left side of the reel idler. Pull the tool so that its lower edge is at 90° to the string. The test light should still be illuminated, but any further movement inward of the tension control arm should result in the light being extinguished. If timing adjustment is required, the transport must be removed from the console. The Allen head timing screw is then available from the left side of the transport, through a hole in the air dashpot mounting bracket (see Fig. 4-3). Adjust

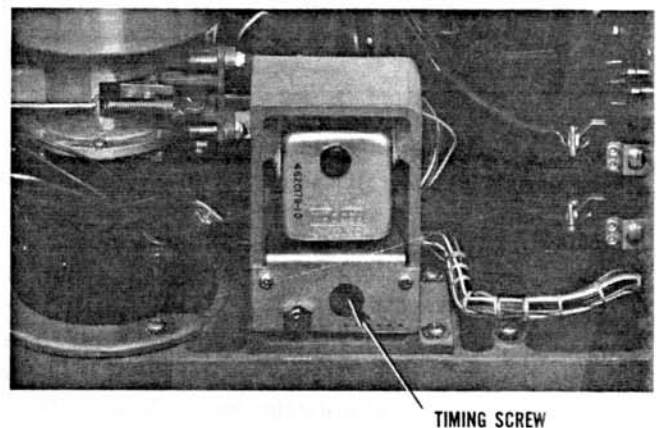

Fig. 4-3. Timing Adjustment--Transducer

this timing screw so that the test light is illuminated just at the point previously described.

If the force and the timing of the tension control is correct, the holdback tension should be within tolerances quoted in paragraph 4.1 throughout the run of a reel of tape.

CAUTION

Do not attempt to adjust holdback tension by changing the supply motor leads to different taps on the power transformer. Such action might result in surpassing the power rating of the motor.

4.2.3 Adjusting Takeup Tension

Takeup tension is dependent on the voltage, and thus the torque, supplied to the takeup motor during the play or record modes. Once the torque is adjusted at the factory, there should be no necessity for readjustment unless the motor is replaced, speed changed, etc. If readjustment is required, it is accomplished by changing the motor lead to a different tap on the power transformer. The normal connections are shown on Fig. 7-2, note that the "run" lead from the motor can be changed from its normal tap so that more "run" voltage is applied (torque and tension increased) or less is applied (torque and tension decreased). The transformer is located in the transport control box, and it is necessary to remove the perforated cover to gain access to it. Color coding of the leads is shown on Fig. 7-2. Do not change the "start" lead to the motor; this provides a starting power boost for approximately 1/2 second.

4.2.4 Adjusting Braking Force

Brake adjustments require that the entire supply or takeup assembly (as applicable) be removed from the transport. Brakes can be checked and adjusted with the assembly removed. There are two brake adjustments, one for the "high" brake force (counterclockwise rotation for supply, clockwise for takeup) and the other for the "low" brake force (see Fig. 4-4). Two nuts control the high side, while one controls the low. Be sure to run in the two nuts for the high side in equal amounts. When the adjustment is completed, manually actuate the brake solenoid and rotate the turntable,

making sure the mechanical brakes do not bind or drag.

4.2.5 Adjusting Capstan Idler Force

This adjustment is made at the capstan idler solenoid locknut (see Fig. 4-4). Run the nut in to increase force, out to decrease. When adjustment is completed, put the equipment in the play mode and check that the solenoid is bottomed (the idler can be easily pushed away from the capstan if the solenoid is not bottomed). If not bottomed, run the locknut out.

4.2.6 Adjusting Takeup Tension Arm

Make this adjustment with the micro-switch actuating screw on the takeup tension arm assembly underneath the transport. Run this screw in or out until the arm is in the proper position when it actuates the switch.

4.2.7 Adjusting Tape Speed

This adjustment is made by using the motor solenoid lock nut and a stop screw (see Fig. 4-5). Before starting the adjustment run both the stop screw and the lock nut out, so that the set screw does not bottom and the capstan is not driven. Then run the solenoid lock nut in; speed will first increase then will slow down below sync speed. Continue turning the solenoid lock nut until one spoke on the strobo passes a fixed point every 2-3 seconds. Then run in the stop screw until sync speed is attained, and set the lock nut on the stop screw. When the adjustment is completed speed must be correct and the stop screw must be firm against the stop when the equipment is in the play mode.

When using the tape strobe (Dubbings Electronics) remove the head cover and contact the tape with the disc between the head assembly and the capstan. Adjust the speed at the start of a reel (1/2-inch tape pack on takeup reel). Then check the speed at the end of the reel (1/2-inch tape pack left on supply reel). Speed at both points must be within tolerance, if not, adjust to an optimum speed which is within tolerance at both points on the reel.

4.2.8 Correcting Excess Flutter and Wow

Flutter can be caused by any component in the transport that affects tape motion. It is manifestly impossible in this manual, therefore, to delineate specific causes and remedies.

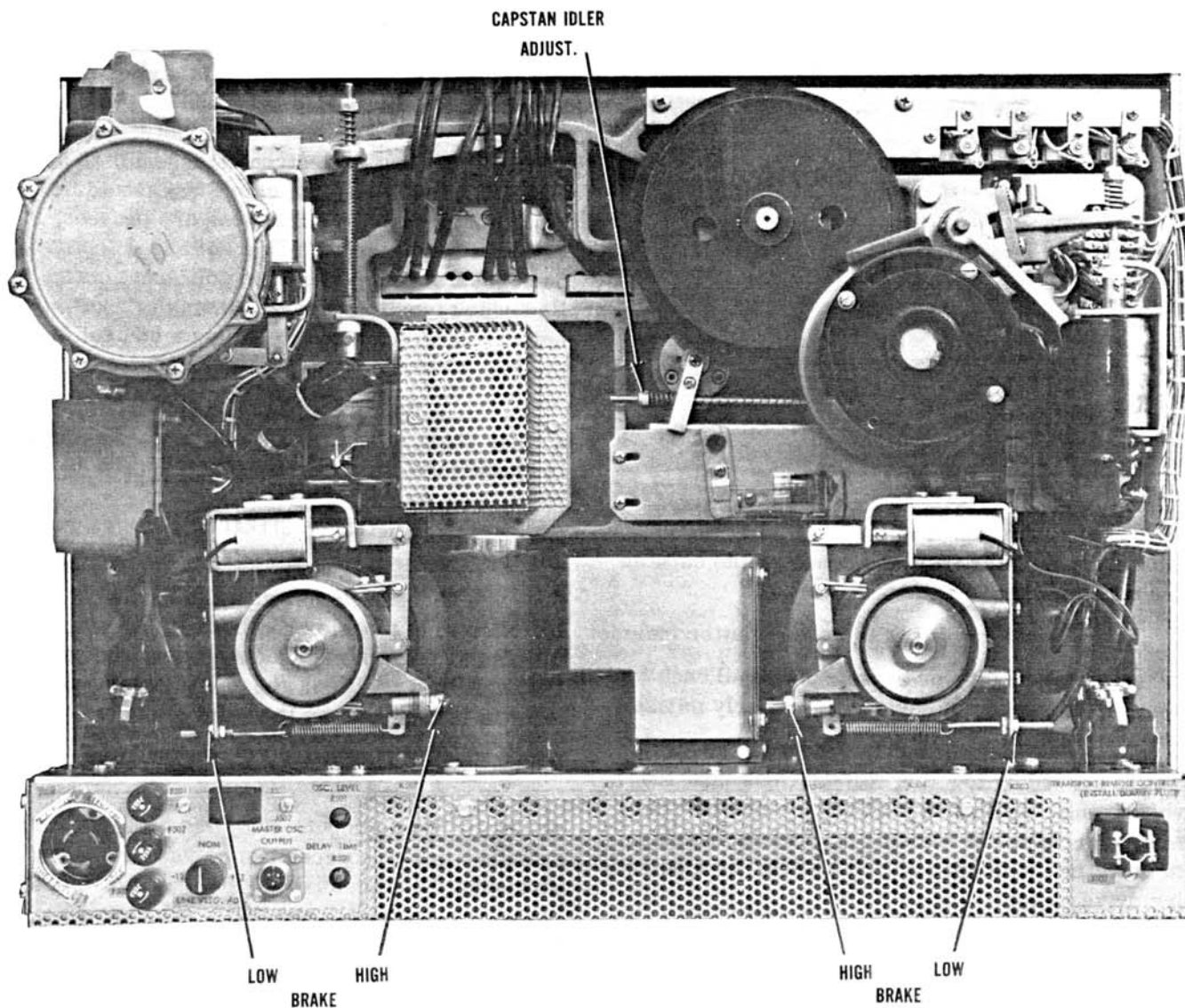

Fig. 4-4. Brake and Idler Adjustment

COMPONENT	ROTATIONAL FREQUENCY (RPS)		
	7-1/2 ips	15 ips	30 ips
Drive Motor	30	60/30	60
Drive Motor Vibration	120	120	120
Capstan and Flywheel	5	10	20
Capstan Idler	1.2	2.4	4.8
Reel Idler	1.6	3.2	6.4

If a tunable filter (e.g. General Radio Model 1564A Sound Vibration Meter) is available, excessive flutter can be isolated to certain fre-

quencies. This is accomplished by connecting the filter to the output of the flutter meter. Starting at (for example) 2.5 cycles per second, sweep upward and note those frequencies which show flutter greater than .02%. Proceed in this manner to 250 cps. Comparing the results with the table, Rotational Periods of Components, may then isolate the offending assembly.

Note that if flutter disturbance is introduced by components in the supply turntable assembly, the frequency of the flutter will vary--being low when the supply reel is full of tape and progressively increasing with reel rotation as the tape pack diminishes. It is very rare for the take-up reel to contribute appreciably to flutter, as it is

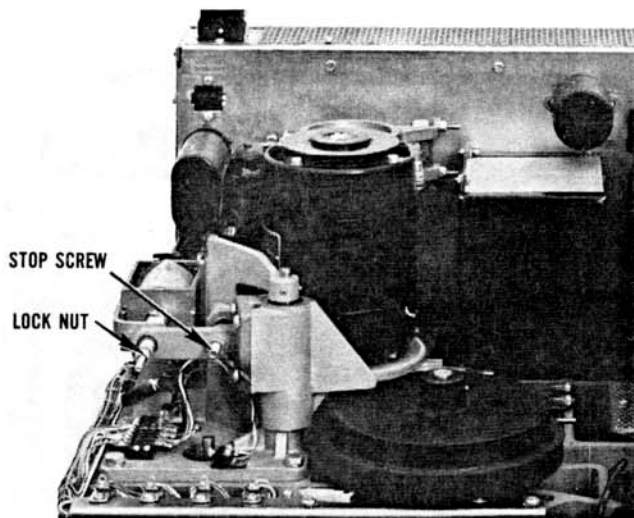

Fig. 4-5. Tape Speed Adjustment

effectively isolated from the heads by the capstan and capstan idler.

Possible causes of excess flutter include:

Excessive or erratic play hold back tension (tension control device not properly adjusted).

Drivemotor not in synchronism--This can be caused by low line voltage (less than 105 volts input); excessive play takeup tension; defective drive motor starting capacitor; bearings in drive motor in need of lubrication; or a defective drive motor.

Capstan Idler--The idler tire may be defective, or the bearing may be in need of lubrication or be defective.

Capstan Flywheel--Rubber tire may be defective.

Capstan--Can be out-of-round or bent.

Tape Scrape--Can be caused by warped or damaged reels, or incorrect turntable height.

Reel Idler--Can be out-of-round, or bent.

4.2.9 Troubleshooting Control Circuits

Standard troubleshooting procedures should quickly isolate malfunctions in the control circuits. In fact, visual observation while manipulating different controls will many times serve to isolate any trouble to a component or circuit. For example, assume the capstan does not rotate after the POWER pushbutton is pressed.

The trouble could be among power line fuses F501, F502, and F503, or F505 in the solenoid power supply. If the POWER and HI/LO indicators are illuminated it would indicate F505 was the fuse to suspect. If these indicators are not lit, but the vu meter lights on the electronics assemblies are illuminated, it would indicate F503 should be checked. If none of these indications are present, it is probable that either F501 or F502 is defective. Such observation, while using different controls to find which functions operate normally and which do not will usually suffice to isolate a control problem so that the trouble can be easily repaired.

A fusing diagram is given in Fig. 4-6 and a relay chart in Fig. 4-7. Use an ac-dc voltmeter to check voltages in the circuit.

4.3 PRINCIPLES OF OPERATION

4.3.1 General

Schematic diagrams in Section 7 should be followed in trouble shooting. In the schematic diagrams, certain relay contact sets are shown in the energized position; the energized position of all sets is indicated by the solid contact.

4.3.2 Transport Control Power Supply (See Figure 7-1)

4.3.2.1 Power Input: Note that either 115 or 230 volts a-c power sources can be used by properly strapping the transformer (and the electronics power transformer), and that a selector switch can be positioned to compensate for approximate ± 12 volt variations from these nominal power line voltages.

4.3.2.2 Capstan Drive Motor Circuit: As shown on this diagram (Fig. 7-1), whenever power is
(Continued on Page 4-12)

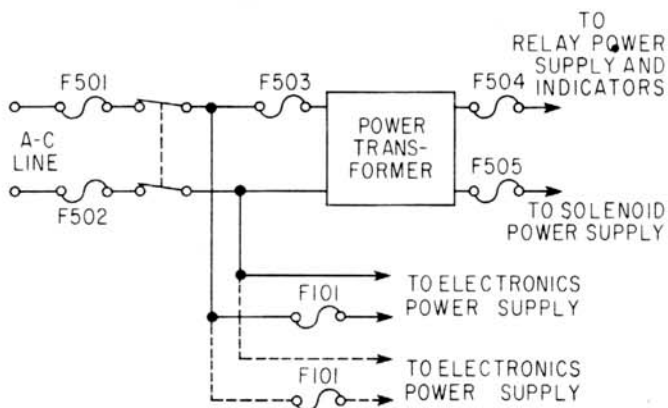

Fig. 4-6. Fusing Diagram

CONTROL LOCATION	MODE	TRANSPORT RELAYS							REM. CONTR.	
		K501 FAST	K502 SAFETY	K503 PLAY	K504 RECORD	K505 DELAY	K506 EDIT	K507 EDIT HOLD	REM. FWD.	REM. REW.
	TAPE NOT THREADED	o	o	o	o	*	o	o	o	o
TRANS-PORT	STOP	o	*	o	o	*	o	o	o	o
	PLAY	o	*	*	o	*-o	o	o	o	o
	RECORD	o	*	*	*	*-o	o	o	o	o
	FAST	*	*	o	o	*-o	o	o	o	o
	EDIT-STOP	o	*	o	o	*	*	*	o	o
	EDIT-PLAY	o	*	*	o	*-o	*	*	o	o
	EDIT-FAST	*	*	o	o	*-o	*	*	o	o
"EDIT" FOOT PEDAL	EDIT-STOP	o	*	o	o	*	*	o	o	o
	EDIT-PLAY	o	*	*	o	*-o	*	o	o	o
	EDIT-FAST	*	*	o	o	*-o	*	*	o	o
REMOTE CONTROL BOX	STOP	o	*	o	o	*	o	o	o	o
	PLAY	o	*	*	o	*-o	o	o	o	o
	RECORD	o	*	*	*	*-o	o	o	o	o
	FWD.	*	*	o	o	*	o	o	*	o
	REW.	*	*	o	o	*	o	o	o	*
	GATE CLOSE FWD. or REW.	*	*	o	o	*	*	o	(*) OR (*)	

o = DE-ENERGIZED
 * = ENERGIZED
 *-o = STARTS ENERGIZED & DE-ENERGIZES AFTER APPROXIMATELY 1/2 SECOND DELAY

Fig. 4-7. Relay Operating Chart

MR-70 TRANSPORT CONTROL BOX
 RELAY DESIGNATIONS AND FUNCTIONS

SYMBOL	NAME	CONTACT	WIRE COLOR	FUNCTION
K 501	FAST	R1	2 Bk/Wh	Play circuits (lockout in "Fast")
		R2	2 Bn/Wh	
		R3	Or	Holds Fast Relay
		R4	NC	NC

<u>SYMBOL</u>	<u>NAME</u>	<u>CONTACT</u>	<u>WIRE COLOR</u>	<u>FUNCTION</u>
		R5	2 Bk	
		R6	2 Rd	Energizes all brake solenoids
		L1	Gy	DC in reel motors in "Stop Edit" (lockout in "Fast")
		L2	Bn	
		L3	2 Vi	Reel motors power in "Fast"
		L4	NC	NC
		L5	Yel	
		L6	2 Or/Wh	Remote "Gate Close" circuit
K 502	SAFETY	R1	NC	NC
		R2	Bk/Wh	
		R3	Yel	"Stop" circuit
		R4	NC	NC
		R5	NC	NC
		R6	NC	NC
		L1	NC	NC
		L2	2 Bk	
		L3	Or	Energizes Capstan Motor Solenoid
		L4	NC	NC
		L5	Rd	
		L6	2 Gn	Capstan Motor Power
K 503	PLAY	R1	Bn/Wh	"Stop" and Delay Relay circuits
		R2	Bk/Wh	
		R3	Rd/Wh	Holds Play Relay
		R4	Or	Energizes Headgate or Take-up Brake Solenoids
		R5	2 Bk	
		R6	2 Yel	Energizes Capstan Idler and Reel Idler and Supply Motor Solenoids
K 503 (Continued)	PLAY	R7	Bn	Part of DC circuit in reel motors in "Edit"
		R8	Blu/Wh	
		R9	Vi	Supply Motor power in "Play"
		L1	Or/Wh	Supply Motor power in "Play"
		L2	Blu	
		L3	Gy	Supply Motor power in "Fast"
		L4	Or/Wh	Take-up Motor power in "Fast"
		L5	2 Wh	
		L6	Blu/Wh	Take-up Motor power in "Play"
		L7	NC	NC
		L8	2 Rd	
		L9	Gn	Reel Idler Motor power in "Play"

<u>SYMBOL</u>	<u>NAME</u>	<u>CONTACT</u>	<u>WIRE COLOR</u>	<u>FUNCTION</u>
K 504	RECORD	1	2 Bk	"Edit" circuits (lockout in "Record")
		2	2 Bn/Wh	
		3	NC	NC
		4	Gn	"Play" Indicator (lockout in "Record")
		5	2 Rd/Wh	
		6	NC	NC
K 505	DELAY	R1	NC	NC
		R2	Blu	
		R3	2 Bn	Capstan Idler Solenoid power boost
		R4	NC	NC
		R5	2 Or	
		R6	2 Bn	Reel Motors Brakes power boost
		R7	Bn/Wh	Fast Wind Control circuit
		R8	2 Or/Wh	
		R9	Rd/Wh	Remote Fast Wind circuit
		L1	Bk/Wh	Takeup Motor power boost (run)
		L2	Blu/Wh	
		L3	Wh	Takeup Motor power boost (start)
		L4	NC	NC
		L5	Rd	
		L6	Gn	Reel Idler Motor power
		L7	NC	NC
		L8	Vi	
		L9	Gy	DC in reel motors in "Stop-Edit"
K 506	EDIT	R1	NC	NC
		R2	Bn	
		R3	Vi	DC in reel motors
		R4	2 Blu	Headgate Solenoid (lockout in "Edit")
		R5	Or	
		R6	2 Rd	Energizes all Brake Solenoids
		R7	Rd	Energizes Takeup Motor Brake in "Play" (lockout in "Edit")
		R8	2 Gn	
		R9	NC	NC
		L1	Yel/Wh	"Play" button circuit (lockout in "Edit")
		L2	Bk/Wh	
		L3	Wh	Energizes Safety Relay (lockout in Safety Switch in "Edit")
		L4	Gy	Remote Stop Indicator (lockout in "Edit")
		L5	Rd/Wh	
L6	NC	NC		
L7	Vi/Wh	Takeup motor power (lockout in "Play-Edit")		

<u>SYMBOL</u>	<u>NAME</u>	<u>CONTACT</u>	<u>WIRE COLOR</u>	<u>FUNCTION</u>
		L8	Blu/Wh	
		L9	NC	NC
K 507	EDIT HOLD	1	NC	NC
		2	Vi	
		3	2 Bk	Holds Edit Hold Relay
		4	NC	NC
		5	Or/Wh	
		6	Bk	Holds Edit Relay

applied, tape properly threaded (safety relay K502 energized), and either the dummy plug (provided) or a capstan motor drive amplifier plugged into J506, the drive motor will operate at the speed selected by S502.

CAUTION

If a motor drive amplifier is used with 230 volt power, supply it with its own power source, and connect the precision a-c power to pins 2 and 5 of J506. Do not attempt to power the amplifier from pins 1 and 4 of this connector as the power transformer may be overloaded and damaged. This danger is not present when using 115 volt power, where the amplifier would be connected directly across the power line rather than the transformer.

4.3.2.3 Rectifier and Indicator Circuit: This circuit, shown in Fig. 7-1, furnished d-c power (+24 volts, nominal) to the relays in the transport control logic and to the equalization relay in the electronics assemblies. In addition, it supplies the power indicator and the high and low tape speed indicators. It is a conventional circuit throughout. Note that the tape speeds available are 7-1/2 - 15 ips or 15 - 30 ips, and that the 15 ips speed is thus common to both versions. To simplify the construction of the electronics assembly, the equalization relay selects the 15 ips equalization when de-energized. The relay must therefore be energized in one combination at the low speed, in the other at the high speed. This is accomplished

at the printed circuit board by strapping terminals 8 - 11 and 9 - 10 for 7-1/2 - 15 ips equipment, terminals 8 - 10 and 9 - 11 for 15 - 30 ips equipment. When the relay is not energized, resistor R502 maintains a relatively constant load on the power supply.

4.3.3 Transport Logic Circuits (See Figures 7-2 and 7-3)

4.3.3.1 General: The discussions which follow describe the action of the logic circuitry for each mode of operation. Before operation in any mode, power must be applied, and safety relay K502 (controlled by safety switch S505 in conjunction with the takeup tension arm) must be energized. Contacts of relay K502 are in series with the STOP pushbutton switch, in the a-c line to the capstan drive motor, and in the d-c line to the capstan motor solenoid. Thus, when tape is properly threaded (safety switch S505 closed) and power is applied, the capstan will be rotating and the transport is in the stop mode. The tape will be lifted from the heads by the action of tape lift solenoid K509 (tape contacts the heads only in the play, record, or edit modes of operation). Also, in the stop mode delay relay K505 is energized; when tape motion starts in any mode the relay remains energized approximately 1/2 second to give a starting power boost to motors and solenoids, then drops out.

4.3.3.2 Play Mode: When the Play pushbutton is pressed, play relay K503 is energized through normally closed contact sets R2-R1 of fast relay K501, L2-L1 of edit relay K506, and 4-5 of record relay K504. Contact set R2-R1 of the play relay breaks, removing power from delay relay K505-- which remains energized for the time dictated by

the delay circuit, then de-energizes. Contact set R2-R3 makes, forming a holding circuit for the play relay. Contact set R5-R6 of the play relay closes, energizing the capstan idler, supply motor brake, reel idler motor brake, and takeup motor brake solenoids (the last through normally closed contact set R8-R7 of edit relay K506). The pull-in of the capstan idler is damped by an air dashpot to prevent a momentary tape slack and consequent loss of head-to-tape contact, which might occur if the idler abruptly clamped the stationary tape to the rotating capstan. The dashpot provides a rapid but gradual application of full capstan idler clamping action. Note that contacts R2-R3 and R5-R6 of delay relay K505 (shown in their energized positions) short out resistors in the ground return for the capstan idler and reel motor brake solenoids, thus providing a pull-in power boost while the delay relay is energized. In the motor circuit, (Fig. 7-2) contact set L5-L6 of play relay K503 closes. A-c power is then applied to the takeup motor through edit relay contact set L8-L7 and delay relay contact set L2-L3 (momentary start boost) and then L2-L1 (normal run). Contact set L8-L9 of the play relay closes, and a-c power is delivered to the reel idler motor for the time that the delay relay is energized (contact set L5-L6 of the delay relay open); the voltage to this motor is determined by the placement of high-low speed switch S502C. Power to the supply motor is applied through contact sets R8-R9 and L2-L3 of the play relay, and through the constant tape tension control. The tensioning transducer (Fig. 7-2) is controlled by the position of a lever arm in the tape path at the supply reel. The lever arm is moved to the right by the tape as the pack on the supply reel diminishes and it is the position of the lever that controls holdback tension. An air dashpot damps the movement of the lever to the right, so that it maintains steady but light contact with the tape; no damping is provided in the other direction and the arm can move quickly to the left if tape becomes slack. At the start of a full supply reel the lever position is such as to close all contacts, and full holdback power is applied to the supply motor. As the tape pack diminishes, the position of the lever changes and allows sequential opening of contacts to add more and more resistance in the motor circuit. A dither coil is powered from a 6.3 volt winding on the transformer, and produces a force that increases and decreases at twice the rate of the supply frequency (100 or 120 times per second).

This force causes a repetitive motion of the actuating mechanism, which acts to average the resistance values and smooth out the resultant power curve-- which otherwise would be in clearly defined steps. Thus the torque of the supply motor is changed in a smooth curve, from relatively high torque at the beginning of a reel to low torque at the end. In the play mode, tape is in contact with the heads and is driven by the capstan at the selected speed, with holdback tension essentially constant and the takeup turntable reeling in the tape. Any signal recorded on the tape will be reproduced through the electronic assembly.

4.3.3.3 Record Mode: When the record pushbutton is pressed transport (see Fig. 7-3) record relay K504 receives +24 volts through contact sets R2-R1 of fast relay K501 and L2-L1 of edit relay K506. The +24 volts is also routed through the interconnecting cabling to record relay K102 in the electronics assembly (see Fig. 7-4) and that relay is energized if record selector switch S105 is in the READY position. (The record selector switch on the electronic assembly for at least one channel must be in the READY TO RECORD position or the transport will not operate). The +24 volt line then is returned to the transport circuit through contact set L5-L6 of the electronics record relay. At the transport it is routed to play relay K503 and energizes that relay, thus starting the transport as in the play mode. Contact set R2-R3 of the play relay forms a holding circuit for the play relay, and also for electronics record relay K102 and transport record relay K504 (both through contact set L5-L6 of the electronics record relay). Thus when the record pushbutton is released, both the transport and electronics record relays and the play relay are held energized. Contact set 1-2 of record relay K504 breaks, and the circuit to the edit relays is broken, so that accidental pressing of the edit pushbutton will not spoil a recording. Contact set 4-5 breaks and prevents the play indicator from lighting even though the play relay is energized. Solenoid and motor circuit action is controlled by contacts of the play relay, exactly as described in paragraph 4.3.3.2.

4.3.3.4 Fast Mode: When the fast pushbutton is pressed (see Fig. 7-3) fast relay K501 is energized. Contact set R2-R1 breaks, removing power from the play, record, and delay relays (if the equipment is operating in play or record those modes will drop

out). As in the play or record modes, the delay relay will remain energized for the time dictated by the delay circuit. Contact set R2-R3 of the fast relay makes and forms a holding circuit for the fast relay. Contact set L5-L6 makes and provides a "gate closing" circuit for the fast mode from the optional remote control. In the solenoid circuit, capstan motor solenoid K507 is actuated through safety relay contacts L2-L3, so the capstan continues in rotation (the capstan idler solenoid is de-energized so that capstan will have no effect on tape motion). Tape lift solenoid K509 is energized through contact sets R5-R4 of the de-energized play relay and R5-R4 of the de-energized edit relay. Contact set R5-R6 of the fast relay makes, energizing the brake solenoids of the takeup, supply, and reel idler motors, and releasing the brakes. Note that delay relay contact set R5-R6 provides a momentary pull-in boost to the takeup and supply brake solenoids. In the fast mode, no power is applied to the reel idler motor and that component acts strictly as an idler in the tape threading path. In the torque motor circuit (see Fig. 7-2) fast relay contact set L3-L2 makes, connecting the supply motor to one side of the power transformer through contact set R7-R8 of the play relay. The takeup motor is connected directly to the other side of the transformer. The supply motor return lead is through contact set L2-L1 of the play relay, that for the takeup motor through contact set L5-L6 of the same relay. The return leads are then connected together and routed through contact set R8-R7 of the delay relay (after that relay is de-energized) to the slider arm of fast forward control S504. Note that as this slider arm is moved up (as depicted on the diagram) the voltage applied to the takeup motor will increase and that to the supply motor will decrease. When the slider is moved down, the voltage to the supply motor will increase, that to the takeup will decrease. Since the brakes are released, the motor with the highest torque will overcome the lesser opposing torque of the other motor, and tape will be pulled from one reel to the other. The speed of tape motion is governed by the differential, which in turn is controlled by the position of the slider arm. The slider can be moved from a fast forward to rewind position (or vice versa) and tape motion will slow to a stop, then reverse direction.

4.3.3.4 Stop-Edit Mode: In this mode, delay relay K505 remains energized, mechanical brakes on each reel motor are released, a d-c voltage is

applied across the windings of the two motors in series to provide hysteresis braking, and the tape lift solenoid is de-energized. The equipment is designed so that the editing function can be controlled with a foot pedal, leaving both hands free. If the foot pedal is not used and the mode is controlled by the edit pushbutton on the transport, a hold relay (507) is energized so that the pushbutton can be released without dropping out the edit mode. When the edit pushbutton is pressed (Fig. 7-3) edit hold relay K507 is energized and its contact sets 2-3 and 5-6 form holding circuits for both that relay and edit relay K506. If the accessory foot pedal is used for editing, only relay K506 is energized and no holding circuit is provided; thus the edit mode is held while the pedal is pressed and drops out when the pedal is released. Contact set L2-L1 of the edit relay breaks, removing power to the play and record pushbutton, so those modes cannot be started. Contact set L2-L3 makes, and safety relay K502 is energized independently of the safety switch which need not remain closed. In the solenoid circuit, the capstan motor solenoid is energized through contact set L2-L3 of the safety relay. Contact set R5-R4 of the edit relay breaks, and the tape lift solenoid is de-energized. Contact set R5-R6 makes, and the takeup, supply, and reel idler motor brake solenoids are energized, releasing the brakes on those motors. (Since the delay relay remains energized, the solenoids will operate under pull-in power during editing but still operate within their power ratings.) In the torque motor circuit, the a-c voltage at the power transformer secondary is rectified by CR511 and CR512, then routed through R511/R512, contact sets R2-R3 of the edit relay, L8-L9 of the delay relay, L1-L2 of the fast relay, R7-R8 of the play relay, the supply motor, contact sets L2-L1 and L4-L5 of the play relay, and the takeup motor back to the other side of the line. Hysteresis braking is thus applied by the d-c current through the two motor windings, connected in series. With the mechanical brakes released and the tape against the heads, the reels can be manually rotated for precise cueing or editing (the stop-edit mode also can be used to release the mechanical brakes when threading tape). Referring to Fig. 7-2, it will be seen that both the stop and edit indicators on the transport control panel will be illuminated, but that the stop indicator on the remote control (if that accessory is used) will be extinguished by the breaking of edit relay contact set L5-L4 (no edit indicator is provided on the remote control, as editing would not be accomplished from that posi-

tion). Extinguishing the remote control stop indicator is simply a safety measure to minimize the possibility of someone attempting to operate the equipment from the remote station while editing is in process (it is possible to enter fastwinding modes from the remote control).

4.3.3.6 Play-Edit Mode: To enter this mode, it is necessary to first push the play pushbutton, then the edit pushbutton (or press both buttons simultaneously). All functions described in paragraph 4.3.3.2 are thus in operation before the edit pushbutton is pressed (this includes de-energizing the delay relay K505 in this mode). The energizing of the edit relay K506 is the same as described in paragraph 4.3.3.5. Note, however, that although the play pushbutton is locked out, play relay K503 is held energized by holding contact set R2-R3 of K506. In the solenoid circuit (Fig. 7-2) the play, safety, and delay relay contacts are shown in their energized positions. The capstan motor, capstan idler, supply motor brake, and reel idler motor brake solenoids are all energized, and the tape lift solenoid de-energized, as in the play mode. However, the takeup motor brake solenoid is de-energized by the breaking of edit relay contact set R7-R8, thus the mechanical brake is applied to that motor in the play-edit mode. The torque motor circuit is the same as described in paragraph 4.3.3.2, except that power to the takeup motor is removed (by breaking edit relay contacts L7-L8.) Thus, the tape, in contact with the heads, will move at the selected speed. It can be monitored as in the play mode, but the takeup reel will remain stationary and tape will spill from the right side of the transport.

4.3.3.7 Fast-Edit Mode: Transport operation, with one exception, is exactly the same as described in paragraph 4.3.3.4. The exception is that the tape lift solenoid is de-energized by the breaking of contact set R5-R4 of the edit relay. The tape thus is in contact with the heads and can be monitored during fast winding--in either the forward or rewind direction. As described in paragraph 4.3.3.4, a "gate closing" circuit is provided to the optional remote control which allows monitoring in the fast-winding mode at that unit.

4.3.4 Master Bias and Erase Oscillator

This circuit is contained in a plug-in module which is inserted in receptacle J501 on the tape transport. As shown on the schematic diagram (Figure 7-7) the oscillator employs a conventional push-pull circuit utilizing transformer taps as the feedback device. Plate voltage for oscillator nuvistors V701 and V702 is regulated by Zener diode CR701 at 100 volts. The oscillator is coupled to a push-pull, cathode follower, output stage (V703 and V704), which provides isolation for the oscillator and low output impedance to the individual bias and erase amplifiers in each electronic assembly.

The master bias and erase oscillator operates continuously whenever power is applied to the equipment. Control is established by connecting plate voltage to the nuvistors in the individual amplifiers on the electronics only during the record mode. The output level of the master oscillator is adjusted at R501 and the output is taken at J502 on the tape transport. Nominal oscillator frequency is 150,000 cps.

ELECTRONIC MAINTENANCE

5.1 GENERAL

5.1.1 Basic Setup

Adjustment points for the electronic assemblies are located on the front panel, behind a cover which is secured by two screws. Remove the cover to gain access to these points.

There are four selector switches on the panel which must be positioned in accordance with the type of equalization desired before starting the checkout procedure.

15 ips

HIGH FREQUENCY EQUALIZATION, SELECT--Three positions, NAB, CCIR, AME

LOW FREQUENCY EQUALIZATION, SELECT--Two positions, NAB/AME, CCIR

7-1/2 or 30 ips

HIGH FREQUENCY EQUALIZATION, SELECT--Three positions, 7-1/2NAB/30CCIR, 7-1/2 CCIR, 30 (17.5 Microsecond)

LOW FREQUENCY EQUALIZATION, SELECT--Two positions, NAB, CCIR/30

5.1.2 Adjustment Points

Above each HIGH FREQUENCY EQUALIZATION, SELECT control are three RECOrd equalization adjustment points, one for each selection.

Below these controls are three REProduce equalization adjustment points. One REProduce adjustment is provided for each LOW FREQUENCY EQUALIZATION, SELECT control.

A REProduce HF (high frequency) GAP LOSS ADJUSTment is located adjacent to each LOW FREQUENCY EQUALIZATION, and a single LOW FREQ. HEAD COMPENSATION control and strapping arrangement are included in approximately the center of the panel.

Four other controls--BIAS ADJ, BIAS METER CALIB, RECORD, CALIB, and SYNC CALIB--complete the adjustment panel.

5.2 CHECKOUT AND ADJUSTMENT USING STANDARD TAPE

5.2.2 General

Ampex Standard Reproduce Alignment Tapes and Level Set Tapes are available for certain configurations of this equipment, and their use when possible will simplify the checkout and adjustment procedure.

In aligning the equipment, the playback function is first aligned to a standard by using an Ampex Standard Tape. The record function is then aligned using the playback circuit as a reference.

Standard alignment tapes are precisely recorded in an Ampex laboratory under stringently-controlled conditions. They must be handled and stored with proper care if they are to retain their

usefulness over extended periods of time. Heads and tape guides should be cleaned and demagnetized before the standard tape is installed on the equipment, and the tape should not be stored where temperature and humidity extremes occur. Also, the tape should be stored under the tape tension encountered in a normal play run, not after being rewound. After extended use, the tape life will begin to fade--for example, the head azimuth tone may be down as much as 2 db.

When the standard tape is first run, it should be moved in the fast forward mode to the take-up side, then rewound to another reel (not the standard tape reel). The standard tape reel is then placed on the takeup turntable and tape threaded to it. This allows storage on the original reel without rewinding. Subsequent runs are made by putting the standard tape on the takeup turntable and rewinding to an empty reel on the supply turntable before proceeding with the reproduce alignment.

Before any checking and adjusting of the equipment, heads and tape guides should be cleaned and demagnetized. In the procedures which follow, this is called out only under Reproduce Alignment in the expectation that a complete check-out will ensue. However, if any test or adjustment is made independently it must be preceded by the cleaning and demagnetizing procedure.

Test equipment required is as follows:

Ampex Standard Alignment Tapes--1/4 inch--as necessary.

15 ips NAB	01-31311-01
15 ips CCIR	01-31313-01
15 ips AME	01-31312-01
7-1/2 ips NAB	01-31321-01
7-1/2 ips CCIR	01-31323-01
30 ips	(Special Order)

Ampex Standard Alignment Tapes--1/2 inch--as necessary.

15 ips NAB	01-31311-05
15 ips CCIR	01-31313-05
15 ips AME	01-31312-05
7-1/2 ips NAB	01-31321-05

A-C Vacuum Tube Voltmeter

Audio Signal Generator

Wave Analyzer

Filter for Noise Measurement (Fig. 5-1)

5.2.2 Reproduce Alignment

NOTE

If the head assembly has been changed, complete the Low Frequency Head Compensation procedure for the reproduce head (refer to paragraph 5.4) before starting the reproduce alignment.

Step 1: Clean and demagnetize the head assembly (refer to Section 6).

Step 2: On equipment where head azimuth is adjustable, remove the head cover by opening the head gate and loosening the two Allen head set screws which are located inside and near the upper edge of the cover. The cover will then lift off.

Step 3: At each electronic assembly, place the RECORD SELECTOR switch in the SAFE position.

Step 4: At the electronic assembly for the channel to be tested, place the METER switch in the OUTPUT position and the OUTPUT SELECTOR switch in the REPRODUCE position.

Step 5: At the tape transport, apply power and select the 15 ips tape speed.

Step 6: The output of the channel is terminated (at the factory) with a 560 ohm or 150 ohm resistor, as required for the particular equipment. Connect the vtm to the line out connector.

Step 7: Thread the applicable standard alignment tape on the equipment.

CAUTION

Be sure all electronics are in the SAFE condition, before threading the standard tape on the transport.

Step 8: Press the Play pushbutton to start the tape in motion in the reproduce mode.

The first tone on the tape is 700 cps; when this tone is reproduced, adjust the REPRODUCE LEVEL control to achieve a convenient indication on the vtm.

Step 9: The next tone on the tape is 15,000 cps. On equipment with adjustable reproduce head azimuth use a 1/4-inch spintite wrench to adjust the left hand elastic stop nut (on top of the head) for a maximum indication on the vtm.

Step 10: Rewind the standard tape to the beginning of the first tone (700 cps). Start tape in motion in the playback mode, and as the 700 cps tone is reproduced adjust the REPRODUCE LEVEL control to achieve a +8 dbm or a +4 dbm indication on the vtm (level will depend on whether the equipment is strapped for a +8 or +4 vu output). Lock the REPRODUCE LEVEL control in that position. Do not change the setting of this control, as it will act as a reference for the record alignment.

Step 11: When the 15 kc tone is again reproduced, adjust the REP HF GAP LOSS ADJ if required to achieve a flat response in reference to the 700 cps tone.

Step 12: Check response as the balance of the tones on the tape are reproduced. Adjust the appropriate 15 ips HIGH FREQUENCY EQUALIZATION--REP control as required to achieve a flat response (within specifications).

NOTE

When multi-track heads are used, readings taken below 700 cps are invalid when using a standard tape. The tapes are recorded full track, and the "fringe" effect that occurs results in high indications at lower frequencies. This effect does not occur when tapes are recorded and reproduced with heads of the same configuration.

Step 13: If any adjustment was required in Step 11, repeat Step 10, and recheck Step 11.

Step 14: Work back and forth between Steps 11 and 12 as required to achieve the flattest possible response.

Step 15: When the test is completed, allow the standard tape to continue in motion in the

play mode until it is completely wound on the takeup reel.

Step 16: Replace the head cover if it was removed in Step 2.

5.2.3 Erase Adjustment

Erase current has been adjusted at the factory, using a clip-on a-c current probe, to approximately 65 milliamps. One adjustment on the tape transport--R501, which is accessible on the transport control box--sets the master bias oscillator level and thus controls the current to all erase heads. The amount of erase current is not critical if proper erasure is achieved (see paragraph 5.2.9).

Note that when the METER SELECTOR switch is placed in the ERASE position the vu meter monitors erase voltage (not current). The meter can indicate anywhere between -5 and +3, depending on the track width of the erase head. The meter therefore will only indicate that the erase system is operating normally.

Capacitor C306 of the bias amplifier on each electronic assembly is adjusted so that the output transformer of the bias amplifier and the erase head are in parallel resonance (this can be monitored on the vu meter). Do not attempt to adjust erase current by this means.

Whenever the setting of either R501 or C306 is changed, the record bias must be readjusted as explained in paragraph 5.2.4.

5.2.4 Record Bias Adjustment

NOTE

On this, and other, record adjustments blank tape is called out. Tape used can be either blank (bulk erased) or recorded with information not necessary to save (it will be erased during the record process). However, do not use recorded tape if it was recorded with a different head configuration, as the original recording might not be completely erased.

This is one of the most critical adjustment to be made. It must be accomplished with the type of tape which will normally be used (equipment specifications are based on the use of specific tape--refer to Section 1).

Step 1: At the electronic assembly for the channel to be checked place the RECORD SELECTOR control in the READY TO RECORD position, the OUTPUT SELECTOR in the REPRODUCE position, and the METER switch in the OUTPUT position.

Step 2: Apply power to the equipment, and select the 15 ips tape speed.

Step 3: Connect the signal generator to the input of the channel under test. Set it to 1,000 cps at a 1 volt level.

Step 4: Connect the vtvm across the line output of the channel under test.

Step 5: Thread blank tape on the equipment.

Step 6: Press the Record pushbutton to start tape in motion in the record mode, and adjust the RECORD LEVEL control to achieve an on-scale vtvm indication.

Step 7: While thus simultaneously recording and reproducing, adjust the BIAS ADJ control for a peak vtvm indication.

Step 8: Move the METER control to the BIAS position. Adjust the BIAS METER CALIB control as required to achieve a 0 indication on the vu meter of the electronic assembly.

Leave test equipment connected for adjusting the record level as described in the following paragraph.

5.2.5 Record Level Adjustment

The reproduce level must be adjusted to operating level as described in paragraph 5.2.2 before proceeding.

Step 1: Repeat Steps 1 through 5 of the bias adjustment procedure described in paragraph 5.2.4.

Step 2: Press the Record pushbutton to start tape in motion in the record mode.

Step 3: While thus simultaneously recording and reproducing, adjust the RECORD LEVEL control to achieve either a +8 or +4 dbm output (depending on the strapping of the individual equipment). Lock the control in that position.

Step 4: Change the OUTPUT SELECTOR switch to the INPUT position, and adjust the RECORD CALIB control as required to achieve a 0 indication on the vu meter.

Leave test equipment connected to check and adjust overall response.

5.2.6 Overall Response and Record Equalization Adjustment

Step 1: Repeat Steps 1 through 5 of paragraph 5.2.4.

Step 2: Press the Record pushbutton to start tape in motion in the record mode.

Step 3: Change the frequency of the signal generator as required and adjust the 15 ips LOW FREQUENCY EQUALIZATION control for the flattest possible response between 30 and 150 cps. This is accomplished by adjusting for equal levels of the highest peak and dip.

Step 4: Change the frequency of the signal generator as required, and adjust the 15 ips HIGH FREQUENCY EQUALIZATION--RECORD control for the flattest high end response in accordance with specifications.

Step 5: Make a complete frequency response run at 8 db below operating level, using discrete frequencies between 30 and 15,000 cps. Response should be within specifications quoted in Section 1.

5.2.7 Distortion Check

An accurate check of distortion on the magnetic tape recorder requires the use of a wave analyzer to measure individual distortion products. (An instrument which measures total harmonic distortion will be influenced by tape noise and modulation noise in addition to actual distortion.) Also, the signal generator must have low inherent distortion (less than 0.1%) or addition and cancellation can occur.

To check distortion, record a 500 cps tone on blank tape at normal operating level. On playback, the second harmonic component should

Note that signal-to-noise specifications are computed from peak record level, which is 6 db higher than normal record level. Therefore, add 14 db (+8 vu output) or +10 db (+4 vu output) to the vtvm indication to determine the actual signal-to-noise ratio.

5.2.9 Erase Efficiency Check

To check erase efficiency, record a 500 cycle signal at normal operating level. Rewind the tape to the beginning of the recording and re-record with no input signal. The remanent signal, as read on a wave analyzer, should be below -60 dbm (+8 vu output) or -64 dbm (+4 vu output). If required, the bias oscillator level may be increased slightly (see paragraph 5.2.3) to increase the erase current. Readjust the record bias if the level of the oscillator is changed.

5.2.10 Further Adjustment Procedure

The entire procedure previously described must be repeated for all channels, for all equalization types used, and for both tape speeds, using the applicable controls. Certain steps may be omitted as noted below when the second tape speed is checked.

Paragraph 5.2.2, Reproduce Alignment: Do not repeat the head azimuth adjustment performed at 15 ips. Do not change the setting of the reproduce level control which was adjusted at 15 ips. If second speed is 30 ips simply turn the REP HF GAP LOSS ADJ full counterclockwise; if it is 7-1/2 ips adjust as described.

Paragraph 5.2.3, Erase Adjustment: Disregard when checking the second speed.

Paragraph 5.2.4, Record Bias Adjustment: Disregard when checking the second speed.

Paragraph 5.2.5, Record Level Adjustment: Disregard when checking the second speed.

Paragraph 5.2.9, Erase Efficiency Check: Disregard when checking the second speed.

5.3 **CHECKOUT AND ADJUSTMENT WITHOUT STANDARD TAPE**

5.3.1 General

If an Ampex Standard Alignment Tape is not available the checkout and adjustment is more complicated, but the basic procedure is similar. Instead of the standard tapes, an induction loop,

such as the Ampex 4050238, is required; other test equipment is the same as called out in paragraph 5.2.1.

5.3.2 Playback High Frequency Equalization

Step 1: Open the head gate and clip the induction loop on the reproduce head, being sure it contacts the head at both the top and bottom of the stack.

Step 2: Connect the induction loop to the signal generator. Adjust the generator to 700 cps at an approximate 1 volt level.

Step 3: Terminate the line output of the channel to be tested with a 560 ohm or 150 ohm resistor as applicable to the particular equipment. Connect the vtvm across this load. Apply power to the equipment.

Step 4: Use pressure sensitive tape to hold the takeup tension arm away from its rest position, so the safety switch is released.

Step 5: At the electronic assembly for the channel to be tested, place the METER switch in the OUTPUT position and the OUTPUT SELECTOR switch in the REPRODUCE position. Turn both REP HF GAP LOSS ADJ controls full counterclockwise.

Step 6: Select the 15 ips tape speed, and press the Play pushbutton.

Step 7: Adjust the REPRODUCE LEVEL control to achieve any convenient level as indicated on the vtvm.

Step 8: Change the frequency of the signal generator as indicated, and adjust the 15 ips HIGH FREQUENCY EQUALIZATION control to achieve the indicated response (in relation to that set at 700 cps).

15 ips NAB	5,000 cps, +5.5 db
15 ips CCIR	10,000 cps, +7.7 db
15 ips AME	10,000 cps, +5.5 db

Step 9: Select the second tape speed and repeat Steps 7 and 8, adjusting the 7-1/2 - 30 ips HIGH FREQUENCY EQUALIZATION control to the following indication in relation to the 700 cps tone.

7-1/2 ips NAB	5,000 cps, +5.5 db
7-1/2 ips CCIR	5,000 cps, +10.2 db
30 ips (17.5)	10,000 cps, +3.5 db

30 ips CCIR 10,000 cps, +7.7 db

Leave test equipment connected to adjust the gap loss control.

5.3.3 High Frequency Gap Loss Adjustment

Step 1: Repeat Steps 1 through 7 of paragraph 5.3.2.

Step 2: Change the frequency of the signal generator as indicated, and adjust the 15 ips REP HF GAP LOSS ADJ to achieve the indicated response in relation to the 700 cps tone.

15 ips NAB 15 kc, +14 db

Step 3: Select the second tape speed and adjust the 7-1/2 - 30 ips REP HF GAP LOSS ADJ control to achieve the indicated response in relation to the 700 cps tone.

7-1/2 ips NAB 15 kc, +16 db

30 ips Leave full counterclockwise

After adjusting the gap loss, do not re-adjust high frequency equalization.

Leave the vtm connected for ensuing tests, but remove the induction loop.

5.3.4 Record Bias Adjustment

The record bias adjustment is made exactly as described in paragraph 5.2.4. Leave test equipment connected for ensuing tests.

5.3.5 Reproduce and Record Level Adjustment

With test equipment connected as in the Record Bias Adjustment, proceed as follows:

Step 1: Apply power and select the 15 ips tape speed.

Step 2: At the electronic assembly for the channel under test, place the METER switch in the OUTPUT position and the OUTPUT SELECTOR switch in the REPRODUCE position.

Step 3: If the equipment has an adjustable reproduce head, remove the head cover.

Step 4: Thread blank tape on the equipment and press the Record pushbutton to start tape in motion in the record mode.

Step 5: If the reproduce head is adjustable, set the signal generator to 15 kc at 1 volt out-

put. Adjust the RECORD and REPRODUCE LEVEL controls as necessary to achieve an indication on the vtm, and adjust the reproduce head azimuth for a maximum vtm reading.

Step 6: Turn the REPRODUCE LEVEL control to an arbitrary setting of 7 on the dial, and change the signal generator to 500 cps at 2 volts.

Step 7: Increase the RECORD LEVEL control until a maximum output is attained (tape is saturated). With the majority of professional quality magnetic tape, saturation occurs 13 to 14 db above operating level.

Step 8: Now adjust the REPRODUCE LEVEL control so that the vtm indication is 13 to 14 db above operating level. (On equipment strapped for a +8 vu output, the vtm indication will thus be +21 or +22 dbm; with equipment strapped for +4 vu output, it will be +17 or +18 dbm.) Lock the control at this setting.

Step 9: Now, adjust the RECORD LEVEL control so that the vtm indication is at normal operating level (either +8 or +4 dbm).

This adjustment of the reproduce and record levels can be checked by measuring third harmonic distortion at operating level.

5.3.6 Operating Checks

Check overall response, distortion, noise, and erase efficiency exactly as described in paragraphs 5.2.6 through 5.2.9.

5.4 LOW FREQUENCY HEAD COMPENSATION

This adjustment is made at the factory and there will be no need to readjust unless the head assembly is changed. The procedure requires the following test equipment:

Induction Loop, Ampex 4050238 or equivalent

Signal Generator

Vacuum Tube Voltmeter

Step 1: Follow Steps 1 through 4 of paragraph 5.3.2.

Step 2: At the electronic assembly for the channel to be tested, place the METER switch in the OUTPUT position, and the OUTPUT SELECTOR in the REPRODUCE position. Turn the

15 ips HIGH FREQUENCY EQUALIZATION selector to the NAB position, the LOW FREQUENCY EQUALIZATION selector to CCIR, and turn the LOW FREQUENCY EQUALIZATION REP ADJ control full clockwise.

Step 3: Select the 15 ips tape speed and and press the Play pushbutton.

Step 4: Adjust the REPRODUCE LEVEL control to achieve any convenient indication on the vtvm.

Step 5: Change the frequency of the signal generator to 70 cps, still at the one volt level. Adjust the LOW FREQUENCY HEAD COMPENSATION control so that the vtvm indication is the same as it was at 700 cps. If a greater range of control is required, proceed to Step 6.

Step 6: If it is impossible to achieve flat response in Step 5, remove the snap-in plug button immediately above the head compensation control. This will reveal TB-101 behind the front panel of the electronics. Note the strapping on that terminal board.

Step 7: Refer to Fig. 7-6. If the 70 cps response was down in Step 5, it will be necessary to remove some capacitance from the circuit (for example, the strapping on TB-101 could be changed from terminals 8-9-10 to 8-9 or 8-11 or 8-10). If the 70 cps response was up in Step 5, it will be necessary to add capacitance (for example, the strapping could be changed from 8-9-10 to 8-9-11). Restrap as required to enable the control to adjust to flat response at 700 cps and 70 cps in Step 5.

5.5 PRINCIPLES OF OPERATION

5.5.1 General

Simplified diagrams are provided throughout the descriptions that follow as an aid in understanding the circuitry. These diagrams should not be used for signal tracing procedures, as they are not complete in themselves. Complete schematic diagrams, which should be consulted when trouble shooting, are provided in Section 8.

5.4.2 Electronics Power Supply

A diagram of this circuit is shown in Figure 7-4. Note that the power transformer, like that in the tape transport, must be strapped in accordance with the line voltage for either 115 volts a-c or 230 volts a-c (both nominal). For 115

volt operation the two primary windings are connected in parallel by strapping terminals 56 to 57 and 58 to 59. These windings are connected in series for 230 volt operation by removing the 115 volt jumpers and strapping terminal 57 to 58. The power supply is fused by F101, whose current rating is dependent on power source voltage, in one side of the a-c line.

There are three secondary windings. The first is center-tapped, with rectification supplied by CR103-CR104. Filtering is accomplished by two sections of capacitor C149 and choke L103, and the resultant 12.6 volts d-c (+6.3 volts to -6.3 volts) is used for nuvistor filaments in the record/reproduce circuits and plug-in accessories such as the sel-sync and microphone preamplifier units.

Another secondary winding is connected to the bridge rectifier of CR105, CR106, CR107, and CR108. The rectified power is then routed in two paths. The first is filtered by two sections of capacitor C150, and resistor R165, then is connected through dropping resistors R166 and R167 to two contact sets of electronics record relay K102. When the equipment is in the record mode, this switched B+ voltage is delivered to the final stage of the output amplifier and the bias amplifier modules in the record circuit. Any output from those modules is thus dependent on the equipment being in the record mode. Note that decoupling is provided by a third section of capacitor C150. This capacitor also provides a slow buildup and decay of B+ power to prevent switching transients; the decay side of the line (K102 de-energized) is returned to the negative side of the d-c filament voltage supply to assure complete cutoff of the record circuits.

The second path from the bridge rectifier provides unswitched B+ power to all stages in the reproducing circuit, and to those stages in the recording circuit not supplied with switched B+. (Optional plug-in modules, such as the sel-sync and microphone preamplifier units, are also supplied with this B+ power.) Filtering is provided by choke L104, two sections of capacitor C102, and a fourth section of capacitor C150. Dropping resistors are R169, R172, and R177. Note that R169 is shorted by a contact set of electronics record relay K102 when the equipment is in the record mode. This acts to stabilize the voltage under the higher current conditions that exist in record.

The final power transformer secondary winding provides 6.3 volts a-c to indicator lights and to nuvistor filaments for the final stages of the output amplifier modules in both the recording and reproducing circuits.

5.5.3 Recording Amplifier

It is anticipated that the recorder will normally be used with auxiliary equipment such as a control console or mixer which will deliver a line level of -20 to +12 vu to the input of the recording amplifier. In such cases, if an unbalanced line is employed, the dummy plug (Ampex Catalog No. 4030034-10) which is supplied with the equipment is inserted in J102 at the input of the recording amplifier (see Figure 7-5). If a balanced line is used, a plug-in bridging input transformer with unity gain (Ampex Catalog No. 4580116-01), available as an optional accessory, is inserted in J102.

Socket J102 is connected so that a step-up matching transformer (Catalog No. 4580116-02) or a microphone preamplifier (Catalog Nos. 01-96440-01 with 40 db gain or 01-96440-04 with 60 db gain) can be used. These plug-in units are available as optional accessories. The matching transformer gives an approximate 14 db voltage gain, so lower line levels can be used. With the 40 db preamplifier, recording can be accomplished directly from a relatively high output microphone, having a rated output from -50 to -25 dbm (2.4 to 43 millivolts). The 60 db preamplifier allows the use of microphones having rated outputs from -70 to -35 dbm (0.23 to 13.7 millivolts). If a preamplifier is used, a 22 K resistor, connected across terminals 2 and 3 of J102 must be removed.

From whichever input unit is used, the signal proceeds through RECORD LEVEL control R103 to the grid of V101. This is a conventional feedback amplifier stage, with low output impedance achieved by the feedback through R105 and by the by-passed cathode resistance. Following V101, the signal is routed in two paths. The first leads through record calibrating resistor R121 to the cathode follower stage V102, which is used for isolation. It is then connected to output relay K101 and thence to the reproduce output amplifier in the record mode; it is there used for the A-B monitoring function and for setting record level on the vu meter.

The second path from V101 proceeds to the high frequency equalization circuits, with the applicable circuit selected by switches S101A (15 ips) and S102A (7-1/2 or 30 ips) and by the action of contact set 1-5-9 of equalization relay K103. This relay is de-energized when the 15 ips speed is selected at the tape transport, energized when the 7-1/2 or 30 ips speed (depending on the strapping in the transport for the individual recorder) is selected. High frequency equalization is achieved by parallel resistive-capacitive circuits connected in series with the signal line, with the AME (Ampex Master Equalization) circuit also having a series r-c network to ground.

Next in the signal path is the low frequency equalization circuit employed for 15 ips (either NAB or AME) and for 7-1/2 ips (NAB). This is a fixed parallel r-c circuit in series with R115 to ground. Switch S103A selects NAB/AME or CCIR equalization at 15 ips, S104A selects 7-1/2 NAB or CCIR/USA 30 ips equalization. This selection of 15 ips or 7 $\frac{1}{2}$ /30 ips is done by contact set 2-6-10 of equalization relay K103. Note that the equalization circuit is shorted to ground for CCIR 15 ips speed and for CCIR/USA 30 ips speed.

After equalization, the signal enters the recording output amplifier plug-in module (see Figures 7-5 and 7-9). Nuvistors V201 and V202 form an amplifier/phase inverter circuit that drives the conventional push-pull output stage of V203-V204.

The transformer-coupled output from the output module is taken through a bias trap consisting of C117/L101, mixed with the bias current (refer to following paragraph) and delivered to the record head through RECORD SELECTOR switch contacts when the switch is in the READY position.

The master bias oscillator is located on the tape transport (refer to Section 4 for a description of this circuit). The signal from the oscillator is connected to J104 or J105, which are paralleled to provide connection between electronic assemblies and is routed to the bias amplifier plug-in module (see Figures 7-5 and 7-8). Nuvistors V301 and V302 form a conventional push-pull amplifier with degenerative feed back provided by one secondary winding of output transformer T301 to the cathodes. A tuned output circuit is provided by another secondary winding, capacitor C305, and variable

capacitor C306. The circuit is tuned to the frequency of the bias oscillator to provide maximum level and minimum distortion. The full output of the bias amplifier module is connected to the erase head when the RECORD SELECTOR switch is in the READY position. The output is also adjusted for correct bias level at R122 and mixed with the program signal before being connected to the record head (also through contacts of the RECORD SELECTOR switch).

5.5.4 Reproducing Amplifier

A new concept in the design of the reproducing amplifier has resulted in a significant improvement in signal-to-noise and in flatness of frequency response. The circuit will first be explained in general terms, then the full description will be given.

Given constant flux, the output of a reproduce head by itself would rise with frequency at a constant 6 db per octave rate. This rise would continue until certain losses (eddy current losses, etc), in the head as the frequency rose above a certain value would overcome the upward slope of the output curve, then cause a rapidly falling head output. In a well designed reproduce head, such losses normally occur only at frequencies well above the audio passband, and so can be disregarded in this discussion.

When the reproduce head is connected to an amplifier, capacitance is introduced into the circuit. This capacitance, in conjunction with the inductance of the head coil, forms a resonant circuit. Until now, it has been the practice of design engineers to place the resonant peak outside the upper passband of the equipment. This has led to one of the traditional compromises in professional audio magnetic tape recorders--where the number of turns on the head coil (and thus the output of the head) was restricted by the inductance which would result in an acceptable resonant point. The head output into a flat amplifier thus would show the

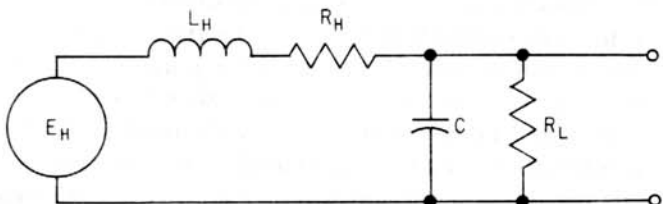

Fig. 5-2. Equivalent Circuit--Head and Input

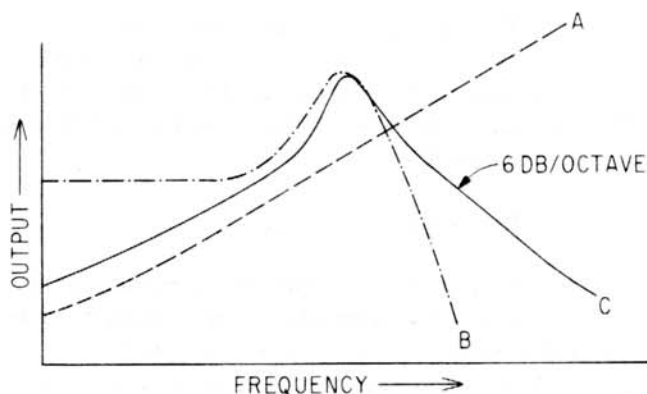

Fig. 5-3 Head Output

rising 6 db per octave slope, with a resonant peak near the upper frequency limit. The amplifier was then equalized to provide a falling 6 db per octave output and the standard post emphasis to arrive at a flat, equalized output. (This description of the design concepts which have heretofore been followed in designing a reproducing system has been greatly simplified. Basically, however, these are the principles which have been followed.)

An equivalent circuit of the reproduce head and amplifier input is given in Figure 5-2. In this illustration, the voltage output of the head (E_H) is shown working into a low pass filter consisting of the head inductance (L_H) and a capacitance (C) which can be distributed capacitance of the head winding, cable, and amplifier input. The Q of this filter is determined by the eddy current losses in the head and the resistance of the load (R_L). The output of the head itself rises 6 db per octave (curve A, Figure 5-3). Disregarding the effect of R_L , the response of the filter is indicated in curve B of Figure 5-3. Adding these two curves, the resultant output of the head is indicated by curve C of Figure 5-3.

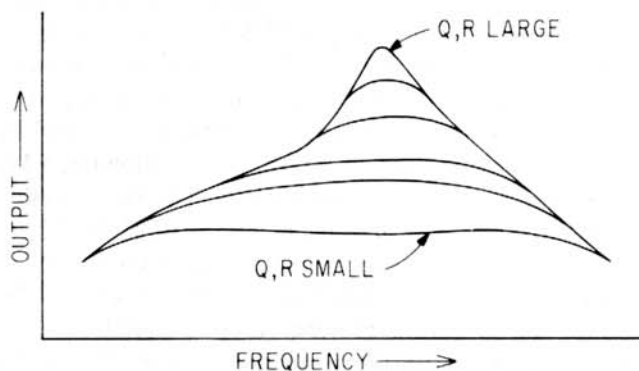

Fig. 5-4. Flattening Head Output

As shown in Figure 4-5, if R1 is small and the Q of the filter circuit is low, the resultant curve C of Figure 5-3 can be flattened to provide a relatively constant output. Instead of using a normal shunting resistor across the amplifier input--which would result in an unacceptable signal-to-noise ratio because of the high thermal noise associated with such a resistor--the same effective low input resistance can be achieved by using a high gain pre-amplifier with very heavy feedback. This creates a virtually noise-free shunting resistor at the amplifier input.

Using such a circuit, it is possible to move the head resonance point back into the audio frequency band. This in turn allows the use of higher output heads (more windings can be employed on the head coil) and a consequent increase in signal-to-noise. This is indicated in Figure 5-5, where A represents the traditional curve, with the resonant peak above the passband, and B the new curve. The shaded area represents the increased signal-to-noise that is achieved. The crossover point of the two curves is at approximately 15 kc.

In the actual circuit the response will be flat except in the low frequency region, where the head resistance causes the feedback factor to become flat in respect to frequency--which causes a 6 db per octave low frequency roll-off (curve C, Figure 5-6). Low frequency post emphasis is applied to flatten the response (curve A, Fig. 5-6), then a controlled adjustable drop is provided (curve B, Fig. 5-6) to compensate for head bump phenomena. The standard high frequency post emphasis (NAB or CCIR) is also added, so the resultant constant flux response appears as in curve B-D of Fig. 5-6.

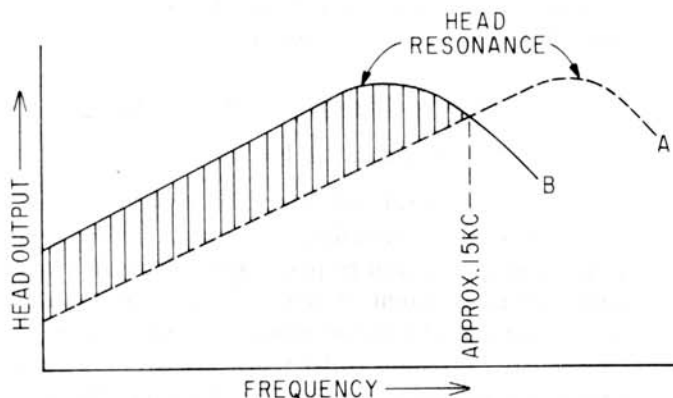

Fig. 5-5 Result of Moving Head Resonance

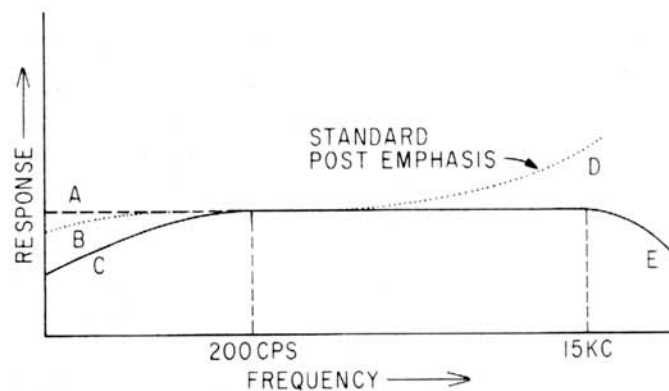

Fig. 5-6. Final Response

The overall schematic diagram of the reproduce circuit is shown on Figure 7-6. The reproduce head is connected to J110 and its output is coupled through transformer T101 to the grid of nuvistor V103 (it is impossible to wind enough turns on a multi-channel reproduce head to eliminate this transformer). Nuvistors V103, V104, and V105, form a high gain preamplifier circuit with negligible phase shift, employing a grounded cathode, grounded plate, and grounded grid circuit respectively. The output at the plate of V105 is routed through a very low frequency attenuation circuit (R136-C120) and C122. Feedback through resistor R137 to the grid of V103 provides approximately 60 db damping at the resonant frequency of the head, thus providing the noise-free input resistance previously described in general terms. CR101 protects V104 so that, during power turn-on, the grid of the nuvistor will not go positive in respect to the cathode.

From C122, the signal proceeds through REPRODUCE LEVEL control R133 and C123 to the grid of V106. High frequency equalization (boost) is provided in the cathode circuit of this stage. Switch S101B selects NAB, CCIR, or AME 15 ips equalization, while S102B selects 7-1/2 NAB/30 CCIR, 7-1/2 CCIR, or 30 USA equalization. Relay K103 (equalization) selects the 15 ips circuits when de-energized, the 7-1/2 and 30 ips circuits when energized. Note in the plate circuit of V106 that capacitor C125 is connected in parallel with coupling capacitor C124 for CCIR 7-1/2 or 15 ips and USA 30 ips equalization, by the action of relay K104 and switches S103B and S104B. This is required to maintain flat low frequency response, since no record pre-emphasis is employed for these types of equalization. (The required low frequency droop for NAB equalization is achieved

by switching C125 out of the circuit.) Decoupling is provided by two sections of C118 in conjunction with R140 and R139.

The signal is next connected to the grid of stage V107. A controlled low frequency boost circuit, adjustable to provide flat response, is provided by a feedback network between the plate and grid. Any or all of three capacitors--C129, C130, and C131--may be strapped into the circuit in any combination to provide a fairly wide frequency range. Variable capacitor C128 is then adjusted to give the boost at the required frequency. Resistor R147 and capacitor C126 form a shelving circuit, limiting the boost applied to a predetermined level. C128 thus selects the upper frequency at which the boost occurs (which can vary from approximately 120 cps to 40 cps) while the amount of the boost is determined by the shelving circuit.

From V107 the signal is routed to a circuit which provides a high frequency gap loss adjustment. Gap loss occurs at high frequencies when the wavelength of the signal recorded on the tape approaches the dimension of the reproduce head gap. As this point approaches, the response rolls off--slowly at first then very rapidly to practically zero output when the wave length equals the gap length. (Heads with very short gap lengths can be manufactured, but the result is either lower output or reduced head life.) The compensating circuit consists of a resonant circuit formed by inductor L102 in series to ground with variable capacitor C140 (15 ips) or C141 (7-1/2 or 30 ips) as selected by contacts of relay K103. The Q of this circuit, determined by R150 and the plate circuit impedance of V107, is designed so that a boost is provided immediately before resonance that is the mirror image of the initial roll-off caused by gap loss. This effect and the consequent extended flat response is shown in Figure 5-7.

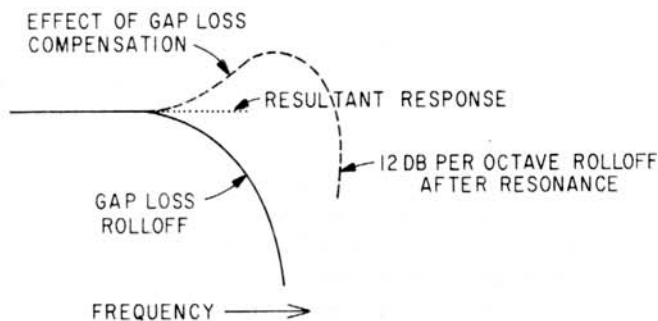

Fig. 5-7. Head Gap Compensation

Note that this adjustment is solely for the head and tape speed employed--it has no relation to the type of tape or the equalization standard.

After gap loss compensation, the signal is connected to the grid of cathode follower stage V108 (CR102 protects the grid of this stage). Low frequency equalization, adjustable to compensate for low frequency head bumps, is provided at the output of this stage. Equalization for 15 ips or $7\frac{1}{2}/30$ ips is selected by contacts of relay K104, and the equalization is achieved by adjusting the r-c time constant of C142 and R154/R156 or R155/R157 to ground to provide the desired low frequency attenuation. From V108 the signal is routed through a 14 db attenuation pad (R186-R187) built into dummy plug P111 at the electronics remote control connector (this pad can be replaced by a 20 K remote control, if desired).

The signal then is connected to contacts of relay K104 and selector switch S101C and S101D. These relay contacts and switches route the signal straight through (NAB or CCIR equalization) or connect it to an AME high frequency equalization circuit, adjustable to put the response on the AME curve.

Contacts of output relay K101 select the reproduced signal (de-energized) or the input signal (energized). In either the READY or SAFE position of the RECORD SELECTOR switch, the selected signal is fed to the input of another output amplifier module identical to that in the record circuit (refer to paragraph 5.5.3). The output is delivered to OUTPUT connector J114, the meter circuit, and phones connector J115. Strapping on the latter line allows the vu meter to indicate O at either a +4 or +8 vu output level. If the equipment is to drive a 150-ohm line, rather than a 600 ohm, the 560-ohm resistor R179 should be changed to a 150-ohm, $\pm 10\%$, $\frac{1}{2}$ watt resistor.

5.5.5 Optional Sel Sync* Preamplifier

5.5.5.1 Development of Sel Sync

Les Paul and Mary Ford pioneered the sound-on-sound recording technique, which consists of adding parts to previously recorded parts until one instrument or one voice can be made to appear as a multi-instrument or choral group. Originally, a single (full) track recorder was used--with a special head arrangement where the tape passed the playback, erase, and record heads, in

*TM, Ampex Corporation

that order. The first part was recorded normally, then the tape was rewound to the beginning of the recording. The output of the reproduce amplifier was then connected to a headset for monitoring, and also paralleled with the microphone to the input of the recording circuit. To record the second part, the equipment was started in the record mode. The tape passed the playback head where the first part was reproduced and routed to the monitor headset and the record input, then was erased by the erase head. The second part was played (or sung) in synchronism with the first and the two parts were mixed at the record input and recorded on the tape as it passed the record head. This process was repeated until all parts were recorded on the one track. The major problem was that a mistake during any recording run spoiled all previous recordings and it was necessary to start afresh at the very beginning.

The use of two recorders, or a stereophonic recorder, overcame this difficulty. The first part was recorded on one recorder, or track. The playback output from that recorder was both monitored and mixed with the microphone input at the record input of the second recorder or track. The first and second parts were then mixed on the second recorder and track. The process was then repeated until all parts were recorded, and since the preceding parts were not erased nor subsequent parts directly superimposed on them, a mistake meant only that the recording of the last part need be repeated. Note however that the process involved copying parts time after time--for example, when the second part was recorded, the first part was a first generation copy, when the third part was recorded the first part was a second generation copy and the second part was a first generation copy, etc. Degradation of recording quality is bound to occur under these circumstances--for example, a frequency response deviation of 1/2 db on the original can become 1 db on the first copy, 1-1/2 db on the second, 2 db on the third, etc. The signal-to-noise ratio will also decrease as tape noise on the original is added to that on the first copy, and the accumulated noise is added to that on the second copy, etc. (Noise increases on a "square root of the sum of the squares" basis.)

To allow better sound-on-sound, Ampex developed a self synchronization technique, known by the copyright name of Sel-Sync, for use with multi-channel recorders. Sel-Sync allows separate recording of all tracks on the tape, without

copying or superimposing one recording on the other, in perfect synchronism.

Record and reproduce heads are basically the same, and the record head can act as a fairly efficient reproduce head. The Sel-Sync technique consists of recording the first track, then switching the record head on that track so that it acts as a reproduce head for monitoring purposes. The second track can then be recorded separately, by a record head in the same stack as the first, in perfect synchronism. All tracks available on the tape can thus be recorded in synchronism with all other tracks, with no copying or superimposing of one on the other. (As many as eight tracks are provided on one-inch transports.)

After all tracks are used, if the recording of more parts is required, all tracks on the first tape can be mixed together and copied on one track of a second recorder. The same sequence of recording can then proceed on that tape. On eight channel (one inch tape) equipments, therefore, as many as 15 parts can be recorded with only one (first generation) copy involved. Since all tracks are recorded separately, a mistake on one part does not affect any previous recordings. Also, maintaining proper balance between parts becomes a function of the mixing process, rather than of the original recording process.

5.5.5.2 Sel-Sync Circuit Description

The Sel-Sync preamplifier unit plugs into an octal socket on the electronic assembly. Generally, the sel-sync operation consists of transferring the record head on pre-recorded channels to the reproduce circuitry, where the signal on those tracks can be monitored. Then another track, using a record head in the same stack as that which is being used to reproduce, can be recorded in perfect synchronism with the pre-recording.

As shown on the schematic diagram of the record circuit (see Fig. 7-5), when the RECORD SELECTOR switch is placed in the SYNC position the record head connector for that channel is transferred to the optional Sel Sync preamplifier, which plugs into an octal socket on the electronics assemblies. That record head will now act as a reproduce head, feeding the preamplifier. Filament and B+ voltage for the preamplifier, is provided by the electronics power supply. The preamplifier circuit (see Figure 8-11) consists of a

transformer-coupled input feeding a conventional two stage amplifier. Feedback is provided from the plate of the second stage to the cathode of the first to provide fixed equalization (the signal will be used only for monitoring, so no equalization adjustment is required).

The preamplifier output is routed through a calibration potentiometer (R125--see Fig. 8-5) then is connected to the reproduce output amplifier module through another contact set of the RECORD SELECTOR. It can be monitored at the output or phones connector and another track can be recorded in perfect synchronization.

5.5.6 Optional Microphone Preamplifier

As previously described (paragraph 5.5.3) if it is desired to record directly from a microphone without using a mixer or control console to provide preamplification, either of two plug-in microphone preamplifiers are available. These units are inserted in octal socket J102 on the electronic assembly.

One preamplifier provides 60 db gain through a conventional two stage amplifying circuit (see Fig. 7-13). It is designed for use with microphones rated from 170 to -35 dbm (0.23 to 13.7 millivolts). The other uses a single stage of amplification (see Fig. 7-12), to provide 40 db gain for relatively high output microphone rated from -50 to -25 dbm (2.4 to 43 millivolts).

Filament and B+ voltage is provided by the electronics power supply as indicated on the schematic diagram for the record circuit (see Figure 7-5).

NOTE

If either microphone preamplifier is used, resistor R101--connected across the output pins on the octal socket--should be removed. The purpose of this resistor is to ensure flat response when the bridging or matching transformers (also optional accessories) are used.

HEAD ASSEMBLY

6.1 GENERAL

A standard head assembly consists of three separate stacks--one for erasing, one for recording, and one for reproducing. All stacks contain individual heads for each track on the tape, with every head designed for its specific function in the system.

Equipment for 1/4-inch or 1/2-inch tape is available with two types of head assemblies. On one type, all head stacks are fixed to precise tolerances and no adjustments are required or provided. On the other type, the reproduce head stack can be adjusted to ensure the finest reproduction of master tapes recorded on other equipment. Fixed heads only are available for equipment using one-inch tape.

Procedures for adjusting reproduce head azimuth (where possible) are included as part of the Reproduce Alignment procedure described in Section 5.

6.2 MAINTENANCE OF HEAD ASSEMBLIES

6.2.1 Cleaning

Oxide from the magnetic tape will be deposited on the head assembly, and must be removed if the equipment is to operate to high standards. Heads, tape guides, and other components in the tape threading path, should be cleaned after each eight hour operating period, or oftener if visual inspection so indicates.

CAUTION

Use only the recommended solvent to clean the heads, as some will damage these precise assemblies. Do not let the solution drip or spray on plastic finishes or parts, or on the tire of the capstan idler. Also, do not use metal tools which might scratch the head assembly.

Step 1: Fully open the head gate.

Step 2: Moisten a cotton swab on a small stick (Q-tip) with Ampex Head Cleaner, Catalog No. 01-0823 or 087-004, which consists of Xylene and 0.1% Aerosol. Clean each head.

Step 3: Clean the tape guiding elements, the capstan, and the capstan idler with denatured alcohol.

NOTE

The head cleaning solution can be used to clean all metallic components (not the capstan idler) if excessive oxide deposits are encountered.

6.2.2 Demagnetizing

Heads occasionally acquire a degree of permanent magnetization which can result in increased noise and distortion and the partial erasure

of high frequency signals on recorded tapes. Demagnetize the heads after each eight hour operating period. This is easily accomplished using an Ampex Head Demagnetizer, Catalog No. 01-0820.

Step 1: Turn power off and remove any tape that is on or near the equipment (tape will be partially erased by the action of the demagnetizer).

Step 2: Cover the tips of the demagnetizer with electrician's tape (or some similar pressure sensitive tape) to prevent scratching the heads, and plug the demagnetizer into a source of 110 - 120 volt a-c power.

Step 3: Bring the tips of the demagnetizer into very light contact with the head, positioned so the tips straddle the gap in the center of the head.

Step 4: With a slow, smooth motion, run the tips up and down the stack several times. Then slowly withdraw the demagnetizer (slow withdrawal is required for effective demagnetization).

Step 5: Repeat Steps 3 and 4 at all head stacks, and at the tape guides.

Step 6: Withdraw the demagnetizer at least three feet from the recorder before unplugging it from the power source.

6.3 TRACK WIDTHS

The track widths are dependent on the width of the magnetic tape and the number of tracks to be recorded. Widths of the tracks for standard head assemblies in inches are as follows:

1/4-inch tape	Full Track	0.234
	Two Track	0.075
1/2-inch tape	Two Track	0.200
	Three Track	0.100
	Four Track	0.070
1-inch tape	Three Track	0.250
	Four Track	0.180
	Six Track	0.095
	Eight Track	0.070

PARTS LISTS AND DRAWINGS

This section provides the circuits, parts locations and parts descriptions which will enable the serviceman to properly service and repair the equipment. The reference number in the parts list refers to either the schematic reference symbol (C2, R4, etc.) or the item number on the appropriate exploded view.

The purpose of the parts list is to aid the user of Ampex equipment in obtaining replacement

parts. Ampex franchised dealers can offer the most convenient service in providing normally replaceable parts when proper information is furnished.

On occasion Ampex offers certain replacement parts that are not necessarily exact replicas of those on the original version of the equipment; but these parts are directly interchangeable with the original parts or data is provided to enable the use of the new part.

MASTER PARTS LIST
ONE CHANNEL - 1/4" TAPE - UNMOUNTED

4017011								DESCRIPTION	Ampex Part Number
-01	-02	-05	-06	-09	-10	-13	-14		
	X							RECORDER/REPRODUCER, 7½ - 15 ips, 60 cps, adj. heads	4017011-01
		X						RECORDER/REPRODUCER, 7½ - 15 ips, 50 cps, adj. heads	4017011-02
			X					RECORDER/REPRODUCER, 7½ - 15 ips, 60 cps, fixed heads	4017011-05
				X				RECORDER/REPRODUCER, 7½ - 15 ips, 50 cps, fixed heads	4017011-06
					X			RECORDER/REPRODUCER, 15 - 30 ips, 60 cps, adj. heads	4017011-09
						X		RECORDER/REPRODUCER, 15 - 30 ips, 50 cps, adj. heads	4017011-10
							X	RECORDER/REPRODUCER, 15 - 30 ips, 60 cps, fixed heads	4017011-13
							X	RECORDER/REPRODUCER, 15 - 30 ips, 50 cps, fixed heads	4017011-14
*	1		1					TRANSPORT, Tape: 7½ - 15 ips, 60 cps	4020244-01
*		1		1				TRANSPORT, Tape: 7½ - 15 ips, 50 cps	4020244-03
*					1		1	TRANSPORT, Tape: 15 - 30 ips, 60 cps	4020244-02
*						1		TRANSPORT, Tape: 15 - 30 ips, 50 cps	4020244-04
*	1	1			1	1		HEAD ASSEMBLY, Adjustable	4020236-02
*			1	1		1	1	HEAD ASSEMBLY, Fixed	4020236-01
*	1	1	1	1	1	1	1	ELECTRONIC ASSEMBLY	4020233-01
	2	2	2	2	2	2	2	KNOB, Reel hold-down	4040492-10
	2	2	2	2	2	2	2	KNOB, Reel hold-down	4100137-10
	2	2	2	2	2	2	2	KNOB, Reel editing	4030145-10
	1	1	1	1	1	1	1	CABLE ASSEMBLY, Power	4050368-01
	1	1	1	1	1	1	1	CABLE ASSEMBLY, Power interconnecting	4050365-01
	1	1	1	1	1	1	1	CABLE ASSEMBLY, Bias interconnecting	4050366-01
	1	1	1	1	1	1	1	SHIELD, Playback head connector	4600008-10
	1	1	1	1	1	1	1	CONNECTOR, Plug: signal input, Cannon XLR-3-12	145-009
	1	1	1	1	1	1	1	CONNECTOR, Plug: signal output, Cannon XLR-3-11	144-003
	1	1	1	1	1	1	1	REEL ASSEMBLY	4690003-10
	1	1	1	1	1	1	1	INSTRUCTION MANUAL	4890145-01

* See separate parts list later in this section.

MASTER PARTS LIST

ONE CHANNEL - 1/4" TAPE - CONSOLE MOUNTED

4017011								DESCRIPTION	Ampex Part Number
-03	-04	-07	-08	-11	-12	-15	-16		
	X							RECORDER/REPRODUCER, 7½ - 15 ips, 60 cps, adj. heads	4017011-03
		X						RECORDER/REPRODUCER, 7½ - 15 ips, 50 cps, adj. heads	4017011-04
			X					RECORDER/REPRODUCER, 7½ - 15 ips, 60 cps, fixed heads	4017011-07
				X				RECORDER/REPRODUCER, 7½ - 15 ips, 50 cps, fixed heads	4017011-08
					X			RECORDER/REPRODUCER, 15 - 30 ips, 60 cps, adj. heads	4017011-11
						X		RECORDER/REPRODUCER, 15 - 30 ips, 50 cps, adj. heads	4017011-12
							X	RECORDER/REPRODUCER, 15 - 30 ips, 60 cps, fixed heads	4017011-15
							X	RECORDER/REPRODUCER, 15 - 30 ips, 50 cps, fixed heads	4017011-16
*	1		1					TRANSPORT, Tape: 7½ - 15 ips, 60 cps	4020244-01
*		1		1				TRANSPORT, Tape: 7½ - 15 ips, 50 cps	4020244-03
*			1		1			TRANSPORT, Tape: 15 - 30 ips, 60 cps	4020244-02
*					1		1	TRANSPORT, Tape: 15 - 30 ips, 50 cps	4020244-04
*	1	1		1	1			HEAD ASSEMBLY, Adjustable	4020236-02
*			1	1		1	1	HEAD ASSEMBLY, Fixed	4020236-01
*	1	1	1	1	1	1	1	ELECTRONIC ASSEMBLY	4020233-01
*	1	1	1	1	1	1	1	CONSOLE ASSEMBLY	4010034-01
	2	2	2	2	2	2	2	KNOB, Reel hold-down	4040492-10
	2	2	2	2	2	2	2	KNOB, Reel hold-down	4100137-10
	2	2	2	2	2	2	2	KNOB, Reel editing	4030145-10
	1	1	1	1	1	1	1	CABLE ASSEMBLY, Power	4050368-01
	1	1	1	1	1	1	1	CABLE ASSEMBLY, Power interconnecting	4050365-01
	1	1	1	1	1	1	1	CABLE ASSEMBLY, Bias interconnecting	4050366-01
	1	1	1	1	1	1	1	SHIELD, Playback head connector	4600008-10
	1	1	1	1	1	1	1	CONNECTOR, Plug: signal input, Cannon XLR-3-12	145-009
	1	1	1	1	1	1	1	CONNECTOR, Plug: signal output, Cannon XLR-3-11	144-003
	1	1	1	1	1	1	1	REEL ASSEMBLY	4690003-10
	1	1	1	1	1	1	1	INSTRUCTION MANUAL	4890145-01

* See separate parts list later in this section.

MASTER PARTS LIST
TWO CHANNEL - 1/4" TAPE - UNMOUNTED

4017012								DESCRIPTION	Ampex Part Number
-01	-02	-05	-06	-09	-10	-13	-14		
	X							RECORDER/REPRODUCER, 7½ - 15 ips, 60 cps, adj. heads	4017012-01
		X						RECORDER/REPRODUCER, 7½ - 15 ips, 50 cps, adj. heads	4017012-02
			X					RECORDER/REPRODUCER, 7½ - 15 ips, 60 cps, fixed heads	4017012-05
				X				RECORDER/REPRODUCER, 7½ - 15 ips, 50 cps, fixed heads	4017012-06
					X			RECORDER/REPRODUCER, 15 - 30 ips, 60 cps, adj. heads	4017012-09
						X		RECORDER/REPRODUCER, 15 - 30 ips, 50 cps, adj. heads	4017012-10
							X	RECORDER/REPRODUCER, 15 - 30 ips, 60 cps, fixed heads	4017012-13
							X	RECORDER/REPRODUCER, 15 - 30 ips, 50 cps, fixed heads	4017012-14
*	1		1					TRANSPORT, Tape: 7½ - 15 ips, 60 cps	4020244-01
*		1		1				TRANSPORT, Tape: 7½ - 15 ips, 50 cps	4020244-03
*				1		1		TRANSPORT, Tape: 15 - 30 ips, 60 cps	4020244-02
*					1		1	TRANSPORT, Tape: 15 - 30 ips, 50 cps	4020244-04
*	1	1		1	1			HEAD ASSEMBLY, Adjustable	4020236-04
*			1	1		1	1	HEAD ASSEMBLY, Fixed	4020236-03
*	2	2	2	2	2	2	2	ELECTRONIC ASSEMBLY	4020233-01
	2	2	2	2	2	2	2	KNOB, Reel hold-down	4040492-10
	2	2	2	2	2	2	2	KNOB, Reel hold-down	4100137-10
	2	2	2	2	2	2	2	KNOB, Reel editing	4030145-10
	1	1	1	1	1	1	1	CABLE ASSEMBLY, Power	4050368-01
	1	1	1	1	1	1	1	CABLE ASSEMBLY, Power interconnecting	4050365-02
	1	1	1	1	1	1	1	CABLE ASSEMBLY, Bias interconnecting	4050366-01
	1	1	1	1	1	1	1	CABLE ASSEMBLY, Bias interconnecting	4050366-02
	2	2	2	2	2	2	2	SHIELD, Playback head connector	4600008-10
	2	2	2	2	2	2	2	CONNECTOR, Plug: signal input, Cannon XLR-3-12	145-009
	2	2	2	2	2	2	2	CONNECTOR, Plug: signal output, Cannon XLR-3-11	144-003
	1	1	1	1	1	1	1	REEL ASSEMBLY	4690003-10
	1	1	1	1	1	1	1	INSTRUCTION MANUAL	4890145-01

* See separate parts list later in this section.

MASTER PARTS LIST

TWO CHANNEL - 1/4" TAPE - CONSOLE MOUNTED

4017012								DESCRIPTION	Ampex Part Number
-03	-04	-07	-08	-11	-12	-15	-16		
	X							RECORDER/REPRODUCER, 7½ - 15 ips, 60 cps, adj. heads	4017012-03
		X						RECORDER/REPRODUCER, 7½ - 15 ips, 50 cps, adj. heads	4017012-04
			X					RECORDER/REPRODUCER, 7½ - 15 ips, 60 cps, fixed heads	4017012-07
				X				RECORDER/REPRODUCER, 7½ - 15 ips, 50 cps, fixed heads	4017012-08
					X			RECORDER/REPRODUCER, 15 - 30 ips, 60 cps, adj. heads	4017012-11
						X		RECORDER/REPRODUCER, 15 - 30 ips, 50 cps, adj. heads	4017012-12
							X	RECORDER/REPRODUCER, 15 - 30 ips, 60 cps, fixed heads	4017012-15
							X	RECORDER/REPRODUCER, 15 - 30 ips, 50 cps, fixed heads	4017012-16
*	1		1					TRANSPORT, Tape: 7½ - 15 ips, 60 cps	4020244-01
*		1		1				TRANSPORT, Tape: 7½ - 15 ips, 50 cps	4020244-03
*					1		1	TRANSPORT, Tape: 15 - 30 ips, 60 cps	4020244-02
*						1		TRANSPORT, Tape: 15 - 30 ips, 50 cps	4020244-04
*	1	1			1	1		HEAD ASSEMBLY, Adjustable	4020236-04
*			1	1		1	1	HEAD ASSEMBLY, Fixed	4020236-03
*	2	2	2	2	2	2	2	ELECTRONIC ASSEMBLY	4020233-01
*	1	1	1	1	1	1	1	CONSOLE ASSEMBLY	4010034-02
	2	2	2	2	2	2	2	KNOB, Reel hold-down	4040492-10
	2	2	2	2	2	2	2	KNOB, Reel hold-down	4100137-10
	2	2	2	2	2	2	2	KNOB, Reel editing	4030145-10
	1	1	1	1	1	1	1	CABLE ASSEMBLY, Power	4050368-01
	1	1	1	1	1	1	1	CABLE ASSEMBLY, Power interconnecting	4050365-02
	1	1	1	1	1	1	1	CABLE ASSEMBLY, Bias interconnecting	4050366-01
	1	1	1	1	1	1	1	CABLE ASSEMBLY, Bias interconnecting	4050366-02
	2	2	2	2	2	2	2	SHIELD, Playback head connector	4600008-10
	2	2	2	2	2	2	2	CONNECTOR, Plug: signal input, Cannon XLR-3-12	145-009
	2	2	2	2	2	2	2	CONNECTOR, Plug: signal output, Cannon XLR-3-11	144-003
	1	1	1	1	1	1	1	REEL ASSEMBLY	4690003-10
	1	1	1	1	1	1	1	INSTRUCTION MANUAL	4890145-01

* See separate parts list later in this section.

MASTER PARTS LIST

TWO CHANNEL - 1/2" TAPE - UNMOUNTED & CONSOLE MOUNTED

		4017012								DESCRIPTION	Ampex Part Number
		-17	-18	-19	-20	-21	-22	-23	-24		
	X									RECORDER/REPRODUCER, 7½ - 15 ips, 60 cps, unmounted	4017012-17
		X								RECORDER/REPRODUCER, 7½ - 15 ips, 50 cps, unmounted	4017012-18
			X							RECORDER/REPRODUCER, 7½ - 15 ips, 60 cps, console mounted	4017012-19
				X						RECORDER/REPRODUCER, 7½ - 15 ips, 50 cps, console mounted	4017012-20
					X					RECORDER/REPRODUCER, 15 - 30 ips, 60 cps, unmounted	4017012-21
						X				RECORDER/REPRODUCER, 15 - 30 ips, 50 cps, unmounted	4017012-22
							X			RECORDER/REPRODUCER, 15 - 30 ips, 60 cps, console mounted	4017012-23
								X		RECORDER/REPRODUCER, 15 - 30 ips, 50 cps, console mounted	4017012-24
*	1		1							TRANSPORT, Tape: 7½ - 15 ips, 60 cps	4020244-05
*		1		1						TRANSPORT, Tape: 7½ - 15 ips, 50 cps	4020244-07
*					1		1			TRANSPORT, Tape: 15 - 30 ips, 60 cps	4020244-06
*						1		1		TRANSPORT, Tape: 15 - 30 ips, 50 cps	4020244-08
*	1	1	1	1	1	1	1	1		HEAD ASSEMBLY, Fixed	4020236-05
*	2	2	2	2	2	2	2	2		ELECTRONIC ASSEMBLY	4020233-01
*			1	1				1	1	CONSOLE ASSEMBLY	4010034-02
	2	2	2	2	2	2	2	2	2	KNOB, Reel hold-down	4040492-10
	2	2	2	2	2	2	2	2	2	KNOB, Reel editing	4030145-10
	1	1	1	1	1	1	1	1	1	CABLE ASSEMBLY, Power	4050368-01
	1	1	1	1	1	1	1	1	1	CABLE ASSEMBLY, Power interconnecting	4050365-02
	1	1	1	1	1	1	1	1	1	CABLE ASSEMBLY, Bias interconnecting	4050366-01
	1	1	1	1	1	1	1	1	1	CABLE ASSEMBLY, Bias interconnecting	4050366-02
	2	2	2	2	2	2	2	2	2	SHIELD, Playback head connector	4600008-10
	2	2	2	2	2	2	2	2	2	CONNECTOR, Plug: signal input, Cannon XLR-3-12	145-009
	2	2	2	2	2	2	2	2	2	CONNECTOR, Plug: signal output, Cannon XLR-3-11	144-003
	1	1	1	1	1	1	1	1	1	REEL ASSEMBLY	4690003-20
	1	1	1	1	1	1	1	1	1	INSTRUCTION MANUAL	4890145-01

* See separate parts list later in this section.

MASTER PARTS LIST
THREE CHANNEL - 1/2" TAPE - UNMOUNTED

4017013									DESCRIPTION	Ampex Part Number
-01	-02	-05	-06	-09	-10	-13	-14			
	X								RECORDER/REPRODUCER, 7½ - 15 ips, 60 cps, adj. heads	4017013-01
		X							RECORDER/REPRODUCER, 7½ - 15 ips, 50 cps, adj. heads	4017013-02
			X						RECORDER/REPRODUCER, 7½ - 15 ips, 60 cps, fixed heads	4017013-05
				X					RECORDER/REPRODUCER, 7½ - 15 ips, 50 cps, fixed heads	4017013-06
					X				RECORDER/REPRODUCER, 15 - 30 ips, 60 cps, adj. heads	4017013-09
						X			RECORDER/REPRODUCER, 15 - 30 ips, 50 cps, adj. heads	4017013-10
							X		RECORDER/REPRODUCER, 15 - 30 ips, 60 cps, fixed heads	4017013-13
								X	RECORDER/REPRODUCER, 15 - 30 ips, 50 cps, fixed heads	4017013-14
*	1		1						TRANSPORT, Tape: 7½ - 15 ips, 60 cps	4020244-05
*		1		1					TRANSPORT, Tape: 7½ - 15 ips, 50 cps	4020244-07
*				1		1			TRANSPORT, Tape: 15 - 30 ips, 60 cps	4020244-06
*					1		1		TRANSPORT, Tape: 15 - 30 ips, 50 cps	4020244-08
*	1	1		1	1				HEAD ASSEMBLY, Adjustable	4020236-07
*			1	1		1	1		HEAD ASSEMBLY, Fixed	4020236-06
*	3	3	3	3	3	3	3	3	ELECTRONIC ASSEMBLY	4020233-01
	2	2	2	2	2	2	2	2	KNOB, Reel hold-down	4040492-10
	2	2	2	2	2	2	2	2	KNOB, Reel editing	4030145-10
	1	1	1	1	1	1	1	1	CABLE ASSEMBLY, Power	4050368-01
	1	1	1	1	1	1	1	1	CABLE ASSEMBLY, Power interconnecting	4050365-03
	1	1	1	1	1	1	1	1	CABLE ASSEMBLY, Bias interconnecting	4050366-01
	2	2	2	2	2	2	2	2	CABLE ASSEMBLY, Bias interconnecting	4050366-02
	3	3	3	3	3	3	3	3	SHIELD, Playback head connector	4600008-10
	3	3	3	3	3	3	3	3	CONNECTOR, Plug: signal input, Cannon XLR-3-12	145-009
	3	3	3	3	3	3	3	3	CONNECTOR, Plug: signal output, Cannon XLR-3-11	144-003
	1	1	1	1	1	1	1	1	REEL ASSEMBLY	4690003-20
	1	1	1	1	1	1	1	1	INSTRUCTION MANUAL	4890145-01

* See separate parts list later in this section.

MASTER PARTS LIST
THREE CHANNEL - 1/2" TAPE - CONSOLE MOUNTED

4017013								DESCRIPTION	Ampex Part Number
-03	-04	-07	-08	-11	-12	-15	-16		
	X							RECORDER/REPRODUCER, 7½ - 15 ips, 60 cps, adj. heads	4017013-03
		X						RECORDER/REPRODUCER, 7½ - 15 ips, 50 cps, adj. heads	4017013-04
			X					RECORDER/REPRODUCER, 7½ - 15 ips, 60 cps, fixed heads	4017013-07
				X				RECORDER/REPRODUCER, 7½ - 15 ips, 50 cps, fixed heads	4017013-08
					X			RECORDER/REPRODUCER, 15 - 30 ips, 60 cps, adj. heads	4017013-11
						X		RECORDER/REPRODUCER, 15 - 30 ips, 50 cps, adj. heads	4017013-12
							X	RECORDER/REPRODUCER, 15 - 30 ips, 60 cps, fixed heads	4017013-15
							X	RECORDER/REPRODUCER, 15 - 30 ips, 50 cps, fixed heads	4017013-16
*	1		1					TRANSPORT, Tape: 7½ - 15 ips, 60 cps	4020244-05
*		1		1				TRANSPORT, Tape: 7½ - 15 ips, 50 cps	4020244-07
*					1		1	TRANSPORT, Tape: 15 - 30 ips, 60 cps	4020244-06
*						1		TRANSPORT, Tape: 15 - 30 ips, 50 cps	4020244-08
*	1	1			1	1		HEAD ASSEMBLY, Adjustable	4020236-07
*			1	1			1	HEAD ASSEMBLY, Fixed	4020236-06
*	3	3	3	3	3	3	3	ELECTRONIC ASSEMBLY	4020233-01
*	1	1	1	1	1	1	1	CONSOLE ASSEMBLY	4010034-03
	2	2	2	2	2	2	2	KNOB, Reel hold-down	4040492-10
	2	2	2	2	2	2	2	KNOB, Reel editing	4030145-10
	1	1	1	1	1	1	1	CABLE ASSEMBLY, Power	4050368-01
	1	1	1	1	1	1	1	CABLE ASSEMBLY, Power interconnecting	4050365-03
	1	1	1	1	1	1	1	CABLE ASSEMBLY, Bias interconnecting	4050366-01
	2	2	2	2	2	2	2	CABLE ASSEMBLY, Bias interconnecting	4050366-02
	3	3	3	3	3	3	3	SHIELD, Playback head connector	4600008-10
	3	3	3	3	3	3	3	CONNECTOR, Plug: signal input, Cannon XLR-3-12	145-009
	3	3	3	3	3	3	3	CONNECTOR, Plug: signal output, Cannon XLR-3-11	144-003
	1	1	1	1	1	1	1	REEL ASSEMBLY	4690003-20
	1	1	1	1	1	1	1	INSTRUCTION MANUAL	4890145-01

* See separate parts list later in this section.

MASTER PARTS LIST
THREE CHANNEL - 1" TAPE - UNMOUNTED & CONSOLE MOUNTED

		4017013								DESCRIPTION	Ampex Part Number
		-17	-18	-19	-20	-21	-22	-23	-24		
	X		X							RECORDER/REPRODUCER, 7½ - 15 ips, 60 cps, unmounted	4017013-17
				X						RECORDER/REPRODUCER, 7½ - 15 ips, 50 cps, unmounted	4017013-18
					X					RECORDER/REPRODUCER, 7½ - 15 ips, 60 cps, console mounted	4017013-19
						X				RECORDER/REPRODUCER, 7½ - 15 ips, 50 cps, console mounted	4017013-20
							X			RECORDER/REPRODUCER, 15 - 30 ips, 60 cps, unmounted	4017013-21
								X		RECORDER/REPRODUCER, 15 - 30 ips, 50 cps, unmounted	4017013-22
									X	RECORDER/REPRODUCER, 15 - 30 ips, 60 cps, console mounted	4017013-23
									X	RECORDER/REPRODUCER, 15 - 30 ips, 50 cps, console mounted	4017013-24
*	1		1							TRANSPORT, Tape: 7½ - 15 ips, 60 cps	4020244-09
*		1		1						TRANSPORT, Tape: 7½ - 15 ips, 50 cps	4020244-11
*					1		1			TRANSPORT, Tape: 15 - 30 ips, 60 cps	4020244-10
*						1		1		TRANSPORT, Tape: 15 - 30 ips, 50 cps	4020244-12
*	1	1	1	1	1	1	1	1		HEAD ASSEMBLY, Fixed	4020236-10
*	3	3	3	3	3	3	3	3		ELECTRONIC ASSEMBLY	4020233-01
*			1	1				1	1	CONSOLE ASSEMBLY	4010034-03
	2	2	2	2	2	2	2	2		KNOB, Reel hold-down	4040492-10
	2	2	2	2	2	2	2	2		KNOB, Reel editing	4030145-10
	1	1	1	1	1	1	1	1		CABLE ASSEMBLY, Power	4050368-01
	1	1	1	1	1	1	1	1		CABLE ASSEMBLY, Power interconnecting	4050365-03
	1	1	1	1	1	1	1	1		CABLE ASSEMBLY, Bias interconnecting	4050366-01
	2	2	2	2	2	2	2	2		CABLE ASSEMBLY, Bias interconnecting	4050366-02
	3	3	3	3	3	3	3	3		SHIELD, Playback head connector	4600008-10
	3	3	3	3	3	3	3	3		CONNECTOR, Plug: signal input, Cannon XLR-3-12	145-009
	3	3	3	3	3	3	3	3		CONNECTOR, Plug: signal output, Cannon XLR-3-11	144-003
	1	1	1	1	1	1	1	1		REEL ASSEMBLY	4690003-50
	1	1	1	1	1	1	1	1		INSTRUCTION MANUAL	4890145-01

* See separate parts list later in this section.

MASTER PARTS LIST
FOUR CHANNEL - 1/2" TAPE - UNMOUNTED

		4017014								DESCRIPTION	Ampex Part Number
		-01	-02	-05	-06	-09	-10	-13	-14		
	X									RECORDER/REPRODUCER, 7½ - 15 ips, 60 cps, adj. heads	4017014-01
		X								RECORDER/REPRODUCER, 7½ - 15 ips, 50 cps, adj. heads	4017014-02
			X							RECORDER/REPRODUCER, 7½ - 15 ips, 60 cps, fixed heads	4017014-05
				X						RECORDER/REPRODUCER, 7½ - 15 ips, 50 cps, fixed heads	4017014-06
					X					RECORDER/REPRODUCER, 15 - 30 ips, 60 cps, adj. heads	4017014-09
						X				RECORDER/REPRODUCER, 15 - 30 ips, 50 cps, adj. heads	4017014-10
							X			RECORDER/REPRODUCER, 15 - 30 ips, 60 cps, fixed heads	4017014-13
								X		RECORDER/REPRODUCER, 15 - 30 ips, 50 cps, fixed heads	4017014-14
*	1		1							TRANSPORT, Tape: 7½ - 15 ips, 60 cps	4020244-05
*		1		1						TRANSPORT, Tape: 7½ - 15 ips, 50 cps	4020244-07
*					1		1			TRANSPORT, Tape: 15 - 30 ips, 60 cps	4020244-06
*						1		1		TRANSPORT, Tape: 15 - 30 ips, 50 cps	4020244-08
*	1	1			1	1				HEAD ASSEMBLY, Adjustable	4020236-09
*			1	1			1	1		HEAD ASSEMBLY, Fixed	4020236-08
*	4	4	4	4	4	4	4	4	4	ELECTRONIC ASSEMBLY	4020233-01
	2	2	2	2	2	2	2	2	2	KNOB, Reel hold-down	4040492-10
	2	2	2	2	2	2	2	2	2	KNOB, Reel editing	4030145-10
	1	1	1	1	1	1	1	1	1	CABLE ASSEMBLY, Power	4050368-01
	1	1	1	1	1	1	1	1	1	CABLE ASSEMBLY, Power interconnecting	4050365-04
	1	1	1	1	1	1	1	1	1	CABLE ASSEMBLY, Bias interconnecting	4050366-01
	3	3	3	3	3	3	3	3	3	CABLE ASSEMBLY, Bias interconnecting	4050366-02
	4	4	4	4	4	4	4	4	4	SHIELD, Playback head connector	4600008-10
	4	4	4	4	4	4	4	4	4	CONNECTOR, Plug: signal input, Cannon XLR-3-12	145-009
	4	4	4	4	4	4	4	4	4	CONNECTOR, Plug: signal output, Cannon XLR-3-11	144-003
	1	1	1	1	1	1	1	1	1	REEL ASSEMBLY	4690003-20
	1	1	1	1	1	1	1	1	1	INSTRUCTION MANUAL	4890145-01

* See separate parts list later in this section.

MASTER PARTS LIST

FOUR CHANNEL - 1/2" TAPE - CONSOLE MOUNTED

		4017014								DESCRIPTION	Ampex
		-03	-04	-07	-08	-11	-12	-15	-16		Part Number
	X									RECORDER/REPRODUCER, 7½ - 15 ips, 60 cps, adj. heads	4017014-03
		X								RECORDER/REPRODUCER, 7½ - 15 ips, 50 cps, adj. heads	4017014-04
			X							RECORDER/REPRODUCER, 7½ - 15 ips, 60 cps, fixed heads	4017014-07
				X						RECORDER/REPRODUCER, 7½ - 15 ips, 50 cps, fixed heads	4017014-08
					X					RECORDER/REPRODUCER, 15 - 30 ips, 60 cps, adj. heads	4017014-11
						X				RECORDER/REPRODUCER, 15 - 30 ips, 50 cps, adj. heads	4017014-12
							X			RECORDER/REPRODUCER, 15 - 30 ips, 60 cps, fixed heads	4017014-15
								X		RECORDER/REPRODUCER, 15 - 30 ips, 50 cps, fixed heads	4017014-16
*	1		1							TRANSPORT, Tape: 7½ - 15 ips, 60 cps	4020244-05
*		1		1						TRANSPORT, Tape: 7½ - 15 ips, 50 cps	4020244-07
*					1		1			TRANSPORT, Tape: 15 - 30 ips, 60 cps	4020244-06
*						1		1		TRANSPORT, Tape: 15 - 30 ips, 50 cps	4020244-08
*	1	1			1	1				HEAD ASSEMBLY, Adjustable	4020236-09
*			1	1			1	1		HEAD ASSEMBLY, Fixed	4020236-08
*	4	4	4	4	4	4	4	4	4	ELECTRONIC ASSEMBLY	4020233-01
*	1	1	1	1	1	1	1	1	1	CONSOLE ASSEMBLY	4010034-04
	2	2	2	2	2	2	2	2	2	KNOB, Reel Hold-down	4040492-10
	2	2	2	2	2	2	2	2	2	KNOB, Reel editing	4030145-10
	1	1	1	1	1	1	1	1	1	CABLE ASSEMBLY, Power	4050368-01
	1	1	1	1	1	1	1	1	1	CABLE ASSEMBLY, Power interconnecting	4050365-04
	1	1	1	1	1	1	1	1	1	CABLE ASSEMBLY, Bias interconnecting	4050366-01
	3	3	3	3	3	3	3	3	3	CABLE ASSEMBLY, Bias interconnecting	4050366-02
	4	4	4	4	4	4	4	4	4	SHIELD, Playback head connector	4600008-10
	4	4	4	4	4	4	4	4	4	CONNECTOR, Plug: signal input, Cannon XLR-3-12	145-009
	4	4	4	4	4	4	4	4	4	CONNECTOR, Plug: signal output, Cannon XLR-3-11	144-003
	1	1	1	1	1	1	1	1	1	REEL ASSEMBLY	4690003-20
	1	1	1	1	1	1	1	1	1	INSTRUCTION MANUAL	4890145-01

* See separate parts list later in this section.

MASTER PARTS LIST

FOUR CHANNEL - 1" TAPE - UNMOUNTED & CONSOLE MOUNTED

4017014								DESCRIPTION	Ampex Part Number
-17	-18	-19	-20	-21	-22	-23	-24		
	X							RECORDER/REPRODUCER, 7½ - 15 ips, 60 cps, unmounted	4017014-17
		X						RECORDER/REPRODUCER, 7½ - 15 ips, 50 cps, unmounted	4017014-18
			X					RECORDER/REPRODUCER, 7½ - 15 ips, 60 cps, console mounted	4017014-19
				X				RECORDER/REPRODUCER, 7½ - 15 ips, 50 cps, console mounted	4017014-20
					X			RECORDER/REPRODUCER, 15 - 30 ips, 60 cps, unmounted	4017014-21
						X		RECORDER/REPRODUCER, 15 - 30 ips, 50 cps, unmounted	4017014-22
							X	RECORDER/REPRODUCER, 15 - 30 ips, 60 cps, console mounted	4017014-23
							X	RECORDER/REPRODUCER, 15 - 30 ips, 50 cps, console mounted	4017014-24
*	1		1					TRANSPORT, Tape: 7½ - 15 ips, 60 cps	4020244-09
*		1		1				TRANSPORT, Tape: 7½ - 15 ips, 50 cps	4020244-11
*					1		1	TRANSPORT, Tape: 15 - 30 ips, 60 cps	4020244-10
*						1	1	TRANSPORT, Tape: 15 - 30 ips, 50 cps	4020244-12
*	1	1	1	1	1	1	1	HEAD ASSEMBLY, Fixed	4020236-11
*	4	4	4	4	4	4	4	ELECTRONIC ASSEMBLY	4020233-01
*			1	1			1	CONSOLE ASSEMBLY	4010034-04
	2	2	2	2	2	2	2	KNOB, Reel hold-down	4040492-10
	2	2	2	2	2	2	2	KNOB, Reel Editing	4030145-10
	1	1	1	1	1	1	1	CABLE ASSEMBLY, Power	4050368-01
	1	1	1	1	1	1	1	CABLE ASSEMBLY, Power interconnecting	4050365-04
	1	1	1	1	1	1	1	CABLE ASSEMBLY, Bias interconnecting	4050366-01
	3	3	3	3	3	3	3	CABLE ASSEMBLY, Bias interconnecting	4050366-02
	4	4	4	4	4	4	4	SHIELD, Playback head connector	4600008-10
	4	4	4	4	4	4	4	CONNECTOR, Plug: signal input, Cannon XLR-3-12	145-009
	4	4	4	4	4	4	4	CONNECTOR, Plug: signal output, Cannon XLR-3-11	144-003
	1	1	1	1	1	1	1	REEL ASSEMBLY	4690003-50
	1	1	1	1	1	1	1	INSTRUCTION MANUAL	4890145-01

* See separate parts list later in this section.

TAPE TRANSPORT - 1/4" TAPE

Ref. Sym.	4020244				DESCRIPTION	Ampex Part Number
	-01	-02	-03	-04		
P503	X				TAPE TRANSPORT, 7-1/2 - 15 ips, 60 cps	4020244-01
		X			TAPE TRANSPORT, 15 - 30 ips, 60 cps	4020244-02
			X		TAPE TRANSPORT, 7-1/2 - 15 ips, 50 cps	4020244-03
				X	TAPE TRANSPORT, 15 - 30 ips, 50 cps	4020244-04
	1				DRIVE MOTOR AND BRACKET ASSEMBLY	4030206-10
		1			DRIVE MOTOR AND BRACKET ASSEMBLY	4030206-20
			1		DRIVE MOTOR AND BRACKET ASSEMBLY	4030206-30
				1	DRIVE MOTOR AND BRACKET ASSEMBLY	4030206-40
	1				MOTOR ASSEMBLY, Drive	4030197-10
		1			MOTOR ASSEMBLY, Drive	4030197-20
			1		MOTOR ASSEMBLY, Drive	4030197-30
				1	MOTOR ASSEMBLY, Drive	4030197-40
	1				PULLEY, Drive motor	Not available
	1	1			MOTOR, Drive	Not available
	1	1	1	1	CONNECTOR, Plug: mail, 6 contact, Jones P-306-CCT	145-004
	1	1	1	1	PLATE, Drive motor mounting	4330247-01
	4	4	4	4	SCREW, Machine: flat head, Phillips drive, 10-24 by 1/2 in. lg.	471-734
	1	1	1	1	RING, Retaining: external, beveled, Truarc 5102-231-MD	430-366
	1	1	1	1	MOUNTING BRACKET ASSEMBLY, Drive motor	4030205-10
	1	1	1	1	BRACKET, Support: motor mounting	4260296-10
	1	1	1	1	BRACKET, Mounting: motor	4260299-10
	1	1	1	1	STOP, Drive motor	4220192-10
	1	1	1	1	WASHER, Lock: split ring, 1/4 in.	502-006
	1	1	1	1	SHAFT,	4210175-10
	2	2	2	2	BEARING, Ball: Fafnir A38KDD	421-083
	2	2	2	2	RING, Retaining: internal, flat, Truarc N5000-86-S-ZD	430-028
	a/r	a/r	a/r	a/r	WASHER, Shim: 0.0005 in. thk.	4440113-10
	a/r	a/r	a/r	a/r	WASHER, Shim: 0.015 in. thk.	4440113-30
	2	2	2	2	SCREW, Set: headless, socket drive, 8-32 by 1/4 in. lg.	477-041
	1	1	1	1	BEARING, Ball: Fafnir B546FS171	421-228
	4	4	4	4	SCREW, Machine: pan head, Phillips drive, 6-32 by 3/8 in. lg.	471-069
	4	4	4	4	NUT, Hex: 6-32	492-009
4	4	4	4	WASHER, Lock: external tooth, No. 6	502-014	
1	1	1	1	CAPACITOR ASSEMBLY, Motor	4050336-10	
1	1	1	1	CAPACITOR, Motor	4540292-30	
1	1	1	1	BOOT, Safety: Sprague 301-66	032-082	
2	2	2	2	CONNECTOR, Solderless: slotted ring, Amp 328394	171-360	
2	2	2	2	SCREW, Machine: pan head, Phillips drive; 10-24 by 5/8 in. lg.	471-865	
2	2	2	2	WASHER, Flat: No. 10	501-011	
2	2	2	2	WASHER, Lock: external tooth, No. 10	502-016	
1	1	1	1	ACTUATOR ASSEMBLY, Drive motor	4030204-10	
				ACTUATOR ASSEMBLY, Drive motor	4030204-20	
1	1	1	1	SOLENOID ASSEMBLY	4030202-20	
1	1	1	1	SOLENOID	4590106-10	
1	1	1	1	BOLT, Eye	4400496-90	
1	1	1	1	PIN, Clevis: 1/8 in. dia. by 17/32 in. lg.	400-009	
1	1	1	1	PIN, Cotter: 1/16 in. dia. by 1/2 in. lg.	401-005	
1	1	1	1	WASHER, Felt: 1/2 in. OD by 1/4 in. ID by 1/4 in. thk.	503-015	
1	1	1	1	STOP, Solenoid	4220139-20	
2	2	2	2	SCREW, Machine: pan head, Phillips drive, 8-32 by 1/4 in. lg.	471-076	
2	2	2	2	WASHER, Lock: external tooth, No. 8	502-068	
2	2	2	2	CONNECTOR, Solderless: slotted ring, Amp 328394	171-360	
1	1	1	1	PLATE, Solenoid adapter	4330195-10	
4	4	4	4	SCREW, Machine: flat head, Phillips drive, 8-32 by 1/4 in. lg.	471-343	
1	1	1	1	STOP, Drive motor	4220196-10	
				STOP, Drive motor	4220224-10	
1	1	1	1	ANCHOR, Motor return spring	4260295-10	
2	2	2	2	SCREW, Machine: pan head, Phillips drive, 8-32 by 1/2 in. lg.	471-080	
2	2	2	2	WASHER, Flat: No. 8	501-911	
2	2	2	2	WASHER, Lock: external tooth, No. 8	502-015	
1	1	1	1	PAD	4130150-10	
1	1	1	1	SCREW, Set: headless, socket drive, 10-32 by 3/4 in. lg.	477-340	
1	1	1	1	NUT, Hex: 10-32	492-011	
2	2	2	2	SCREW, Machine: pan head, Phillips drive, 10-24 by 5/8 in. lg.	471-865	
2	2	2	2	WASHER, Lock: external tooth, No. 10	502-016	
1	1	1	1	ANGLE, Drive motor actuator	4260294-10	
				ANGLE, Drive motor actuator	4260311-10	
				ANGLE, Drive motor actuator	4260312-10	

TAPE TRANSPORT - 1/4" TAPE (CONTINUED)

Ref. Sym.	4020244				DESCRIPTION	Ampex Part Number
	-01	-02	-03	-04		
	1	1	1	1	SCREW, Set: headless, socket drive, 1/4 - 28 by 1-3/4 in. lg.	477-339
	1	1	1	1	NUT, Hex: 1/4 - 28	492-037
	4	4	4	4	SCREW, Machine: pan head, Phillips drive, 10-24 by 5/8 in. lg.	471-865
	4	4	4	4	WASHER, Lock: external tooth, No.10	502-016
	1	1	1	1	SHIELD, Motor	4290516-10
	1	1	1	1	PAD, Shield spacer	4130166-10
	1	1	1	1	CLAMP, Shield	300-096
	2	2	2	2	MOUNT, Isolation spring	4260390-01
	3	3	3	3	SPRING, Isolation and actuator return	4270222-10
	1	1	1	1	PIN, Clevis: 1/8 in. dia. by 17.32 in. lg.	400-009
	1	1	1	1	SPRING, Actuator solenoid return	4270162-10
	1	1	1	1	NUT, Hex: self locking, 10-32	493-008
	1	1	1	1	STOP, Solenoid	4220200-10
	2	2	2	2	SCREW, Machine: pan head, Phillips drive, 8-32 by 1/4 in. lg.	471-076
	2	2	2	2	WASHER, Lock: external tooth, No.8	502-015
	1	1	1	1	WASHER, Felt: 1/2 in. OD by 1/4 in. ID by 1/4 in. thk.	503-015
	1	1	1	1	PIN, Clevis: 1/8 in. dia. by 17.32 in. lg.	400-009
	1	1	1	1	PIN, Cotter: 1/16 in. dia. by 1/2 in. lg.	401-005
	2	2	2	2	WASHER, Flat: No.4	501-008
	1	1	1	1	BOLT, Eye	4400612-10
	1	1	1	1	DRAWBAR, Capstan Solenoid	4210241 10
	2	2	2	2	PIN, Roll: stainless steel, 1/8 in. dia. by 5/8 in. lg.	406-030
K508	2	2	2	2	SOLENOID	4590063 10
	8	8	8	8	SCREW, Machine: pan head, Phillips drive, 8-32 by 1/2 in. lg.	471-080
	8	8	8	8	WASHER, Lock: external tooth, No.8	502-015
S505	1	1	1	1	SWITCH, Lever: subminiature, SPDT, Cherry E-61-10H	120-436
	1	1	1	1	INSULATOR, Switch	4170204-10
	2	2	2	2	SCREW, Machine: pan head, Phillips drive, 2-56 by 1/2 in. lg.	472-456
	2	2	2	2	WASHER, Flat: No.2	501-202
	2	2	2	2	WASHER, Lock: split ring, No.2	502-094
	1	1	1	1	STRIP, Terminal: barrier, 8 terminals, Kulka 410-8	180-453
	4	4	4	4	SCREW, Machine: pan head, Phillips drive, 2-56 by 1/2 in. lg.	472-456
	4	4	4	4	WASHER, Lock: split ring, No. 2	502-094
	6	6	6	6	CONNECTOR, Solderless: slotted ring, Amp 328394	171-360
	1	1	1	1	REEL IDLER ASSEMBLY	4030200-10
	1	1	1	1	BRAKE ASSEMBLY	4030201-10
	1	1	1	1	HOUSING, Brake	4330112-10
	1	1	1	1	BAND, Brake	4040414-10
	1	1	1	1	SPRING, Leaf: brake band	4270164-10
	2	2	2	2	SPRING, Tension: short	4270163-10
	1	1	1	1	SPRING, Tension: long	4270211-10
	1	1	1	1	BOLT, Eye	4400496-60
	2	2	2	2	NUT, Hex: 10-32	492-011
	1	1	1	1	CROSSHEAD, Brake	4330109-10
	2	2	2	2	SCREW, Machine: flat head, Phillips drive, 6-32 by 1-1/8 in. lg.	471-719
	4	4	4	4	WASHER, Finishing: No.6	506-001
	2	2	2	2	WASHER, Flat: No.6	501-009
	2	2	2	2	SPACER	4220141-10
	2	2	2	2	NUT, Hex: self locking, 6-32	493-006
	1	1	1	1	ANCHOR	4330110-10
	2	2	2	2	SCREW, Sem: pan head, Phillips drive, 6-32 by 5/16 in. lg.	475-085
	1	1	1	1	PIN, Roll: 1/8 in. dia. by 3/4 in. lg.	406-005
	2	2	2	2	LINK, Brake band	4230161-10
	4	4	4	4	SCREW, Machine: cap, socket drive, 4-40 by 3/16 in. lg.	470-007
	4	4	4	4	WASHER, Lock: split ring, No.4	502-002
	2	2	2	2	CLAMP, Band link	4330113-10
	1	1	1	1	LEVER, Brake	4230162-10
	2	2	2	2	PIN, Drivelock: 1/8 in. dia. by 1/2 in. lg.	403-008
	1	1	1	1	PIN, Clevis: 1/8 in. dia. by 9/32 in. lg.	400-002
	1	1	1	1	PIN, Cotter: 1/16 in. dia. by 1/2 in. lg.	401-005
	1	1	1	1	STOP, Solenoid	4260184-10
	2	2	2	2	SCREW, Sem: pan head, Phillips drive, 8-32 by 1/4 in. lg.	475-072
	2	2	2	2	LINK, Solenoid	4230163-10
	1	1	1	1	PIN, Clevis: 1/8 in. dia. by 15/32 in. lg.	400-007
	1	1	1	1	PIN, Cotter: 1/16 in. dia. by 1/2 in. lg.	401-005
	1	1	1	1	BRACKET, Solenoid	4260310-10
	2	2	2	2	SCREW, Sem: pan head, Phillips drive, 8-32 by 3/8 in. lg.	475-044
K510	1	1	1	1	SOLENOID	4590102-10

TAPE TRANSPORT - 1/4" TAPE (CONTINUED)

Ref. Sym.	4020244				DESCRIPTION	Ampex Part Number	
	-01	-02	-03	-04			
C522	2	2	2	2	SCREW, Sem: pan head, Phillips drive, 8-32 by 1/4 in. lg.	475-072	
	2	2	2	2	CONNECTOR, Solderless: disconnect splice	171-008	
	3	3	3	3	SCREW, Machine: pan head, Phillips drive, 6-32 by 1/2 in. lg.	471-071	
	3	3	3	3	WASHER, Lock: external tooth, No.6	502-014	
	1	1	1	1	MOTOR ASSEMBLY, Torque	4040731-10	
	1	1	1	1	PULLEY, Reel idler	4250159-10	
	1	1	1	1	SCREW, Set: headless, socket drive, 8-32 by 3/8 in. lg.	477-043	
	1	1	1	1	ADAPTER, Motor mounting	4220197-10	
	4	4	4	4	SCREW, Machine: pan head, Phillips drive, 6-32 by 1/2 in. lg.	475-034	
	4	4	4	4	WASHER, Lock: external tooth, No.8	502-014	
	1	1	1	1	DRUM, Brake	Not available	
	1	1	1	1	PIN, Roll: 3/32 in. dia. by 3/4 in. lg.	406-006	
	1	1	1	1	MOTOR, Torque	Not available	
	1	1	1	1	CAPACITOR ASSEMBLY, Motor	4050336-20	
	1	1	1	1	CAPACITOR, Motor	4540292-30	
	1	1	1	1	BOOT, Safety: Sprague 301-66	032-082	
	2	2	2	2	CONNECTOR, Solderless: disconnect splice	171-008	
	2	2	2	2	WASHER, Flat: No.8	501-010	
	P511	1	1	1	1	CONNECTOR, Plug: male, 8 contact, Jones P-308-CCT-L	145-013
	4	4	4	4	CONNECTOR, Solderless: disconnect splice	171-008	
	1	1	1	1	TAKEUP ASSEMBLY	4030226-10	
	1	1	1	1	BRAKE ASSEMBLY	4030114-20	
	1	1	1	1	HOUSING, Brake	4330112-10	
	1	1	1	1	BAND, Brake	4040414-10	
	1	1	1	1	SPRING, Leaf: brake band	4270164-10	
	2	2	2	2	SPRING, Tension: short	4270163-10	
	1	1	1	1	SPRING, Tension: long	4270178-10	
1	1	1	1	BOLT, Eye	4400496-60		
2	2	2	2	NUT, Hex: 10-32	492-011		
1	1	1	1	CROSSHEAD, Brake	4330109-10		
2	2	2	2	SCREW, Machine: flat head, Phillips drive, 6-32 by 1-3/8 in. lg.	472-890		
4	4	4	4	WASHER, Finishing: No.6	506-001		
2	2	2	2	SPACER	4220141-10		
2	2	2	2	NUT, Hex: self locking, 6-32	493-006		
1	1	1	1	ANCHOR	4330110-10		
2	2	2	2	SCREW, Sem: pan head, Phillips drive, 6-32 by 5/16 in. lg.	475-085		
1	1	1	1	PIN, Roll: 1/8 in. dia. by 7/8 in. lg.	406-042		
2	2	2	2	LINK, Brake band	4230161-10		
4	4	4	4	SCREW, Machine: cap. socket drive, 4-40 by 3/16 in. lg.	470-007		
4	4	4	4	WASHER, Lock: split ring, No.4	502-002		
2	2	2	2	CLAMP, Band link	4330113-10		
1	1	1	1	LEVER, Brake	4230162-10		
2	2	2	2	PIN, Drivelock: 1/8 in. dia. by 1/2 in. lg.	403-008		
1	1	1	1	PIN, Clevis: 1/8 in. dia. by 9/32 in. lg.	400-002		
1	1	1	1	PIN, Cotter: 1/16 in. dia. by 1/2 in. lg.	401-005		
1	1	1	1	STOP, Solenoid	4260184-10		
2	2	2	2	SCREW, Sem: pan head, Phillips drive, 8-32 by 1/4 in. lg.	475-072		
2	2	2	2	LINK, Solenoid	4230163-10		
1	1	1	1	PIN, Clevis: 1/8 in. dia. by 15/32 in. lg.	400-007		
1	1	1	1	PIN, Cotter: 1/16 in. dia. by 1/2 in. lg.	401-005		
1	1	1	1	BRACKET, Solenoid	4260183-10		
2	2	2	2	SCREW, Sem: pan head, Phillips drive, 8-32 by 3/8 in. lg.	475-044		
K512	1	1	1	1	SOLENOID	4590067-10	
2	2	2	2	SCREW, Sem: pan head, Phillips drive, 8-32 by 1/4 in. lg.	475-072		
2	2	2	2	CONNECTOR, Solderless: disconnect splice	171-008		
3	3	3	3	SCREW, Machine: pan head, Phillips drive, 6-32 by 1/2 in. lg.	471-071		
3	3	3	3	WASHER, Lock: external tooth, No.6	502-014		
1	1	1	1	CAPACITOR ASSEMBLY, Motor	4050336-20		
C524	1	1	1	1	CAPACITOR, Motor	4540290-30	
1	1	1	1	BOOT, Safety: Sprague	032-082		
2	2	2	2	CONNECTOR, Solderless: disconnect splice	171-008		
2	2	2	2	WASHER, Flat: No.8	501-010		
1	1	1	1	DRIVE PLATE, Reel: with EIA drive pins	4320128-10		
3	3	3	3	SCREW, Machine: button head, 4-40 by 3/16 in. lg.	470-382		
1	1	1	1	PAD, Turntable	4130152-10		
1	1	1	1	TURNTABLE	4250160-10		
1	1	1	1	SHIM, Turntable	4280125-10		
3	3	3	3	SCREW, Machine: button head, 8-32 by 1/2 in. lg.	470-384		

TAPE TRANSPORT - 1/4" TAPE (CONTINUED)

Ref.	4020244				DESCRIPTION	Ampex Part Number
	Svm.	-01	-02	-03		
P513	1	1	1	1	SHIELD, Motor	4290516-30
	1	1	1	1	CLAMP, Shield	300-096
	1	1	1	1	MOTOR ASSEMBLY, Torque	4040797-10
	1	1	1	1	HUB, Turntable	Not available
	1	1	1	1	PIN, Roll: 3/32 in. dia. by 3/4 in. lg.	406-006
	1	1	1	1	ADAPTER, Motor mounting	4220197-10
	4	4	4	4	SCREW, Machine: pan head, Phillips drive, 6-32 by 1/2 in. lg.	471-071
	4	4	4	4	WASHER, Lock: external tooth, No. 6	502-014
	1	1	1	1	DRUM, Brake	Not available
	1	1	1	1	PIN, Roll: 3/32 in. dia. by 3/4 in. lg.	406-006
	1	1	1	1	MOTOR, Torque	Not available
	1	1	1	1	CONNECTOR, Plug: male, 8 contact, Jones P-308-CCT-L	145-013
	4	4	4	4	CONNECTOR, Solderless: disconnect splice	171-008
	1	1	1	1	REWIND ASSEMBLY	4030227-10
	1	1	1	1	BRAKE ASSEMBLY	4030114-10
	1	1	1	1	HOUSING, Brake	4330112-10
	1	1	1	1	BAND, Brake	4040414-10
	1	1	1	1	SPRING, Leaf: brake band	4270164-10
	2	2	2	2	SPRING, Tension: short	4270163-10
	1	1	1	1	SPRING, Tension: long	4270178-10
	1	1	1	1	BOLT, Eye	4400496-60
	2	2	2	2	NUT, Hex: 10-32	492-011
	1	1	1	1	CROSSHEAD, Brake	4330109-10
	2	2	2	2	SCREW, Machine: flat head, Phillips drive, 6-32 by 1-3/8 in. lg.	472-890
	4	4	4	4	WASHER, Finishing: No. 6	506-001
	2	2	2	2	SPACER	4220141-10
	2	2	2	2	NUT, Hex: self locking, 6-32	493-006
	1	1	1	1	ANCHOR	4330110-10
	2	2	2	2	SCREW, Sem: pan head, Phillips drive, 6-32 by 5/16 in. lg.	475-085
	1	1	1	1	PIN, Roll: 1/8 in. dia. by 7/8 in. lg.	406-042
	2	2	2	2	LINK, Brake band	4230161-10
	4	4	4	4	SCREW, Machine: cap, socket drive, 4-40 by 3/16 in. lg.	470-007
	4	4	4	4	WASHER, Lock: split ring, No. 4	502-002
	2	2	2	2	CLAMP, Band link	4330113-10
	1	1	1	1	LEVER, Brake	4230162-10
	2	2	2	2	PIN, Drivelock: 1/8 in. dia. by 1/2 in. lg.	403-008
	1	1	1	1	PIN, Clevis: 1/8 in. dia. by 9/32 in. lg.	400-002
	1	1	1	1	PIN, Cotter: 1/16 in. dia. by 1/2 in. lg.	401-005
	1	1	1	1	STOP, Solenoid	4260184-10
	2	2	2	2	SCREW, Sem: pan head, Phillips drive, 8-32 by 1/4 in. lg.	475-072
	2	2	2	2	LINK, Solenoid	4230163-10
	1	1	1	1	PIN, Clevis: 1/8 in. dia. by 15/32 in. lg.	400-007
	1	1	1	1	PIN, Cotter: 1/16 in. dia. by 1/2 in. lg.	401-005
	1	1	1	1	BRACKET, Solenoid	4260183-10
	2	2	2	2	SCREW, Sem: pan head, Phillips drive, 8-32 by 3/8 in. lg.	475-044
	1	1	1	1	SOLENOID	4590067-10
	2	2	2	2	SCREW, Sem: pan head, Phillips drive, 8-32 by 1/4 in. lg.	475-072
	2	2	2	2	CONNECTOR, Solderless: disconnect splice	171-008
3	3	3	3	SCREW, Machine: pan head, Phillips drive, 6-32 by 1/2 in. lg.	471-071	
3	3	3	3	WASHER, Lock: external tooth, No. 6	502-014	
1	1	1	1	CAPACITOR ASSEMBLY, Motor	4050336-20	
1	1	1	1	CAPACITOR, Motor	4540292-30	
1	1	1	1	BOOT, Safety: Sprague	032-082	
2	2	2	2	CONNECTOR, Solderless: disconnect splice	171-008	
2	2	2	2	WASHER, Flat: No. 8	501-010	
1	1	1	1	DRIVE PLATE, Reel: with EIA drive pins	4320128-10	
3	3	3	3	SCREW, Machine: button head, 4-40 by 3/16 in. lg.	470-382	
1	1	1	1	PAD, Turntable	4130152-10	
1	1	1	1	TURNTABLE	4250160-10	
1	1	1	1	SHIM, Turntable	4280125-10	
3	3	3	3	SCREW, Machine: button head, 8-32 by 1/2 in. lg.	470-384	
1	1	1	1	SHIELD, Motor	4290516-30	
1	1	1	1	CLAMP, Shield	300-096	
1	1	1	1	MOTOR ASSEMBLY, Torque	4040797-10	
1	1	1	1	HUMB, Turntable	Not available	
1	1	1	1	PIN, Roll: 3/32 in. dia. by 3/4 in. lg.	406-006	
1	1	1	1	ADAPTER, Motor mounting	4220197-10	
4	4	4	4	SCREW, Machine: pan head, Phillips drive, 6-32 by 1/2 in. lg.	471-071	

TAPE TRANSPORT - 1/4" TAPE (CONTINUED)

Ref. Sym.	4020244				DESCRIPTION	Ampex Part Number
	-01	-02	-03	-04		
P512	4	4	4	4	WASHER, Lock: external tooth, No.6	502-614
	1	1	1	1	DRUM, Brake	Not available
	1	1	1	1	PIN, Roll: 3/32 in. dia. by 3/4 in. lg.	406-006
	1	1	1	1	MOTOR, Torque	Not available
	1	1	1	1	CONNECTOR, Plug: male, 8 contact, Jones P-308-CCT-L	145-013
	4	4	4	4	CONNECTOR, Solderless: disconnect splice	171-008
	1	1	1	1	FLYWHEEL ASSEMBLY, Damped	4030196-10
	1	1	1	1	CAP, Capstan	4100167-10
	1	1	1	1	SCREW, Set: headless, socket drive, 8-32 by 1/8 in. lg.	477-348
	1	1	1	1	CAPSTAN ASSEMBLY	4030199-10
	1	1	1	1	FLYWHEEL	Not available
	1	1	1	1	PIN, Roll: 5/32 in. dia. by 1-1/4 in. lg.	406-007
	a/r	a/r	a/r	a/r	WASHER, Shim: 0.625 in. OD by 0.500 in. ID by 0.003 in. thk.	501-050
	1	1	1	1	SEAL, Dust	4440247-10
	1	1	1	1	RING, Retaining: internal, bowed, Truarc 5001-125-S	430-064
	1	1	1	1	BEARING, Ball	Not available
	1	1	1	1	SHAFT, Capstan	Not available
	1	1	1	1	HOUSING ASSEMBLY, Capstan	Not available
	1	1	1	1	IDLER ASSEMBLY, Capstan	4030203-10
	1	1	1	1	CAP, Capstan idler	4100166-10
	1	1	1	1	RING, Lock	4320112-10
	1	1	1	1	RING, Retaining: external, Flat, Truarc 5100-25-S	430-004
	a/r	a/r	a/r	a/r	WASHER, Shim: 0.437 in. OD by 0.250 in. ID by 0.002 in. thk.	501-049
	1	1	1	1	WASHER, Felt	4440239-10
	1	1	1	1	SHAFT, Capstan idler	Not available
	1	1	1	1	WASHER, Thrust	4440027-10
	1	1	1	1	WHEEL ASSEMBLY, Capstan idler	4040404-10
	1	1	1	1	SCREW, Set: headless, socket drive, 8-32 by 1/8 in. lg.	477-348
	1	1	1	1	POST ASSEMBLY, Tape turnaround	4040741-10
	1	1	1	1	SCREW, Set: headless, socket drive, 8-32 by 1/8 in. lg.	477-348
	1	1	1	1	NUT, Hex: self lock, 10-32	493-008
	1	1	1	1	SPRING, Solenoid pressure: capstan idler	4270162-10
	1	1	1	1	SPRING, Solenoid return: capstan idler	4270229-10
	1	1	1	1	ARM, Solenoid: capstan idler	4230212-10
	1	1	1	1	PIN, Roll: 1/8 in. dia. by 3/4 in. lg.	406-005
	1	1	1	1	ARM, Capstan idler	4230204-10
	1	1	1	1	BEARING, Capstan idler	Not available
	3	3	3	3	SCREW, Machine: cap, socket drive, 8-32 by 1/2 in. lg.	470-029
	1	1	1	1	DAMPER ASSEMBLY, Capstan idler	4040851-10
	1	1	1	1	SPRING, Dashpot arm	4270238-10
	1	1	1	1	PIN, Clevis: 1/8 in. dia. by 9/32 in. lg.	400-002
	1	1	1	1	HOLDDOWN, Dashpot arm	4600142-10
	1	1	1	1	SCREW, Machine: pan head, Phillips drive, 6-32 by 3/16 in. lg.	471-066
	1	1	1	1	WASHER, Lock: external tooth, No.6	502-014
	1	1	1	1	DASHPOT	4130157-20
	1	1	1	1	STOP, Dashpot arm	4220223-10
	1	1	1	1	SCREW, Machine: pan head, Phillips drive, 6-32 by 3/16 in. lg.	471-066
	1	1	1	1	WASHER, Lock: external tooth, No.6	502-014
	1	1	1	1	ARM ASSEMBLY, Dashpot	4030234-10
	1	1	1	1	SCREW, Shoulder	474-315
	1	1	1	1	PLATE ASSEMBLY, Damper mounting	4040852-10
	4	4	4	4	SCREW, Machine: pan head, Phillips drive, 6-32 by 3/8 in. lg.	471-069
	4	4	4	4	WASHER, Flat: No.6	501-009
	4	4	4	4	WASHER, Lock: external tooth, No.6	502-014
	1	1	1	1	ARM ASSEMBLY, Takeup tension	4030216-30
	1	1	1	1	TOP, Takeup tension arm	4250180-10
	1	1	1	1	SCREW, Machine: flat head, socket drive, 4-40 by 3/8 in. lg.	471-490
	1	1	1	1	ARM SUBASSEMBLY, Takeup tension	4040774-10
	1	1	1	1	SCREW, Set: headless, socket drive, 6-32 by 3/8 in. lg.	477-347
	1	1	1	1	GUIDE, Tape	4210183-20
	1	1	1	1	END, Takeup tension arm	4330196-10
	1	1	1	1	SCREW, Machine: pan head, Phillips drive, 4-40 by 5/8 in. lg.	471-065
	1	1	1	1	WASHER, Lock: external tooth, No.4	502-013
	1	1	1	1	SPRING, Takeup tension arm	4270228-10
	1	1	1	1	COVER, Slot: takeup tension arm	4290523-10
	1	1	1	1	PIN, Roll: 3/32 in. dia. by 5/8 in. lg.	406-002
	1	1	1	1	SCREW, Nylon: fillister head, Phillips drive, 4-40 by 3/4 in. lg.	471-836
	1	1	1	1	RING, Retaining: grip, Truarc 5555-31-S	430-117

TAPE TRANSPORT - 1/4" TAPE (CONTINUED)

Ref. Sym.	4020244				DESCRIPTION	Ampex Part Number
	-01	-02	-03	-04		
K509	1	1	1	1	RING, Retaining: external, Flat, Truarc 5100-31-S-ZD	430-007
	1	1	1	1	WASHER, Shim: 15.32 in. OD by 21/64 in. ID by 0.0005 in. thk.	501-053
	1	1	1	1	SHAFT, Takeup tension	4210273-10
	1	1	1	1	SCREW, Set: headless, sodket drive, 10-32 by 1/4 in. lg.	477-118
	1	1	1	1	SPRING, Stop	4270227-10
	1	1	1	1	PIN, Roll: 3/32 in. dia. by 1 in. lg.	406-012
	1	1	1	1	HOUSING ASSEMBLY, Takeup arm	4030215-10
	2	2	2	2	BEARING, Bronze	423-019
	1	1	1	1	HOUSING	4290522-10
	2	2	2	2	SCREW, Machine: flat head, Phillips drive, 4-40 by 3/8 in. lg.	471-328
	1	1	1	1	ARM ASSEMBLY, Tape lifter	4040713-10
	2	2	2	2	PAD	4130150-10
	1	1	1	1	BEARING, Bronze	423-083
	1	1	1	1	ARM	4230199-10
	1	1	1	1	SCREW, Shoulder	474-313
	1	1	1	1	SPRING, Solenoid pressure: tape lifter	4270231-10
	1	1	1	1	SPRING, Solenoid return: tape lifter	4270176-10
	1	1	1	1	NUT, Hex: self locking, 10-32	493-008
	1	1	1	1	SOLENOID ASSEMBLY	4030202-10
	1	1	1	1	SOLENOID	4590106-10
	1	1	1	1	BOLT, Eye	4400604-10
	1	1	1	1	PIN, Clevis: 1/8 in. dia. by 17/32 in. lg.	400-009
	1	1	1	1	PIN, Cotter: 1/16 in. dia. by 1/2 in. lg.	401-005
	1	1	1	1	WASHER, Felt: 1/2 in. OD by 1/4 in. ID by 1/4 in. thk.	503-015
	1	1	1	1	STOP, Solenoid	4220139-20
	2	2	2	2	SCREW, Machine: pan head, Phillips drive, 8-32 by 1/4 in. lg.	471-076
	2	2	2	2	WASHER, Lock: external tooth, No.8	502-068
	2	2	2	2	CONNECTOR, Solderless: disconnect splice	171-008
	2	2	2	2	SCREW, Machine: pan head, Phillips drive, 10-24 by 3/8 in. lg.	472-415
	2	2	2	2	WASHER, Flat: No.10	501-011
	2	2	2	2	WASHER, Lock: external tooth, No.10	502-016
	1	1	1	1	ESCUTCHEON, Reel: right	4110245-10
	1	1	1	1	ESCUTCHEON, Reel: left	4110245-20
	8	8	8	8	SCREW, Reel escutcheon	4400611-10
	1	1	1	1	RESISTOR BOX ASSEMBLY, Tension control	Not available
	1	1	1	1	COVER, Resistor box	4290506-10
	4	4	4	4	SCREW, Self-tapping: pan head, Phillips drive, #6 by 1/4 in. lg.	476-011
	R515	1	1	1	RESISTOR, Fixed: wirewound, tapped, 38 ohms	4510423-10
	R516	1	1	1	RESISTOR, Fixed: wirewound, tapped, 46 ohms	4510424-10
	R517	1	1	1	RESISTOR, Fixed: wirewound, tapped, 122 ohms	4510425-10
	3	3	3	STUD, Resistor mounting	4210283-10	
	9	9	9	NUT, Kep: 8-32	496-001	
	6	6	6	WASHER, Insulating	503-007	
	6	6	6	WASHER, Centering	506-003	
R518	1	1	1	RESISTOR, Fixed: composition, 330 ohms, ±10%, 1/2 W, RC20GF331K	041-042	
	1	1	1	TIEPOINT, Solder lug: 3 terminals, Permonite 8020-3	180-240	
J510	1	1	1	CONNECTOR, Receptacle: male, 4 contact, Jones P-304-AB	147-036	
	2	2	2	SCREW, Sem: pan head, slot drive, 6-32 by 5/16 in. lg.	475-066	
	2	2	2	NUT, Kep: 6-32	496-005	
J514	1	1	1	CONNECTOR, Plug: female, 14 contact, Electric Regulator 300.105-21	144-297	
	13	13	13	CONNECTOR, Solderless: Electric Regulator 71.25-2-2	169-572	
	1	1	1	GROMMET, Elastic: MS-35489-8	260-020	
	1	1	1	BRACKET, Resistor Box	4260327-10	
	4	4	4	SCREW, Machine: pan head, Phillips drive, 10-24 by 3/8 in. lg.	472-415	
	4	4	4	WASHER, Lock: external tooth, No.10	502-016	
	1	1	1	TENSION CONTROL ASSEMBLY	4040817-10	
	1	1	1	POST, Sensing	4210278-10	
	1	1	1	PLUG, Sensing post	4100155-10	
	1	1	1	SCREW, Machine: pan head, Phillips drive, 6-32 by 5/16 in. lg.	471-068	
	1	1	1	ARM, Tension control	4230227-10	
	1	1	1	SCREW, Machine: pan head, Phillips drive, 6-32 by 5/16 in. lg.	471-068	
	2	2	2	STOP, Tension arm	4220221-10	
	2	2	2	SCREW, Machine: pan head, Phillips drive, 4-40 by 3/16 in. lg.	471-063	
P514	1	1	1	SWITCH, Tension control	4620178-10	
	1	1	1	YOKE, Actuator	4230210-10	
	1	1	1	SLIDE, Actuator	4210280-10	
	4	4	4	SCREW, Machine: pan head, Phillips drive, 6-32 by 5/16 in. lg.	471-068	
	1	1	1	SPRING, Return	4270234-10	

TAPE TRANSPORT - 1/4" TAPE (CONTINUED)

Ref. Sym.	4020244				DESCRIPTION	Ampex Part Number
	-01	-02	-03	-04		
1	1	1	1	1	DASHPOT, Tension control	4130157-10
1	1	1	1	1	BRACKET, Dashpot mounting	4260363-10
2	2	2	2	2	SCREW, Machine: pan head, Phillips drive, 6-32 by 5/16 in. lg.	471-068
1	1	1	1	1	TIMING BLOCK ASSEMBLY	4040821-10
1	1	1	1	1	SPRING, Timing adjustment	4270235-10
1	1	1	1	1	COUNTERBALANCE	4220220-10
1	1	1	1	1	NUT, Hex: 4-40	492-008
1	1	1	1	1	SCREW, Machine: cap head, socket drive, 4-40 by 5/8 in. lg.	470-013
1	1	1	1	1	WASHER, Flat: No.4	501-008
1	1	1	1	1	BRACKET, Dashpot actuating	4260362-10
1	1	1	1	1	SCREW, Machine: pan head, Phillips drive, 4-40 by 3/8 in. lg.	471-062
1	1	1	1	1	BLOCK, Adjusting	4220218-10
1	1	1	1	1	SCREW, Set: headless, socket drive, 4-40 by 1/4 in. lg.	477-031
1	1	1	1	1	SCREW, Machine: flat head, Phillips drive, 4-40 by 1/4 in. lg.	471-326
1	1	1	1	1	RING, Retaining: grip, Truarc 555-31-S	430-117
1	1	1	1	1	HUB, Tension arm	Not available
2	2	2	2	2	SCREW, Set: headless, socket drive, 4-40 by 1/4 in. lg.	477-031
1	1	1	1	1	WASHER, Shim: 0.010 in. thk.	4440113-20
1	1	1	1	1	SHAFT, Tension control	Not available
2	2	2	2	2	BEARING, Ball: Fafnir RM38KOD, FS30171	421-110
2	2	2	2	2	RING, Retaining: internal, flat, Truarc N5000-86-S	430-027
1	1	1	1	1	HOUSING, Tension control	Not available
3	3	3	3	3	SCREW, Machine: pan head, Phillips drive, 10-24 by 3/4 in. lg.	472-418
3	3	3	3	3	WASHER, Lock: external tooth, No.10	502-016
1	1	1	1	1	ESCUTCHEON ASSEMBLY, Power and speed control	4040719-10
	1			1	ESCUTCHEON ASSEMBLY, Power and speed control	4040719-20
2	2	2	2	2	PIN, Roll: 1/16 in. dia. by 3/8 in. lg.	406-022
2	2	2	2	2	BALL, 5/32 in. dia.	420-998
2	2	2	2	2	SPRING, Actuator	4270236-10
2	2	2	2	2	ACTUATOR, Switch	4230202-10
1	1	1	1	1	PIN, Power and speed switch actuator	4210247-10
2	2	2	2	2	RING, Retaining: external, "E", Truarc 5144-9-MO	430-343
2	2	2	2	2	ACTUATOR, Power and speed switch	4230203-10
4	4	4	4	4	PIN, Actuator retainer	4210246-10
1	1	1	1	1	PUSHBUTTON, Control: power	4100160-20
1	1	1	1	1	PLATE, Pushbutton: power	4110234-10
1	1	1	1	1	PUSHBUTTON, Control: speed	4100160-10
1	1	1	1	1	PLATE, Pushbutton: speed, 7½-15 ips	4040726-10
	1			1	PLATE, Pushbutton: speed, 15-30 ips	4040726-20
1	1	1	1	1	ESCUTCHEON, Power and speed control	Not available
2	2	2	2	2	SCREW, Machine: flat head, socket drive, 6-32 by 1/4 in. lg.	471-776
1	1	1	1	1	KNOB, Fast mode slider	4100173-10
1	1	1	1	1	SCREW, Set: headless, socket drive, 8-32 by 1/8 in. lg.	477-348
1	1	1	1	1	ESCUTCHEON ASSEMBLY, Pushbutton control	4040715-10
4	4	4	4	4	SPRING, Pushbutton control	4270209-10
1	1	1	1	1	SPRING, Pushbutton control (record)	4270209-20
1	1	1	1	1	PUSHBUTTON, Control: stop	4100160-10
1	1	1	1	1	PLATE, Pushbutton: stop	4110231-10
1	1	1	1	1	PUSHBUTTON, Control: fast	4100160-30
1	1	1	1	1	PLATE, Pushbutton: fast	4100231-30
1	1	1	1	1	PUSHBUTTON, Control: play	4100160-20
1	1	1	1	1	PLATE, Pushbutton: play	4110231-20
1	1	1	1	1	PUSHBUTTON, Control: edit	4100160-40
1	1	1	1	1	PLATE, Pushbutton: edit	4100231-40
1	1	1	1	1	PUSHBUTTON, Control: record	4100160-50
1	1	1	1	1	PLATE, Pushbutton: record	4110231-50
1	1	1	1	1	ESCUTCHEON, Pushbutton control	Not available
2	2	2	2	2	SCREW, Machine: flat head, socket drive, 6-32 by 1/4 in. lg.	471-776
1	1	1	1	1	FLANGE, Tape guide: upper	4220209-10
1	1	1	1	1	SPACER, Tape guide	4220215-10
1	1	1	1	1	FLANGE, Tape guide: lower	4220210-10
2	2	2	2	2	SCREW, Tape guide	4400610-10
1	1	1	1	1	BASE, Tape guide	4330222-10
2	2	2	2	2	SCREW, Machine: cap head, socket drive, 6-32 by 5/8 in. lg.	470-072
1	1			1	STROBOSTICKER, 60 cycle	4170128-10
				1	STROBOSTICKER, 50 cycle	4170128-20
1	1	1	1	1	CONTROL BOX AND SWITCH ASSEMBLY	4050331-10
S510	1	1	1	1	SWITCH ASSEMBLY, Fastwind	4040716-10

TAPE TRANSPORT - 1/4" TAPE (CONTINUED)

Ref. Sym.	4020244				DESCRIPTION	Ampex Part Number
	-01	-02	-03	-04		
	10	10	10	10	SWITCH, Fastwind	4620171-10
	3	3	3	3	SPACER, Mounting: fastwind switch	4220195-10
	2	2	2	2	ROD, Tie: fastwind switch	4210242-10
	4	4	4	4	NUT, Hex: 2-56	492-007
	4	4	4	4	WASHER, Lock: internal tooth, No.2	502-023
	1	1	1	1	SLIDE, Actuator: fastwind switch	4230200-10
	2	2	2	2	ROD, Tie: actuator, fastwind switch	4210243-10
	4	4	4	4	RING, Retainer: external, self-locking, Truarc 5105-9-S-PP	430-039
	2	2	2	2	SPRING, Fastwind switch	4270210-10
	1	1	1	1	BRACKET, Mounting	Not available
	2	2	2	2	SCREW, Machine: pan head, Phillips drive, 6-32 by 3/8 in. lg.	471-069
	2	2	2	2	NUT, Kep: 6-32	496-005
	1	1	1	1	BRACKET ASSEMBLY, Pushbutton control	4040714-10
S504	5	5	5	5	SWITCH, Lever: subminiature, SPDT, Cherry E-61-10A	120-394
S506	-	-	-	-	(Same as S504)	120-394
S507	-	-	-	-	(Same as S504)	120-394
S508	-	-	-	-	(Same as S504)	120-394
S509	-	-	-	-	(Same as S504)	120-394
	10	10	10	10	SCREW, Machine: pan head, Phillips drive, 2-56 by 1/2 in. lg.	472-456
	10	10	10	10	WASHER, Flat: No.2	501-007
	10	10	10	10	WASHER, Lock: split ring, No.2	502-001
	5	5	5	5	HOLDER, Pilot lamp	4630009-10
	5	5	5	5	SCREW, Machine: pan head, Phillips drive, 6-32 by 3/8 in. lg.	471-069
	5	5	5	5	WASHER, Lock: external tooth, No.6	502-014
	1	1	1	1	BRACKET, Mounting	Not available
	1	1	1	1	SWITCH ASSEMBLY, Power and speed control	4040724-10
	2	2	2	2	SPRING, Pushbutton	4270208-10
	3	3	3	3	HOLDER, Pilot lamp	150-045
	3	3	3	3	SCREW, Machine: pan head, Phillips drive, 6-32 by 1/4 in. lg.	471-067
	3	3	3	3	WASHER, Lock: external tooth, No.6	502-014
	1	1	1	1	INSULATOR, Switch	4170265-10
	2	2	2	2	SCREW, Self-tapping: hex washer head, slot drive, #6 by 1/4 in. lg.	476-998
S502	4	4	4	4	SWITCH, Lever: subminiature, SPDT, Cherry E-62-10H	120-398
	2	2	2	2	INSULATOR, Switch	4170263-10
	2	2	2	2	SCREW, Machine: pan head, Phillips drive, 2-56 by 1-3/8 in. lg.	472-898
	2	2	2	2	WASHER, Lock: internal tooth, No.2	502-023
	2	2	2	2	NUT, Hex: 2-56	492-007
S501	2	2	2	2	SWITCH, Lever: subminiature, SPDT, Cherry E-62-10H	120-398
	1	1	1	1	INSULATOR, Switch	4170263-10
	2	2	2	2	SCREW, Machine: pan head, Phillips drive, 2-56 by 7/8 in. lg.	472-459
	2	2	2	2	WASHER, Lock: internal tooth, No.2	502-023
	2	2	2	2	NUT, Hex: 2-56	492-007
	1	1	1	1	INSULATOR, Switch	4170264-10
	1	1	1	1	BRACKET, Mounting	Not available
P510	1	1	1	1	CONNECTOR, Plug: female, 4 contacts, Jones S-304-CCT-L	144-032
	2	2	2	2	CONNECTOR, Solderless: disconnect splice	171-008
	1	1	1	1	FANNING STRIP, Terminal: 8 position, Kulka 649-8	185-136
	1	1	1	1	CONTROL BOX ASSEMBLY	4050332-10
*	1	1	1	1	BIAS OSCILLATOR ASSEMBLY	4020237-01
	1	1	1	1	BRACKET ASSEMBLY, Oscillator	4050335-10
CR502	4	4	4	4	RECTIFIER, Silicon: 10 amp	580-035
CR503	-	-	-	-	(Same as CR502)	580-035
CR504	-	-	-	-	(Same as CR502)	580-035
CR505	-	-	-	-	(Same as CR502)	580-035
	2	2	2	2	BRACKET, Rectifier	4260238-10
	2	2	2	2	SCREW, Self-tapping: hex washer head, slot drive, #6 by 1/4 in. lg.	476-011
	1	1	1	1	FASTENER, Oscillator mounting	310-162
J501	1	1	1	1	CONNECTOR, Receptacle: female, 15 contacts, Cannon DA-15S	146-020
	2	2	2	2	SCREW, Self-tapping: hex washer head, slot drive, #4 by 3/16 in. lg.	476-185
	1	1	1	1	BRACKET, Oscillator	4260308-10
	1	1	1	1	ETCHED BOARD ASSEMBLY, Control box	4050333-10
C501	1	1	1	1	CAPACITOR, Electrolytic: 30 mfd, 250 vdcw, Sprague type DEE	031-468
C503	6	6	6	6	CAPACITOR, Mylar: 0.047 mfd, ±10%, 400 vdcw, El Menco 4 DP-3-473	035-764
C504	2	2	2	2	CAPACITOR, Mylar: 0.0047 mfd, ±10%, 600 vdcw, El Menco 6 DP-1-472	035-768
C505	-	-	-	-	(Same as C504)	035-768
C507	4	4	4	4	CAPACITOR, Mylar: 0.22 mfd, ±10%, 400 vdcw, El Menco 4 DP-5-224	035-766
C508	-	-	-	-	(Same as C503)	035-764

* See separate parts list later in this section.

TAPE TRANSPORT - 1/4" TAPE (CONTINUED)

Ref. Sym.	4020244				DESCRIPTION	Ampex Part Number
	-01	-02	-03	-04		
C510	2	2	2	2	CAPACITOR, Mylar: 0.1 mfd, ±10%, 400 vdcw, El Menco 4 DP-3-104	035-765
C511	1	1	1	1	CAPACITOR, Mylar: 0.5 mfd, ±10%, 400 vdcw, El Menco 4 DP-6-504	035-779
C514	-	-	-	-	(Same as C503)	035-764
C515	-	-	-	-	(Same as C510)	035-765
C516	-	-	-	-	(Same as C507)	035-766
C517	-	-	-	-	(Same as C503)	035-764
C518	-	-	-	-	(Same as C503)	035-764
C519	-	-	-	-	(Same as C507)	035-766
C520	-	-	-	-	(Same as C507)	035-766
C521	-	-	-	-	(Same as C503)	035-764
CR501	3	3	3	3	DIODE, Crystal: diffused silicon, Type 1N2864	013-339
CR506	11	11	11	11	DIODE, Crystal: diffused silicon, Type 1N2863	580-027
CR507	-	-	-	-	(Same as CR506)	580-027
CR508	-	-	-	-	(Same as CR506)	580-027
CR509	-	-	-	-	(Same as CR506)	580-027
CR510	-	-	-	-	(Same as CR506)	580-027
CR511	-	-	-	-	(Same as CR506)	580-027
CR512	-	-	-	-	(Same as CR506)	580-027
CR513	-	-	-	-	(Same as CR506)	580-027
CR514	-	-	-	-	(Same as CR506)	580-027
CR515	-	-	-	-	(Same as CR506)	580-027
CR516	-	-	-	-	(Same as CR506)	580-027
CR517	-	-	-	-	(Same as CR501)	013-339
CR518	-	-	-	-	(Same as CR501)	013-339
R502	1	1	1	1	RESISTOR, Fixed: wirewound, 150 ohms, ±5%, 10 W	047-660
R503	2	2	2	2	RESISTOR, Fixed: composition, 10 ohms, ±10%, 1/2 W	041-032
R504	1	1	1	1	RESISTOR, Fixed: composition, 150 ohms, ±10%, 1/2 W	041-241
R505	9	9	9	9	RESISTOR, Fixed: composition, 100 ohms, ±10%, 1/2 W	041-038
R506	1	1	1	1	RESISTOR, Fixed: composition, 820 ohms, ±10%, 1/2 W	041-047
R509	1	1	1	1	RESISTOR, Fixed: wirewound, 33 ohms, ±10%, 2 W	047-654
R510	-	-	-	-	(Same as R505)	041-038
R511	2	2	2	2	RESISTOR, Fixed: wirewound, 2 ohms, ±5%, 10 W	047-655
R512	-	-	-	-	(Same as R511)	047-655
R513	-	-	-	-	(Same as R505)	041-038
R519	2	2	2	2	RESISTOR, Fixed: wirewound, 15 ohms, ±5%, 10 W	047-658
R520	4	4	4	4	RESISTOR, Fixed: wirewound, 5 ohms, ±5%, 10 W	047-656
R521	2	2	2	2	RESISTOR, Fixed: wirewound, 40 ohms, ±5%, 10 W	047-659
R522	-	-	-	-	(Same as R520)	047-656
R523	-	-	-	-	(Same as R520)	047-656
R524	-	-	-	-	(Same as R521)	047-659
R525	-	-	-	-	(Same as R520)	047-656
R526	-	-	-	-	(Same as R519)	047-658
R527	-	-	-	-	(Same as R505)	041-038
R528	-	-	-	-	(Same as R505)	041-038
R529	-	-	-	-	(Same as R505)	041-038
R530	1	1	1	1	RESISTOR, Fixed: wirewound, 10 ohms, ±5%, 10 W	047-657
R531	-	-	-	-	(Same as R503)	041-032
R532	1	1	1	1	RESISTOR, Fixed: wirewound, 500 ohms, ±5%, 10 W	047-815
R533	1	1	1	1	RESISTOR, Fixed: composition, 22 ohms, ±10%, 1/2 W	041-033
R534	-	-	-	-	(Same as R505)	041-038
R535	-	-	-	-	(Same as R505)	041-038
R536	1	1	1	1	RESISTOR, Fixed: wirewound, 700 ohms, ±5%, 10 W	047-661
R537	-	-	-	-	(Same as R505)	041-038
RV501	4	4	4	4	VARISTOR, Silicon carbide, 24 vdc	046-092
RV502	-	-	-	-	(Same as RV501)	046-092
RV503	-	-	-	-	(Same as RV501)	046-092
RV504	-	-	-	-	(Same as RV501)	046-092
C502	1	1	1	1	CAPACITOR, Electrolytic: 2000-750 mfd, 50 vdcw	4550145-20
C509	1	1	1	1	CAPACITOR, Electrolytic: 500-300-200-100 mfd	4550145-40
C512	1	1	1	1	CAPACITOR, Electrolytic: 1000 mfd, 100 vdcw	4550145-30
C513	1	1	1	1	CAPACITOR, Electrolytic: 500 mfd, 200 vdcw	4550145-10
F501	2	2	2	2	FUSE, Cartridge: 5 amp, 125v, slow blow, Littelfuse 313005 (115v operation)	070-020
F502	-	-	-	-	(Same as F501) (115v operation)	070-020
F502	-	-	-	-	(Same as F501) (230v operation)	070-001
F503	1	1	1	1	FUSE, Cartridge: 3 amp, 125v, slow blow, Littelfuse 313003 (115v operation)	070-002
F503	1	1	1	1	FUSE, Cartridge: 2 amp, 250v, fast blow, Littelfuse 312002 (230v operation)	070-016
F504	-	-	-	-	(Same as F501)	070-001
F505	1	1	1	1	FUSE, Cartridge: 1 amp, 125v, slow blow, Littelfuse 313001	070-004

TAPE TRANSPORT - 1/4" TAPE (CONTINUED)

Ref. Sym.	4020244				DESCRIPTION	Ampex Part Number
	-01	-02	-03	-04		
J502	1	1	1	1	CONNECTOR, Receptacle: male, 3 contact, MS3102A10SL-3P	143-008
J503	1	1	1	1	CONNECTOR, Receptacle: female, 6 contact, Jones S-306-AB	146-004
J504	1	1	1	1	CONNECTOR, Receptacle: male, 3 contact, Hubbell 7556G	147-052
J505	1	1	1	1	CONNECTOR, Receptacle: female, 2 contact, Despard 1320 & 1354	146-014
J506	4	4	4	4	CONNECTOR, Receptacle: female, 8 contact, Jones S-308-AB	146-003
J507	1	1	1	1	CONNECTOR, Receptacle: female, 12 contact, Jones S-312-AB	146-009
J508	1	1	1	1	CONNECTOR, Receptacle: female, 4 contact, Jones S-304-AB	146-005
J509	1	1	1	1	CONNECTOR, Receptacle: female, 10 contact, Jones S-310-AB	146-018
J511	-	-	-	-	(Same as J506)	146-003
J512	-	-	-	-	(Same as J506)	146-003
J513	-	-	-	-	(Same as J506)	146-003
K501	2	2	2	2	RELAY, 4 circuit	4590101-20
K502	-	-	-	-	(Same as K501)	4590101-20
K503	3	3	3	3	RELAY, 6 circuit	4590101-30
K504	2	2	2	2	RELAY, 2 circuit	4590101-10
K505	-	-	-	-	(Same as K503)	4590101-30
K506	-	-	-	-	(Same as K503)	4590101-30
K507	-	-	-	-	(Same as K504)	4590101-10
L501	1	1	1	1	CHOKER, Filter	4580174-10
P506	1	1	1	1	DUMMY PLUG ASSEMBLY, Capstan motor amplifier	4050138-20
P507	1	1	1	1	DUMMY PLUG ASSEMBLY, Remote control	4050371-01
R501	1	1	1	1	RESISTOR, Variable: 50K ohms	4520145-40
R507	1	1	1	1	RESISTOR, Fixed: composition, 470 ohms, ±10%, 2 W	041-199
R508	1	1	1	1	RESISTOR, Variable: 5000 ohms	4520150-10
R514	1	1	1	1	RESISTOR, Fixed: composition, 6800 ohms, ±10%, 1 W	041-156
S503	1	1	1	1	SWITCH, Line voltage adjust	4620177-10
T501	1	1	1	1	TRANSFORMER, Power	4580179-10
	5	5	5	5	HOLDER, Fuse: Littelfuse 342012	085-001
	1	1	1	1	KNOB	4100105-02
	1	1	1	1	SHIELD, Transformer	4290550-01
DS501	8	8	8	8	LAMP, Incandescent: miniature, bayonet, 24v, 0.07 amp, G.E. type 1829	060-011
DS502	-	-	-	-	(Same as DS501)	060-011
DS503	-	-	-	-	(Same as DS501)	060-011
DS504	-	-	-	-	(Same as DS501)	060-011
DS505	-	-	-	-	(Same as DS501)	060-011
DS506	-	-	-	-	(Same as DS501)	060-011
DS507	-	-	-	-	(Same as DS501)	060-011
DS508	-	-	-	-	(Same as DS501)	060-011

TAPE TRANSPORT - 1/2" TAPE

Ref. Sym.	4020244				DESCRIPTION	Ampex Part Number
	-05	-06	-07	-08		
P503	X				TAPE TRANSPORT, 7-1/2 - 15 ips, 60 cps	4020244-05
		X			TAPE TRANSPORT, 15 - 30 ips, 60 cps	4020244-06
			X		TAPE TRANSPORT, 7-1/2 - 15 ips, 50 cps	4020244-07
				X	TAPE TRANSPORT, 15 - 30 ips, 50 cps	4020244-08
		1			DRIVE MOTOR AND BRACKET ASSEMBLY	4030206-10
			1		DRIVE MOTOR AND BRACKET ASSEMBLY	4030206-20
				1	DRIVE MOTOR AND BRACKET ASSEMBLY	4030206-30
					DRIVE MOTOR AND BRACKET ASSEMBLY	4030206-40
		1			MOTOR ASSEMBLY, Drive	4030197-10
			1		MOTOR ASSEMBLY, Drive	4030197-20
				1	MOTOR ASSEMBLY, Drive	4030197-30
					MOTOR ASSEMBLY, Drive	4030197-40
		1			PULLEY, Drive motor	Not available
		1	1		MOTOR, Drive	Not available
		1	1	1	CONNECTOR, Plug: male, 6 contact, Jones P-306-CCT	145-004
		1	1	1	PLATE, Drive motor mounting	4330247-01
		4	4	4	SCREW, Machine: flat head, Phillips drive, 10-24 by 1/2 in. lg.	471-734
		1	1	1	RING, Retaining: external, beveled, Truarc 5102-231-MD	430-366
		1	1	1	MOUNTING BRACKET ASSEMBLY, Drive motor	4030205-10
		1	1	1	BRACKET, Support: motor mounting	4260296-10
		1	1	1	BRACKET, Mounting: motor	4260299-10
		1	1	1	STOP, Drive motor	4220192-10
		1	1	1	WASHER, Lock: split ring, 1/4 in.	502-006
		1	1	1	SHAFT	4210175-10
		2	2	2	BEARING, Ball: Fafnir A38KDD	421-083
		2	2	2	RING, Retaining: internal, flat, Truarc N5000-86-S-ZD	430-028
		a/r	a/r	a/r	WASHER, Shim: 0.005 in. thk.	4440113-10
		a/r	a/r	a/r	WASHER, Shim: 0.015 in. thk.	4440113-30
		2	2	2	SCREW, Set: headless, socket drive, 8-32 by 1/4 in. lg.	477-041
		1	1	1	BEARING, Ball: Fafnir B546FS171	421-228
		4	4	4	SCREW, Machine: pan head, Phillips drive, 6-32 by 3/8 in. lg.	471-069
		4	4	4	NUT, Hex: 6-32	492-009
		4	4	4	WASHER, Lock: external tooth, No.6	502-014
		1	1	1	CAPACITOR ASSEMBLY, Motor	4050336-10
	C506	1	1	1	CAPACITOR, Motor	4540292-30
		1	1	1	BOOT, Safety: Sprague 301-66	032-082
		2	2	2	CONNECTOR, Solderless: slotted ring, Amp 328394	171-360
		2	2	2	SCREW, Machine: pan head, Phillips drive, 10-24 by 5/8 in. lg.	471-865
		2	2	2	WASHER, Flat: No.10	501-011
		2	2	2	WASHER, Lock: external tooth, No. 10	502-016
1		1	1	ACTUATOR ASSEMBLY, Drive motor	4030204-10	
		1	1	ACTUATOR ASSEMBLY, Drive motor	4030204-20	
		1	1	SOLENOID ASSEMBLY	4030202-20	
		1	1	SOLENOID	4590106-10	
K507	1	1	1	BOLT, Eye	4400496-90	
	1	1	1	PIN, Clevis: 1/8 in. dia. by 17/32 in. lg.	400-009	
	1	1	1	PIN, Cotter: 1/16 in. dia. by 1/2 in. lg.	401-005	
	1	1	1	WASHER, Felt: 1/2 in. OD by 1/4 in. ID by 1/4 in. thk.	503-015	
	1	1	1	STOP, Solenoid	4220139-20	
	2	2	2	SCREW, Machine: pan head, Phillips drive 8-32 by 1/4 in. lg.	471-076	
	2	2	2	WASHER, Lock: external tooth, No.8	502-068	
	2	2	2	CONNECTOR, Solderless: slotted ring, Amp 328394	171-360	
	1	1	1	PLATE, Solenoid adapter	4330195-10	
	4	4	4	SCREW, Machine: flat head, Phillips drive, 8-32 by 1/4 in. lg.	471-343	
1	1	1	STOP, Drive motor	4220196-10		
	1	1	STOP, Drive motor	4220224-10		
	1	1	ANCHOR, Motor return spring	4260295-10		
2	2	2	SCREW, Machine: pan head, Phillips drive, 8-32 by 1/2 in. lg.	471-080		
2	2	2	WASHER, Flat: No.8	501-911		
2	2	2	WASHER, Lock: external tooth, No.8	502-015		
1	1	1	PAD	4130150-10		
1	1	1	SCREW, Set: headless, socket drive, 10-32 by 3/4 in. lg.	477-340		
1	1	1	NUT, Hex: 10-32	492-011		
2	2	2	SCREW, Machine: pan head, Phillips drive, 10-24 by 5/8 in. lg.	471-865		
2	2	2	WASHER, Lock: external tooth, No.10	502-016		
1	1	1	ANGLE, Drive motor actuator	4260294-10		
	1	1	ANGLE, Drive motor actuator	4260311-10		
			1	ANGLE, Drive motor actuator	4260312-10	

TAPE TRANSPORT - 1/2" TAPE (CONTINUED)

Ref. Sym.	4020244				DESCRIPTION	Ampex Part Number
	-05	-06	-07	-08		
	1	1	1	1	SCREW, Set: headless, socket drive, 1/4 - 28 by 1-3/4 in. lg.	477-339
	1	1	1	1	NUT, Hex: 1/4-28	492-037
	4	4	4	4	SCREW, Machine: pan head, Phillips drive, 10-24 by 5/8 in. lg.	471-865
	4	4	4	4	WASHER, Lock: external tooth, No.10	502-016
	1	1	1	1	SHIELD, Motor	4290516-10
	1	1	1	1	PAD, Shield spacer	4130166-10
	1	1	1	1	CLAMP, Shield	300-096
	2	2	2	2	MOUNT, Isolation spring	4260390-01
	3	3	3	3	SPRING, Isolation and actuator return	4270222-10
	1	1	1	1	PIN, Clevis: 1/8 in. dia. by 17/32 in. lg.	400-009
	1	1	1	1	SPRING, Actuator solenoid return	4270162-10
	1	1	1	1	NUT, Hex: self locking, 10-32	493-008
	1	1	1	1	STOP, Solenoid	4220200-10
	2	2	2	2	SCREW, Machine: pan head, Phillips drive, 8-32 by 1/4 in. lg.	471-076
	2	2	2	2	WASHER, Lock: external tooth, No.8	502-015
	1	1	1	1	WASHER, Felt: 1/2 in. OD by 1/4 in. ID by 1/4 in. thk.	503-015
	1	1	1	1	PIN, Clevis: 1/8 in. dia. by 17/32 in. lg.	400-009
	1	1	1	1	PIN, Cotter: 1/16 in. dia. by 1/2 in. lg.	401-005
	2	2	2	2	WASHER, Flat: No.4	501-008
	1	1	1	1	BOLT, Eye	4400612-10
	1	1	1	1	DRAWBAR, Capstan solenoid	4210241-10
	2	2	2	2	PIN, Roll: stainless steel, 1/8 in. dia. by 5/8 in. lg.	406-030
K508	2	2	2	2	SOLENOID	4590063-10
	8	8	8	8	SCREW, Machine: pan head, Phillips drive, 8-32 by 1/2 in. lg.	471-080
	8	8	8	8	WASHER, Lock: external tooth, No.8	502-015
S505	1	1	1	1	SWITCH, Lever: subminiature, SPDT, Cherry E-61-10H	120-436
	1	1	1	1	INSULATOR, Switch	4170204-10
	2	2	2	2	SCREW, Machine: pan head, Phillips drive, 2-56 by 1/2 in. lg.	472-456
	2	2	2	2	WASHER, Flat: No.2	501-202
	2	2	2	2	WASHER, Lock: split ring, No.2	502-094
	1	1	1	1	STRIP, Terminal: barrier, 8 terminals, Kulka 410-8	180-453
	4	4	4	4	SCREW, Machine: pan head, Phillips drive, 2-56 by 1/2 in. lg.	472-456
	4	4	4	4	WASHER, Lock: split ring, No.2	502-094
	6	6	6	6	CONNECTOR, Solderless: slotted ring, Amp 328394	171-360
	1	1	1	1	REEL IDLER ASSEMBLY	4030200-20
	1	1	1	1	BRAKE ASSEMBLY	4030201-10
	1	1	1	1	HOUSING, Brake	4330112-10
	1	1	1	1	BAND, Brake	4040414-10
	1	1	1	1	SPRING, Leaf: brake band	4270164-10
	2	2	2	2	SPRING, Tension: short	4270163-10
	1	1	1	1	SPRING, Tension: long	4270211-10
	1	1	1	1	BOLT, Eye	4400496-60
	2	2	2	2	NUT, Hex: 10-32	492-011
	1	1	1	1	CROSSHEAD, Brake	4330109-10
	2	2	2	2	SCREW, Machine: flat head, Phillips drive, 6-32 by 1-1/8 in. lg.	471-719
	4	4	4	4	WASHER, Finishing: No. 6	506-001
	2	2	2	2	WASHER, Flat: No.6	501-009
	2	2	2	2	SPACER	4220141-10
	2	2	2	2	NUT, Hex: self locking, 6-32	493-006
	1	1	1	1	ANCHOR	4330110-10
	2	2	2	2	SCREW, Sem: pan head, Phillips drive, 6-32 by 5/16 in. lg.	475-085
	1	1	1	1	PIN, Roll: 1/8 in. dia. by 3/4 in. lg.	406-005
	2	2	2	2	LINK, Brake band	4230161-10
	4	4	4	4	SCREW, Machine: cap, socket drive, 4-40 by 3/16 in. lg.	470-007
	4	4	4	4	WASHER, Lock: split ring, No.4	502-002
	2	2	2	2	CLAMP, Band link	4330113-10
	1	1	1	1	LEVER, Brake	4230162-10
	2	2	2	2	PIN, Drivelock: 1/8 in. dia. by 1/2 in. lg.	403-008
	1	1	1	1	PIN, Clevis: 1/8 in. dia. by 9/32 in. lg.	400-002
	1	1	1	1	PIN, Cotter: 1/16 in. dia. by 1/2 in. lg.	401-005
	1	1	1	1	STOP, Solenoid	4260184-10
	2	2	2	2	SCREW, Sem: pan head, Phillips drive, 8-32 by 1/4 in. lg.	475-072
	2	2	2	2	LINK, Solenoid	4230163-10
	1	1	1	1	PIN, Clevis: 1/8 in. dia. by 15/32 in. lg.	400-007
	1	1	1	1	PIN, Cotter: 1/16 in. dia. by 1/2 in. lg.	401-005
	1	1	1	1	BRACKET, Solenoid	4260310-10
	2	2	2	2	SCREW, Sem: pan head, Phillips drive, 8-32 by 3/8 in. lg.	475-044
K510	1	1	1	1	SOLENOID	4590102-10

TAPE TRANSPORT - 1/2" TAPE (CONTINUED)

Ref. Sym.	4020244				DESCRIPTION	Ampex Part Number	
	-05	-06	-07	-08			
C522	2	2	2	2	SCREW, Sem: pan head, Phillips drive, 8-32 by 1/4 in. lg.	475-072	
	2	2	2	2	CONNECTOR, Solderless: disconnect splice	171-008	
	3	3	3	3	SCREW, Machine: pan head, Phillips drive, 6-32 by 1/2 in. lg.	471-071	
	3	3	3	3	WASHER, Lock: external tooth, No.6	502-014	
	1	1	1	1	MOTOR ASSEMBLY, Torque	4040731-20	
	1	1	1	1	PULLEY, Reel idler	4250159-20	
	1	1	1	1	SCREW, Set: headless, socket drive, 8-32 by 3/8 in. lg.	477-043	
	1	1	1	1	ADAPTER, Motor mounting	4220197-10	
	4	4	4	4	SCREW, Machine: pan head, Phillips drive, 6-32 by 1/2 in. lg.	475-034	
	4	4	4	4	WASHER, Lock: external tooth, No.8	502-014	
	1	1	1	1	DRUM, Brake	Not available	
	1	1	1	1	PIN, Roll: 3/32 in. dia. by 3/4 in. lg.	406-006	
	1	1	1	1	MOTOR, Torque	Not available	
	1	1	1	1	CAPACITOR ASSEMBLY, Motor	4050336-20	
	1	1	1	1	CAPACITOR, Motor	4540292-30	
	1	1	1	1	BOOT, Safety: Sprague 301-66	032-082	
	2	2	2	2	CONNECTOR, Solderless: disconnect splice	171-008	
	2	2	2	2	WASHER, Flat: No.8	501-010	
	P511	1	1	1	1	CONNECTOR, Plug: male, 8 contact, Jones P308-CCT-L	145-013
		4	4	4	4	CONNECTOR, Solderless: knife disconnect	171-008
1		1	1	1	TAKEUP ASSEMBLY	4030226-20	
1		1	1	1	BRAKE ASSEMBLY	4030114-40	
1		1	1	1	HOUSING, Brake	4330112-10	
1		1	1	1	BAND, Brake	4040414-10	
1		1	1	1	SPRING, Leaf: brake band	4270164-10	
2		2	2	2	SPRING, Tension: short	4270163-10	
1		1	1	1	SPRING, Tension: long	4270178-10	
1		1	1	1	BOLT, Eye	4400496-60	
2		2	2	2	NUT, Hex: 10-32	492-011	
1		1	1	1	CROSSHEAD, Brake	4330109-10	
2		2	2	2	SCREW, Machine: flat head, Phillips drive, 6-32 by 1-3/8 in. lg.	472-890	
4		4	4	4	WASHER, Finishing: No.6	506-001	
2		2	2	2	SPACER	4220141-10	
2		2	2	2	NUT, Hex: self locking, 6-32	493-006	
1		1	1	1	ANCHOR	4330110-10	
2		2	2	2	SCREW, Sem: pan head, Phillips drive, 6-32 by 5/16 in. lg.	475-085	
1		1	1	1	PIN, Roll: 1/8 in. dia. by 7/8 in. lg.	406-042	
2		2	2	2	LINK, Brake band	4230161-10	
4	4	4	4	SCREW, Machine: cap, socket drive, 4-40 by 3/16 in lg.	470-007		
4	4	4	4	WASHER, Lock: split ring, No.4	502-002		
2	2	2	2	CLAMP, Band link	4330113-10		
1	1	1	1	LEVER, Brake	4230162-10		
2	2	2	2	PIN, Drivelock: 1/8 in. dia. by 1/2 in. lg.	403-008		
1	1	1	1	PIN, Clevis: 1/8 in. dia. by 9/32 in. lg.	400-002		
1	1	1	1	PIN, Cotter: 1/16 in. dia. by 1/2 in. lg.	401-005		
1	1	1	1	STOP, Solenoid	4260184-10		
2	2	2	2	SCREW, Sem: pan head, Phillips drive, 8-32 by 1/4 in. lg.	475-072		
2	2	2	2	LINK, Solenoid	4230163-10		
1	1	1	1	PIN, Clevis: 1/8 in. dia. by 15/32 in. lg.	400-007		
1	1	1	1	PIN, Cotter: 1/16 in. dia. by 1/2 in. lg.	401-005		
1	1	1	1	BRACKET, Solenoid	4260183-10		
2	2	2	2	SCREW, Sem: pan head, Phillips drive, 8-32 by 3/8 in. lg.	475-044		
1	1	1	1	SOLENOID	4590067-10		
2	2	2	2	SCREW, Sem: pan head, Phillips drive, 8-32 by 1/4 in. lg.	475-072		
2	2	2	2	CONNECTOR, Solderless: disconnect splice	171-008		
3	3	3	3	SCREW, Machine: pan head, Phillips drive, 6-32 by 1/2 in. lg.	471-071		
3	3	3	3	WASHER, Lock: external tooth, No.6	502-014		
1	1	1	1	CAPACITOR ASSEMBLY, Motor	4050361-10		
C524	1	1	1	1	CAPACITOR, Motor	4540312-10	
	1	1	1	1	BOOT, Safety: Sprague	032-082	
2	2	2	2	CONNECTOR, Solderless: disconnect splice	171-008		
1	1	1	1	DRIVE PLATE, Reel: with EIA drive pins	4320128-10		
3	3	3	3	SCREW, Machine: button head, 4-40 by 3/16 in. lg.	470-382		
1	1	1	1	PAD, Turntable	4130152-10		
1	1	1	1	TURNTABLE	4250160-10		
1	1	1	1	SHIM, Turntable	4280125-10		
3	3	3	3	SCREW, Machine: button head, 8-32 by 1/2 in. lg.	470-384		
1	1	1	1	SHIELD, Motor	4290516-30		

TAPE TRANSPORT - 1/2" TAPE (CONTINUED)

Ref. Sym.	4020244				DESCRIPTION	Ampex Part Number
	-05	-06	-07	-08		
P513	1	1	1	1	CLAMP, Shield	300-096
	1	1	1	1	MOTOR ASSEMBLY, Torque	4040797-20
	1	1	1	1	HUB, Turntable	Not available
	1	1	1	1	PIN, Roll: 3/32 in. dia. by 3/4 in. lg.	406-006
	1	1	1	1	ADAPTER, Motor mounting	4220197-10
	4	4	4	4	SCREW, Machine: pan head, Phillips drive, 6-32 by 1/2 in. lg.	471-071
	4	4	4	4	WASHER, Lock: external tooth, No.6	502-014
	1	1	1	1	DRUM, Brake	Not available
	1	1	1	1	PIN, Roll: 3/32 in. dia. by 3/4 in. lg.	406-006
	1	1	1	1	MOTOR, Torque	Not available
	1	1	1	1	CONNECTOR, Plug: male, 8 contact, Jones P-308-CCT-L	145-013
	4	4	4	4	CONNECTOR, Solderless: disconnect splice	171-008
	1	1	1	1	REWIND ASSEMBLY	4030227-20
	1	1	1	1	BRAKE ASSEMBLY	4030114-30
	1	1	1	1	HOUSING, Brake	4330112-10
	1	1	1	1	BAND, Brake	4040414-10
	1	1	1	1	SPRING, Leaf: brake band	4270164-10
	2	2	2	2	SPRING, Tension: short	4270163-10
	1	1	1	1	SPRING, Tension: long	4270178-10
	1	1	1	1	BOLT, Eye	4400496-60
	2	2	2	2	NUT, Hex: 10-32	492-011
	1	1	1	1	CROSSHEAD, Brake	4330109-10
	2	2	2	2	SCREW, Machine: flat head, Phillips drive, 6-32 by 1-3/8 in. lg.	472-890
	4	4	4	4	WASHER, Finishing: No.6	506-001
	2	2	2	2	SPACER	4220141-10
	2	2	2	2	NUT, Hex: self locking, 6-32	493-006
	1	1	1	1	ANCHOR	4330110-10
	2	2	2	2	SCREW, Sem: pan head, Phillips drive, 6-32 by 5/16 in. lg.	475-085
	1	1	1	1	PIN, Roll: 1/8 in. dia. by 7/8 in. lg.	406-042
	2	2	2	2	LINK, Brake band	4230161-10
	4	4	4	4	SCREW, Machine: cap, socket drive, 4-40 by 3/16 in. lg.	470-007
	4	4	4	4	WASHER, Lock: split ring, No.4	502-002
	2	2	2	2	CLAMP, Band link	4330113-10
	1	1	1	1	LEVER, Brake	4230162-10
	2	2	2	2	PIN, Drivelock: 1/8 in. dia. by 1/2 in. lg.	403-008
	1	1	1	1	PIN, Clevis: 1/8 in. dia. by 9/32 in. lg.	400-002
	1	1	1	1	PIN, Cotter: 1/16 in. dia. by 1/2 in. lg.	401-005
	1	1	1	1	STOP, Solenoid	4260184-10
	2	2	2	2	SCREW, Sem: pan head, Phillips drive, 8-32 by 1/4 in. lg.	475-072
	2	2	2	2	LINK, Solenoid	4230163-10
1	1	1	1	PIN, Clevis: 1/8 in. dia. by 15/32 in. lg.	400-007	
1	1	1	1	PIN, Cotter: 1/16 in. dia. by 1/2 in. lg.	401-005	
1	1	1	1	BRACKET, Solenoid	4260183-10	
2	2	2	2	SCREW, Sem: pan head, Phillips drive, 8-32 by 3/8 in. lg.	475-044	
1	1	1	1	SOLENOID	4590067-10	
2	2	2	2	SCREW, Sem: pan head, Phillips drive, 8-32 by 1/4 in. lg.	475-072	
2	2	2	2	CONNECTOR, Solderless: disconnect splice	171-008	
3	3	3	3	SCREW, Machine: pan head, Phillips drive, 6-32 by 1/2 in. lg.	471-071	
3	3	3	3	WASHER, Lock: external tooth, No.6	502-014	
1	1	1	1	CAPACITOR ASSEMBLY, Motor	4050361-10	
C523	1	1	1	CAPACITOR, Motor	4540312-10	
1	1	1	1	BOOT, Safety: Sprague	032-082	
2	2	2	2	CONNECTOR, Solderless: disconnect splice	171-008	
1	1	1	1	DRIVE PLATE, Reel: with EIA drive pins	4320128-10	
3	3	3	3	SCREW, Machine: button head, 4-40 by 3/16 in. lg.	470-382	
1	1	1	1	PAD, Turntable	4130152-10	
1	1	1	1	TURNTABLE	4250160-10	
1	1	1	1	SHIM, Turntable	4280125-10	
3	3	3	3	SCREW, Machine: button head, 8-32 by 1/2 in. lg.	470-384	
1	1	1	1	SHIELD, Motor	4290516-30	
1	1	1	1	CLAMP, Shield	300-096	
1	1	1	1	MOTOR ASSEMBLY, Torque	4040797-20	
1	1	1	1	HUB, Turntable	Not available	
1	1	1	1	PIN, Roll: 3/32 in. dia. by 3/4 in. lg.	406-006	
1	1	1	1	ADAPTER, Motor mounting	4220197-10	
4	4	4	4	SCREW, Machine: pan head, Phillips drive 6-32 by 1/2 in. lg.	471-071	
4	4	4	4	WASHER, Lock: external tooth, No.6	502-014	
1	1	1	1	DRUM, Brake	Not available	

TAPE TRANSPORT - 1/2" TAPE (CONTINUED)

Ref. Sym.	4020244				DESCRIPTION	Ampex Part Number
	-05	-06	-07	-08		
P512	1	1	1	1	PIN, Roll: 3/32 in. dia. by 3/4 in. lg.	406-006
	1	1	1	1	MOTOR, Torque	Not available
	1	1	1	1	CONNECTOR, Plug: male, 8 contact, Jones P-308-CCT-L	145-013
	4	4	4	4	CONNECTOR, Solderless: disconnect splice	171-008
	1	1	1	1	FLYWHEEL ASSEMBLY, Damped	4030196-10
	1	1	1	1	CAP, Capstan	4100167-10
	1	1	1	1	SCREW, Set: headless, socket drive, 8-32 by 1/8 in. lg.	477-348
	1	1	1	1	CAPSTAN ASSEMBLY	4030199-10
	1	1	1	1	FLYWHEEL	Not available
	1	1	1	1	PIN, Roll: 5/32 in. dia. by 1-1/4 in. lg.	406-007
	a/r	a/r	a/r	a/r	WASHER, Shim: 0.625 in. OD by 0.500 in. ID by 0.003 in. thk.	501-050
	1	1	1	1	SEAL, Dust	4440247-10
	1	1	1	1	RING, Retaining: internal, bowed, Truarc 5001-125-S	430-064
	1	1	1	1	BEARING, Ball	Not available
	1	1	1	1	SHAFT, Capstan	Not available
	1	1	1	1	HOUSING ASSEMBLY, Capstan	Not available
	1	1	1	1	IDLER ASSEMBLY, Capstan	4030203-20
	1	1	1	1	CAP, Capstan idler	4100166-10
	1	1	1	1	RING, Lock	4320112-10
	1	1	1	1	RING, Retaining: external, flat, Truarc 5100-25-S	430-004
	a/r	a/r	a/r	a/r	WASHER, Shim: 0.437 in. OD by 0.250 in. ID by 0.002 in. thk.	501-049
	1	1	1	1	WASHER, Felt	4440239-10
	1	1	1	1	SHAFT, Capstan idler	Not available
	1	1	1	1	WASHER, Thrust	4440027-10
	1	1	1	1	WHEEL ASSEMBLY, Capstan idler	4040404-10
	1	1	1	1	SCREW, Set: headless, socket drive, 8-32 by 1/8 in. lg.	477-348
	1	1	1	1	POST ASSEMBLY, Tape turnaround	4040741-10
	1	1	1	1	SCREW, Set: headless, socket drive, 8-32 by 1/8 in. lg.	477-348
	1	1	1	1	NUT, Hex: self lock, 10-32	493-008
	1	1	1	1	SPRING, Solenoid pressure: capstan idler	4270162-10
	1	1	1	1	SPRING, Solenoid return: capstan idler	4270229-10
	1	1	1	1	ARM, Solenoid: capstan idler	4230212-10
	1	1	1	1	PIN, Roll: 1/8 in. dia. by 3/4 in. lg.	406-005
	1	1	1	1	ARM, Capstan idler	4230204-10
	1	1	1	1	BEARING, Capstan idler	Not available
	3	3	3	3	SCREW, Machine: cap, socket drive, 8-32 by 1/2 in. lg.	470-029
	1	1	1	1	DAMPER ASSEMBLY, Capstan idler	4040851-10
	1	1	1	1	SPRING, Dashpot arm	4270238-10
	1	1	1	1	PIN, Clevis: 1/8 in. dia. by 9/32 in. lg.	400-002
	1	1	1	1	HOLDDOWN, Dashpot arm	4600142-10
	1	1	1	1	SCREW, Machine: pan head, Phillips drive, 6-32 by 3/16 in. lg.	471-066
	1	1	1	1	WASHER, Lock: external tooth, No.6	502-014
	1	1	1	1	DASHPOT	4130157-20
	1	1	1	1	STOP, Dashpot arm	4220223-10
	1	1	1	1	SCREW, Machine: pan head, Phillips drive, 6-32 by 3/16 in. lg.	471-066
	1	1	1	1	WASHER, Lock: external tooth, No.6	502-014
	1	1	1	1	ARM ASSEMBLY, Dashpot	4030234-10
	1	1	1	1	SCREW, Shoulder	474-315
	1	1	1	1	PLATE ASSEMBLY, Damper mounting	4040852-10
	4	4	4	4	SCREW, Machine: pan head, Phillips drive, 6-32 by 3/8 in. lg.	471-069
4	4	4	4	WASHER, Flat: No.6	501-009	
4	4	4	4	WASHER, Lock: external tooth, No.6	502-014	
1	1	1	1	ARM ASSEMBLY, Takeup tension	4030216-20	
1	1	1	1	TOP, Takeup tension arm	4250180-10	
1	1	1	1	SCREW, Machine: flat head, socket drive, 4-40 by 3/8 in. lg.	471-490	
1	1	1	1	ARM SUBASSEMBLY, Takeup tension	4040774-10	
1	1	1	1	SCREW, Set: headless, socket drive, 6-32 by 3/8 in. lg.	477-347	
1	1	1	1	GUIDE, Tape	4210183-10	
1	1	1	1	END, Takeup tension arm	4330196-10	
1	1	1	1	SCREW, Machine: pan head, Phillips drive, 4-40 by 5/8 in. lg.	471-065	
1	1	1	1	WASHER, Lock: external tooth, No.4	502-013	
1	1	1	1	SPRING, Takeup tension arm	4270228-10	
1	1	1	1	COVER, Slot: takeup tension arm	4290523-10	
1	1	1	1	PIN, Roll: 3/32 in. dia. by 5/8 in. lg.	406-002	
1	1	1	1	SCREW, Nylon: fillister head, Phillips drive, 4-40 by 3/4 in. lg.	471-836	
1	1	1	1	RING, Retaining: grip, Truarc 555-31-S	430-117	
1	1	1	1	RING, Retaining: external, flat, Truarc 5100-31-S-ZD	430-007	
1	1	1	1	WASHER, Shim: 15/32 in. OD by 21/64 in. ID by 0.005 in. thk.	501-053	

TAPE TRANSPORT - 1/2" TAPE (CONTINUED)

Ref. Sym.	4020244				DESCRIPTION	Amper Part Number
	-05	-06	-07	-08		
	1	1	1	1	SHAFT, Takeup tension	4210273-10
	1	1	1	1	SCREW, Set: headless, socket drive, 10-32 by 1/4 in. lg.	477-118
	1	1	1	1	SPRING, Stop	4270227-10
	1	1	1	1	PIN, Roll: 3/32 in. dia. by 1 in. lg.	406-012
	1	1	1	1	HOUSING ASSEMBLY, Takeup arm	4030215-10
	2	2	2	2	BEARING, Bronze	423-019
	1	1	1	1	HOUSING	4290522-10
	2	2	2	2	SCREW, Machine: flat head, Phillips drive, 4-40 by 3/8 in. lg.	471-328
	1	1	1	1	ARM ASSEMBLY, Tape lifter	4040713-10
	2	2	2	2	PAD	4130150-10
	1	1	1	1	BEARING, Bronze	423-083
	1	1	1	1	ARM	4230199-10
	1	1	1	1	SCREW, Shoulder	474-313
	1	1	1	1	SPRING, Solenoid pressure: tape lifter	4270231-10
	1	1	1	1	SPRING, Solenoid return: tape lifter	4270176-10
	1	1	1	1	NUT, Hex: self locking, 10-32	493-008
	1	1	1	1	SOLENOID ASSEMBLY	4030202-10
K509	1	1	1	1	SOLENOID	4590106-10
	1	1	1	1	BOLT, Eye	4400604-10
	1	1	1	1	PIN, Clevis: 1/8 in. dia. by 17/32 in. dia.	400-009
	1	1	1	1	PIN, Cotter: 1/16 in. dia. by 1/2 in. lg.	401-005
	1	1	1	1	WASHER, Felt: 1/2 in. OD by 1/4 in. ID by 1/4 in. thk.	503-015
	1	1	1	1	STOP, Solenoid	4220139-20
	2	2	2	2	SCREW, Machine: pan head, Phillips drive, 8-32 by 1/4 in. lg.	471-076
	2	2	2	2	WASHER, Lock: external tooth, No.8	502-068
	2	2	2	2	CONNECTOR, Solderless: disconnect splice	171-008
	2	2	2	2	SCREW, Machine: pan head, Phillips drive, 10-24 by 3/8 in. lg.	472-415
	2	2	2	2	WASHER, Flat: No.10	501-011
	2	2	2	2	WASHER, Lock: external tooth, No.10	502-016
	1	1	1	1	ESCUTCHEON, Reel: right	4110245-10
	1	1	1	1	ESCUTCHEON, Reel: left	4110245-20
	8	8	8	8	SCREW, Reel excutcheon	4400611-10
	1	1	1	1	RESISTOR BOX ASSEMBLY, Tension control	Not available
	1	1	1	1	COVER, Resistor box	4290506-10
	4	4	4	4	SCREW, Self-tapping: pan head, Phillips drive, #6 by 1/4 in. lg.	476-011
R515	1	1	1	1	RESISTOR, Fixed: wirewound, tapped, 14 ohms	4510420-10
R516	1	1	1	1	RESISTOR, Fixed: wirewound, tapped, 22.5 ohms	4510421-10
R517	1	1	1	1	RESISTOR, Fixed: wirewound, tapped, 49 ohms	4510422-10
	3	3	3	3	STUD, Resistor mounting	4210283-10
	9	9	9	9	NUT, Kep: 8-32	496-001
	6	6	6	6	WASHER, Insulating	503-007
	6	6	6	6	WASHER, Centering	506-003
R518	1	1	1	1	RESISTOR, Fixed: composition, 330 ohms, ±10%, 1/2 W, RC20GF331K	041-042
	1	1	1	1	TIEPOINT, Solder lug: 3 terminals, Permonite 8020-3	180-240
J510	1	1	1	1	CONNECTOR, Receptacle: male, 4 contact, Jones P-304-AB	147-036
	2	2	2	2	SCREW, Sem: pan head, slot drive, 6-32 by 5/16 in. lg.	475-066
	2	2	2	2	NUT, Kep: 6-32	496-005
J514	1	1	1	1	CONNECTOR, Plug: female, 14 contact, Electric Regulator 300.105-21	144-297
	13	13	13	13	CONNECTOR, Solderless: Electric Regulator 71.25-2-2	169-572
	1	1	1	1	GROMMET, Elastic: MS-35489-8	260-020
	1	1	1	1	BRACKET, Resistor box	4260327-10
	4	4	4	4	SCREW, Machine: pan head, Phillips drive, 10-24 by 3/8 in. lg.	472-415
	4	4	4	4	WASHER, Lock: external tooth, No.10	502-016
	1	1	1	1	TENSION CONTROL ASSEMBLY	4040817-10
	1	1	1	1	POST, Sensing	4210278-10
	1	1	1	1	PLUG, Sensing post	4100155-10
	1	1	1	1	SCREW, Machine: pan head, Phillips drive, 6-32 by 5/16 in. lg.	471-068
	1	1	1	1	ARM, Tension control	4230227-10
	1	1	1	1	SCREW, Machine: pan head, Phillips drive, 6-32 by 5/16 in. lg.	471-068
	2	2	2	2	STOP, Tension arm	4220221-10
	2	2	2	2	SCREW, Machine: pan head, Phillips drive, 4-40 by 3/16 in. lg.	471-063
P514	1	1	1	1	SWITCH, Tension control	4620178-10
	1	1	1	1	YOKE, Actuator	4230210-10
	1	1	1	1	SLIDE, Actuator	4210280-10
	4	4	4	4	SCREW, Machine: pan head, Phillips drive, 6-32 by 5/16 in. lg.	471-068
	1	1	1	1	SPRING, Return	4270234-10
	1	1	1	1	DASHPOT, Tension control	4130157-10
	1	1	1	1	BRACKET, Dashpot mounting	4260363-10

TAPE TRANSPORT - 1/2" TAPE (CONTINUED)

Ref. Sym.	4020244				DESCRIPTION	Ampex Part Number
	-05	-06	-07	-08		
	2	2	2	2	SCREW, Machine: pan head, Phillips drive, 6-32 by 5/16 in. lg.	471-662
	1	1	1	1	TIMING BLOCK ASSEMBLY	4040821-10
	1	1	1	1	SPRING, Timing adjustment	4270235-10
	1	1	1	1	COUNTER BALANCE	4220220-10
	1	1	1	1	NUT, Hex: 4-40	492-008
	1	1	1	1	SCREW, Machine: cap head, socket drive, 4-40 by 5/8 in. lg.	470-013
	1	1	1	1	WASHER, Flat: No.4	501-008
	1	1	1	1	BRACKET, Dashpot actuating	4260362-10
	1	1	1	1	SCREW, Machine: pan head, Phillips drive, 4-40 by 3/8 in. lg.	471-062
	1	1	1	1	BLOCK, Adjusting	4220218-10
	1	1	1	1	SCREW, Set: headless, socket drive, 4-40 by 1/4 in. lg.	477-031
	1	1	1	1	SCREW, Machine: flat head, Phillips drive, 4-40 by 1/4 in. lg.	471-326
	1	1	1	1	RING, Retaining: grip, Truarc 555-31-S	430-117
	1	1	1	1	HUB, Tension arm	Not available
	2	2	2	2	SCREW, Set: headless, socket drive, 4-40 by 1/4 in. lg.	477-031
	1	1	1	1	WASHER, Shim: 0.010 in. thk.	4440113-20
	1	1	1	1	SHAFT, Tension control	Not available
	2	2	2	2	BEARING, Ball: Fafnir RM38KOD, FS30171	421-110
	2	2	2	2	RING, Retaining: internal, flat, Truarc N5000-86-S	430-027
	1	1	1	1	HOUSING, Tension control	Not available
	3	3	3	3	SCREW, Machine: pan head, Phillips drive, 10-24 by 3/4 in. lg.	472-418
	3	3	3	3	WASHER, Lock: external tooth, No.10	502-016
	1		1		ESCUTCHEON ASSEMBLY, Power and speed control	4040719-10
		1		1	ESCUTCHEON ASSEMBLY, Power and speed control	4040719-20
	2	2	2	2	PIN, Roll: 1/16 in. dia. by 3/8 in. lg.	406-022
	2	2	2	2	BALL, 5/32 in. dia.	420-998
	2	2	2	2	SPRING, Actuator	4270236-10
	2	2	2	2	ACTUATOR, Switch	4230202-10
	1	1	1	1	PIN, Power and speed switch actuator	4210247-10
	2	2	2	2	RING, Retaining: external, "E", Truarc 5144-9-MO	430-343
	2	2	2	2	ACTUATOR, Power and speed switch	4230203-10
	4	4	4	4	PIN, Actuator retainer	4210246-10
	1	1	1	1	PUSHBUTTON, Control: power	} must be ordered as a set
	1	1	1	1	PLATE, Pushbutton: power	
	1	1	1	1	PUSHBUTTON, Control: speed	} must be ordered as a set
	1		1		PLATE, Pushbutton: speed, 7 1/2-15 ips	
	1	1			PLATE, Pushbutton: speed, 15-30 ips	
	1	1	1	1	ESCUTCHEON, Power and speed control	Not available
	2	2	2	2	SCREW, Machine: flat head, socket drive, 6-32 by 1/4 in. lg.	471-776
	1	1	1	1	KNOB, Fast mode slider	4100173-10
	1	1	1	1	SCREW, Set: headless, socket drive, 8-32 by 1/8 in. lg.	477-348
	1	1	1	1	ESCUTCHEON ASSEMBLY, Pushbutton control	4040715-10
	4	4	4	4	SPRING, Pushbutton control	4270209-10
	1	1	1	1	SPRING, Pushbutton control (record)	4270209-20
	1	1	1	1	PUSHBUTTON, Control: stop	} must be ordered as a set
	1	1	1	1	PLATE, Pushbutton: stop	
	1	1	1	1	PUSHBUTTON, Control: fast	} must be ordered as a set
	1	1	1	1	PLATE, Pushbutton: fast	
	1	1	1	1	PUSHBUTTON, Control: play	} must be ordered as a set
	1	1	1	1	PLATE, Pushbutton: play	
	1	1	1	1	PUSHBUTTON, Control: edit	} must be ordered as a set
	1	1	1	1	PLATE, Pushbutton: edit	
	1	1	1	1	PUSHBUTTON, Control: record	} must be ordered as a set
	1	1	1	1	PLATE, Pushbutton: record	
	1	1	1	1	ESCUTCHEON, Pushbutton control	Not available
	2	2	2	2	SCREW, Machine: flat head, socket drive, 6-32 by 1/4 in. lg.	471-776
	1	1	1	1	FLANGE, Tape guide: upper	4220209-10
	1	1	1	1	SPACER, Tape guide	4220215-20
	1	1	1	1	FLANGE, Tape guide: lower	4220210-10
	2	2	2	2	SCREW, Tape guide	4400610-10
	1	1	1	1	BASE, Tape guide	4330222-10
	2	2	2	2	SCREW, Machine: cap head, socket drive, 6-32 by 5/8 in. lg.	470-072
	1	1			STROBOSTICKER, 60 cycle	4170128-10
			1	1	STROBOSTICKER, 50 cycle	4170128-20
	1	1	1	1	CONTROL BOX AND SWITCH ASSEMBLY	4050331-10
S510	1	1	1	1	SWITCH ASSEMBLY, Fastwind	4040716-10
10	10	10	10	10	SWITCH, Fastwind	4620171-10
3	3	3	3	3	SPACER, Mounting: fastwind switch	4220195-10

TAPE TRANSPORT - 1/2" TAPE (CONTINUED)

Ref. Sym.	4020244				DESCRIPTION	Ampex Part Number
	-05	-06	-07	-08		
	2	2	2	2	ROD, Tie: fastwind switch	4210242-10
	4	4	4	4	NUT, Hex: 2-56	492-007
	4	4	4	4	WASHER, Lock: internal tooth, No.2	502-023
	1	1	1	1	SLIDE, Actuator: fastwind switch	4230200-10
	2	2	2	2	ROD, Tie: actuator, fastwind switch	4210243-10
	4	4	4	4	RING, Retainer: external, self-locking, Truarc 5105-9-S-PP	430-039
	2	2	2	2	SPRING, Fastwind switch	4270210-10
	1	1	1	1	BRACKET, Mounting	Not available
	2	2	2	2	SCREW, Machine: pan head, Phillips drive, 6-32 by 3/8 in. lg.	471-069
	2	2	2	2	NUT, Kep: 6-32	496-005
	1	1	1	1	BRACKET ASSEMBLY, Pushbutton control	4040714-10
S504	5	5	5	5	SWITCH, Lever: subminiature, SPDT, Cherry E-61-10A	120-394
S506	-	-	-	-	(Same as S504)	120-394
S507	-	-	-	-	(Same as S504)	120-394
S508	-	-	-	-	(Same as S504)	120-394
S509	-	-	-	-	(Same as S504)	120-394
	10	10	10	10	SCREW, Machine: pan head, Phillips drive, 2-56 by 1/2 in. lg.	472-456
	10	10	10	10	WASHER, Flat: No.2	501-007
	10	10	10	10	WASHER, Lock: split ring, No.2	502-001
	5	5	5	5	HOLDER, Pilot lamp	4630009-10
	5	5	5	5	SCREW, Machine: pan head, Phillips drive, 6-32 by 3/8 in. lg.	471-069
	5	5	5	5	WASHER, Lock: external tooth, No.6	502-014
	1	1	1	1	BRACKET, Mounting	Not available
	1	1	1	1	SWITCH ASSEMBLY, Power and speed control	4040724-10
	2	2	2	2	SPRING, Pushbutton	4270208-10
	3	3	3	3	HOLDER, Pilot lamp	150-045
	3	3	3	3	SCREW, Machine: pan head, Phillips drive, 6-32 by 1/4 in. lg.	471-067
	3	3	3	3	WASHER, Lock: external tooth, No.6	502-014
	1	1	1	1	INSULATOR, Switch	4170265-10
	2	2	2	2	SCREW, Self-tapping: hex washer head, slot drive, #6 by 1/4 in. lg.	476-998
S502	4	4	4	4	SWITCH, Lever: subminiature, SPDT, Cherry E-62-10H	120-398
	2	2	2	2	INSULATOR, Switch	4170263-10
	2	2	2	2	SCREW, Machine: pan head, Phillips drive, 2-56 by 1-3/8 in. lg.	472-898
	2	2	2	2	WASHER, Lock: internal tooth, No.2	502-023
	2	2	2	2	NUT, Hex: 2-56	492-007
S501	2	2	2	2	SWITCH, Lever: subminiature, SPDT, Cherry E-62-10H	120-398
	1	1	1	1	INSULATOR, Switch	4170263-10
	2	2	2	2	SCREW, Machine: pan head, Phillips drive, 2-56 by 7/8 in. lg.	472-459
	2	2	2	2	WASHER, Lock: internal tooth, No.2	502-023
	2	2	2	2	NUT, Hex: 2-56	492-007
	1	1	1	1	INSULATOR, Switch	4170264-10
	1	1	1	1	BRACKET, Mounting	Not available
P510	1	1	1	1	CONNECTOR, Plug: female, 4 contacts, Jones S-304-CCT-L	144-032
	2	2	2	2	CONNECTOR, Solderless: disconnect splice	171-008
	1	1	1	1	FANNING STRIP, Terminal: 8 position, Kulka 649-8	185-136
	1	1	1	1	CONTROL BOX ASSEMBLY	4050332-10
*	1	1	1	1	BIAS OSCILLATOR ASSEMBLY	4020237-01
	1	1	1	1	BRACKET ASSEMBLY, Oscillator	4050335-10
CR502	4	4	4	4	RECTIFIER, Silicon: 10 amp	580-035
CR503	-	-	-	-	(Same as CR502)	580-035
CR504	-	-	-	-	(Same as CR502)	580-035
CR505	-	-	-	-	(Same as CR502)	580-035
	2	2	2	2	BRACKET, Rectifier	4260238-10
	2	2	2	2	SCREW, Self-tapping: hex washer head, slot drive, #6 by 1/4 in. lg.	476-011
	1	1	1	1	FASTENER, Oscillator mounting	310-162
J501	1	1	1	1	CONNECTOR, Receptacle: female, 15 contacts, Cannon DA-15S	146-020
	2	2	2	2	SCREW, Self-tapping: hex washer head, slot drive, #4 by 3/16 in. lg.	476-185
	1	1	1	1	BRACKET, Oscillator	4260308-10
	1	1	1	1	ETCHED BOARD ASSEMBLY, Control box	4050333-10
C501	1	1	1	1	CAPACITOR, Electrolytic: 30 mfd, 250 vdcw, Sprague type DEE	031-468
C503	6	6	6	6	CAPACITOR, Mylar: 0.047 mfd, ±10%, 400 vdcw, El Menco 4 DP-3-473	035-764
C504	2	2	2	2	CAPACITOR, Mylar: 0.0047 mfd, ±10%, 600 vdcw, El Menco 6 DP-1-472	035-768
C505	-	-	-	-	(Same as C504)	035-768
C507	4	4	4	4	CAPACITOR, Mylar: 0.22 mfd, ±10%, 400 vdcw, El Menco 4 DP-5-224	035-766
C508	-	-	-	-	(Same as C503)	035-764
C510	2	2	2	2	CAPACITOR, Mylar: 0.1 mfd, ±10%, 400 vdcw, El Menco 4 DP-3-104	035-765
C511	1	1	1	1	CAPACITOR, Mylar: 0.5 mfd, ±10%, 400 vdcw, El Menco 4 DP-6-504	035-779

* See separate parts list later in this section.

TAPE TRANSPORT - 1/2" TAPE (CONTINUED)

Ref. Sym.	4020244				DESCRIPTION	Ampex Part Number
	-05	-06	-07	-08		
C514	-	-	-	-	(Same as C503)	035-764
C515	-	-	-	-	(Same as C510)	035-765
C516	-	-	-	-	(Same as C507)	035-766
C517	-	-	-	-	(Same as C503)	035-764
C518	-	-	-	-	(Same as C503)	035-764
C519	-	-	-	-	(Same as C507)	035-766
C520	-	-	-	-	(Same as C507)	035-766
C521	-	-	-	-	(Same as C503)	035-764
CR501	3	3	3	3	DIODE, Crystal: diffused silicon, Type 1N2864	013-339
CR506	11	11	11	11	DIODE, Crystal: diffused silicon, Type 1N2863	580-027
CR507	-	-	-	-	(Same as CR506)	580-027
CR508	-	-	-	-	(Same as CR506)	580-027
CR509	-	-	-	-	(Same as CR506)	580-027
CR510	-	-	-	-	(Same as CR506)	580-027
CR511	-	-	-	-	(Same as CR506)	580-027
CR512	-	-	-	-	(Same as CR506)	580-027
CR513	-	-	-	-	(Same as CR506)	580-027
CR514	-	-	-	-	(Same as CR506)	580-027
CR515	-	-	-	-	(Same as CR506)	580-027
CR516	-	-	-	-	(Same as CR506)	580-027
CR517	-	-	-	-	(Same as CR501)	013-339
CR518	-	-	-	-	(Same as CR501)	013-339
R502	1	1	1	1	RESISTOR, Fixed: wirewound, 150 ohms, ±5%, 10 W	047-660
R503	2	2	2	2	RESISTOR, Fixed: composition, 10 ohms, ±10%, 1/2 W	041-032
R504	1	1	1	1	RESISTOR, Fixed: composition, 150 ohms, ±10%, 1/2 W	041-241
R505	9	9	9	9	RESISTOR, Fixed: composition, 100 ohms, ±10%, 1/2 W	041-038
R506	1	1	1	1	RESISTOR, Fixed: composition, 820 ohms, ±10%, 1/2 W	041-047
R509	1	1	1	1	RESISTOR, Fixed: wirewound, 33 ohms, ±10%, 2 W	047-654
R510	-	-	-	-	(Same as R505)	041-038
R511	2	2	2	2	RESISTOR, Fixed: wirewound, 2 ohms, ±5%, 10 W	047-655
R512	-	-	-	-	(Same as R511)	047-655
R513	-	-	-	-	(Same as R505)	041-038
R519	2	2	2	2	RESISTOR, Fixed: wirewound, 15 ohms, ±5%, 10 W	047-658
R520	4	4	4	4	RESISTOR, Fixed: wirewound, 5 ohms, ±5%, 10 W	047-656
R521	2	2	2	2	RESISTOR, Fixed: wirewound, 40 ohms, ±5%, 10 W	047-659
R522	-	-	-	-	(Same as R520)	047-656
R523	-	-	-	-	(Same as R520)	047-656
R524	-	-	-	-	(Same as R521)	047-659
R525	-	-	-	-	(Same as R520)	047-656
R526	-	-	-	-	(Same as R519)	047-658
R527	-	-	-	-	(Same as R505)	041-038
R528	-	-	-	-	(Same as R505)	041-038
R529	-	-	-	-	(Same as R505)	041-028
R530	1	1	1	1	RESISTOR, Fixed: wirewound, 10 ohms, ±5%, 10 W	047-657
R531	-	-	-	-	(Same as R503)	041-032
R532	1	1	1	1	RESISTOR, Fixed, wirewound, 500 ohms, ±5%, 10 W	047-815
R533	1	1	1	1	RESISTOR, Fixed: composition, 22 ohms, ±10%, 1/2 W	041-033
R534	-	-	-	-	(Same as R505)	041-038
R535	-	-	-	-	(Same as R505)	041-038
R536	1	1	1	1	RESISTOR, Fixed: wirewound, 700 ohms, ±5%, 10 W	047-661
R537	-	-	-	-	(Same as R505)	041-038
RV501	4	4	4	4	VARISTOR, Silicon carbide, 24 vdc	046-092
RV502	-	-	-	-	(Same as RV501)	046-092
RV503	-	-	-	-	(Same as RV501)	046-092
RV504	-	-	-	-	(Same as RV501)	046-092
C502	1	1	1	1	CAPACITOR, Electrolytic: 2000-750 mfd, 50 vdcw	4550145-20
C509	1	1	1	1	CAPACITOR, Electrolytic: 500-300-200-100 mfd	4550145-40
C512	1	1	1	1	CAPACITOR, Electrolytic: 1000 mfd, 100 vdcw	4550145-30
C513	1	1	1	1	CAPACITOR, Electrolytic: 500 mfd, 200 vdcw	4550145-10
F501	2	2	2	2	FUSE, Cartridge: 5 amp, 125v, slow blow, Littelfuse 313005 (115v operation)	070-020
F501	3	3	3	3	FUSE, Cartridge: 3 amp, 250v, fast blow, Littelfuse 312003 (230v operation)	070-001
F502	-	-	-	-	(Same as F501) (115v operation)	070-020
F502	-	-	-	-	(Same as F501) (230v operation)	070-001
F503	1	1	1	1	FUSE, Cartridge: 3 amp, 125v, slow blow, Littelfuse 313003 (115v operation)	070-002
F503	1	1	1	1	FUSE, Cartridge: 2 amp, 250v, fast blow, Littelfuse 312002 (230v operation)	070-016
F504	-	-	-	-	(Same as F501)	070-001
F505	1	1	1	1	FUSE, Cartridge: 1 amp, 125v, slow blow, Littelfuse 313001	070-004
J502	1	1	1	1	CONNECTOR, Receptacle: male, 3 contact, MS3102A10SL-3P	143-008

TAPE TRANSPORT - 1/2" TAPE (CONTINUED)

Ref. Sym.	4020244				DESCRIPTION	Ampex Part Number
	-05	-06	-07	-08		
J503	1	1	1	1	CONNECTOR, Receptacle: female, 6 contact, Jones S-306-AB	146-004
J504	1	1	1	1	CONNECTOR, Receptacle: male, 3 contact, Hubbell 7556G	147-052
J505	1	1	1	1	CONNECTOR, Receptacle: female, 2 contact, Despard 1320 & 1354	146-014
J506	4	4	4	4	CONNECTOR, Receptacle: female, 8 contact, Jones S-308-AB	146-003
J507	1	1	1	1	CONNECTOR, Receptacle: female, 12 contact, Jones S-312-AB	146-009
J508	1	1	1	1	CONNECTOR, Receptacle: female, 4 contact, Jones S-304-AB	146-005
J509	1	1	1	1	CONNECTOR, Receptacle: female, 10 contact, Jones S-310-AB	146-018
J511	-	-	-	-	(Same as J506)	146-003
J512	-	-	-	-	(Same as J506)	146-003
J513	-	-	-	-	(Same as J506)	146-003
K501	2	2	2	2	RELAY, 4 circuit	4590101-20
K502	-	-	-	-	(Same as K501)	4590101-20
K503	3	3	3	3	RELAY, 6 circuit	4590101-30
K504	2	2	2	2	RELAY, 2 circuit	4590101-10
K505	-	-	-	-	(Same as K503)	4590101-30
K506	-	-	-	-	(Same as K503)	4590101-30
K507	-	-	-	-	(Same as K504)	4590101-10
L501	1	1	1	1	CHOKER, Filter	4580174-10
P506	1	1	1	1	DUMMY PLUG ASSEMBLY, Capstan motor amplifier	4050138-20
P507	1	1	1	1	DUMMY PLUG ASSEMBLY, Remote control	4050371-01
R501	1	1	1	1	RESISTOR, Variable: 50K ohms	4520145-40
R507	1	1	1	1	RESISTOR, Fixed: composition, 470 ohms, ±10%, 2 W	041-199
R508	1	1	1	1	RESISTOR, Variable: 5000 ohms	4520150-10
R514	1	1	1	1	RESISTOR, Fixed: composition, 6800 ohms, ±10%, 1 W	041-156
S503	1	1	1	1	SWITCH, Line voltage adjust	4620177-10
T501	1	1	1	1	TRANSFORMER, Power	4580179-10
	5	5	5	5	HOLDER, Fuse: Littelfuse 342012	085-001
	1	1	1	1	KNOB	4100105-02
	1	1	1	1	SHIELD, Transformer	4290550-01
DS501	8	8	8	8	LAMP, Incandescent: miniature, bayonet, 24v, 0.07 amp, G.E. type 1829	060-011
DS502	-	-	-	-	(Same as DS501)	060-011
DS503	-	-	-	-	(Same as DS501)	060-011
DS504	-	-	-	-	(Same as DS501)	060-011
DS505	-	-	-	-	(Same as DS501)	060-011
DS506	-	-	-	-	(Same as DS501)	060-011
DS507	-	-	-	-	(Same as DS501)	060-011
DS508	-	-	-	-	(Same as DS501)	060-011

TAPE TRANSPORT - 1" TAPE

Ref. Sym.	4020244				DESCRIPTION	Ampex Part Number
	-09	-10	-11	-12		
P503	X				TAPE TRANSPORT, 7-1/2 - 15 ips, 60 cps	4020244-09
		X			TAPE TRANSPORT, 15 - 30 ips, 60 cps	4020244-10
			X		TAPE TRANSPORT, 7-1/2 - 15 ips, 50 cps	4020244-11
				X	TAPE TRANSPORT, 15 - 30 ips, 50 cps	4020244-12
	1				DRIVE MOTOR AND BRACKET ASSEMBLY	4030206-10
		1			DRIVE MOTOR AND BRACKET ASSEMBLY	4030206-20
			1		DRIVE MOTOR AND BRACKET ASSEMBLY	4030206-30
				1	DRIVE MOTOR AND BRACKET ASSEMBLY	4030206-40
	1				MOTOR ASSEMBLY, Drive	4030197-10
		1			MOTOR ASSEMBLY, Drive	4030197-20
			1		MOTOR ASSEMBLY, Drive	4030197-30
				1	MOTOR ASSEMBLY, Drive	4030197-40
	1	1	1	1	PULLEY, Drive motor	Not available
	1	1	1	1	MOTOR, Drive	Not available
	1	1	1	1	CONNECTOR, Plug: male, 6 contact, Jones P-306-CCT	145-004
	1	1	1	1	PLATE, Drive motor mounting	4330247-01
	4	4	4	4	SCREW, Machine: flat head, Phillips drive, 10-24 by 1/2 in. lg.	471-734
	1	1	1	1	RING, Retaining: external, beveled, Truarc 5102-231-MD	430-366
	1	1	1	1	MOUNTING BRACKET ASSEMBLY, Drive motor	4030205-10
	1	1	1	1	BRACKET, Support: motor mounting	4260296-10
	1	1	1	1	BRACKET, Mounting: motor	4260299-10
	1	1	1	1	STOP, Drive motor	4220192-10
	1	1	1	1	WASHER, Lock: split ring; 1/4 in.	502-006
	1	1	1	1	SHAFT	4210175-10
	2	2	2	2	BEARING, Ball: Fafnir A38KDD	421-083
	2	2	2	2	RING, Retaining: internal, flat, Truarc N5000-86-S-ZD	430-028
	a/r	a/r	a/r	a/r	WASHER, Shim: 0.005 in. thk.	4440113-10
	a/r	a/r	a/r	a/r	WASHER, Shim: 0.015 in. thk.	4440113-30
	2	2	2	2	SCREW, Set: headless, socket drive, 8-32 by 1/4 in. lg.	477-041
	1	1	1	1	BEARING, Ball: Fafnir B546FS171	421-228
	4	4	4	4	SCREW, Machine: pan head, Phillips drive, 6-32 by 3/8 in. lg.	471-069
	4	4	4	4	NUT, Hex: 6-32	492-009
	4	4	4	4	WASHER, Lock: external tooth, No.6	502-014
	1	1	1	1	CAPACITOR ASSEMBLY, Motor	4050336-10
	1	1	1	1	CAPACITOR, Motor	4540292-30
	1	1	1	1	BOOT, Safety: Sprague 301-66	032-082
	2	2	2	2	CONNECTOR, Solderless: slotted ring, Amp 328394	171-360
	2	2	2	2	SCREW, Machine: pan head, Phillips drive, 10-24 by 5/8 in. lg.	471-865
	2	2	2	2	WASHER, Flat: No.10	501-011
	2	2	2	2	WASHER, Lock: external tooth, No.10	502-016
1	1	1	1	ACTUATOR ASSEMBLY, Drive motor	4030204-10	
1	1	1	1	ACTUATOR ASSEMBLY, Drive motor	4030204-20	
1	1	1	1	SOLENOID ASSEMBLY	4030202-20	
1	1	1	1	SOLENOID	4590106-10	
1	1	1	1	BOLT, Eye	4400496-90	
1	1	1	1	PIN, Clevis: 1/8 in. dia. by 17/32 in. lg.	400-009	
1	1	1	1	PIN, Cotter: 1/16 in. dia. by 1/2 in. lg.	401-005	
1	1	1	1	WASHER, Felt: 1/2 in. OD by 1/4 in. ID by 1/4 in. thk.	503-015	
1	1	1	1	STOP, Solenoid	4220139-20	
2	2	2	2	SCREW, Machine: pan head, Phillips drive 8-32 by 1/4 in. lg.	471-076	
2	2	2	2	WASHER, Lock: external tooth, No.8	502-068	
2	2	2	2	CONNECTOR, Solderless: slotted ring, Amp 328394	171-360	
1	1	1	1	PLATE, Solenoid adapter	4330195-10	
4	4	4	4	SCREW, Machine: flat head, Phillips drive, 8-32 by 1/4 in. lg.	471-343	
1	1	1	1	STOP, Drive motor	4220196-10	
1	1	1	1	STOP, Drive motor	4220224-10	
1	1	1	1	ANCHOR, Motor return spring	4260295-10	
2	2	2	2	SCREW, Machine: pan head, Phillips drive, 8-32 by 1/2 in. lg.	471-080	
2	2	2	2	WASHER, Flat: No.8	501-911	
2	2	2	2	WASHER, Lock: external tooth, No.8	502-015	
1	1	1	1	PAD	4130150-10	
1	1	1	1	SCREW, Set: headless, socket drive, 10-32 by 3/4 in. lg.	477-340	
1	1	1	1	NUT, Hex: 10-32	492-011	
2	2	2	2	SCREW, Machine: pan head, Phillips drive, 10-24 by 5/8 in. lg.	471-865	
2	2	2	2	WASHER, Lock: external tooth, No.10	502-016	
1	1	1	1	ANGLE, Drive motor actuator	4260294-10	
				ANGLE, Drive motor actuator	4260311-10	
				ANGLE, Drive motor actuator	4260312-10	

TAPE TRANSPORT - 1" TAPE (CONTINUED)

Ref. Svm.	4020244				DESCRIPTION	Ampex Part Number	
	-09	-10	-11	-12			
K508	1	1	1	1	SCREW, Set: headless, socket drive, 1/4-28 by 1-3/4 in. lg.	477-339	
	1	1	1	1	NUT, Hex: 1/4 - 28	492-037	
	4	4	4	4	SCREW, Machine: pan head, Phillips drive, 10-24 by 5/8 in. lg.	471-865	
	4	4	4	4	WASHER, Lock: external tooth, No.10	502-016	
	1	1	1	1	SHIELD, Motor	4290516-10	
	1	1	1	1	PAD, Shield spacer	4130166-10	
	1	1	1	1	CLAMP, Shield	300-096	
	2	2	2	2	MOUNT, Isolation spring	4260390-01	
	3	3	3	3	SPRING, Isolation and actuator return	4270222-10	
	1	1	1	1	PIN, Clevis: 1/8 in. dia. by 17/32 in. lg.	400-009	
	1	1	1	1	SPRING, Actuator solenoid return	4270162-10	
	1	1	1	1	NUT, Hex: self locking, 10-32	493-008	
	1	1	1	1	STOP, Solenoid	4220200-10	
	2	2	2	2	SCREW, Machine: pan head, Phillips drive, 8-32 by 1/4 in. lg.	471-076	
	2	2	2	2	WASHER, Lock: external tooth, No.8	502-015	
	1	1	1	1	WASHER, Felt: 1/2 in. OD by 1/4 in. ID by 1/4 in. thk.	503-015	
	1	1	1	1	PIN, Clevis: 1/8 in. dia. by 17/32 in. lg.	400-009	
	1	1	1	1	PIN, Cotter: 1/16 in. dia. by 1/2 in. lg.	401-005	
	2	2	2	2	WASHER, Flat: No.4	501-008	
	1	1	1	1	BOLT, Eye	4400612-10	
	1	1	1	1	DRAWBAR, Capstan solenoid	4210241-10	
	2	2	2	2	PIN, Roll: stainless steel, 1/8 in. dia. by 5/8 in. lg.	406-030	
	2	2	2	2	SOLENOID	4590063-10	
	8	8	8	8	SCREW, Machine: pan head, Phillips drive, 8-32 by 1/2 in. lg.	471-080	
	8	8	8	8	WASHER, Lock: external tooth, No.8	502-015	
	S505	1	1	1	1	SWITCH, Lever: subminiature, SPDT, Cherry E-61-10H	120-436
		1	1	1	1	INSULATOR, Switch	4170204-10
		2	2	2	2	SCREW, Machine: pan head, Phillips drive, 2-56 by 1/2 in. lg.	472-456
		2	2	2	2	WASHER, Flat: No.2	501-202
		2	2	2	2	WASHER, Lock: split ring, No.2	502-094
		1	1	1	1	STRIP, Terminal: barrier, 8 terminals, Kulka 410-8	180-453
		4	4	4	4	SCREW, Machine: pan head, Phillips drive, 2-56 by 1/2 in. lg.	472-456
		4	4	4	4	WASHER, Lock: split ring, No.2	502-094
		6	6	6	6	CONNECTOR, Solderless: slotted ring, Amp 328394	171-360
		1	1	1	1	REEL IDLER ASSEMBLY	4030200-30
		1	1	1	1	BRAKE ASSEMBLY	4030201-10
		1	1	1	1	HOUSING, Brake	4330112-10
		1	1	1	1	BAND, Brake	4040414-10
		1	1	1	1	SPRING, Leaf: brake band	4270164-10
		2	2	2	2	SPRING, Tension: short	4270163-10
		1	1	1	1	SPRING, Tension: long	4270211-10
		1	1	1	1	BOLT, Eye	4400496-60
		2	2	2	2	NUT, Hex: 10-32	492-011
		1	1	1	1	CROSSHEAD, Brake	4330109-10
		2	2	2	2	SCREW, Machine: flat head, Phillips drive, 6-32 by 1-1/8 in. lg.	471-719
4		4	4	4	WASHER, Finishing: No.6	506-001	
2		2	2	2	WASHER, Flat: No.6	501-009	
2		2	2	2	SPACER	4220141-10	
2		2	2	2	NUT, Hex: self locking, 6-32	493-006	
1		1	1	1	ANCHOR	4330110-10	
2	2	2	2	SCREW, Sem: pan head, Phillips drive, 6-32 by 5/16 in. lg.	475-085		
1	1	1	1	PIN, Roll: 1/8 in. dia. by 3/4 in. lg.	406-005		
2	2	2	2	LINK, Brake band	4230161-10		
4	4	4	4	SCREW, Machine: cap, socket drive, 4-40 by 3/16 in. lg.	470-007		
4	4	4	4	WASHER, Lock: split ring, No.4	502-002		
2	2	2	2	CLAMP, Band link	4330113-10		
1	1	1	1	LEVER, Brake	4230162-10		
2	2	2	2	PIN, Drivelock: 1/8 in. dia. by 1/2 in. lg.	403-008		
1	1	1	1	PIN, Clevis: 1/8 in. dia. by 9/32 in. lg.	400-002		
1	1	1	1	PIN, Cotter: 1/16 in. dia. by 1/2 in. lg.	401-005		
1	1	1	1	STOP, Solenoid	4260184-10		
2	2	2	2	SCREW, Sem: pan head, Phillips drive, 8-32 by 1/4 in. lg.	475-072		
2	2	2	2	LINK, Solenoid	4230163-10		
1	1	1	1	PIN, Clevis: 1/8 in. dia. by 15/32 in. lg.	400-007		
1	1	1	1	PIN, Cotter: 1/16 in. dia. by 1/2 in. lg.	401-005		
1	1	1	1	BRACKET, Solenoid	4260310-10		
2	2	2	2	SCREW, Sem: pan head, Phillips drive, 8-32 by 3/8 in. lg.	475-044		
K510	1	1	1	SOLENOID	4590102-10		

TAPE TRANSPORT - 1" TAPE (CONTINUED)

Ref. Sym.	4020244				DESCRIPTION	Ampex Part Number	
	-09	-10	-11	-12			
C522	2	2	2	2	SCREW, Sem: pan head, Phillips drive, 8-32 by 1/4 in. lg.	475-072	
	2	2	2	2	CONNECTOR, Solderless: disconnect splice	171-008	
	3	3	3	3	SCREW, Machine: pan head, Phillips drive, 6-32 by 1/2 in. lg.	471-071	
	3	3	3	3	WASHER, Lock: external tooth, No.6	502-014	
	1	1	1	1	MOTOR ASSEMBLY, Torque	4040731-30	
	1	1	1	1	PULLEY, Reel idler	4250159-30	
	1	1	1	1	SCREW, Set: headless, socket drive, 8-32 by 3/8 in. lg.	477-043	
	1	1	1	1	ADAPTER, Motor mounting	4220197-10	
	4	4	4	4	SCREW, Machine: pan head, Phillips drive. 6-32 by 1/2 in. lg.	475-034	
	4	4	4	4	WASHER, Lock: external tooth, No.8	502-014	
	1	1	1	1	DRUM, Brake	Not available	
	1	1	1	1	PIN, Roll: 3/32 in. dia. by 3/4 in. lg.	406-006	
	1	1	1	1	MOTOR, Torque	Not available	
	1	1	1	1	CAPACITOR ASSEMBLY, Motor	4050336-20	
	1	1	1	1	CAPACITOR, Motor	4540292-30	
	1	1	1	1	BOOT, Safety: Sprague 301-66	032-082	
	2	2	2	2	CONNECTOR, Solderless: disconnect splice	171-008	
	2	2	2	2	WASHER, Flat: No.8	501-010	
	P511	1	1	1	1	CONNECTOR, Plug: male, 8 contact, Jones P-308-CCT-L	145-013
		4	4	4	4	CONNECTOR, Solderless: knife disconnect	171-008
		1	1	1	1	TAKEUP ASSEMBLY	4030226-30
		1	1	1	1	BRAKE ASSEMBLY	4030114-60
		1	1	1	1	HOUSING, Brake	4330112-10
		1	1	1	1	BAND, Brake	4040414-10
		1	1	1	1	SPRING, Leaf: brake band	4270164-10
		2	2	2	2	SPRING, Tension: short	4270163-10
		1	1	1	1	SPRING, Tension: long	4270178-10
		1	1	1	1	BOLT, Eye	4400496-60
2		2	2	2	NUT, Hex: 10-32	492-011	
1		1	1	1	CROSSHEAD, Brake	4330109-10	
2		2	2	2	SCREW, Machine: flat head, Phillips drive, 6-32 by 1-3/8 in. lg.	472-890	
4		4	4	4	WASHER, Finishing: No.6	506-001	
2		2	2	2	SPACER	4220141-10	
2		2	2	2	NUT, Hex: self locking, 6-32	493-006	
1		1	1	1	ANCHOR	4330110-10	
2		2	2	2	SCREW, Sem: pan head, Phillips drive, 6-32 by 5/16 in. lg.	475-085	
1		1	1	1	PIN, Roll: 1/8 in. dia. by 7/8 in. lg.	406-042	
2		2	2	2	LINK, Brake band	4230161-10	
4		4	4	4	SCREW, Machine: cap, socket drive, 4-40 by 3/16 in. lg.	470-007	
4		4	4	4	WASHER, Lock: split ring, No.4	502-002	
2		2	2	2	CLAMP, Band link	4330113-10	
1		1	1	1	LEVER, Brake	4230162-10	
2		2	2	2	PIN, Drivelock: 1/8 in. dia. by 1/2 in. lg.	403-008	
1		1	1	1	PIN, Clevis: 1/8 in. dia. by 9/32 in. lg.	400-002	
1		1	1	1	PIN, Cotter: 1/16 in. dia. by 1/2 in. lg.	401-005	
1		1	1	1	STOP, Solenoid	4260184-10	
2	2	2	2	SCREW, Sem: pan head, Phillips drive, 8-32 by 1/4 in. lg.	475-072		
2	2	2	2	LINK, Solenoid	4230163-10		
1	1	1	1	PIN, Clevis: 1/8 in. dia. by 15/32 in. lg.	400-007		
1	1	1	1	PIN, Cotter: 1/16 in. dia. by 1/2 in. lg.	401-005		
1	1	1	1	BRACKET, Solenoid	4260183-10		
2	2	2	2	SCREW, Sem: pan head, Phillips drive, 8-32 by 3/8 in. lg.	475-044		
K512	1	1	1	1	SOLENOID	4590067-10	
	2	2	2	2	SCREW, Sem: pan head, Phillips drive, 8-32 by 1/4 in. lg.	475-072	
	2	2	2	2	CONNECTOR, Solderless: disconnect splice	171-008	
	3	3	3	3	SCREW, Machine: pan head, Phillips drive, 6-32 by 1/2 in. lg.	471-071	
	3	3	3	3	WASHER, Lock: external tooth, No.6	502-014	
	1	1	1	1	CAPACITOR ASSEMBLY, Motor	4050361-10	
	C524	1	1	1	1	CAPACITOR, Motor	4540312-10
		1	1	1	1	BOOT, Safety: Sprague	032-082
		2	2	2	2	CONNECTOR, Solderless: disconnect splice	171-008
		1	1	1	1	DRIVE PLATE, Reel: with EIA drive pins	4320128-10
		3	3	3	3	SCREW, Machine: button head, 4-40 by 3/16 in. lg.	470-382
		1	1	1	1	PAD, Turntable	4130152-10
		1	1	1	1	TURNTABLE	4250160-10
		1	1	1	1	SHIM, Turntable	4280125-10
		3	3	3	3	SCREW, Machine: button head, 8-32 by 1/2 in. lg.	470-384
		1	1	1	1	SHIELD, Motor	4290516-30

TAPE TRANSPORT - 1" TAPE (CONTINUED)

Ref. Sym.	4020244				DESCRIPTION	Ampex Part Number
	-09	-10	-11	-12		
P513	1	1	1	1	CLAMP, Shield	300-096
	1	1	1	1	MOTOR ASSEMBLY, Torque	4040797-20
	1	1	1	1	HUB, Turntable	Not available
	1	1	1	1	PIN, Roll: 3/32 in. dia. by 3/4 in. lg.	406-006
	1	1	1	1	ADAPTER, Motor mounting	4220197-10
	4	4	4	4	SCREW, Machine: pan head, Phillips drive, 6032 by 1/2 in. lg.	471-071
	4	4	4	4	WASHER, Lock: external tooth, No.6	502-014
	1	1	1	1	DRUM, Brake	Not available
	1	1	1	1	PIN, Roll: 3/32 in. dia. by 3/4 in. lg.	406-006
	1	1	1	1	MOTOR, Torque	Not available
	1	1	1	1	CONNECTOR, Plug: male, 8 contact, Jones P-308-CCT-L	145-013
	4	4	4	4	CONNECTOR, Solderless: disconnect splice	171-008
	1	1	1	1	REWIND ASSEMBLY	4030227-30
	1	1	1	1	BRAKE ASSEMBLY	4030114-50
	1	1	1	1	HOUSING, Brake	4330112-10
	1	1	1	1	BAND, Brake	4040414-10
	1	1	1	1	SPRING, Leaf: brake band	4270164-10
	2	2	2	2	SPRING, Tension: short	4270163-10
	1	1	1	1	SPRING, Tension: long	4270178-10
	1	1	1	1	BOLT, Eye	4400496-60
	2	2	2	2	NUT, Hex: 10-32	492-011
	1	1	1	1	CROSSHEAD, Brake	4330109-10
	2	2	2	2	SCREW, Machine: flat head, Phillips drive, 6-32 by 1-3/8 in. lg.	472-890
	4	4	4	4	WASHER, Finishing: No.6	506-001
	2	2	2	2	SPACER	4220141-10
	2	2	2	2	NUT, Hex: self locking, 6-32	493-006
	1	1	1	1	ANCHOR	4330110-10
	2	2	2	2	SCREW, Sem: pan head, Phillips drive, 6-32 by 5/16 in. lg.	475-085
	1	1	1	1	PIN, Roll: 1/8 in. dia. by 7/8 in. lg.	406-042
	2	2	2	2	LINK, Brake band	4230161-10
	4	4	4	4	SCREW, Machine: cap, socket drive, 4-40 by 3/16 in. lg.	470-007
	4	4	4	4	WASHER, Lock: split ring, No.4	502-002
	2	2	2	2	CLAMP, Band link	4330113-10
	1	1	1	1	LEVER, Brake	4230162-10
	2	2	2	2	PIN, Drivelock: 1/8 in. dia. by 1/2 in. lg.	403-008
	1	1	1	1	PIN, Clevis: 1/8 in. dia. by 9/32 in. lg.	400-002
	1	1	1	1	PIN, Cotter: 1/16 in. dia. by 1/2 in. lg.	401-005
	1	1	1	1	STOP, Solenoid	4260184-10
	2	2	2	2	SCREW, Sem: pan head, Phillips drive, 8-32 by 1/4 in. lg.	475-072
	2	2	2	2	LINK, Solenoid	4230163-10
	1	1	1	1	PIN, Clevis: 1/8 in. dia. by 15/32 in. lg.	400-007
	1	1	1	1	PIN, Cotter: 1/16 in. dia. by 1/2 in. lg.	401-005
	1	1	1	1	BRACKET, Solenoid	4260183-10
	2	2	2	2	SCREW, Sem: pan head, Phillips drive, 8-32 by 3/8 in. lg.	475-044
	1	1	1	1	SOLENOID	4590067-10
2	2	2	2	SCREW, Sem: pan head, Phillips drive, 8-32 by 1/4 in. lg.	475-072	
2	2	2	2	CONNECTOR, Solderless: disconnect splice	171-008	
3	3	3	3	SCREW, Machine: pan head, Phillips drive, 6-32 by 1/2 in. lg.	471-071	
3	3	3	3	WASHER, Lock: external tooth, No.6	502-014	
1	1	1	1	CAPACITOR ASSEMBLY, Motor	4050361-10	
1	1	1	1	CAPACITOR, Motor	4540312-10	
1	1	1	1	BOOT, Safety: Sprague	032-082	
2	2	2	2	CONNECTOR, Solderless: disconnect splice	171-008	
1	1	1	1	DRIVE PLATE, Reel: with EIA drive pins	4320128-10	
3	3	3	3	SCREW, Machine: button head, 4-40 by 3/16 in. lg.	470-382	
1	1	1	1	PAD, Turntable	4130152-10	
1	1	1	1	TURNTABLE	4250160-10	
1	1	1	1	SHIM, Turntable	4280125-10	
3	3	3	3	SCREW, Machine: button head, 8-32 by 1/2 in. lg.	470-384	
1	1	1	1	SHIELD, Motor	4290516-30	
1	1	1	1	CLAMP, Shield	300-096	
1	1	1	1	MOTOR ASSEMBLY, Torque	4040797-20	
1	1	1	1	HUB, Turntable	Not available	
1	1	1	1	PIN, Roll: 3/32 in. dia. by 3/4 in. lg.	406-006	
1	1	1	1	ADAPTER, Motor mounting	4220197-10	
4	4	4	4	SCREW, Machine: pan head, Phillips drive, 6-32 by 1/2 in. lg.	471-071	
4	4	4	4	WASHER, Lock: external tooth, No.6	502-014	
1	1	1	1	DRUM, Brake	Not available	

TAPE TRANSPORT - 1" TAPE (CONTINUED)

Ref. Sym.	4020244				DESCRIPTION	Ampex Part Number
	-09	-10	-11	-12		
P512	1	1	1	1	PIN, Roll: 3/32 in. dia. by 3/4 in. lg.	406-006
	1	1	1	1	MOTOR, Torque	Not available
	1	1	1	1	CONNECTOR, Plug: male, 8 contact, Jones P-308-CCT-L	145-013
	4	4	4	4	CONNECTOR, Solderless: disconnect splice	171-008
	1	1	1	1	FLYWHEEL ASSEMBLY, Damped	4030196-10
	1	1	1	1	CAP, Capstan	4100167-10
	1	1	1	1	SCREW, Set: headless, socket drive, 8-32 by 1/8 in. lg.	477-348
	1	1	1	1	CAPSTAN ASSEMBLY	4030199-20
	1	1	1	1	FLYWHEEL	Not available
	1	1	1	1	PIN, Roll: 5/32 in. dia. by 1-1/4 in. lg.	406-007
	a/r	a/r	a/r	a/r	WASHER, Shim: 0.625 in. OD by 0.500 in. ID by 0.003 in. thk.	501-050
	1	1	1	1	SEAL, Dust	4440247-10
	1	1	1	1	RING, Retaining: internal, bowed, Truarc 5001-125-S	430-064
	1	1	1	1	BEARING, Ball	Not available
	1	1	1	1	SHAFT, Capstan	Not available
	1	1	1	1	HOUSING ASSEMBLY, Capstan	Not available
	1	1	1	1	IDLER ASSEMBLY, Capstan	4030203-30
	1	1	1	1	CAP, Capstan idler	4100166-10
	1	1	1	1	RING, Lock	4320112-10
	1	1	1	1	RING, Retaining: external, flat, Truarc 5100-25-S	430-004
	a/r	a/r	a/r	a/r	WASHER, Shim: 0.437 in. OD by 0.250 in. ID by 0.002 in. thk.	501-049
	1	1	1	1	WASHER, Flat	4440239-10
	1	1	1	1	SHAFT, Capstan idler	Not available
	1	1	1	1	WASHER, Thrust	4440027-10
	1	1	1	1	WHEEL ASSEMBLY, Capstan idler	4040404-80
	1	1	1	1	SCREW, Set: headless, socket drive, 8-32 by 1/8 in. lg.	477-348
	1	1	1	1	POST ASSEMBLY, Tape turnaround	4040741-20
	1	1	1	1	SCREW, Set: headless, socket drive, 8-32 by 1/8 in. lg.	477-348
	1	1	1	1	NUT, Hex: self lock, 10-32	493-008
	1	1	1	1	SPRING, Solenoid pressure: capstan idler	4270162-10
	1	1	1	1	SPRING, Solenoid return: capstan idler	4270229-10
	1	1	1	1	ARM, Solenoid: capstan idler	4230212-10
	1	1	1	1	PIN, Roll: 1/8 in. dia. by 3/4 in. lg.	406-005
	1	1	1	1	ARM, Capstan idler	4230204-10
	1	1	1	1	BEARING, Capstan idler	Not available
	3	3	3	3	SCREW, Machine: cap. socket drive, 8-32 by 1/2 in. lg.	470-029
	1	1	1	1	DAMPER ASSEMBLY, Capstan idler	4040851-10
	1	1	1	1	SPRING, Dashpot arm	4270238-10
	1	1	1	1	PIN, Clevis: 1/8 in. dia. by 9/32 in. lg.	400-002
	1	1	1	1	HOLDDOWN, Dashpot arm	4600142-10
	1	1	1	1	SCREW, Machine: pan head, Phillips drive, 6-32 by 3/16 in. lg.	471-066
	1	1	1	1	WASHER, Lock: external tooth, No.6	502-014
	1	1	1	1	DASHPOT	4130157-20
	1	1	1	1	STOP, Sashpot arm	4220223-10
	1	1	1	1	SCREW, Machine: pan head, Phillips drive, 6-32 by 3/16 in. lg.	471-066
	1	1	1	1	WASHER, Lock: external tooth, No.6	502-014
	1	1	1	1	ARM ASSEMBLY, Dashpot	4030234-10
	1	1	1	1	SCREW, Shoulder	474-315
	1	1	1	1	PLATE ASSEMBLY, Damper mounting	4040852-10
	4	4	4	4	SCREW, Machine: pan head, Phillips drive, 6-32 by 3/8 in. lg.	471-069
4	4	4	4	WASHER, Flat: No.6	501-009	
4	4	4	4	WASHER, Lock: external tooth, No.6	502-014	
1	1	1	1	ARM ASSEMBLY, Takeup tension	4030216-10	
1	1	1	1	TOP, Takeup tension arm	4250180-10	
1	1	1	1	SCREW, Machine: flat head, socket drive, 4-40 by 3/8 in. lg.	471-490	
1	1	1	1	ARM SUBASSEMBLY, Takeup tension	4040774-10	
1	1	1	1	SCREW, Set: headless, socket drive, 6-32 by 3/8 in. lg.	477-347	
1	1	1	1	GUIDE, Tape	4210184-10	
1	1	1	1	END, Takeup tension arm	4330196-10	
1	1	1	1	SCREW, Machine: pan head, Phillips drive, 4-40 by 5/8 in. lg.	471-065	
1	1	1	1	WASHER, Lock: external tooth, No.4	502-013	
1	1	1	1	SPRING, Takeup tension arm	4270228-10	
1	1	1	1	COVER, Slot: takeup tension arm	4290523-10	
1	1	1	1	PIN, Roll: 3/32 in. dia. by 5/8 in. lg.	406-002	
1	1	1	1	SCREW, Nylon: fillister head, Phillips drive, 4-40 by 3/4 in. lg.	471-836	
1	1	1	1	RING, Retaining: grip, Truarc 5555-31-S	430-117	
1	1	1	1	RING, Retaining: external, flat, Truarc 5100-31-S-ZD	430-007	
1	1	1	1	WASHER, Shim: 15/32 in. OD by 21/64 in. ID by 0.005 in. thk.	501-053	

TAPE TRANSPORT - 1" TAPE (CONTINUED)

Ref. Sym.	4020244				DESCRIPTION	Ampex Part Number
	-09	-10	-11	-12		
K509	1	1	1	1	SHAFT, Takeup tension	4210273-10
	1	1	1	1	SCREW, Set: headless, socket drive, 10-32 by 1/4 in. lg.	477-118
	1	1	1	1	SPRING, Stop	4270227-10
	1	1	1	1	PIN, Roll: 3/32 in. dia. by 1 in. lg.	406-012
	1	1	1	1	HOUSING ASSEMBLY, Takeup arm	4030215-10
	2	2	2	2	BEARING, Bronze	423-019
	1	1	1	1	HOUSING	4290522-10
	2	2	2	2	SCREW, Machine: flat head, Phillips drive, 4-40 by 3/8 in. lg.	471-328
	1	1	1	1	ARM ASSEMBLY, Tape lifter	4040713-10
	2	2	2	2	PAD	4130150-10
	1	1	1	1	BEARING, Bronze	423-083
	1	1	1	1	ARM	4230199-10
	1	1	1	1	SCREW, Shoulder	474-313
	1	1	1	1	SPRING, Solenoid pressure: tape lifter	4270231-10
	1	1	1	1	SPRING, Solenoid return: tape lifter	4270176-10
	1	1	1	1	NUT, Hex: self locking, 10-32	493-008
	1	1	1	1	SOLENOID ASSEMBLY	4030202-10
	1	1	1	1	SOLENOID	4590106-10
	1	1	1	1	BOLT, Eye	4400604-10
	1	1	1	1	PIN, Clevis: 1/8 in. dia. by 17/32 in. lg.	400-009
	1	1	1	1	PIN, Cotter: 1/16 in. dia. by 1/2 in. lg.	401-005
	1	1	1	1	WASHER, Felt: 1/2 in. OD by 1/4 in. ID by 1/4 in. thk.	503-015
	1	1	1	1	STOP, Solenoid	4220139-20
	2	2	2	2	SCREW, Machine: pan head, Phillips drive, 8-32 by 1/4 in. lg.	471-076
	2	2	2	2	WASHER, Lock: external tooth, No.8	502-068
	2	2	2	2	CONNECTOR, Solderless: disconnect splice	171-008
	2	2	2	2	SCREW, Machine: pan head, Phillips drive, 10-24 by 3/8 in. lg.	472-415
	2	2	2	2	WASHER, Flat: No.10	501-011
	2	2	2	2	WASHER, Lock: external tooth, No.10	502-016
	1	1	1	1	ESCUTCHEON, Reel: right	4110245-10
	1	1	1	1	ESCUTCHEON, Reel: left	4110245-20
	8	8	8	8	SCREW, Reel escutcheon	4400611-10
	1	1	1	1	RESISTOR BOX ASSEMBLY, Tension control	Not available
	1	1	1	1	COVER, Resistor box	4290506-10
	4	4	4	4	SCREW, Self-tapping: pan head, Phillips drive, #6 by 1/4 in. lg.	476-011
	R515	1	1	1	RESISTOR, Fixed: wirewound, tapped, 14 ohms	4510420-10
	R516	1	1	1	RESISTOR, Fixed: wirewound, tapped, 22.5 ohms	4510421-10
	R517	1	1	1	RESISTOR, Fixed: wirewound, tapped, 49 ohms	4510422-10
	3	3	3	3	STUD, Resistor mounting	4210283-10
	9	9	9	9	NUT, Kep: 8-32	496-001
6	6	6	6	WASHER, Insulating	503-007	
6	6	6	6	WASHER, Centering	506-003	
R518	1	1	1	RESISTOR, Fixed: composition, 330 ohms, ±10%, 1/2 W, RC20GF331K	041-042	
1	1	1	1	TIEPOINT, Solder lug: 3 terminals, Permonite 8020-3	180-240	
J510	1	1	1	CONNECTOR, Receptacle: male, 4 contact, Jones P-304-AB	147-036	
2	2	2	2	SCREW, Sem: pan head, slot drive, 6-32 by 5/16 in. lg.	475-066	
2	2	2	2	NUT, Kep: 6-32	496-005	
J514	1	1	1	CONNECTOR, Plug: female, 15 contact, Electric Regulator 300.105-21	144-297	
13	13	13	13	CONNECTOR, Solderless: Electric Regulator 71.25-2-2	169-572	
1	1	1	1	GROMMET, Elastic: MS-35489-8	260-020	
1	1	1	1	BRACKET, Resistor box	4260327-10	
4	4	4	4	SCREW, Machine: pan head, Phillips drive, 10-24 by 3/8 in. lg.	472-415	
4	4	4	4	WASHER, Lock: external tooth, No.10	502-016	
1	1	1	1	TENSION CONTROL ASSEMBLY	4040817-10	
1	1	1	1	POST, Sensing	4210278-10	
1	1	1	1	PLUG, Sensing post	4100155-10	
1	1	1	1	SCREW, Machine: pan head, Phillips drive, 6-32 by 5/16 in. lg.	471-068	
1	1	1	1	ARM, Tension control	4230227-10	
1	1	1	1	SCREW, Machine: pan head, Phillips drive, 6-32 by 5/16 in. lg.	471-068	
2	2	2	2	STOP, Tension arm	4220221-10	
2	2	2	2	SCREW, Machine: pan head, Phillips drive, 4-40 by 3/16 in. lg.	471-063	
P514	1	1	1	SWITCH, Tension control	4620178-10	
1	1	1	1	YOKE, Actuator	4230210-10	
1	1	1	1	SLIDE, Actuator	4210280-10	
4	4	4	4	SCREW, Machine: pan head, Phillips drive, 6-32 by 5/16 in. lg.	471-068	
1	1	1	1	SPRING, Return	4270234-10	
1	1	1	1	DASHPOT, Tension control	4130157-10	
1	1	1	1	BRACKET, Dashpot mounting	4260363-10	

TAPE TRANSPORT - 1" TAPE (CONTINUED)

Ref. Sym.	4020244				DESCRIPTION	Ampex Part Number
	-09	-10	-11	-12		
	2	2	2	2	SCREW, Machine: pan head, Phillips drive, 6-32 by 5/16 in. lg.	471-068
	1	1	1	1	TIMING BLOCK ASSEMBLY	4040821-10
	1	1	1	1	SPRING, Timing adjustment	4270235-10
	1	1	1	1	COUNTER BALANCE	4220220-10
	1	1	1	1	NUT, Hex: 4-40	492-008
	1	1	1	1	SCREW, Machine: cap head, socket drive, 4-40 by 5/8 in. lg.	470-013
	1	1	1	1	WASHER, Flat: No.4	501-008
	1	1	1	1	BRACKET, Dashpot actuating	4260362-10
	1	1	1	1	SCREW, Machine: pan head, Phillips drive, 4-40 by 3/8 in. lg.	471-062
	1	1	1	1	BLOCK, Adjusting	4220218-10
	1	1	1	1	SCREW, Set: headless, socket drive, 4-40 by 1/4 in. lg.	477-031
	1	1	1	1	SCREW, Machine: flat head, Phillips drive, 4-40 by 1/4 in. lg.	471-326
	1	1	1	1	RING, Retaining: grip, Truarc 555-31-S	430-117
	1	1	1	1	HUB, Tension arm	Not available
	2	2	2	2	SCREW, Set: headless, socket drive, 4-40 by 1/4 in. lg.	477-031
	1	1	1	1	WASHER, Shim: 0.010 in. thk.	4440113-20
	1	1	1	1	SHAFT, Tension control	Not available
	2	2	2	2	BEARING, Ball: Fafnir RM38KOD, FS30171	421-110
	2	2	2	2	RING, Retaining: internal, flat, Truarc N5000-86-S	430-027
	1	1	1	1	HOUSING, Tension control	Not available
	3	3	3	3	SCREW, Machine: pan head, Phillips drive, 10-24 by 3/4 in. lg.	472-418
	3	3	3	3	WASHER, Lock: external tooth, No.10	502-016
	1		1		ESCUTCHEON ASSEMBLY, Power and speed control	4040719-10
		1		1	ESCUTCHEON ASSEMBLY, Power and speed control	4040719-20
	2	2	2	2	PIN, Roll: 1/16 in. dia. by 3/8 in. lg.	406-022
	2	2	2	2	BALL, 5/32 in. dia.	420-998
	2	2	2	2	SPRING, Actuator	4270236-10
	2	2	2	2	ACTUATOR, Switch	4230202-10
	2	2	2	2	RING, Retaining: external, "E", Truarc 5144-9-MO	430-343
	2	2	2	2	ACTUATOR, Power and speed switch	4230203-10
	4	4	4	4	PIN, Actuator retainer	4210246-10
	1	1	1	1	PUSHBUTTON, Control: power	} must be ordered as a set
	1	1	1	1	PLATE, Pushbutton: power	
	1	1	1	1	PUSHBUTTON, Control: speed	} must be ordered as a set
	1		1		PLATE, Pushbutton: speed, 7 1/2 - 15 ips	
		1		1	PLATE, Pushbutton: speed, 15 - 30 ips	
	1	1	1	1	ESCUTCHEON, Power and speed control	Not available
	2	2	2	2	SCREW, Machine: flat head, socket drive, 6-32 by 1/4 in. lg.	471-776
	1	1	1	1	KNOB, Fast mode slider	4100173-10
	1	1	1	1	SCREW, Set: headless, socket drive, 8-32 by 1/8 in. lg.	477-348
	1	1	1	1	ESCUTCHEON ASSEMBLY, Pushbutton control	4040715-10
	4	4	4	4	SPRING, Pushbutton control	4270209-10
	1	1	1	1	SPRING, Pushbutton control (record)	4270209-20
	1	1	1	1	PUSHBUTTON, Control: stop	} must be ordered as a set
	1	1	1	1	PLATE, Pushbutton: stop	
	1	1	1	1	PUSHBUTTON, Control: fast	} must be ordered as a set
	1	1	1	1	PLATE, Pushbutton: fast	
	1	1	1	1	PUSHBUTTON, Control: play	} must be ordered as a set
	1	1	1	1	PLATE, Pushbutton: play	
	1	1	1	1	PUSHBUTTON, Control: edit	} must be ordered as a set
	1	1	1	1	PLATE, Pushbutton: edit	
	1	1	1	1	PUSHBUTTON, Control: record	} must be ordered as a set
	1	1	1	1	PLATE, Pushbutton: record	
	1	1	1	1	ESCUTCHEON, Pushbutton control	Not available
	2	2	2	2	SCREW, Machine: flat head, socket drive, 6-32 by 1/4 in. lg.	471-776
	1	1	1	1	FLANGE, Tape guide: upper	4220209-10
	1	1	1	1	SPACER, Tape guide	4220215-30
	1	1	1	1	FLANGE, Tape guide: lower	4220210-10
	2	2	2	2	SCREW, Tape guide	4400610-20
	1	1	1	1	BASE, Tape guide	4330222-10
	2	2	2	2	SCREW, Machine: cap head, socket drive, 6-32 by 5/8 in. lg.	470-072
	1		1		STROBOSTICKER, 60 cycle	4170128-10
			1	1	STROBOSTICKER, 50 cycle	4170128-20
	1	1	1	1	CONTROL BOX ANS SWITCH ASSEMBLY	4050331-10
S510	1	1	1	1	SWITCH ASSEMBLY, Fastwind	4040716-10
	10	10	10	10	SWITCH, Fastwind	4620171-10
	3	3	3	3	SPACER, Mounting: fastwind switch	4220195-10
	2	2	2	2	ROD, Tie: fastwind switch	4210242-10

TAPE TRANSPORT - 1" TAPE (CONTINUED)

Ref. Sym.	4020244				DESCRIPTION	Ampex Part Number
	-09	-10	-11	-12		
	4	4	4	4	NUT, Hex: 2-56	492-007
	4	4	4	4	WASHER, Lock: internal tooth, No.2	502-023
	1	1	1	1	SLIDE, Actuator: fastwind switch	4230200-10
	2	2	2	2	ROD, Tie: actuator, fastwind switch	4210243-10
	4	4	4	4	RING, Retainer: external, self-locking, Truarc 5105-9-S-PP	430-039
	2	2	2	2	SPRING, Fastwind switch	4270210-10
	1	1	1	1	BRACKET, Mounting	Not available
	2	2	2	2	SCREW, Machine: pan head, Phillips drive, 6-32 by 3/8 in. lg.	471-069
	2	2	2	2	NUT, Kep: 6-32	496-005
	1	1	1	1	BRACKET ASSEMBLY, Pushbutton control	4040714-10
S504	5	5	5	5	SWITCH, Lever: subminiature, SPDT, Cherry E-61-10A	120-394
S506	-	-	-	-	(Same as S504)	120-394
S507	-	-	-	-	(Same as S504)	120-394
S508	-	-	-	-	(Same as S504)	120-394
S509	-	-	-	-	(Same as S504)	120-394
	10	10	10	10	SCREW, Machine: pan head, Phillips drive, 2-56 by 1/2 in. lg.	472-456
	10	10	10	10	WASHER, Flat: No.2	501-007
	10	10	10	10	WASHER, Lock: split ring, No.2	502-001
	5	5	5	5	HOLDER, Pilot lamp	4630009-10
	5	5	5	5	SCREW, Machine: pan head, Phillips drive, 6-32 by 3/8 in. lg.	471-069
	5	5	5	5	WASHER, Lock: external tooth, No.6	502-014
	1	1	1	1	BRACKET, Mounting	Not available
	1	1	1	1	SWITCH ASSEMBLY, Power and speed control	4040724-10
	2	2	2	2	SPRING, Pushbutton	4270208-10
	3	3	3	3	HOLDER, Pilot lamp	150-045
	3	3	3	3	SCREW, Machine: pan head, Phillips drive, 6-32 by 1/4 in. lg.	471-067
	3	3	3	3	WASHER, Lock: external tooth, No.6	502-014
	1	1	1	1	INSULATOR, Switch	4170265-10
	2	2	2	2	SCREW, Self-tapping: hex washer head, slot drive, #6 by 1/4 in. lg.	476-998
S502	4	4	4	4	SWITCH, Lever: subminiature, SPDT, Cherry E-62-10H	120-398
	2	2	2	2	INSULATOR, Switch	4170263-10
	2	2	2	2	SCREW, Machine: pan head, Phillips drive, 2-56 by 1-3/8 in. lg.	472-898
	2	2	2	2	WASHER, Lock: internal tooth, No.2	502-023
	2	2	2	2	NUT, Hex: 2-56	492-007
S501	2	2	2	2	SWITCH, Lever: subminiature, SPDT, Cherry E-62-10H	120-398
	1	1	1	1	INSULATOR, Switch	4170263-10
	2	2	2	2	SCREW, Machine: pan head, Phillips drive, 2-56 by 7/8 in. lg.	472-459
	2	2	2	2	WASHER, Lock: internal tooth, No.2	502-023
	2	2	2	2	NUT, Hex: 2-56	492-007
	1	1	1	1	INSULATOR, Switch	4170264-10
	1	1	1	1	BRACKET, Mounting	Not available
P510	1	1	1	1	CONNECTOR, Plug: female, 4 contacts, Jones S-304-CCT-L	144-032
	2	2	2	2	CONNECTOR, Solderless: disconnect splice	171-008
	1	1	1	1	FANNING STRIP, Terminal: 8 position, Kulka 649-8	185-136
	1	1	1	1	CONTROL BOX ASSEMBLY	4050332-10
*	1	1	1	1	BIAS OSCILLATOR ASSEMBLY	4020237-01
	1	1	1	1	BRACKET ASSEMBLY, Oscillator	4050335-10
CR502	4	4	4	4	RECTIFIER, Silicon: 10 amp	580-035
CR503	-	-	-	-	(Same as CR502)	580-035
CR504	-	-	-	-	(Same as CR502)	580-035
CR505	-	-	-	-	(Same as CR502)	580-035
	2	2	2	2	BRACKET, Rectifier	4260238-10
	2	2	2	2	SCREW, Self-tapping: hex washer head, slot drive, #6 by 1/4 in. lg.	476-011
	1	1	1	1	FASTENER, Oscillator mounting	310-162
J501	1	1	1	1	CONNECTOR, Receptacle: female, 15 contacts, Cannon DA-15S	146-020
	2	2	2	2	SCREW, Self-tapping: hex washer head, slot drive, #4 by 3/16 in. lg.	476-185
	1	1	1	1	BRACKET, Oscillator	4260308-10
	1	1	1	1	ETCHED BOARD ASSEMBLY, Control box	4050333-10
C501	1	1	1	1	CAPACITOR, Electrolytic: 30 mfd, 250 vdcw, Sprague type DEE	031-468
C503	6	6	6	6	CAPACITOR, Mylar: 0.047 mfd, ±10%, 400 vdcw, El Menco 4 DP-3-473	035-764
C504	2	2	2	2	CAPACITOR, Mylar: 0.0047 mfd, ±10%, 600 vdcw, El Menco 6 DP-1-472	035-768
C505	-	-	-	-	(Same as C504)	035-768
C507	4	4	4	4	CAPACITOR, Mylar: 0.22 mfd, ±10%, 400 vdcw, El Menco 4 DP-5-224	035-766
C508	-	-	-	-	(Same as C503)	035-764
C510	2	2	2	2	CAPACITOR, Mylar: 0.1 mfd, ±10%, 400 vdcw, El Menco 4 DP-3-104	035-765
C511	1	1	1	1	CAPACITOR, Mylar: 0.5 mfd, ±10%, 400 vdcw, El Menco 4 DP-6-504	035-779

* See separate parts list later in this section.

TAPE TRANSPORT - 1" TAPE (CONTINUED)

Ref. Sym.	4020244				DESCRIPTION	Amper Part Number
	-09	-10	-11	-12		
C514	-	-	-	-	(Same as C503)	035-764
C515	-	-	-	-	(Same as C510)	035-765
C516	-	-	-	-	(Same as C507)	035-766
C517	-	-	-	-	(Same as C503)	035-764
C518	-	-	-	-	(Same as C503)	035-764
C519	-	-	-	-	(Same as C507)	035-766
C520	-	-	-	-	(Same as C507)	035-766
C521	-	-	-	-	(Same as C503)	035-764
CR501	3	3	3	3	DIODE, Crystal: diffused silicon, Type 1N2864	013-339
CR506	11	11	11	11	DIODE, Crystal: diffused silicon, Type 1N2863	580-027
CR507	-	-	-	-	(Same as CR506)	580-027
CR508	-	-	-	-	(Same as CR506)	580-027
CR509	-	-	-	-	(Same as CR506)	580-027
CR510	-	-	-	-	(Same as CR506)	580-027
CR511	-	-	-	-	(Same as CR506)	580-027
CR512	-	-	-	-	(Same as CR506)	580-027
CR513	-	-	-	-	(Same as CR506)	580-027
CR514	-	-	-	-	(Same as CR506)	580-027
CR515	-	-	-	-	(Same as CR506)	580-027
CR516	-	-	-	-	(Same as CR506)	580-027
CR517	-	-	-	-	(Same as CR501)	013-339
CR518	-	-	-	-	(Same as CR501)	013-339
R502	1	1	1	1	RESISTOR, Fixed: wirewound, 150 ohms, $\pm 5\%$, 10 W	047-660
R503	2	2	2	2	RESISTOR, Fixed: composition, 10 ohms, $\pm 10\%$, 1/2 W	041-032
R504	1	1	1	1	RESISTOR, Fixed: composition, 150 ohms, $\pm 10\%$, 1/2 W	041-241
R505	9	9	9	9	RESISTOR, Fixed: composition, 100 ohms, $\pm 10\%$, 1/2 W	041-038
R506	1	1	1	1	RESISTOR, Fixed: composition, 820 ohms, $\pm 10\%$, 1/2 W	041-047
R509	1	1	1	1	RESISTOR, Fixed: wirewound, 33 ohms, $\pm 10\%$, 2 W	047-654
R510	-	-	-	-	(Same as R505)	041-038
R511	2	2	2	2	RESISTOR, Fixed: wirewound, 2 ohms, $\pm 5\%$, 10 W	047-655
R512	-	-	-	-	(Same as R511)	047-655
R513	-	-	-	-	(Same as R505)	041-038
R519	2	2	2	2	RESISTOR, Fixed: wirewound, 15 ohms, $\pm 5\%$, 10 W	047-658
R520	4	4	4	4	RESISTOR, Fixed: wirewound, 5 ohms, $\pm 5\%$, 10 W	047-656
R521	2	2	2	2	RESISTOR, Fixed: wirewound, 40 ohms, $\pm 5\%$, 10 W	047-659
R522	-	-	-	-	(Same as R520)	047-656
R523	-	-	-	-	(Same as R520)	047-656
R524	-	-	-	-	(Same as R521)	047-659
R525	-	-	-	-	(Same as R520)	047-656
R526	-	-	-	-	(Same as R519)	047-658
R527	-	-	-	-	(Same as R505)	041-038
R528	-	-	-	-	(Same as R505)	041-038
R529	-	-	-	-	(Same as R505)	041-038
R530	1	1	1	1	RESISTOR, Fixed: wirewound, 10 ohms, $\pm 5\%$, 10 W	047-657
R531	-	-	-	-	(Same as R503)	041-032
R532	1	1	1	1	RESISTOR, Fixed: wirewound, 500 ohms, $\pm 5\%$, 10 W	047-815
R533	1	1	1	1	RESISTOR, Fixed: composition, 22 ohms, $\pm 10\%$, 1/2 W	041-033
R534	-	-	-	-	(Same as R505)	041-038
R535	-	-	-	-	(Same as R505)	041-038
R536	1	1	1	1	RESISTOR, Fixed: wirewound, 700 ohms, $\pm 5\%$, 10 W	047-661
R537	-	-	-	-	(Same as R505)	041-038
RV501	4	4	4	4	VARISTOR, Silicon carbide, 24 vdc	046-092
RV502	-	-	-	-	(Same as RV501)	046-092
RV503	-	-	-	-	(Same as RV501)	046-092
RV504	-	-	-	-	(Same as RV501)	046-092
C502	1	1	1	1	CAPACITOR, Electrolytic: 2000-750 mfd, 50 vdcw	4550145-20
C509	1	1	1	1	CAPACITOR, Electrolytic: 500-300-200-100 mfd	4550145-40
C512	1	1	1	1	CAPACITOR, Electrolytic: 1000 mfd, 100 vdcw	4550145-30
C513	1	1	1	1	CAPACITOR, Electrolytic: 500 mfd, 200 vdcw	4550145-10
F501	2	2	2	2	FUSE, Cartridge: 5 amp, 125v, slow blow, Littelfuse 313005 (115v operation)	070-020
F501	3	3	3	3	FUSE, Cartridge: 3 amp, 250v, fast blow, Littelfuse 312003 (230v operation)	070-001
F502	-	-	-	-	(Same as F501) (115v operation)	070-020
F502	-	-	-	-	(Same as F501) (230v operation)	070-001
F503	1	1	1	1	FUSE, Cartridge: 3 amp, 125v, slow blow, Littelfuse 313003 (115v operation)	070-002
F503	1	1	1	1	FUSE, Cartridge: 2 amp, 250v, fast blow, Littelfuse 312002 (230v operation)	070-016
F504	-	-	-	-	(Same as F501)	070-001
F505	1	1	1	1	FUSE, Cartridge: 1 amp, 125v, slow blow, Littelfuse 313001	070-004
J502	1	1	1	1	CONNECTOR, Receptacle: male, 3 contact, MS3102A10SL-3P	143-008

TAPE TRANSPORT - 1" TAPE (CONTINUED)

Ref. Sym.	4020244				DESCRIPTION	Ampex Part Number
	-09	-10	-11	-12		
J503	1	1	1	1	CONNECTOR, Receptacle: female, 6 contact, Jones S-306-AB	146-004
J504	1	1	1	1	CONNECTOR, Receptacle: male, 3 contact, Hubbell 7556G	147-052
J505	1	1	1	1	CONNECTOR, Receptacle: female, 2 contact, Despard 1320 & 1354	146-014
J506	4	4	4	4	CONNECTOR, Receptacle: female, 8 contact, Jones S-308-AB	146-003
J507	1	1	1	1	CONNECTOR, Receptacle: female, 12 contact, Jones S-312-AB	146-009
J508	1	1	1	1	CONNECTOR, Receptacle: female, 4 contact, Jones S-304-AB	146-005
J509	1	1	1	1	CONNECTOR, Receptacle: female: 10 contact, Jones S-310-AB	146-018
J511	-	-	-	-	(Same as J506)	146-003
J512	-	-	-	-	(Same as J506)	146-003
J513	-	-	-	-	(Same as J506)	146-003
K501	2	2	2	2	RELAY, 4 circuit	4590101-20
K502	-	-	-	-	(Same as K501)	4590101-20
K503	3	3	3	3	RELAY, 6 circuit	4590101-30
K504	2	2	2	2	RELAY, 2 circuit	4590101-10
K505	-	-	-	-	(Same as K503)	4590101-30
K506	-	-	-	-	(Same as K503)	4590101-30
K507	-	-	-	-	(Same as K504)	4590101-10
L501	1	1	1	1	CHOKER, Filter	4580174-10
P506	1	1	1	1	DUMMY PLUG ASSEMBLY, Capstan motor amplifier	4050138-20
P507	1	1	1	1	DUMMY PLUG ASSEMBLY, Remote control	4050371-01
R501	1	1	1	1	RESISTOR, Variable: 50K ohms	4520145-40
R507	1	1	1	1	RESISTOR, Fixed: composition, 470 ohms, ±10%, 2 W	041-199
R508	1	1	1	1	RESISTOR, Variable: 5000 ohms	4520150-10
R514	1	1	1	1	RESISTOR, Fixed: composition, 6800 ohms, ±10%, 1 W	041-156
S503	1	1	1	1	SWITCH, Line voltage adjust	4620177-10
T501	1	1	1	1	TRANSFORMER, Power	4580179-10
	5	5	5	5	HOLDER, Fuse: Littelfuse 342012	085-001
	1	1	1	1	KNOB	4100105-02
	1	1	1	1	SHIELD, Transformer	4290550-01
DS501	8	8	8	8	LAMP, Incandescent: miniature, bayonet, 24v, 0.07 amp, G. E. type 1829	060-011
DS502	-	-	-	-	(Same as DS501)	060-011
DS503	-	-	-	-	(Same as DS501)	060-011
DS504	-	-	-	-	(Same as DS501)	060-011
DS505	-	-	-	-	(Same as DS501)	060-011
DS506	-	-	-	-	(Same as DS501)	060-011
DS507	-	-	-	-	(Same as DS501)	060-011
DS508	-	-	-	-	(Same as DS501)	060-011

HEAD ASSEMBLY
ONE & TWO CHANNEL

		4020236					DESCRIPTION	Ampex Part Number
		-01	-02	-03	-04	-05		
	X						HEAD ASSEMBLY, One channel: fixed playback, 1/4-inch tape	4020236-01
		X					HEAD ASSEMBLY, One channel: adjustable playback, 1/4-inch tape	4020236-02
			X				HEAD ASSEMBLY, Two channel: fixed playback, 1/4-inch tape	4020236-03
				X			HEAD ASSEMBLY, Two channel: adjustable playback, 1/4-inch tape	4020236-04
**					X		HEAD ASSEMBLY, Two channel: fixed playback, 1/2-inch tape	4020236-05
	1	1	1	1	1	1	COVER ASSEMBLY, Head	4040749-10
	2	2	2	2	2	2	SCREW, Set: headless, socket drive, 10-32 by 5/16 in. lg.	477-048
	1		1			1	GATE ASSEMBLY, Head	4040816-10
		1		1			GATE ASSEMBLY, Head	4040816-30
	1	1	1	1	1	1	SHIELD COVER ASSEMBLY	4040813-10
	1		1			1	SHIELD COVER ASSEMBLY	4040815-10
		1		1			SHIELD COVER ASSEMBLY	4040824-10
	2	2	2	2	2	2	PLATE, Spring	4270155-10
	4	4	4	4	4	4	SCREW, Machine: pan head, Phillips drive, 4-40 by 3/16 in. lg.	471-009
	4	4	4	4	4	4	WASHER, Lock: split ring, No. 4	502-002
	2	2	2	2	2	2	PAD, Head gate: small	4130154-10
	1	1	1	1	1	1	PAD, Head gate: large	4130155-10
	1	1	1	1	1	1	PAD, Head gate: large	4130155-20
	1	1	1	1	1	1	GATE, Head	4290500-10
	2	2	2	2	2	2	SCREW, Set: headless, socket drive, 4-40 by 1/8 in. lg.	477-121
	2	2	2	2	2	2	PIN, Hinge: head gate	4210284-10
	2	2	2	2	2	2	LEVER ASSEMBLY, Gate closer	4040748-10
	2	2	2	2	2	2	SPRING, Gate closer	4270230-10
	2	2	2	2	2	2	PIN, Dowel: 1/16 in. dia. by 3/8 in. lg.	402-153
	2	2	2	2	2	2	SCREW, Set: headless, socket drive, 2-56 by 1/8 in. lg.	477-131
	2	2	2	2	2	2	BLOCK, Hinge: gate closer	4220213-10
	4	4	4	4	4	4	SCREW, Machine: cap head, socket drive, 4-40 by 5/16 in. lg.	470-009
	1	1	1	1	1	1	TAPE LIFTER ASSEMBLY	4040847-10
	1	1	1	1	1	1	TAPE LIFTER	4040846-10
	2	2	2	2	2	2	PIN, Dowel: 1/8 in. dia. by 7/8 in. lg.	402-019
	2	2	2	2	2	2	SCREW, Set: headless, socket drive, 4-40 by 1/8 in. lg.	477-121
	1	1	1	1	1	1	STOP, Tape lifter fork	4220174-10
	1	1	1	1	1	1	SPRING, Tape lifter hinge fork	4270232-10
	1	1	1	1	1	1	PAD, Tape lifter hinge	4130156-10
	1	1	1	1	1	1	SCREW, Machine: cap head, socket drive, 10-32 by 1/2 in. lg.	470-038
	1	1	1	1	1	1	NUT, Hex: 10-32	492-011
	1	1	1	1	1	1	FORK, Tape lifter hinge	4040747-10
	2	2	2	2	2	2	SCREW, Machine: cap head, socket drive, 8-32 by 5/8 in. lg.	470-030
	1	1	1	1	1	1	IDLER ASSEMBLY, Scrape flutter	4040809-10
	2	2	2	2	2	2	SCREW, Machine: cap head, socket drive, 6-32 by 3/8 in. lg.	470-018
	2	2	2	2	2	2	GUIDE, Tape	4210265-10
						2	GUIDE, Tape	4210265-20
	2	2	2	2	2	2	SCREW, Machine: cap head, socket drive, 10-32 by 1/2 in. lg.	470-038
	2	2	2	2	2	2	POST, Head cover mounting	4210248-10
	2	2	2	2	2	2	SCREW, Machine: cap head, socket drive, 8-32 by 1/2 in. lg.	470-999
	1	1	1	1	1	1	SHIELD CAN ASSEMBLY, Record	4040812-10
	1		1			1	SHIELD CAN ASSEMBLY, Reproduce: fixed	4040811-10
	4	2	4	2	4	4	NUT, Hex: 6-32, small pattern	492-034
	1		1			1	HEAD CAN ASSEMBLY, Reproduce: adjustable	4040823-10
	2		2			2	SCREW, Machine: cap head, socket drive, 6-32 by 3/8 in. lg.	470-018
	1					1	HEAD STACK, Reproduce: full track, 1/4-inch, adjustable	4040437-04
				1			HEAD STACK, Reproduce: two track, 1/4-inch, adjustable	4040437-03
	2		2			2	SPRING, Head	4270237-10
	2		2			2	SCREW, Machine: fillister head, slot drive, 4-40 by 3/4 in. lg.	471-484
	1		1			1	NUT, Hex: 4-40	492-008
	1		1			1	NUT, Hex: self-locking, 4-40	493-001
	1		1			1	WASHER, Lock: double split ring, No. 4	502-062
	1					1	HEAD STACK, Reproduce: full track, 1/4-inch, fixed	4040828-01
**			1			1	HEAD STACK, Reproduce: two track, 1/4-inch, fixed	4040830-01
	1	1				1	HEAD STACK, Reproduce: two track, 1/2-inch, fixed	4040832-01
			1	1			HEAD STACK, Record: full track, 1/4-inch	4040828-02
**					1		HEAD STACK, Record: two track, 1/4-inch	4040830-02
	1	1				1	HEAD STACK, Record: two track, 1/2-inch	4040832-02
			1	1			HEAD STACK, Erase: full track, 1/4-inch	4040829-01
**					1		HEAD STACK, Erase: two track, 1/4-inch	4040831-01
						1	HEAD STACK, Erase: two track, 1/2-inch	4040833-01

** Head stacks indicated are custom made.

HEAD ASSEMBLY
ONE & TWO CHANNEL (CONTINUED)

	4020236					DESCRIPTION	Ampex Part Number
	-01	-02	-03	-04	-05		
P110	3	2	3	2	3	SCREW, Machine: cap head, socket drive, 10-32 by 1/4 in. lg.	470-034
	1	1	2	2	2	HEAD CABLE ASSEMBLY, Reproduce	4050219-20
	1	1	1	1	1	CONNECTOR, Solderless: ring, Burndy YOC90	171-218
	1	1	1	1	1	CONNECTOR, Plug: female, 3 contact, MS3106B10SL-3S	140-008
	1	1	1	1	1	CLAMP, Cable: AN3057-4A	302-010
	a/r	a/r	a/r	a/r	a/r	CABLE	Not available
P109	1	1	1	1	1	CLAMP, Cable: Reproduce	4600137-10
	2	2	2	2	2	SCREW, Set: headless, socket drive, 10-32 by 3/8 in. lg.	477-049
	1	1	2	2	2	HEAD CABLE ASSEMBLY, Record	4050144-50
	1	1	1	1	1	CONNECTOR, Plug: female, 2 contact, MS3106A10SL-4S	140-009
	1	1	1	1	1	CLAMP, Cable: AN3057-4A	302-010
	a/r	a/r	a/r	a/r	a/r	CABLE	Not available
P107	1	1	2	2	2	HEAD CABLE ASSEMBLY, Erase	4050143-40
	1	1	1	1	1	CONNECTOR, Plug: female, 1 contact, MS3106B10S-2S	140-007
	1	1	1	1	1	CLAMP, Cable: AN3057-3A	302-009
	a/r	a/r	a/r	a/r	a/r	CABLE	Not available
	1	1	1	1	1	CLAMP, Cable: Record and erase	4600136-10
	4	4	4	4	4	SCREW, Set: headless, socket drive, 10-32 by 3/8 in. lg.	477-049
	1	1	1	1	1	BASE PLATE, Head	Not available

HEAD ASSEMBLY
THREE, FOUR, SIX & EIGHT CHANNEL

		4020236								DESCRIPTION	Ampex Part Number
		-06	-07	-08	-09	-10	-11	-12	-13		
	X									HEAD ASSEMBLY, Three channel: fixed playback, 1/2-inch tape	4020236-06
		X								HEAD ASSEMBLY, Three channel: adjustable playback, 1/2-inch tape	4020236-07
			X							HEAD ASSEMBLY, Four channel: fixed playback, 1/2-inch tape	4020236-08
				X						HEAD ASSEMBLY, Four channel: adjustable playback, 1/2-inch tape	4020236-09
**					X					HEAD ASSEMBLY, Three channel: fixed playback, 1-inch tape	4020236-10
**						X				HEAD ASSEMBLY, Four channel: fixed playback, 1-inch tape	4020236-11
**							X			HEAD ASSEMBLY, Six channel: fixed playback, 1-inch tape	4020236-12
**								X		HEAD ASSEMBLY, Eight channel: fixed playback, 1-inch tape	4020236-13
	1	1	1	1						COVER ASSEMBLY, Head	4040749-10
					1	1	1	1		COVER ASSEMBLY, Head	4040749-20
	2	2	2	2	2	2	2	2		SCREW, Set: headless, socket drive, 10-32 by 5/16 in. lg.	477-048
	1		1							GATE ASSEMBLY, Head	4040816-10
					1	1	1	1		GATE ASSEMBLY, Head	4040816-20
		1		1						GATE ASSEMBLY, Head	4040816-30
	1	1	1	1	1	1	1	1		SHIELD COVER ASSEMBLY	4040813-10
	1		1							SHIELD COVER ASSEMBLY	4040815-10
					1	1	1	1		SHIELD COVER ASSEMBLY	4040815-20
		1		1						SHIELD COVER ASSEMBLY	4040824-10
	2	2	2	2	2	2	2	2		PLATE, Spring	4270155-10
	4	4	4	4	4	4	4	4		SCREW, Machine: pan head, Phillips drive, 4-40 by 3/16 in. lg.	471-009
	4	4	4	4	4	4	4	4		WASHER, Lock: split ring, No. 4	502-002
	2	2	2	2	2	2	2	2		PAD, Head gate: small	4130154-10
	1	1	1	1	1	1	1	1		PAD, Head gate: large	4130155-10
	1	1	1	1	1	1	1	1		PAD, Head gate: large	4130155-20
	1	1	1	1	1	1	1	1		GATE, Head	4290500-10
	2	2	2	2	2	2	2	2		SCREW, Set: headless, socket drive, 4-40 by 1/8 in. lg.	477-121
	2	2	2	2	2	2	2	2		PIN, Hinge: head gate	4210284-10
	2	2	2	2	2	2	2	2		LEVER ASSEMBLY, Gate closer	4040748-10
	2	2	2	2	2	2	2	2		SPRING, Gate closer	4270230-10
	2	2	2	2	2	2	2	2		PIN, Dowel: 1/16 in. dia. by 3/8 in. lg.	402-153
	2	2	2	2	2	2	2	2		SCREW, Set: headless, socket drive, 2-56 by 1/8 in. lg.	477-131
	2	2	2	2	2	2	2	2		BLOCK, Hinge: gate closer	4220213-10
	4	4	4	4	4	4	4	4		SCREW, Machine: cap head, socket drive, 4-40 by 5/16 in. lg.	470-009
	1	1	1	1	1	1	1	1		TAPE LIFTER ASSEMBLY	4040847-10
	1	1	1	1	1	1	1	1		TAPE LIFTER	4040846-10
	2	2	2	2	2	2	2	2		PIN, Dowel: 1/8 in. dia. by 7/8 in. lg.	402-019
	2	2	2	2	2	2	2	2		SCREW, Set: headless, socket drive, 4-40 by 1/8 in. lg.	477-121
	1	1	1	1	1	1	1	1		STOP, Tape lifter fork	4220174-10
	1	1	1	1	1	1	1	1		SPRING, Tape lifter hinge fork	4270232-10
	1	1	1	1	1	1	1	1		PAD, Tape lifter hinge	4130156-10
	1	1	1	1	1	1	1	1		SCREW, Machine: cap head, socket drive, 10-32 by 1/2 in. lg.	470-038
	1	1	1	1	1	1	1	1		NUT, Hex: 10-32	492-011
	1	1	1	1	1	1	1	1		FORK, Tape lifter hinge	4040747-10
	2	2	2	2	2	2	2	2		SCREW, Machine: cap head, socket drive, 8-32 by 5/8 in. lg.	470-030
	1	1	1	1	1	1	1	1		IDLER ASSEMBLY, Scrape flutter	4040809-10
	2	2	2	2	2	2	2	2		SCREW, Machine: cap head, socket drive, 6-32 by 3/8 in. lg.	470-018
	2	2	2	2						GUIDE, Tape	4210265-20
					2	2	2	2		GUIDE, Tape	4210265-30
	2	2	2	2	2	2	2	2		SCREW, Machine: cap head, socket drive, 10-32 by 1/2 in. lg.	470-038
	2	2	2	2	2	2	2	2		POST, Head cover mounting	4210248-10
	2	2	2	2	2	2	2	2		SCREW, Machine: cap head, socket drive, 8-32 by 1/2 in. lg.	470-999
	1	1	1	1						SHIELD CAN ASSEMBLY, Record	4040812-10
					1	1	1	1		SHIELD CAN ASSEMBLY, Record	4040812-20
	1		1							SHIELD CAN ASSEMBLY, Reproduce: fixed	4040811-10
					1	1	1	1		SHIELD CAN ASSEMBLY, Reproduce: fixed	4040811-20
	4	2	4	2	4	4	4	4		NUT, Hex: 6-32, small pattern	492-034
	1			1						HEAD CAN ASSEMBLY, Reproduce: adjustable	4040822-10
	2			2						SCREW, Machine: cap head, socket drive, 6-32 by 3/8 in. lg.	470-018
	1									HEAD STACK, Reproduce: three track, 1/2-inch, adjustable	4040534-03
				1						HEAD STACK, Reproduce: four track, 1/2-inch, adjustable	4040558-03
		2		2						SPRING, Head	4270167-10
		2		2						SCREW, Machine: fillister head, slot drive, 4-40 by 5/8 in. lg.	471-481
		1		1						NUT, Hex: 4-40	492-008
		1		1						NUT, Hex: self-locking, 4-40	493-001
		1		1						WASHER, Lock: double split ring, No. 4	502-062
	1									HEAD STACK, Reproduce: three track, 1/2-inch, fixed	4040834-01
			1							HEAD STACK, Reproduce: four track, 1/2-inch, fixed	4040836-01

** Head stakes indicated are custom made.

HEAD ASSEMBLY
THREE, FOUR, SIX & EIGHT CHANNEL (CONTINUED)

		4020236							DESCRIPTION	Ampex Part Number		
		-06	-07	-08	-09	-10	-11	-12			-13	
**						1					HEAD STACK, Reproduce: three track, 1-inch, fixed	4040838-01
**							1				HEAD STACK, Reproduce: four track, 1-inch, fixed	4040840-01
**								1			HEAD STACK, Reproduce: six track, 1-inch, fixed	4040842-01
**									1		HEAD STACK, Reproduce: eight track, 1-inch, fixed	4040844-01
		1	1								HEAD STACK, Record: three track, 1/2-inch	4040834-02
				1	1						HEAD STACK, Record: four track, 1/2-inch	4040836-02
**						1					HEAD STACK, Record: three track, 1-inch	4040838-02
**							1				HEAD STACK, Record: four track, 1-inch	4040840-02
**								1			HEAD STACK, Record: six track, 1-inch	4040842-02
**									1		HEAD STACK, Record: eight track, 1-inch	4040844-02
		1	1								HEAD STACK, Erase: three track, 1/2-inch	4040835-01
				1	1						HEAD STACK, Erase: four track, 1/2-inch	4040837-01
**						1					HEAD STACK, Erase: three track, 1-inch	4040839-01
**							1				HEAD STACK, Erase: four track, 1-inch	4040841-01
**								1			HEAD STACK, Erase: six track, 1-inch	4040843-01
**									1		HEAD STACK, Erase: eight track, 1-inch	4040845-01
		3	2	3	2	3	3	3	3		SCREW, Machine: cap head, socket drive, 10-32 by 1/4 in. lg.	470-034
		3	3	4	4	3	4	6	8		HEAD CABLE ASSEMBLY, Reproduce	4050219-20
P110		1	1	1	1	1	1	1	1		CONNECTOR, Solderless: ring, Burndy YOC90	171-218
		1	1	1	1	1	1	1	1		CONNECTOR, Plug: female, 3 contact, MS3106B10SL-3S	140-008
		1	1	1	1	1	1	1	1		CLAMP, Cable: AN3057-4A	302-010
		a/r	a/r	a/r	a/r	a/r	a/r	a/r	a/r		CABLE	Not available
		1	1	1	1	1	1	1	1		CLAMP, Cable: Reproduce	4600137-10
		2	2	2	2	2	2	2	2		SCREW, Set: headless, socket drive, 10-32 by 3/8 in. lg.	477-049
P109		3	3	4	4	3	4	6	8		HEAD CABLE ASSEMBLY, Record	4050144-50
		1	1	1	1	1	1	1	1		CONNECTOR, Plug: female, 2 contact, MS3106A10SL-4S	140-009
		1	1	1	1	1	1	1	1		CLAMP, Cable: AN3057-4A	302-010
		a/r	a/r	a/r	a/r	a/r	a/r	a/r	a/r		CABLE	Not available
		3	3	4	4	3	4	6	8		HEAD CABLE ASSEMBLY, Erase	4050143-40
P107		1	1	1	1	1	1	1	1		CONNECTOR, Plug: female, 1 contact, MS3106B10S-2S	140-007
		1	1	1	1	1	1	1	1		CLAMP, Cable: AN3057-3A	302-009
		a/r	a/r	a/r	a/r	a/r	a/r	a/r	a/r		CABLE	Not available
		1	1	1	1	1	1	1	1		CLAMP, Cable: Record and erase	4600136-10
		4	4	4	4	4	4	4	4		SCREW, Set: headless, socket head, 10-32 by 3/8 in. lg.	477-049
		1	1	1	1	1	1	1	1		BASE PLATE, Head	Not available

** Head stacks indicated are custom made.

ELECTRONICS ASSEMBLY

Ref. Sym.	Qty.	DESCRIPTION	Ampex Part Number
	X	ELECTRONICS ASSEMBLY	4020233-01
*	2	OUTPUT AMPLIFIER ASSEMBLY	4020234-01
*	1	BIAS AMPLIFIER ASSEMBLY	4020235-01
	1	DUMMY PLUG ASSEMBLY, Meter panel	4050327-10
R186	1	RESISTOR, Fixed: composition, 3900 ohms, $\pm 5\%$, 1/4 W, RC07GF392J	041-511
R187	1	RESISTOR, Fixed: composition, 16K ohms, $\pm 5\%$, 1/4 W, RC07GF163J	041-749
P111	1	CONNECTOR, Plug: male, 10 contact, Jones P-310-CCT-L	145-020
	1	FRONT PANEL ASSEMBLY	Not available
	1	KNOB, Small: black, unskirted	4100105-02
	1	KNOB, Small: black, skirted	4100105-06
	1	KNOB, Small: black, red cap, unskirted	4100105-32
	1	KNOB, Small: black, red cap, skirted	4100105-36
	1	KNOB, Key tap: black	4100102-02
	2	KNOB, Lock: 1-in. dia, Raytheon KL701G	230-071
R185	1	RESISTOR, Fixed: composition, 6200 ohms, $\pm 5\%$, 1/4 W, RC07GF622J	041-538
M101	1	METER, VU	4140016-10
DS101	2	LAMP, Incandescent: miniature, bayonet, 7.5 v, 1 c.p., G.E. type 51	060-028
	1	HOUSING, Meter	4040720-10
S107	1	SWITCH, Output selector	4620173-10
S106	1	SWITCH, Meter	4620186-10
S105	1	SWITCH, Record selector	4620176-10
R103	1	RESISTOR, Variable: composition, 100 K ohms, $\pm 10\%$, 2 W	044-015
R138	1	RESISTOR, Variable: composition, 250 K ohms, $\pm 10\%$, 2 W	044-128
DS102	1	LAMP, Incandescent: red, clear lens, 6.3 v, Eldema BF03-RCB-2180	060-247
DS103	1	LAMP, Incandescent: amber, clear lens, 6.3 v, Eldema BF03-ACB-2180	060-248
J115	1	JACK, Phone: 2 conductor, open circuit, Switchcraft #11	148-015
	1	EQUALIZER PANEL ASSEMBLY	Not available
C106	1	CAPACITOR, Mica: 1270 pfd, $\pm 5\%$, 500 vdcw, Elmenco type DM20	034-964
C107	5	CAPACITOR, Trimmer: 15-130 pfd, 175 vdcw, Elmenco 302	038-002
C108	-	(Same as C107)	038-002
C109	1	CAPACITOR, Mica: 56 pfd, $\pm 5\%$, 500 vdcw, Elmenco DM15E560J0500WY4CR (Not Used for 30 ips CCIR)	034-697
C110	-	(Same as C107)	038-002
C111	-	(Same as C107)	038-002
C112	-	(Same as C107)	038-002
C128	5	CAPACITOR, Trimmer: 1400-3055 pfd, 175 vdcw, Elmenco 315	038-011
C132	-	(Same as C128)	038-011
C133	-	(Same as C128)	038-011
C134	1	CAPACITOR, Mica: 750 pfd, $\pm 5\%$, 300 vdcw, Elmenco DM15F751J	034-320
C135	-	(Same as C128)	038-011
C136	1	CAPACITOR, Mica: 350 pfd, $\pm 10\%$, 500 vdcw, Cornell-Dubilier 5A5T35	034-169
C137	-	(Same as C128)	038-011
C138	1	CAPACITOR, Mylar: 0.0039 mfd, $\pm 10\%$, 600 vdcw, Elmenco 6DP-1-392	035-767
C139	1	CAPACITOR, Trimmer: 450-1390 pfd, 350 vdcw, Elmenco 308	038-014
C140	3	CAPACITOR, Trimmer, 275-970 pfd, 175 vdcw, Elmenco 306	038-003
C141	-	(Same as C140)	038-003
C144	-	(Same as C140)	038-003
C147	1	CAPACITOR, Mylar: 0.047 mfd, $\pm 10\%$, 100 vdcw, Elmenco 1DP-2-473	035-776
K103	2	RELAY, 24 vdc: 4P2T, Potter & Brumfield KHP17D13	020-244
K104	-	(Same as K103)	020-244
R111	5	RESISTOR, Variable: composition, 250 K ohms	4520145-30
R112	3	RESISTOR, Fixed: film, 475 K ohms, $\pm 10\%$, 1/2 W, IRC type CEC-TO	048-139
R113	-	(Same as R112)	048-139
R114	-	(Same as R112)	048-139
R121	-	(Same as R111)	4520145-30
R122	1	RESISTOR, Variable: composition, 25 K ohms	4520145-20
R124	-	(Same as R111)	4520145-30
R127	1	RESISTOR, Variable: composition, 500 ohms	4520145-10
R154	-	(Same as R111)	4520145-30
R155	-	(Same as R111)	4520145-30
R156	2	RESISTOR, Fixed: composition, 10K ohms, $\pm 10\%$, 1/2 W, RC20GF104K	041-060
R157	-	(Same as R156)	041-060
R164	1	RESISTOR, Fixed: composition, 100 ohms, $\pm 10\%$, 1/2 W, RC20GF101K	041-038
S101	1	SWITCH, Equalization: 15 ips	4620174-10
S102	1	SWITCH, Equalization: $7\frac{1}{2}/30$ ips	4620175-10
S103	2	SWITCH, Equalization: low end	4620172-10
S104	-	(Same as S103)	4620172-10
	1	ETCHED BOARD ASSEMBLY, Preamplifier	4050321-10
C103	4	CAPACITOR, Mylar: 0.1 mfd, $\pm 10\%$, 400 vdcw, Elmenco 4DP-3-104	035-765

* See separate parts list later in this section.

ELECTRONICS ASSEMBLY (CONTINUED)

Ref. Svm.	Qty.	DESCRIPTION	Ampex Part Number
C104	2	CAPACITOR, Electrolytic: 100 mfd, +75%-10%, 3 vdcw, Sprague 40D107G003DC4	031-619
C105	1	CAPACITOR, Mica: 680 pfd, ±5%, 1000 vdcw, Elmenco VCM-20C681J	034-152
C114	1	CAPACITOR, Mylar: 0.22 mfd, ±10%, 400 vdcw, Elmenco 4DP-5-224	035-766
C115	2	CAPACITOR, Mylar: 0.022 mfd, ±10%, 400 vdcw, Elmenco 4DP-2-223	035-763
C119	-	(Same as C104)	031-619
C120	1	CAPACITOR, Mylar: 0.022 mfd, ±10%, 100 vdcw, Elmenco 1DP-1-223	035-777
C121	-	(Same as C103)	035-765
C122	-	(Same as C103)	035-765
C123	-	(Same as C115)	035-763
C124	1	CAPACITOR, Mylar: 0.018 mfd, ±5%, 400 vdcw, Elmenco 4DP-2-183 5%	035-866
C125	-	(Same as C103)	035-765
C126	1	CAPACITOR, Mylar: 0.047 mfd, ±10%, 400 vdcw, Elmenco 4DP-3-473	035-764
C129	1	CAPACITOR, Mylar: 0.0068 mfd, ±10%, 600 vdcw, Elmenco 6DP-1-682	035-769
C130	2	CAPACITOR, Mylar: 0.0047 mfd, ±10%, 600 vdcw, Elmenco 6DP-1-472	035-768
C131	-	(Same as C130)	035-768
C142	1	CAPACITOR, Mylar: 0.5 mfd, ±10%, 200 vdcw, Elmenco 2DP-5-504 (7½-15 ips only)	035-761
C145	1	CAPACITOR, Mylar: 0.27 mfd, ±10%, 400 vdcw, Elmenco 4DP-5-274 (15-30 ips only)	055-048
C145	1	CAPACITOR, Mylar: 0.0033 mfd, ±10%, 600 vdcw, Elmenco 6DP-1-332	035-515
CR101	2	DIODE, Crystal: diffused silicon, type 1N456	013-034
CR102	-	(Same as CR101)	013-034
L102	1	CHOKER, RF	4580177-10
R104	1	RESISTOR, Fixed: composition, 100 K ohms, ±10%, 1/4 W, RC07GF104K	041-626
R105	1	RESISTOR, Fixed: composition, 820 K ohms, ±5%, 1/2 W, RC20GF824J	041-555
R106	1	RESISTOR, Fixed: composition, 22 K ohms, ±10%, 1/2 W, RC20GF223K	041-064
R107	2	RESISTOR, Fixed: composition, 68 K ohms, ±10%, 1/2 W, RC20GF683K	041-070
R108	1	RESISTOR, Fixed: composition, 1000 ohms, ±10%, 1/2 W, RC20GF102K	041-048
R109	1	RESISTOR, Fixed: film, 100 K ohms, ±1%, 1/2 W, IRC type CEC-TO	048-414
R110	1	RESISTOR, Fixed: film, 383 K ohms, ±1%, 1/2 W, IRC type CEC-TO	048-519
R117	2	RESISTOR, Fixed: composition, 220 K ohms, ±10%, 1/2 W, RC20GF224K	041-076
R118	1	RESISTOR, Fixed: composition, 1800 ohms, ±10%, 1/2 W, RC07GF182K	049-335
R119	1	RESISTOR, Fixed: composition, 82 K ohms, ±10%, 1/2 W, RC20GF823K	041-071
R120	3	RESISTOR, Fixed: composition, 1 megohm, ±10%, 1/4 W, RC07GF105K	041-968
R130	1	RESISTOR, Fixed: wirewound, 47 K ohms, ±1%, 1/2 W, IRC series PH type 83	047-644
R131	1	RESISTOR, Fixed: composition, 620 ohms, ±5%, 1/4 W, RC07GF621J	041-505
R132	1	RESISTOR, Fixed: composition, 18 K ohms, ±10%, 1/2 W, RC32GF183K	041-161
R133	1	RESISTOR, Fixed: composition, 27 K ohms, ±10% 1/2 W, RC20GF273K	041-065
R134	-	(Same as R117)	041-076
R135	1	RESISTOR, Fixed: composition, 3.3 megohms, ±10%, 1/2 W, RC20GF335K	041-088
R136	1	RESISTOR, Fixed: composition, 1.5 megohms, ±10%, 1/2 W, RC20GF155K	041-085
R137	1	RESISTOR, Fixed: composition, 2.7 megohms, ±5%, 1/2 W, RC20GF275J	041-488
R139	1	RESISTOR, Fixed: composition, 5600 ohms, ±10%, 1 W, RC32GF562K	041-155
R140	1	RESISTOR, Fixed: composition, 33 K ohms, ±10%, 1/2 W, RC20GF333K	041-066
R141	1	RESISTOR, Fixed: wirewound, 27 K ohms, ±10%, 1/2 W, IRC series PH type 83	047-643
R142	-	(Same as R120)	041-968
R143	1	RESISTOR, Fixed: composition, 390 ohms, ±10%, 1/4 W, RC07GF391K	041-641
R144	1	RESISTOR, Fixed: wirewound, 15 K ohms, ±1%, 1/2 W, IRC series PH type 83	047-645
R145	-	(Same as R120)	041-968
R146	1	RESISTOR, Fixed: film, 178 K ohms, ±1%, 1/2 W, IRC type CEC-TO	048-518
R147	1	RESISTOR, Fixed: composition, 2.2 megohms, ±10%, 1/2 W, RC20GF225K	041-086
R148	1	RESISTOR, Fixed: film, 332 K ohms, ±1%, 1/2 W, IRC type CEC-TO	048-135
R149	1	RESISTOR, Fixed: composition, 680 ohms, ±10%, 1/4 W, RC07GF681K	049-334
R150	1	RESISTOR, Fixed: composition, 47 K ohms, ±5%, 1/4 W, RC07GF473J	041-411
R151	-	(Same as R107)	041-070
R152	1	RESISTOR, Fixed: composition, 27 K ohms, ±10%, 1 W, RC32GF273K	041-163
R153	1	RESISTOR, Fixed: composition, 22 K ohms, ±10%, 1 W, RC32GF223K	041-162
R160	1	RESISTOR, Fixed: composition, 12 K ohms, ±10%, 1/4 W, RC07GF123K	041-632
R161	1	RESISTOR, Fixed: film, 47.5 K ohms, ±1%, 1/2 W, IRC type CEC-TO	048-124
R162	1	RESISTOR, Fixed: film, 22.1 K ohms, ±1%, 1/2 W, IRC type CEC-TO	048-133
	1	TERMINAL BOARD ASSEMBLY, Record-Erase	4050323-10
C113	1	CAPACITOR, Mylar: 0.12 mfd, ±5%, 100 vdcw, Elmenco 1DP-3-124 5%	055-006
C116	1	CAPACITOR, Mica: 220 pfd, ±5%, 500 vdcw, Elmenco DM19F221J	034-687
C117	1	CAPACITOR, Mica: 1270 pfd, ±5%, 500 vdcw, Elmenco type DM20	034-964
L101	1	CHOKER, RF: 1 millihenry, Miller 9220-28	541-138
R115	1	RESISTOR, Fixed: film, 26.7 K ohms, ±1%, 1/2 W, IRC type CEC-TO	048-516
R116	1	RESISTOR, Fixed: composition, 150 K ohms, ±10%, 1/2 W, RC20GF154K	041-074
R123	1	RESISTOR, Fixed: composition, 1200 ohms, ±10%, 1/2 W, RC20GF122K	041-049
R125	1	RESISTOR, Fixed: composition, 47 K ohms, ±10%, 1/2 W, RC20GF473K	041-068
R178	1	RESISTOR, Fixed: composition, 1 megohm, ±10%, 1/2 W, RC20GF105K	041-031

ELECTRONICS ASSEMBLY (CONTINUED)

Ref. Svm.	Qty.	DESCRIPTION	Ampex Part Number
	1	ETCHED BOARD ASSEMBLY, Power supply	4050322-10
C143	1	CAPACITOR, Electrolytic: 20 mfd, +100%-15%, 50 vdcw, Sprague 30D206G050DC4	031-129
C146	5	CAPACITOR, Mylar: 0.022 mfd, ±10%, 400 vdcw, Elmenco 4 DP-2-223	035-763
C148	1	CAPACITOR, Mylar: 0.01 mfd, ±10%, 600 vdcw, Elmenco 6DP-2-103	035-770
C151	-	(Same as C146)	035-763
C152	-	(Same as C146)	035-763
C153	-	(Same as C146)	035-763
C154	-	(Same as C146)	035-763
CR105	4	DIODE, Crystal: diffused silicon, type 1N2864A	013-339
CR106	-	(Same as CR105)	013-339
CR107	-	(Same as CR105)	013-339
CR108	-	(Same as CR105)	013-339
R158	2	RESISTOR, Fixed: composition, 1200 ohms, ±10%, 2 W, RC42GF122K	041-203
R163	4	RESISTOR, Fixed: composition, 100 ohm, ±10%, 1/2 W, RC20GF101K	041-038
R165	-	(Same as R158)	041-203
R166	2	RESISTOR, Fixed: composition, 1200 ohms, ±10%, 1/2 W, RC20GF122K	041-147
R167	-	(Same as R167)	041-147
R168	1	RESISTOR, Fixed: composition, 100 ohms, ±10%, 1/2 W, RC07GF101K	049-333
R169	1	RESISTOR, Fixed: composition, 560 ohms, ±10%, 2 W, RC42GF561K	041-200
R170	-	(Same as R163)	041-038
R171	-	(Same as R163)	041-038
R172	1	RESISTOR, Fixed: composition, 2200 ohms, ±10%, 1 W, RC32GF222K	041-150
R173	-	(Same as R163)	041-038
R174	2	RESISTOR, Fixed: composition, 2200 ohms, ±10%, 1/2 W, RC20GF222K	041-052
R175	-	(Same as R174)	041-052
R176	1	RESISTOR, Fixed: composition, 470 ohms, ±10%, 1/2 W, RC20GF471K	041-044
	1	BACK PANEL ASSEMBLY	Not available
	1	OUTPUT TERMINAL BOARD ASSEMBLY	4050324-10
R179	1	RESISTOR, Fixed: composition, 560 ohms, ±10%, 1/2 W, RC20GF561K	041-045
R180	1	RESISTOR, Fixed: film, 5110 ohms, ±1%, 1/2 W, IRC type CEC-TO	048-156
R181	1	RESISTOR, Fixed: film, 4530 ohms, ±1%, 1/2 W, IRC type CEC-TO	048-514
R182	1	RESISTOR, Fixed: film, 2370 ohms, ±1%, 1/2 W, IRC type CEC-TO	048-776
R183	1	RESISTOR, Fixed: film, 8060 ohms, ±1%, 1/2 W, IRC type CEC-TO	048-515
R184	1	RESISTOR, Fixed: composition, 10 K ohms, ±10%, 1/2 W, RC20GF103K	041-060
F101	1	FUSE, Cartridge: 3/4 amp, 250 v, slow blow, Buss MDL 3/4 (115 v operation)	070-081
F101	1	FUSE, Cartridge: 3/8 amp, 250 v, slow blow, Buss MDL 3/8 (230 v operation)	070-992
J101	1	CONNECTOR, Receptacle: female, 3 contacts, Cannon XLR-3-13	146-007
J104	3	CONNECTOR, Receptacle: male, 3 contacts, MS3102A109SL-3P	143-008
J105	-	(Same as J104)	143-008
J107	1	CONNECTOR, Receptacle: male, 1 contact, MS3102A10S-2P	143-010
J109	1	CONNECTOR, Receptacle: male, 2 contacts, MS3102A10SL-4P	143-009
J110	-	(Same as J104)	143-008
J111	1	CONNECTOR, Receptacle: female, 10 contacts, Jones S-310-AB	146-018
J112	1	CONNECTOR, Receptacle: male, 8 contacts, Jones P-308-AB	147-006
J114	1	CONNECTOR, Receptacle: male, 3 contacts, Cannon XLR-3-14	147-004
K102	1	RELAY	4590101-30
R129	1	RESISTOR, Fixed: composition, 100 K ohms, ±10%, 1/2 W, RC20GF104K	041-072
TP101	2	CONNECTOR, Jack: tip, red, H. H. Smith 205RED	146-386
TP101	2	CONNECTOR, Jack: tip, black, H. H. Smith 205BLACK	146-385
TP102	-	(Same as TP101)	146-386
TP102	-	(Same as TP101)	146-385
	1	HOLDER, Fuse: Littelfuse 342012	085-001
C101	1	CAPACITOR, Electrolytic: 4 mfd, 450 vdcw, Sprague type DEE	031-009
C102	3	CAPACITOR, Electrolytic: 110-20-20-20 mfd, 450 vdcw	4550144-10
C118	-	(Same as C102)	4550144-10
C149	1	CAPACITOR, Electrolytic: 2000-1000 mfd, 15 vdcw	4550067-10
C150	-	(Same as C102)	4550144-10
CR103	2	DIODE, Crystal: diffused silicon, type 1N607	582-061
CR104	-	(Same as CR103)	582-061
J102	2	SOCKET, Tube: octal, Cinch 9905	150-023
J103	3	RECEPTACLE, Connector: female, 15 contacts, Cannon DA-15S	146-020
J106	-	(Same as J103)	146-020
J108	-	(Same as J102)	150-023
J113	-	(Same as J103)	146-020
K101	1	RELAY, 24 vdc: Automatic Electric PE-5011-B12	020-371
L103	1	CHOKER, Filament	4580174-10
L104	1	CHOKER, Filter	4580176-10
P102	1	DUMMY PLUG ASSEMBLY	4030034-10

ELECTRONICS ASSEMBLY (CONTINUED)

Ref. Sym.	Qty.	DESCRIPTION	Ampex Part Number
R101	1	RESISTOR, Fixed: composition, 22 K ohms, $\pm 10\%$, 1/2 W, RC20GF223K	041-064
R102	1	RESISTOR, Fixed: composition, 68 K ohms, $\pm 10\%$, 1 W, RC32GF683K	041-168
R126	1	RESISTOR, Fixed: composition, 56 K ohms, $\pm 10\%$, 1 W, RC32GF563K	041-167
R177	1	RESISTOR, Fixed: composition, 4700 ohms, $\pm 10\%$, 1/2 W, RC20GF472K	041-056
T101	1	TRANSFORMER, Input	4580178-10
T102	1	TRANSFORMER, Power	4580175-10
V101	8	TUBE, Electron: nuvistor, type 7895	012-204
V102	-	(Same as V101)	012-204
V103	-	(Same as V101)	012-204
V104	-	(Same as V101)	012-204
V105	-	(Same as V101)	012-204
V106	-	(Same as V101)	012-204
V107	-	(Same as V101)	012-204
V108	-	(Same as V101)	012-204
	8	SOCKET, Tube: nuvistor, 5 pin, Cinch 133-65-10-001	150-996

BIAS OSCILLATOR ASSEMBLY

Ref. Sym.	Qty.	DESCRIPTION	Ampex Part Number
	X	BIAS OSCILLATOR ASSEMBLY	4020237-01
	1	ETCHED BOARD ASSEMBLY, Bias oscillator	4050330-10
C701	6	CAPACITOR, Mylar: 0.01 mfd, $\pm 10\%$, 400 vdcw, Elmenco 4DP-1-103	035-762
C702	-	(Same as C701)	035-762
C704	-	(Same as C701)	035-762
C705	-	(Same as C701)	035-762
C706	-	(Same as C701)	035-762
C707	-	(Same as C701)	035-762
CR701	1	DIODE, Zener: silicon, type 1N985A	013-591
R701	2	RESISTOR, Fixed: composition, 15 K ohms, $\pm 10\%$, 1/2 W, RC20GF153K	041-062
R702	-	(Same as R701)	041-062
R703	4	RESISTOR, Fixed: composition, 10 K ohms, $\pm 10\%$, 1/2 W, RC20GF103K	041-060
R704	-	(Same as R703)	041-060
R705	2	RESISTOR, Fixed: composition, 47 K ohms, $\pm 5\%$, 1/4 W, RC07GF473J	041-411
R706	-	(Same as R705)	041-411
R707	1	RESISTOR, Fixed: composition, 47 K ohms, $\pm 10\%$, 1/2 W, RC20GF473K	041-068
R708	2	RESISTOR, Fixed: film, 4530 ohms, $\pm 1\%$, 1/2 W, IRC type CEC-TO	048-514
R709	-	(Same as R708)	048-514
R710	1	RESISTOR, Fixed: composition, 18 K ohms, $\pm 10\%$, 1/2 W, RC20GF183K	041-063
R711	-	(Same as R703)	041-060
R712	-	(Same as R703)	041-060
R713	2	RESISTOR, Fixed: composition, 1 megohm, $\pm 10\%$, 1/4 W, RC07GF105K	041-968
R714	-	(Same as R713)	041-968
C703	1	CAPACITOR, Mica: 150 pfd, $\pm 1\%$, 500 vdcw, Elmenco DM15F151F	034-220
P701	1	CONNECTOR, Receptacle: male, 15 contacts, Cannon DA-15P	147-998
T701	1	TRANSFORMER, Oscillator	4580115-10
V701	4	TUBE, Electron, nuvistor, type 7895	012-204
V702	-	(Same as V701)	012-204
V703	-	(Same as V701)	012-204
V704	-	(Same as V701)	012-204
	1	SOCKET, Tube: octal, Cinch 9905	150-023
	4	SOCKET, Tube: nuvistor, Cinch 133-65-10-001	150-996

BIAS AMPLIFIER ASSEMBLY

Ref. Sym.	Qty.	DESCRIPTION	Ampex Part Number
	X	BIAS AMPLIFIER ASSEMBLY	4020235-01
	1	ETCHED BOARD ASSEMBLY, Bias amplifier	4050329-10
C301	2	CAPACITOR, Mica: 220 pfd, $\pm 5\%$, 500 vdcw, Elmenco DM19F221J	034-687
C302	-	(Same as C301)	034-687
C303	1	CAPACITOR, Mylar: 0.1 mfd, $\pm 10\%$, 400 vdcw, Elmenco 4DP-3-104	035-765
C304	1	CAPACITOR, Mylar: 0.1 mfd, $\pm 10\%$, 400 bdcw, Elmenco 4DP-1-103	035-762
C305	1	CAPACITOR, Mica: 68 pfd, $\pm 5\%$, 1000 vdcw, Elmenco VDM20-680J	034-691
R301	2	RESISTOR, Fixed: composition, 470 K ohms, $\pm 10\%$, 1/2 W, RC20GF474K	041-080
R302	-	(Same as R301)	041-080
R303	2	RESISTOR, Fixed: composition, 10 K ohms, $\pm 10\%$, 1/4 W, RC07GF103K	041-633
R304	1	RESISTOR, Fixed: composition, 100 ohms, $\pm 10\%$, 1/2 W, RC20GF101K	041-038
R305	-	(Same as R303)	041-633
R306	1	RESISTOR, Fixed: composition, 68 K ohms, $\pm 10\%$, 1 W, RC32GF683K	041-168
C306	1	CAPACITOR, Trimmer: 1200-2525 pfd, 500 vdcw, Elmenco 315M	038-053
P301	1	CONNECTOR, Receptacle: male, 15 contacts, Cannon DA-15P	147-998
T301	1	TRANSFORMER, Bias	4580172-10
V301	2	TUBE, Electron: nuvistor, type 7587	012-205
V302	-	(Same as V301)	012-205
	1	SOCKET, Tube: octal, Cinch 9905	150-023
	2	SOCKET, Tube: nuvistor, Cinch 133-65-10-001	150-996
	2	CAP, Plate: tube, Alden Products 901SL-2BC	162-046

OUTPUT AMPLIFIER ASSEMBLY

Ref. Sym.	Qty.	DESCRIPTION	Ampex Part Number
	X	OUTPUT AMPLIFIER ASSEMBLY	4020234-01
	1	ETCHED BOARD ASSEMBLY, Output amplifier	4050328-10
C201	1	CAPACITOR, Mica: 1000 pfd, ±5%, 500 vdcw	034-153
C202	1	CAPACITOR, Mylar: 0.01 mfd, ±10%, 400 vdcw, Elmenco 4DP-1-103	035-762
C203	3	CAPACITOR, Mylar: 0.1 mfd, ±10%, 400 vdcw, Elmenco 4DP-3-104	035-765
C204	-	(Same as C203)	035-765
C205	1	CAPACITOR, Electrolytic: 25 mfd	031-620
C206	-	(Same as C203)	035-765
R201	1	RESISTOR, Fixed: composition, 100K ohms, ±10%, 1/2 W, RC20GF104K	041-072
R202	1	RESISTOR, Fixed: composition, 36 K ohms, ±5%, 1/2 W, RC20GF363J	041-456
R203	1	RESISTOR, Fixed: composition, 4700 ohms, ±10%, 1/2 W, RC20GF472K	041-056
R204	2	RESISTOR, Fixed: composition, 1200 ohms, ±5%, 1/2 W, RC20GF122J	041-405
R205	3	RESISTOR, Fixed: composition, 1 megohm, ±10%, 1/2 W, RC20GF105K	041-031
R206	-	(Same as R204)	041-405
R207	2	RESISTOR, Fixed: composition, 43 K ohms, ±5%, 1/2 W, RC20GF433J	041-019
R208	-	(Same as R205)	041-031
R209	-	(Same as R205)	041-031
R210	2	RESISTOR, Fixed: composition, 300 ohm, ±5%, 1/2 W, RC20GF301J	041-528
R211	-	(Same as R210)	041-528
R212	-	(Same as R207)	041-019
R213	1	RESISTOR, Fixed: composition, 120K ohms, ±10%, 1 W, RC32GF124K	041-171
P201	1	CONNECTOR, Receptacle: male, 15 contacts, Cannon DA-15P	147-998
T201	1	TRANSFORMER, Output	4580173-10
V201	2	TUBE, Electron: nuvistor, type 7895	012-204
V202	-	(Same as V201)	012-204
V203	2	TUBE, Electron: nuvistor, type 7587	012-205
V204	-	(Same as V203)	012-205
	4	SOCKET, Tube: nuvistor, Cinch 133-65-10-001	150-996
	2	CAP, Plate: tube, Alden Products 901SL-2BC	162-046

SYNCHRONIZING AMPLIFIER ASSEMBLY

Ref. Sym.	Qty.	DESCRIPTION	Ampex Part Number
	X	SYNCHRONIZING AMPLIFIER ASSEMBLY	4012107-01
C401	1	CAPACITOR, Mica: 100 pfd, $\pm 5\%$, 500 vdew, Elmenco DM15F101J	034-177
C402	1	CAPACITOR, Ceramic: 0.02 mfd, $\pm 10\%$, 500 vdew, Centralab DD-203	030-001
C403	1	CAPACITOR, Mylar: 0.0047 mfd, $\pm 10\%$, 600 vdew, Elmenco 6DP-1-472	035-768
C404	1	CAPACITOR, Mylar: 0.047 mfd, $\pm 10\%$, 400 vdew, Elmenco 4DP-3-473	035-764
P401	1	CAN, Plug-in	4290200-10
R401	2	RESISTOR, Fixed: composition, 68 K ohms, $\pm 10\%$, 1/2 W, RC20GF683K	041-070
R402	2	RESISTOR, Fixed: composition, 680 ohms, $\pm 10\%$, 1/4 W, RC07GF681K	049-334
R403	1	RESISTOR, Fixed: composition, 10 K ohms, $\pm 10\%$, 1/4 W, RC07GF103K	041-633
R404	1	RESISTOR, Fixed: composition, 1 megohm, $\pm 10\%$, 1/4 W, RC07GF105K	041-968
R405	-	(Same as R401)	041-070
R406	-	(Same as R402)	049-334
T401	1	TRANSFORMER, Input	4580100-10
V401	2	TUBE, Electron: nuvistor, type 7895	012-204
V402	-	(Same as V401)	012-204
	1	BRACKET	4260150-20
	2	SOCKET, Tube: nuvistor, Cinch 133-65-10-001	150-996

MICROPHONE PREAMPLIFIER ASSEMBLY

		Qty.		DESCRIPTION	Ampex Part Number
		-01	-04		
	X			MICROPHONE PREAMPLIFIER ASSEMBLY, 40 db	01-96440-01
	X			MICROPHONE PREAMPLIFIER ASSEMBLY, 60 db	01-96440-04
1	1			CAPACITOR, Mylar: 0.22 mfd, $\pm 10\%$, 200 vdcw, Cornell Dubilier WMF2P22E	035-939
1	1			CAPACITOR, Ceramic: 0.02 mfd, $+80\%-20\%$, 500 vdcw, Sprague 36C205	030-059
1	1			CAPACITOR, Mica: 27 pfd, $\pm 5\%$, 500 vdcw, Elmenco DM10C270J	034-987
1	1			CAPACITOR, Electrolytic: 25 mfd, 10 vdcw, IEI APD-023	031-140
1	1			RESISTOR, Fixed: composition, 1000 ohms, $\pm 10\%$, 1/2 W, RC20GF102K	041-048
1	1			RESISTOR, Fixed: composition, 75 K ohms, $\pm 5\%$, 1/2 W, RC20GF753J	041-253
1	1			RESISTOR, Fixed: composition, 180 K ohms, $\pm 10\%$, 1/2 W, RC20GF184K	041-075
1	1			RESISTOR, Fixed: composition, 270 K ohms, $\pm 10\%$, 1/2 W, RC20GF274K	041-077
1	1			RESISTOR, Fixed: composition, 51 K ohms, $\pm 5\%$, 1/2 W, RC20GF513J	041-021
1	1			RESISTOR, Fixed: composition, 18 K ohms, $\pm 10\%$, 1/2 W, RC20GF183K	041-063
1	1			RESISTOR, Fixed: composition, 220 K ohms, $\pm 5\%$, 1/2 W, RC20GF224J	041-027
1	1			RESISTOR, Fixed: composition, 47 ohms, $\pm 5\%$, 1 W, RC32 GF470J	041-941
1	1			RESISTOR, Fixed: composition, 3.3 megohms, $\pm 10\%$, 1/4 W, RC07GF335K	041-937
1	1			TRANSFORMER, Input	4580100-10
1	1			TUBE, Electron: nuvistor, type 7586	012-999
1	2			TUBE, Electron: nuvistor, type 6CW4	012-994
1	1			BRACKET	4260150-10
1	1			CAN, Plug-in	4290201-10
1	2			SOCKET, Tube: nuvistor, Cinch 133-65-10-001	150-996

CONSOLE ASSEMBLY

4010034				DESCRIPTION	Ampex Part Number
-01	-02	-03	-04		
X				CONSOLE ASSEMBLY, One channel	4010034-01
	X			CONSOLE ASSEMBLY, Two channel	4010034-02
		X		CONSOLE ASSEMBLY, Three channel	4010034-03
			X	CONSOLE ASSEMBLY, Four channel	4010034-04
1		1		PANEL ASSEMBLY, Backing	4040857-01
1		1		PANEL, Facing: blank	4290563-01
8	8	16	16	SCREW, Machine: oval head, Phillips drive, 12-24 by 3/4 in. lg.	472-889
3	3	3	3	SCREW, Machine: oval head, Phillips drive, 12-24 by 1-1/4 in. lg.	472-889
11	11	19	19	WASHER, Nylon: black, No.12	503-309
1	1			FINISHING PARTS, Console	4030237-01
		1	1	FINISHING PARTS, Console	4030237-02
1	1	1	1	PANEL ASSEMBLY, Front: hinged	4040869-01
1	1	1	1	CLAMP, Cable: "U" shaped, Dakota 2C1-100MX	300-038
1	1	1	1	SCREW, Machine: flat head, Phillips drive, 10-24 by 5/8 in. lg.	472-198
1	1	1	1	BRACKET ASSEMBLY, Cable clamp	4040890-01
2	2	2	2	SCREW, Machine: pan head, Phillips drive, 6-32 by 3/8 in. lg.	471-069
2	2	2	2	WASHER, Flat: No.6	501-009
2	2	2	2	WASHER, Lock: external tooth, No.6	502-014
2	2	2	2	STUD, Latch: Camloc 15S1-1-1AC	310-114
2	2	2	2	RETAINER, Stud: Camloc 15511-1AC	310-113
1	1	1	1	PANEL, Front	4040867-01
4	4	4	4	SCREW, Machine: pan head, Phillips drive, 6-32 by 3/8 in. lg.	471-069
4	4	4	4	WASHER, Flat: No.6	501-009
4	4	4	4	WASHER, Lock: external tooth, No.6	502-014
1	1	1	1	BAR, Frame support: hinge	4210289-01
2	2	2	2	SCREW, Machine: flat head, Phillips drive, 10-24 by 5/8 in. lg.	472-198
2	2	2	2	COVER ASSEMBLY, Slot: front	4040891-01
2	2	2	2	COVER, Slot	4290589-01
2	2	2	2	RETAINER, Transport frame	4230229-01
4	4	4	4	SCREW, Wood: round head, Phillips drive, #10 by 1-1/4 in. lg.	478-156
1	1	1	1	REAR PANEL ASSEMBLY, Transport	4040873-01
4	4	4	4	SCREW, Machine: truss head, Phillips drive, 10-24 by 3/8 in. lg.	472-979
2	2	2	2	SCREW, Machine: hex head, 10-24 by 3/8 in. lg.	472-963
2	2	2	2	WASHER, Flat: No.10	501-011
1	1	1	1	PANEL, Cover: rear	4290557-01
8	8	8	8	SCREW, Machine: truss head, Phillips drive 10-24 by 1 in. lg.	472-962
1	1			PANEL, Rear: electronics housing	4290561-01
		1	1	PANEL, Rear: electronics housing	4290560-01
6	6	6	6	SCREW, Machine: truss head, Phillips drive, 10-24 by 1-1/2 in. lg.	472-961
6	6	6	6	NUT, Speed: 10-24	497-159
2	2	2	2	COVER, Cable	4290559-01
2	2	2	2	CLAMP, Cable: nylon, 6 in. lg. Panduit type LSC-2	302-094
2	2	2	2	SCREW, Machine: pan head, Phillips drive, 10-24 by 1/2 in. lg.	472-123
2	2	2	2	WASHER, Flat: No.10	501-011
2	2	2	2	NUT, Hex: 10-24	492-043
2	2	2	2	SCREW, Machine: hex head, 1/4-20 by 1 in. lg. (SHIPPING RETAINING)	480-034
10	10	10	10	WASHER, Flat: 3/8 in. ID by 7/8 in. OD by 5/64 in. thk. (SHIPPING RETAINING)	501-573
1	1			CABINET ASSEMBLY, Console	4030235-01
		1	1	CABINET ASSEMBLY, Console	4030235-02
1	1	1	1	COVER, Rear: base	4290558-01
6	6	6	6	SCREW, Machine: truss head, Phillips drive, 10-24 by 1 in. lg.	472-962
1	1	1	1	FRAME ASSEMBLY, Transport	4030239-01
1	1	1	1	LOCK ASSEMBLY, Transport	4030236-01
1	1	1	1	PLATE, Lock: transport	4330232-01
1	1	1	1	UNION, Lock: transport	4220225-01
1	1	1	1	PIN, Roll: 3/32 in. dia. by 3/4 in. lg.	406-006
1	1	1	1	PIN, Roll: 1/16 in. dia. by 1/2 in. lg.	406-023
1	1	1	1	PLUNGER ASSEMBLY, Lock	4040866-01
1	1	1	1	SPRING, Lock: transport	4270239-01
1	1	1	1	BODY, Lock: transport	4210292-01
2	2	2	2	SCREW, Machine: pan head, Phillips drive, 10-24 by 1/2 in. lg.	472-123
2	2	2	2	WASHER, Flat: No.10	501-011
2	2	2	2	WASHER, Lock: external tooth, No.10	502-016
2	2	2	2	SHAFT, Transport frame	4210287-01
2	2	2	2	NUT, Hex: jam, 3/4-16	494-206
2	2	2	2	RECEPTACLE, Latch: Camloc 15R1-1AC	310-112
2	2	2	2	NUT, Hex: latch, 15/32-32: Camloc 15R10-1AC	310-115
2	2	2	2	WASHER, Lock: internal tooth, 1/2 in.	502-060

CONSOLE ASSEMBLY (CONTINUED)

4010034				DESCRIPTION	Ampex
-01	-02	-03	-04		Part Number
2	2	2	2	BRACKET, Latch	4260375-01
4	4	4	4	SCREW, Machine: pan head, Phillips drive, 6-32 by 3/8 in. lg.	471-069
4	4	4	4	WASHER, Flat: No.6	501-009
4	4	4	4	WASHER, Lock: external tooth, No.6	502-014
1	1	1	1	FRAME, Transport	4040865-01
2	2	2	2	BEARING, Flanged: Boston Gear FB-1216-8-DRY	422-035
8	8	8	8	SPACER, Frame: transport	4220226-01
2	2	2	2	STIFFNER, Housing support	4150293-01
1	1			HOUSING ASSEMBLY, Electronics	4030240-01
		1	1	HOUSING ASSEMBLY, Electronics	4030240-02
1	1	1	1	COVER, Housing	4290533-01
4	4	4	4	SCREW, Machine: truss head, Phillips drive, 10-24 by 1 in. lg.	472-962
1	1			SIDE PANEL, Electronics housing: left	4040871-01
		1	1	SIDE PANEL, Electronics housing: left	4040871-02
1	1			SIDE PANEL, Electronics housing: right	4040872-01
		1	1	SIDE PANEL, Electronics housing: right	4040872-02
4	4	4	4	SCREW, Machine: hex head, 1/4-20 by 3/4 in. lg.	472-933
12	12	12	12	WASHER, Flat: 0.281 in. ID	501-067
4	4	4	4	WASHER, Lock: split ring, 1/4 in.	502-006
1	1	1	1	CHANNEL, Crossbar: electronics housing	4150278-01
2	2	2	2	SCREW, Machine: pan head, Phillips drive, 10-24 by 3/8 in. lg.	472-415
2	2	2	2	WASHER, Flat: No.10	501-011
2	2	2	2	WASHER, Lock: external tooth, No.10	502-016
6	6	6	6	BRACKET, Angle: Tinnerman: C6039-1024-3	290-127
6	6	6	6	SCREW, Machine: flat head, Phillips drive, 10-24 by 3/8 in. lg.	472-195
1	1			CHANNEL, Support: electronics, right	4150286-01
1	1			CHANNEL, Support: electronics, left	4150286-02
		1	1	CHANNEL, Support: electronics, right	4150287-01
		1	1	CHANNEL, Support: electronics, left	4150287-02
6	6	10	10	SCREW, Machine: hex head, 1/4-20 by 3/4 in. lg.	472-933
6	6	10	10	WASHER, Flat: 0.281 in. ID	501-067
6	6	10	10	WASHER, Lock: split ring, 1/4 in.	502-006
1	1			SUPPORT, Electronics housing: left	4150292-01
		1	1	SUPPORT, Electronics housing: left	4150288-01
1	1			SUPPORT, Electronics housing: right	4150292-02
		1	1	SUPPORT, Electronics housing: right	4150288-02
4	4	4	4	SCREW, Machine: hex head, 5/16-18 by 3-3/4 in. lg.	470-389
4	4	4	4	WASHER, Flat: 3/8 in. ID by 7/8 in. OD by 5/64 in. thk.	501-573
4	4	4	4	WASHER, Lock: split ring, 5/16	502-352
1	1	1	1	BASE ASSEMBLY, Console	4030238-01
1	1	1	1	FRONT PANEL ASSEMBLY	4040863-01
2	2	2	2	SCREW, Machine: pan head, Phillips drive, 10-32 by 1-1/4 in. lg.	471-864
2	2	2	2	WASHER, Flat: No.10	501-011
2	2	2	2	WASHER, Lock: external tooth, No.10	502-016
1	1	1	1	SHELF, Front	4150279-01
4	4	4	4	SCREW, Machine: round head, Phillips drive, 1/4-20 by 1 in. lg.	472-964
4	4	4	4	WASHER, Flat: 0.281 in ID	501-067
1	1	1	1	SHELF, Rear	4150280-01
8	8	8	8	SCREW, Machine: round head, Phillips drive, 1/4-20 by 1 in. lg.	472-964
8	8	8	8	WASHER, Flat: 0.281 in. ID	501-067
2	2	2	2	BRACKET, Rear panel	4040864-01
4	4	4	4	SCREW, Wood: round head, Phillips drive, #8 by 1/2 in. lg.	478-026
4	4	4	4	WASHER, Flat: No.8	501-206
4	4	4	4	WASHER, Lock: external tooth, No.8	502-015
1	1	1	1	PANEL, Rear base	4150281-01
8	8	8	8	SCREW, Machine: round head, Phillips drive, 1/4-20 by 1-3/4 in. lg.	472-965
8	8	8	8	WASHER, Flat: 0.281 in. ID	501-067
2	2	2	2	CASTER, Front: with brake: Shepard Casters SN5	082-019
2	2	2	2	CASTER, Rear: Shepard Casters SN5	082-018
4	4	4	4	NUT, Hex: 3/8-16	492-056
1	1	1	1	SIDE PANEL, Base: right	4040870-01
1	1	1	1	SIDE PANEL, Base: left	4040870-02

A

PLAY HOLDBACK TENSION

TAPE WIDTH	TERMINAL (ALL SPEEDS)
1/4" NORMAL MOTOR *	68
1/4" WIDE TAPE MOTOR *	69
1/2"	68
1"	65

B

REEL IDLER START : HI

SPEEDS	TERMINAL FOR TAPE WIDTH		
	1/4"	1/2"	1"
7.5 - 15 IPS	71		
15 - 30 IPS	75		74

C

REEL IDLER START : LO

SPEEDS	TERMINAL FOR TAPE WIDTH		
	1/4"	1/2"	1"
7.5 - 15 IPS	69		
15 - 30 IPS	71		

D

EDIT BRAKING

TAPE WIDTH	TERMINAL (ALL SPEEDS)
1/4"	67
1/2" & 1"	67

E

PLAY TAKE-UP : RUN

TAPE WIDTH	TERMINAL AT SPEED	
	7.5 - 15	15 - 30
1/4" NORMAL MOTOR *		
1/4" WIDE TAPE MOTOR *	67	
1/2"	67	
1"		68

F

PLAY TAKE-UP : START

TAPE WIDTH	TERMINAL AT SPEED	
	7.5 - 15	15 - 30
1/4" NORMAL MOTOR *		
1/4" WIDE TAPE MOTOR *	70	
1/2"	70	
1"		74

* NORMAL MOTOR FOR 1/4" TAPE IS * 4590073 .

* MOTOR FOR 1/2" & 1" TAPE (* 4590084) MAY

BE USED WITH 1/4" TAPE WHEN SET TO TERMINAL SHOWN IN TABLES .

NOTE - IT MAY BE NECESSARY TO ATTACH LEADS TO DIFFERENT TERMINALS TO ACHIEVE CORRECT TORQUES ; SEE INSTRUCTIONS IN TEXT, SEC. 4.2 .

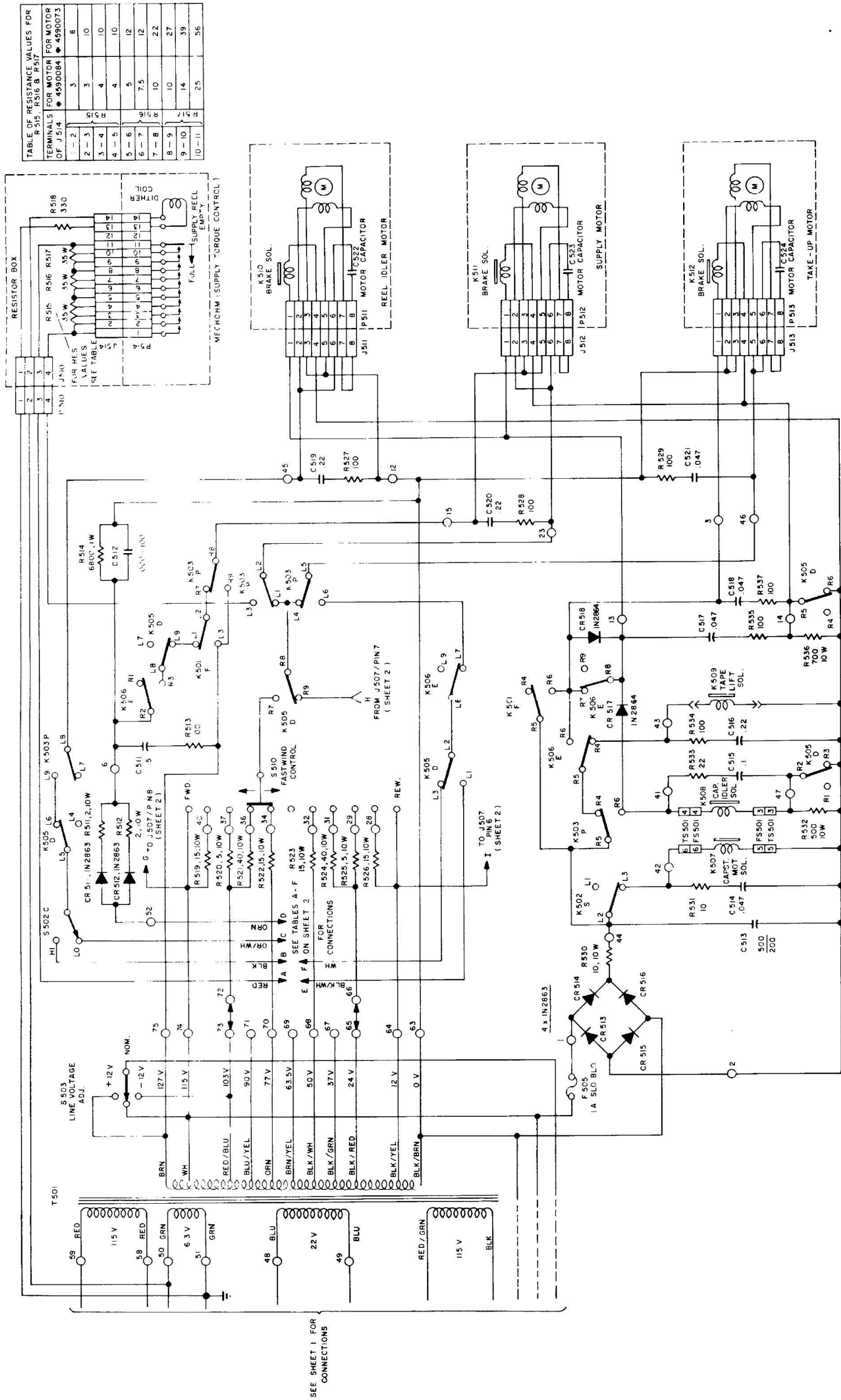

Fig. 7-2. Schematic Diagram—Transport, Motor Control

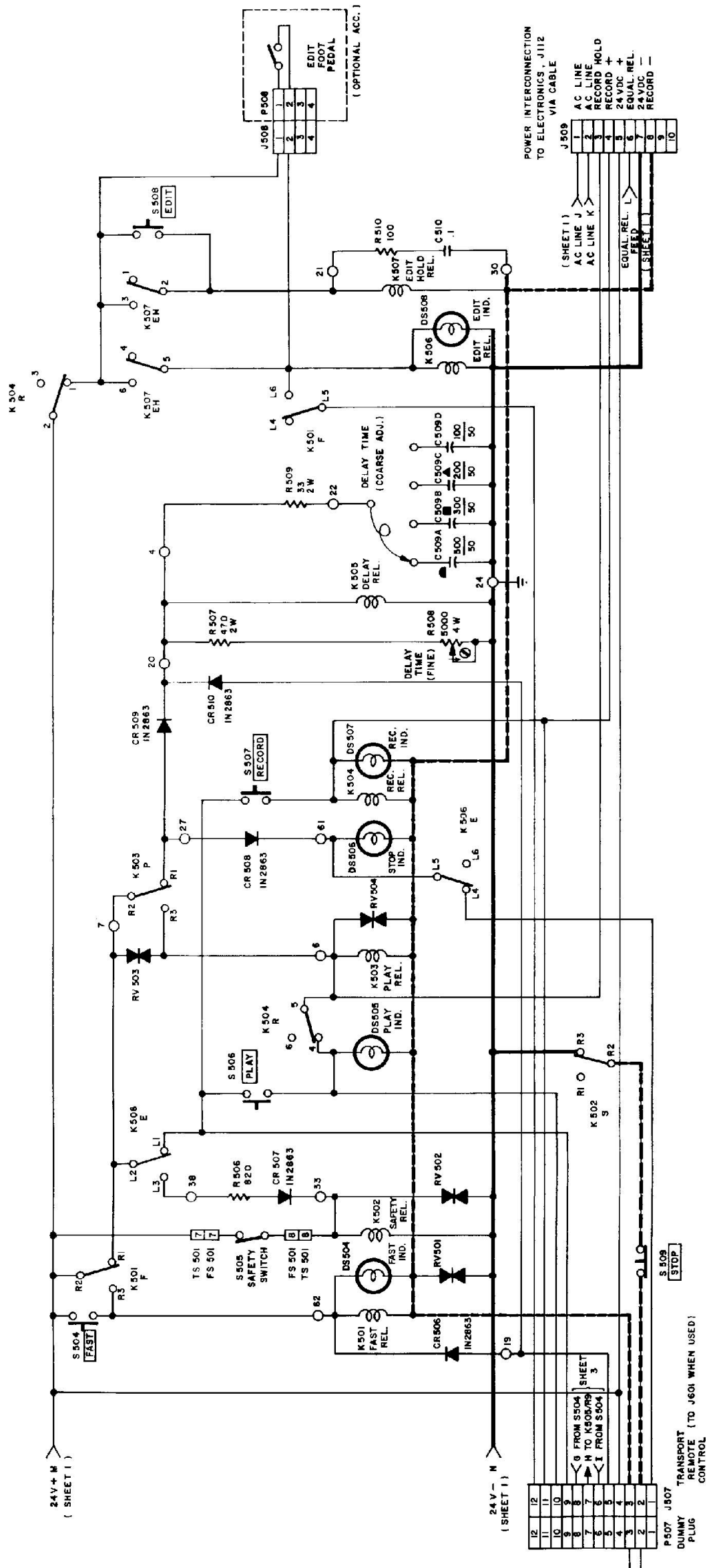
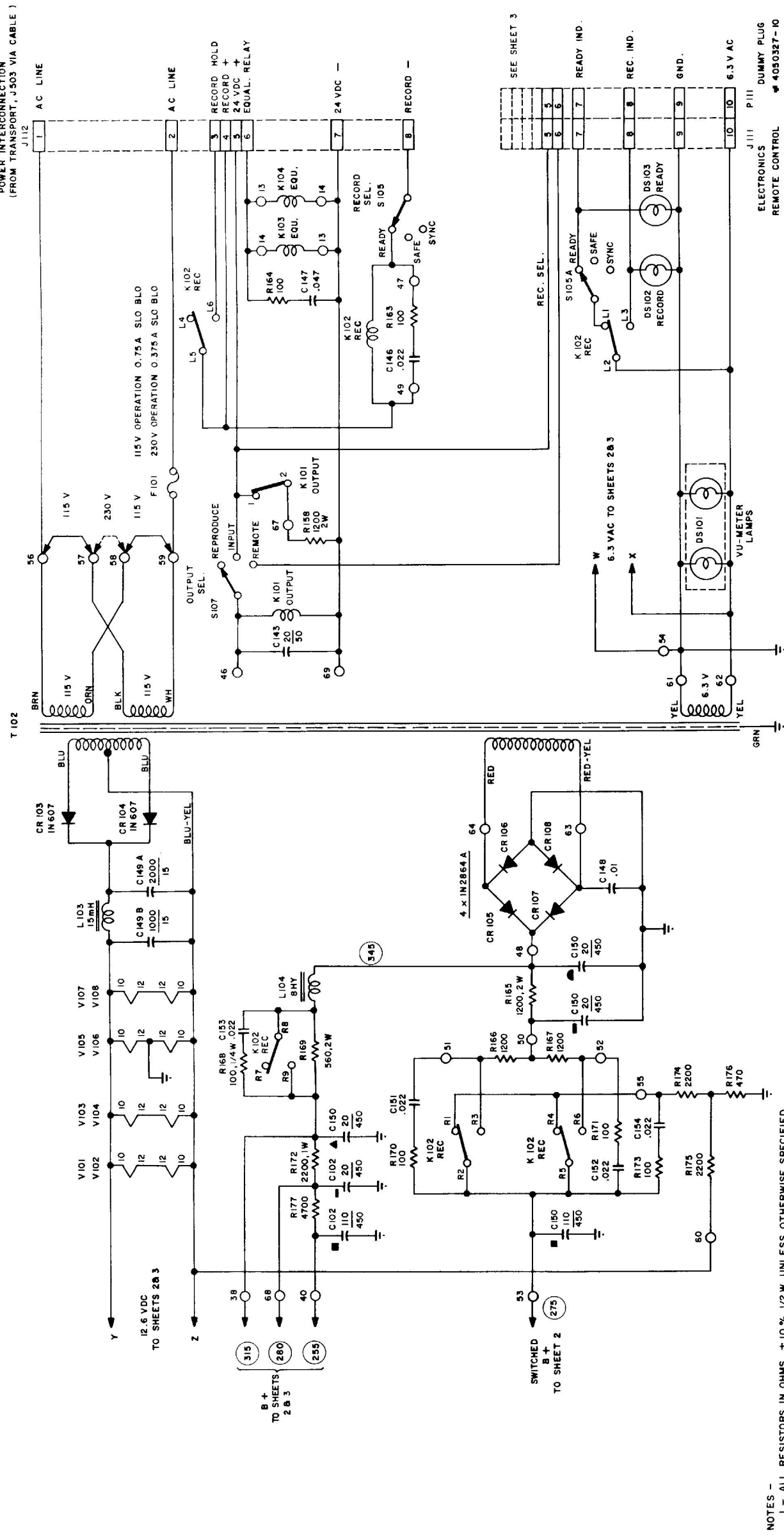

Fig. 7-3. Schematic Diagram—Transport, Logic Section

POWER INTERCONNECTION
(FROM TRANSPORT, J 503 VIA CABLE)
J 112



- NOTES -
- 1 - ALL RESISTORS IN OHMS, ± 10% 1/2 W UNLESS OTHERWISE SPECIFIED.
 - 2 - ALL CAPACITORS IN MFD, 400 VDC UNLESS OTHERWISE SPECIFIED.
 - 3 - SWITCHES ARE SHOWN AS THEY FUNCTION NOT AS THEY ARE CONSTRUCTED.
 - 4 - DC VOLTAGES MEASURED FROM POINT TO GROUND USING A VTVM HAVING 10 MEG OHM INPUT RESISTANCE.
 - 5 - SIGNAL VOLTAGES MEASURED WITH AC VTVM.
- CIRCUIT CONDITIONS -
- 1 - REPRODUCE & ERASE HEADS DISCONNECTED - 220 OHM RESISTOR CONNECTED ACROSS TERMINALS A & B OF J 109 IN PLACE OF RECORD HEAD.
 - 2 - BIAS OSCILLATOR INPUT DISCONNECTED.
 - 3 - 500 CPS INPUT.
 - 4 - REPRODUCE LEVEL CONTROL SET SO, THAT 0 DB AT TP 102 PRODUCES +8 DBM OUTPUT.
 - 5 - RECORD LEVEL CONTROL SET FULLY CLOCKWISE.
 - 6 - EQUALIZATION - 15 IPS NAB.
 - 7 - ELECTRONICS IN RECORD MODE.

Fig. 7-4. Schematic Diagram—Electronics, Power Supply

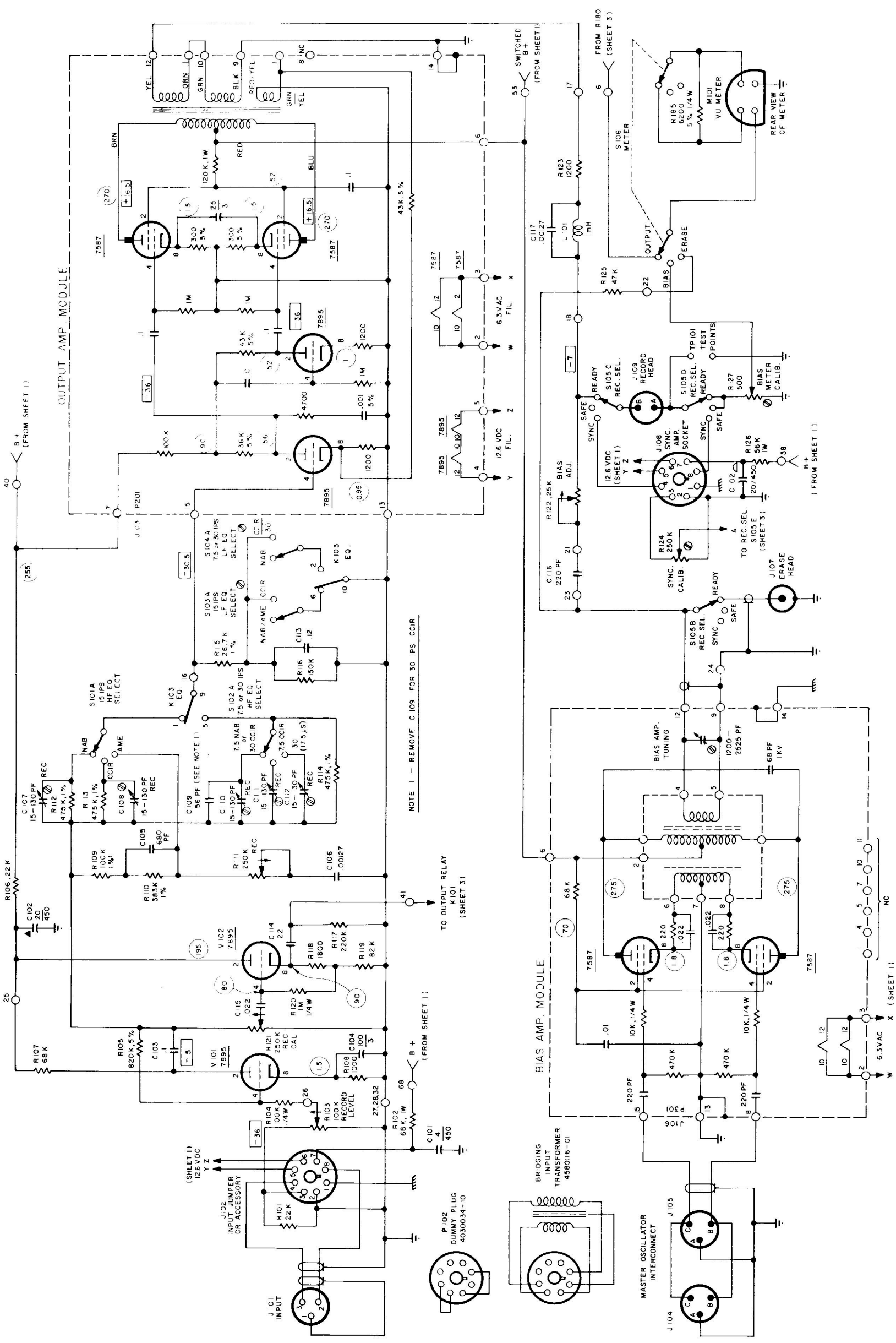

Fig. 7-5. Schematic Diagram - Electronics, Record Section

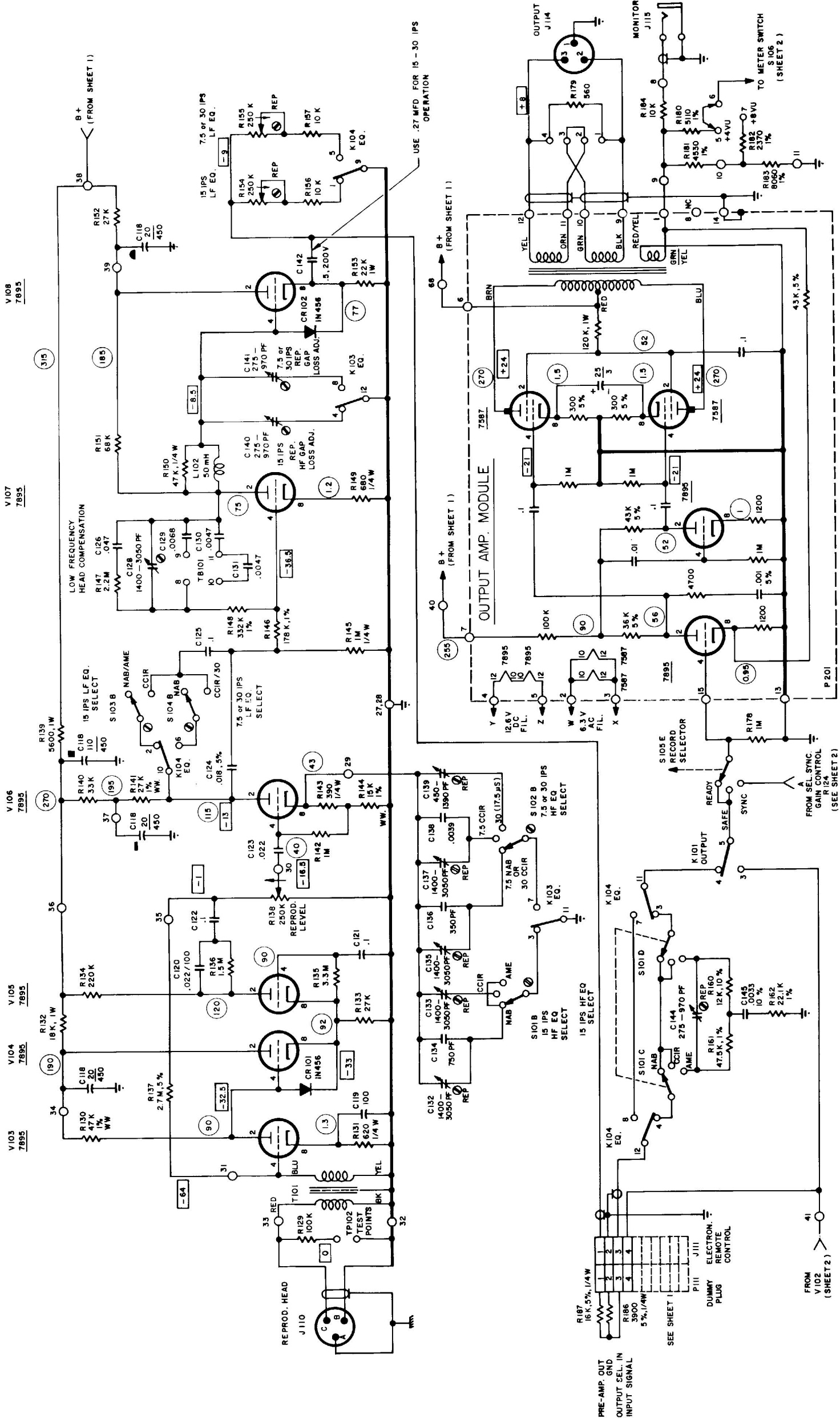

Fig. 7-6. Schematic Diagram—Electronics, Reproduce Section

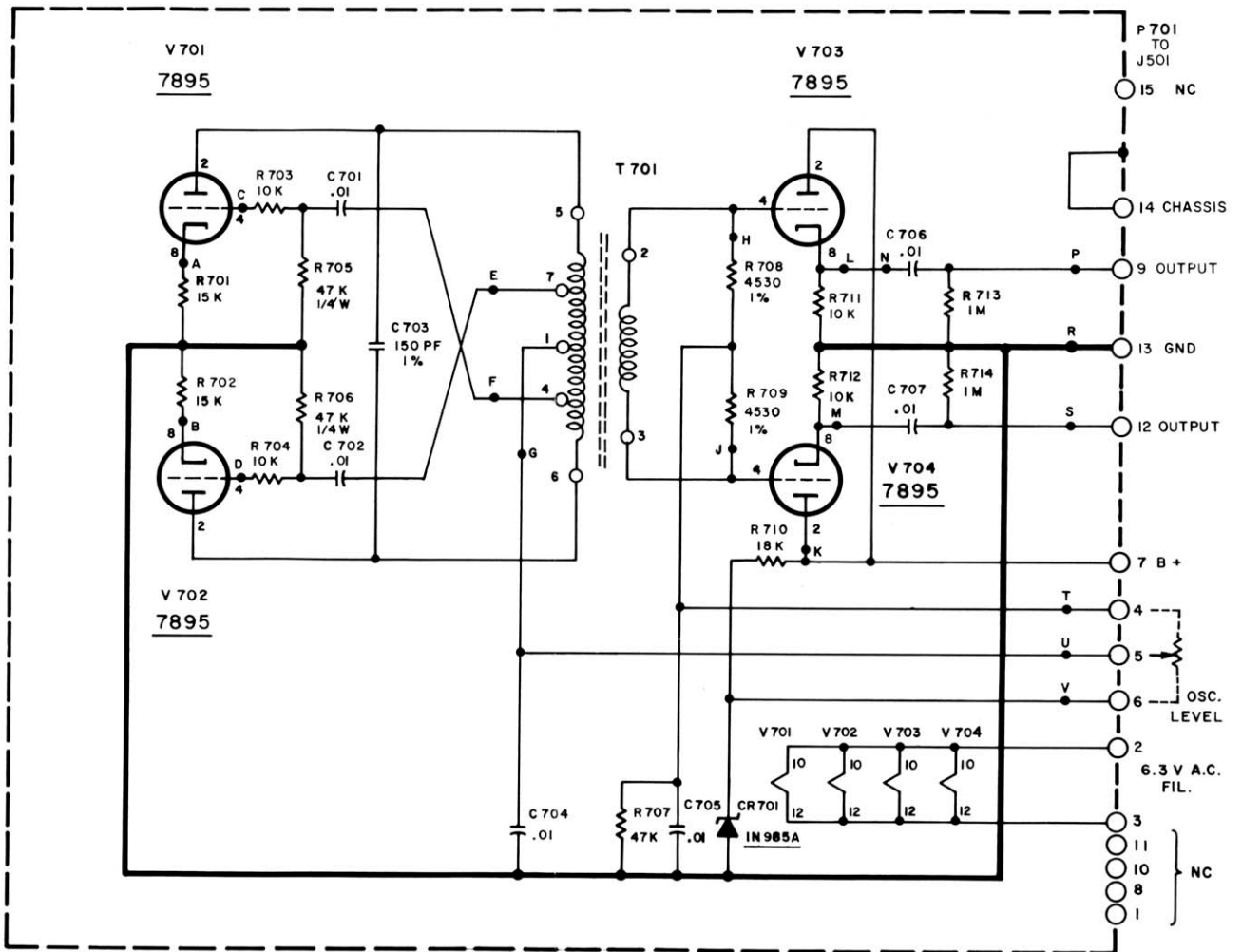

Fig. 7-7. Schematic Diagram—Master Bias Oscillator

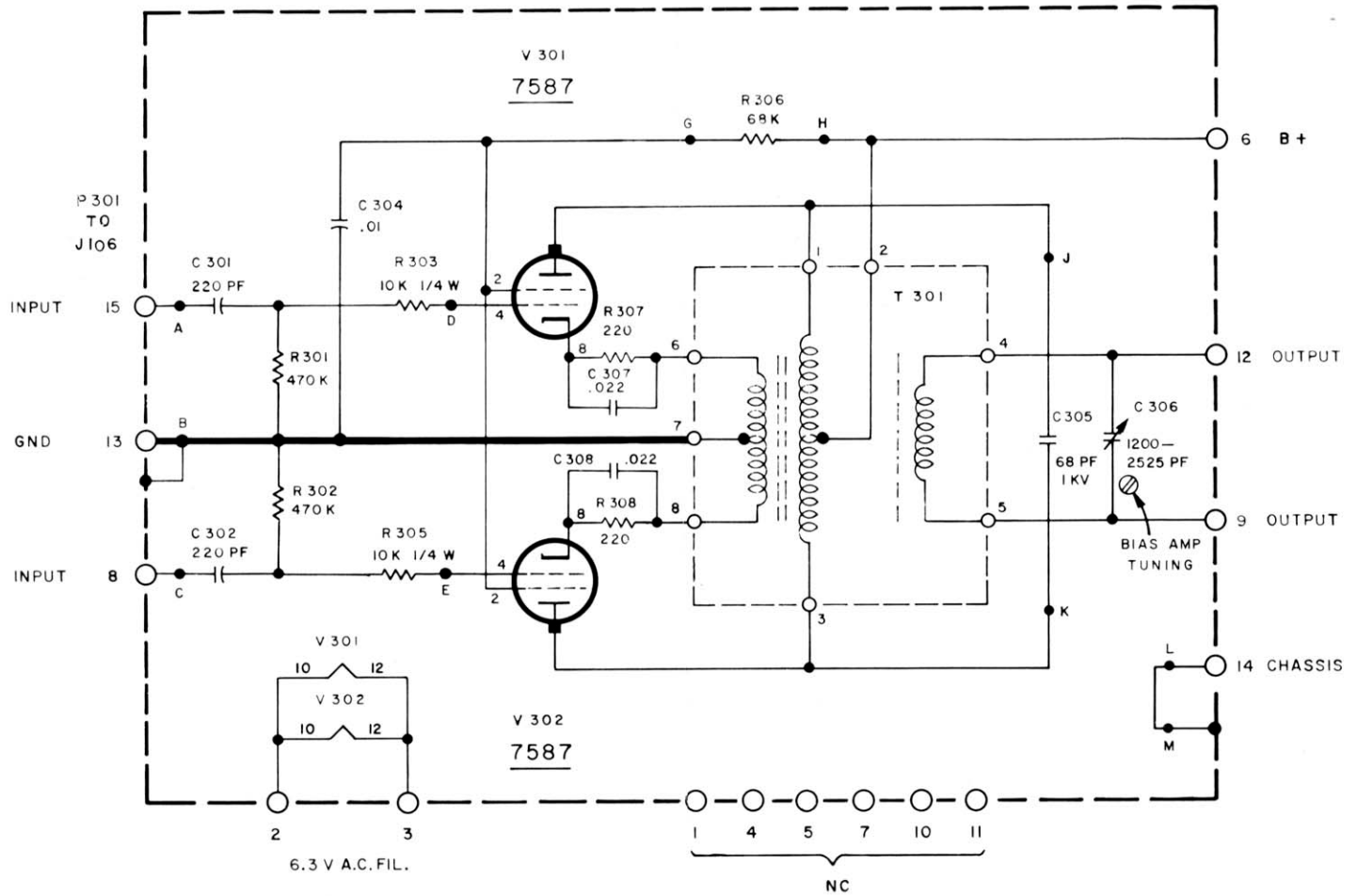

Fig. 7-8. Schematic Diagram—Bias Amplifier Module

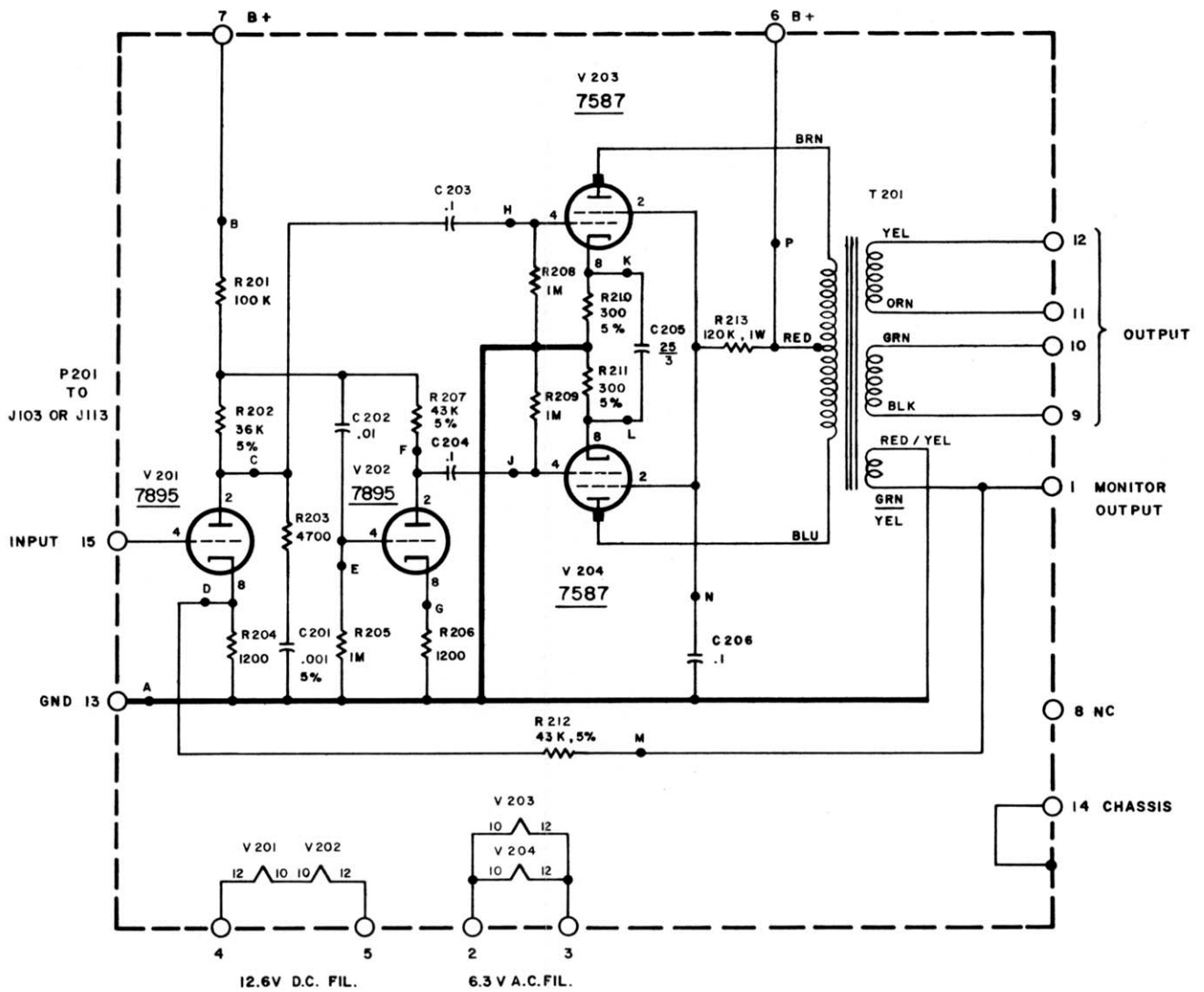

Fig. 7-9. Schematic Diagram—Output Amplifier Module

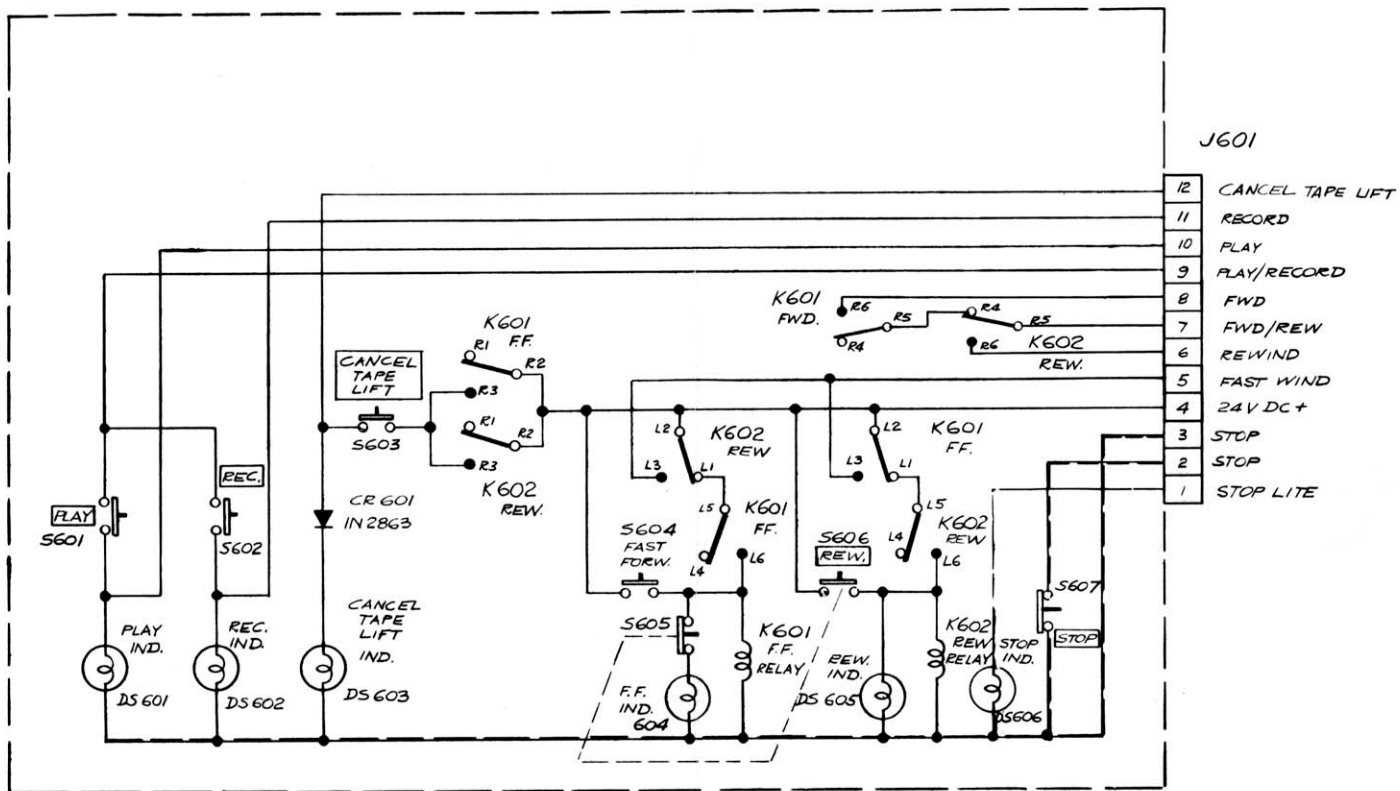

Fig. 7-10. Schematic Diagram—Remote Control, Transport

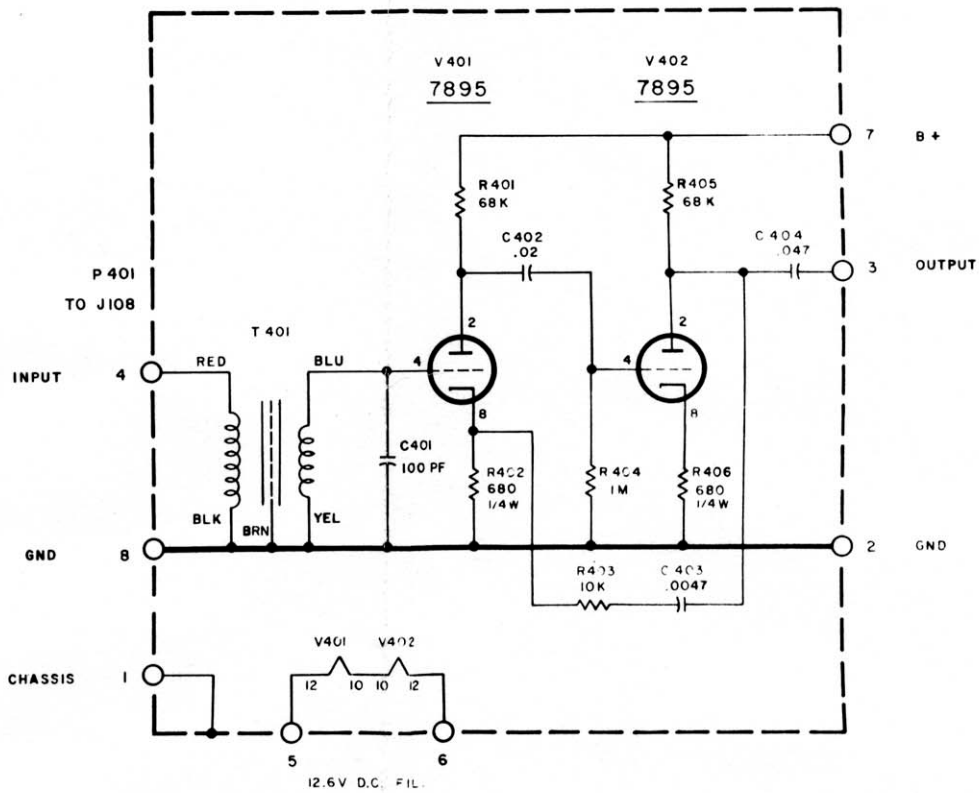
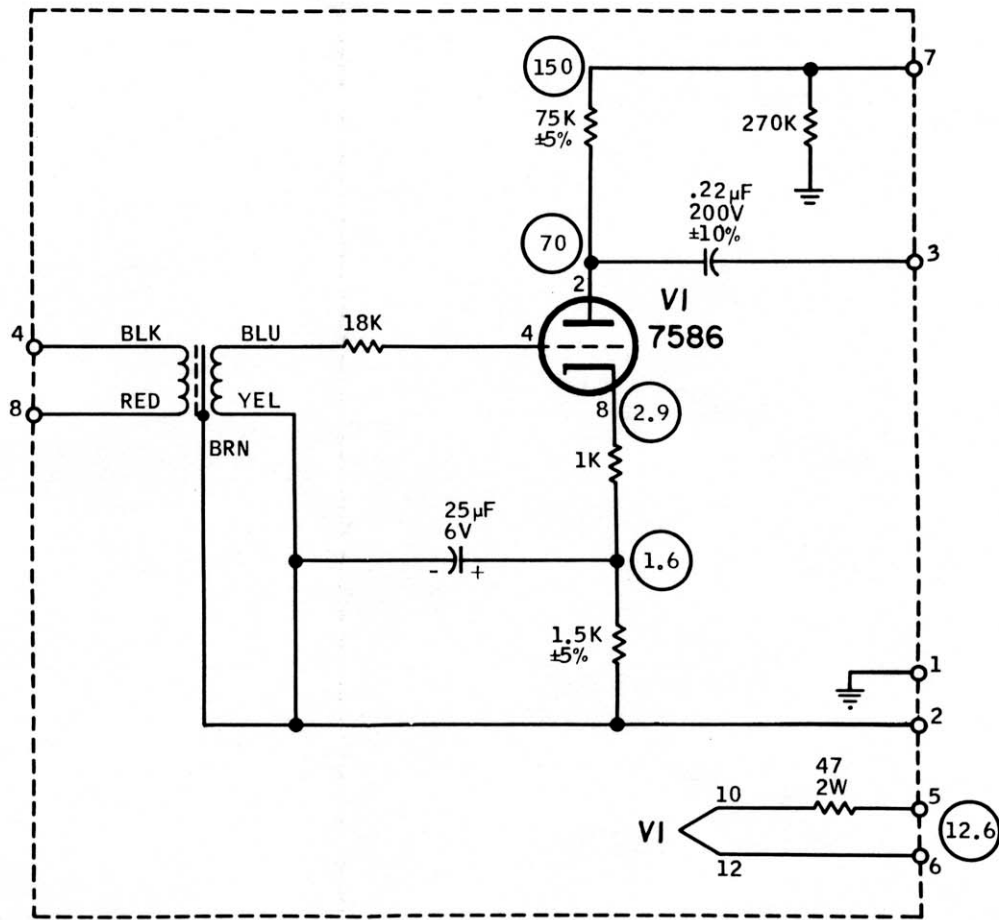

Fig. 7-11. Schematic Diagram—Sel-Sync Amplifier Module



NOTE:
UNLESS OTHERWISE SPECIFIED,
RESISTOR VALUES ARE IN OHMS
±10%, 1/2WATT.

LEGEND:
○ DC VOLTAGE.

Fig. 7-12. Schematic Diagram—Microphone Preamplifier, 40 db

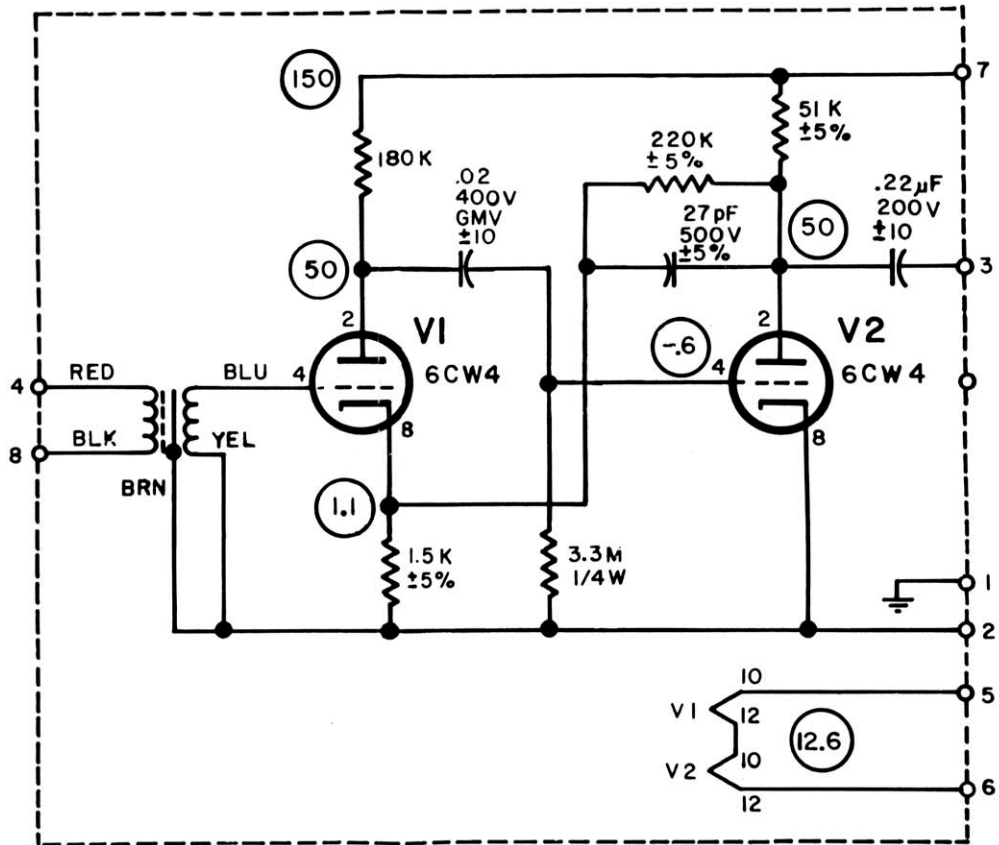

NOTE:

UNLESS OTHERWISE SPECIFIED RESISTOR
VALUES ARE IN OHMS $\pm 10\%$, 1/2 WATT

LEGEND

○ DC VOLTAGE

Fig. 7-13. Schematic Diagram—Microphone Preamplifier, 60 db

FIELD ENGINEERING BULLETIN

VOLUME II PART 7
 REFERENCE NUMBER 70089
 SHEET NUMBER 1 of 3
 MODEL NUMBER MR-70
 DATE OF ISSUE March 24, 1966
 DISTRIBUTION: C 39, D 1 & 7;
 C 60, D 3;
 C 61, D 7;
 C 66, D 6;
 C 70, D 7.

TITLE IMPROVED BIAS AMPLIFIER STABILITYI APPLICABILITY:

All Model MR-70's fabricated prior to February 1, 1966.

Mailing #66-10-22

II PURPOSE:

To eliminate the possibility of parasitic oscillations in the bias amplifier module, catalogue number 4020235-01 or 4020235-02.

III DISCUSSION:

Due to occasional instances of parasitic oscillation in the 1MHz region, a modification to the bias amplifier circuit has been incorporated in present production equipment and is recommended for all MR-70's now in service which have not been modified.

IV PARTS REQUIRED:

<u>QTY.</u>	<u>REF. NO.</u>	<u>AMPEX C/N</u>	<u>DESCRIPTION</u>
2	R307, R308	041-336	Resistor, Comp, 470 Ohms 1/2W, 5%
2	C307, C308	035-777	Capacitor, .002MF, 100V, 10%
			(Ampex 035-357 may be substituted)

V PROCEDURE:A. ASSEMBLY C/N 4020235-01

1. Remove the present bias resistor and capacitor from the center tap, pin 7, of output transformer, T301, in 4020235-01 assemblies.
2. After removing the resistor and capacitor, R304 and C303, from -01 versions, complete the cathode ground return circuit by adding a #22 insulated jumper wire in place of the deleted components.

Add new cathode resistors and by-pass capacitors R307, R308, and C307, C308 between each nuvistor cathode, pin 8, and pins 6 and 8 of T301 per attached schematic, 4840136 issue B.

B. ASSEMBLY C/N 4020235-02

3. Remove the 220 ohm resistors only from the separate cathode circuits of each nuvistor and pins 6 and 8 of the output transformer in 4020235-02 versions of the amplifier assembly.
4. Replace the 220 ohm resistors removed in #3 above with 470 ohm, 1/2 watt resistors (Ampex C/N 041-336).

BOTH A. and B.

5. For future reference it is adviseable to add a note on the amplifier assembly by marking pin or gum label:

"MODIFIED TO 4020235-03".

FIELD ENGINEERING BULLETIN

VOLUME PART
 REFERENCE NUMBER
 SHEET NUMBER
 MODEL NUMBER 70089
 DATE OF ISSUE Page 3 of 3

TITLE

SCHEMATIC --- BIAS AMP. MODULE

DRAWING NUMBER 4340136 ISSUE B

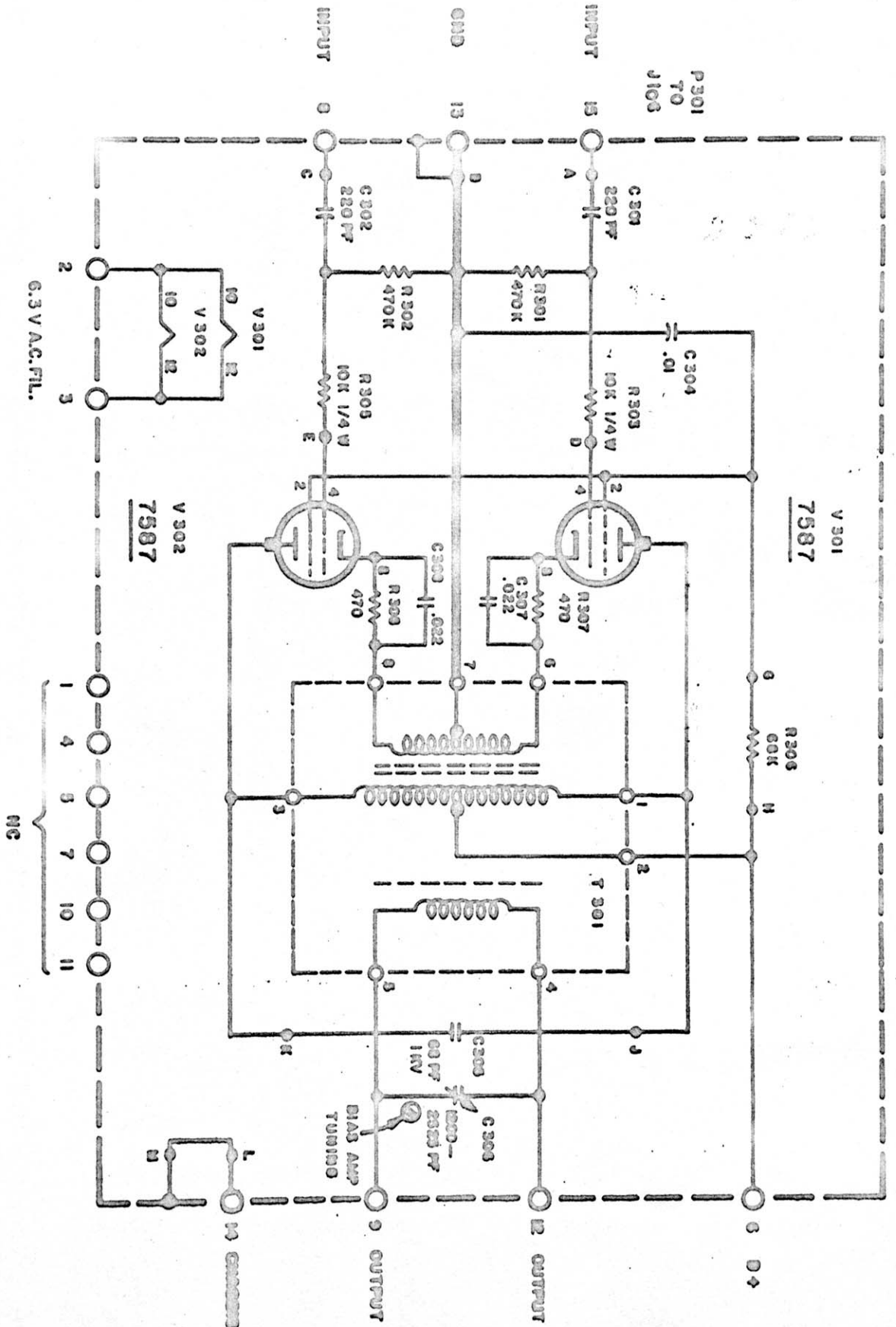

FIELD ENGINEERING BULLETIN

VOLUME II PART 7
 REFERENCE NUMBER 70104
 SHEET NUMBER 1 of 2
 MODEL NUMBER MR-70
 DATE OF ISSUE 9-28-66
 Distribution: e 39-1, 7,
 C 61,7 C 60-3
 C 66-6 C 70-7
 CCP Master and Bulk

TITLE BIAS TRAP MODIFICATION

I APPLICABILITY:

MR-70

II PURPOSE:

To prevent bias entering the sel-sync amplifier module.

III DISCUSSION:

In some instances sel-sync amplifier operation will be degraded when bias, present at the record head during sel-sync operation, enters the amplifier module through socket J 108. A trap consisting of a 1 MH choke and a .00127 PF capacitor is recommended to prevent this occurrence.

IV PARTS:

<u>Item</u>	<u>Qty.</u>	<u>Part No.</u>	<u>Description</u>
1	1	541-138	Coil, Choke, 1MH (L 105)
2	1	034-716	Capacitor, .00127 PF, 500V, 5% (C 155)
3	1	180-988	Terminal Strip

Note: One (1) each of the above per unit.

V PROCEDURE:

1. Remove the bottom cover from the electronics chassis after removing the chassis from the console.
2. At socket J108, remove the nut closest to the socket key slot. Refer to figure (2).
3. Install the terminal strip (180-988) on the screw and tighten it down with the nut removed in step 2.
- *4. Solder one lead of the capacitor (034-716) at pin 8 of socket J108 (See figure 2).
- *5. Hook other lead of the capacitor to the terminal strip but do not solder. (Figure 2).
- *6. Install one lead of the choke (541-138) at the terminal strip and solder. (Figure 2).
- *7. Solder the other lead of the choke at pin 4 of socket J108. (Figure 2).
8. Installation complete as per Figure (1), re-install bottom cover.

* NOTE: Keep all leads as short as possible.

Field Service Technical Support Section/Distributor Products Unit
 Gary W. Figg/vmj

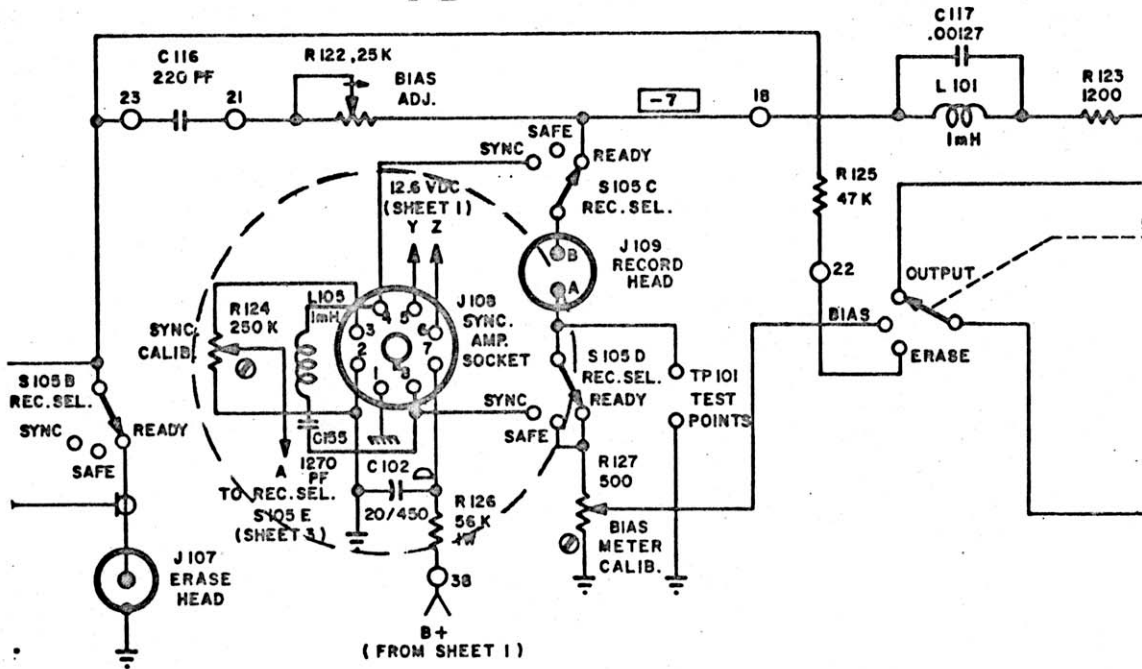

FIGURE I

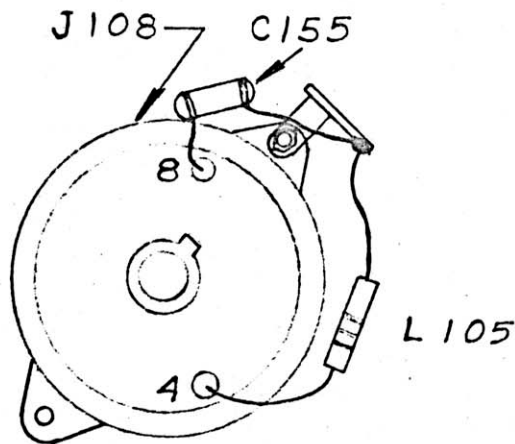
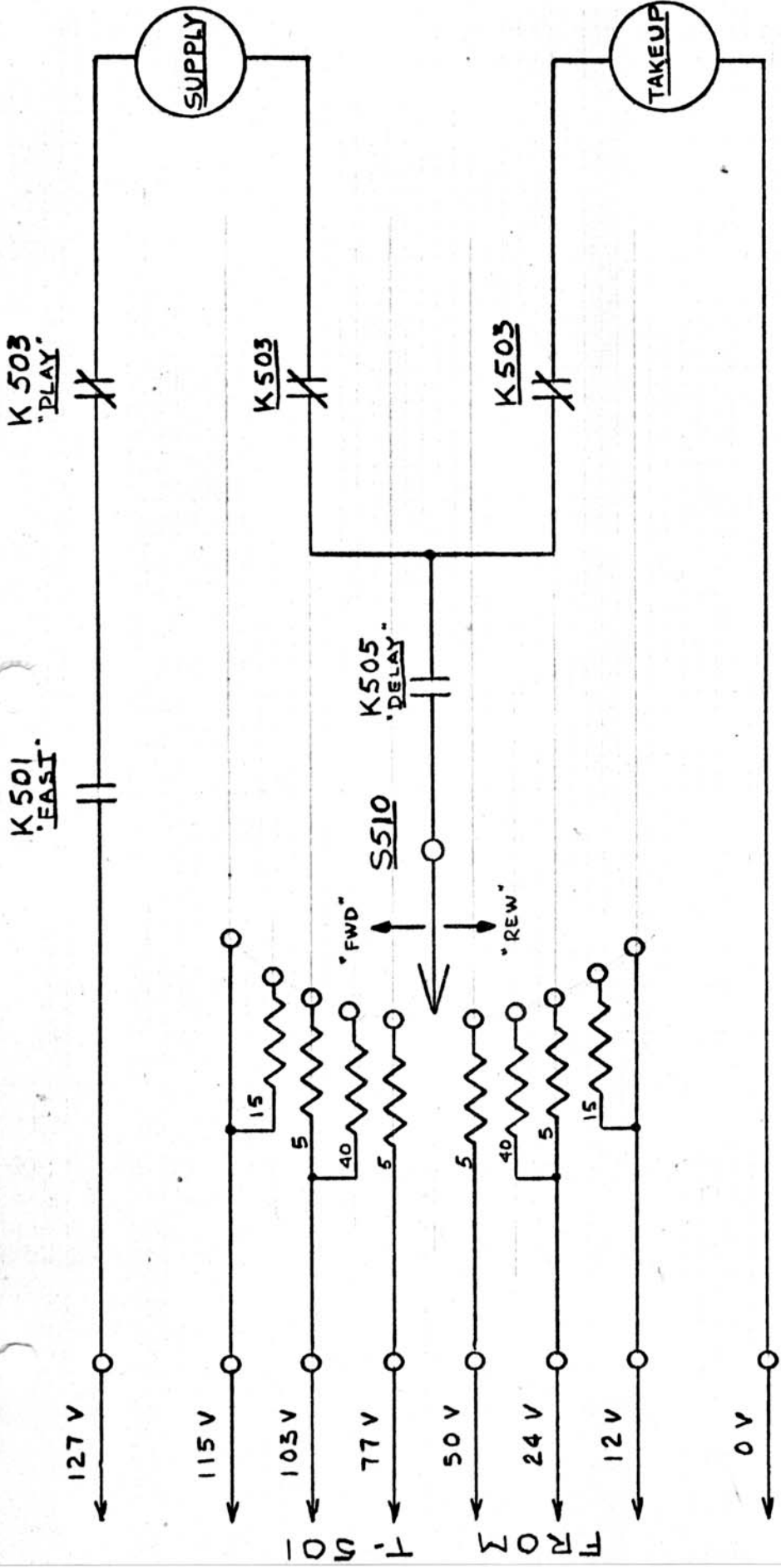

FIGURE II



"FAST" MODE
 VARIABLE 0-400 IPS

SHOWN:
 "STOP" MODE
 K501 DE-ENERGIZED
 K503 ENERGIZED
 K505 ENERGIZED *

* ~ 1/2 SEC DELAY PROPORT

MR 70