

MX-10/MX-35

MIXER ASSEMBLY

TM-2010A

89-0138

JANUARY, 1962

AMPEX CORPORATION, AUDIO DIVISION

Issue A

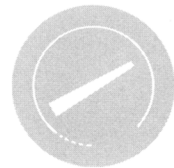
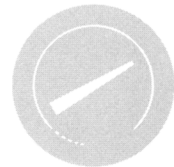
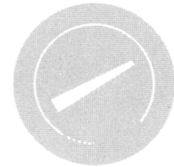
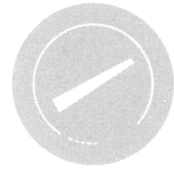

'LIST OF EFFECTIVE PAGES'

PAGE NUMBER	ISSUE IN EFFECT	PAGE NUMBER	ISSUE IN EFFECT	PAGE NUMBER	ISSUE IN EFFECT	PAGE NUMBER	ISSUE IN EFFECT
Title	A	1/62					
A	B	5/62					
i	A	1/62					
ii	A	1/62					
1-1	A	1/62					
1-2	A	1/62					
2-1	A	1/62					
2-2	A	1/62					
2-3	A	1/62					
3-1	A	1/62					
3-2	A	1/62					
3-3	A	1/62					
4-1	A	1/62					
4-2	A	1/62					
5-1	A	1/62					
5-2	A	1/62					
6-1	A	1/62					
6-2	A	1/62					
6-3	A	1/62					
6-4	A	5/62					
6-5	A	5/62					
6-6	Blank						
6-7	A	5/62					
6-8	A	5/62					
6-9	A	5/62					
6-10	A	5/62					
7-1	A	1/62					
7-2	A	1/62					
7-3	A	1/62					
(8-1)	A	1/62					
9-1	A	1/62					
9-2	A	1/62					

89-0138B 5/62

TABLE OF CONTENTS

1	INTRODUCTION	
	Use of the Instruction Manual.....	1-1
	The General Description Section.....	1-1
	The Installation Section.....	1-1
	The Operation Section.....	1-1
	The Checkout and Adjustment Section.....	1-1
	The Maintenance and Troubleshooting Section.....	1-2
	The Theory of Operation Section.....	1-2
	The Notes and Bulletins Section.....	1-2
	The Index	1-2
2	DESCRIPTION	
	General.....	2-1
	Performance Characteristics	2-1
	Equipment Applications	2-2
3	INSTALLATION	
	General.....	3-1
	Installation of Equipment.....	3-1
	Installation of Plug-In Items.....	3-1
	Connections	3-3
4	OPERATING INSTRUCTIONS	
	Controls	4-1
	Applying Power	4-2
	Setting Up the Controls.....	4-2
	Operation of the Equipment.....	4-2
5	CHECKOUT AND ADJUSTMENT	
	General.....	5-1
	Overall Gain Measurement.....	5-1
	Overall Gain Adjustment.....	5-2
	Frequency Response Measurement.....	5-2
6	MAINTENANCE AND TROUBLESHOOTING	
	General Maintenance Information.....	6-1
	Corrective Maintenance	6-1
	Ordering Parts.....	6-1
	Parts List, Mixer Assembly.....	6-3
7	THEORY OF OPERATION	
	Microphone Preamplifiers	7-1
	Output Amplifiers	7-1
	Mixer Coupling	7-2
	Power Supply	7-2
8	NOTES AND BULLETINS	8-1
	INDEX	9-1

LIST OF ILLUSTRATIONS

2	Typical Uses of the MX-10 Mixer.....	2-3
3	MX-10 Mixer Assembly — $\frac{3}{4}$ View.....	3-1
	Rack Layout (Shown with PR-10 Tape Recorder).....	3-1
	Mounting Dimensions	3-2
	Interconnecting Two or More Mixers.....	3-2
4	Operating Controls	4-1
5	Response and Gain Measurement Set-Up.....	5-1
6	Troubleshooting the Mixer.....	6-1
	Parts Location, MX-10 Mixer.....	6-9
7	Block Diagram, MX-10 Mixer.....	7-1
	Partial Schematic Diagram, Microphone Preamplifier.....	7-2
	Partial Schematic Diagram, Output Amplifier.....	7-2
	Schematic Diagram, MX-10 Mixer.....	7-3

Section 1 INTRODUCTION



Section 1

INTRODUCTION

0109

USE OF THE INSTRUCTION MANUAL

This instruction manual is intended to give the installation man, the operator, and the maintenance man the most complete and accurate information that is available.

For the installation man:

*the description section,
the installation section,
the operation section, and
the checkout and adjustment section*

are required reading.

For the operator:

*the description section,
the installation section, and
the operation section*

are required reading.

For the maintenance man:

*the description section,
the checkout and adjustment section,
the maintenance and troubleshooting
section, and
the theory of operation section*

are required reading. The installation and operation sections may also offer valuable information to the maintenance man.

THE GENERAL DESCRIPTION SECTION

The description section briefly describes the mixer assembly and its performance characteristics. This section also describes the ways in which the equipment can be used.

THE INSTALLATION SECTION

The installation section provides all necessary information for properly installing and connecting the equipment. All mounting dimensions are given for custom installation. Testing of the equipment after installation is *not* covered in this section, but rather is covered in the checkout and adjustment section which follows the operation section.

THE OPERATION SECTION

The operation section describes the operating controls and their functions, and describes how to set up and use the equipment.

THE CHECKOUT AND ADJUSTMENT SECTION

The checkout and adjustment section provides all the necessary information for checking out and adjusting the equipment. The checkout procedures are given first to ascertain whether or not the system is operating properly. This is followed by the adjustment procedures. Any malfunctions found while performing either of the above procedures, should

be corrected using maintenance procedures that will be found in the maintenance and troubleshooting section of the manual.

THE MAINTENANCE AND TROUBLE SHOOTING SECTION

The maintenance and troubleshooting section provides insuring information on maintaining functional equipment for long lasting operation. An illustrative parts location diagram and a complete parts list aids the user in locating all basic components.

THE THEORY OF OPERATION SECTION

The theory of operation section provides technical information on how the mixer works.

THE NOTES AND BULLETINS SECTION

The notes and bulletins section is a section

set aside for the user to write down any specialized operating techniques or maintenance procedures. It can also be used for setting up a regular maintenance schedule. In short, this section may be used in any manner desired.

As an aid to the user, Ampex publishes service bulletins and operation bulletins from time to time. This section can (and should) also be used to keep these bulletins together in a central location.

THE INDEX

In an attempt to give as complete a manual as possible, the index is included to aid in locating the required information as quickly as possible.

Section 2 DESCRIPTION

Section 2 DESCRIPTION

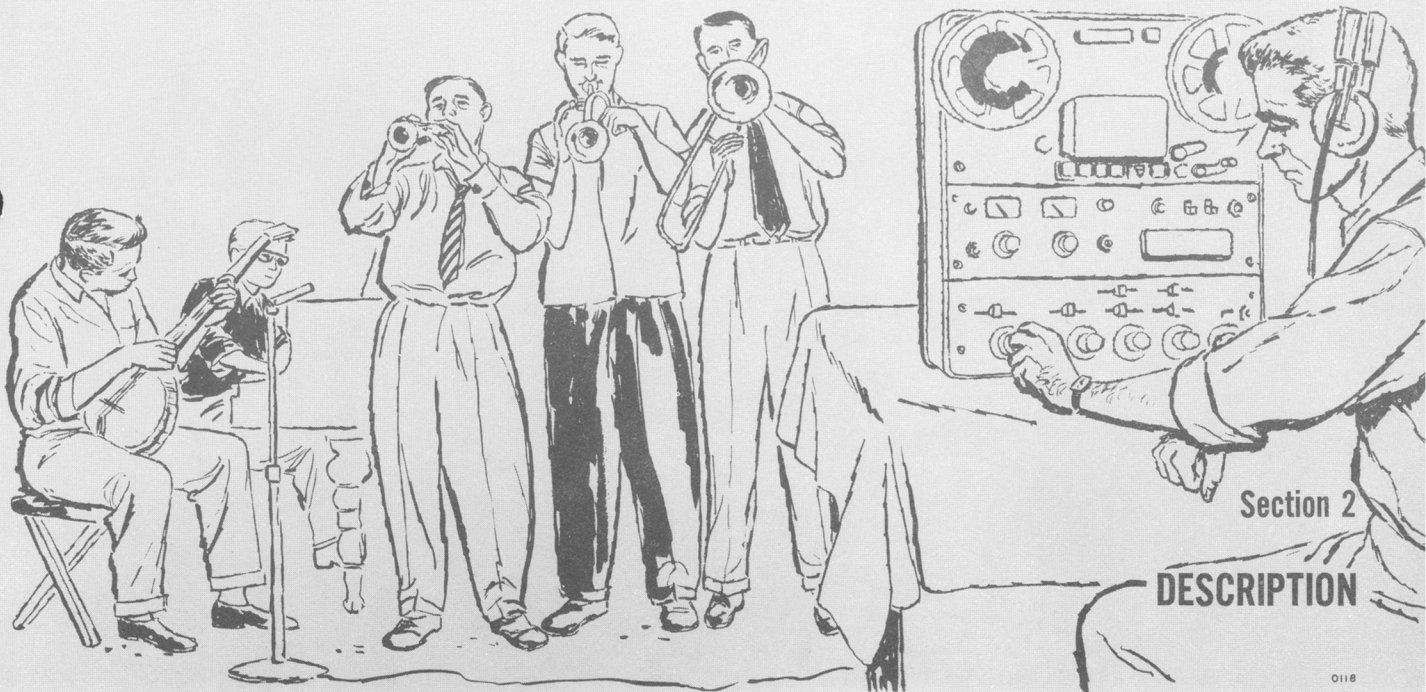

GENERAL

The Ampex MX-10 and MX-35 Mixer Assemblies provide complete mixing facilities. Six inputs and two outputs are provided. The inputs consist of four microphone inputs and two line inputs. Switching allows any combination of up to four inputs to be connected to either or both outputs. Provisions are also made for coupling up to four mixer assemblies together.

The mixer assembly consists of a single chassis on which is mounted four separate and completely independent microphone preamplifiers and two separate output amplifiers.

Switching allows any microphone preamplifier to be connected to either or both of the output amplifiers. Additional switching is provided to bypass two of the microphone preamplifiers (separately) so that two line inputs can be connected to either or both outputs. Individual gain controls are provided as is a master gain control.

On the back panel of the mixer assembly are all connecting and interconnecting provisions for line and microphone inputs, line outputs, power and mixer coupling. A screw-type fuse post is also provided on the chassis back panel.

PERFORMANCE CHARACTERISTICS

Inputs:

Four low level microphone inputs and two high level line inputs, any combination of four being available at any one time; incorporating high level mixing.

Input Impedance:

Microphone: 200 ohm non-terminating; Line: 100K ohms unbalanced bridging (20K ohm balanced bridging with optional plug-in transformer).

Outputs:

Two 1 volt normal output level; 30 volts maximum output level when fed to a bridging input with an input impedance of at least 100K ohms. Cable capacity should not exceed 0.001 microfarad to preserve high frequency response.

PERFORMANCE CHARACTERISTICS (CONTD.)

<i>Gain:</i>	Sufficient to produce a 1 volt output with an input signal of -65 dbm on any microphone channel and -20 dbm on any line channel for maximum control settings.
<i>Frequency Response:</i>	\pm 1db 40 to 15,000 cycles per second.
<i>Noise:</i>	65 db below signal for inputs of -55 dbm. This represents a noise equivalent to an input signal of -120 dbm.
<i>Distortion:</i>	Microphone Preamplifier: (distortion characteristics as a function of input level) 30 cycles— Less than 0.2% at -52 dbm input level Less than 0.4% at -42 dbm input level Less than 1.0% at -32 dbm input level 500 to 15,000 cycles— Less than 0.1% at -53 dbm input level Less than 0.3% at -43 dbm input level Less than 1.0% at -29 dbm input level Line Output: (distortion characteristics—at nominal gain—as a function of output level) 30 cycles— Less than 0.2% at 1 volt output level Less than 0.4% at 10 volt output level Less than 1.0% at 25 volt output level 500 to 15,000 cycles— Less than 0.3% at 25 volt output level
<i>Crosstalk Rejection:</i>	65 db at 500 cycles, 50 db at 10KC.
<i>Controls:</i>	Four Allen-Bradley potentiometers (calibrated step type available on special order); master gain (two gang) potentiometer; key switches for selection of microphone or line on two input positions; key switches for channel A, both or channel B on each mixer position; ac line switch; mixer coupling switch (located on the back of the chassis) two screwdriver adjust level set controls (located on the chassis).
<i>Connectors:</i>	Cannon "XL" type on all input and outputs except for a terminal strip used for mixer coupling.
<i>Power Input:</i>	105-125 volts, 50-60 cycles, 30 watts.
<i>Tubes:</i>	Six EF86/6267's and one 12AU7.
<i>Dimensions:</i>	5 - 7/32" H, 19" L, and 5 - 3/16" D (for 5 - 1/4" rack space or portable case).
<i>Accessories:</i>	Plug-in balanced bridging line input transformer (Cat. No. 58-0116-01), and plug-in balanced matching line input transformer (Cat. No. 58-0116-02).

EQUIPMENT APPLICATIONS

The MX-10 and MX-35 Mixer Assemblies are compact, flexible speech input systems that have numerous applications in the tape recording and

sound reinforcing fields. In the tape recording field, when used with a professional quality recorder such as the Ampex PR Series, applications include: the recording of live pro-

gram material, both stereophonic and monophonic; and the dubbing of live program material over previously recorded material, both stereophonic and monophonic. In the sound reinforcing field, the mixer assembly can be used to advantage in plant paging systems and in public address or sound reinforcing installations because it permits great flexibility of switching and channel combinations. The following paragraphs and illustrations are intended to show some of the basic applications.

For the stereo recording of a live program, one basic set-up is to connect four microphones to the mixer and, using the channel selector switches, feed the "left" microphone to Ch. A, the "center" and "solo" microphones to both channels, and the "right" microphone to Ch. B.

For dubbing live stereo program material over a previously recorded stereo program, one basic set-up is to connect two microphones to microphone inputs 1 and 2 of the mixer and the outputs of a stereo tape reproducer to line inputs 1 and 2. Using the channel selector switches, feed the "left" microphone and the "left" line to Ch. A and feed the "right" microphone and the "right" line to Ch. B.

The basic set-up for monophonic recording of a live program is similar to the set-up

described for stereo, the basic difference being that all microphones are fed to Ch. A only (or to both channels when making a second simultaneous "protection" recording).

All of the above applications have considered only one mixer assembly and only one or two channel operation. Still considering one or two channel operation, two or more mixer assemblies (up to four) can be "coupled" together to provide additional inputs. Further, two or more mixer assemblies can be "stacked" together (without coupling) to provide additional channels (up to four channels can be provided with only two mixer assemblies). Finally, mixer assemblies can be both "coupled" and "stacked" in almost any combination desired. All of these applications are, of course, only basic and many variations are possible, limited only by the user's imagination and skill.

NOTE

The coupling switch transfers the output of Ch. A and the output of Ch. B from the SINGLE MIXER NORMAL to the MIXER COUPLE condition simultaneously, therefore the channels of one mixer cannot be coupled to the channels of another mixer separately.

STEREO RECORDING (LIVE)

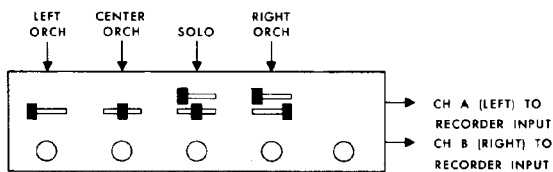

STEREO RECORDING (DUBBING)

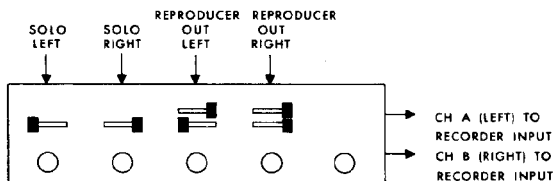

NOTES:

1. IF A SECOND "PROTECTION" RECORDING IS DESIRED, THE "CH A-BOTH-CH B" SWITCHES SHOULD BE IN THE "BOTH" POSITION.

MONOPHONIC RECORDING (LIVE)

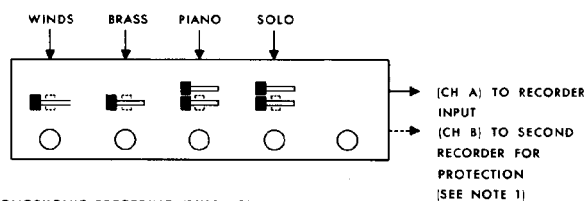

MONOPHONIC RECORDING (DUBBING)

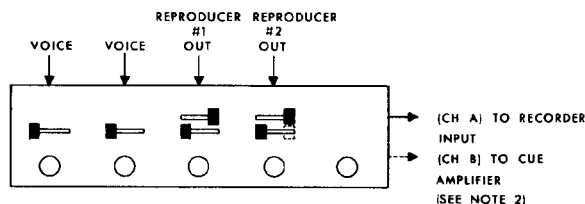

2. REPRODUCER #2 CAN BE "CUE'D" WHILE RECORDING FROM OTHER INPUTS BY SWITCHING "CH A-BOTH-CH B" SWITCH TO "CH B".

0080

Typical uses of the MX-10 mixer

Section 3 INSTALLATION



GENERAL

The MX-10 and MX-35 Mixer Assemblies will be shipped in unmounted form only. An accessory case (Cat. No. 01-96940-01) is available in which the MX-10 may be mounted along with the PR-10 tape transport and associated electronic assembly. The MX-35 may be mounted in the Catalog No. 15-0211-00 carrying case.

All necessary hardware will be included with each mixer for mounting in a rack or in the portable case.



MX-10 mixer assembly — 3/4 view

INSTALLATION OF EQUIPMENT

When the mixer assembly is to be custom installed, the equipment can be mounted on a standard 19-inch relay-type rack. Mounting

dimensions for the mixer assembly are shown in the accompanying illustration.



Rack layout (shown with PR-10 Tape Recorder)
INSTALLATION OF PLUG-IN ITEMS

The only plug-in items available for the mixer assemblies are the balanced bridging line input transformer (Catalog No. 58-0116-01)

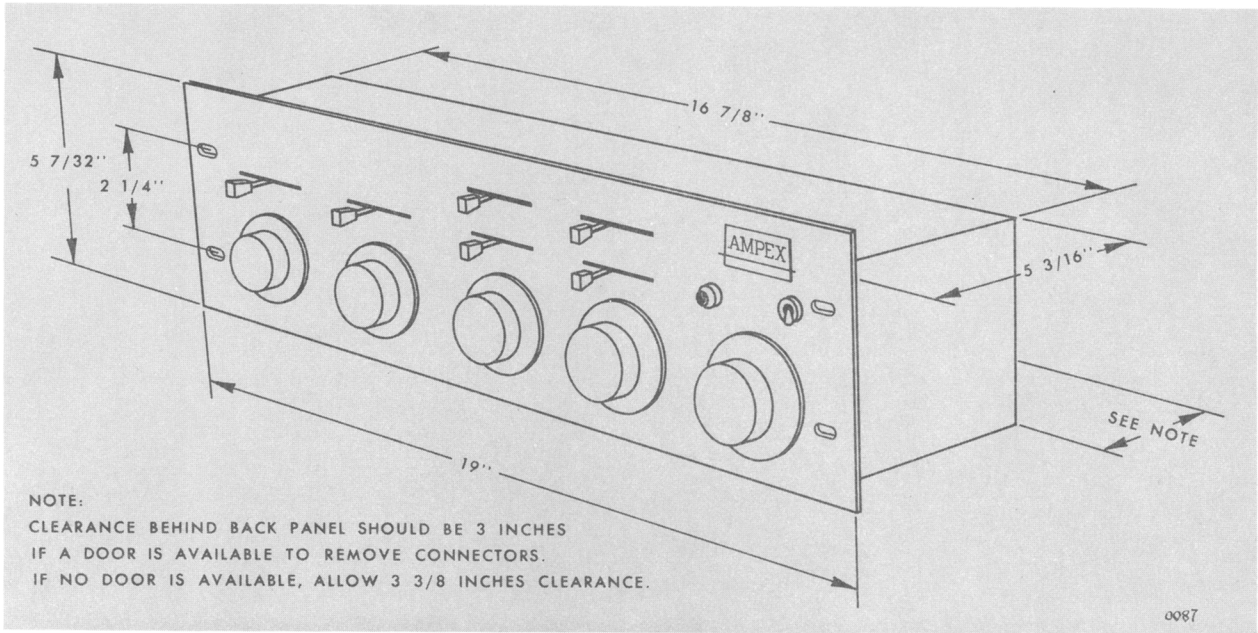

Mounting dimensions

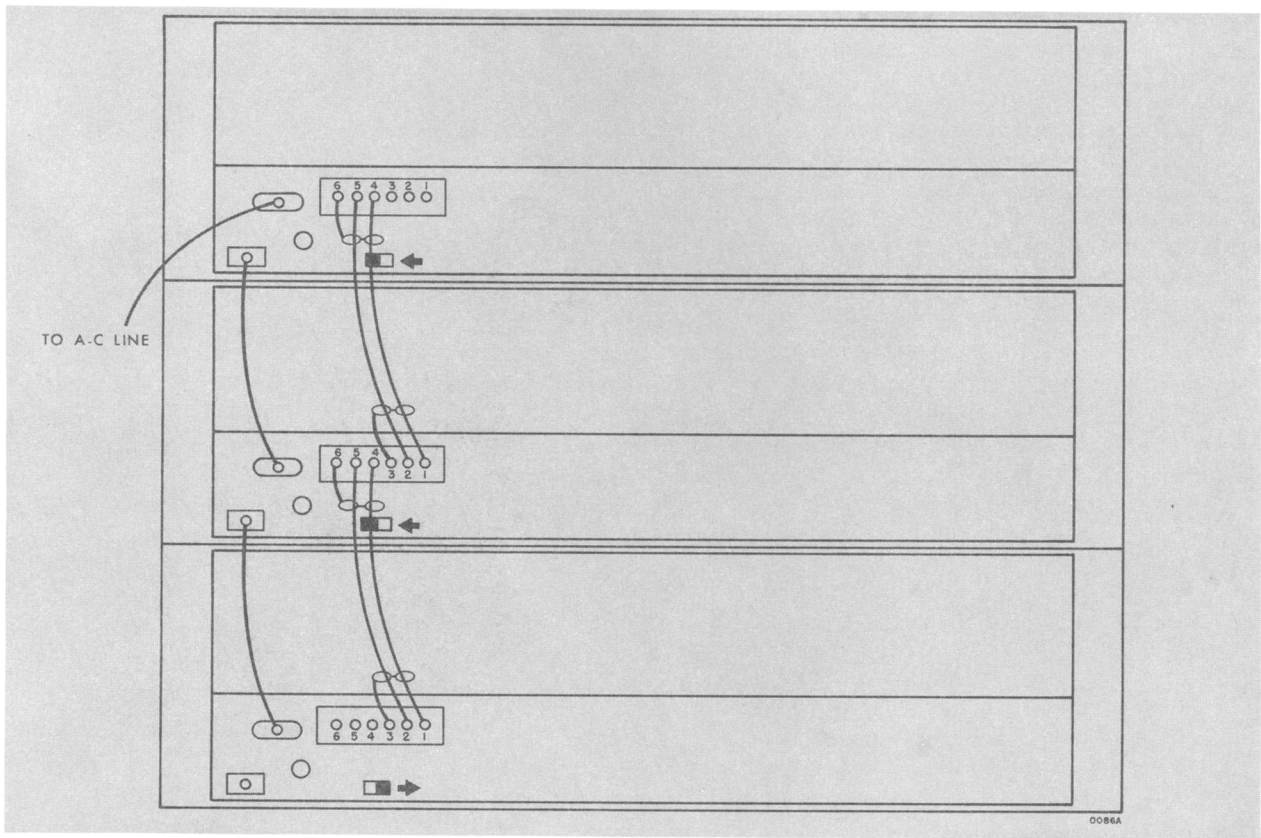

Interconnecting two or more mixers

and the balanced matching line input transformer (Catalog No. 58-0116-02). When either transformer is to be used, it should be plugged into socket J7S and/or J8S.

If the transformers are *not* used, the dummy plug (Catalog No. 03-0034-01), which is supplied with the equipment, *must* be plugged into socket J7S and/or J8S.

CONNECTIONS

Connect the power cable from the a-c power input connector, J12P, on the mixer assembly to a convenient 117 volt a-c power source. Connect the *OUTput* connectors, J9P and J10P, of the mixer to the input connectors of the equipment with which the mixer assembly is to be used.

If more than four inputs are required, additional mixers must be used. In this case, the coupled mixer terminal strip TS1 (pins 4, 5 and 6) of the *first* mixer should be connected to the coupled mixer terminal strip TS1 (pins 1, 2 and 3) of the *second* mixer and the coupled mixer terminal strip TS1 (pins 4, 5 and 6) of the *second* mixer should be connected to the coupled mixer terminal strip TS1 (pins 1, 2 and 3) of the *third* mixer, etc. The *OUTput* connectors of the *last* mixer should be connected to the user's equipment. The coupled mixer switch, S7, on the rear of each of the mixers, *except the last one*, should be

in the MIXER COUPLE position. The coupled mixer switch on the last mixer should be in the SINGLE MIXER NORMAL position. When two or more mixers are coupled together in this manner, there are still *only two outputs*. The "master gain" control on the *last* mixer assembly controls overall gain while all other "master gain" controls become inoperative.

If more than two outputs are required (i.e., 3 channel operation), additional mixers are also required. In this case, however, the mixers are *not* coupled together as previously described, but rather, each mixer is connected as described for single mixer operation.

Connect the inputs (lines and/or microphones) to the mixer(s) as desired.

NOTE

The MX-10 Mixer Assembly is specifically designed for use with the Ampex PR Series Tape Recorder/Reproducer and the MX-35 Mixer Assembly is specifically designed for use with the Ampex 351/354 Recorder/Reproducers. Use of the mixers are, however, not limited to these recorders. The mixers may be used with any electronics equipment that has an input impedance of at least 100,000 ohms and requires 1 volt rms input or less for proper operation. Cable capacity should not exceed 1000 uuf to preserve high frequency response.

Section 4 OPERATING INSTRUCTIONS



Section 4

OPERATING INSTRUCTIONS

0136

CONTROLS

On the front panel of the mixer assembly are facilities for setting the levels of the individual inputs and the combined outputs. Switching allows each input to be fed to either or both outputs and additional switching allows the selection of either mike or line input

in the No. 3 and No. 4 mixer position. All switching regardless of combination maintains proper balance and isolation between channels.

The following table describes the function of each operating control. All controls listed are on the front panel of the mixer unless otherwise noted.

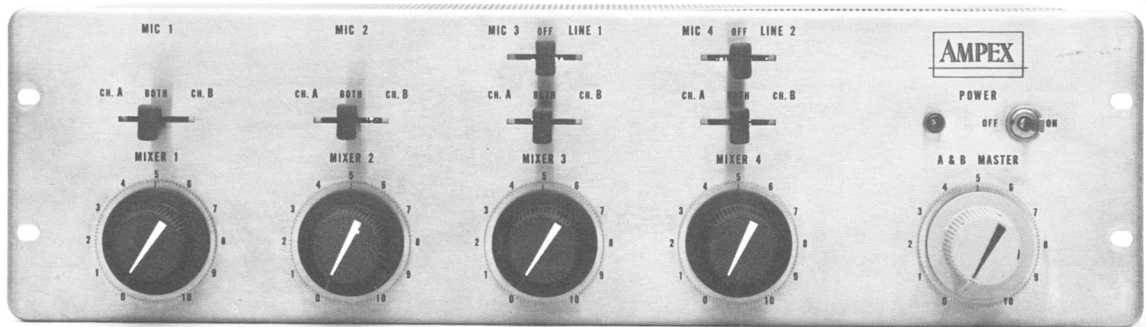

0081

Operating controls

<i>Item</i>	<i>Ref Sym</i>	<i>Function</i>
POWER ON-OFF SWITCH	S8	Controls power to the mixer assembly. Indicator lamp DS1 is lit when power is ON.
MICROPHONE-LINE SWITCH	S1 S2	Used to select Microphone 3 or LINE 1 (switch S1) and Microphone 4 or LINE 2 (switch S2). When in the center (OFF) position, no output is obtained from that mixer position.

CH. A - CH. B SELECTOR SWITCH	S3 S4 S5 S6	Used to feed the input to either or both of the outputs.
MIXER LEVEL	R5 R10 R15 R21	Adjusts the level of the individual inputs.
A & B MASTER LEVEL	R53	Adjusts the level of the combined inputs.
COUPLED MIXER SWITCH	S7 (rear panel)	Allows two or more mixer assemblies to be coupled together.
LEVEL SET	R32 (Chas R36 sis)	Adjusts the overall gain and balance of the mixer assembly.

APPLYING POWER

Power is supplied through POWER switch S8 which must be turned on to operate the mixer assembly. If more than one mixer assembly is used, the POWER switch on each mixer must be turned on. The mixer assembly is fused by the $\frac{3}{4}$ ampere fuse F1.

Turn the individual MIXER gain controls to provide sufficient signal strength and proper balance, taking care that the combined inputs do not overload the associated equipment.

When a high output level microphone (−30 dbm or higher) is used, it is preferable to turn down the individual MIXER gain controls rather than the A & B MASTER gain control.

SETTING UP THE CONTROLS

NOTE

To avoid overloading the user's equipment, the gain controls should ALL be turned to 0 (maximum counter-clockwise rotation) before starting the following procedure.

Set the gain controls on the associated equipment to the desired position. Set the channel selector switches and MICrophone-LINE selector switches on the mixer as desired. Set the A&B MASTER gain control on the mixer assembly to approximately 12 on the dial.

Turn the associated reset dials on the mixer assembly to the corresponding position for the control concerned so that the gain controls may be turned down and then returned to the same volume (as with fading in or out).

OPERATION OF THE EQUIPMENT

After the controls and reset dials have been set as outlined in the preceding paragraph, operation consists of varying the controls (around the gain indicated by the reset dials) in accordance with the program material. Beyond these operating instructions, operation is a matter of personal preference and proficiency.

Section 5

CHECKOUT AND ADJUSTMENT

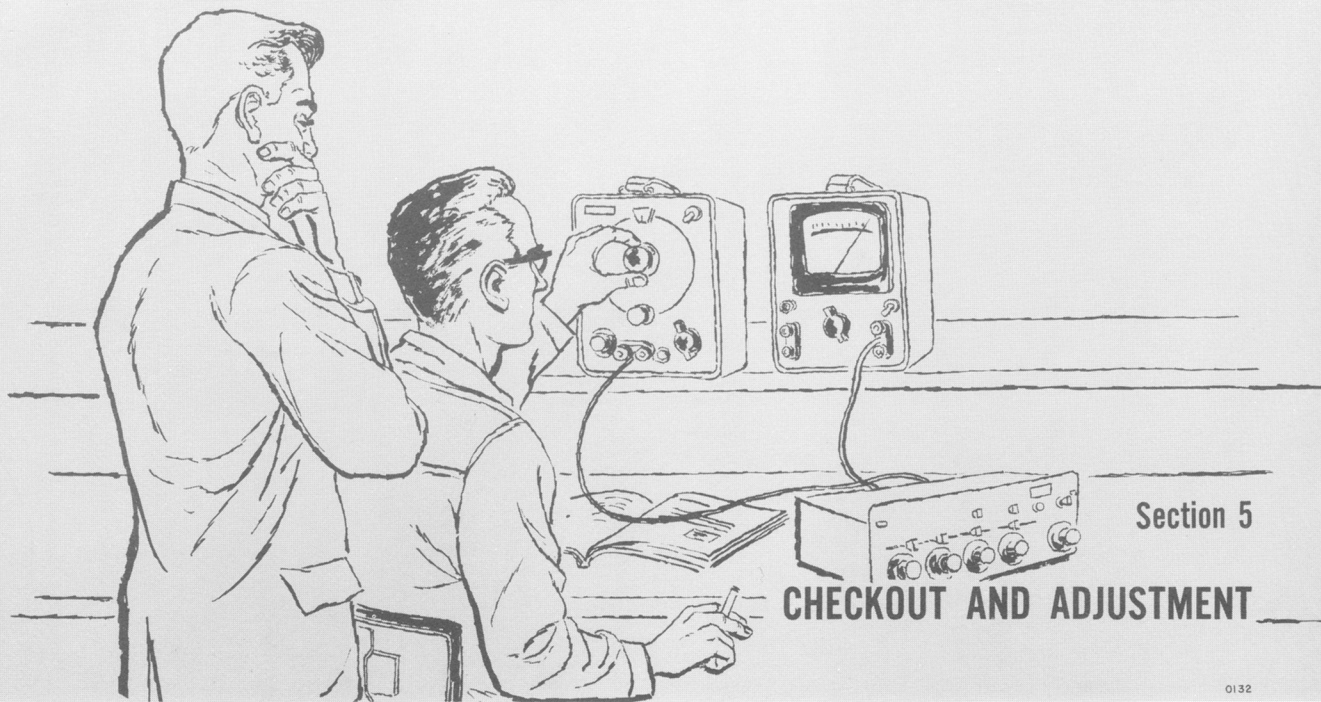

Section 5

CHECKOUT AND ADJUSTMENT

0132

GENERAL

In the following checkout and adjustment procedures, each input and each channel should be treated separately. That is, check microphone 1 input through channel A first, then microphone 1 input through channel B followed by microphone 2 input through channel A, etc. The sequence (which input and which channel is checked first) is unimportant.

Test equipment required for proper checkout and adjustment consists of an ac vacuum tube voltmeter capable of indicating rms voltages of 0.004 or less (Hewlett-Packard Model 400D or equivalent) and an audio oscillator with stable output from 50 cps to 15KC (Hewlett-Packard Model 200A or equivalent).

OVERALL GAIN MEASUREMENT

With all front panel level controls set at maximum and with the LEVEL SET controls (screwdriver adjust) set at their nominal positions, a 1.0 volt output is achieved with a -55 dbm microphone input or with a -10 db line input. Because the db scale of the Hewlett-Packard Model 400D is calibrated with respect to a reference level of one milliwatt into 600 ohms and the nominal characteristic input impedance of the microphone preamplifiers is 200 ohms (a difference of 5 db), the gain from the microphone input *appears* to be 60 db using the test set-up illustrated.

NOTE

There is an adjustment of ± 10 db from this nominal gain and if a different setting of the LEVEL SET controls is used, the input and/or output levels shown on the test set-up illustration will have to be modified accordingly.

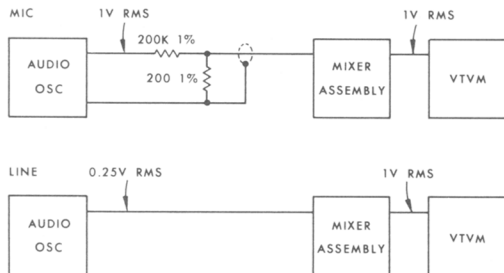

0679

Response and gain measurement set-up

Step 1:

Connect the audio oscillator and the vtm as shown in the test set-up. Set the oscillator at 500 cps.

Step 2:

Set all front panel level controls at maximum.

Step 3:

Set the oscillator output level at 1 volt rms for the microphone input or 0.25 volt rms for the line input. Output of the mixer assembly should be 1 volt rms as read on the vtvm. (See NOTE above.)

OVERALL GAIN ADJUSTMENT

To set the overall gain of the mixer assembly to the nominal value (or any other value within 10 db of the nominal), use the following procedure.

Step 1:

Connect the audio oscillator and the vtvm as shown in the test set-up. Set the oscillator at 500 cps.

Step 2:

Set all front panel level controls at maximum.

Step 3:

Set the oscillator output level at 1 volt rms for the microphone input or 0.25 volt rms for the line input. (See NOTE in the GAIN MEASUREMENT paragraph.)

Step 4:

Adjust the LEVEL SET control to produce a 1 volt rms output as read on the vtvm. (See NOTE in the GAIN MEASUREMENT paragraph.)

FREQUENCY RESPONSE MEASUREMENT

Step 1:

Connect the audio oscillator and the vtvm as shown in the test set-up. Set the oscillator at 500 cps.

Step 2:

Set all front panel level controls at maximum.

Step 3:

Set the oscillator output level at 1 volt rms for the microphone input or 0.25 volt rms for the line input (or to the value used in setting the gain in the GAIN ADJUSTMENT paragraph).

Step 4:

Make a frequency response check by using at least ten discrete frequencies between 30 and 15,000 cps. The output level of the mixer assembly should not vary more than plus or minus one db from the normal output.

Section 6 MAINTENANCE AND TROUBLESHOOTING



Section 6

MAINTENANCE AND TROUBLESHOOTING

0137

GENERAL MAINTENANCE INFORMATION

Careful periodic performance checks will ensure excellent equipment operation. When the system is set up according to the instructions in this manual, equipment performance should meet the high Ampex standards.

CORRECTIVE MAINTENANCE

The first step in any corrective maintenance procedure is localizing the faulty circuit. A run through of the alignment and performance checks of the mixer assembly will help isolate the trouble and the faulty component then should be easily identifiable. A circuit for trouble shooting the mixer after the performance checks have been made (especially useful if the trouble has not been isolated) is shown below (see also—PARTS LOCATION-MIXER ASSEMBLY, and SCHEMATIC DIAGRAM-MIXER ASSEMBLY).

Disconnect any input or output when using this circuit. Using a vtvm probe and working

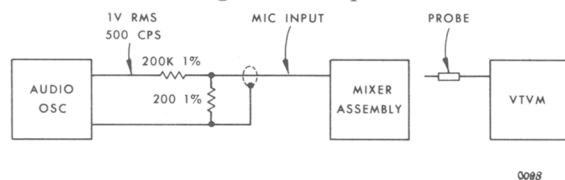

Troubleshooting the mixer

back from the output toward the input, check at the grid and plate of each stage until a signal is indicated on the vtvm. The trouble then is probably in the stage immediately following that point. When the faulty stage is located, the individual components can be isolated by a check of resistance and voltages. Typical voltage readings are shown on the foldout schematic diagram; voltages measured will vary with line voltage, the voltages indicated on the schematic diagram were measured with a 117 volt line voltage.

ORDERING PARTS

The purpose of the parts list is to aid the user of AMPEX equipment in obtaining replacement parts. AMPEX franchised dealers can offer the most convenient service in providing normally replaceable parts when proper information is furnished. Parts are listed according to the schematic reference symbol, a description of the part and the AMPEX number.

On occasion, AMPEX offers certain replacement parts that are not necessarily exact replicas of those used on the original version of the equipment; but these parts are directly interchangeable with the original parts or data is provided to enable the use of the new part. The description column names the part, its composition, electrical value and manufactur-

er's number (or military specification when available)—and the AMPEX PART NUMBER.

Ampex part numbers are the exact designation for all parts used in Ampex equipment. For example: CAPACITOR, fixed; ceramic, 0.02 μ f +80% -20%, 500 vdcw; Sprague Part No. 36C205 will always bear the Ampex Catalog Number 54-0265. THIS IS THE NUMBER

THAT SHOULD BE USED WHEN ORDERING REPLACEMENT PARTS. The schematic reference number should NOT be used for ordering parts as the part value may vary with different equipment types. Include the following information when ordering parts: Equipment Type, Equipment Serial Number, Ampex Part Number, and Description of Part. Example: 4 ea. 54-0265 capacitors for Model MX-10 (or MX-35) Mixer Assembly.

REF. NO.

PART DESCRIPTION

AMPEX PART NO.

REF. NO.	PART DESCRIPTION	AMPEX PART NO.
	MIXER ASSEMBLY, MX-10: Catalog No. 01-96900-01	
	MIXER ASSEMBLY, MX-35: Catalog No. 01-96910-01	
C1	CAPACITOR, Fixed: mylar; 0.33 mfd; $\pm 10\%$; 400 vdcw; Goodall Type 623	035-957
C2	CAPACITOR, Fixed: electrolytic; 50 mfd; -10% $+250\%$; 6 vdcw; Sprague Part No. TVA1100	031-123
C3	CAPACITOR, Fixed: electrolytic; 10-10-10-10 mfd; -10% $+50\%$; 450 vdcw; Mallory Part No. FP-434	031-077
C4	(Same as C1)	035-957
C5	(Same as C2)	031-123
C6	(Same as C1)	035-957
C7	(Same as C2)	031-123
C8	(Same as C1)	035-957
C9	(Same as C2)	031-123
C10	CAPACITOR, Fixed: ceramic; 0.05 mfd; -20% $+100\%$; 30 vdcw; Centralab Part No. DA-503	030-126
C11	(Same as C10)	030-126
C12	CAPACITOR, Fixed: electrolytic; 20-20-20-20 mfd; 450 vdcw; Sprague Type DFP	031-074
C13	CAPACITOR, Fixed: electrolytic; 40 mfd; $\pm 10\%$; 250 vdcw; Sprague Part No. TVL1519	031-161
C14	CAPACITOR, Fixed: mylar; 0.1 mfd; $\pm 10\%$; 400 vdcw; Cornell Dubilier Part No. WMF4P1E	035-999
C15	(Same as C14)	035-999
C16	CAPACITOR, Fixed: mylar; 0.47 mfd; $\pm 20\%$; 400 vdcw; Cornell Dubilier Part No. WMF4P47E	035-981
C17	(Same as C16)	035-981
C18	CAPACITOR, Fixed: electrolytic; 2000 mfd; -10% $+250\%$; 15 vdcw; Mallory Part No. WP-041	031-085
C19	CAPACITOR, Fixed: paper; 0.0047 mfd; $\pm 20\%$; 600 vdcw; Sprague Part No. 73P47206	035-028
C20	(Same as C19)	035-028
C21	CAPACITOR, Fixed: ceramic; 4.7 pfd; $\pm 10\%$; 500 vdcw; Erie Type 831	54-0289
C22	(Same as C21)	54-0289
C23	CAPACITOR, Fixed: electrolytic; 40 mfd; 250 vdcw; Cornell Dubilier Type BR	031-996
CR1	DIODE, Crystal: diffused silicon; 600 PIV; Type 1N2864	57-0012
CR2	(Same as CR1)	57-0012
CR3	RECTIFIER, Selenium: Radio Receptor Part No. C11S1C1E1G	582-998
DS1	LAMP, Neon: miniature; amber; Eldema Part No. 1B9-5277	060-996
F1	FUSE, Cartridge: 0.75 amps; slow-blow; 125 v; 1/4 in. dia. by 1-1/4 in. lg.: Littlefuse Part No. 313.750	070-048
J1S	CONNECTOR, Receptacle: female; 3 contact; Cannon Part No. XLR-3-31	146-998
J2S	(Same as J1S)	146-998
J3S	(Same as J1S)	146-998
J4S	(Same as J1S)	146-998
J5S	(Same as J1S)	146-998
J6S	(Same as J1S)	146-998
J7S	SOCKET, Octal: mica; Cinch-Jones Part No. 12272-8-AM	150-010
J8S	(Same as J7S)	150-010
J9P	CONNECTOR, Receptacle: male; 3 contact; Cannon Part No. XLR-3-32	147-999
J10P	(Same as J9P)	147-999
J11S	CONNECTOR, Receptacle: female; 2 contact; Circle F Part No. M-438	146-999
J12P	CONNECTOR, Receptacle: male; 2 contact; Tower Part No. C10610A	147-032

REF. NO.	PART DESCRIPTION	AMPEX PART NO.
R1	RESISTOR, Fixed: composition; 22K ohms; $\pm 10\%$; 1/2 watt; MIL-R-11A: RC20GF223K	041-064
R2	RESISTOR, Fixed: composition; 1.5K ohms; $\pm 10\%$; 1/2 watt; MIL-R-11A: RC20GF152K	041-050
R3	RESISTOR, Fixed: film; 47K ohms; $\pm 1\%$; 1 watt; Dalohm Type DC-1	042-049
R4	RESISTOR, Fixed: composition; 10K ohms; $\pm 10\%$; 1/2 watt; MIL-R-11A: RC20GF103K	041-060
R5	RESISTOR, Variable: composition; 100K ohms; $\pm 10\%$; 2 watt; Allen Bradley Part No. JA1N056S104AZ	044-015
R6	(Same as R1)	041-064
R7	(Same as R2)	041-050
R8	(Same as R3)	042-049
R9	(Same as R4)	041-060
R10	(Same as R5)	044-015
R11	(Same as R1)	041-064
R12	(Same as R2)	041-050
R13	(Same as R3)	042-049
R14	(Same as R4)	041-060
R15	(Same as R5)	044-015
R16	RESISTOR, Fixed: composition; 1.2 megohms; $\pm 10\%$; 1/2 watt; MIL-R-11A: RC20GF125K	041-084
R17	(Same as R1)	041-064
R18	(Same as R2)	041-050
R19	(Same as R3)	042-049
R20	(Same as R4)	041-060
R21	(Same as R5)	044-015
R22	(Same as R16)	041-084
R23	RESISTOR, Fixed: composition; 330K ohms; $\pm 5\%$; 1/4 watt; Allen Bradley Type CB	041-932
R24	(Same as R23)	041-932
R25	(Same as R23)	041-932
R26	(Same as R23)	041-932
R27	(Same as R23)	041-932
R28	(Same as R23)	041-932
R29	(Same as R23)	041-932
R30	(Same as R23)	041-932
R31	RESISTOR, Fixed: composition; 220K ohms; $\pm 10\%$; 1/2 watt; MIL-R-11A: RC20GF224K	041-076
R32	RESISTOR, Variable: composition; 1 megohm; $\pm 20\%$; .3 watt; Chicago Telephone Type PE-200	044-993
R33	RESISTOR, Fixed: composition; 8.2K ohms; $\pm 10\%$; 1/2 watt; MIL-R-11A: RC20GF822K	041-059
R34	RESISTOR, Fixed: wirewound; 1.5K ohms; $\pm 5\%$; 1 watt; IRC Type BW-1	043-989
R35	(Same as R31)	041-076
R36	(Same as R32)	044-993
R37	(Same as R33)	041-059
R38	(Same as R34)	043-989
R39	RESISTOR, Fixed: composition; 3.9K ohms; $\pm 10\%$; 1 watt; MIL-R-11A: RC32GF392K	041-153
R40	RESISTOR, Fixed: composition; 4.7K ohms; $\pm 10\%$; 1/2 watt; MIL-R-11A: RC20GF472K	041-056
R41	RESISTOR, Fixed: composition; 100K ohms; $\pm 10\%$; 1/2 watt; MIL-R-11A: RC20GF104K	041-072
R42	(Same as R40)	041-056
R43	(Same as R39)	041-153
R44	RESISTOR, Fixed: composition; 2.2K ohms; $\pm 10\%$; 2 watt; MIL-R-11A: RC42GF222K	041-205
R45	RESISTOR, Fixed: composition; 240K ohms; $\pm 5\%$; 1/2 watt; MIL-R-11A: RC20GF244J	041-374
R46	RESISTOR, Fixed: composition; 560K ohms; $\pm 10\%$; 1/2 watt; MIL-R-11A: RC20GF564K	041-081

REF. NO.	PART DESCRIPTION	AMPEX PART NO.
R47	RESISTOR, Fixed: composition; 22K ohms; ±10%; 2 watt; MIL-R-11A: RC42GF223K	041-216
R48	RESISTOR, Fixed: composition; 150K ohms; ±10%; 1/2 watt; MIL-R-11A: RC20GF154K	041-074
R49	(Same as R45)	041-374
R50	(Same as R46)	041-081
R51	(Same as R47)	041-216
R52	(Same as R48)	041-074
R53	POTENTIOMETER, Dual: ganged; 25K ohms	96928-01
R54	RESISTOR, Fixed: composition; 24K ohms; ±5%; 1/2 watt; MIL-R-11A: RC20GF243J	041-369
R55	(Same as R54)	041-369
R56	RESISTOR, Fixed: wirewound; 2 ohms; ±10%; 5 watt; Tru-Ohm Type X-60	043-990
R57	RESISTOR, Fixed: composition; 2.2K ohms; ±10%; 1/2 watt; MIL-R-11A: RC20GF222K	041-052
R58	(Same as R57)	041-052
S1	SWITCH, Mixer	96925-01
S2	(Same as S1)	96925-01
S3	SWITCH, Mixer	96926-01
S4	(Same as S3)	96926-01
S5	(Same as S3)	96926-01
S6	(Same as S3)	96926-01
S7	SWITCH, Slide: DPDT	96139-02
S8	SWITCH, Toggle: SPST; paddle handle; 3 amp; Circle F Part No. 1887-L4P	120-999
T1	TRANSFORMER, Microphone	96908-01
T2	(Same as T1)	96908-01
T3	(Same as T1)	96908-01
T4	(Same as T1)	96908-01
T5	TRANSFORMER, Power	96144-01
TS1	STRIP, Terminal: barrier; 6 terminals; Cinch- Jones Part No. 6-140Y	180-111
V1	TUBE, Electron: 9 pin; miniature; Amperex Type EF86/6267	012-098
V2	(Same as V1)	012-098
V3	(Same as V1)	012-098
V4	(Same as V1)	012-098
V5	(Same as V1)	012-098
V6	(Same as V1)	012-098
V7	TUBE, Electron: 9 pin; miniature; Amperex Type 12AU7	012-107
	INDICATOR, Reset	50735-02
	PLUG ASSEMBLY, Dummy	17420-01
	KNOB, Key tab (MX-10)	96922-01
	KNOB, Key tab (MX-35)	96922-02
	CORD, Power Input	084-004
	POST, Fuse: Littelfuse Part No. 342012	085-001
	SHIELD, Tube: 9 pin; Cinch-Jones Part No. 9S2	160-012
	KNOB, Medium dark grey (MX-10)	96585-01
	KNOB, Black (MX-35)	230-003
	KNOB, Light grey (MX-10)	96585-02
	KNOB, Black (MX-35)	230-004
	SOCKET, Tube: 9 pin; Cinch-Jones Part No. 53F12621	150-020
	CONNECTOR, Plug: female; 3 contact; Cannon Part No. XL-3-11	144-003

PARTS LOCATION
 MX-10 MIXER
 Catalog No. 96900-01

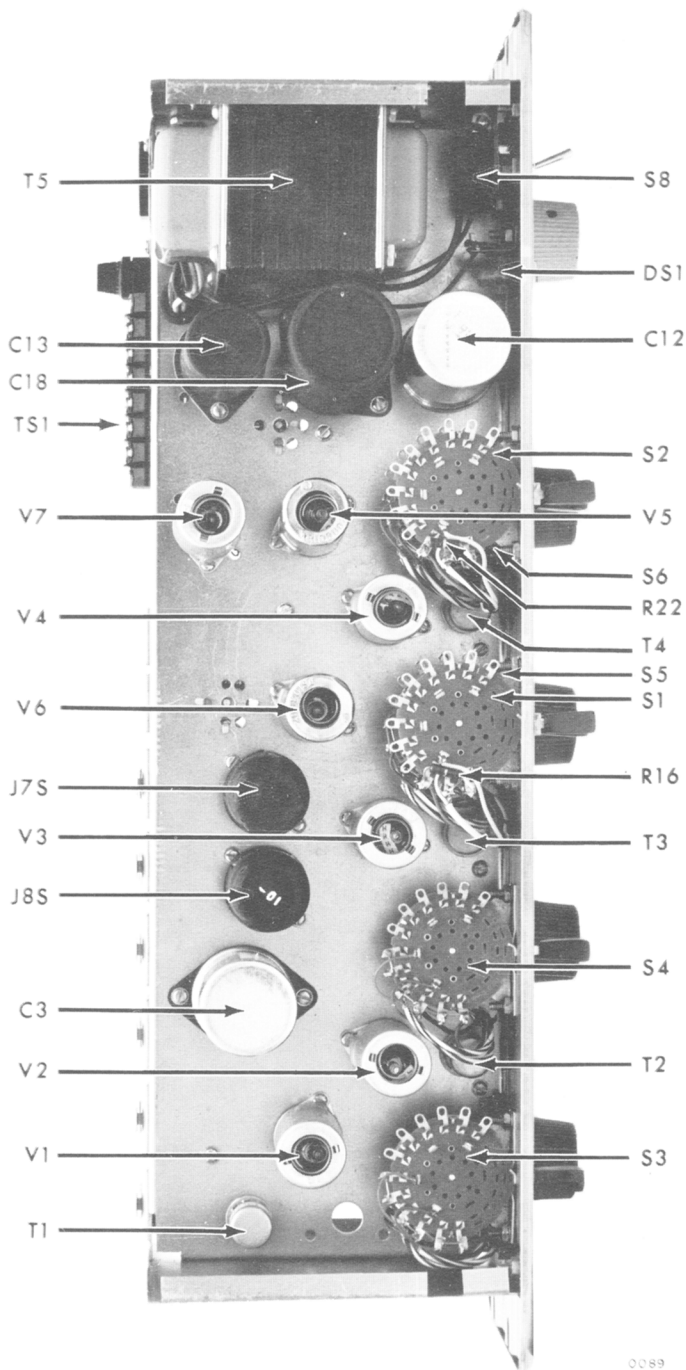

0089

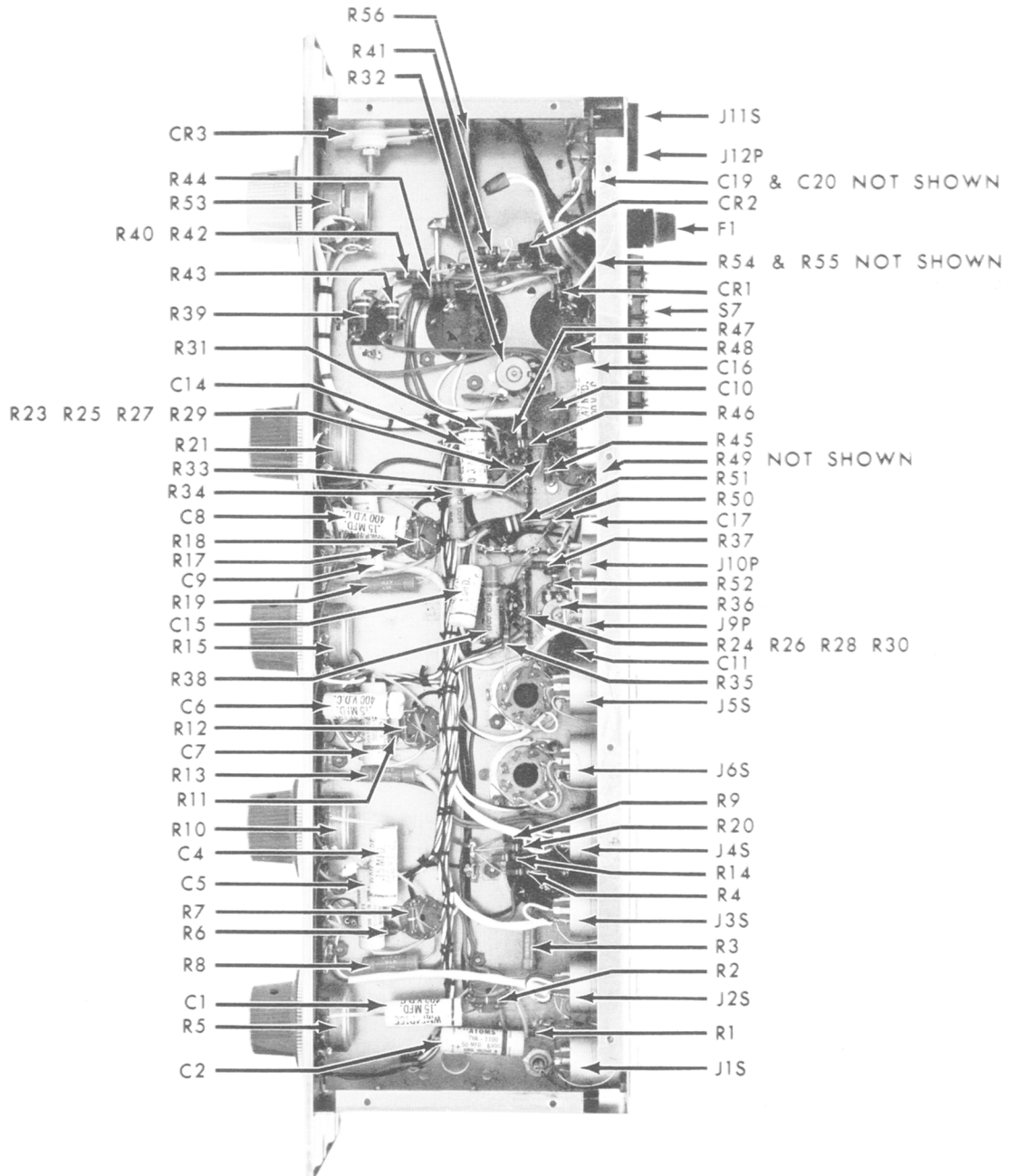

PARTS LOCATION
MX-35 MIXER

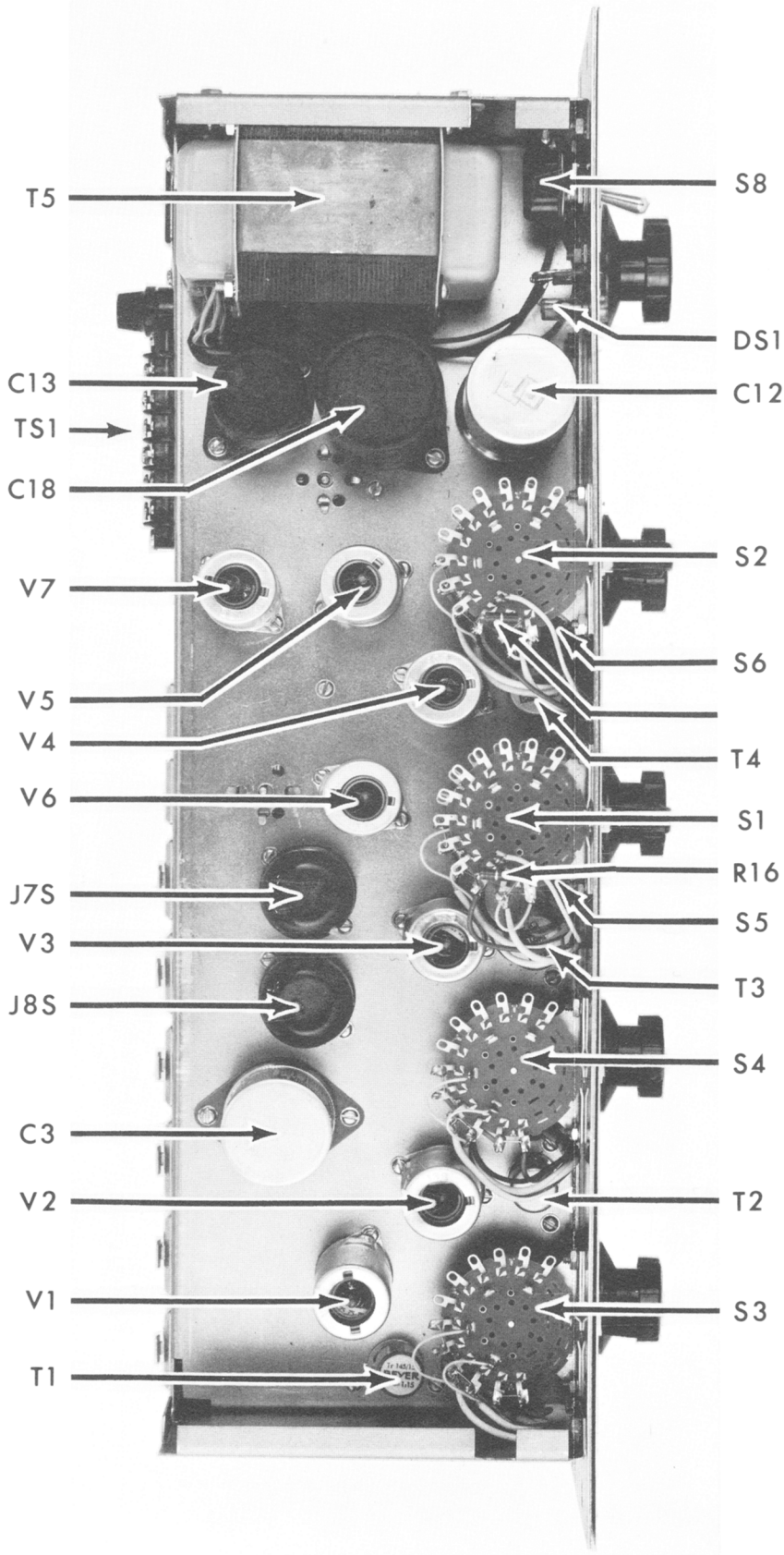

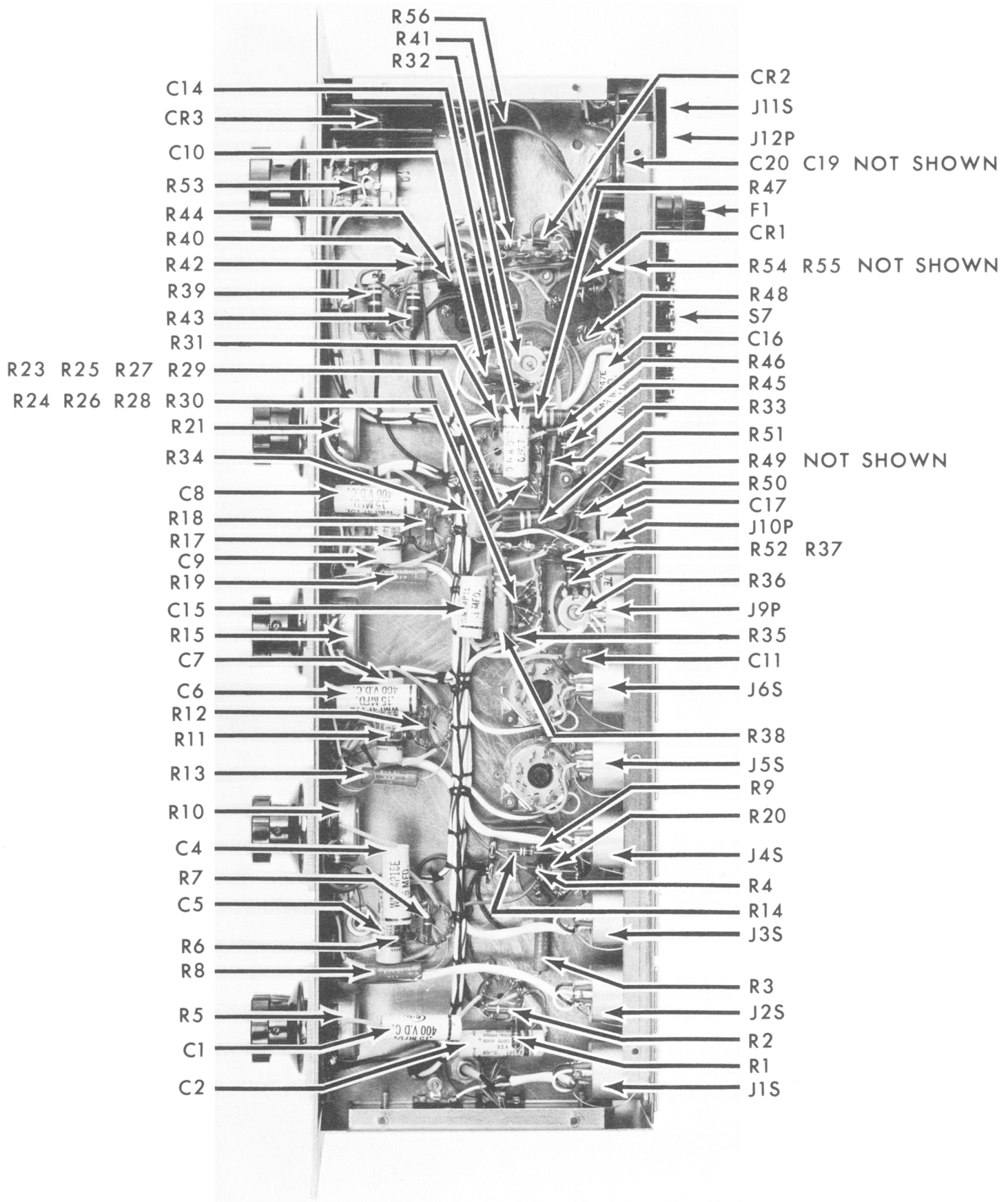

Section 7 THEORY OF OPERATION

Section 7 THEORY OF OPERATION

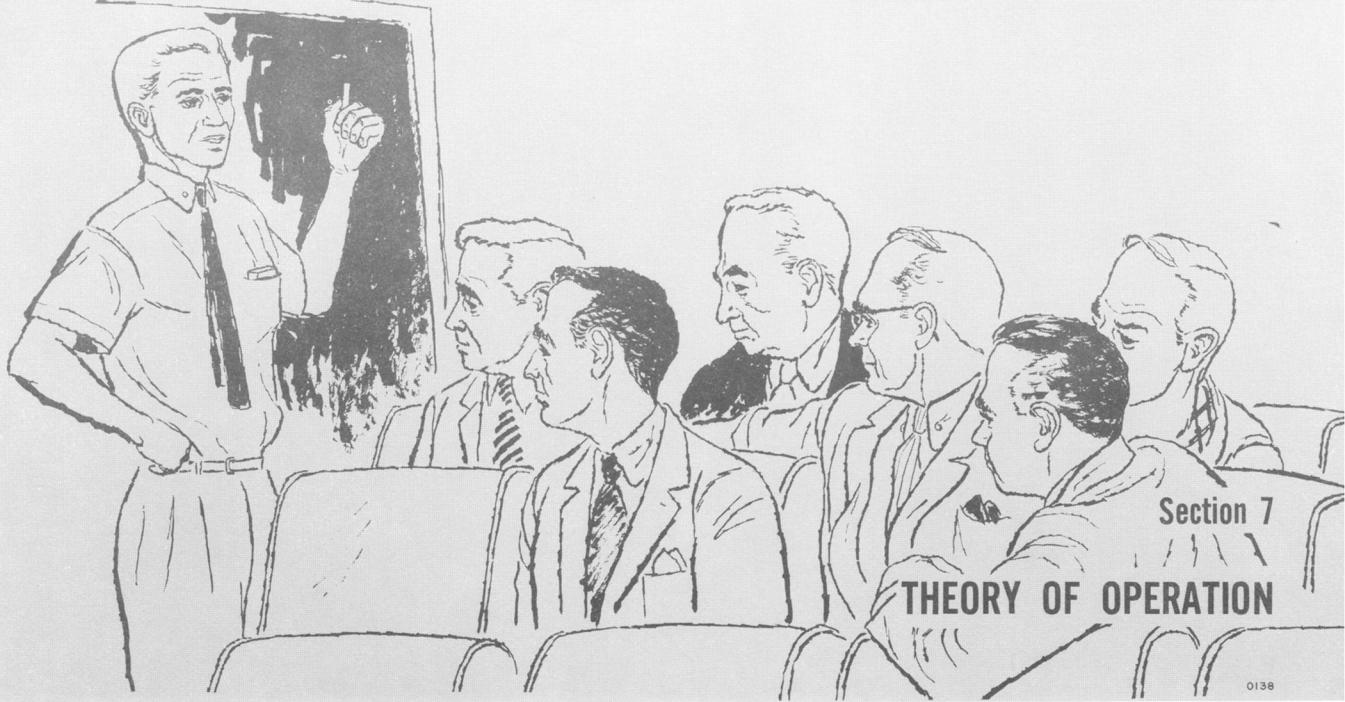

MICROPHONE PREAMPLIFIERS

Operation of the four microphone preamplifiers is identical. Each preamplifier is a high-gain low-noise, triode-connected pentode. The audio signal from a low impedance microphone is fed to the control grid of the preamplifier by the input transformer. The audio signal is amplified by the preamplifier and coupled to the gain control. In the case of a microphone/line input, switching between the microphone input and the line input takes place immediately prior to the gain control.

From the gain control, the signal is coupled to the channel selector switch for the station

concerned. The channel selector is a three-position switch that connects the signal to either or both output amplifiers while maintaining correct loading and attenuation relationships.

Resistors R1, R6, R11 and R17 are used to isolate the tube input capacitance from the inductance of the secondary winding of the input transformer to yield a flat frequency response.

OUTPUT AMPLIFIERS

The output amplifier consists of a pentode amplifier followed by a cathode follower. One

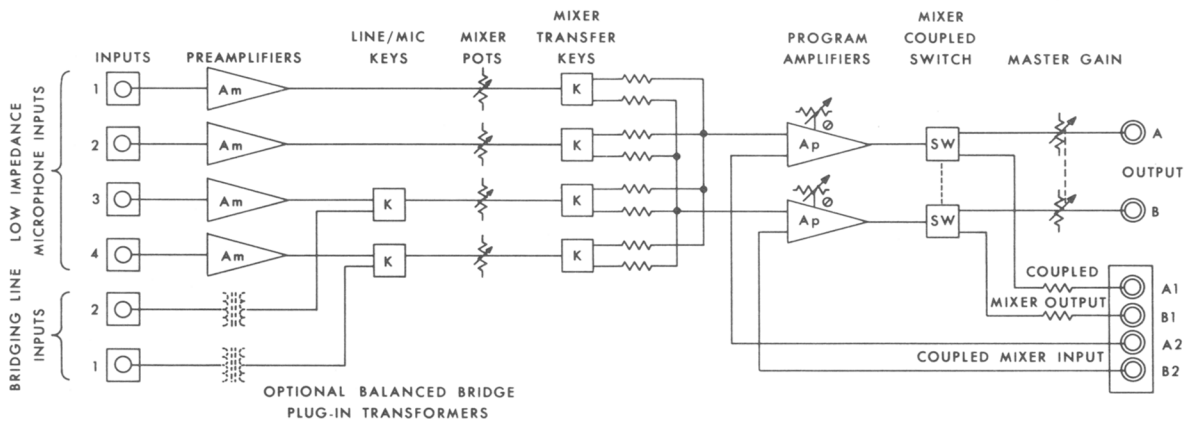

Block diagram, MX-10 mixer

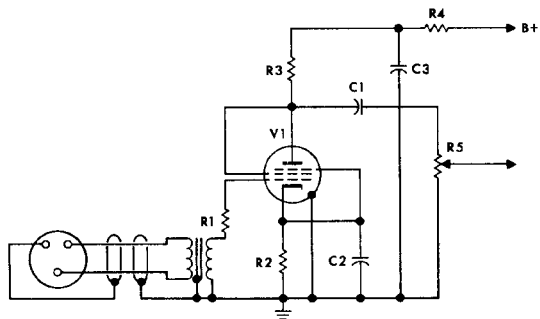

0084

Partial schematic diagram,
microphone preamplifier

of the unusual portions of the circuit is the source of the screen grid voltage for the pentode stage which is derived from the cathode of the follower stage. This provides added reliability to the circuit and helps compensate for tube aging. The plate of the pentode stage is directly coupled to the control grid of the cathode follower.

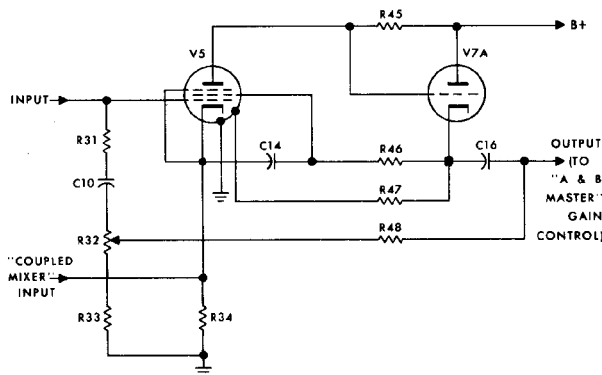

0085

Partial schematic diagram,
output amplifier

The cathode resistor of the cathode follower is interlocked to ground through the two shield connections of the pentode stage so that excessive current will not be drawn by the cathode follower when the pentode is pulled from the tube socket.

Negative feedback is applied from the cathode of the cathode follower to the control grid of the pentode stage through output capacitor

C16 (C17 for channel "B"), resistor R48 (R52 for channel "B"), LEVEL SET potentiometer R32 (R36 for channel "B"), capacitor C10 (C11 for channel "B"), and resistor R31 (R35 for channel "B"). The negative feedback provides overall gain stability to the circuit and the LEVEL SET potentiometers control the overall gain of each channel of the mixer assembly.

MIXER COUPLING

When switch S7 is in the SINGLE MIXER NORMAL position, the output of the cathode follower is fed to the output connector through the A & B MASTER gain control, R53. When switch S7 is in the MIXER COUPLE position, the output of the cathode follower is connected to terminal strip TS1 through attenuator resistor R54 (R55 for channel "B") and when the terminal strip is connected to terminal strip TS1 of a second mixer assembly, the signal from the first mixer is attenuated and combined with the signal from the second mixer.

POWER SUPPLY

Silicon rectifiers CR1 and CR2 are used in a conventional full-wave voltage doubler rectifier circuit to supply plate power for all tubes in the mixer assembly. Selenium rectifier CR3 is connected as a conventional full-wave center tap rectifier to provide dc filament voltage to all tubes.

The center tap of the V7 tube filament provides a ground for the dc filaments. AC power input is connected at the power receptacle, J12P, and is controlled by POWER switch S8. The power is fed through fuse F1 to the primary of power transformer T5.

There are two secondary windings on the power transformer—one for the filament supply and one for the high voltage supply. The filament winding supplies 12.6 volts dc (after rectification), to the filaments of all tubes. The high voltage supply ripple is filtered by a capacitance-input r-c filter formed by resistors R39, R40, R42, R43, and R44 and capacitors C13, C12d, C12c, C12b, and C12a; additional filtering is supplied by the decoupling networks.

SCHEMATIC DIAGRAM

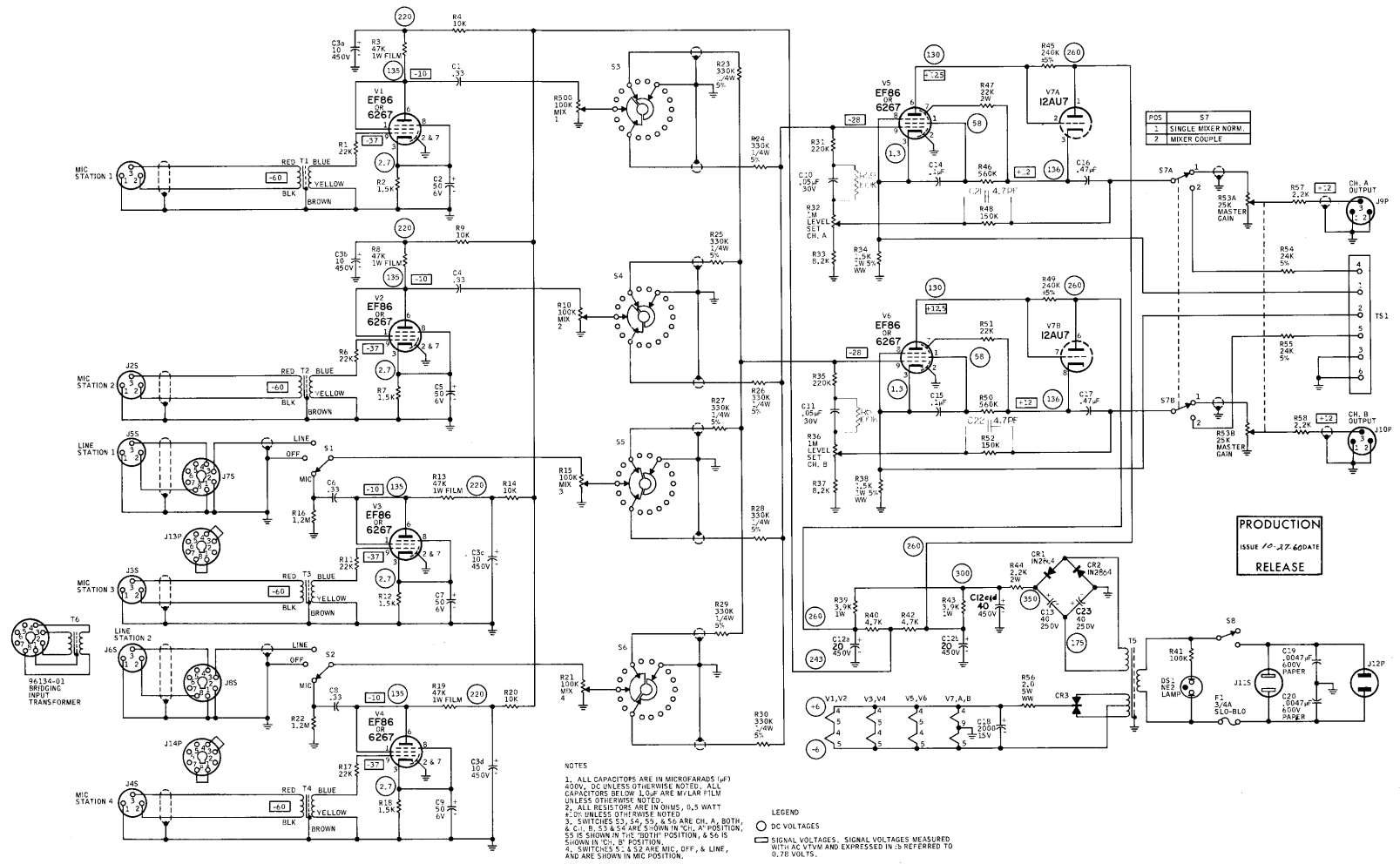

NOTES

1. ALL CAPACITORS ARE IN MICROFARADS (μF) 250V, DC UNLESS OTHERWISE NOTED. ALL CAPACITORS BELOW 1.0μF ARE M/LAR FILM UNLESS OTHERWISE NOTED.
2. ALL RESISTORS ARE IN OHMS, 0.5 WATT
3. UNLESS OTHERWISE NOTED
4. SWITCHES S1, S4, S5, & S6 ARE CH. A, BOTH 2, C, & S2 ARE S-DOWN IN MIC. S POSITION, S5 IS SHOWN IN "BOTH" POSITION, & S6 IS SHOWN IN "C, B" POSITION
5. SWITCHES S1 & S2 ARE MIC, OFF, & LINE, AND ARE SHOWN IN MIC POSITION.

LEGEND

○ DC VOLTAGES

◻ SIGNAL VOLTAGES. SIGNAL VOLTAGES MEASURED WITH AC VTVM AND EXPRESSED IN -dB REFERRED TO 0.70 VOLTS.

Section 8 NOTES AND BULLETINS

NOTES AND BULLETINS

Section 8

NOTE

As stated in the introduction, Ampex publishes service bulletins and operation bulletins from time to time. To be placed on the mailing list for these valuable bulletins, it is only necessary to mail the Warranty Registration card included with the equipment.

Section 9 **INDEX**

Section 9 **INDEX**

INDEX

Accessories	
Description of	2-2
Installation of	3-1
Adjustment	
Gain	5-2
Application	
Dubbing	2-3
Multichannel	2-3
Single-channel	2-3
Two-channel	2-3
Connections	
Multichannel	3-3
Multiple inputs	3-3
Single- and two-channel	3-3
Diagrams	
Interconnection	3-2
Measurement set-up	5-1
Mixer schematic	7-3
Output amplifier schematic	7-2
Parts location	6-9
Preamplifier schematic	7-2
System block	7-1
Troubleshooting block	6-1
Dimensions	
General	2-2
Mounting	3-2
Distortion specification	2-2
Frequency Response	
Measurement of	5-2
Specification	2-2
Gain	
Adjustment of	5-2
Measurement of	5-1
Specification	2-2
Instruction manual, use of	1-1
Measurement	
Frequency response	5-2
Gain	5-1
Noise specification	2-2

INDEX

Operation	
Overall	4-1
Theory of	7-1
Ordering parts	6-1
Output amplifier	
Schematic diagram	7-2
Theory of operation	7-1
Parts	
List of	6-3
Location	6-9
Ordering of	6-1
Preamplifier	
Schematic diagram	7-2
Theory of operation	7-1
Power requirements	2-2
Power supply theory	7-2
Switching	
Description	2-1
Function	4-1
Use	4-2
Theory of operation	
Mixer coupling	7-2
Output amplifier	7-1
Power supply	7-2
Preamplifier	7-1