

# Schematic Diagram, SA-10 Amplifier Assembly

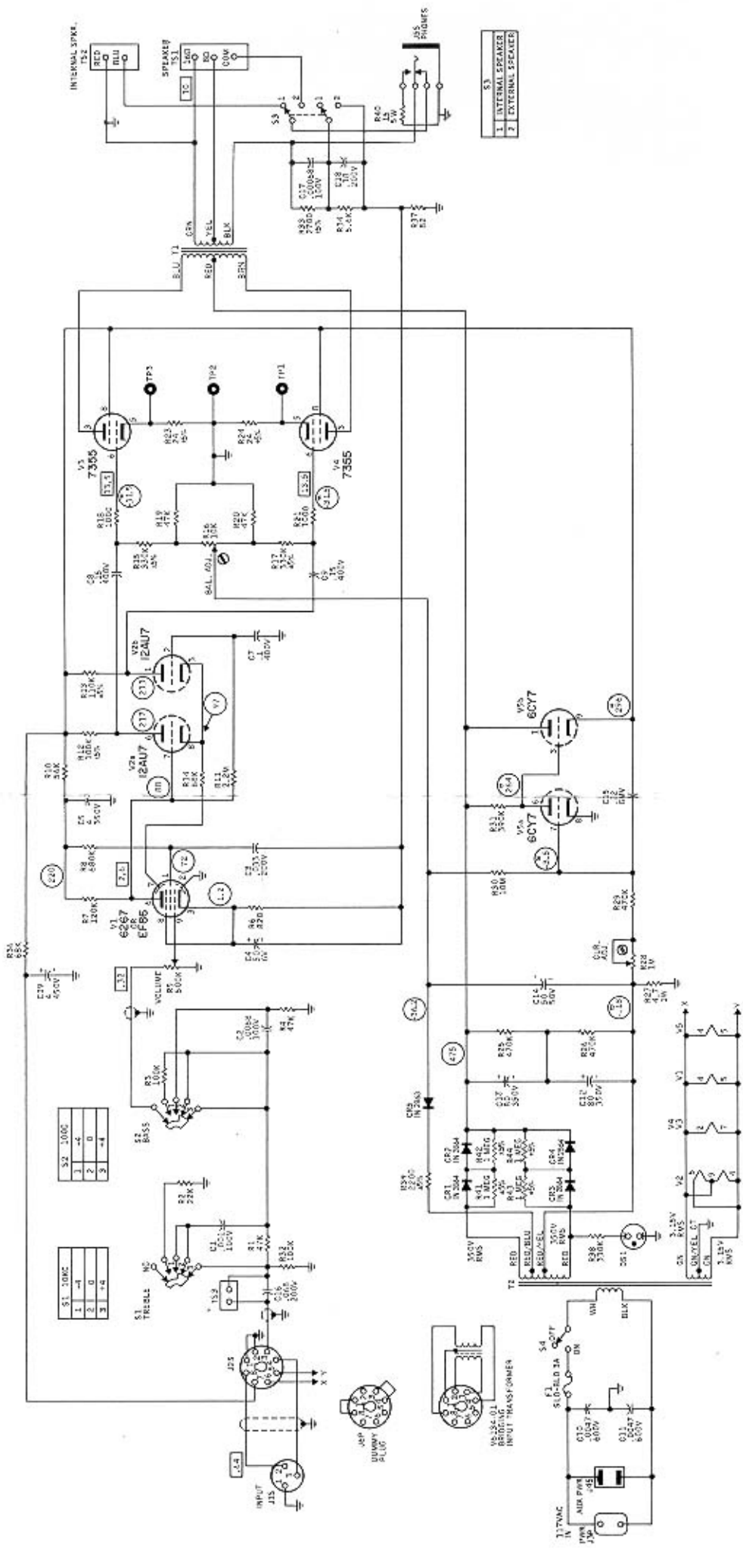

1	INTERNAL SPEAKER
2	EXTERNAL SPEAKER

S1	TREBLE	1	0
		2	1
		3	2
		4	3

S2	BASS	1	0
		2	1
		3	2
		4	3

**NOTES:**

- ALL RESISTOR VALUES ARE IN OHMS UNLESS OTHERWISE SPECIFIED.
- RESISTOR VALUES ARE IN PERCENTAGE.
- DC VOLTAGES MEASURED WITH SIGNAL APPROXIMATELY 100-MV RMS INPUT RESISTANCE AND 100-HZ INPUT FREQUENCY.
- VOLTAGES MEASURED WITH AC VTVM AND EXPRESSED IN RMS VOLTS.
- OPERATION WITH S1, S2, & S3 IN POSITION 1.

**LEGEND:**

- ⊕ APPROXIMATE DC VOLTAGES
- ⊙ DC VOLTAGES
- ⊖ SIGNAL VOLTAGES: 50-CYCLE SIGNAL
- ⊘ VOLTAGES MEASURED WITH AC VTVM AND EXPRESSED IN RMS VOLTS.

**IMPORTANT:**

FOR FLAT LOW-FREQUENCY RESPONSE WHEN USING EXTERNAL SPEAKER OR STRAP ADDRESS, INPUT TERMINAL Q17, 3.

FLAT

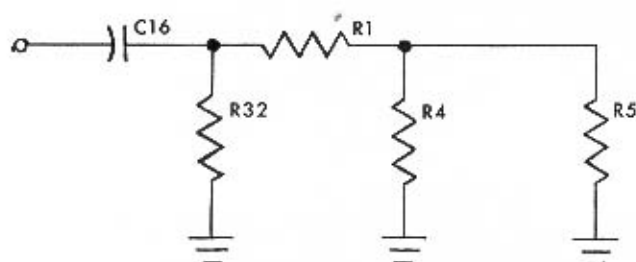

TREBLE CUT (BASS FLAT)

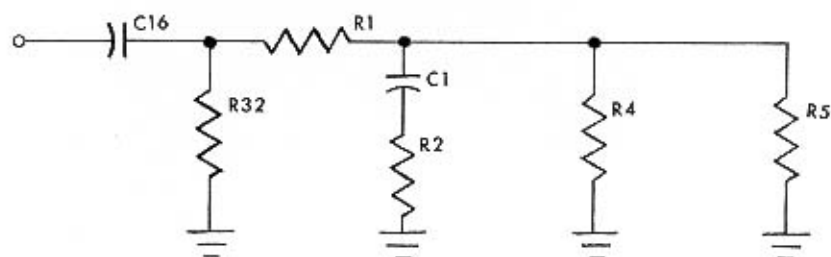

TREBLE BOOST (BASS FLAT)

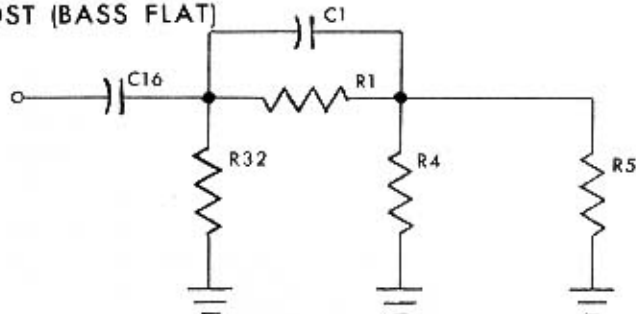

BASS CUT (TREBLE FLAT)

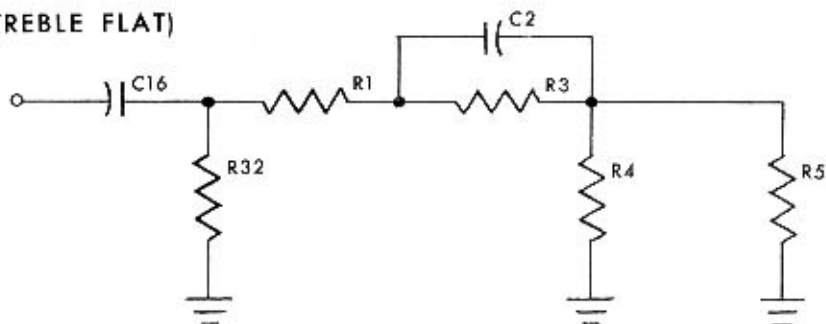

BASS BOOST (TREBLE FLAT)

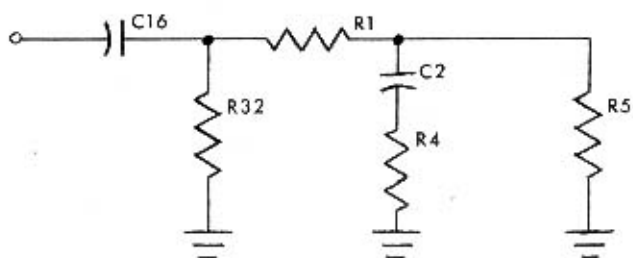

018

*Tone Switching Combinations*



## AMPLIFIER CIRCUITS

The signal to be amplified enters the unit at J1 across pins 2 and 3 (pin 1 is ground). Under unbalanced line operation the dummy plug at J2 jumpers the input at pin 2 to ground, and the input at pin 3 to the high side of the signal circuit. Under balanced line conditions the plug-in input transformer at J2 connects the signal at pins 2 and 3 across the primary of the transformer; one end of the secondary winding is grounded while the other is connected to the high side of the signal circuit. In the latter case the shield of the input cable is connected to pin 1 of J1. When the equipment is to be used directly with a microphone, the primary of the plug-in input transformer at J2 is connected across pins 2 and 3 of the input connector. (See schematic diagram, microphone preamp).

The signal next encounters the tone control circuits. Each tone control switch (S1 for 10 kc, S2 for 100 cps) has three positions — +4 db, 0, and -4 db — which corresponds to a frequency response boost, a flat response, or a frequency response attenuation respectively. In the following discussion remember that

these are relative terms, for example boosting the high frequencies means that their strength is increased in relation to other frequencies.

When both switches are in the 0 (flat) position, R1 and R4 constitute a 6 db attenuating circuit for all frequencies. Tone control is achieved by switching other components in and out of the circuit. It is easier to understand the principles of this circuit if we consider one switch at a time and assume that the other switch is in the 0 position (designated 2 on the schematic diagram).

Starting with the 10 kc, switch, S1: When it is in +4 db position, (designated 3 on the schematic diagram) the 6 db attenuation network of R1 and R4 is still in the circuit for low frequencies. For high frequencies, however, capacitor C1 now bypasses R1, so normal high frequency attenuation is reduced. When S1 is placed in -4 db position (designated 1 on the schematic diagram) R1 and R4 still affect the normal attenuation of low frequencies. C1, however, now affords high frequencies a path to ground in parallel with R4, and those frequencies are reduced in strength. If C1 were in the

circuit by itself, its impedance would progressively decrease as the frequency increased, and we would have a continuous "roll off" condition. To prevent this, and provide a -6 db high frequency shelf, R2 is placed in series with C1 to ground so that the impedance of the C1-R2 circuit never drops below the value of R2. Thus at 10 kc and above, all frequencies are attenuated by an equal amount with no roll off.

Now for the 100 cps switch: In the +4 db position, C2 is in series with the R1-R4 normal circuit. This capacitor has little effect at high frequencies, so they are practically attenuated by the normal 6 db. However, C2 adds a quite considerable impedance at low frequencies, increasing the shunt path to ground and decreasing the normal attenuation. In the -4 db position, all frequencies must proceed through C2 adding considerable impedance in the low frequency path and increasing the normal attenuation. If C2 were alone in the circuit, its impedance would increase as frequency decreased, and we would have a continuous roll off condition at low frequencies. Resistor R3 is therefore paralleled with C2 to provide a limit to the total impedance. A -6 db shelf thus takes place below approximately 100 cycles.

After passing the tone control circuits, the signal is impressed on the grid of V1 through VOLUME control R5. This is a conventional audio amplifier circuit, with C5 and R10 acting as a decoupling network. Negative feedback is obtained by returning voltage from the secondary of the output transformer back to the cathode of the first voltage amplifier stage. The signal is directly coupled from the plate of V1 to one control grid of V2.

One half of V2 acts as a conventional audio amplifier, with the other half providing a differential (grounded grid) phase inversion circuit. Note that the two cathodes are tied together, with R14 as a common unbypassed cathode resistor, connected to ground through the internal shield connections of V1 (to prevent damage of V2 if V1 is removed). When the directly coupled signal is impressed on the grid of V2a, the potential at *both* cathodes will vary as a function of the signal voltage. Insofar as the signal is concerned, the grid of the phase inverter stage is grounded through C7. (R11 establishes the same dc voltage on the grid of V2b as that on the grid of V2a.) Thus in this

type of phase inverter circuit the cathode potential varies with the signal, while the grid potential remains constant. The two signals, 180° out of phase, from V2 are coupled to the grids of the push-pull output stage V3-V4.

Fixed bias on V3 and V4 is derived from the voltage divider circuit comprised of potentiometer R16 and resistors R19 and R20. Control R16 adjusts the balance on the two tubes to achieve equal cathode currents, which can be measured across TP1-TP2 and TP3-TP2. Resistors R18 and R21 act as parasitic suppressors. The push-pull tubes operate class B, to achieve relatively high efficiency as compared to class A operation.

The plates of V3 and V4 are connected in push-pull to the primary of output transformer T1. The high side of the secondary is connected directly to terminal strips which feed the internal or external loudspeaker assembly. Connected across this line to ground is an output network consisting of R33, R34, R37, C17 and C18. Of these components, R34 and C18 form the enclosure compensation circuit for the internal speaker; it is shorted out by one pole of S3 when that switch is in the external speaker position. The other components in this network supply frequency stabilization and negative feedback.

The ground side of the output line proceeds through the contacts of phone jack J5 and the second pole of S3 (which selects the speaker circuit that will be completed to ground). Note that inserting a headset plug into J5 will disconnect the output to both terminal strips, with resistor R40 providing proper termination.

#### CAUTION

*Never connect head sets to J5 without first turning volume control R5 full counterclockwise. This control can then be re-adjusted to a comfortable listening level, but the available output level of the amplifier can easily damage some headsets.*

#### POWER SUPPLY CIRCUIT

The power line is connected at J3, with capacitors C10 and C11 supplying r-f filtering. Convenience outlet J4 is provided preceding



the overload fuse F1. The a-c power is then connected, through power ON-OFF switch S4, across the primary of power transformer T2.

There are two secondary windings on T2, one high voltage and one low voltage. The latter provides a-c heater power to all tubes in the assembly, and to the Nuvistor in the optional plug-in preamplifier.

Rectifiers CR1, CR2, CR3, and CR4 are connected in a conventional full-wave center-tap rectifier circuit. Ripple filtering is provided by C12 and C13, with R25 and R26 ensuring an equal voltage distribution across these two capacitors. Half-wave rectification and filtering is supplied by CR5 and C14 to provide a negative bias voltage.

Voltage regulation is achieved by an unusual circuit which employs a current sampling procedure to effect compensation for changing conditions. Perhaps a general discussion of the engineering objectives of this circuit will aid in understanding its operation. As the power output of the amplifier increases from zero output to full output, push-pull tubes V3 and V4 (operating class B<sub>1</sub>) will draw more and more plate and screen-grid current causing the plate supply voltage to decrease. If we either connect the screens to the plate supply or still worse used the usual fixed screen grid resistor, this increased current flow would result in decreasing the screen voltage. In turn, the lower screen grid voltage would cause the operation of these tubes to move from class B<sub>1</sub> further and further into class C with the result of clipping the center section out of the waveform. But if a screen resistor that could be made to decrease automatically as current increased (and vice versa) were used between the plate supply and the screen grid circuit, the screen voltage, hence the class of operation, could be maintained throughout the power output range. This type of regulator would also allow the maintenance of the designed class of operation under circumstances where voltage fluctuations occurred in the power line supplying the equipment if it also adjusted the screen voltage as a function of the bias voltage on the control grids of V3 and V4. Actually, the regulated line also supplies the high voltage to tubes V1 and V2; and to the plug-in microphone preamplifier when it is used. This is done primarily to take advantage of the filter-

ing action of the regulator and thus avoid heavy and intricate filters in the power supply.

With this understanding of the basic objectives, the operation of the circuit can best be explained by first pointing out the major components. Stage V5b is the series regulator, the variable resistance mentioned in the preceding paragraph. This stage is similar to a cathode follower, connected in series between the regulated bus and the high voltage line. Stage V5a is the shunt regulator which sets the operating conditions of V5b. Resistor R27 is the current sampling resistor which controls the operation of the regulator. Under no signal conditions, the current through R27 is very small and establishes only a slight negative potential at the center top of the power transformer.

The current through R27 increases as the amplifier tubes conduct more heavily with signal applied, since the total dc current of the amplifier flows through R27. This current flow establishes the potential at the center tap of the power transformer (T2) which will of course, be more negative with respect to ground than during the no signal condition. The potential will vary as the total current in the amplifying tubes varies — becoming more negative as current increases, less negative as current decreases.

Resistors R30, R29, and R28 are connected in a voltage divider circuit from the negative bias bus to the center tap of the power transformer, with the control grid of V5a connected at the junction of R30 and R29. Resistor R28 is adjusted to establish the initial negative bias on the grid of V5a. As the voltage drop changes with signal load, the bias on V5a will change — going more negative as the center tap potential goes negative, and less negative as the center tap potential goes less negative. Thus the voltage at the plate of V5a will vary inversely as a function of the current through R27.

The plate of V5a is directly coupled to the control grid of V5b, and the plate-to-cathode resistance of V5b will therefore vary inversely as a function of the current through R27 — decreasing as the current through R27 increases and increasing as the current through R27 decreases. The objective of maintaining a constant voltage despite variations in current is

thus achieved. Capacitor C15 furnishes a negative feedback arrangement, from the cathode of V5b to the grid of V5a, which acts to remove any ripple component that might be present in the regulated line.

There are two main advantages to this voltage regulator. First, it reliably maintains

the operation of the push-pull output stage in class B, despite widely varying conditions of power line voltage and output level. Second, the amplifier draws more power from the power line only when required to deliver more power to the load — for example, at zero signal input it draws only 50 watts, when delivering full rated power it draws 116 watts.

---