

15.0 Schematics

15.1 Advisory

The diagrams included in this manual are intended principally as a resource for competent maintenance personnel. Many of the circuits are patented and are therefore protected under patent laws. Apex Systems reserves all patent rights. It shall not be construed that publishing of schematics in this manual grants or implies permission for use in any way.

All schematic diagrams included in this manual are believed to be essentially accurate, although they may not reflect the running upgrades and modifications that have occurred since they were drawn. The Model 2020 unit shipped with this manual may contain updates not shown by schematics of the manual. It is our belief that any such variances will be obvious to trained maintenance personnel upon examination, and that such variances will cause little difficulty in the successful repair of the unit.

It is not our intention to provide assistance to entrepreneurs who may want to experiment with or modify the product in any way. The schematics are not warranted for any such use. All liability rests with the entrepreneur in such as case.

15.2 The Schematics →

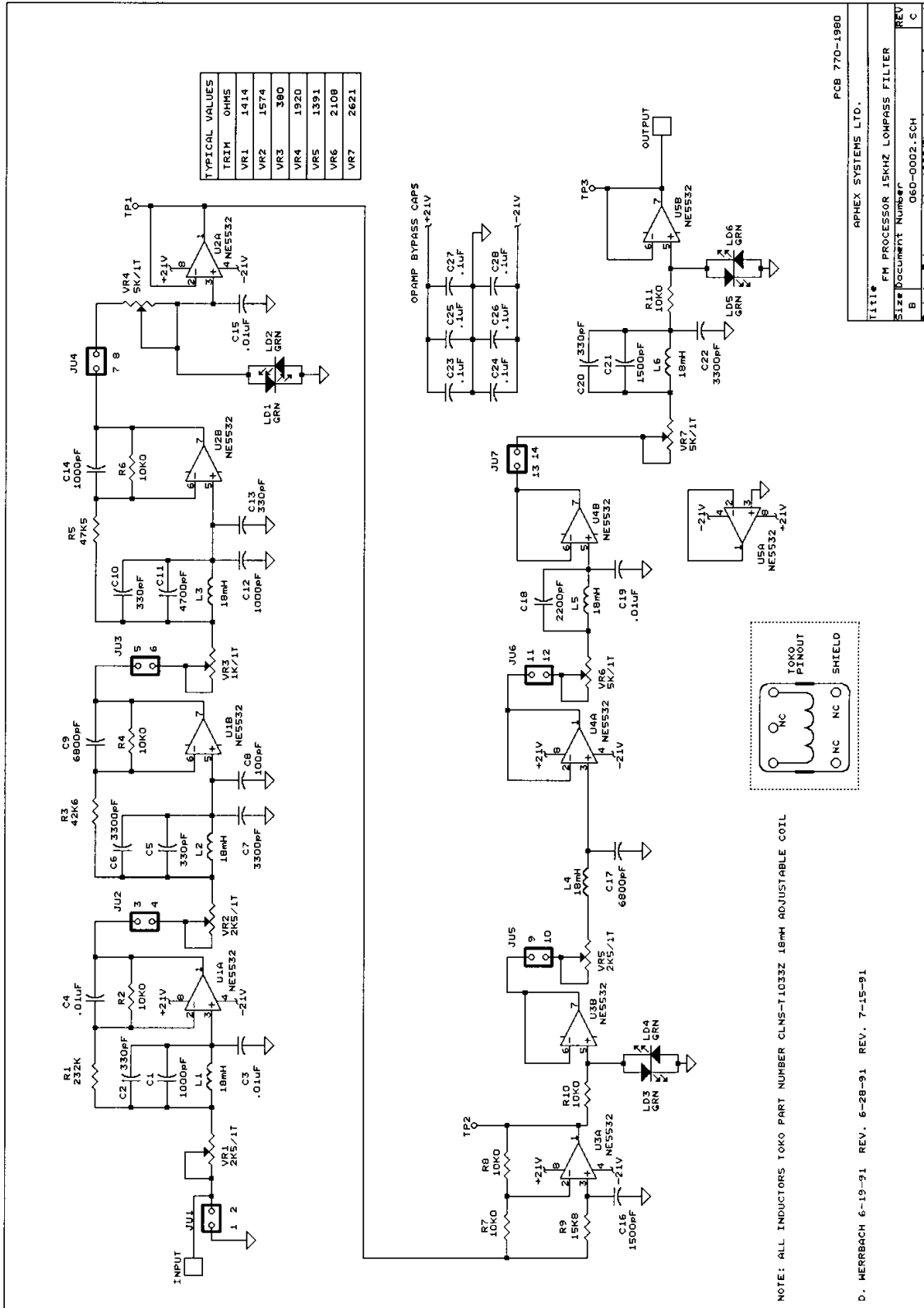

NOTE: ALL INDUCTORS TOKO PART NUMBER CLMS-T1033Z 18MH ADJUSTABLE COIL

D. WERRBACH 6-19-91 REV. 6-28-91 REV. 7-15-91

PCB 770-1980
 APHEX SYSTEMS LTD.
 Title: FM PROCESSOR 15MHZ LOWPASS FILTER
 Size: Document Number: 060-0002-SCH
 Date: FEBRUARY 11, 1998
 REV C 1 of 1

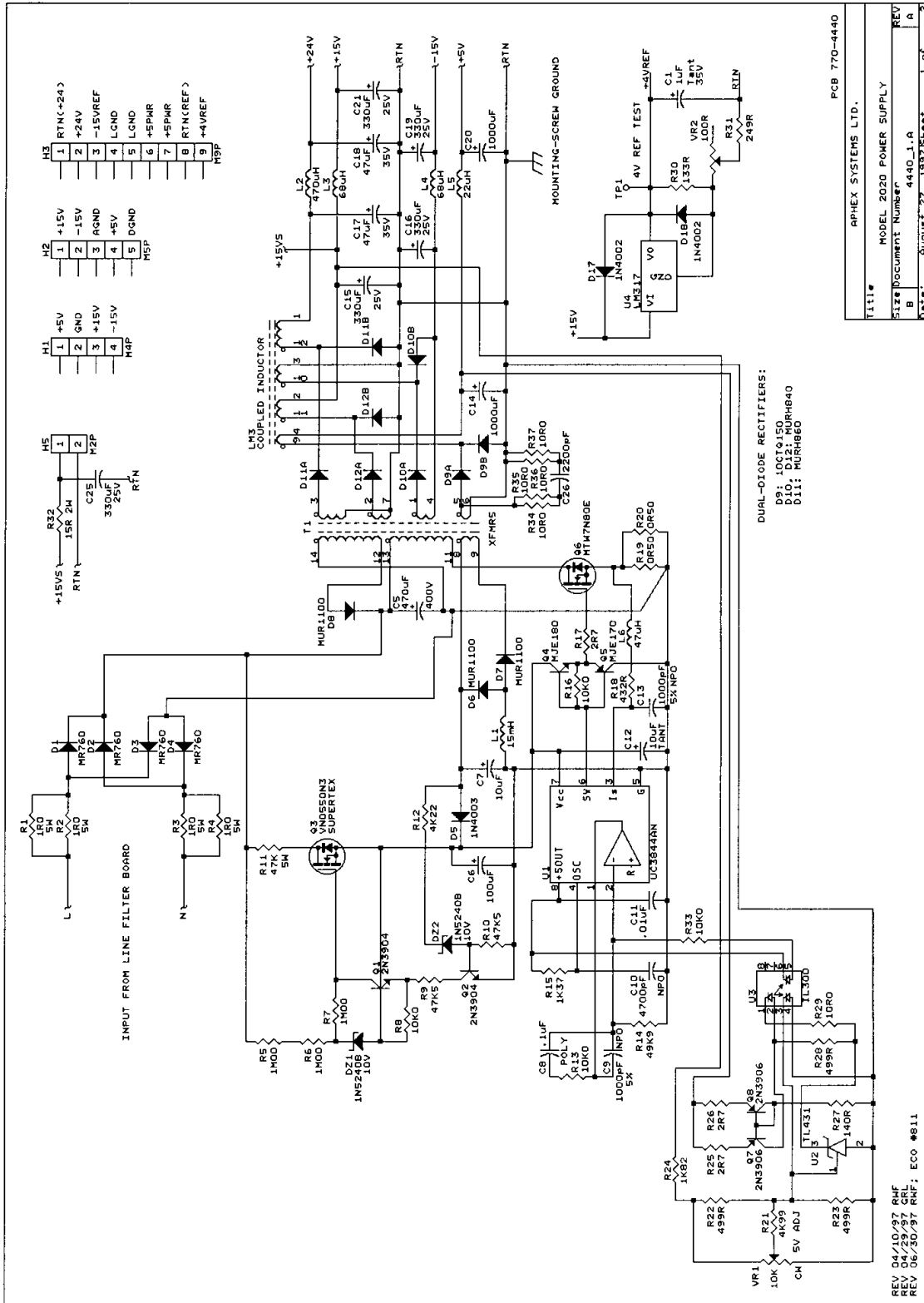

Title		APHEX SYSTEMS LTD.	
Model		MODEL 2020 POWER SUPPLY	
Size		4440_1.A	
Sheet		1 of 2	
Date		August 27, 1987	

DUAL-DIODE RECTIFIERS:
 D9: 10CT0150
 D10: D12: MURH840
 D11: MURH860

REV 04/10/97 RHF
 REV 04/29/97 GRL
 REV 08/30/97 RHF, ECO #811

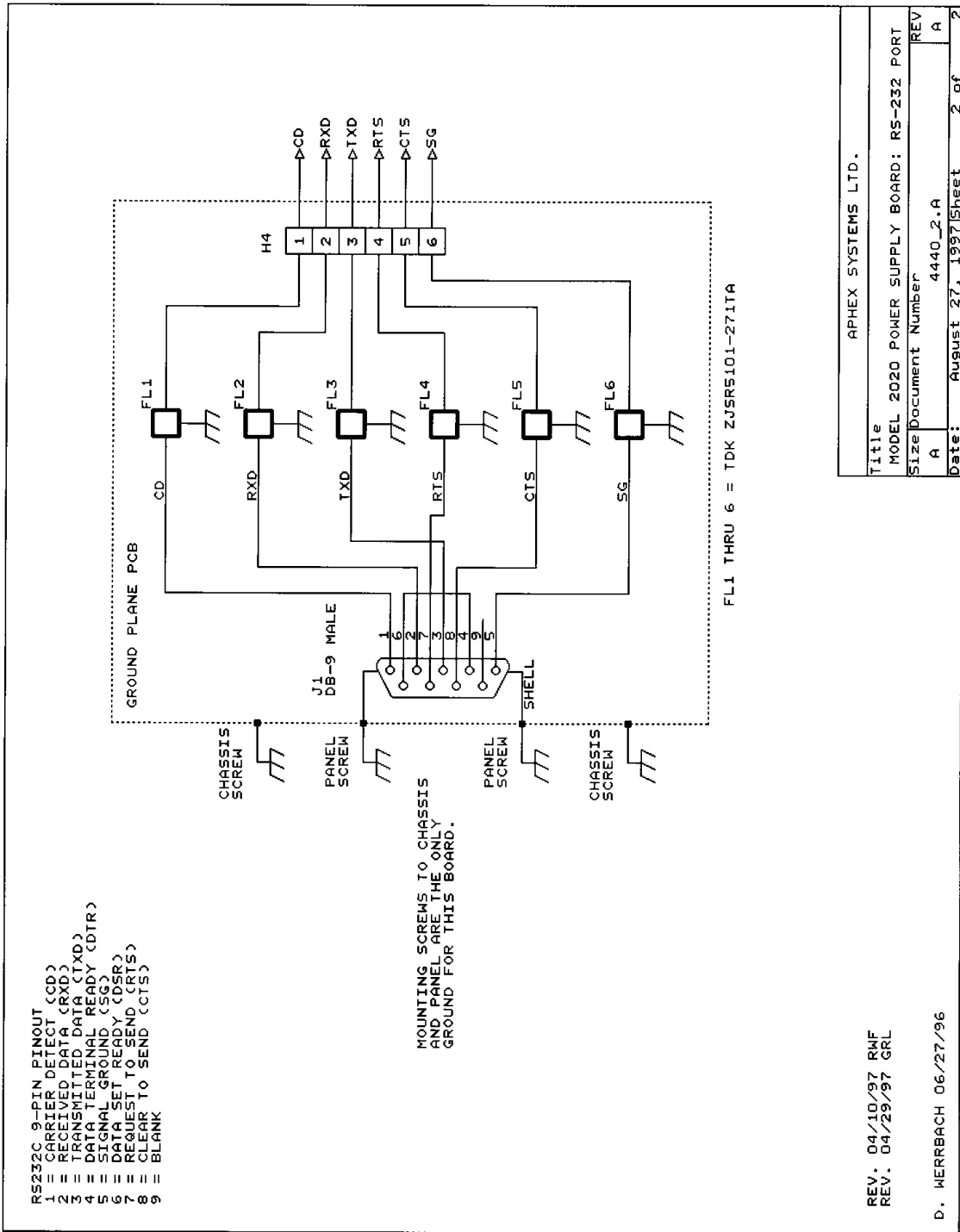

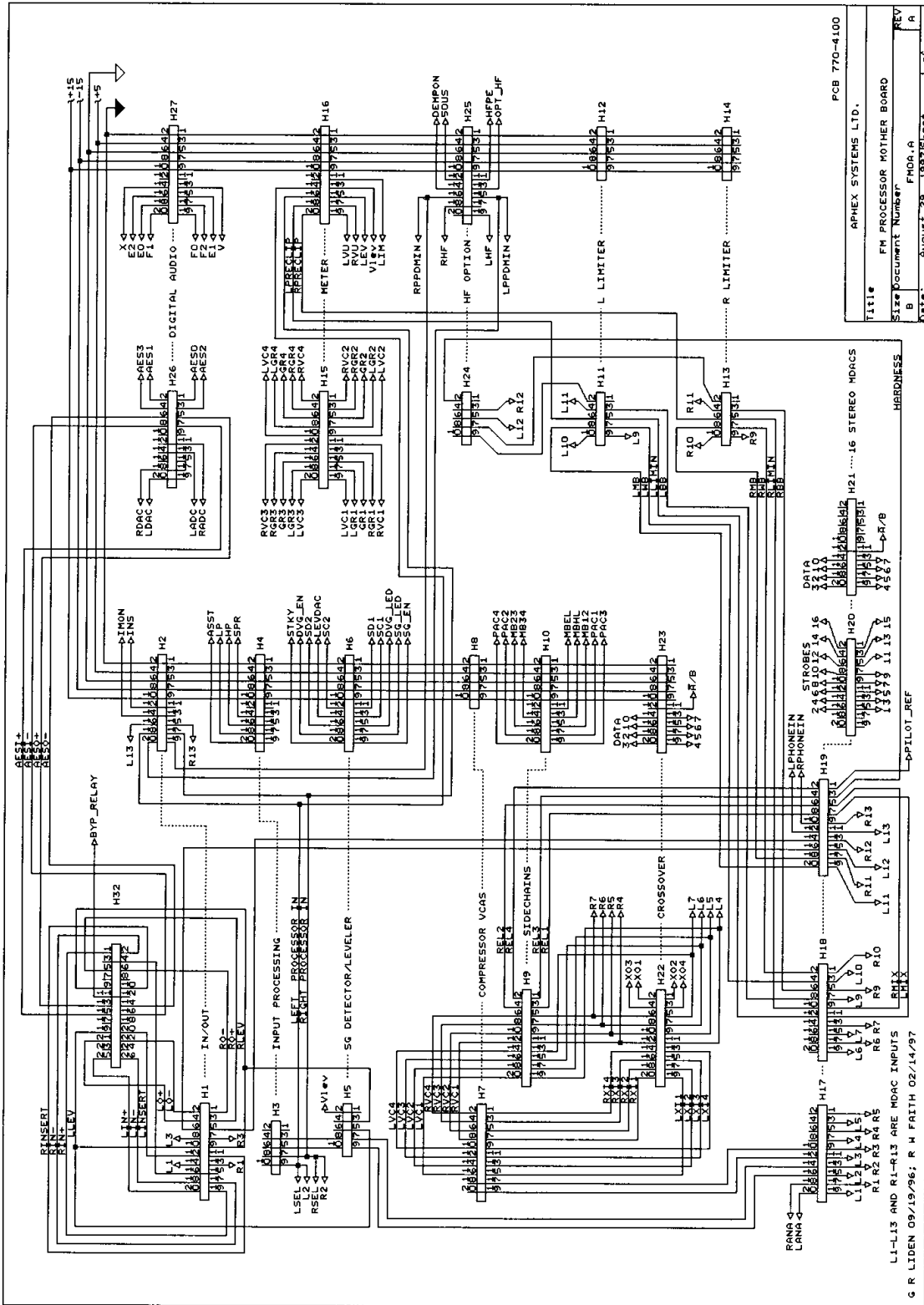

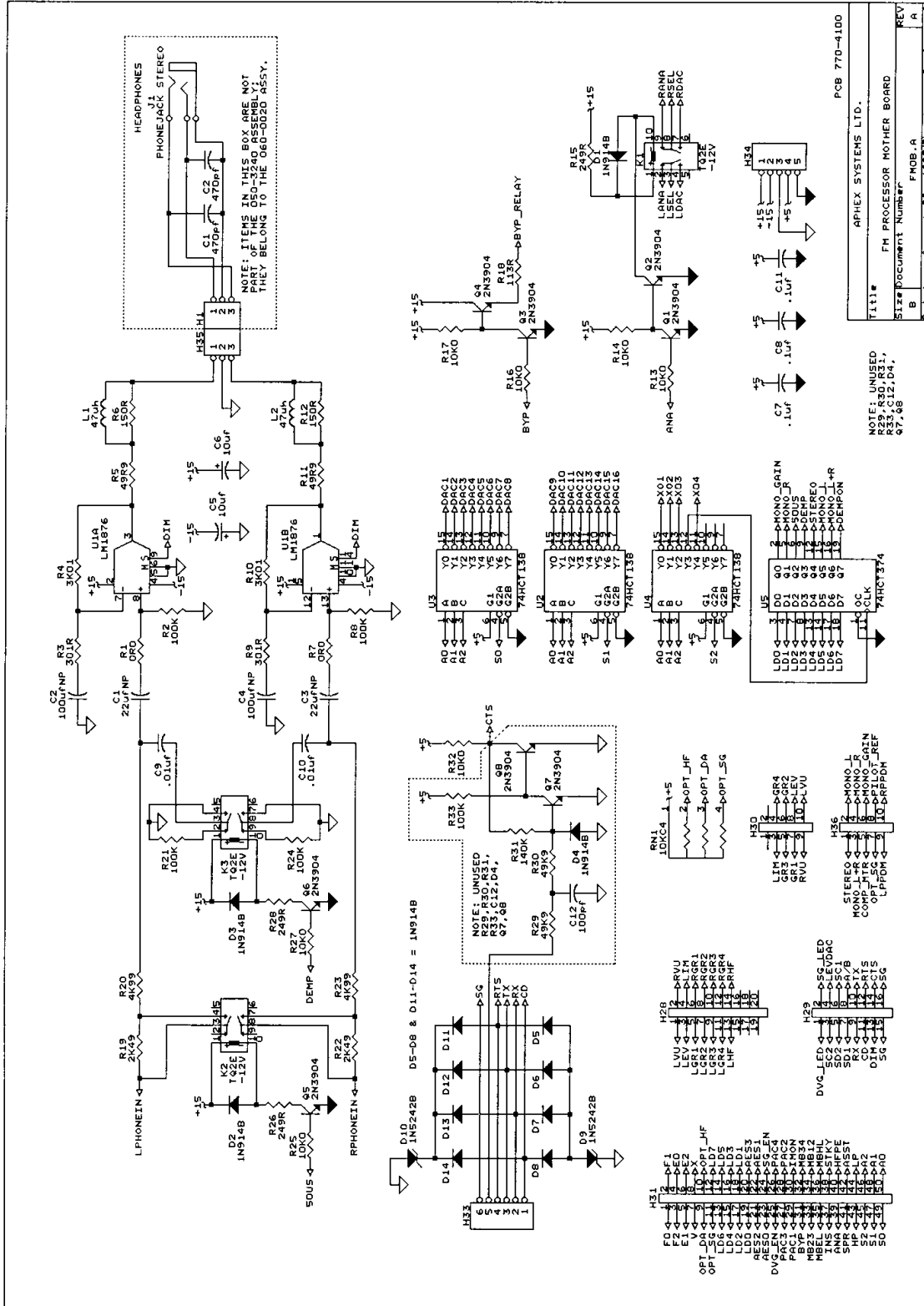

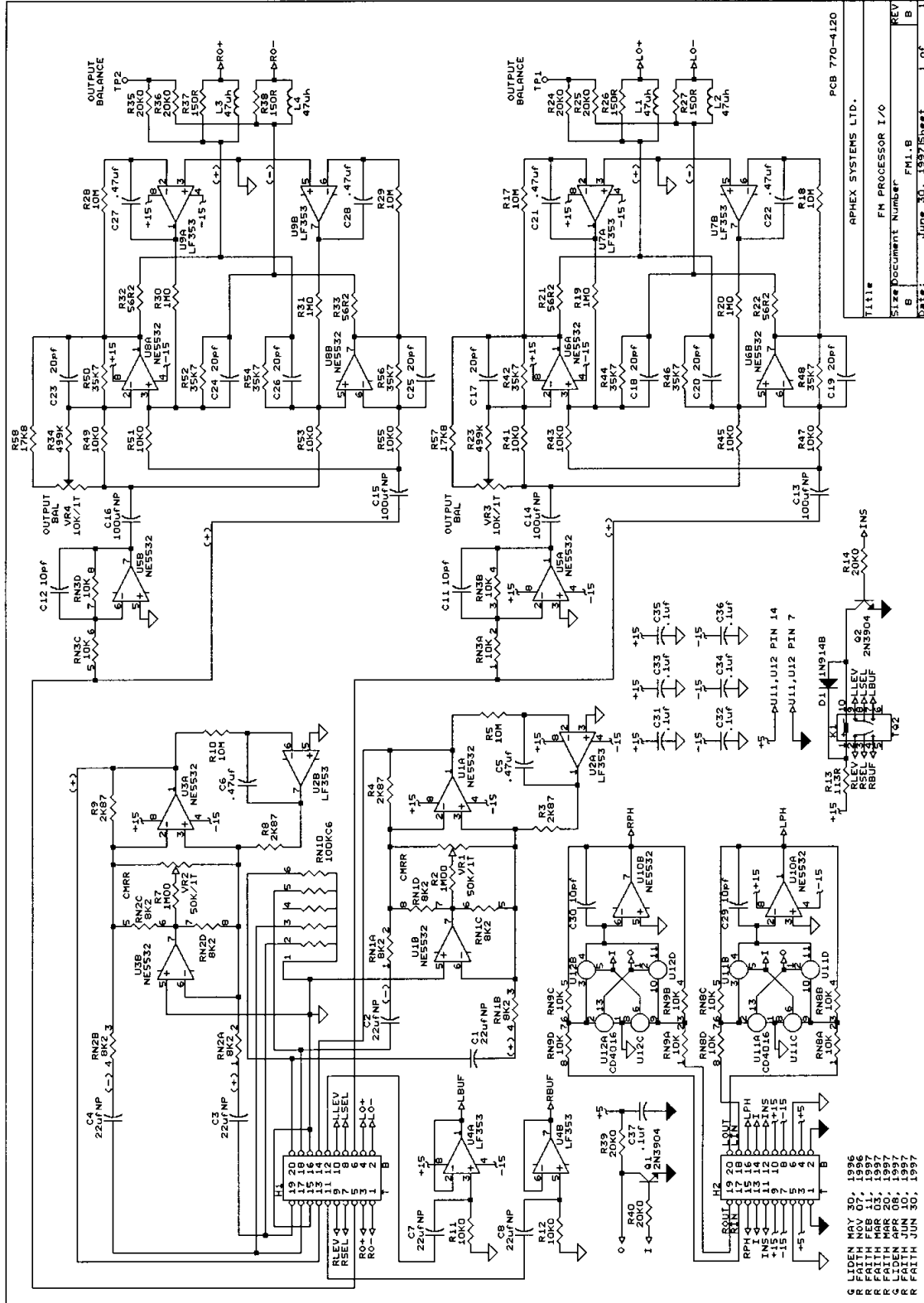

REV	B
Size	FMLB
Title	FM PROCESSOR I/O
Date	June 30, 1997
Sheet	1 of 1

Q	GREEN	NOV 20, 1996
R	FAITH	FEB 11, 1997
R	FAITH	MAR 20, 1997
R	FAITH	MAR 20, 1997
G	LIDEN	APR 08, 1997
R	FAITH	JUN 10, 1997
R	FAITH	JUN 30, 1997

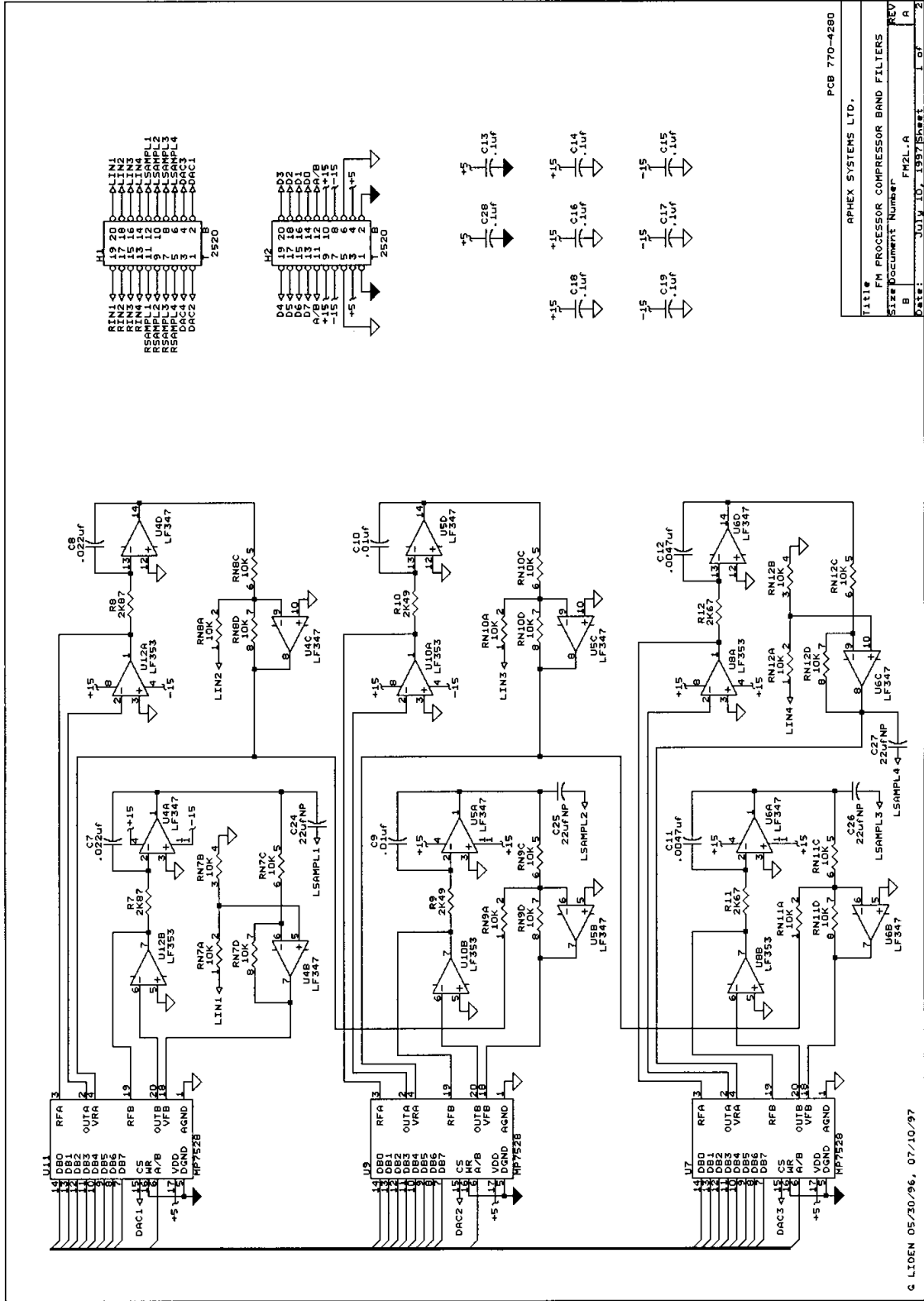

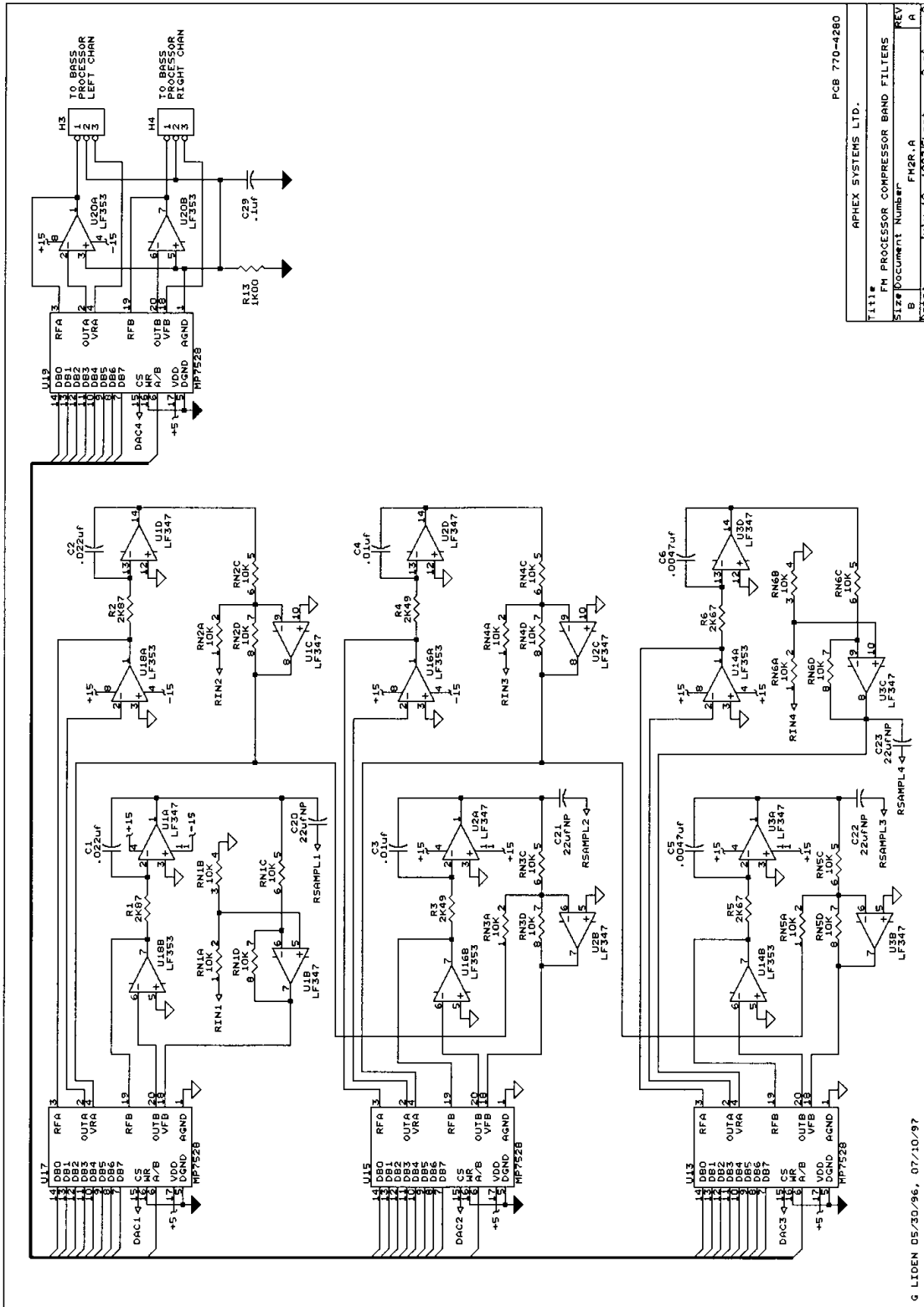

Title#		APHEX SYSTEMS LTD.	
Size		FM PROCESSOR COMPRESSOR BAND FILTERS	
B		FMR-A	
Date:		JULY 10, 1997	
Sheet		2 of 2	
REV		A	

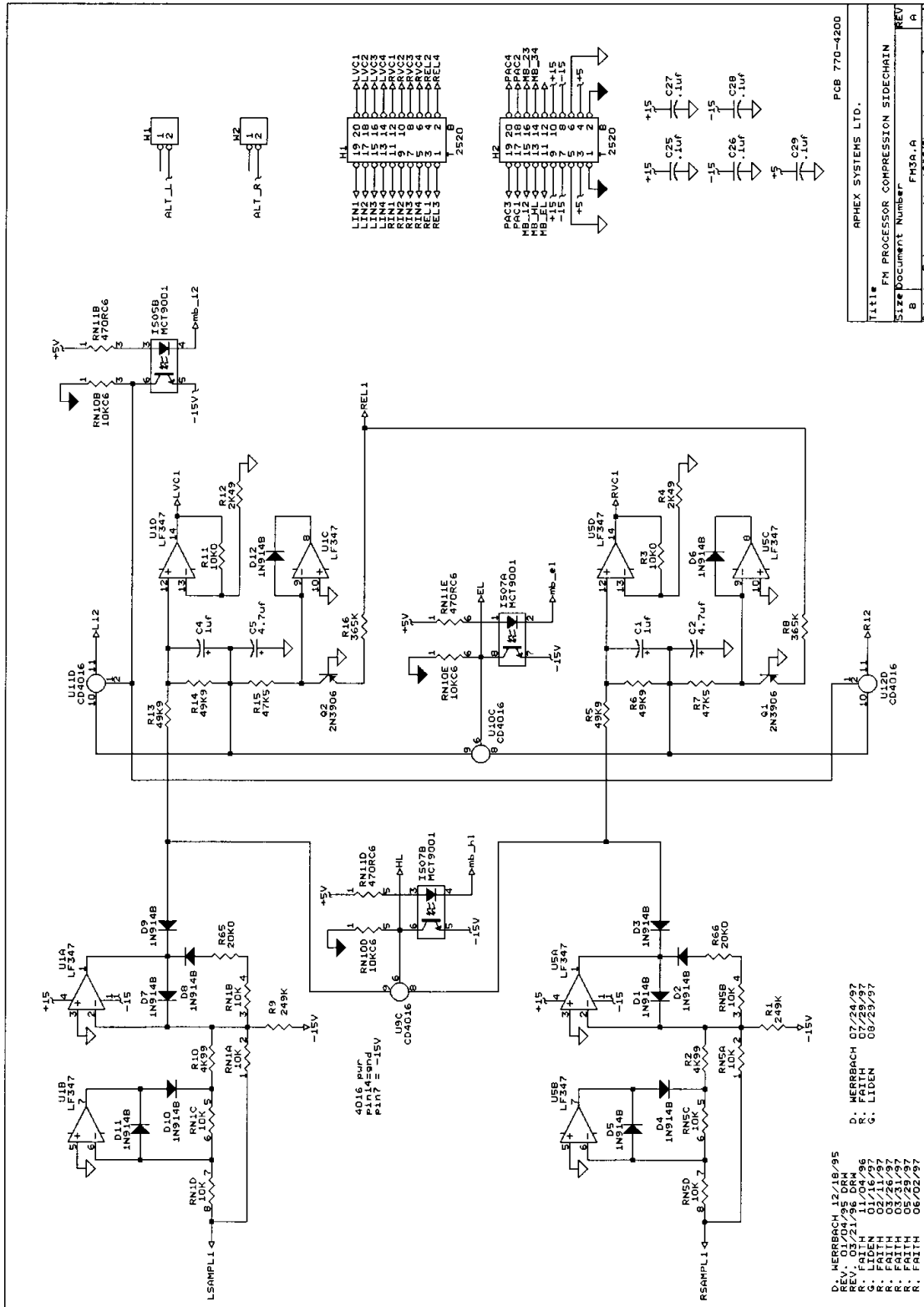

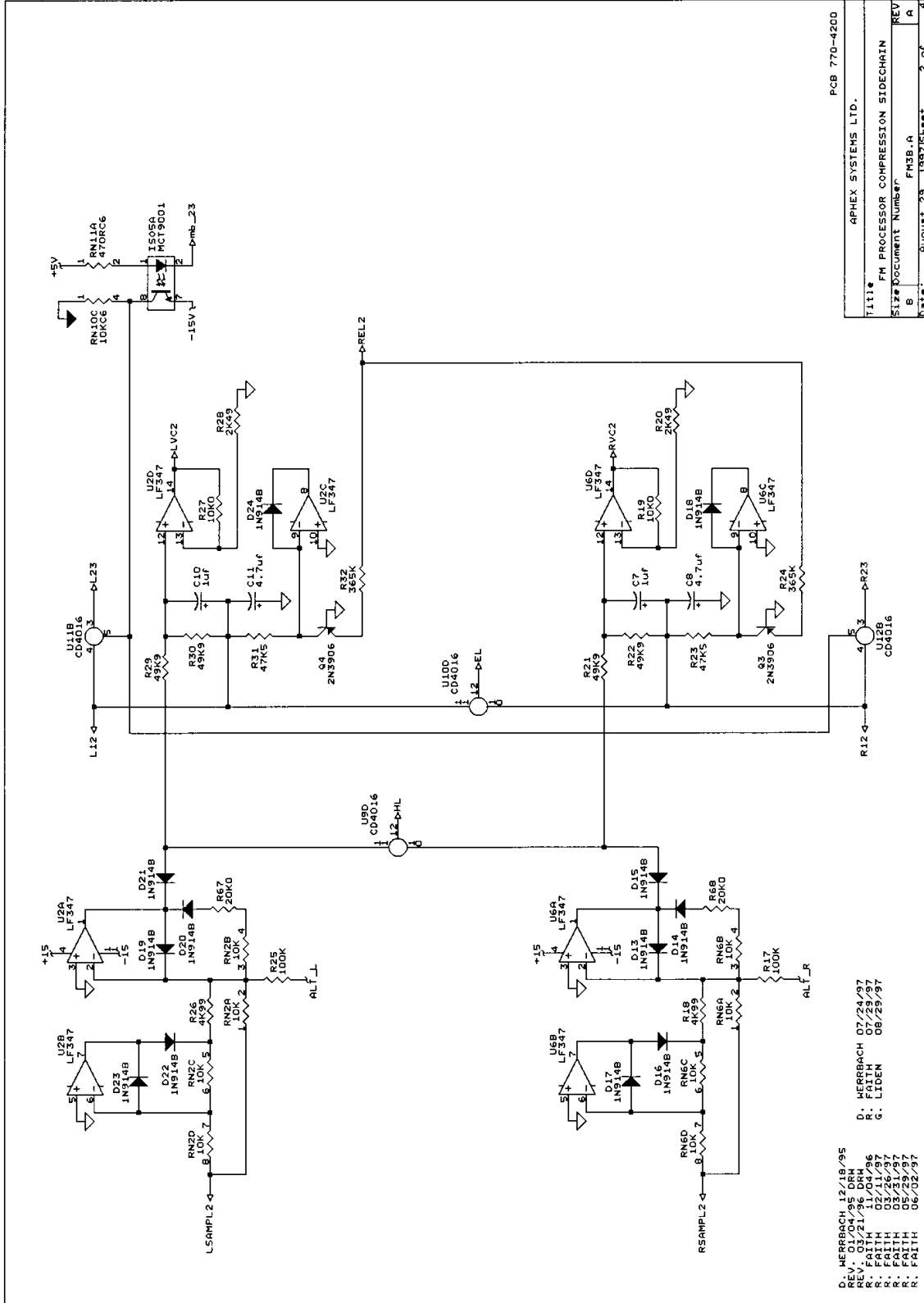

PCB 770-4200	
APEX SYSTEMS LTD.	
TITLE	FM PROCESSOR COMPRESSION SIDECHAIN
SIZE	Document Number
B	FM3B.A
REV	A
Date:	August 29, 1997 Sheet 2 of 4

D. HERRBACH	12/18/95
REV.	03/24/95 DRW
R. FAITH	11/04/96
R. FAITH	03/11/97
R. FAITH	03/31/97
R. FAITH	05/29/97
R. FAITH	06/02/97
D. HERRBACH	07/24/97
R. FAITH	07/29/97
G. LIDEN	08/29/97

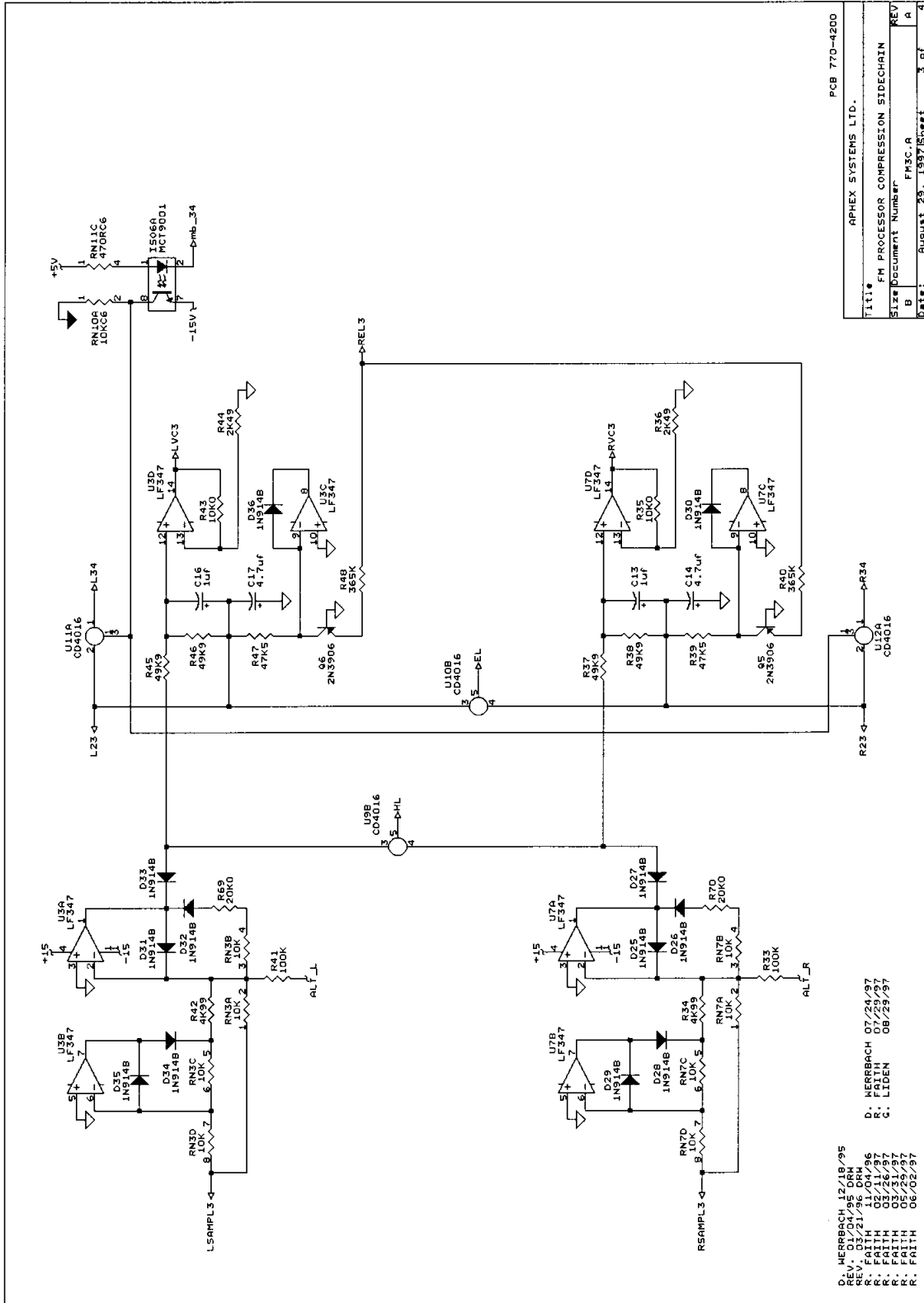

Title		APHEX SYSTEMS LTD.	
Size		FM PROCESSOR COMPRESSION SIDECHAIN	
REV	Document Number	REV	
B	FMSC-A	A	
Date:	August 29, 1997	Sheet	3 of 4

Q	HERBACH	12/18/95
REV	03/21/96	DRM
R	FAITH	07/24/96
R	FAITH	07/29/97
C	LITDEN	08/29/97
R	FAITH	03/23/97
R	FAITH	06/02/97

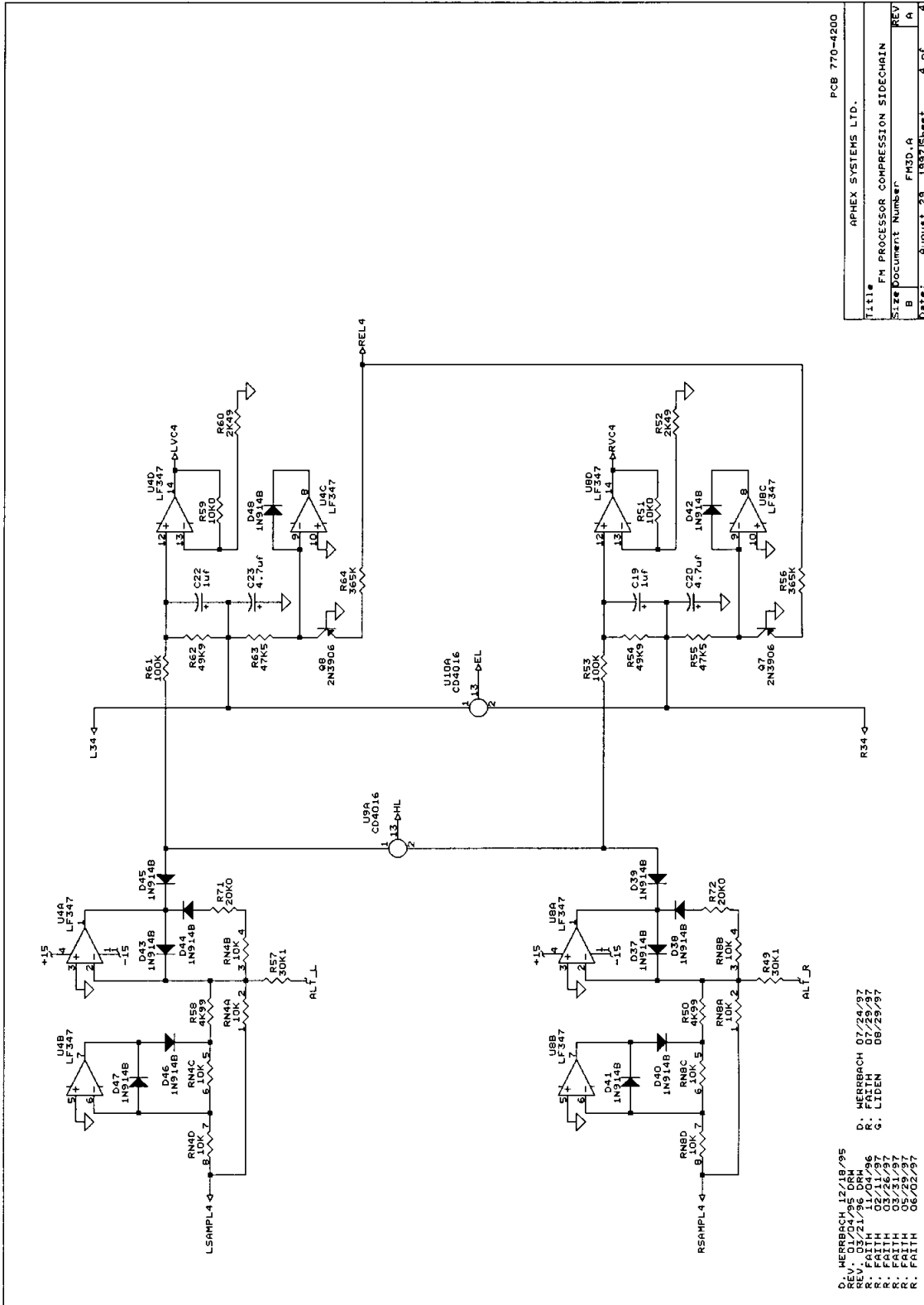

PCB 770-4200	
APHEX SYSTEMS LTD.	
Title	FM PROCESSOR COMPRESSION SIDECHAIN
Size	Document Number
REV	FA3D.A
REV	A
Date:	August 29, 1997 Sheet 4 of 4

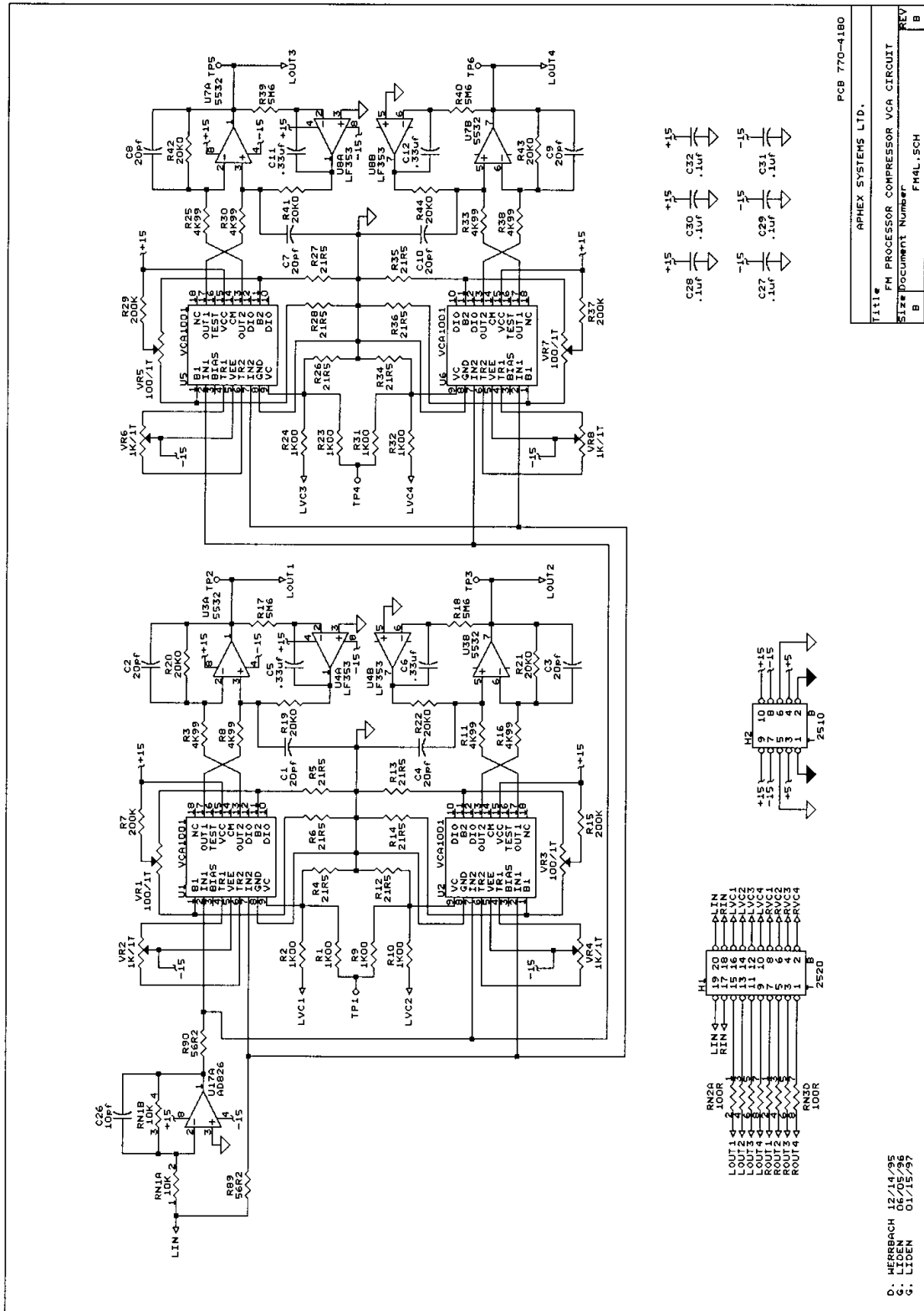

PCB 770-4180

Title	APHEX SYSTEMS LTD.
Size	FM PROCESSOR COMPRESSOR VCA CIRCUIT
REV	REV
B	B
Date:	April 11, 1997 Sheet 1 of 2

MERRBACH 12/14/95
 C. LIEN 06/05/96
 G. LIEN 01/25/97

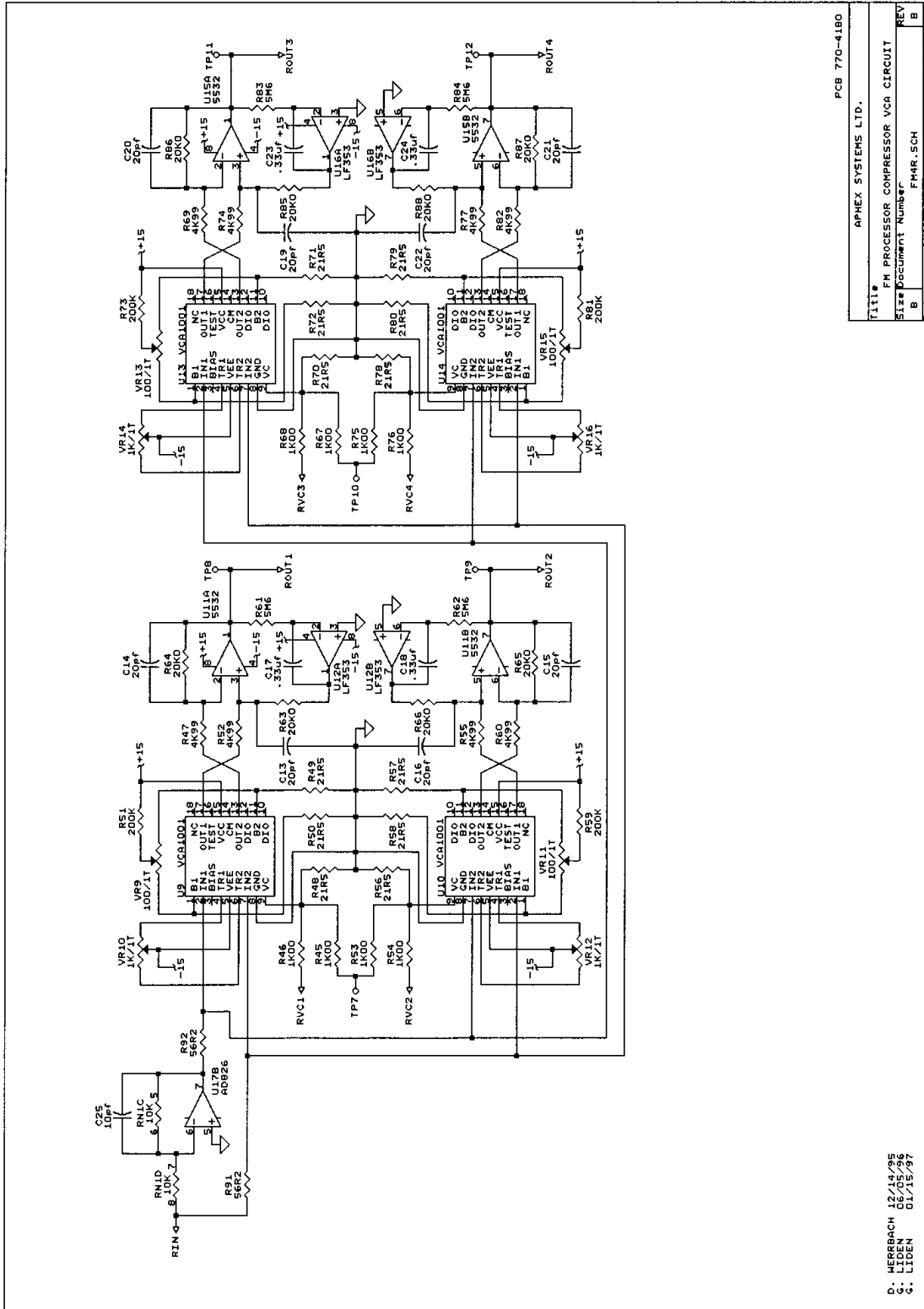

PCB 770-4180
 APHEX SYSTEMS LTD.
 TITLE: FM PROCESSOR COMPRESSOR VCA CIRCUIT
 Size: Document Number: REV B
 Date: 08/11/11, 1997/Sheet 2 of 2

D: HERBACH 12/14/95
 G: LIDEN 06/05/99
 G: LIDEN 01/15/99

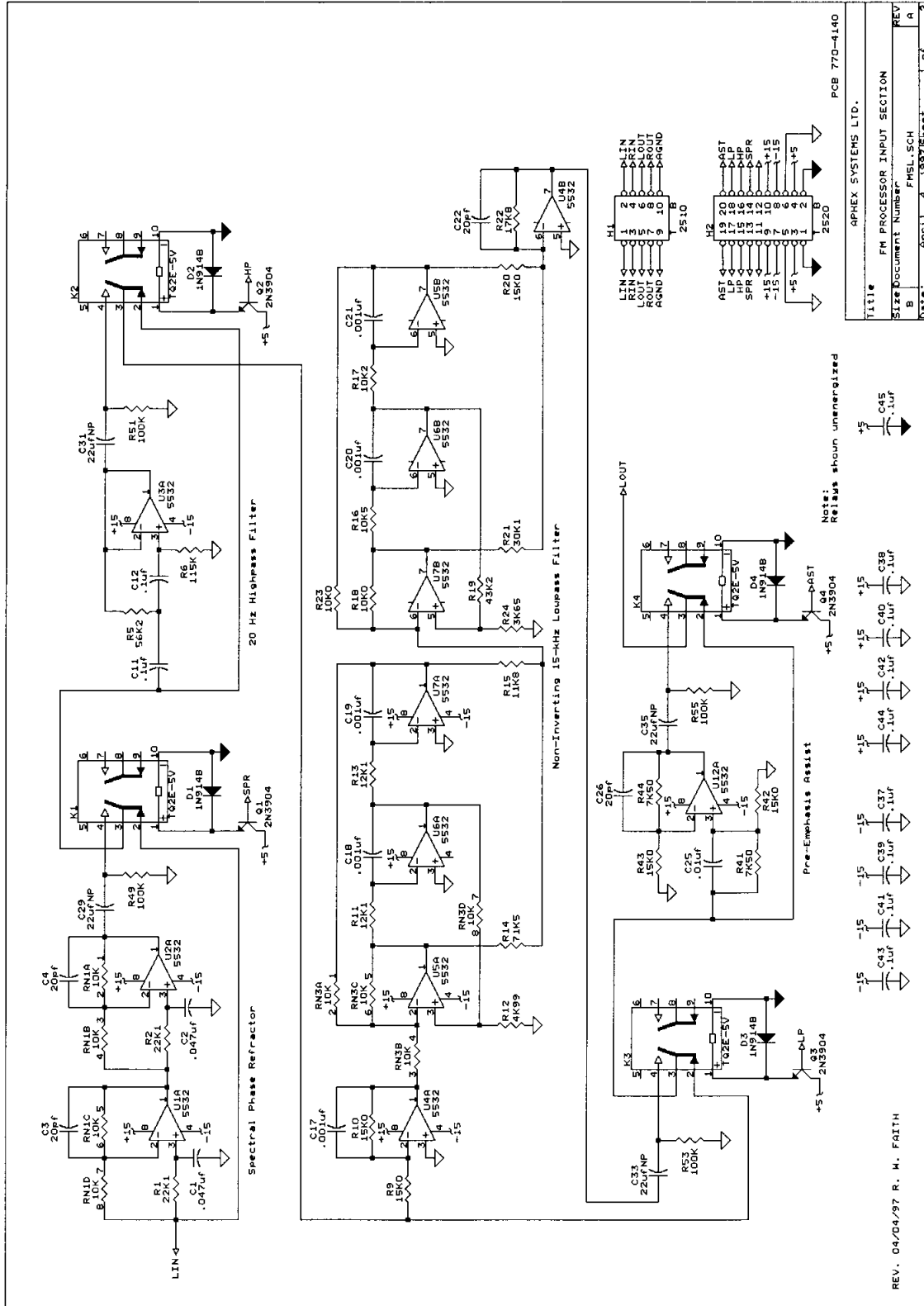

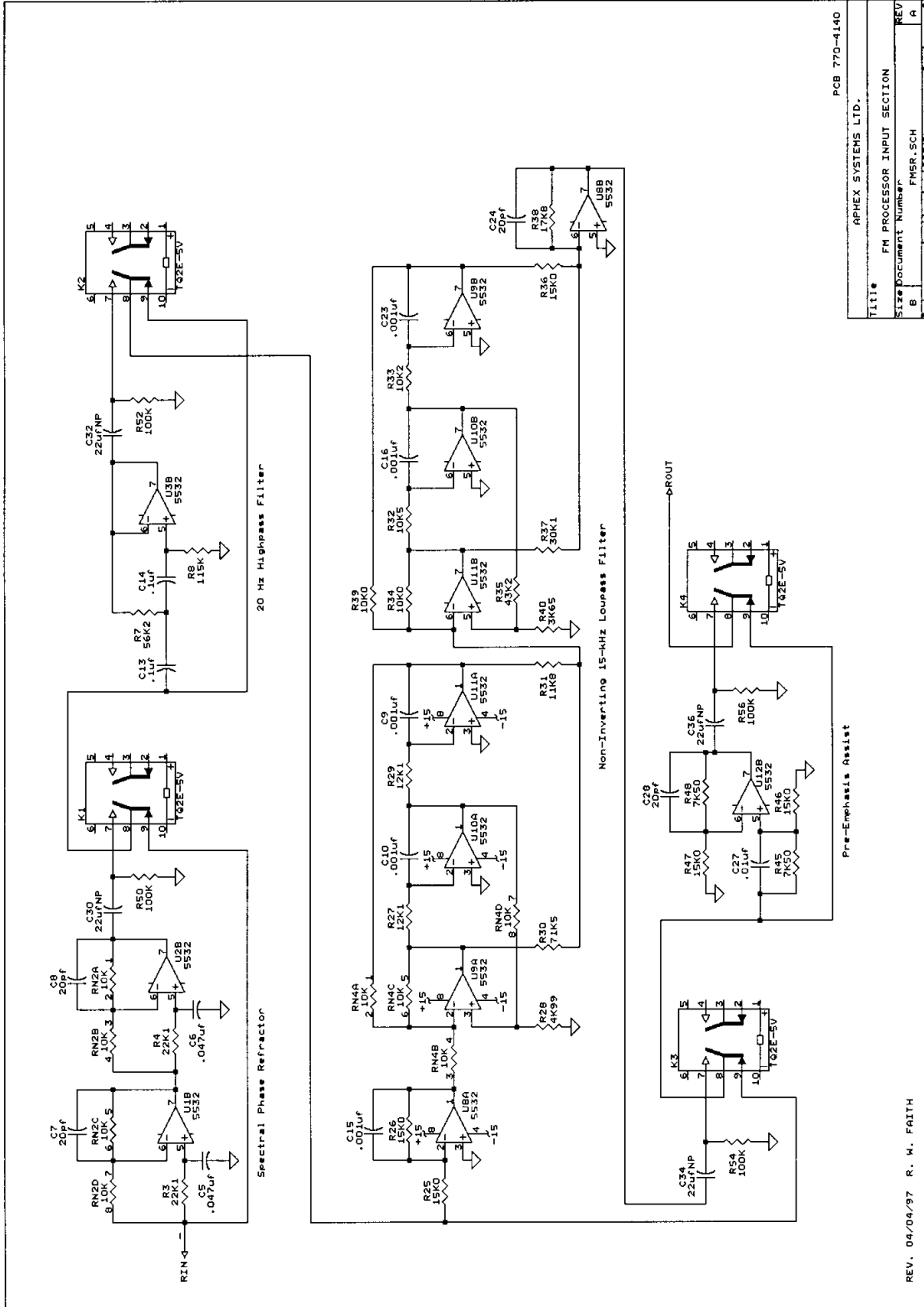

PCB 770-4140	
APHEX SYSTEMS LTD.	
TITLE#	FM PROCESSOR INPUT SECTION
Size Document Number	FMSR.SCH
REV	A
Date:	April 4, 1997 Sheet 2 of 2

REV. 06/04/97 R. M. FAITH

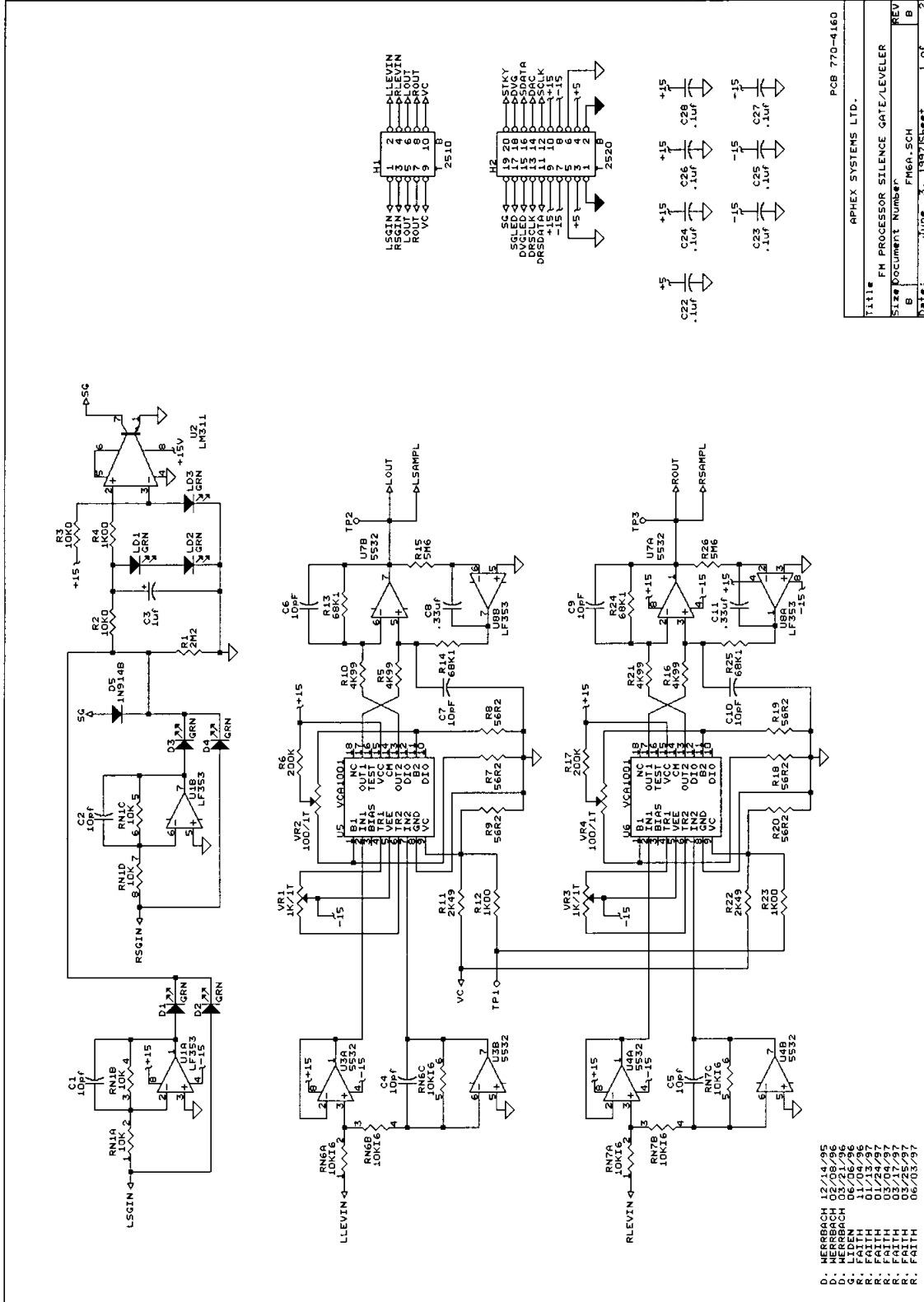

- D. MERRBACH 12/14/95
- D. MERRBACH 02/28/96
- D. MERRBACH 03/21/96
- R. FAITH 15/09/96
- R. FAITH 01/13/97
- R. FAITH 01/26/97
- R. FAITH 03/17/97
- R. FAITH 03/25/97

Title		APHEX SYSTEMS LTD.	
Size		FM PROCESSOR SILENCE GATE/LEVELER	
Document Number		FMEA.SCH	
REV	B	Date	June 3, 1997 Sheet 1 of 2

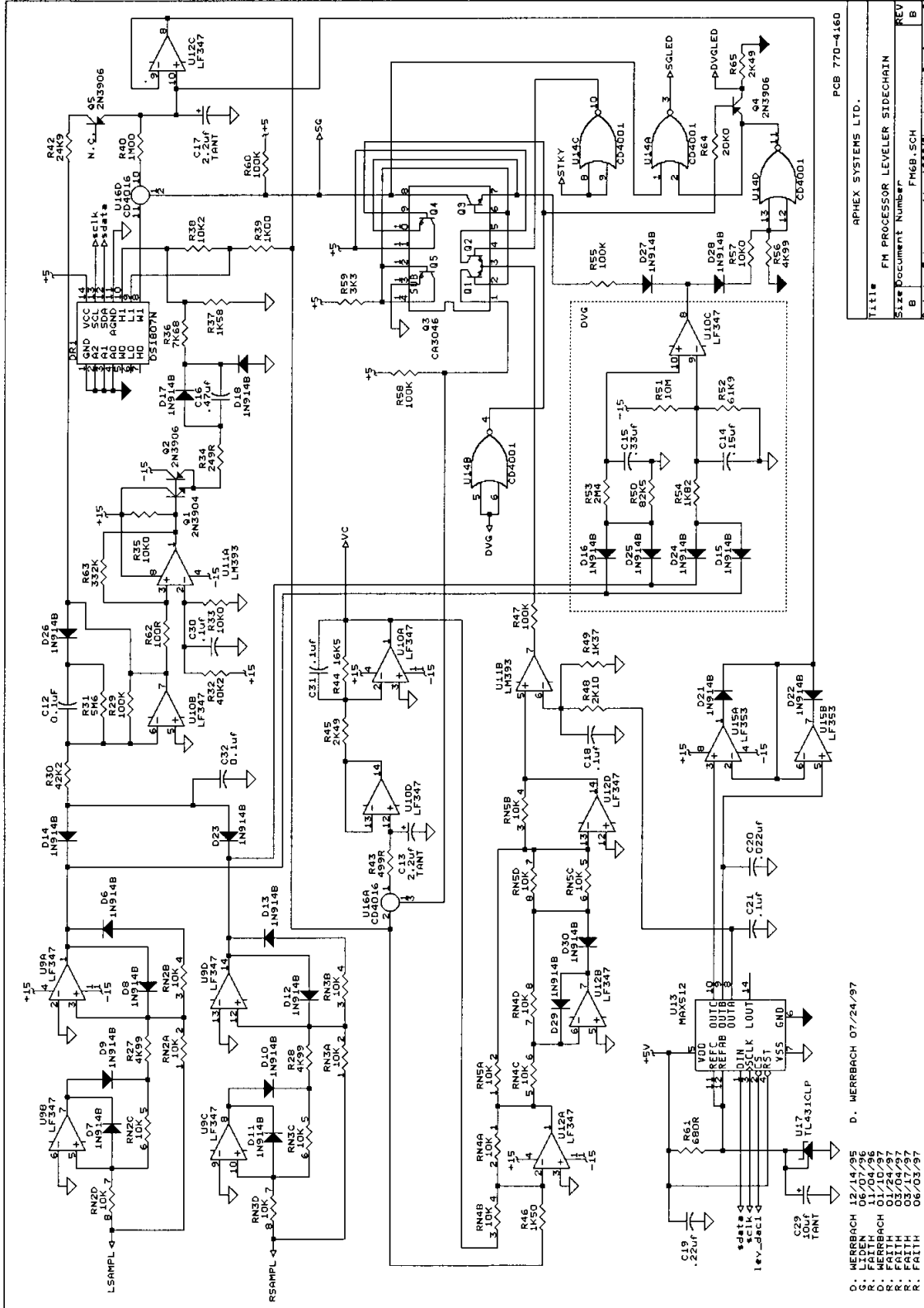

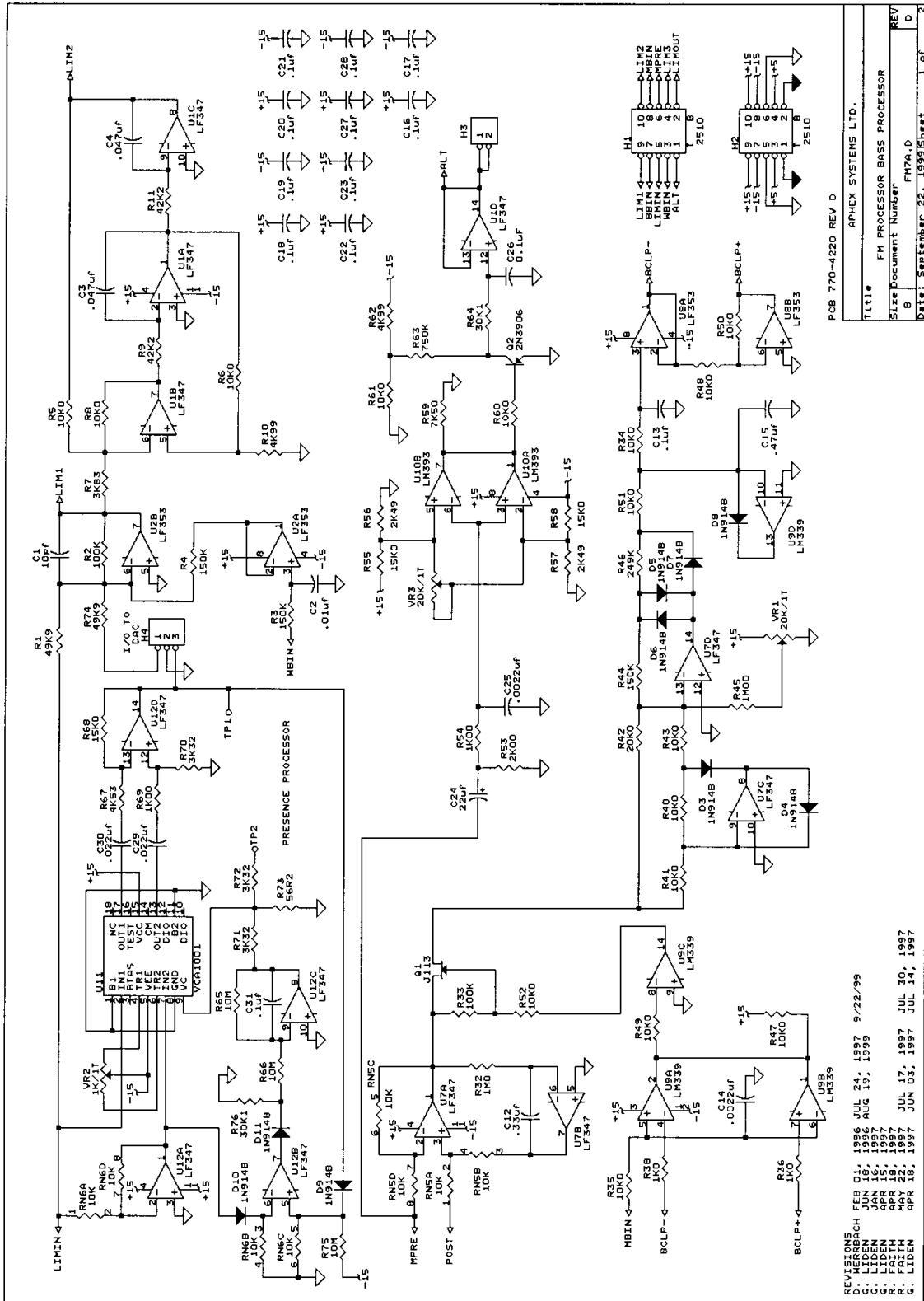

PCB 770-4220 REV D

Title#	APHEX SYSTEMS LTD.
Size	FM PROCESSOR BASS PROCESSOR
REV	Document Number
B	FMYA.D
D	Date: September 22, 1999
Sheet	1 of 2

REVISTIONS

D. MERRBACH	FEB 01, 1996	JUL 24, 1997	9/22/99
C. LIDEN	JUN 19, 1996	AUG 19, 1999	
G. LIDEN	APR 15, 1997		
R. CALTH	APR 19, 1997		
G. LIDEN	APR 16, 1997	JUN 03, 1997	JUL 30, 1997
		JUL 17, 1997	JUL 24, 1997

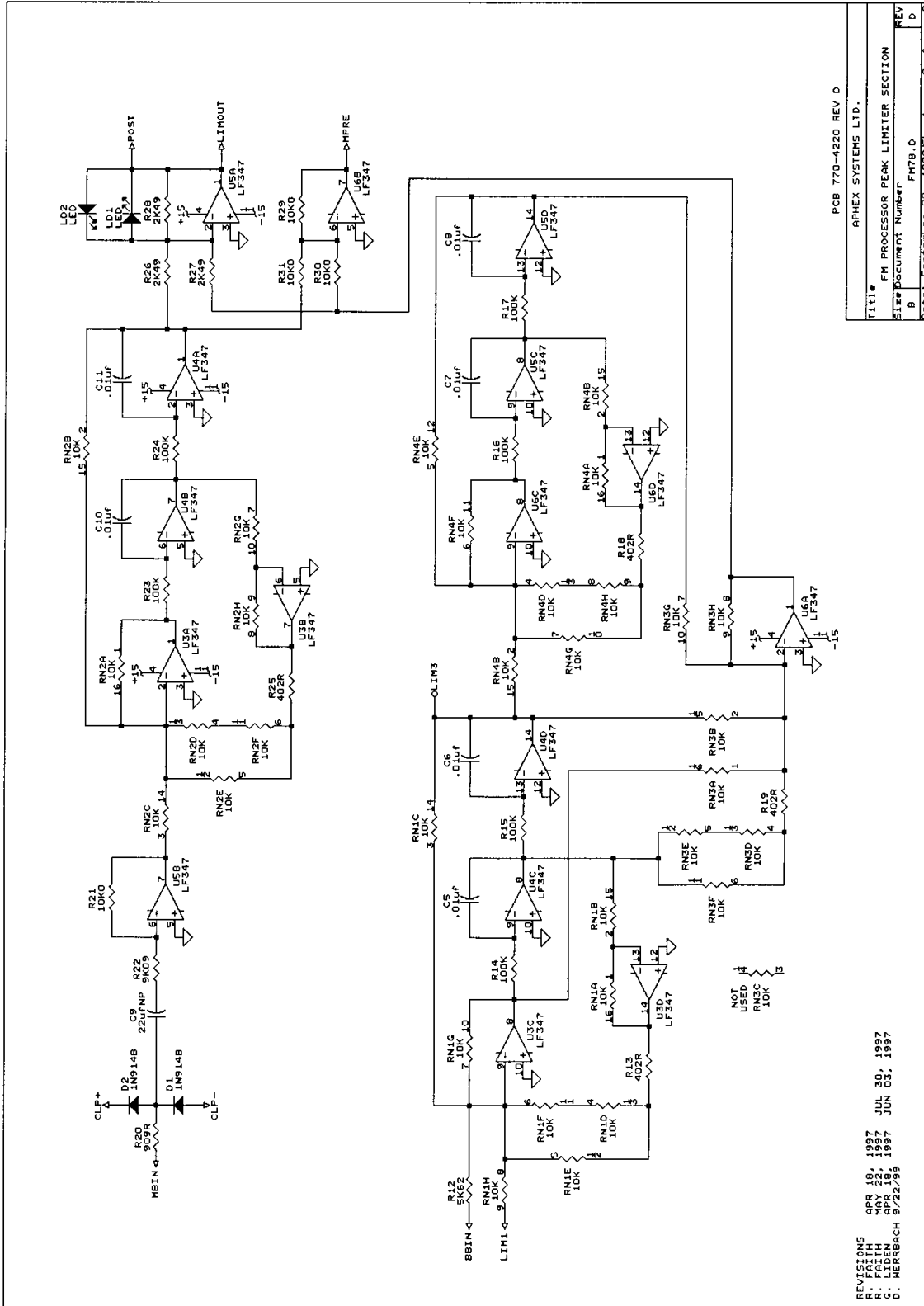

PCB 770-4220 REV D
APHEX SYSTEMS LTD.

Title: FM PROCESSOR PEAK LIMITER SECTION
Size: Document Number: FM7B.D
Date: September 22, 1993 Sheet 2 of 2

REVISIONS
R. FAITH APR 18, 1997
C. L. FLEM MAY 22, 1997
D. HERRBACH 9/22/95
JUL 30, 1997
JUN 05, 1997

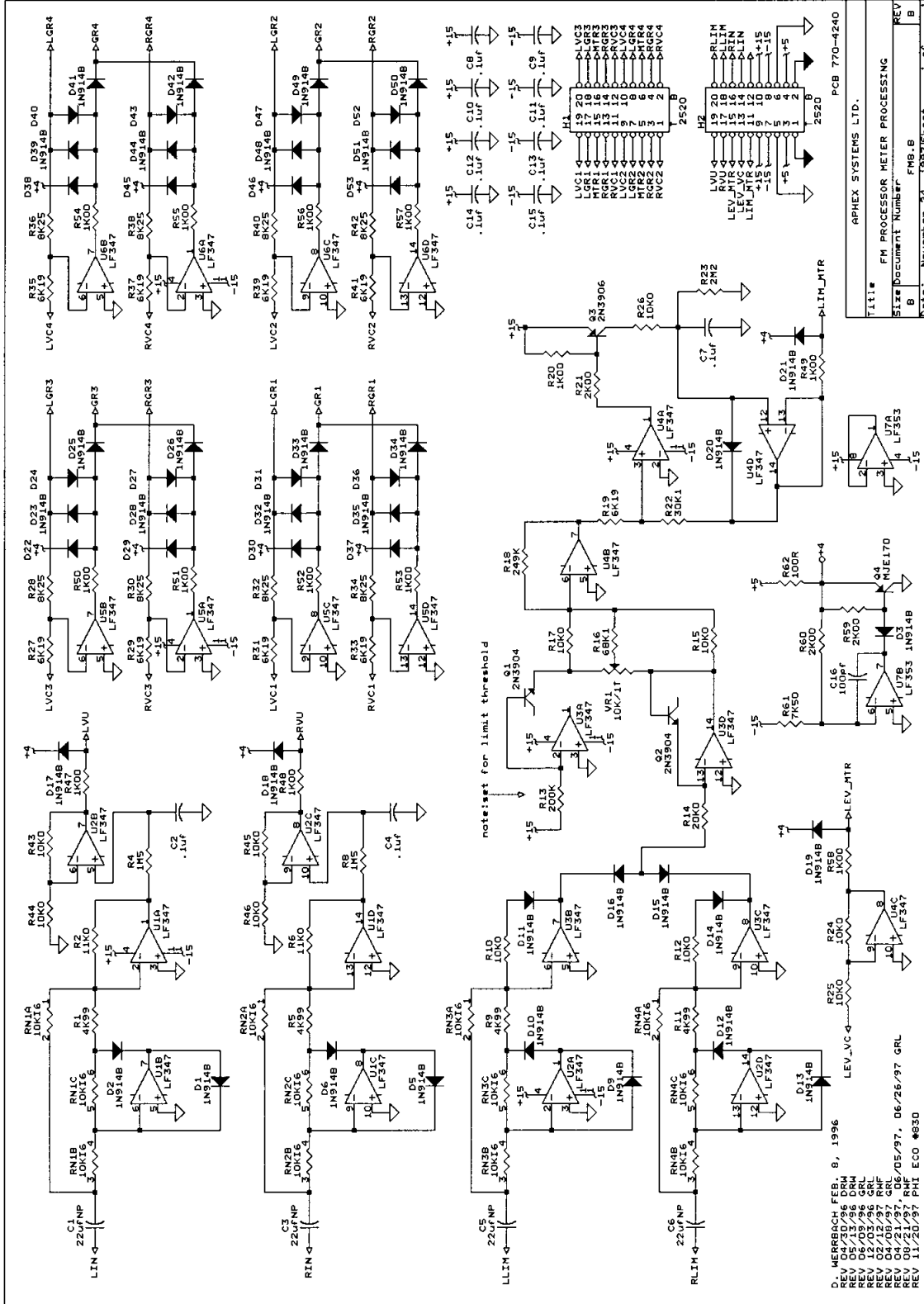

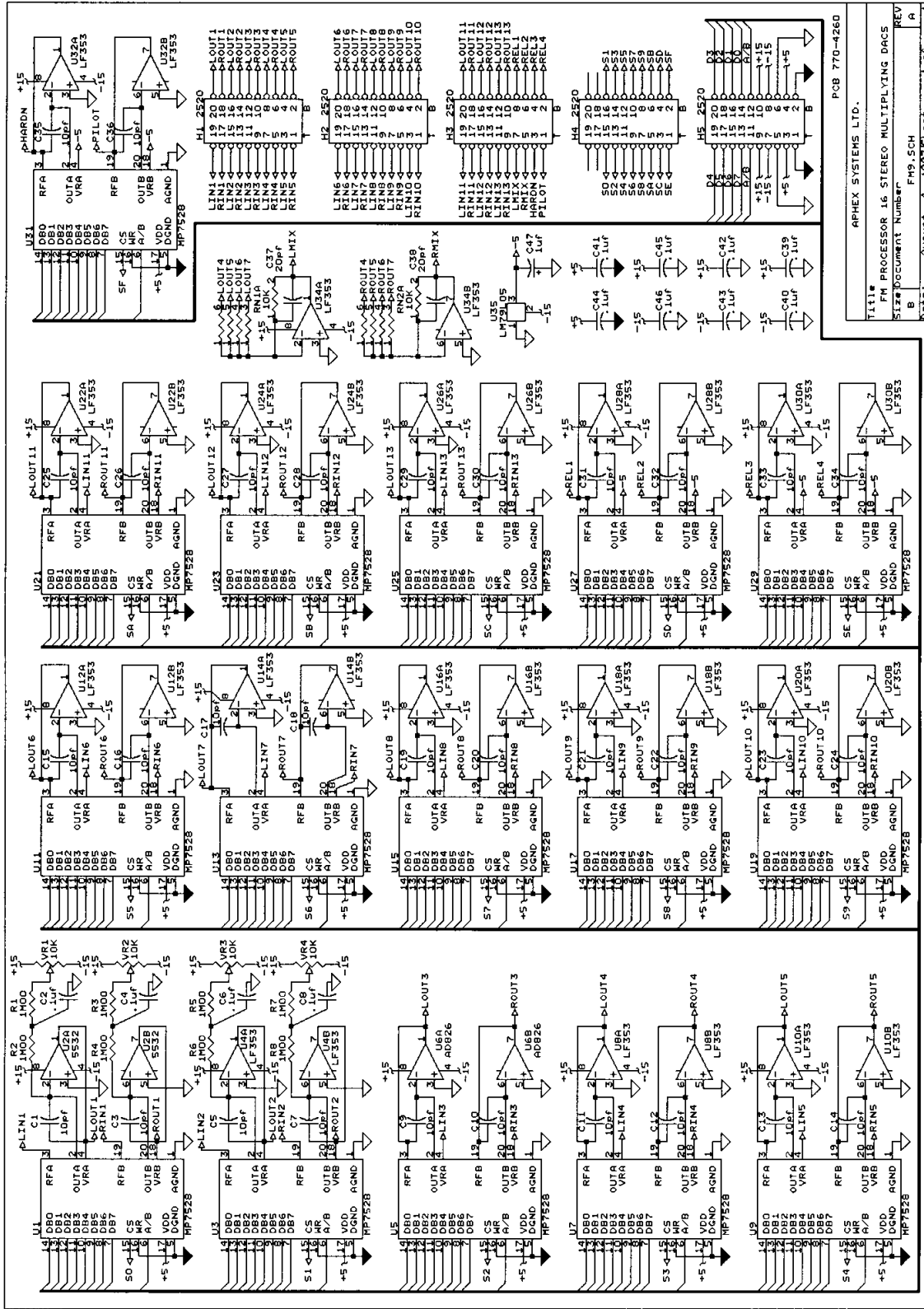

POB 770-4260
APHEX SYSTEMS LTD.
TITLE: FM PROCESSOR 16 STEREO MULTIPLYING DACS
SIZE: DOCUMENT NUMBER: FM9.5CH
REV: A
DATE: AUGUST 4, 1987 SHEET 1 OF 1

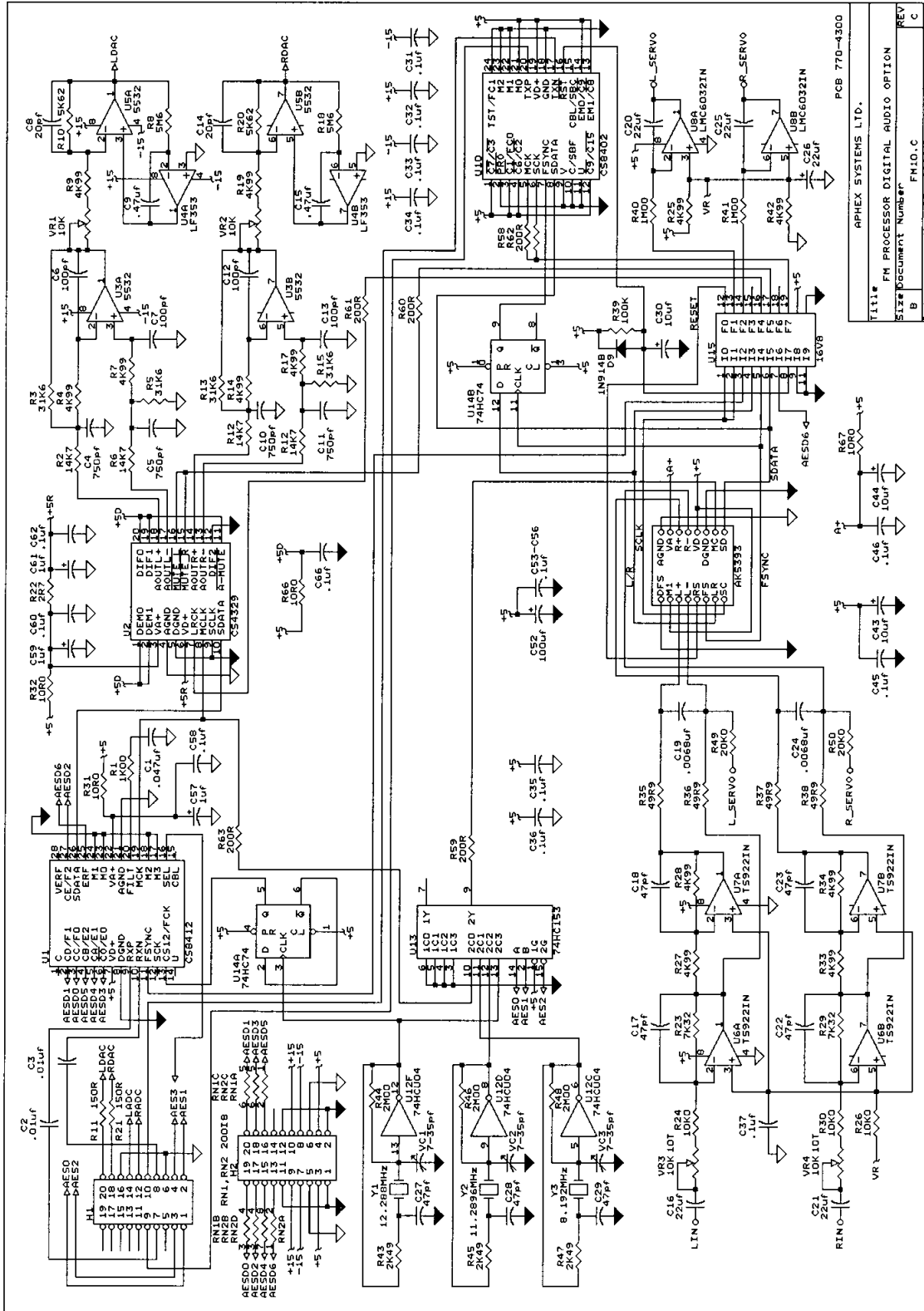

FILE#	FM PROCESSOR DIGITAL AUDIO OPTION
SIZE	PH10.C
REV	B
DATE	May 25, 2000
Sheet	1 of 1

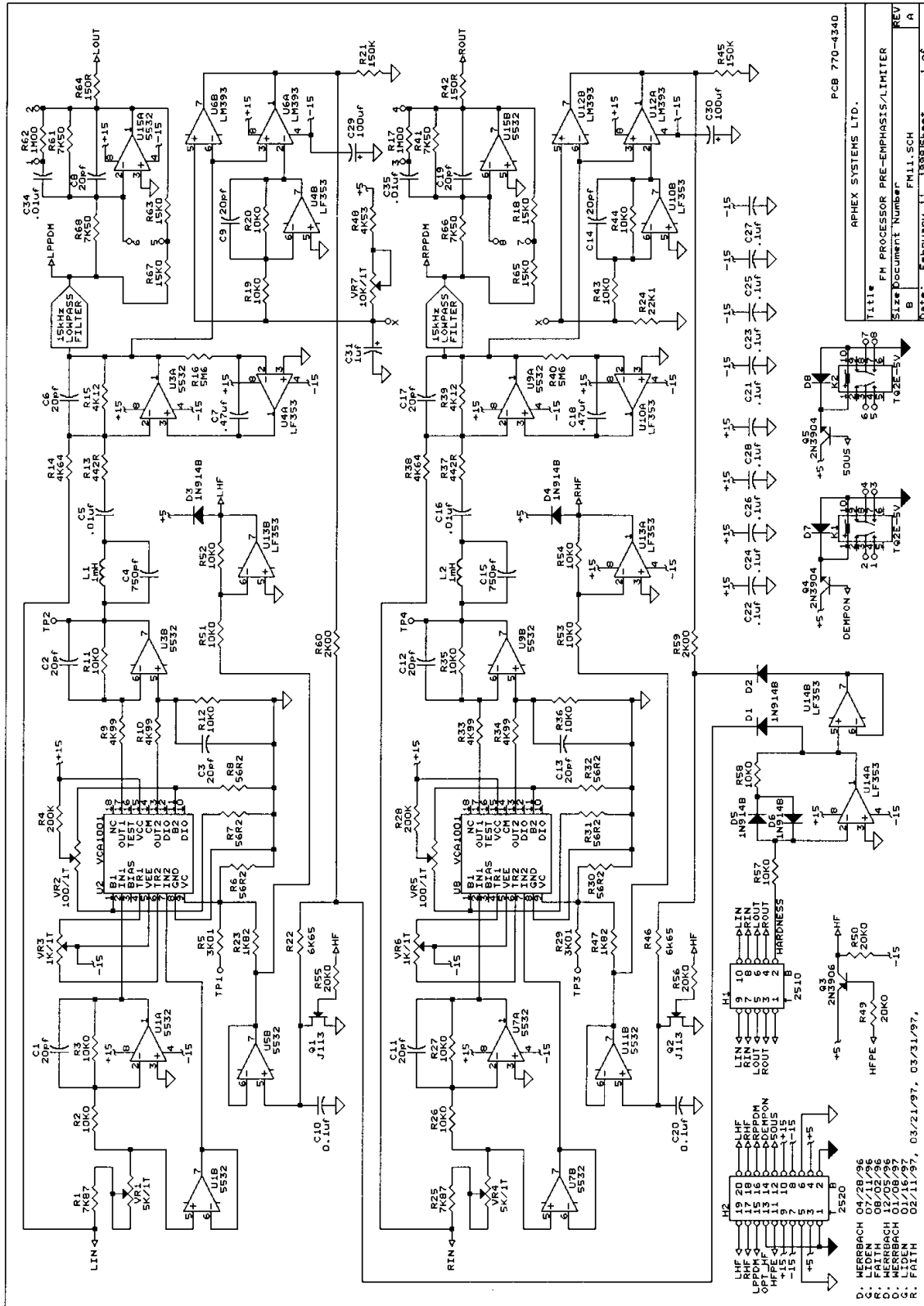

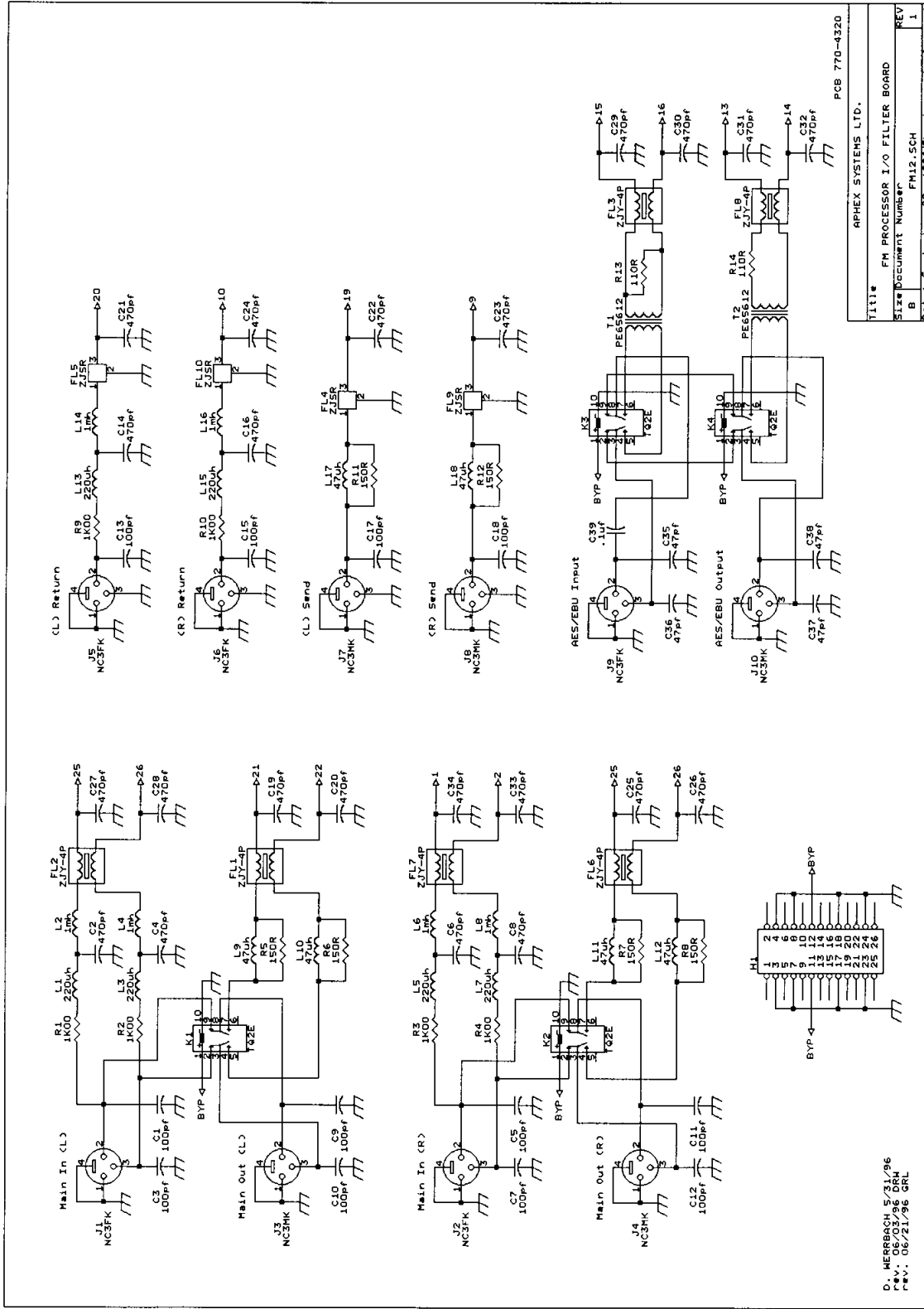

D. MERRICK 5/31/96
 P.W. 06/21/96 GRL

Title		FM PROCESSOR I/O FILTER BOARD	
Size	Document Number	PH12.SCH	
B	Date	September 29, 1996	Sheet 1 of 1

PCB 770-4320

APHEX SYSTEMS LTD.

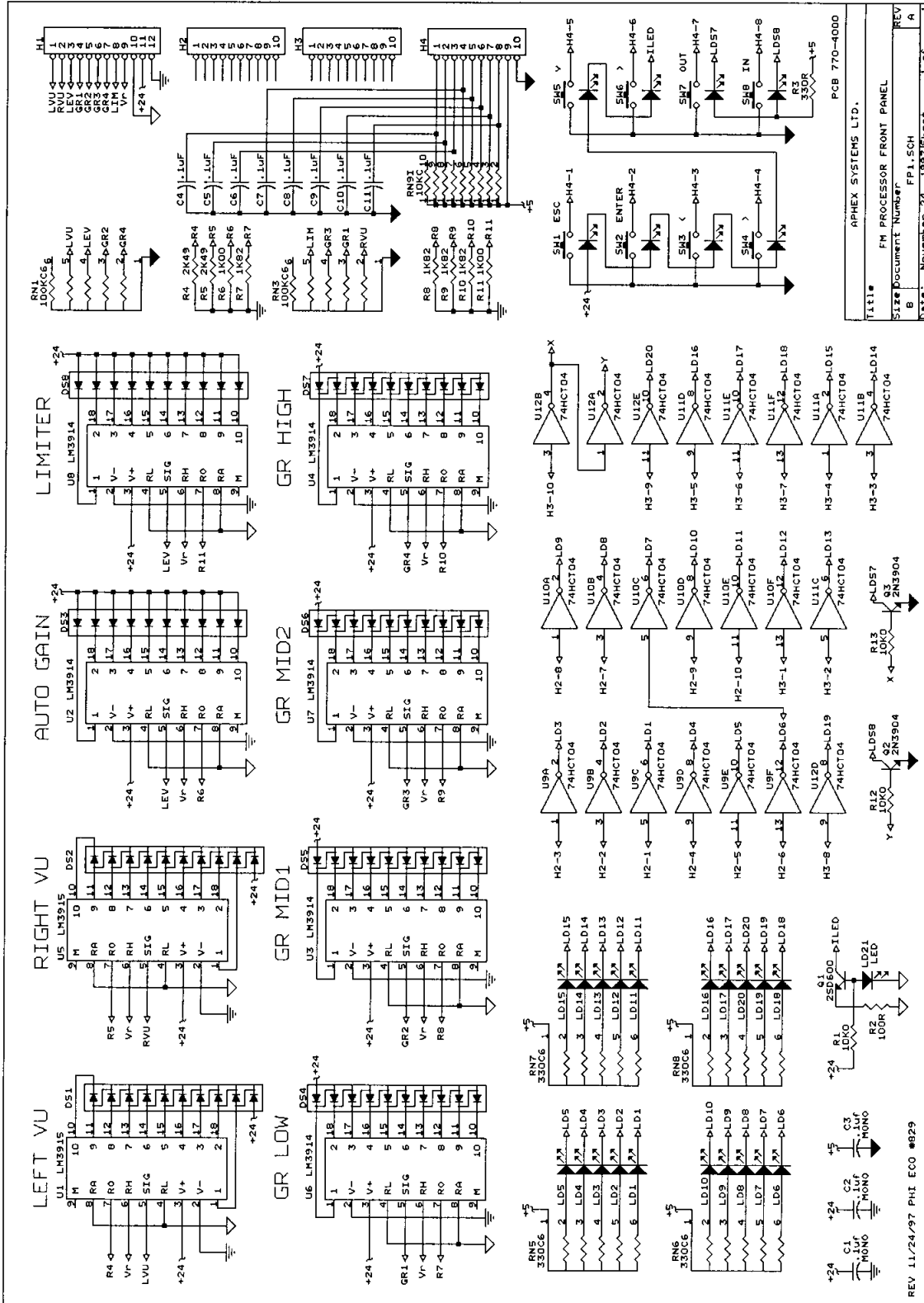

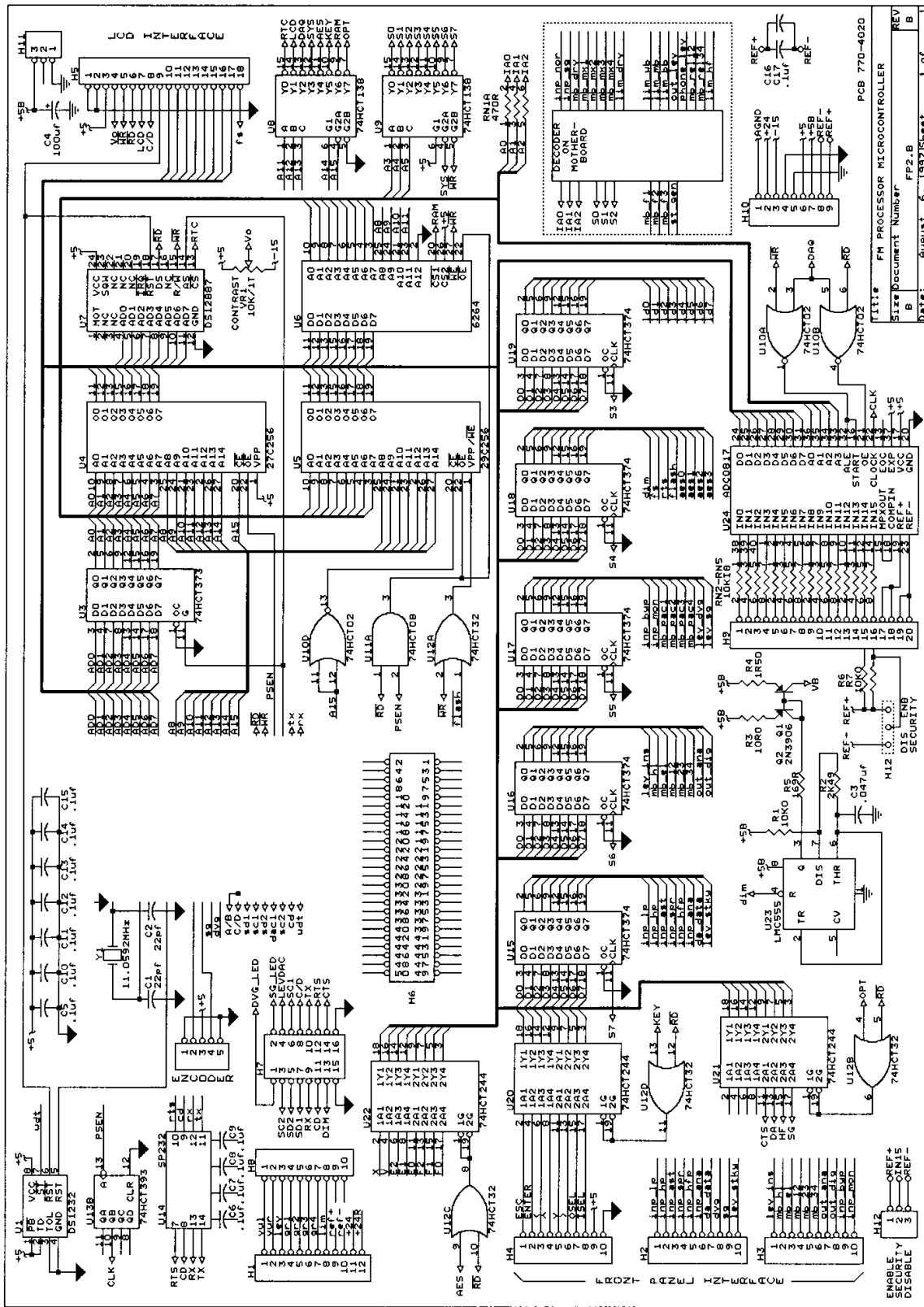

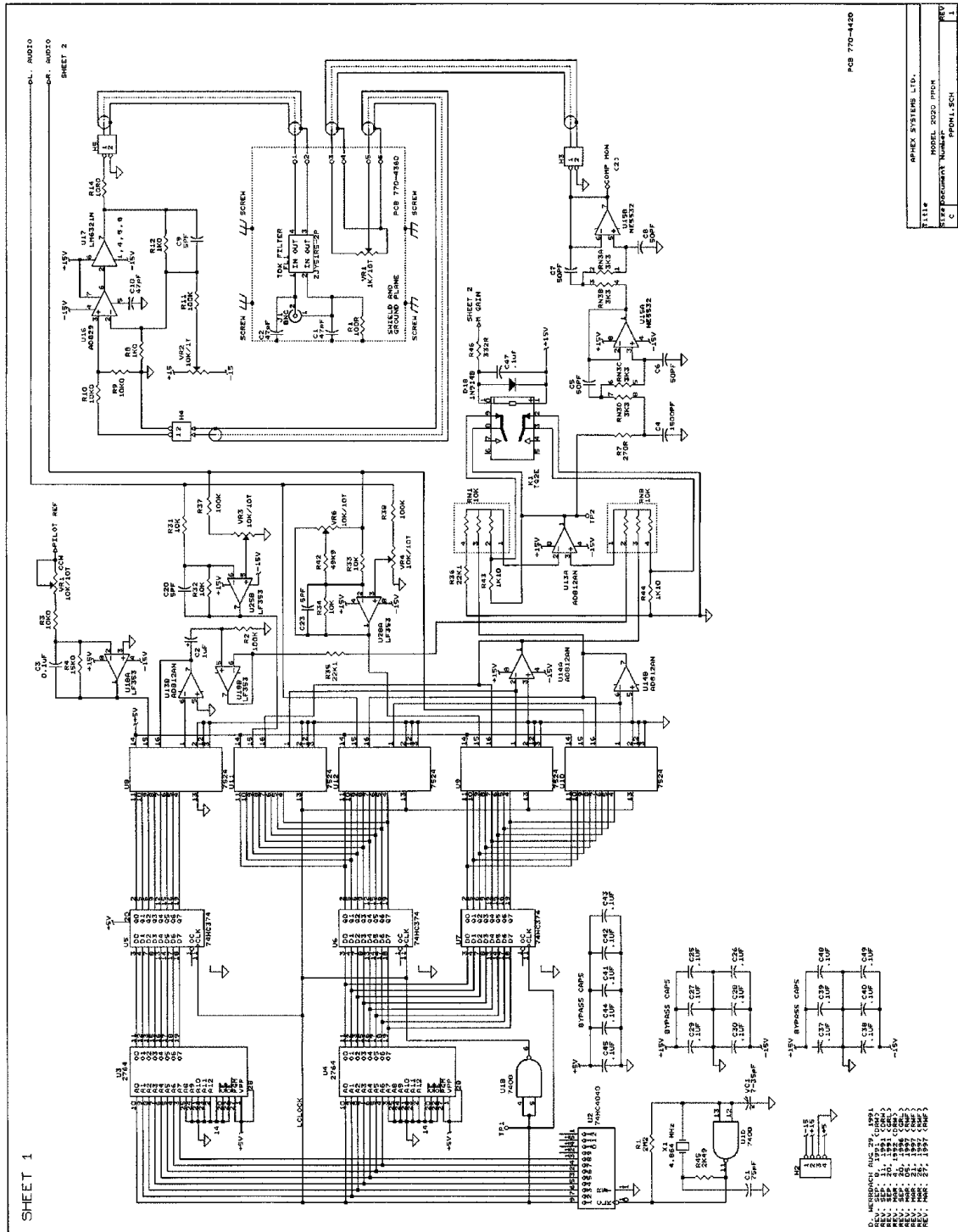

SHEET 2

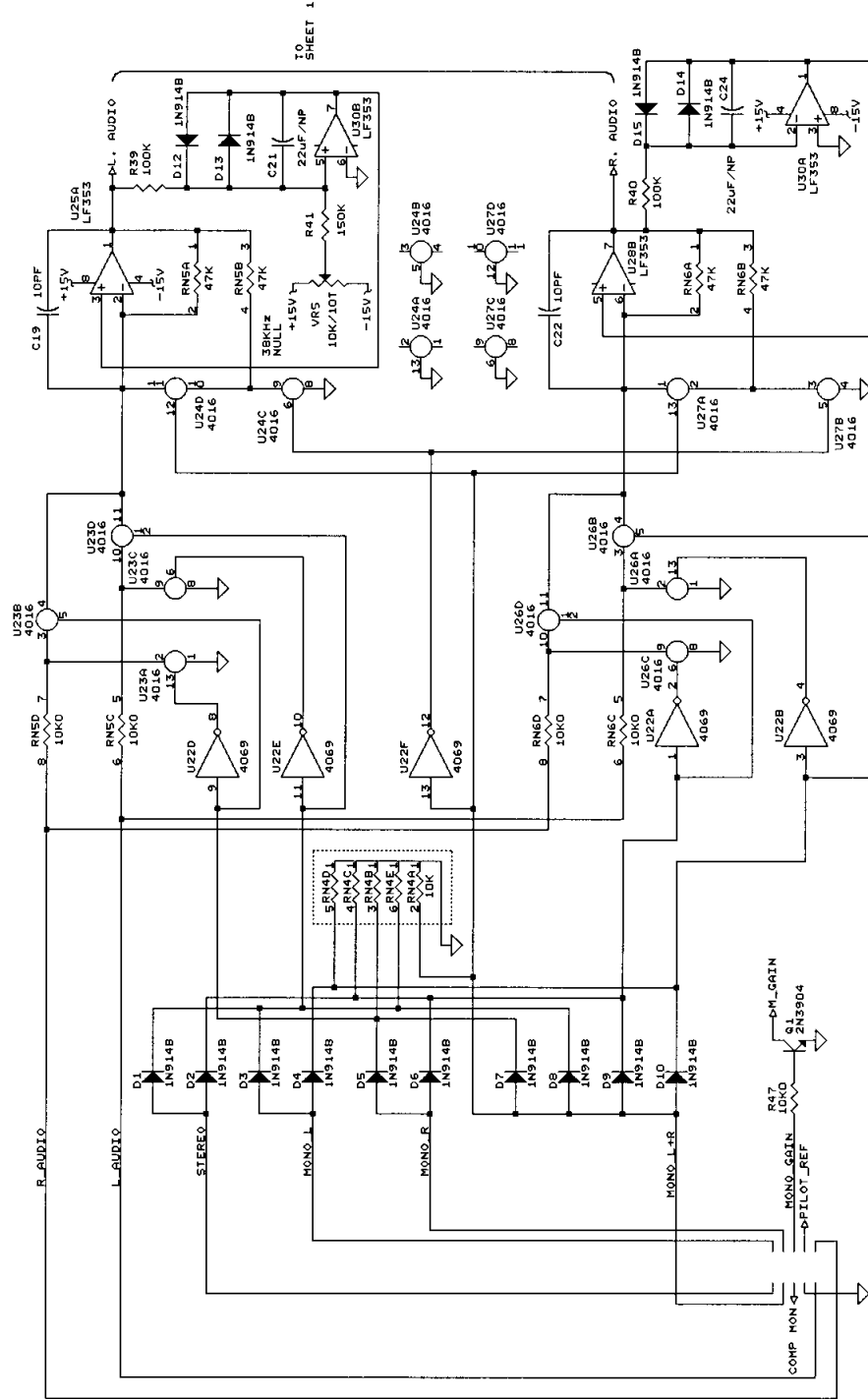

D:\HERRSCH\SEP_9_1991
 REV. MAR. 4, 1992 (DRM)
 REV. SEC. 20, 1995 (GRU)
 REV. MAR. 21, 1997 (RMF)
 REV. MAR. 26, 1997 (RMF)
 REV. MAR. 27, 1997 (RMF)

PCB 770-4420
 Title APHEX SYSTEMS LTD.
 Size Document Number MODEL 326 PPDH
 B PFDH2.SCH
 Date: March 27, 1997 Sheet 2 of 2