

Contents List

- **Circuit description**

- **Circuit diagrams**
 - L958AY power supply board
 - L965AY pre-amp board
 - L928AY display board
 - L870AY phono board
 - L955AY multi-channel board

- **Transformers**
 - L923TX – 115/230VAC toroidal
 - L922TX – 100VAC toroidal
 - L907TX – 100VAC frame

- **Exploded view diagram**

- **Mechanical & packing parts list**

- **Circuit board silk screen & parts list**
 - L928AY display board
 - L955AY multi-channel board
 - L958AY power supply board
 - L965AY pre-amp board
 - L870AY phono board

C30 preamplifier circuit description.

Introduction

The **C30** pre-amplifier uses pre-amp input switching/control and display boards that are very similar in design to the boards used in both the **Diva A85/A90** and **Fmj A32 integrated** amplifiers and as such you may already be familiar with the layout and topologies of these boards. The C30 boasts a very much over-engineered power supply and output stage that is designed to bring the very best out of the existing Pre-amp input switching board.

The main PCB **L958AY** also contains output buffers for the unbalanced outputs to drive long cables and balanced line drivers. A headphone amplifier is included to drive low impedance headphones down to 32 Ohm. For description of the pre-amplifier switching and control board see the section...

Power supply.

The mains input comes in via SKT1. Two **Y caps** return common mode noise to the chassis ground and an **X cap** reduces any single ended noise. The **1M5** resistor following this is in place to discharge the capacitors when the unit is turned off.

The mains selector switch, which follows the resistor, changes the configuration of the transformer windings from series for 230V to parallel for 115V. **Tx1** is a standby transformer it powers the microcontroller at all times so that the unit can be put into and out of standby. To reduce voltage losses after this transformer, low forward drop diodes are used. A low drop out regulator follows to create the **4.5v(D)** supply; this supply powers the micro and digital circuits.

The primary of the Toroid supply transformer **Tx2** is connected to **CON3** and the power to this is switched on and off by the relay **RLY1**.

The transformer has a number of secondary outputs and we use separate taps and bridge rectifiers networks followed by bulk capacitors to smooth the ripple. The voltages generated are **+24V** and **-24V** for the main analogue supplies, **+46V** for the **HT** supply to the **VFD**, and **+18V**, which is used to power the trigger output. The smoothed **+/- 24V** then goes through regulators **REG 2** and **REG 5** to create **+/- 18V** this is passed the pre-amplifier PCB via **CON4**. Another set of regulators **REG 3** and **REG 6** follow taking the **18V** and creating a **+/-15V** supply that is available for add on modules such as the 7.1 channel input board. A **5v** supply is derived via regulator **REG 4** from the **18V** to run the headphone amplifier.

Mains detect.

A mains present detector runs from the standby transformer, this detects the loss of mains using a peak hold circuit based around **D7/TR1/DZ1** and **TR2**. If the power is lost this piece of circuitry sends a flag to the microcontroller so it can mute the outputs and shut down the unit. **See Fig 1** for notes on **protection modes**.

12v trigger and RC5 receiver.

The trigger output on **SKT2** is driven through **TR4** to provide a current limited supply at around **13V**.

IC1 A and **B** are used to demodulate incoming **RC5** from socket SKT2. IC1A is a band-pass filter centred on **36KHz**. This is followed by a peak detector circuit that demodulates the incoming signal.

Fig 1. Protection and mute mode and measurements.

Prot line	Measured at.	Working reading
AC present	Resistor R12	+4.5v
Mute*	Con 8 Pin 5	+4.5v
Standby*	Resistor R5 at point P18	.7v
Trigger	ResistorR10 at point P54	+1.8v

Pre-amp input card.

Introduction.

The pre-amp stage is a high-performance, DC coupled design with microprocessor control of input select, two independent tape loops, electronic volume control and tone bypass.

It features a discrete power supply and low-noise linear circuitry to obtain exceptionally low distortion and noise performance results.

Power supply stage

The secondary transformer output windings from the main toroid transformer are connected to **SK300**. The A.C voltage is rectified and smoothed by **D300, D301, D306, D307** and **C300, C301**. The unregulated voltage should be around +/- 27 V obviously this is dependent on the A.C level at the mains inlet socket; **F300** and **F301** are the secondary A.C s.m fuses these are rated at 2A.

The voltage regulators are discrete emitter followers the +15 voltage stage is described below as the -15 v stage is effectively very similar.

Q300 and **R300** act as a constant current source, supplying around 7mA into **D310**. **C302** and **C314** reduce ripple and broadband noise on the zener diode. **Q305** and **Q306** form a complementary Darlington NPN transistor, which is configured as an emitter follower producing +15v at it's output. **C303** is to provide bulk charge storage and to reduce the AC output impedance of the power supply.

D302 prevents reverse bias of the supply during power down.

Z301 is a conventional LM317 type circuit to regulate the +15v rail down to +5v for the tone and volume control circuits.

Input switching

Each of the inputs has a pair of diodes to the +/- 15v rails to prevent static spikes from causing damage to the CMOS multiplexors. In addition, there is a simple resistor-capacitor filter with a corner frequency of approximately 340kHz to remove any unwanted high frequency interference from the signal. This uses high quality WIMA polypropylene capacitors for the best possible performance.

Z104 (left) and **Z105** (right) are the main input multiplexers, which are configured in a "virtual earth" unity gain arrangement with **Z115** and **Z116**. This is an inverting circuit topology and the phase is corrected by the inverting volume control.

Z115B (left) and **Z116B** (right) are the integrating servos, which remove any D.C coefficient from the Analogue input switching stages before the signal is passed onto the following stages, **R180** and **C147** (left) form a filter to remove any broadband noise from the servo output and to improve the speed response.

Z100 – **Z103** are the Tape output selectors these are non-inverting and the outputs are again buffered by **Z9** a/b and **Z10** a/b before arriving at the two tape loop outputs.

Z106 is configured as a double pole changeover switch and is used to select the tone controls or direct by pass mode. (See below for more information).

Tone controls

The tone control stage is non-inverting and uses a gyrating bell filter for the Bass and a simple shelving filter for the high frequencies, the left channel only will be described.

The input is attenuated by -6dB and biased to a voltage of +2.5v D.C by **C111, R113, R112, R110, R111** and **C110**. This is so the signals fall within the 0 – 5v D.C required by the digital potentiometer **Z108**.

Z111B and its associated components form an active equivalent of a series resonant LCR circuit. This has an impedance minimum 5.4k at around 80.

The digital pots **Z108D** and **Z108A** control the bass and treble respectively, this accomplished by moving the wiper connected to the frequency-sensitive impedance between to non inverting and inverting terminals of **Z112A**, effectively changing the ratio of feedback boost and feed forward attenuation of the circuit at the desired frequencies, thus providing a EQ gain control that is on a logarithmic scale, with the use of a linear pot.

Z112B provides the 6dB of gain necessary to bring the nominal level of signal back to unity **C116** and **C117** remove the 2.5VDC offset from the output to prevent click and bangs when the tone control are activated.

Z108 is controlled by a simple 3-wire serial interface from the microprocessor. Each of the digital lines has it's own ground return these are terminated at the GND pin of the chip to minimize any electromagnetic interference.

Volume control

Z107 is a VSDVC electronic volume control IC. It works in conjunction with external op-amp **Z117a/b** by varying the feed-forward and feedback resistors in an inverting gain configuration, the volume control is driven by 3-wire data from the H8 micro on the display board – if the control receives no data it will remain in Audio mute mode.

Relay RLY100 shunts the output of the Op-amps to ground at switch on – power down and when switching between inputs.

Audio output stages.

The Audio output stage contains the buffered, un-buffered and balanced outputs as well as the headphone driver.

The audio signal from the preamp PCB enters the board on **CON100** and the direct signal goes straight to the output via the mute relays **RIY100A** and **RLY101B**. A buffered version of the signal is created by **IC100** and **IC101**. IC100 and IC101 are op-amps configured as unity gain non-inverting buffers.

The C30 also has a Balance XLR output stage that drives into the balanced line drivers **IC103** and **IC104**. These line drivers create a transformer-less balanced output.

Headphone Output.

The selected audio output signal is driven into the headphone driver **IC102**; this signal then passes through **CON101** and **CON102** to the headphone socket **SKT101**. The mute signal passes through the switch contacts in the headphone socket so when headphones are inserted the main outputs are relay muted.

Please note: this means that if the headphone sockets control contacts are faulty or damaged the unit will be permanently stuck in audio mute mode.

RC5 remote code assignment change.

The C30 has the ability to switch between RC5 system code 16* and 19, we can achieve this by pressing and holding the Phono/Aux – CD and AV – DVD buttons simultaneously the display will show.

RC5 System Code 16*

We can toggle the system code using the rotary encoder.

Display board

The display board is very similar in design to the board that has been used for many years in the A85 family of products inc FMJ A32 and as such those of you familiar with these products will know there way around this board, a full description follows.

The power supply rails for the display board are derived from the main board we should expect to see the below supplies in place (Fig 2.)

Fig 2 Display board power supply pins

Power supply	Pin number of SK1
+ 5v D.C (micro)	Pin 14
+ 5v D.C	Pin 1
+ 46v D.C for VFD HT	Pin 3

Please note: the H8 micro is very critical of the +5v supply and as such the unit may crash or fail to power up during use if the +5v supply drops below 4.5v.

H8 Microprocessor

The **H8** micro at location **Z1** is pre-programmed by Arcam using a flash-programming module and cannot be reprogrammed in the field unless you have access to the appropriate hardware and software.

The **H8** forms the heart of the C30 and takes on all major control functions including.

1. **Control of the input switching.**
2. **Controls the action of the volume cont.**
3. **Monitors protection status and mute lines A85/A90/A32 only.**
4. **Sends display information to the VFD.**
5. **Receives and decodes RC5 data.**
6. **Receives data from rear panel remote input.**
7. **Stores setting information via 24C02 E-prom.**

At initial power up the H8 micro is reset by **Z2** a **DS1233** econo reset package.

The input switching information is driven out to the Pre-amp card via the 9 select lines that appear on Pins 14 – 22 of **SK3**.

The Volume control and tone control circuits are driven from the **SDATA – SLOAD** and **SCLK** data lines from SK3.

The **Mute** status line has control over the pre-amp output relay at location **RLY100**; the mute is triggered during power up/down and between input selections and under Mute commands.

Within the C30 the **DC prot, Therm, VI prot** and **SP1/SP2** control lines are all connected to Digital ground on the main board of the pre-amp as these are not required within this product.

The H8 drives the **VFD** via 4 Data lines that can be seen on R64 – R67 as **DISPDAT, DISPCLK, DISPBLK, DISPLAT** these drive directly into the VFD.

Remote Data can be received by the C30 via the 3.5 mm Phono jack on the rear of the Pre-amp and the previously described remote demodulator on the main board this demodulated RC5 arrives on the display board via **Pin 3** of **SK1** and goes into a common IR input pin of the H8 micro (**pin 87**) this pin is also used to pick the RC5 code up from the Display onboard remote receiver.

At power up the H8 reads all previously stored and last settings used by the amplifier from the e-eprom at location IC5 these will include the last input used and tape settings also tone control and input level settings, any changes to the set-up of the amplifier are sent to the e-eprom for future recall, at power down the H8 downloads it's settings to the e-eprom.

All indication LED's are driven directly from the H8 micro, these LED's are tagged onto the +5v rail via 10k current limiting resistors Q1 and Q2 form a toggle between Green and Red for the standby/power LED.

The volume control is driven from a Rotary encoder at location **SW18** the toggle lines from the encoder arrive at the H8 as control lines Phase A and Phase B on **Pins 93** and **94**.

Multi channel input module (optional)

Introduction

The multi input module an optional expansion board that allows the existing Amp/Pre-amp to become part of a surround system when driven by a DVD/SACD player with Analogue surround outputs.

The board has two sets of 7.1 input (8 channels) these are labelled as MCH1 and MCH2 and accept Left, Right, Centre, Left surround, Right surround, Left Back, Right back audio Information.

All input channel levels can be trimmed levels to allow for system balancing.

Put very simply this is an eight-channel preamplifier.

Power supply

The board is powered from the +/- 15v supply on the existing pre-amp board on board regulators REG100 and REG101 regulate these rails down to -5v and +5v respectively.

The digital sections of the circuit are powered by a single +5v rail this is isolated from the main 5v rail via inductor L100.

Capacitors C100, C101 and C105, C107 act as bulk charge stores to prevent current surges from affecting the main pre-amp stage power supply stages.

Micro Processor

The micro controller operates from a **4 Mhz** crystal and is in control of all of the board's function via its input/output ports.

The micro controller is reset on power up via **R/C** network **R101** and **C120**. The micro controller stays in reset condition for approximately **500ms** this allows the host micro controller (H8 Z1 on display board) to initialize and for the power supplies to settle.

The Host micro communicates with the onboard micro via CON 101. Three lines are

used for communication these are seen on the circuit diagram as PB0, receive from ExpBrd and Transmit to ExpBrd.

When the host is communicating with the onboard micro controller PB0 will be driven low, otherwise the Data sent will be ignored.

Input switching

The input allow for the signal routing of the eight channels from either of the inputs these are **MCH1** and **MCH2**, select lines **S1-S2-S3** are used to select each bank of inputs this inputs stage utilizes **6 x 74HCT4053** multiplexers you will notice that IC204 and **IC205** only utilize the **S1** and **S2** select channels as this input switch only deals with two channels (Back left and Back right).

Please note: The software will only allow one set of inputs to be selected at any one time.

The outputs of the input multiplexers drive into a group of **8 line drive Op-Amps** (IC300-IC307) these are configured two pole integrating D.C servo before reaching the Volume control stages.

Volume control

Volume control is performed by two channel **Burr-Brown PGA2310** volume control chips. The gain is under micro control with steps of 0.5dB.

All volume control chips share **Data**, **Clock** and **Mute** control but have Chip select lines that are grouped in the following way Front Right, Front Left, Centre and Sub share the same select line, and the remaining channels share a chip select line (Surround right and Left, Back right and Left). The volume of each channel can be controlled individually "trimmed".

If a loud clicking is heard on a individual channel whilst adjusting the volume it is probably the input stage that is at fault and not the volume control chip itself, the input stage should prevent D.C levels form entering the volume control.

Output driver stage

The output driver stage consists of four **OPA2134** dual channel Op-Amps (**IC400-IC403**) each output for instance Front left channel takes one channel of the op-amp.

The front left and front right channels are driven down into the Pre-amp board via Pins 1 and 2 of connector Con400 and is fed into the input switches of the Pre-amp boards multiplex on Pin 9 from this point the signal is dealt with as a normal signal input into the Pre-amp.

Please note: the left and right signals are seen on the L937 pre-amp card circuit diagrams as module left and module right.

The Remaining channels are rail clamped to remove any over-voltage spikes from the rails and to prevent damage to ancillary equipment using diode packages **D400 – D405**.

Each output has a mute relay that when engaged shunts the output to ground at power up and power down preventing any spurious D.C levels from leaving the card.

Simplified Block Diagram

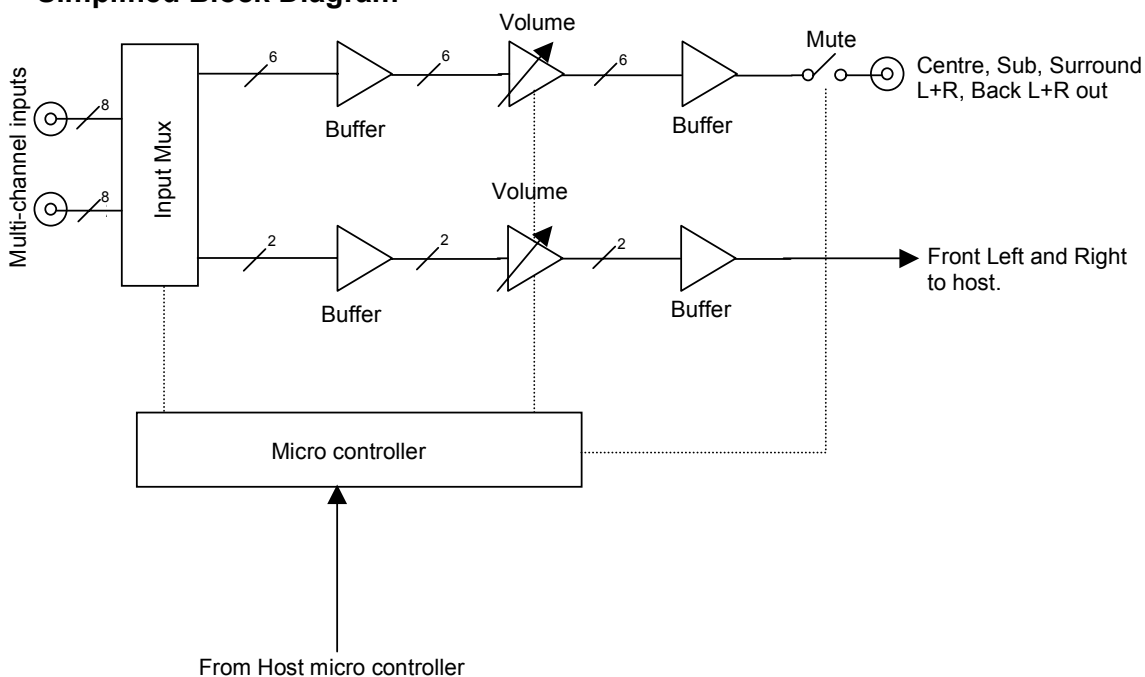

Phono stage

The Phono board is a simple single stage RIAA amplifier. It consists of two channels of high gain amplification, and switching between moving magnet (MM) and moving coil (MC) settings.

PSU:

The unit derives its $\pm 15V$ regulated rails from the unit it is fitted into with only local decoupling capacitors on board.

Interface:

The unit connects to the host unit via a 8 way connector:

Amplifier:

The left channel has designators beginning with 100, and the right with 200. For the purposes of this description the left channel will be described, as the right channel the same in all respects.

The amplifier is a small signal class A voltage feedback amplifier with switchable gain. The input consists of an actively loaded differential pair of very low noise PNP transistors (**TR106, 107**). These transistors are very specific and should only be replaced with identical parts with the E grade high gain. **TR100 & TR101** form a current source for the pair, which sets the quiescent current for the entire amplifier. The active load consists of **TR110 & TR111**, which forms part of a differential current mirror with **TR112, 113 & 114**. This differential stage also has an active load (**TR102 & TR103**) to keep gain to a maximum.

Both of these differential stages are designed to have as much gain as possible to enable the single stage design. The RIAA response is achieved in the feedback network: **C101,110,111,112,119,120,&R115,112**. **C115** is used to correct between MM & MC gains as the amplifier is non-inverting.

SW100 switches between MM & MC. Two poles of the switch change between the different loading required for each type of cartridge: **R108 & C109** for MM, and added in parallel for MC **R104 & C108**. The other two poles change the feedback resistor value to alter the gain. MM: R105 and in parallel for MC R123.

The DC offset is controlled by a non-inverting servo built around IC100. The amount of servo current is different for each gain setting via **R111** (MM) & **R124** (MC) so that the low frequency high pass point remains the same for both settings. However the high pass point for the circuit is set by C113. This gives a warp filter, stops DC startup thumps from upsetting DC coupled circuitry and an approximation of the RIAA/IEC curve (-2dB @ 20Hz).

The output is class A buffered by a dual mirror follower (**TR104, 105, 108, 109**). The quiescent current is set up by D100 and R118, 119.

Closed loop stability is achieved with **C116, 117** giving symmetrical slewing capability.

PSU and Control Circuit
L958CT1_1.4_PSU and Control New Demod.Sch



Audio Circuit
L958CT2_1.4_Audio1.Sch



ITEM	QTY	PART No.	DESCRIPTION	NOTES
ITEM1	1	L958PB	Blank PCB C30 Preamp PSU	
ITEM2	1	F006	Clip For SW Profile Heatsink	Clip for HS1
ITEM3	1	F006	Clip For SW Profile Heatsink	Clip for HS2
ITEM4	1	F006	Clip For SW Profile Heatsink	Clip for HS3
ITEM6	1	F006	Clip For SW Profile Heatsink	Clip for HS5
ITEM7	1	F006	Clip For SW Profile Heatsink	Clip for HS6
ITEM8	1	E802AP	Pad Damping 15x6x3MM Sorbothane	PIECE SHARED BETWEEN C21, C22 (SEE ASSY DWG)
ITEM9	1	E826AP	Pad Damping 7.5x6x3 Sorbothane	PLACE ON RLY100
ITEM10	1	E826AP	Pad Damping 7.5x6x3 Sorbothane	PLACE ON RLY101
ITEM11	1	E826AP	Pad Damping 7.5x6x3 Sorbothane	PLACE ON RLY102
ITEM12	1	E826AP	Pad Damping 7.5x6x3 Sorbothane	PLACE ON RLY103
ITEM13	1	F022	Fuseholder Cover For 20mm Fuseholder	
ITEM14	1	F022	Fuseholder Cover For 20mm Fuseholder	
ITEM15	1	F022	Fuseholder Cover For 20mm Fuseholder	
ITEM16	1	F022	Fuseholder Cover For 20mm Fuseholder	
ITEM17	1	8M101	Earth Lead Assy 75MM	SOLDER TO TAB ON SKT1

FIX1



Dia 3.2mm

FIX2



Dia 3.2mm

FIX3

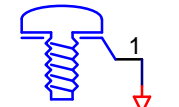

Dia 3.5mm

FIX4

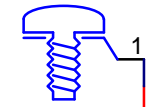

Dia 3.5mm

FIX5



Dia 3.5mm

FIX6



Dia 3.5mm

FIX7



Dia 3.5mm

FIX8



Dia 3.5mm

FIX9



Dia 3.5mm

FIX10



Dia 3.5mm

FIX11



Dia 3.5mm

FIX12



Dia 3.5mm

FIX13

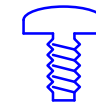

Dia 3.5mm

- FD1
- FD2
- FD3
- FD4

- TOOL1
- TOOL2
- TOOL3
- TOOL4

DRAWING TITLE C30 Preamp	03_E215	KAL	15/07/03	R1 changed to VR37	1.4	
	03_E191	AJD	27/06/03	RC5 remote bus demod fix	1.3	
23425 A & R Cambridge Ltd. Pembroke Avenue Waterbeach Cambridge CB5 9PB	Filename: L958CT0_1.4_Top Level.Prj	03_E186	KAL	21/06/03	Renumbered Sorbothane	1.2
	Notes:	03_E172	AJD	06/06/03	Mods following listening test. Sorbothane and some caps	1.1
		03_E119	MJT	17/04/03	Production release	1.0
		ECO No.	INITIALS	DATE	DESCRIPTION OF CHANGE	ISSUE
Contact Engineer: Kevin Lamb	Contact Tel: (01223) 203200	Printed: 15-Jul-2003	Sheet 1 of 1	DRAWING NO. L958CT0		

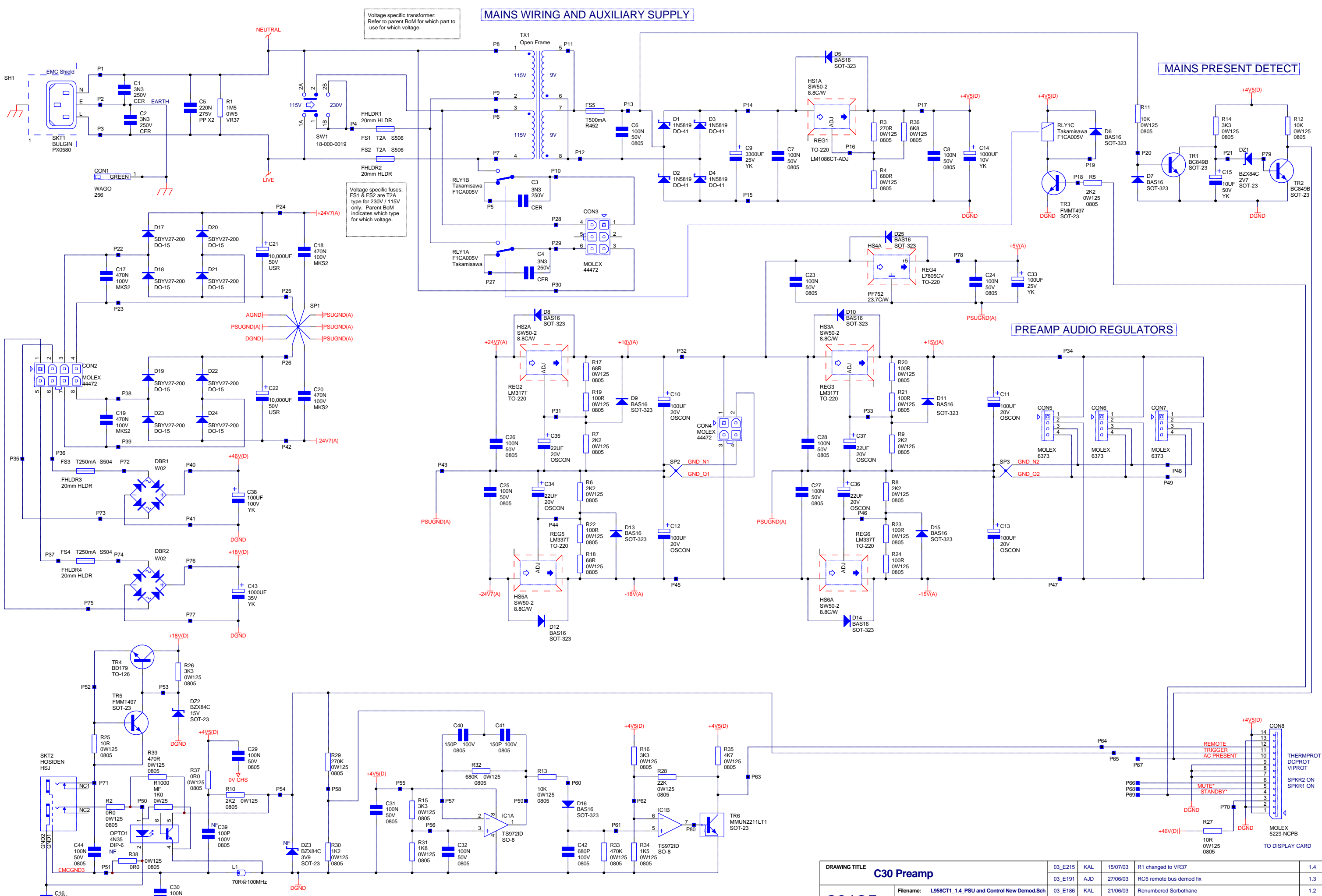

Voltage specific transformer:
Refer to parent BoM for which part to use for which voltage.

Voltage specific fuses:
FS1 & FS2 are T2A type for 230V / 115V only. Parent BoM indicates which type for which voltage.

DRAWING TITLE		303_E215		KAL		15/07/03		R1 changed to VR37		1.4	
303_E191		AJD		27/06/03		RC5 remote bus demod fix				1.3	
303_E186		KAL		21/06/03		Renumbered Sorbothane				1.2	
303_E172		AJD		06/06/03		Mods following listening test. Sorbothane and some caps				1.1	
303_E119		MJT		17/04/03		Production release				1.0	
ECO No.		INITIALS		DATE		DESCRIPTION OF CHANGE				ISSUE	
23425		A & R Cambridge Ltd. Pembroke Avenue Waterbeach Cambridge CB5 9PB		Contact Engineer: Kevin Lamb		Contact Tel: (01223) 203200		Printed: 15-Jul-2003		Sheet 2 of 3	
										DRAWING NO. L958CT1	

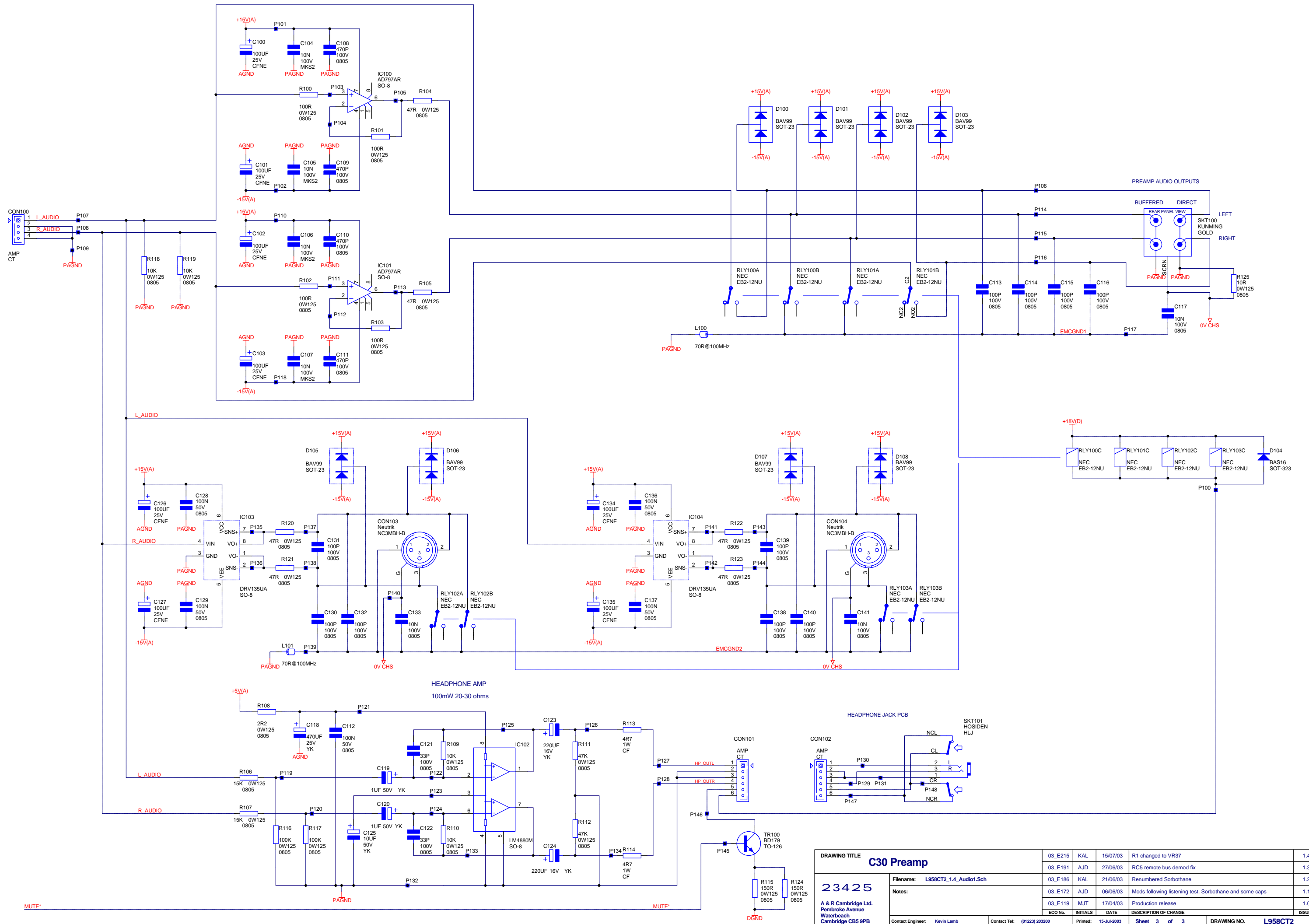

DRAWING TITLE		C30 Preamp			
03_E215	KAL	15/07/03	R1 changed to VR37	1.4	
03_E191	AJD	27/06/03	RCS remote bus demod fix	1.3	
03_E186	KAL	21/06/03	Renumbered Sorbothane	1.2	
03_E172	AJD	06/06/03	Mods following listening test. Sorbothane and some caps	1.1	
03_E119	MJT	17/04/03	Production release	1.0	
ECO No.	INITIALS	DATE	DESCRIPTION OF CHANGE	ISSUE	
A & R Cambridge Ltd. Pembroke Avenue Waterbeach Cambridge CB5 9PB		Contact Engineer: Kevin Lamb	Contact Tel: (01223) 203200	Printed: 15-Jul-2003	Sheet 3 of 3
DRAWING NO. L958CT2					

Main signal path
L965C2_1.2.SCH



Power supply
L965C3_1.2.SCH



PCB1

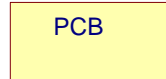

L937PB_1

DRAWING TITLE		C30 Preamp PCB						
ARCAM A & R Cambridge Ltd. Pembroke Avenue Waterbeach Cambridge CB5 9PB	Filename: L965C1_1.2.PRJ	03_E291	MJT	10/10/03	None to this sheet. Transistors Q301 & Q305 obsolete. Replaced by 4B5171 and 4B1930 respectively	1.2		
	Notes:	03_E221	KAL	18/07/03	Added sorbothane, changed 470pF FKP2 and 100uF Oscon part no	1.1		
		03_E156	KAL	02/06/03	Assy created from L937, various capacitors and sorbothane changed	1.0		
		ECO No.	INITIALS	DATE	DESCRIPTION OF CHANGE	ISSUE		
Contact Engineer: Kevin Lamb	Contact Tel: (01223) 203243	Printed: 10-Oct-2003	Sheet 1 of 3		A4	DRAWING NO. L965C1		

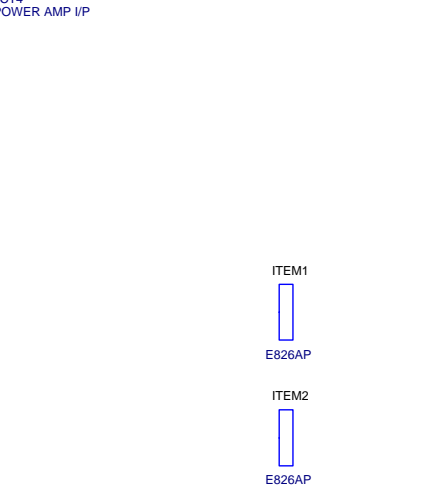
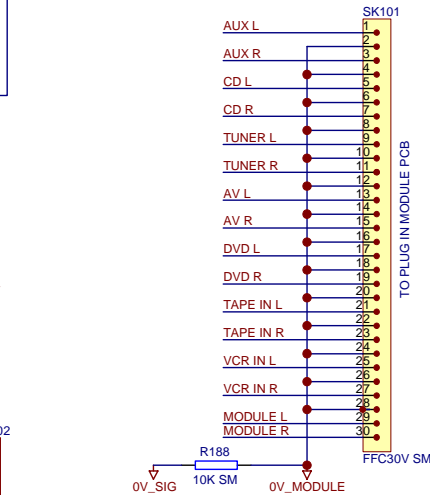
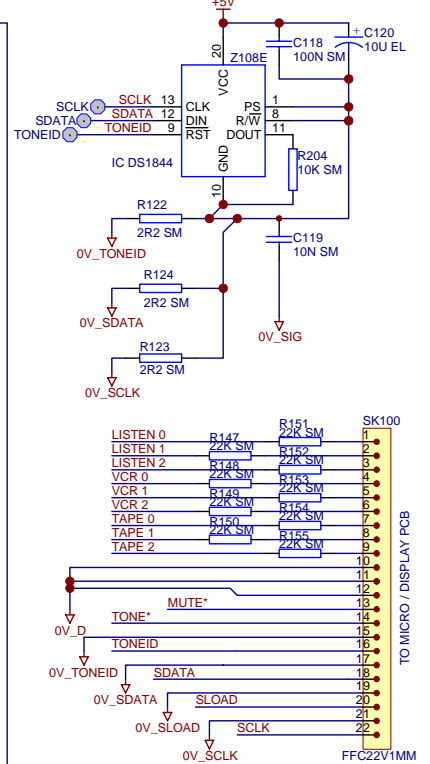
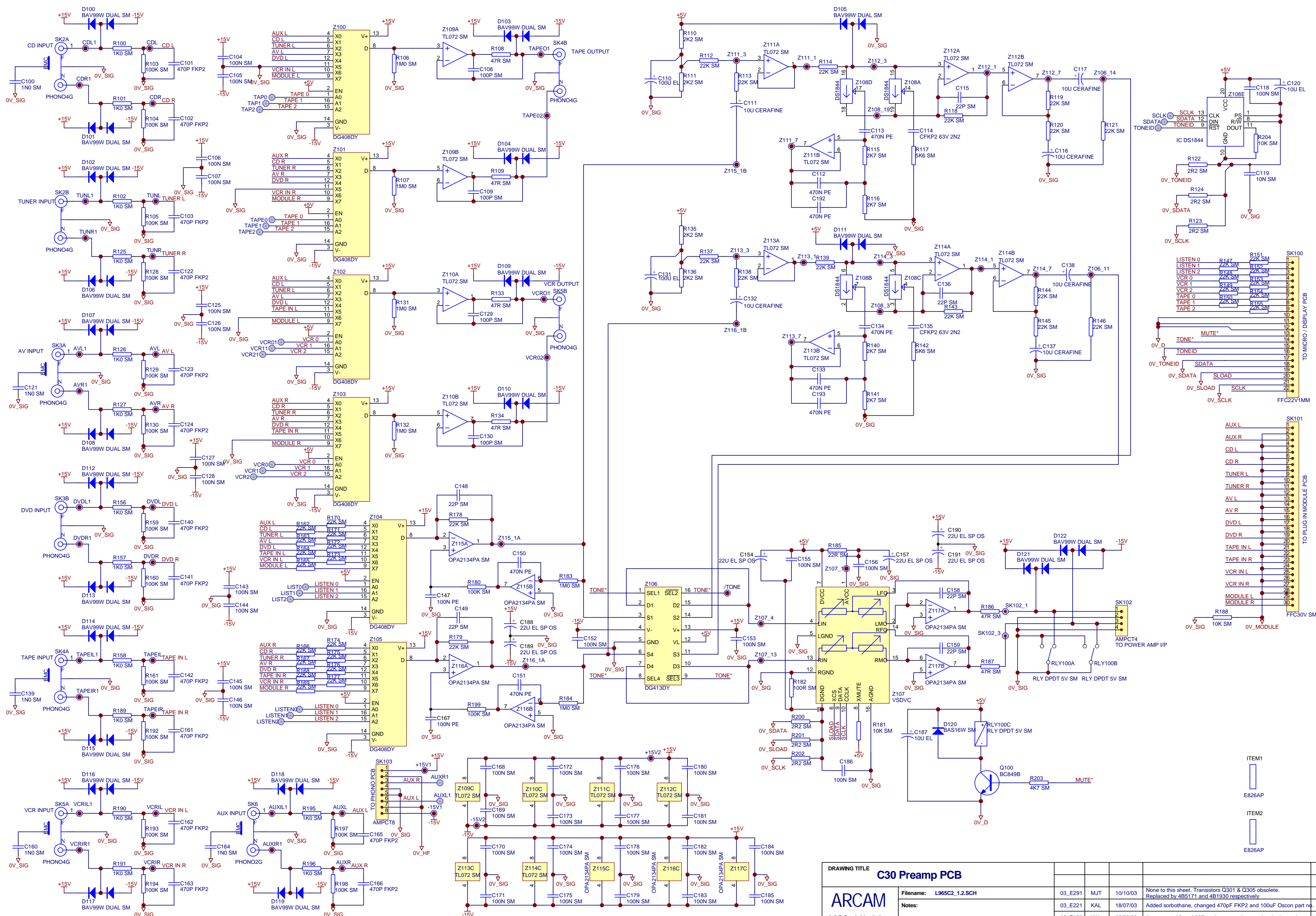

DRAWING TITLE C30 Preamp PCB

ARCAM

File name: L965C2_1.2.SCH

A & R Cambridge Ltd.
Pembroke Avenue
Waterbeach
Cambridge CB5 9PB

ECO No.	INITIALS	DATE	DESCRIPTION OF CHANGE	ISSUE
03_E291	MJT	10/10/03	None to this sheet. Transistors Q301 & Q305 obsolete. Replaced by 4B5171 and 4B1930 respectively.	1.2
03_E221	KAL	18/07/03	Added sorbothane, changed 470pF FKP2 and 100uF Oscon part no.	1.1
03_E156	KAL	02/06/03	Assy created from L937, various capacitors and sorbothane changed 1.0	1.0

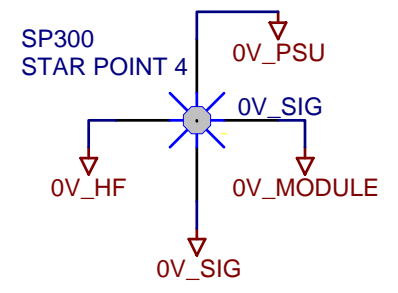
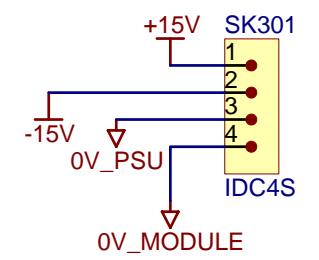
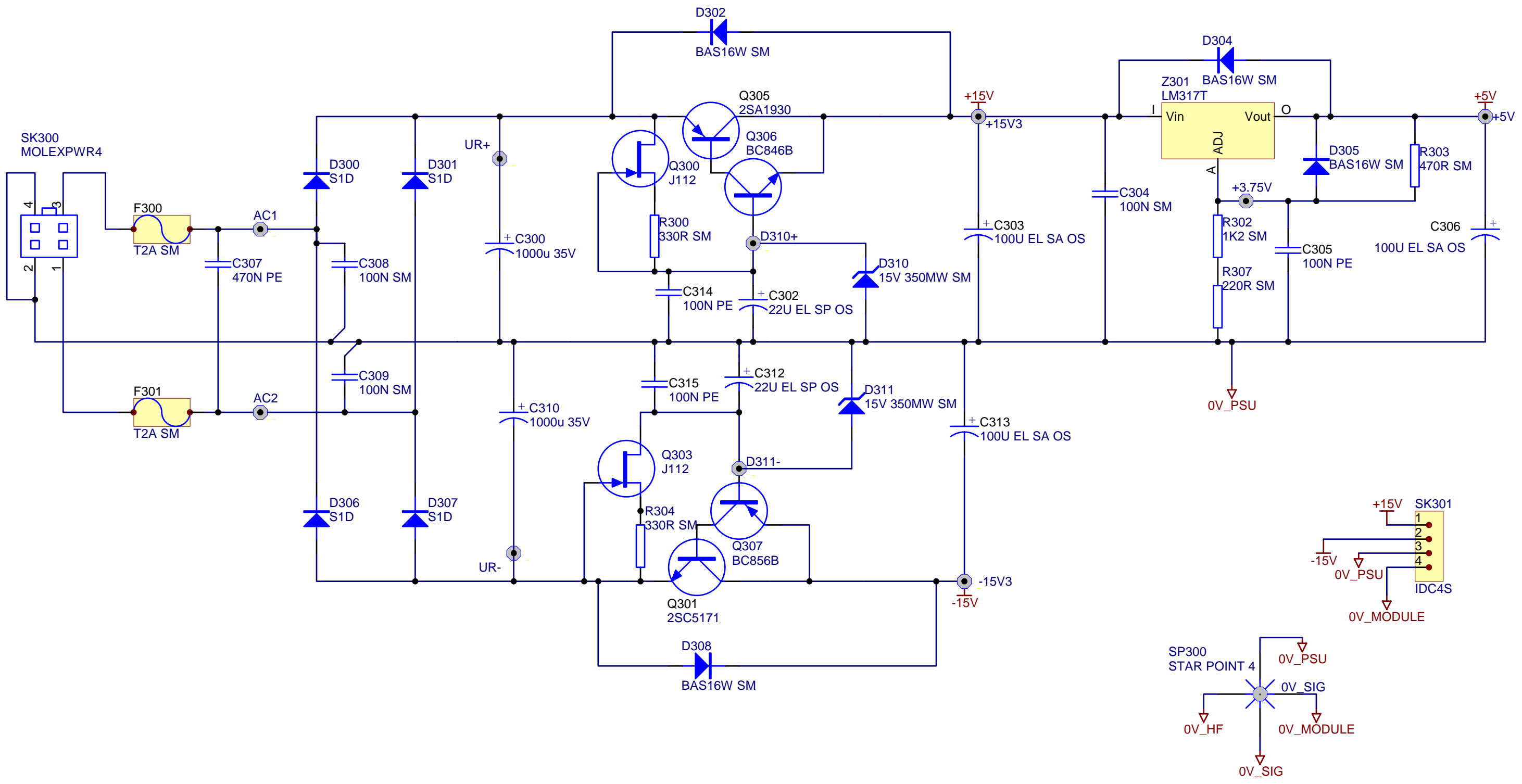

DRAWING TITLE								
C30 Preamp PCB								
ARCAM A & R Cambridge Ltd. Pembroke Avenue Waterbeach Cambridge CB5 9PB	Filename:	L965C3_1.2.SCH	03_E291	MJT	10/10/03	Transistors Q301 & Q305 obsolete. Replaced by 4B5171 and 4B1930 respectively	1.2	
	Notes:		03_E221	KAL	18/07/03	Added sorbothane, changed 470pF FKP2 and 100uF Oscon part no	1.1	
			03_E156	KAL	02/06/03	Assy created from L937, various capacitors and sorbothane changed	1.0	
	ECO No.	INITIALS	DATE	DESCRIPTION OF CHANGE		ISSUE		
	Contact Engineer:	Kevin Lamb	Contact Tel:	(01223) 203243	Printed:	10-Oct-2003	Sheet 3 of 3	A4

A32 FMJ DISPLAY PCB

L928CT_B.1
L928CT_2_B.3.SCH

MICRO

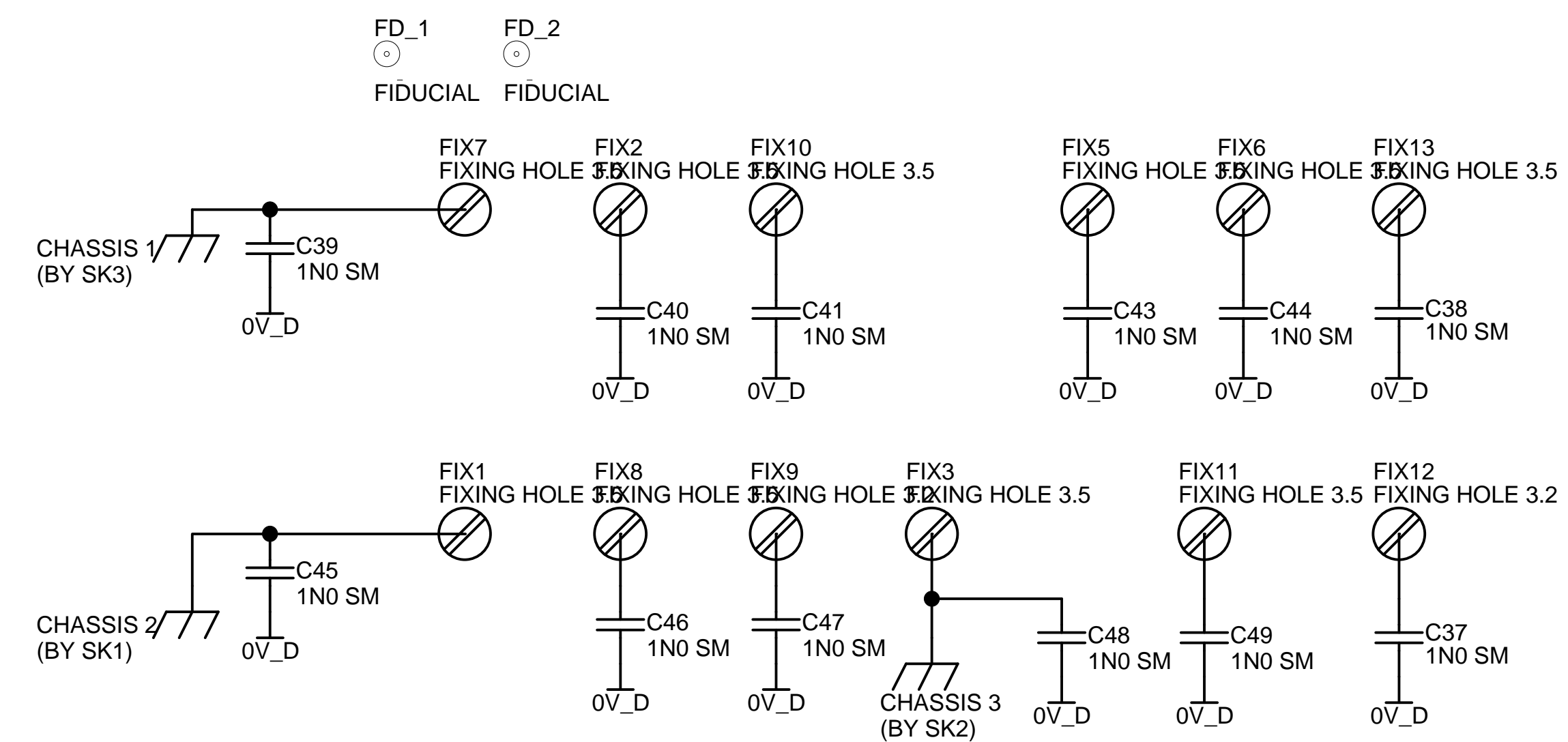

PCB1
PCB
L928PB_B

please remove F163 sticky pads
they should not be on here

DRAWING TITLE A32 FMJ AMP DISPLAY PCB		WAF	26/9/01	STICKY PADS RENUMBERED	B.3	
23425 A & R Cambridge Ltd. Pembroke Avenue Denny Industrial Centre Waterbeach Cambridge CB5 9PB	Circuit Diagram		JBR	10/9/01	PRE PRODUCTION RELEASE	B.2
	Notes:	WAF	9/08/01	UPDATED PROTOTYPE	B.0	
	ECO No.	INITIALS	DATE	DESCRIPTION OF CHANGE	ISSUE	
Filename J:\Released_Documents\Native_format_files\Protel_DDB\L928_B.3.Ddb - Documents\L928CT10-01.P2001	Date Printed 10-09-2001	Drawn by: CL	Sheet 1 of 2	DRAWING NO. L928CT1		

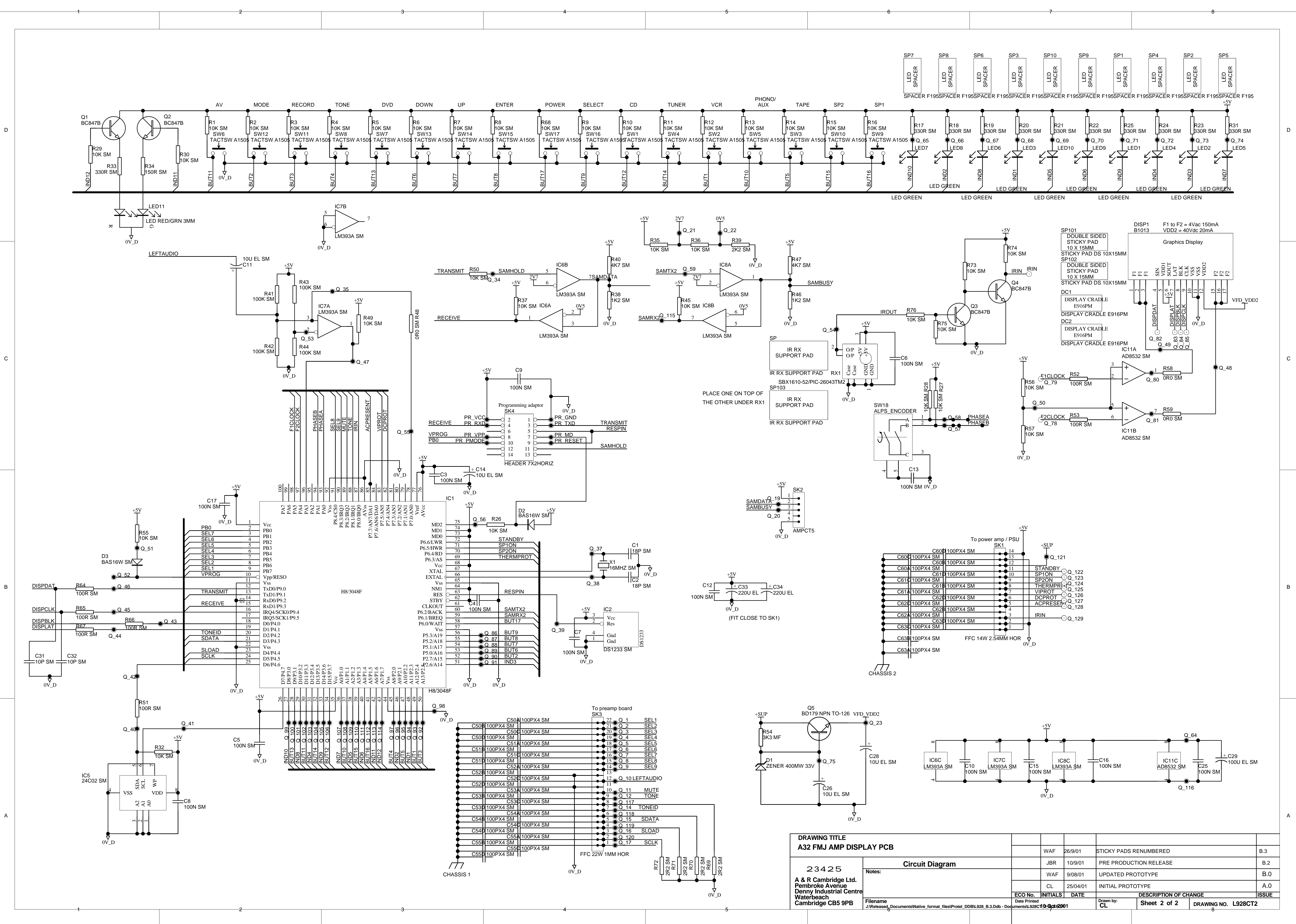

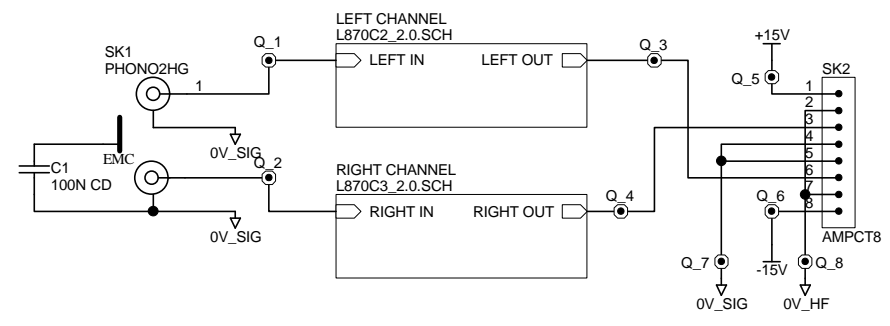

PCB1
PCB
 L870PB_2

EL1
 Update Box
 UPDATE_BOX

DRAWING TITLE A85 PHONO STAGE - TOP LEVEL										
23425 A & R Cambridge Ltd. Pembroke Avenue Denny Industrial Centre Waterbeach Cambridge CB5 9PB						Circuit Diagram				
Notes:						01_1070	JAG	17/4/01	updated pcb and scm	2
Filename G:\DATA\ECO\ECO AGENDA\01_1070\870 A85 PHONO ISSUE2\L870 2.0.ddb - L870c1 2.0.PRJ						00_1051	JAG	22/3/01	PRODUCTION ISSUE	1
Date Printed 23-Apr-2001						ECO No.	INITIALS	DATE	DESCRIPTION OF CHANGE	ISSUE
Date Drawn 23-Apr-2001						Drawn by: JBR	Sheet 1 of 3		DRAWING NO. L870C1	

ITEM	QTY	PART No.	DESCRIPTION	NOTES
ITEM100	1	L955PB	BLANK PCB 7.1 MCH PCB	
ITEM101	1	E802AP	PAD DAMPING 15x6x3MM SORBOTHANE	Fit on top of IC308
ITEM102	1	E802AP	PAD DAMPING 15x6x3MM SORBOTHANE	Fit on top of IC309
ITEM103	1	E802AP	PAD DAMPING 15x6x3MM SORBOTHANE	Fit on top of IC310
ITEM104	1	E802AP	PAD DAMPING 15x6x3MM SORBOTHANE	Fit on top of IC311
ITEM105	1	E802AP	PAD DAMPING 15x6x3MM SORBOTHANE	Fit on top of C100 and C101

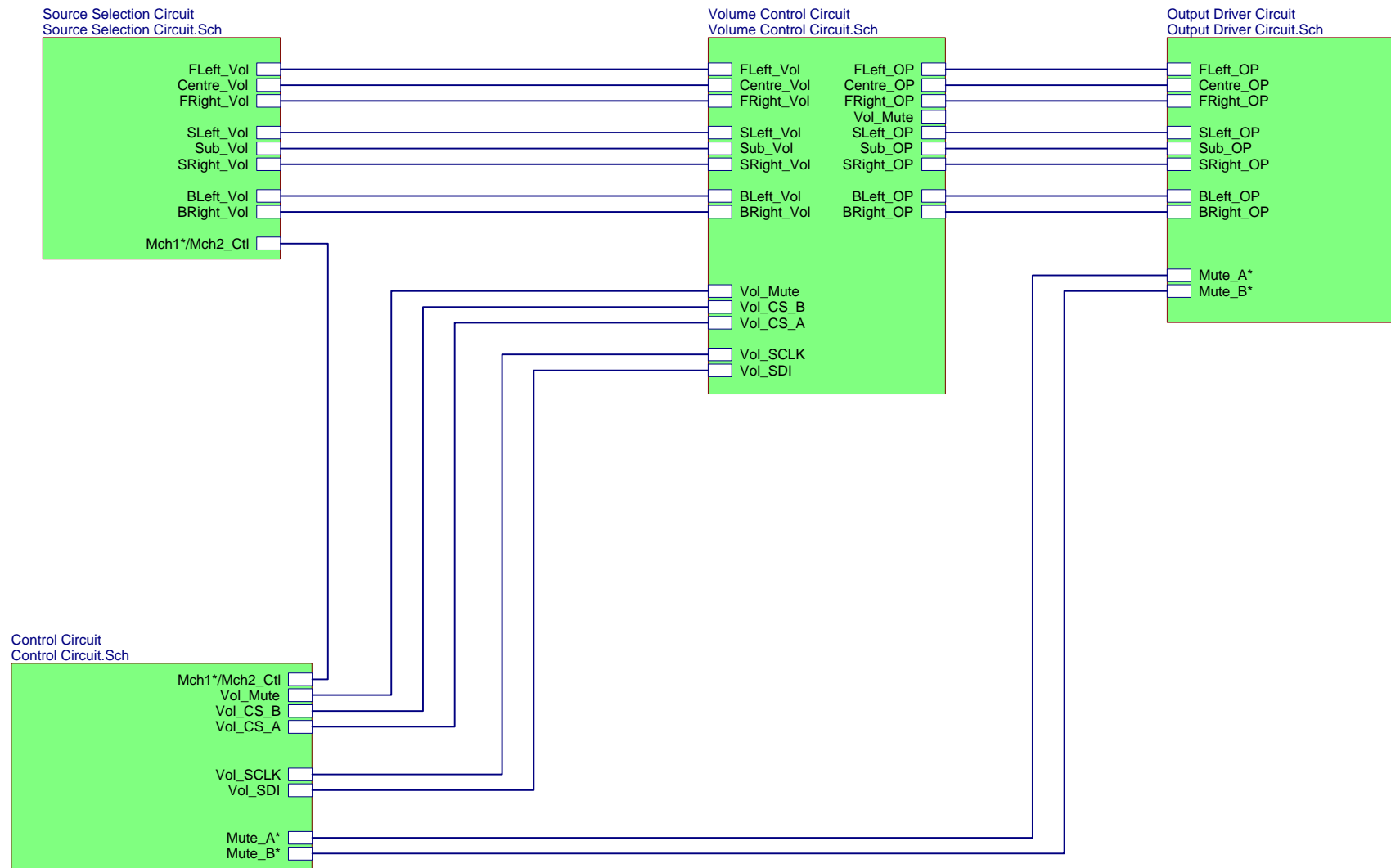

DRAWING TITLE							
Top Sheet							
23425 A & R Cambridge Ltd. Pembroke Avenue Waterbeach Cambridge CB5 9PB	Filename: expansion brd.prj	03_E095	S.U	03/04/03	ISSUE 1 Release	1.0	
	Notes: A80/A32 Multichannel Expansion Module	03_E071	S.U	03/03/03	ISSUE B Release	B	
		02_E227	S.U	16/10/02	ISSUE A Release	A	
	Contact Engineer: Sandip Ukani	Contact Tel: (01223) 203293	Printed: 4-Apr-2003	Sheet 0 of 4	DRAWING NO. L955CT		

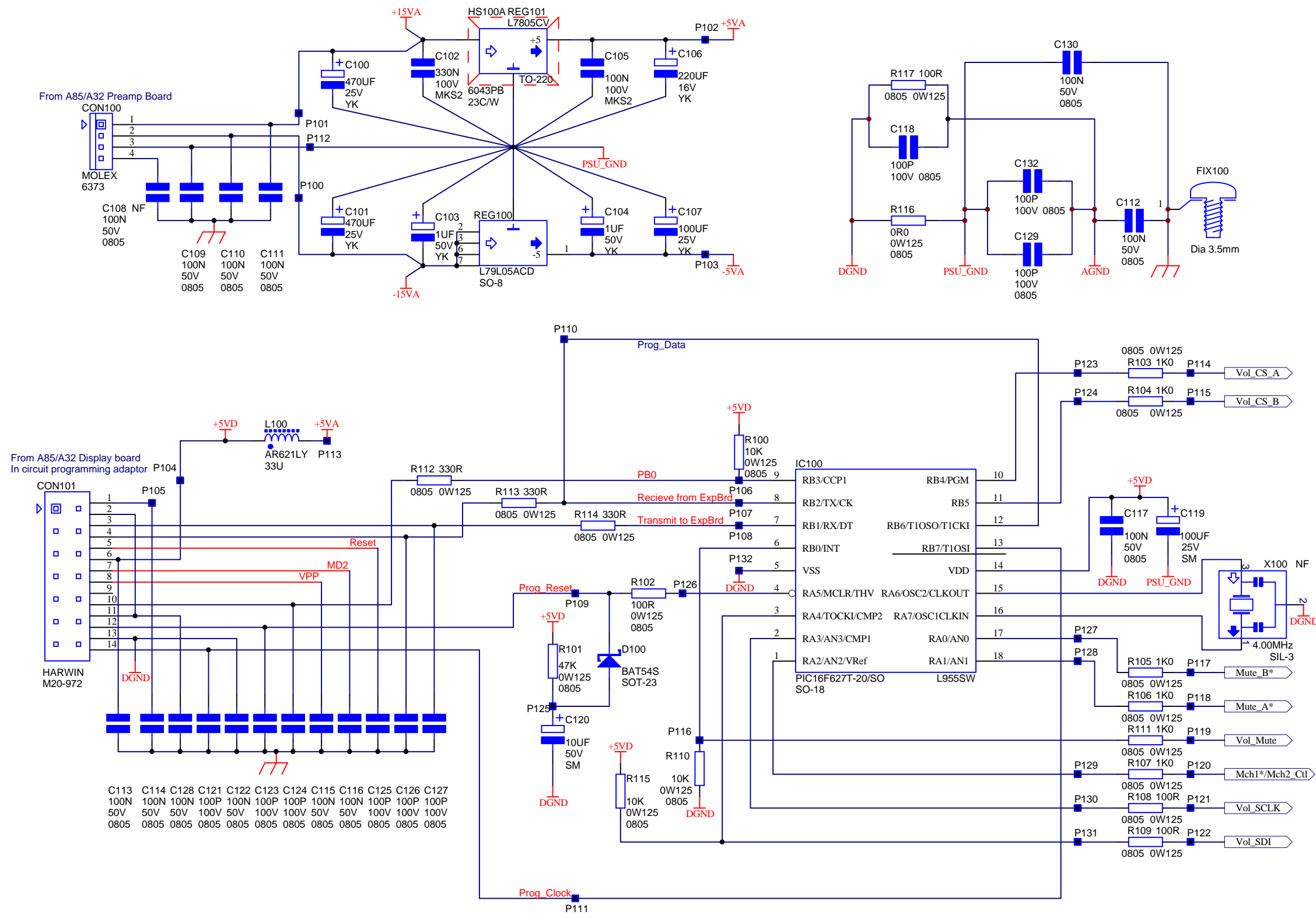

DRAWING TITLE							
Control, Power and Interface							
23425 A & R Cambridge Ltd. Pembroke Avenue Waterbeach Cambridge CB5 9PB	Filename:	Control Circuit.Sch	03_E095	S.U	03/04/03	ISSUE 1 Release	1.0
	Notes:	A80/A32 Multichannel Expansion Module	03_E071	S.U	03/03/03	ISSUE B Release	B
			02_E227	S.U	16/10/02	ISSUE A Release	A
	ECO No.	INITIALS	DATE	DESCRIPTION OF CHANGE		ISSUE	
Contact Engineer:	Sandip Ukani	Contact Tel:	(01223) 203293	Printed:	4-Apr-2003	Sheet 1 of 4	DRAWING NO. L955CT_1

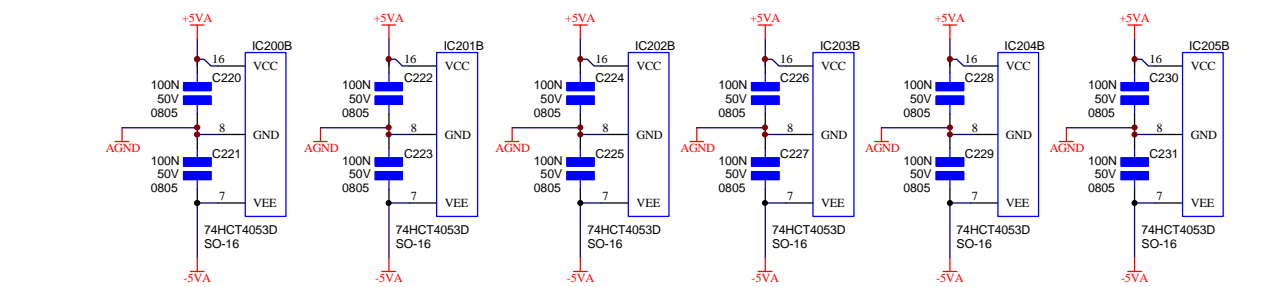
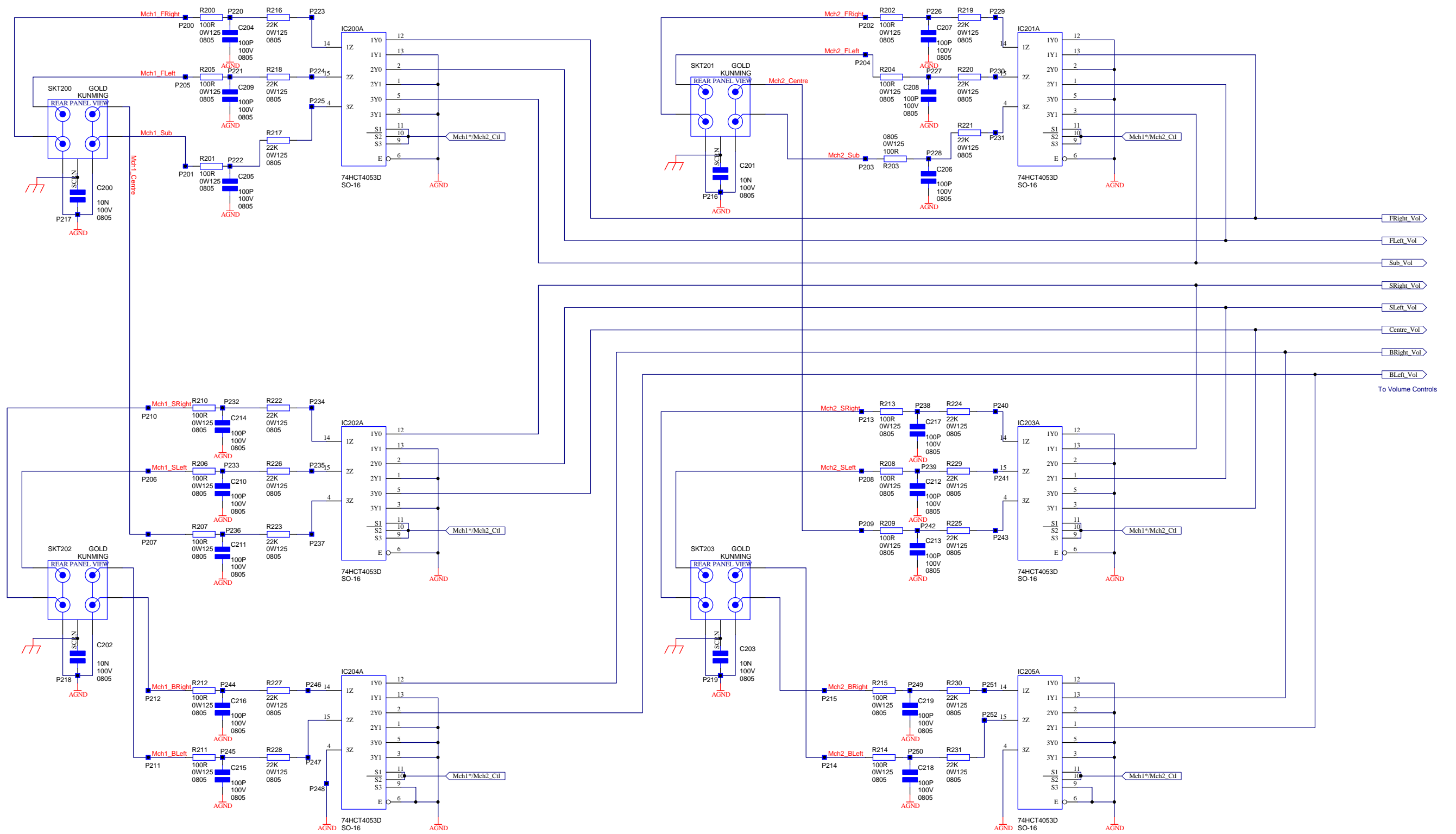

DRAWING TITLE						
Source Multiplexer						
23425	Filename: Source Selection Circuit.Sch	03_E095	S.U	03/04/03	ISSUE 1 Release	1.0
A & R Cambridge Ltd. Pembroke Avenue Waterbeach Cambridge CB5 9PB	Notes: A80/A32 Multichannel Expansion Module	03_E071	S.U	03/03/03	ISSUE B Release	B
		02_E227	S.U	16/10/02	ISSUE A Release	A
		ECO No.	INITIALS	DATE	DESCRIPTION OF CHANGE	ISSUE
Contact Engineer: Sandip Ukani	Contact Tel: (01223) 203293	Printed: 4-Apr-2003	Sheet 2 of 4	DRAWING NO. L955CT_2		

Note: Bulk decoupling capacitors on volume chips also bulk decouple the attached dc servos

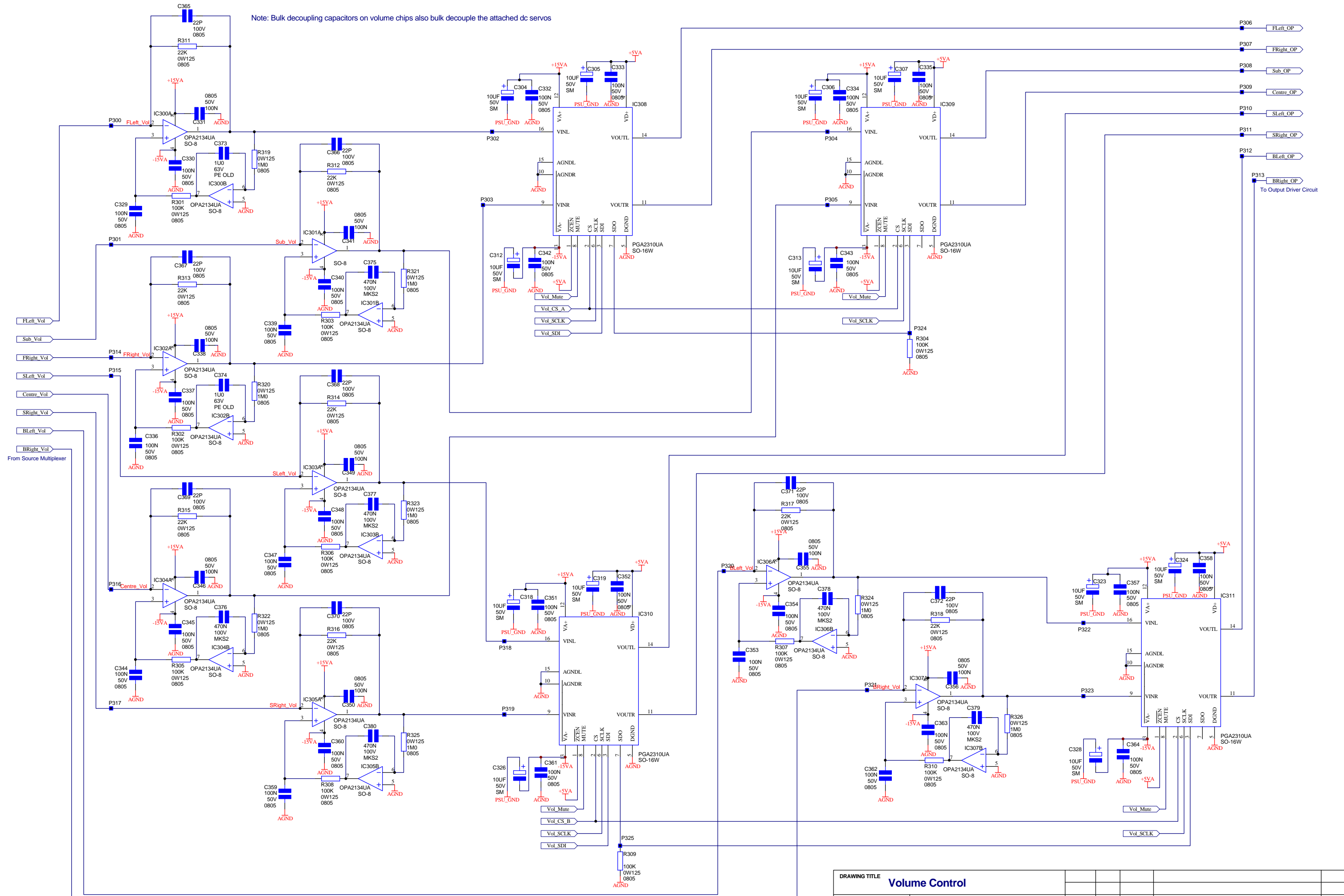

DRAWING TITLE								
Volume Control								
23425		Filename: Volume Control Circuit.Sch						
A & R Cambridge Ltd. Pembroke Avenue Waterbeach Cambridge CB5 9PB		Notes:		03_E071	S.U	03/03/03	ISSUE B Release	B
				02_E227	S.U	16/10/02	ISSUE A Release	A
		ECO No.	INITIALS	DATE	DESCRIPTION OF CHANGE		ISSUE	
Contact Engineer: EngNameXXXX		Contact Tel: (01223) 203XXX tel No		Printed: 4-Apr-2003		Sheet 3 of 4		DRAWING NO. L95CT_3

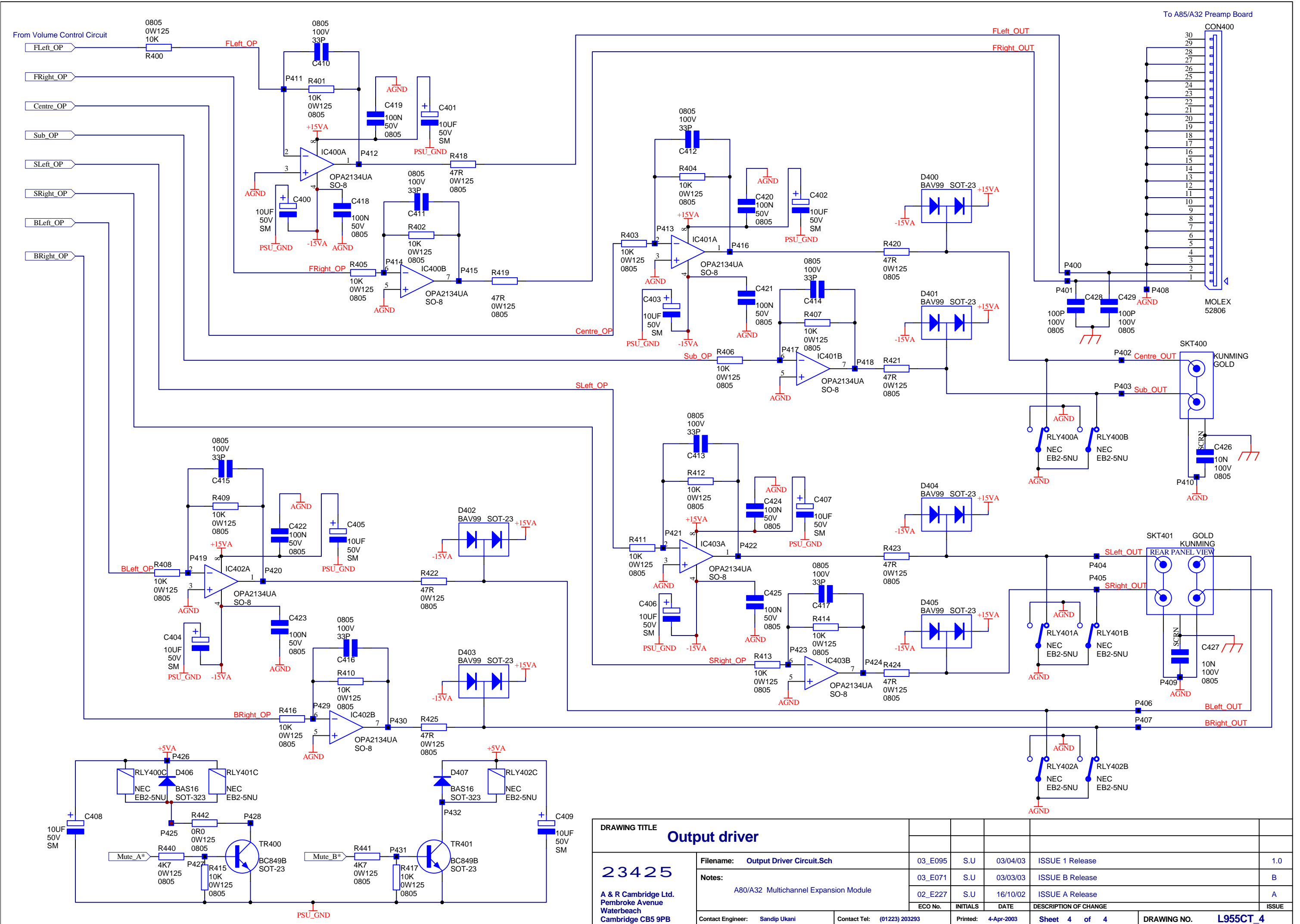

DRAWING TITLE								
Output driver								
23425	Filename:	Output Driver Circuit.Sch	03_E095	S.U	03/04/03	ISSUE 1 Release	1.0	
A & R Cambridge Ltd. Pembroke Avenue Waterbeach Cambridge CB5 9PB	Notes:	A80/A32 Multichannel Expansion Module		03_E071	S.U	03/03/03	ISSUE B Release	B
		02_E227	S.U	16/10/02	ISSUE A Release	A		
		ECO No.	INITIALS	DATE	DESCRIPTION OF CHANGE	ISSUE		
Contact Engineer:	Sandip Ukani	Contact Tel:	(01223) 203293	Printed:	4-Apr-2003	Sheet 4 of 4	DRAWING NO. L955CT_4	

Transformer Specification For 115230V C30 transformer
Acam Part Number L923TX

Material Specification

1. Winding Wire to be Grade 2 (130C rating) to BS 603174:1995
2. Mylar Polyester Insulator 130C Rated
3. Potting Compound PC3602 E13629(M)

Mechanical Specification

1. Middle of transformer to be potted (as shown).
2. Primary windings connect to 6 way MOLEX connector 39401-3035. Secondary windings connect to 8 way MOLEX connector 39401-3038. Use MOLEX pin 44475-3112. MOLEX connectors have pin numbers indicated on them.
3. Primary wires are endzoned in a common sleeve. Secondary wires are endzoned in a common sleeve. Use PVC sleeving.
4. All wire lengths in mm. Lengths are +5.0, -0
5. Please adhere rubber insulating pad to bottom of transformer as shown.

Electrical Specification

1. Transformer to have dual 115V primaries to allow parallel operation for 115V input and series operation with 230V input.
2. Transformer input voltage range
115V -18% +14% (97.5V to 132.5V)
230V -18% +14% (195V to 265V)
3. Transformer to have 4 secondary windings as show in the adjacent drawing
4. Loaded DC voltages specified at 195V AC in (with transformer primaries in series)
5. Each secondary winding to have a full wave (diode) bridge to produce a single DC rail (AS shown in diagram)

Output Capacitance is as indicated in table.

The specified voltage figure with the input voltage is to be the minimum voltage on the reservoir capacitor as shown in the diagram.

6. The transformer is intended to be massively overrated so as to provide very low resistance windings for the VP24V7 and VN24V7 supplies.

This will improve the audio quality of the equipment it is to be used in by allowing the flux density to be very low and the wire gauge to be larger than would otherwise be the case. The sizes given are maximum finished sizes.

There is no merit in attempting to reduce the size much below the maximum sizes specified. Audio quality will be improved by making the transformer as large as possible.

7. The VP18 and VP18 secondaries are fused by T250mA Fuses.
The VP24V7 and VN24V7 secondary windings are unfused.

The transformer must be designed so that a short on either of the unfused windings will cause the primary fuses (2AT) to blow.

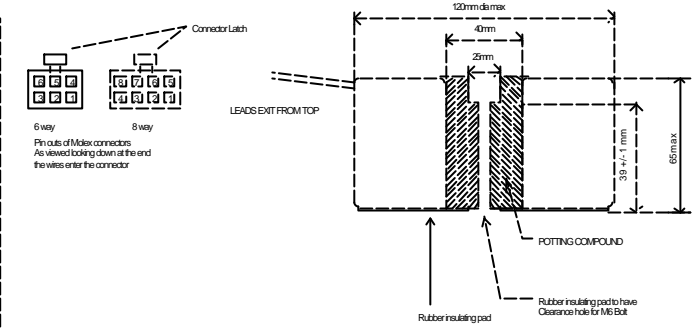

Supply	DC Voltage Min 'see diagram At 195V rms in	Load Current	Output Capacitance
VP24V7	21.0V	20mA	1000µF
VN24V7	21.0V	20mA	1000µF
VP18	38.0V	50mA	100µF
VP18	15.0V	180mA	100µF

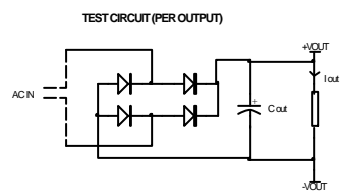
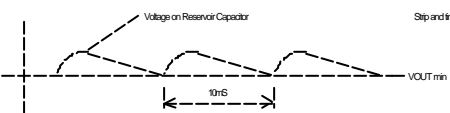
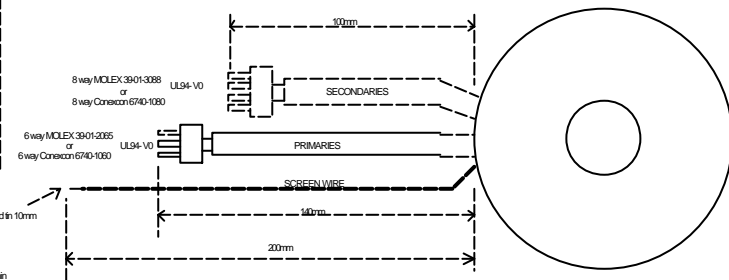
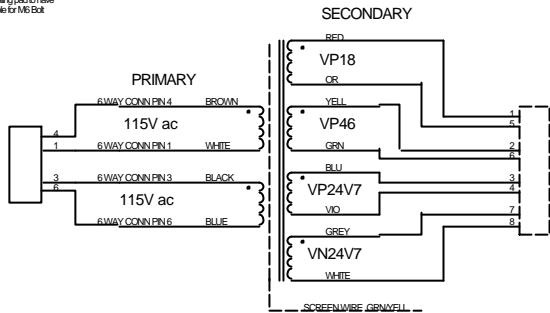

DRAWING TITLE		C30 TRANSFORMER 115/230V				
23425	Filename: L923TX_20sch	03_E110	GU	10/03/03	Potting resin to top of transformer Pins to be cut to 38mm from bottom face of transformer	20
	Notes:	03_E09	GU	4/03/03	Screen wire length from 140mm to 200mm Anchored Connector alternative connectors	10
			KAL	4-11-2002	Prototype Release	A.0
		ECO No.	INITIALS	DATE	DESCRIPTION OF CHANGE	ISSUE
	Contact Engineer: Kevin Lamb	Contact Tel: (01223) 203200	Printed: 11-Apr-2003	Sheet 1 of 1	DRAWING NO. L923TX	

Transformer Specification For 100V C30 transformer

Arcam Part Number L922TX

Material Safety Specification

1. Winding Wire to be Grade 2 (130C rating) to BS 60317-4 1995
2. Mylar Polyester Insulator 130C Rated
3. Potting Compound PC3502 E135297(M)

Mechanical Specification

1. Middle of transformer to be potted (as shown).
2. Primary windings connect to 6 way MOLEX connector 39-01-2065. Secondary windings connect to 8 way molex connector 39-01-3088. Use MOLEX pin 44476-3112. MOLEX connectors have pin numbers indicated on them.
3. Primary wires are enclosed in a common sleeve. Secondary wires are enclosed in a common sleeve. Use PVC sleeving.
4. All wire lengths in mm. Lengths are +5.0, -0
5. Please adhere rubber insulating pad to bottom of transformer as shown.

Electrical Specification

1. Transformer to have dual 100V primaries to allow parallel operation for 100V input.
2. Transformer input voltage range
100V -15% +15% (85V to 115Vrms)
3. Transformer to have 4 secondary windings as show in the adjacent drawing.
4. Loaded DC voltages specified at 85V AC in (with transformer primaries in parallel)
5. Each secondary winding to have a full wave (4diode) bridge to produce a single DC rail. (AS shown in diagram)

Output Capacitance is as indicated in table.

The specified voltage figure with this input voltage is to be the minimum voltage on the reservoir capacitor as shown in the diagram.

6. The transformer is intended to be massively overrated so as to provide very low resistance windings for the VP24V7 and VN24V7 supplies.

This will improve the audio quality of the equipment it is to be used in by allowing the flux density to be very low and the wire gauge to be larger than would otherwise be the case. The sizes given are maximum finished sizes.

There is no merit in attempting to reduce the size much below the maximum sizes specified. Audio quality will be improved by making the transformer as large as possible.

7. The VP46 and VP18 secondaries are fused by T250mA Fuses. The VP24V7 and VN24V7 secondary windings are unfused.

The transformer must be designed so that a short on either of the unfused windings will cause the primary fuses (2AT) to blow.

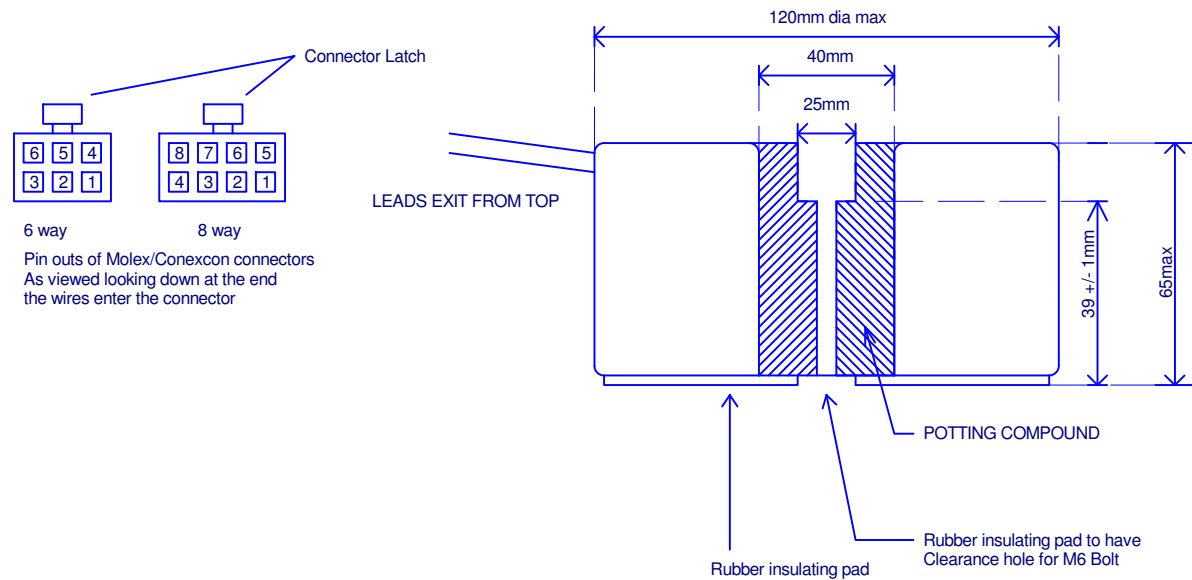

Supply	DC Voltage Min *see diagram At 85V rms in	Load Current	Output Capacitance
VP24V7	21.0V	200mA	10,000uF
VN24V7	21.0V	200mA	10,000uF
VP46	39.0V	50mA	100uF
VP18	15.0V	160mA	1000uF

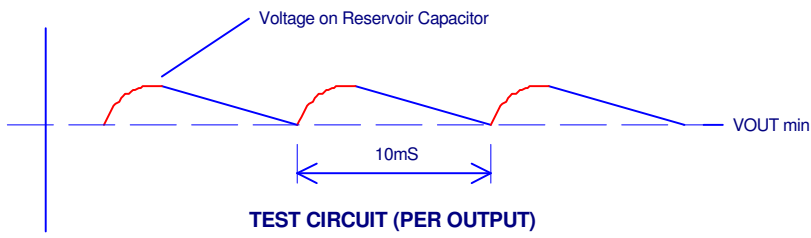
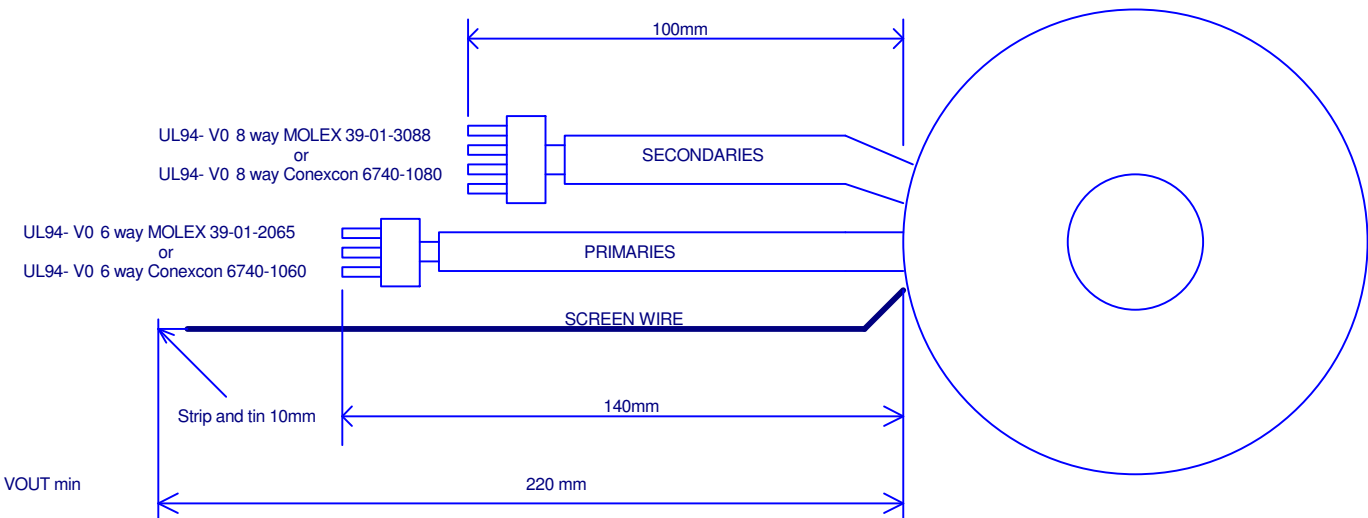
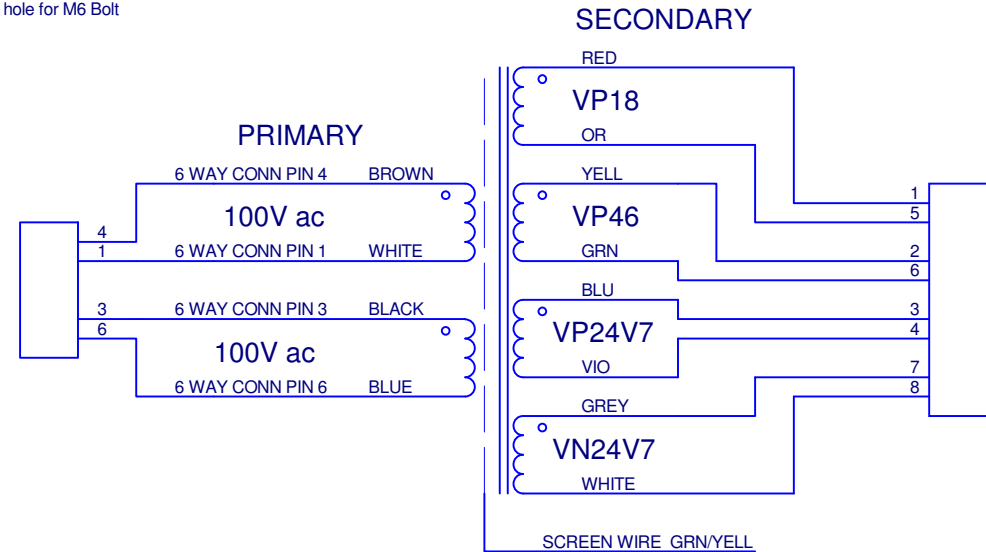

TEST CIRCUIT (PER OUTPUT)

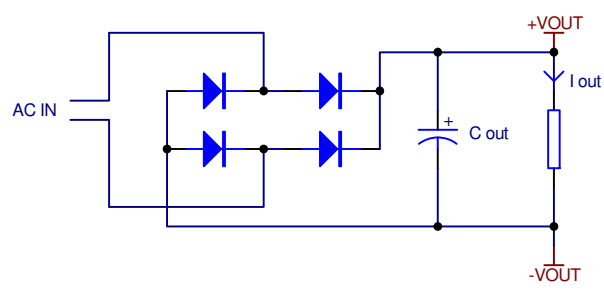

DRAWING TITLE		C30 TRANSFORMER 100V			
ARCAM A & R Cambridge Ltd. Pembroke Avenue Waterbeach Cambridge CB5 9PB	Filename: L922TX_1.0.sch	SLS	13-10-2003	Production Release	1.0
	Notes:	GJ	15/05/03	ECO 03_E137 -Screen lead lengthen to 220 mm Conexcon connector added, potting filled to top of TX	B.0
		KAL	4-11-2002	Prototype Release	A.0
		ECO No.	INITIALS	DATE	DESCRIPTION OF CHANGE
Contact Engineer: Kevin Lamb	Contact Tel: (01223) 203200	Printed: 13-Oct-2003	Sheet 1 of 1	DRAWING NO. L922TX	

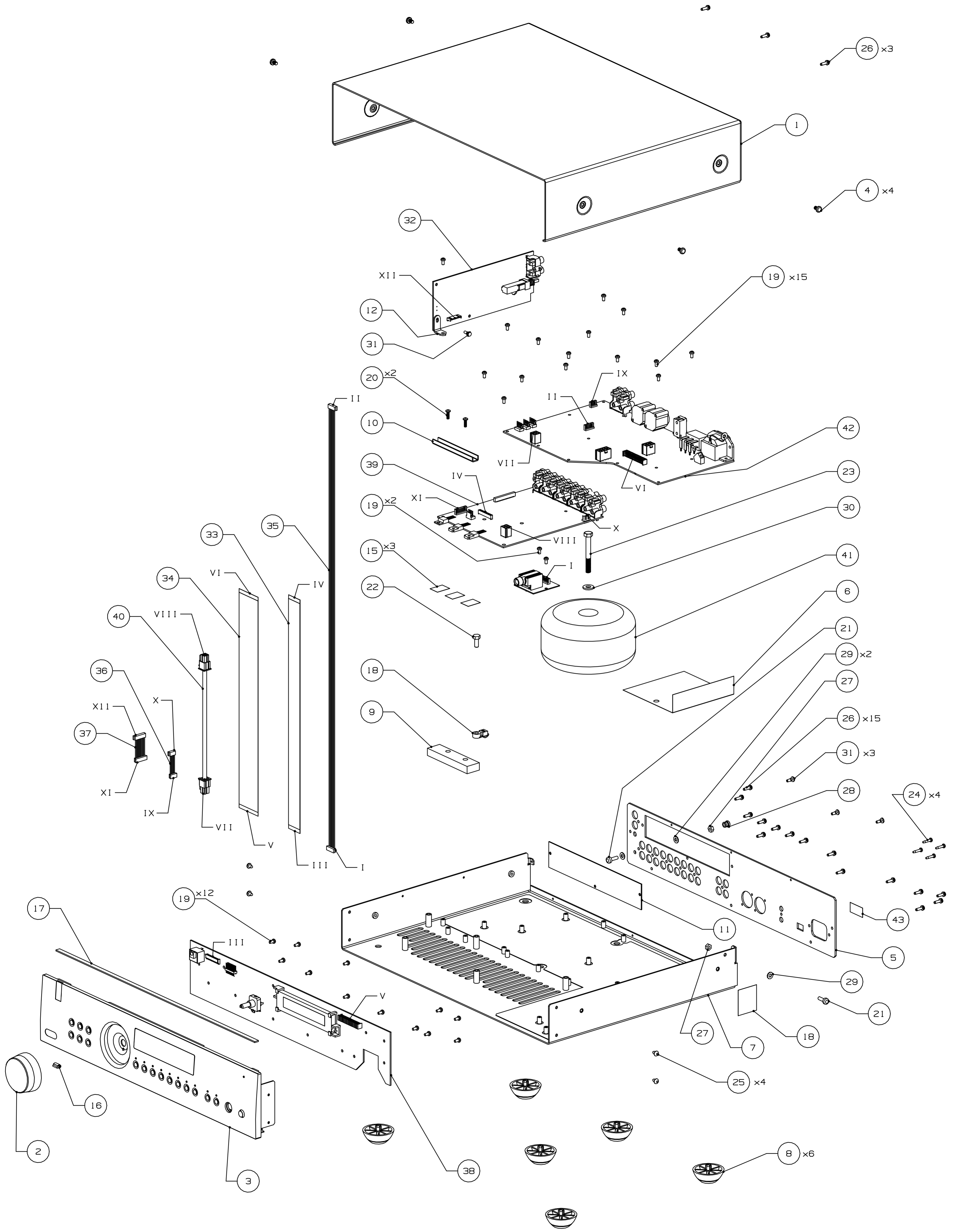

C30 Mechanical and packing parts list

Part no	Item no	Description
		GENERAL MECHANICAL PARTS
E186AY	5	Rear Panel Assembly FMJ C30
E804MI	6	Insulator Mains Diva A85 / P85
E212AY	7	FMJ A32 Chassis Assembly
E822PM1	8	Foot Black Alpha
E850MC	9	Heat Shunt Diva A85
E853MC	10	Clamp Pre-Amp Reg Diva A85
E860MC	11	Blanking Plate Diva A85 Module Slot
E878MC	12	Bracket Diva Phono Upgrade Board
E879SL	13	Label Mod State
F082	15	Sil Pad For TO-220 HS Insulator
F094	16	Clip Volume Knob FMJ
F164	17	Tape 3509 BK 3M TESA.50M Per Roll x 6MM Wide
F235	18	Cable Tie 4.8mm Wide 171.5mm Long 5.3mm Fixing Hole Dia
HA3V06A	19	M Screw Torx P/H M3x6MM ST ZP
HA3V10A	20	M Screw Torx M3x10MM ST ZP
HA4A12B	21	M Screw Pan Supa M4x12MM ST BLK
HA5L12B	22	Screw Hex Head M5X12MM Black
HA6K50A	23	Bolt Hex HD M6x50MM Mczp
HB25V12B	24	Screw Taptite M2.5X12MM Pan Torx(T8) Steel Zinc Plate Black
HE6V06B	25	Screw Sftp Torx No.6x6MM BLK
HF4V09B	26	Screw Self-Tapping-Sems NO.4 X 9MM Pan Torx-Slot Steel Zinc-Plate BLK
HJ4A00A	27	Nut M4 Full ST ZP
HJ4C00D	28	Nut M4 Waisted BR SC
HL4SB	29	Washer M4 Int Shakeproof BLK
HL6MA	30	Bright Washer M6 (Mudguard O.D. 20mm)
HP008	31	Snap Rivet Black Plastic
L870AY	32	A85 Phono Stage PCB
L914CA	33	Cable FFC 22 Way A85 Disp - Pre
L915CA	34	Cable FFC 0.1" 14WAY A85 Disp - Pwr
L928CA	35	6 Way Amp CT 600MM
L917CA	36	Cable A85 Pre - Pwr
L918CA	37	Cable A85 Phono - Preamp
L928AY	38	A32 FMJ Amp Display Board Assembly
L965AY	39	C30 Preamp PCB Assembly
L965CA	40	4-way MOLEX cable 22AWG 190mm long
L923TX	41	Transformer Toroid C30 115/230V
L922TX	41	Transformer Toroid C30 100V
L958AY_115/230V	42	C30 Preamp PSU PCB 115/230V
L955AY		C30 7.1 multichannel expansion module
		BLACK CASE PARTS
E847CPB	1	Cover Black FMJ C30
E839AYB	2	FMJ Black Volume Knob
HA4V06B	4	M Screw Torx M4x6MM ST BLK
E185AYB	3	FMJ Black C30 Fascia Complete Assembly
		Made up of the following parts :-
E188AYB		Front Panel Assembly Black FMJ C30
E083AY		FMJ A32 Sub-Panel Assy
8Q006		8Q006 FMJ Tact Button Spring
HL25AB		HL25AB FMJ Tact Button Fastener
E849PMB		Button FMJ Black Tac
E830MC		Badge Metal Arcam FMJ
E933AY		FMJ I/R Window Assy (STD. SCREENED)
E884MC		Display Window FMJ A32
HA3A04A		M/C Pan Supa M3X4 Stzp
E847PM		Lightpipe FMJ
E895PMB		Button Tact FMJ A32 Black Low Profile
E894PMB		Button Power FMJ A32 Black

C30 Mechanical and packing parts list

Part no	Item no	Description
		SILVER CASE PARTS
E847CP	1	Cover Silver FMJ C30
E839AY	2	FMJ Silver Volume Knob
HA4V06S	4	M Screw Torx M4x6MM Stainless Steel
E185AY	3	FMJ Silver C30 Fascia Complete Assembly
		Made up of the following parts :-
E188AY		Front Panel Assembly Silver FMJ C30
E083AY		FMJ A32 Sub-Panel Assy
8Q006		8Q006 FMJ Tact Button Spring
HL25AB		HL25AB FMJ Tact Button Fastener
E849PM		Button FMJ Tac
E830MC		Badge Metal Arcam FMJ
E933AY		FMJ I/R Window Assy (STD. SCREENED)
E884MC		Display Window FMJ A32
HA3A04A		M/C Pan Supa M3X4 Stzp
E847PM		Lightpipe FMJ
E895PM		Button Silver FMJ A32 Low Profile Tact
E894PM		Button Power FMJ A32 Silver

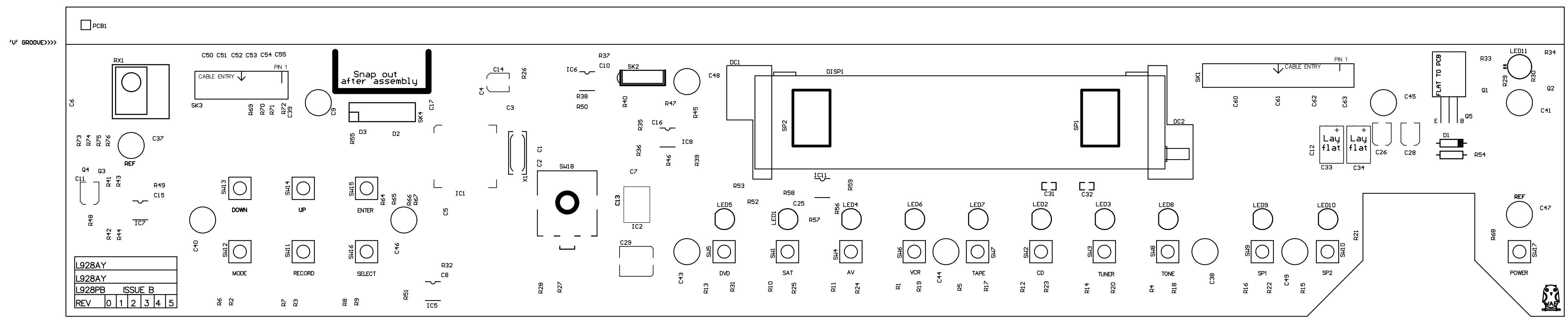

L928AY	
L928AY	
L928PB	ISSUE B
REV	0 1 2 3 4 5

MECHANICAL DATA	
LAYER STACKUP	
D:\FILESYS\REF>J:\Development\Ref_Designs\VMJ_cmp_A32\Display & Microconroler PCB\L928 A32 DISPLAY BOARD\L928AY_A.ddb\$OP>\$ON>L928PB_B.pcb\$D>25\$ATTR>0\$E>PCB\$STF>	

MATERIAL	FR4	NOTES:-
COPPER WEIGHT	1oz	1/ Manufacture in accordance with IPC-A-600F Class 1.
HOLE SIZES	FINISHED (SEE NOTE 2)	2/ Always use NC drill file as reference.
ROUTING	SEE NOTE 3	3/ All routing 2.0mm unless otherwise shown on drill drawing.
COPPER LAYERS	TWO	4/ Mark month/year of manufacture on ident layer.
MINIMUM WIDTH	8 ML	5/ Scoring denoted by ->>> on drill drawing.
MINIMUM GAP	6 ML	
RESIST	GREEN	
IDENT	WHITE	GENERAL TOLERANCES
VENDOR CODES	SEE NOTE 4	PCB Dims. +/- 0.2mm
FINISH	SILVER	Routing +/- 0.1mm
SCORING	SEE NOTE 5	All holes +/- 0.08mm
		ALL DIMENSIONS IN MILLIMETERS UNLESS OTHERWISE STATED

DRAWING TITLE		A32 DISPLAY BOARD	---	---	---	---	---
		Top Overlay	---	---	---	---	---
		Filename: L928PB_B.pcb	---	---	---	---	---
		DRAWING NO.	---	WAF	10/8/01	UPDATED PROTOTYPE	B
		L928PB	---	WAF	16/7/01	INITIAL PROTOTYPE	A
		E.C.O. No.	INITIALS	DATE	DESCRIPTION OF CHANGE		ISSUE
		Contact Engineer: Cliff Lawrence	Contact Tel: +44 (0) 1223 203294		Printed: 13-Aug-2001		Sheet 2 of 10

C30 Preamplifier display cct board L928AY issue B3.0

Designator	Part	Description
C1	2C018	MLC 18P 50V X7R 10% SM
C2	2C018	MLC 18P 50V X7R 10% SM
C3	2C410	MLC 100N 50V X7R 10% SM
C4	2C410	MLC 100N 50V X7R 10% SM
C5	2C410	MLC 100N 50V X7R 10% SM
C6	2C410	MLC 100N 50V X7R 10% SM
C7	2C410	MLC 100N 50V X7R 10% SM
C8	2C410	MLC 100N 50V X7R 10% SM
C9	2C410	MLC 100N 50V X7R 10% SM
C10	2C410	MLC 100N 50V X7R 10% SM
C11	2M610	ELST 10U 50V SM
C12	2C410	MLC 100N 50V X7R 10% SM
C13	2C410	MLC 100N 50V X7R 10% SM
C14	2M610	ELST 10U 50V SM
C15	2C410	MLC 100N 50V X7R 10% SM
C16	2C410	MLC 100N 50V X7R 10% SM
C17	2C410	MLC 100N 50V X7R 10% SM
C25	2C410	MLC 100N 50V X7R 10% SM
C26	2M610	ELST 10U 50V SM
C28	2M610	ELST 10U 50V SM
C29	2M710	ELST 100U 25V SM
C31	2C010A	MLC 10P 50V NPO 10% SM
C32	2C010A	MLC 10P 50V NPO 10% SM
C33	2N722	ELST 220U 16V
C34	2N722	ELST 220U 16V
C37	2C210	MLC 1N0 50V X7R 10% SM
C38	2C210	MLC 1N0 50V X7R 10% SM
C39	2C210	MLC 1N0 50V X7R 10% SM
C40	2C210	MLC 1N0 50V X7R 10% SM
C41	2C210	MLC 1N0 50V X7R 10% SM
C43	2C210	MLC 1N0 50V X7R 10% SM
C44	2C210	MLC 1N0 50V X7R 10% SM
C45	2C210	MLC 1N0 50V X7R 10% SM
C46	2C210	MLC 1N0 50V X7R 10% SM
C47	2C210	MLC 1N0 50V X7R 10% SM
C48	2C210	MLC 1N0 50V X7R 10% SM
C49	2C210	MLC 1N0 50V X7R 10% SM
C50	2W110X4	CAP PACK NPO 0612 4X100P 50V 5%
C51	2W110X4	CAP PACK NPO 0612 4X100P 50V 5%
C52	2W110X4	CAP PACK NPO 0612 4X100P 50V 5%
C53	2W110X4	CAP PACK NPO 0612 4X100P 50V 5%
C54	2W110X4	CAP PACK NPO 0612 4X100P 50V 5%
C55	2W110X4	CAP PACK NPO 0612 4X100P 50V 5%
C60	2W110X4	CAP PACK NPO 0612 4X100P 50V 5%
C61	2W110X4	CAP PACK NPO 0612 4X100P 50V 5%
C62	2W110X4	CAP PACK NPO 0612 4X100P 50V 5%
C63	2W110X4	CAP PACK NPO 0612 4X100P 50V 5%
D1	3C13304	ZENER 33V BZX55C33V
D2	3AS16W	DIODE SS SM BAS16W
D3	3AS16W	DIODE SS SM BAS16W
DC1	E916PM	DISPLAY CRADLE E916PM
DC2	E916PM	DISPLAY CRADLE E916PM
DISP1	B1013	MN12818A VFD ITRON
IC1	5H3048	H8/3048 128K FLASH MICROCONTROLLER
IC2	5H1233A	IC MICRO RESET DS1233 SM
IC5	5G2402	IC CMOS EPROM 24C02 SM
IC6	5M393AD	IC COMPARATOR SM DUAL LM393A
IC7	5M393AD	IC COMPARATOR SM DUAL LM393A
IC8	5M393AD	IC COMPARATOR SM DUAL LM393A
IC11	5M8532	DUAL OUTPUT SINGLE SUPPLY AMP AD8532
LED1	3D001	LED GREEN 5MM
LED2	3D001	LED GREEN 5MM

C30 Preamplifier display cct board L928AY issue B3.0

Designator	Part	Description
LED3	3D001	LED GREEN 5MM
LED4	3D001	LED GREEN 5MM
LED5	3D001	LED GREEN 5MM
LED6	3D001	LED GREEN 5MM
LED7	3D001	LED GREEN 5MM
LED8	3D001	LED GREEN 5MM
LED9	3D001	LED GREEN 5MM
LED10	3D001	LED GREEN 5MM
LED11	3D006	LED RED/GREEN 3MM L-93WEGW
Q1	4A847	TRANS LF SS N SM BC847B
Q2	4A847	TRANS LF SS N SM BC847B
Q3	4A847	TRANS LF SS N SM BC847B
Q4	4A847	TRANS LF SS N SM BC847B
Q5	4B179	NPN TRANS MP BD179
R1	1A310	RES SM W4 2% 10K
R2	1A310	RES SM W4 2% 10K
R3	1A310	RES SM W4 2% 10K
R4	1A310	RES SM W4 2% 10K
R5	1A310	RES SM W4 2% 10K
R6	1A310	RES SM W4 2% 10K
R7	1A310	RES SM W4 2% 10K
R8	1A310	RES SM W4 2% 10K
R9	1A310	RES SM W4 2% 10K
R10	1A310	RES SM W4 2% 10K
R11	1A310	RES SM W4 2% 10K
R12	1A310	RES SM W4 2% 10K
R13	1A310	RES SM W4 2% 10K
R14	1A310	RES SM W4 2% 10K
R15	1A310	RES SM W4 2% 10K
R16	1A310	RES SM W4 2% 10K
R17	1A133	RES SM W4 2% 330R
R18	1A133	RES SM W4 2% 330R
R19	1A133	RES SM W4 2% 330R
R20	1A133	RES SM W4 2% 330R
R21	1A133	RES SM W4 2% 330R
R22	1A133	RES SM W4 2% 330R
R23	1A133	RES SM W4 2% 330R
R24	1A133	RES SM W4 2% 330R
R25	1A133	RES SM W4 2% 330R
R26	1A310	RES SM W4 2% 10K
R27	1A310	RES SM W4 2% 10K
R28	1A310	RES SM W4 2% 10K
R29	1A310	RES SM W4 2% 10K
R30	1A310	RES SM W4 2% 10K
R31	1A133	RES SM W4 2% 330R
R32	1A310	RES SM W4 2% 10K
R33	1A133	RES SM W4 2% 330R
R34	1A115	RES SM W4 2% 150R
R35	1A310	RES SM W4 2% 10K
R36	1A310	RES SM W4 2% 10K
R37	1A310	RES SM W4 2% 10K
R38	1A212	RES SM W4 2% 1K2
R39	1A222	RES SM W4 2% 2K2
R40	1A247	RES SM W4 2% 4K7
R41	1A410	RES SM W4 2% 100K
R42	1A410	RES SM W4 2% 100K
R43	1A410	RES SM W4 2% 100K
R44	1A410	RES SM W4 2% 100K
R45	1A310	RES SM W4 2% 10K
R46	1A212	RES SM W4 2% 1K2
R47	1A247	RES SM W4 2% 4K7
R48	1A000	RES SM W4 2% 0R0

C30 Preamplifier display cct board L928AY issue B3.0

Designator	Part	Description
R49	1A310	RES SM W4 2% 10K
R50	1A310	RES SM W4 2% 10K
R51	1A110	RES SM W4 1% 100R 1206
R52	1A110	RES SM W4 1% 100R 1206
R53	1A110	RES SM W4 1% 100R 1206
R54	1H233	RES MF W4 1% 3K3
R55	1A310	RES SM W4 2% 10K
R56	1A310	RES SM W4 2% 10K
R57	1A310	RES SM W4 2% 10K
R58	1A000	RES SM W4 2% 0R0
R59	1A000	RES SM W4 2% 0R0
R64	1A110	RES SM W4 1% 100R 1206
R65	1A110	RES SM W4 1% 100R 1206
R66	1A110	RES SM W4 1% 100R 1206
R67	1A110	RES SM W4 1% 100R 1206
R68	1A310	RES SM W4 2% 10K
R69	1A822	RES SM W4 1% 2R2 1206
R70	1A822	RES SM W4 1% 2R2 1206
R71	1A822	RES SM W4 1% 2R2 1206
R72	1A822	RES SM W4 1% 2R2 1206
R73	1A310	RES SM W4 2% 10K
R74	1A310	RES SM W4 2% 10K
R75	1A310	RES SM W4 2% 10K
R76	1A310	RES SM W4 2% 10K
RX1	B2107	REMOTE RX PIC-26043TM2 38KHZ
SK1	8K7014A	FFC 14W 2.54MM HOR PTH
SK2	8K2005	5-WAY AMP CT CONN
SK3	8K8022A	22-WAY FFC CONN HORIZ 1MM PTH
SK4	8K6315	14 WAY DIL HEADER HORIZ
SP1	F195	LED SPACER
SP2	F195	LED SPACER
SP3	F195	LED SPACER
SP4	F195	LED SPACER
SP5	F195	LED SPACER
SP6	F195	LED SPACER
SP7	F195	LED SPACER
SP8	F195	LED SPACER
SP9	F195	LED SPACER
SP10	F195	LED SPACER
SP101	F163	STICKY PAD S/A 10 X 15mm
SP102	F163	STICKY PAD S/A 10 X 15mm
SP103	E822AP	IR RX SUPPORT PAD
SW1	A1505	TACT SWITCH SM SDTM-610-NTR
SW2	A1505	TACT SWITCH SM SDTM-610-NTR
SW3	A1505	TACT SWITCH SM SDTM-610-NTR
SW4	A1505	TACT SWITCH SM SDTM-610-NTR
SW5	A1505	TACT SWITCH SM SDTM-610-NTR
SW6	A1505	TACT SWITCH SM SDTM-610-NTR
SW7	A1505	TACT SWITCH SM SDTM-610-NTR
SW8	A1505	TACT SWITCH SM SDTM-610-NTR
SW9	A1505	TACT SWITCH SM SDTM-610-NTR
SW10	A1505	TACT SWITCH SM SDTM-610-NTR
SW11	A1505	TACT SWITCH SM SDTM-610-NTR
SW12	A1505	TACT SWITCH SM SDTM-610-NTR
SW13	A1505	TACT SWITCH SM SDTM-610-NTR
SW14	A1505	TACT SWITCH SM SDTM-610-NTR
SW15	A1505	TACT SWITCH SM SDTM-610-NTR
SW16	A1505	TACT SWITCH SM SDTM-610-NTR
SW17	A1505	TACT SWITCH SM SDTM-610-NTR
SW18	A1211	EC16B2414
X1	7X040	XTAL 16MHZ SM GSX49-4

C30 Preamplifier 7.1 multichannel cct board L955AY issue 1.0

Designator	Part	Description
C100	2N747	Capacitor Radial Electrolytic Dia 10mm Pitch 5mm 470UF 25V
C101	2N747	Capacitor Radial Electrolytic Dia 10mm Pitch 5mm 470UF 25V
C102	2KA433	Capacitor Boxed Polyester 5mm Pitch 5% 100VDC 330N
C103	2N510	Capacitor Radial Electrolytic Dia 5mm Pitch 5mm 1UF 50V
C104	2N510	Capacitor Radial Electrolytic Dia 5mm Pitch 5mm 1UF 50V
C105	2KA410	Capacitor Boxed Polyester 5mm Pitch 5% 100VDC 100N
C106	2N722	Capacitor Radial Electrolytic Dia 6.3mm Pitch 5mm 220UF 16V
C107	2N710	Capacitor Radial Electrolytic Dia 5mm Pitch 5mm 100UF 25V
C109	2J410	Capacitor SM 0805 X7R Ceramic 10% 50V 100N
C110	2J410	Capacitor SM 0805 X7R Ceramic 10% 50V 100N
C111	2J410	Capacitor SM 0805 X7R Ceramic 10% 50V 100N
C112	2J410	Capacitor SM 0805 X7R Ceramic 10% 50V 100N
C113	2J410	Capacitor SM 0805 X7R Ceramic 10% 50V 100N
C114	2J410	Capacitor SM 0805 X7R Ceramic 10% 50V 100N
C115	2J410	Capacitor SM 0805 X7R Ceramic 10% 50V 100N
C116	2J410	Capacitor SM 0805 X7R Ceramic 10% 50V 100N
C117	2J410	Capacitor SM 0805 X7R Ceramic 10% 50V 100N
C118	2L110	Capacitor SM 0805 NPO Ceramic 5% 100V 100P
C119	2M710	Capacitor Surface Mount Electrolytic Dia 8mm 100UF 25V
C120	2M610	Capacitor Surface Mount Electrolytic Dia 5mm 10UF 50V
C121	2L110	Capacitor SM 0805 NPO Ceramic 5% 100V 100P
C122	2J410	Capacitor SM 0805 X7R Ceramic 10% 50V 100N
C123	2L110	Capacitor SM 0805 NPO Ceramic 5% 100V 100P
C124	2L110	Capacitor SM 0805 NPO Ceramic 5% 100V 100P
C125	2L110	Capacitor SM 0805 NPO Ceramic 5% 100V 100P
C126	2L110	Capacitor SM 0805 NPO Ceramic 5% 100V 100P
C127	2L110	Capacitor SM 0805 NPO Ceramic 5% 100V 100P
C128	2J410	Capacitor SM 0805 X7R Ceramic 10% 50V 100N
C129	2L110	Capacitor SM 0805 NPO Ceramic 5% 100V 100P
C130	2J410	Capacitor SM 0805 X7R Ceramic 10% 50V 100N
C132	2L110	Capacitor SM 0805 NPO Ceramic 5% 100V 100P
C200	2JA310	Capacitor SM 0805 X7R Ceramic 10% 100V 10N
C201	2JA310	Capacitor SM 0805 X7R Ceramic 10% 100V 10N
C202	2JA310	Capacitor SM 0805 X7R Ceramic 10% 100V 10N
C203	2JA310	Capacitor SM 0805 X7R Ceramic 10% 100V 10N
C204	2L110	Capacitor SM 0805 NPO Ceramic 5% 100V 100P
C205	2L110	Capacitor SM 0805 NPO Ceramic 5% 100V 100P
C206	2L110	Capacitor SM 0805 NPO Ceramic 5% 100V 100P
C207	2L110	Capacitor SM 0805 NPO Ceramic 5% 100V 100P
C208	2L110	Capacitor SM 0805 NPO Ceramic 5% 100V 100P
C209	2L110	Capacitor SM 0805 NPO Ceramic 5% 100V 100P
C210	2L110	Capacitor SM 0805 NPO Ceramic 5% 100V 100P
C211	2L110	Capacitor SM 0805 NPO Ceramic 5% 100V 100P
C212	2L110	Capacitor SM 0805 NPO Ceramic 5% 100V 100P
C213	2L110	Capacitor SM 0805 NPO Ceramic 5% 100V 100P
C214	2L110	Capacitor SM 0805 NPO Ceramic 5% 100V 100P
C215	2L110	Capacitor SM 0805 NPO Ceramic 5% 100V 100P
C216	2L110	Capacitor SM 0805 NPO Ceramic 5% 100V 100P
C217	2L110	Capacitor SM 0805 NPO Ceramic 5% 100V 100P
C218	2L110	Capacitor SM 0805 NPO Ceramic 5% 100V 100P
C219	2L110	Capacitor SM 0805 NPO Ceramic 5% 100V 100P
C220	2J410	Capacitor SM 0805 X7R Ceramic 10% 50V 100N
C221	2J410	Capacitor SM 0805 X7R Ceramic 10% 50V 100N
C222	2J410	Capacitor SM 0805 X7R Ceramic 10% 50V 100N
C223	2J410	Capacitor SM 0805 X7R Ceramic 10% 50V 100N
C224	2J410	Capacitor SM 0805 X7R Ceramic 10% 50V 100N
C225	2J410	Capacitor SM 0805 X7R Ceramic 10% 50V 100N
C226	2J410	Capacitor SM 0805 X7R Ceramic 10% 50V 100N
C227	2J410	Capacitor SM 0805 X7R Ceramic 10% 50V 100N
C228	2J410	Capacitor SM 0805 X7R Ceramic 10% 50V 100N
C229	2J410	Capacitor SM 0805 X7R Ceramic 10% 50V 100N

C30 Preamplifier 7.1 multichannel cct board L955AY issue 1.0

Designator	Part	Description
C230	2J410	Capacitor SM 0805 X7R Ceramic 10% 50V 100N
C231	2J410	Capacitor SM 0805 X7R Ceramic 10% 50V 100N
C304	2M610	Capacitor Surface Mount Electrolytic Dia 5mm 10UF 50V
C305	2M610	Capacitor Surface Mount Electrolytic Dia 5mm 10UF 50V
C306	2M610	Capacitor Surface Mount Electrolytic Dia 5mm 10UF 50V
C307	2M610	Capacitor Surface Mount Electrolytic Dia 5mm 10UF 50V
C312	2M610	Capacitor Surface Mount Electrolytic Dia 5mm 10UF 50V
C313	2M610	Capacitor Surface Mount Electrolytic Dia 5mm 10UF 50V
C318	2M610	Capacitor Surface Mount Electrolytic Dia 5mm 10UF 50V
C319	2M610	Capacitor Surface Mount Electrolytic Dia 5mm 10UF 50V
C323	2M610	Capacitor Surface Mount Electrolytic Dia 5mm 10UF 50V
C324	2M610	Capacitor Surface Mount Electrolytic Dia 5mm 10UF 50V
C326	2M610	Capacitor Surface Mount Electrolytic Dia 5mm 10UF 50V
C328	2M610	Capacitor Surface Mount Electrolytic Dia 5mm 10UF 50V
C329	2J410	Capacitor SM 0805 X7R Ceramic 10% 50V 100N
C330	2J410	Capacitor SM 0805 X7R Ceramic 10% 50V 100N
C331	2J410	Capacitor SM 0805 X7R Ceramic 10% 50V 100N
C332	2J410	Capacitor SM 0805 X7R Ceramic 10% 50V 100N
C333	2J410	Capacitor SM 0805 X7R Ceramic 10% 50V 100N
C334	2J410	Capacitor SM 0805 X7R Ceramic 10% 50V 100N
C335	2J410	Capacitor SM 0805 X7R Ceramic 10% 50V 100N
C336	2J410	Capacitor SM 0805 X7R Ceramic 10% 50V 100N
C337	2J410	Capacitor SM 0805 X7R Ceramic 10% 50V 100N
C338	2J410	Capacitor SM 0805 X7R Ceramic 10% 50V 100N
C339	2J410	Capacitor SM 0805 X7R Ceramic 10% 50V 100N
C340	2J410	Capacitor SM 0805 X7R Ceramic 10% 50V 100N
C341	2J410	Capacitor SM 0805 X7R Ceramic 10% 50V 100N
C342	2J410	Capacitor SM 0805 X7R Ceramic 10% 50V 100N
C343	2J410	Capacitor SM 0805 X7R Ceramic 10% 50V 100N
C344	2J410	Capacitor SM 0805 X7R Ceramic 10% 50V 100N
C345	2J410	Capacitor SM 0805 X7R Ceramic 10% 50V 100N
C346	2J410	Capacitor SM 0805 X7R Ceramic 10% 50V 100N
C347	2J410	Capacitor SM 0805 X7R Ceramic 10% 50V 100N
C348	2J410	Capacitor SM 0805 X7R Ceramic 10% 50V 100N
C349	2J410	Capacitor SM 0805 X7R Ceramic 10% 50V 100N
C350	2J410	Capacitor SM 0805 X7R Ceramic 10% 50V 100N
C351	2J410	Capacitor SM 0805 X7R Ceramic 10% 50V 100N
C352	2J410	Capacitor SM 0805 X7R Ceramic 10% 50V 100N
C353	2J410	Capacitor SM 0805 X7R Ceramic 10% 50V 100N
C354	2J410	Capacitor SM 0805 X7R Ceramic 10% 50V 100N
C355	2J410	Capacitor SM 0805 X7R Ceramic 10% 50V 100N
C356	2J410	Capacitor SM 0805 X7R Ceramic 10% 50V 100N
C357	2J410	Capacitor SM 0805 X7R Ceramic 10% 50V 100N
C358	2J410	Capacitor SM 0805 X7R Ceramic 10% 50V 100N
C359	2J410	Capacitor SM 0805 X7R Ceramic 10% 50V 100N
C360	2J410	Capacitor SM 0805 X7R Ceramic 10% 50V 100N
C361	2J410	Capacitor SM 0805 X7R Ceramic 10% 50V 100N
C362	2J410	Capacitor SM 0805 X7R Ceramic 10% 50V 100N
C363	2J410	Capacitor SM 0805 X7R Ceramic 10% 50V 100N
C364	2J410	Capacitor SM 0805 X7R Ceramic 10% 50V 100N
C365	2L022	Capacitor SM 0805 NPO Ceramic 5% 100V 22P
C366	2L022	Capacitor SM 0805 NPO Ceramic 5% 100V 22P
C367	2L022	Capacitor SM 0805 NPO Ceramic 5% 100V 22P
C368	2L022	Capacitor SM 0805 NPO Ceramic 5% 100V 22P
C369	2L022	Capacitor SM 0805 NPO Ceramic 5% 100V 22P
C370	2L022	Capacitor SM 0805 NPO Ceramic 5% 100V 22P
C371	2L022	Capacitor SM 0805 NPO Ceramic 5% 100V 22P
C372	2L022	Capacitor SM 0805 NPO Ceramic 5% 100V 22P
C373	2K510	Capacitor Boxed Polyester 5mm Pitch 10% 63V 1U0
C374	2K510	Capacitor Boxed Polyester 5mm Pitch 10% 63V 1U0
C375	2KA447	Capacitor Boxed Polyester 5mm Pitch 5% 100VDC 470N

C30 Preamplifier 7.1 multichannel cct board L955AY issue 1.0

Designator	Part	Description
C376	2KA447	Capacitor Boxed Polyester 5mm Pitch 5% 100VDC 470N
C377	2KA447	Capacitor Boxed Polyester 5mm Pitch 5% 100VDC 470N
C378	2KA447	Capacitor Boxed Polyester 5mm Pitch 5% 100VDC 470N
C379	2KA447	Capacitor Boxed Polyester 5mm Pitch 5% 100VDC 470N
C380	2KA447	Capacitor Boxed Polyester 5mm Pitch 5% 100VDC 470N
C400	2M610	Capacitor Surface Mount Electrolytic Dia 5mm 10UF 50V
C401	2M610	Capacitor Surface Mount Electrolytic Dia 5mm 10UF 50V
C402	2M610	Capacitor Surface Mount Electrolytic Dia 5mm 10UF 50V
C403	2M610	Capacitor Surface Mount Electrolytic Dia 5mm 10UF 50V
C404	2M610	Capacitor Surface Mount Electrolytic Dia 5mm 10UF 50V
C405	2M610	Capacitor Surface Mount Electrolytic Dia 5mm 10UF 50V
C406	2M610	Capacitor Surface Mount Electrolytic Dia 5mm 10UF 50V
C407	2M610	Capacitor Surface Mount Electrolytic Dia 5mm 10UF 50V
C408	2M610	Capacitor Surface Mount Electrolytic Dia 5mm 10UF 50V
C409	2M610	Capacitor Surface Mount Electrolytic Dia 5mm 10UF 50V
C410	2L033	Capacitor SM 0805 NPO Ceramic 5% 100V 33P
C411	2L033	Capacitor SM 0805 NPO Ceramic 5% 100V 33P
C412	2L033	Capacitor SM 0805 NPO Ceramic 5% 100V 33P
C413	2L033	Capacitor SM 0805 NPO Ceramic 5% 100V 33P
C414	2L033	Capacitor SM 0805 NPO Ceramic 5% 100V 33P
C415	2L033	Capacitor SM 0805 NPO Ceramic 5% 100V 33P
C416	2L033	Capacitor SM 0805 NPO Ceramic 5% 100V 33P
C417	2L033	Capacitor SM 0805 NPO Ceramic 5% 100V 33P
C418	2J410	Capacitor SM 0805 X7R Ceramic 10% 50V 100N
C419	2J410	Capacitor SM 0805 X7R Ceramic 10% 50V 100N
C420	2J410	Capacitor SM 0805 X7R Ceramic 10% 50V 100N
C421	2J410	Capacitor SM 0805 X7R Ceramic 10% 50V 100N
C422	2J410	Capacitor SM 0805 X7R Ceramic 10% 50V 100N
C423	2J410	Capacitor SM 0805 X7R Ceramic 10% 50V 100N
C424	2J410	Capacitor SM 0805 X7R Ceramic 10% 50V 100N
C425	2J410	Capacitor SM 0805 X7R Ceramic 10% 50V 100N
C426	2JA310	Capacitor SM 0805 X7R Ceramic 10% 100V 10N
C427	2JA310	Capacitor SM 0805 X7R Ceramic 10% 100V 10N
C428	2L110	Capacitor SM 0805 NPO Ceramic 5% 100V 100P
C429	2L110	Capacitor SM 0805 NPO Ceramic 5% 100V 100P
C108 NF	2J410	Capacitor SM 0805 X7R Ceramic 10% 50V 100N
CON100	8K6604	Con KK Series 0.1in Vertical Friction Lock Hdr 4WAY
CON101	8K6314	Con Hdr Dual ROW 0.1IN Vertical 14WAY
CON400	8K8030B	Con 1.00MM Vertical FFC 30WAY 52806 Series
D100	3F54S	Diode Schottky BAT54S SOT-23 Package
D400	3AV99W	Diode Dual Surface Mount Small Signal BAV99 SOT-23 Package
D401	3AV99W	Diode Dual Surface Mount Small Signal BAV99 SOT-23 Package
D402	3AV99W	Diode Dual Surface Mount Small Signal BAV99 SOT-23 Package
D403	3AV99W	Diode Dual Surface Mount Small Signal BAV99 SOT-23 Package
D404	3AV99W	Diode Dual Surface Mount Small Signal BAV99 SOT-23 Package
D405	3AV99W	Diode Dual Surface Mount Small Signal BAV99 SOT-23 Package
D406	3AS16W	Diode Surface Mount Small Signal BAS16W SOT-23 Package
D407	3AS16W	Diode Surface Mount Small Signal BAS16W SOT-23 Package
HS100	F007	Heatsink TO-220 6043PB 23 Degc/W Clip ON
IC100	L023AY	Programmed PIC16F627T For 7.1 Multichannel Module
IC200	5K4053HCT	IC Triple 2 Channel Analogue Mux 74HCT4053 SO-16
IC201	5K4053HCT	IC Triple 2 Channel Analogue Mux 74HCT4053 SO-16
IC202	5K4053HCT	IC Triple 2 Channel Analogue Mux 74HCT4053 SO-16
IC203	5K4053HCT	IC Triple 2 Channel Analogue Mux 74HCT4053 SO-16
IC204	5K4053HCT	IC Triple 2 Channel Analogue Mux 74HCT4053 SO-16
IC205	5K4053HCT	IC Triple 2 Channel Analogue Mux 74HCT4053 SO-16
IC300	5B2134	Opamp OPA2134UA SO-8 Package
IC301	5B2134	Opamp OPA2134UA SO-8 Package
IC302	5B2134	Opamp OPA2134UA SO-8 Package
IC303	5B2134	Opamp OPA2134UA SO-8 Package
IC304	5B2134	Opamp OPA2134UA SO-8 Package

C30 Preamplifier 7.1 multichannel cct board L955AY issue 1.0

Designator	Part	Description
IC305	5B2134	Opamp OPA2134UA SO-8 Package
IC306	5B2134	Opamp OPA2134UA SO-8 Package
IC307	5B2134	Opamp OPA2134UA SO-8 Package
IC308	5A2310	IC Audio Digital Stereo Volume Ctrl
IC309	5A2310	IC Audio Digital Stereo Volume Ctrl
IC310	5A2310	IC Audio Digital Stereo Volume Ctrl
IC311	5A2310	IC Audio Digital Stereo Volume Ctrl
IC400	5B2134	Opamp OPA2134UA SO-8 Package
IC401	5B2134	Opamp OPA2134UA SO-8 Package
IC402	5B2134	Opamp OPA2134UA SO-8 Package
IC403	5B2134	Opamp OPA2134UA SO-8 Package
ITEM100-1	L955PB	Blank PCB 7.1 Mch PCB
ITEM101-1	E802AP	Pad Damping 15x6x3MM Sorbothane
ITEM102-1	E802AP	Pad Damping 15x6x3MM Sorbothane
ITEM103-1	E802AP	Pad Damping 15x6x3MM Sorbothane
ITEM104-1	E802AP	Pad Damping 15x6x3MM Sorbothane
ITEM105-1	E802AP	Pad Damping 15x6x3MM Sorbothane
L100	7C033B	=Inductor 33UH 10% 1.17A
R100	1M310	Resistor 0805 Surface Mount 0.125W 1% 10K
R101	1M347	Resistor 0805 Surface Mount 0.125W 1% 47K
R102	1M110	Resistor 0805 Surface Mount 0.125W 1% 100R
R103	1M210	Resistor 0805 Surface Mount 0.125W 1% 1K0
R104	1M210	Resistor 0805 Surface Mount 0.125W 1% 1K0
R105	1M210	Resistor 0805 Surface Mount 0.125W 1% 1K0
R106	1M210	Resistor 0805 Surface Mount 0.125W 1% 1K0
R107	1M210	Resistor 0805 Surface Mount 0.125W 1% 1K0
R108	1M110	Resistor 0805 Surface Mount 0.125W 1% 100R
R109	1M110	Resistor 0805 Surface Mount 0.125W 1% 100R
R110	1M310	Resistor 0805 Surface Mount 0.125W 1% 10K
R111	1M210	Resistor 0805 Surface Mount 0.125W 1% 1K0
R112	1M133	Resistor 0805 Surface Mount 0.125W 1% 330R
R113	1M133	Resistor 0805 Surface Mount 0.125W 1% 330R
R114	1M133	Resistor 0805 Surface Mount 0.125W 1% 330R
R115	1M310	Resistor 0805 Surface Mount 0.125W 1% 10K
R116	1M000	Resistor 0805 Surface Mount 0.125W 1% 0R0
R117	1M110	Resistor 0805 Surface Mount 0.125W 1% 100R
R200	1M110	Resistor 0805 Surface Mount 0.125W 1% 100R
R201	1M110	Resistor 0805 Surface Mount 0.125W 1% 100R
R202	1M110	Resistor 0805 Surface Mount 0.125W 1% 100R
R203	1M110	Resistor 0805 Surface Mount 0.125W 1% 100R
R204	1M110	Resistor 0805 Surface Mount 0.125W 1% 100R
R205	1M110	Resistor 0805 Surface Mount 0.125W 1% 100R
R206	1M110	Resistor 0805 Surface Mount 0.125W 1% 100R
R207	1M110	Resistor 0805 Surface Mount 0.125W 1% 100R
R208	1M110	Resistor 0805 Surface Mount 0.125W 1% 100R
R209	1M110	Resistor 0805 Surface Mount 0.125W 1% 100R
R210	1M110	Resistor 0805 Surface Mount 0.125W 1% 100R
R211	1M110	Resistor 0805 Surface Mount 0.125W 1% 100R
R212	1M110	Resistor 0805 Surface Mount 0.125W 1% 100R
R213	1M110	Resistor 0805 Surface Mount 0.125W 1% 100R
R214	1M110	Resistor 0805 Surface Mount 0.125W 1% 100R
R215	1M110	Resistor 0805 Surface Mount 0.125W 1% 100R
R216	1M322	Resistor 0805 Surface Mount 0.125W 1% 22K
R217	1M322	Resistor 0805 Surface Mount 0.125W 1% 22K
R218	1M322	Resistor 0805 Surface Mount 0.125W 1% 22K
R219	1M322	Resistor 0805 Surface Mount 0.125W 1% 22K
R220	1M322	Resistor 0805 Surface Mount 0.125W 1% 22K
R221	1M322	Resistor 0805 Surface Mount 0.125W 1% 22K
R222	1M322	Resistor 0805 Surface Mount 0.125W 1% 22K
R223	1M322	Resistor 0805 Surface Mount 0.125W 1% 22K
R224	1M322	Resistor 0805 Surface Mount 0.125W 1% 22K

C30 Preamplifier 7.1 multichannel cct board L955AY issue 1.0

Designator	Part	Description
R225	1M322	Resistor 0805 Surface Mount 0.125W 1% 22K
R226	1M322	Resistor 0805 Surface Mount 0.125W 1% 22K
R227	1M322	Resistor 0805 Surface Mount 0.125W 1% 22K
R228	1M322	Resistor 0805 Surface Mount 0.125W 1% 22K
R229	1M322	Resistor 0805 Surface Mount 0.125W 1% 22K
R230	1M322	Resistor 0805 Surface Mount 0.125W 1% 22K
R231	1M322	Resistor 0805 Surface Mount 0.125W 1% 22K
R301	1M410	Resistor 0805 Surface Mount 0.125W 1% 100K
R302	1M410	Resistor 0805 Surface Mount 0.125W 1% 100K
R303	1M410	Resistor 0805 Surface Mount 0.125W 1% 100K
R304	1M410	Resistor 0805 Surface Mount 0.125W 1% 100K
R305	1M410	Resistor 0805 Surface Mount 0.125W 1% 100K
R306	1M410	Resistor 0805 Surface Mount 0.125W 1% 100K
R307	1M410	Resistor 0805 Surface Mount 0.125W 1% 100K
R308	1M410	Resistor 0805 Surface Mount 0.125W 1% 100K
R309	1M410	Resistor 0805 Surface Mount 0.125W 1% 100K
R310	1M410	Resistor 0805 Surface Mount 0.125W 1% 100K
R311	1M322	Resistor 0805 Surface Mount 0.125W 1% 22K
R312	1M322	Resistor 0805 Surface Mount 0.125W 1% 22K
R313	1M322	Resistor 0805 Surface Mount 0.125W 1% 22K
R314	1M322	Resistor 0805 Surface Mount 0.125W 1% 22K
R315	1M322	Resistor 0805 Surface Mount 0.125W 1% 22K
R316	1M322	Resistor 0805 Surface Mount 0.125W 1% 22K
R317	1M322	Resistor 0805 Surface Mount 0.125W 1% 22K
R318	1M322	Resistor 0805 Surface Mount 0.125W 1% 22K
R319	1M510	Resistor 0805 Surface Mount 0.125W 1% 1M0
R320	1M510	Resistor 0805 Surface Mount 0.125W 1% 1M0
R321	1M510	Resistor 0805 Surface Mount 0.125W 1% 1M0
R322	1M510	Resistor 0805 Surface Mount 0.125W 1% 1M0
R323	1M510	Resistor 0805 Surface Mount 0.125W 1% 1M0
R324	1M510	Resistor 0805 Surface Mount 0.125W 1% 1M0
R325	1M510	Resistor 0805 Surface Mount 0.125W 1% 1M0
R326	1M510	Resistor 0805 Surface Mount 0.125W 1% 1M0
R400	1M310	Resistor 0805 Surface Mount 0.125W 1% 10K
R401	1M310	Resistor 0805 Surface Mount 0.125W 1% 10K
R402	1M310	Resistor 0805 Surface Mount 0.125W 1% 10K
R403	1M310	Resistor 0805 Surface Mount 0.125W 1% 10K
R404	1M310	Resistor 0805 Surface Mount 0.125W 1% 10K
R405	1M310	Resistor 0805 Surface Mount 0.125W 1% 10K
R406	1M310	Resistor 0805 Surface Mount 0.125W 1% 10K
R407	1M310	Resistor 0805 Surface Mount 0.125W 1% 10K
R408	1M310	Resistor 0805 Surface Mount 0.125W 1% 10K
R409	1M310	Resistor 0805 Surface Mount 0.125W 1% 10K
R410	1M310	Resistor 0805 Surface Mount 0.125W 1% 10K
R411	1M310	Resistor 0805 Surface Mount 0.125W 1% 10K
R412	1M310	Resistor 0805 Surface Mount 0.125W 1% 10K
R413	1M310	Resistor 0805 Surface Mount 0.125W 1% 10K
R414	1M310	Resistor 0805 Surface Mount 0.125W 1% 10K
R415	1M310	Resistor 0805 Surface Mount 0.125W 1% 10K
R416	1M310	Resistor 0805 Surface Mount 0.125W 1% 10K
R417	1M310	Resistor 0805 Surface Mount 0.125W 1% 10K
R418	1M047	Resistor 0805 Surface Mount 0.125W 1% 47R
R419	1M047	Resistor 0805 Surface Mount 0.125W 1% 47R
R420	1M047	Resistor 0805 Surface Mount 0.125W 1% 47R
R421	1M047	Resistor 0805 Surface Mount 0.125W 1% 47R
R422	1M047	Resistor 0805 Surface Mount 0.125W 1% 47R
R423	1M047	Resistor 0805 Surface Mount 0.125W 1% 47R
R424	1M047	Resistor 0805 Surface Mount 0.125W 1% 47R
R425	1M047	Resistor 0805 Surface Mount 0.125W 1% 47R
R440	1M247	Resistor 0805 Surface Mount 0.125W 1% 4K7
R441	1M247	Resistor 0805 Surface Mount 0.125W 1% 4K7

C30 Preamplifier 7.1 multichannel cct board L955AY issue 1.0

Designator	Part	Description
R442	1M000	Resistor 0805 Surface Mount 0.125W 1% 0R0
REG100	5D79L05S	IC Voltage Regulator -5V L79L05ACD SO-8 Package
REG101	5D7805	IC Voltage Regulator +5V L7805CV TO-220 Package
RLY400	A216	Relay 2P2T 5V SM
RLY401	A216	Relay 2P2T 5V SM
RLY402	A216	Relay 2P2T 5V SM
SKT200	8D225	Phono Skt 4-WAY Gold
SKT201	8D225	Phono Skt 4-WAY Gold
SKT202	8D225	Phono Skt 4-WAY Gold
SKT203	8D225	Phono Skt 4-WAY Gold
SKT400	8D226	Phono Skt 2-WAY Vert Gold
SKT401	8D225	Phono Skt 4-WAY Gold
TR400	4A849B	Transistor BC849B SOT23 Package
TR401	4A849B	Transistor BC849B SOT23 Package
X100 NF	7W005	Ceramic Resonator 4.00MHz

C30 Preamplifier PSU/main cct board L958AY issue 2.0

Designator	Part	Description
C1	2K233	Capacitor X1 Y2 Rated Ceramic 7.5mm Pitch 3N3 250V
C2	2K233	Capacitor X1 Y2 Rated Ceramic 7.5mm Pitch 3N3 250V
C3	2K233	Capacitor X1 Y2 Rated Ceramic 7.5mm Pitch 3N3 250V
C4	2K233	Capacitor X1 Y2 Rated Ceramic 7.5mm Pitch 3N3 250V
C5	2D422	Capacitor X2 Boxed Polypropylene 22.5mm Pitch 275V 220NF
C6	2J410	Capacitor SM 0805 X7R Ceramic 10% 50V 100N
C7	2J410	Capacitor SM 0805 X7R Ceramic 10% 50V 100N
C8	2J410	Capacitor SM 0805 X7R Ceramic 10% 50V 100N
C9	2N833	Capacitor Radial Electrolytic Dia 16mm Pitch 7.5mm 3300UF 25V
C10	2P710A	Capacitor Radial Electrolytic Oscon SA 100UF 20V
C11	2P710A	Capacitor Radial Electrolytic Oscon SA 100UF 20V
C12	2P710A	Capacitor Radial Electrolytic Oscon SA 100UF 20V
C13	2P710A	Capacitor Radial Electrolytic Oscon SA 100UF 20V
C14	2N810A	Capacitor Radial Electrolytic Dia 10mm Pitch 5mm 1000UF 10V
C15	2N610	Capacitor Radial Electrolytic Dia 5mm Pitch 5mm 10UF 50V
C16	2J410	Capacitor SM 0805 X7R Ceramic 10% 50V 100N
C17	2KA447	Capacitor Boxed Polyester 5mm Pitch 5% 100VDC 470N
C18	2KA447	Capacitor Boxed Polyester 5mm Pitch 5% 100VDC 470N
C19	2KA447	Capacitor Boxed Polyester 5mm Pitch 5% 100VDC 470N
C20	2KA447	Capacitor Boxed Polyester 5mm Pitch 5% 100VDC 470N
C21	2N910	Capacitor Radial Electrolytic Dia 30mm Claw Mount 10,000UF 50V
C22	2N910	Capacitor Radial Electrolytic Dia 30mm Claw Mount 10,000UF 50V
C23	2J410	Capacitor SM 0805 X7R Ceramic 10% 50V 100N
C24	2J410	Capacitor SM 0805 X7R Ceramic 10% 50V 100N
C25	2J410	Capacitor SM 0805 X7R Ceramic 10% 50V 100N
C26	2J410	Capacitor SM 0805 X7R Ceramic 10% 50V 100N
C27	2J410	Capacitor SM 0805 X7R Ceramic 10% 50V 100N
C28	2J410	Capacitor SM 0805 X7R Ceramic 10% 50V 100N
C29	2J410	Capacitor SM 0805 X7R Ceramic 10% 50V 100N
C30	2J410	Capacitor SM 0805 X7R Ceramic 10% 50V 100N
C31	2J410	Capacitor SM 0805 X7R Ceramic 10% 50V 100N
C32	2J410	Capacitor SM 0805 X7R Ceramic 10% 50V 100N
C33	2N710	Capacitor Radial Electrolytic Dia 5mm Pitch 5mm 100UF 25V
C34	2P622P	Capacitor Radial Electrolytic Oscon SP 22UF 20V
C35	2P622P	Capacitor Radial Electrolytic Oscon SP 22UF 20V
C36	2P622P	Capacitor Radial Electrolytic Oscon SP 22UF 20V
C37	2P622P	Capacitor Radial Electrolytic Oscon SP 22UF 20V
C38	2N710B	Capacitor Radial Electrolytic Dia 10mm Pitch 5mm 100UF 100V
C39	2L110	Capacitor SM 0805 NPO Ceramic 5% 100V 100P
C40	2L115	Capacitor SM 0805 NPO Ceramic 5% 100V 150P
C41	2L115	Capacitor SM 0805 NPO Ceramic 5% 100V 150P
C42	2L168	Capacitor SM 0805 NPO Ceramic 5% 100V 680P
C43	2N810C	Capacitor Radial Electrolytic Dia 12.5mm Pitch 5mm 1000UF 35V
C44	2J410	Capacitor SM 0805 X7R Ceramic 10% 50V 100N
C100	2P710AC	Capacitor Radial Electrolytic Elna ROA Series 100UF 25V
C101	2P710AC	Capacitor Radial Electrolytic Elna ROA Series 100UF 25V
C102	2P710AC	Capacitor Radial Electrolytic Elna ROA Series 100UF 25V
C103	2P710AC	Capacitor Radial Electrolytic Elna ROA Series 100UF 25V
C104	2KA310	Capacitor Boxed Polyester 5mm Pitch 5% 100VDC 10N
C105	2KA310	Capacitor Boxed Polyester 5mm Pitch 5% 100VDC 10N
C106	2KA310	Capacitor Boxed Polyester 5mm Pitch 5% 100VDC 10N
C107	2KA310	Capacitor Boxed Polyester 5mm Pitch 5% 100VDC 10N
C108	2L147	Capacitor SM 0805 NPO Ceramic 5% 100V 470P
C109	2L147	Capacitor SM 0805 NPO Ceramic 5% 100V 470P
C110	2L147	Capacitor SM 0805 NPO Ceramic 5% 100V 470P
C111	2L147	Capacitor SM 0805 NPO Ceramic 5% 100V 470P
C112	2J410	Capacitor SM 0805 X7R Ceramic 10% 50V 100N
C113	2L110	Capacitor SM 0805 NPO Ceramic 5% 100V 100P
C114	2L110	Capacitor SM 0805 NPO Ceramic 5% 100V 100P
C115	2L110	Capacitor SM 0805 NPO Ceramic 5% 100V 100P
C116	2L110	Capacitor SM 0805 NPO Ceramic 5% 100V 100P

C30 Preamplifier PSU/main cct board L958AY issue 2.0

Designator	Part	Description
C117	2JA310	Capacitor SM 0805 X7R Ceramic 10% 100V 10N
C118	2N747	Capacitor Radial Electrolytic Dia 10mm Pitch 5mm 470UF 25V
C119	2N510	Capacitor Radial Electrolytic Dia 5mm Pitch 5mm 1UF 50V
C120	2N510	Capacitor Radial Electrolytic Dia 5mm Pitch 5mm 1UF 50V
C121	2L033	Capacitor SM 0805 NPO Ceramic 5% 100V 33P
C122	2L033	Capacitor SM 0805 NPO Ceramic 5% 100V 33P
C123	2N722	Capacitor Radial Electrolytic Dia 6.3mm Pitch 5mm 220UF 16V
C124	2N722	Capacitor Radial Electrolytic Dia 6.3mm Pitch 5mm 220UF 16V
C125	2N610	Capacitor Radial Electrolytic Dia 5mm Pitch 5mm 10UF 50V
C126	2P710AC	Capacitor Radial Electrolytic Elna ROA Series 100UF 25V
C127	2P710AC	Capacitor Radial Electrolytic Elna ROA Series 100UF 25V
C128	2J410	Capacitor SM 0805 X7R Ceramic 10% 50V 100N
C129	2J410	Capacitor SM 0805 X7R Ceramic 10% 50V 100N
C130	2L110	Capacitor SM 0805 NPO Ceramic 5% 100V 100P
C131	2L110	Capacitor SM 0805 NPO Ceramic 5% 100V 100P
C132	2L110	Capacitor SM 0805 NPO Ceramic 5% 100V 100P
C133	2JA310	Capacitor SM 0805 X7R Ceramic 10% 100V 10N
C134	2P710AC	Capacitor Radial Electrolytic Elna ROA Series 100UF 25V
C135	2P710AC	Capacitor Radial Electrolytic Elna ROA Series 100UF 25V
C136	2J410	Capacitor SM 0805 X7R Ceramic 10% 50V 100N
C137	2J410	Capacitor SM 0805 X7R Ceramic 10% 50V 100N
C138	2L110	Capacitor SM 0805 NPO Ceramic 5% 100V 100P
C139	2L110	Capacitor SM 0805 NPO Ceramic 5% 100V 100P
C140	2L110	Capacitor SM 0805 NPO Ceramic 5% 100V 100P
C141	2JA310	Capacitor SM 0805 X7R Ceramic 10% 100V 10N
CON1	8Q003	Con Cage Clamp 1WAY
CON2	8K2308	Con Minifit HCS 8WAY
CON3	8K2306	Con Minifit HCS 6WAY
CON4	8K2304	Con Minifit HCS 4WAY
CON5	8K6604	Con KK Series 0.1in Vertical Friction Lock Hdr 4WAY
CON6	8K6604	Con KK Series 0.1in Vertical Friction Lock Hdr 4WAY
CON7	8K6604	Con KK Series 0.1in Vertical Friction Lock Hdr 4WAY
CON8	8K7014	Con 2.54MM Vertical FFC 14WAY
CON100	8K2404	Con CT Series Vertical 4WAY
CON101	8K2406	Con CT Series Vertical 6WAY
CON102	8K2406	Con CT Series Vertical 6WAY
CON103	8K3101	XLR PCB Male Neutrik NC3MBH-B
CON104	8K3101	XLR PCB Male Neutrik NC3MBH-B
D1	3F5819	Diode Schottky 1N5819 DO-41 Package
D2	3F5819	Diode Schottky 1N5819 DO-41 Package
D3	3F5819	Diode Schottky 1N5819 DO-41 Package
D4	3F5819	Diode Schottky 1N5819 DO-41 Package
D5	3AS16W	Diode Surface Mount Small Signal BAS16W SOT-23 Package
D6	3AS16W	Diode Surface Mount Small Signal BAS16W SOT-23 Package
D7	3AS16W	Diode Surface Mount Small Signal BAS16W SOT-23 Package
D8	3AS16W	Diode Surface Mount Small Signal BAS16W SOT-23 Package
D9	3AS16W	Diode Surface Mount Small Signal BAS16W SOT-23 Package
D10	3AS16W	Diode Surface Mount Small Signal BAS16W SOT-23 Package
D11	3AS16W	Diode Surface Mount Small Signal BAS16W SOT-23 Package
D12	3AS16W	Diode Surface Mount Small Signal BAS16W SOT-23 Package
D13	3AS16W	Diode Surface Mount Small Signal BAS16W SOT-23 Package
D14	3AS16W	Diode Surface Mount Small Signal BAS16W SOT-23 Package
D15	3AS16W	Diode Surface Mount Small Signal BAS16W SOT-23 Package
D16	3AS16W	Diode Surface Mount Small Signal BAS16W SOT-23 Package
D17	3BYV27	Diode SBYV27-200 DO-15 Package
D18	3BYV27	Diode SBYV27-200 DO-15 Package
D19	3BYV27	Diode SBYV27-200 DO-15 Package
D20	3BYV27	Diode SBYV27-200 DO-15 Package
D21	3BYV27	Diode SBYV27-200 DO-15 Package
D22	3BYV27	Diode SBYV27-200 DO-15 Package
D23	3BYV27	Diode SBYV27-200 DO-15 Package

C30 Preamplifier PSU/main cct board L958AY issue 2.0

Designator	Part	Description
D24	3BYV27	Diode SBYV27-200 DO-15 Package
D25	3AS16W	Diode Surface Mount Small Signal BAS16W SOT-23 Package
D100	3AV99W	Diode Dual Surface Mount Small Signal BAV99 SOT-23 Package
D101	3AV99W	Diode Dual Surface Mount Small Signal BAV99 SOT-23 Package
D102	3AV99W	Diode Dual Surface Mount Small Signal BAV99 SOT-23 Package
D103	3AV99W	Diode Dual Surface Mount Small Signal BAV99 SOT-23 Package
D104	3AS16W	Diode Surface Mount Small Signal BAS16W SOT-23 Package
D105	3AV99W	Diode Dual Surface Mount Small Signal BAV99 SOT-23 Package
D106	3AV99W	Diode Dual Surface Mount Small Signal BAV99 SOT-23 Package
D107	3AV99W	Diode Dual Surface Mount Small Signal BAV99 SOT-23 Package
D108	3AV99W	Diode Dual Surface Mount Small Signal BAV99 SOT-23 Package
DBR1	3BW02	Diode Bridge Rectifier W02G Plastic Package
DBR2	3BW02	Diode Bridge Rectifier W02G Plastic Package
DZ1	3CW32V7	Zener Diode 0.25W Surface Mount BZX84C2V7 SOT-23 Package
DZ2	3CW315V	Zener Diode 0.25W Surface Mount BZX84C15V SOT-23 Package
DZ3	3CW33V9	Zener Diode 0.25W Surface Mount BZX84C3V9 SOT-23 Package
FHLDR1	8S004	Fuseholder 20MM PCB
FHLDR2	8S004	Fuseholder 20MM PCB
FHLDR3	8S004	Fuseholder 20MM PCB
FHLDR4	8S004	Fuseholder 20MM PCB
FS3	C54125	Fuse Bussmann S504 T250mA
FS4	C54125	Fuse Bussmann S504 T250mA
FS5	C3501	Fuse Littelfuse T500mA SM
HS1	F008	Heatsink TO-220 SW50-2 8.8 Deg C/W
HS2	F008	Heatsink TO-220 SW50-2 8.8 Deg C/W
HS3	F008	Heatsink TO-220 SW50-2 8.8 Deg C/W
HS4	F004	Heatsink TO-220 PF752 23.7 Degc/W
HS5	F008	Heatsink TO-220 SW50-2 8.8 Deg C/W
HS6	F008	Heatsink TO-220 SW50-2 8.8 Deg C/W
IC1	5B972	Opamp TS972ID SO-8 Package
IC100	5B797	Opamp AD797AR SO-8 Package
IC101	5B797	Opamp AD797AR SO-8 Package
IC102	5A4880	IC Headphone Amp Nat Semi LM4880M SO-8 Package
IC103	5B135	IC Balanced Driver Burr-Brown DRV135UA SO-8 Package
IC104	5B135	IC Balanced Driver Burr-Brown DRV135UA SO-8 Package
ITEM1-1	L958PB	Blank PCB C30 Preamp PSU
ITEM2-1	F006	Clip For SW Profile Heatsink
ITEM3-1	F006	Clip For SW Profile Heatsink
ITEM4-1	F006	Clip For SW Profile Heatsink
ITEM6-1	F006	Clip For SW Profile Heatsink
ITEM7-1	F006	Clip For SW Profile Heatsink
ITEM8-1	E802AP	Pad Damping 15x6x3MM Sorbothane
ITEM9-1	E826AP	Pad Damping 7.5x6x3 Sorbothane
ITEM10-1	E826AP	Pad Damping 7.5x6x3 Sorbothane
ITEM11-1	E826AP	Pad Damping 7.5x6x3 Sorbothane
ITEM12-1	E826AP	Pad Damping 7.5x6x3 Sorbothane
ITEM13-1	F022	Fuseholder Cover For 20mm Fuseholder
ITEM14-1	F022	Fuseholder Cover For 20mm Fuseholder
ITEM15-1	F022	Fuseholder Cover For 20mm Fuseholder
ITEM16-1	F022	Fuseholder Cover For 20mm Fuseholder
ITEM17-1	8M101	Earth Lead Assy 75MM
L1	7F004	Ferrite Bead SM1206 70R@100MHz
L100	7F004	Ferrite Bead SM1206 70R@100MHz
L101	7F004	Ferrite Bead SM1206 70R@100MHz
OPTO1	5T4N35	Opto Isolator 4N35
R1	1KA515	Resistor Metal Glazed 0.5W 5% 1M5
R2	1M000	Resistor 0805 Surface Mount 0.125W 1% 0R0
R3	1M127	Resistor 0805 Surface Mount 0.125W 1% 270R
R4	1M168	Resistor 0805 Surface Mount 0.125W 1% 680R
R5	1M222	Resistor 0805 Surface Mount 0.125W 1% 2K2
R6	1M222	Resistor 0805 Surface Mount 0.125W 1% 2K2

C30 Preamplifier PSU/main cct board L958AY issue 2.0

Designator	Part	Description
R7	1M222	Resistor 0805 Surface Mount 0.125W 1% 2K2
R8	1M222	Resistor 0805 Surface Mount 0.125W 1% 2K2
R9	1M222	Resistor 0805 Surface Mount 0.125W 1% 2K2
R10	1M222	Resistor 0805 Surface Mount 0.125W 1% 2K2
R11	1M310	Resistor 0805 Surface Mount 0.125W 1% 10K
R12	1M310	Resistor 0805 Surface Mount 0.125W 1% 10K
R13	1M310	Resistor 0805 Surface Mount 0.125W 1% 10K
R14	1M233	Resistor 0805 Surface Mount 0.125W 1% 3K3
R15	1M233	Resistor 0805 Surface Mount 0.125W 1% 3K3
R16	1M233	Resistor 0805 Surface Mount 0.125W 1% 3K3
R17	1M068	Resistor 0805 Surface Mount 0.125W 1% 68R
R18	1M068	Resistor 0805 Surface Mount 0.125W 1% 68R
R19	1M110	Resistor 0805 Surface Mount 0.125W 1% 100R
R20	1M110	Resistor 0805 Surface Mount 0.125W 1% 100R
R21	1M110	Resistor 0805 Surface Mount 0.125W 1% 100R
R22	1M110	Resistor 0805 Surface Mount 0.125W 1% 100R
R23	1M110	Resistor 0805 Surface Mount 0.125W 1% 100R
R24	1M110	Resistor 0805 Surface Mount 0.125W 1% 100R
R25	1M010	Resistor 0805 Surface Mount 0.125W 1% 10R
R26	1M233	Resistor 0805 Surface Mount 0.125W 1% 3K3
R27	1M010	Resistor 0805 Surface Mount 0.125W 1% 10R
R28	1M322	Resistor 0805 Surface Mount 0.125W 1% 22K
R29	1M427	Resistor 0805 Surface Mount 0.125W 1% 270K
R30	1M212	Resistor 0805 Surface Mount 0.125W 1% 1K2
R31	1M218	Resistor 0805 Surface Mount 0.125W 1% 1K8
R32	1M468	Resistor 0805 Surface Mount 0.125W 1% 680K
R33	1M447	Resistor 0805 Surface Mount 0.125W 1% 470K
R34	1M215	Resistor 0805 Surface Mount 0.125W 1% 1K5
R35	1M247	Resistor 0805 Surface Mount 0.125W 1% 4K7
R36	1M268	Resistor 0805 Surface Mount 0.125W 1% 6K8
R37	1M000	Resistor 0805 Surface Mount 0.125W 1% 0R0
R38	1M000	Resistor 0805 Surface Mount 0.125W 1% 0R0
R39	1M147	Resistor 0805 Surface Mount 0.125W 1% 470R
R100	1M110	Resistor 0805 Surface Mount 0.125W 1% 100R
R101	1M110	Resistor 0805 Surface Mount 0.125W 1% 100R
R102	1M110	Resistor 0805 Surface Mount 0.125W 1% 100R
R103	1M110	Resistor 0805 Surface Mount 0.125W 1% 100R
R104	1M047	Resistor 0805 Surface Mount 0.125W 1% 47R
R105	1M047	Resistor 0805 Surface Mount 0.125W 1% 47R
R106	1M315	Resistor 0805 Surface Mount 0.125W 1% 15K
R107	1M315	Resistor 0805 Surface Mount 0.125W 1% 15K
R108	1M822	Resistor 0805 Surface Mount 0.125W 1% 2R2
R109	1M310	Resistor 0805 Surface Mount 0.125W 1% 10K
R110	1M310	Resistor 0805 Surface Mount 0.125W 1% 10K
R111	1M347	Resistor 0805 Surface Mount 0.125W 1% 47K
R112	1M347	Resistor 0805 Surface Mount 0.125W 1% 47K
R113	1E847	Resistor Carbon Film 1W 5% 4R7
R114	1E847	Resistor Carbon Film 1W 5% 4R7
R115	1M115	Resistor 0805 Surface Mount 0.125W 1% 150R
R116	1M410	Resistor 0805 Surface Mount 0.125W 1% 100K
R117	1M410	Resistor 0805 Surface Mount 0.125W 1% 100K
R118	1M310	Resistor 0805 Surface Mount 0.125W 1% 10K
R119	1M310	Resistor 0805 Surface Mount 0.125W 1% 10K
R120	1M047	Resistor 0805 Surface Mount 0.125W 1% 47R
R121	1M047	Resistor 0805 Surface Mount 0.125W 1% 47R
R122	1M047	Resistor 0805 Surface Mount 0.125W 1% 47R
R123	1M047	Resistor 0805 Surface Mount 0.125W 1% 47R
R124	1M115	Resistor 0805 Surface Mount 0.125W 1% 150R
R125	1M010	Resistor 0805 Surface Mount 0.125W 1% 10R
R1000	1H210	Resistor Metal Film 0.25W 1% 1K0
REG4	5D7805	IC Voltage Regulator +5V L7805CV TO-220 Package

C30 Preamplifier PSU/main cct board L958AY issue 2.0

Designator	Part	Description
REG3	5D317T	IC Voltage Regulator ADJ LM317T TO-220 Package
REG2	5D317T	IC Voltage Regulator ADJ LM317T TO-220 Package
REG5	5D337	IC Voltage Regulator Neg ADJ LM337T TO-220 Package
REG6	5D337	IC Voltage Regulator Neg ADJ LM337T TO-220 Package
REG1	5D1086A	IC Voltage Regulator ADJ LM1086CT-ADJ TO-220 Package
RLY1	A219	Relay 2P2T 5V
RLY100	A215	Relay 2P2T 12V SM
RLY101	A215	Relay 2P2T 12V SM
RLY102	A215	Relay 2P2T 12V SM
RLY103	A215	Relay 2P2T 12V SM
SH1	E5402	Shield EMC IEC Inlet Mains
SKT1	8A001	Mains IEC Inlet 3PIN PCB Ins
SKT2	8D302	Con Jack 3.5mm Dual Mono
SKT100	8D225	Phono Skt 4-WAY Gold
SKT101	8D301	Con Jack 6mm Stereo
SW1	A1404	Switch Slide Volt Sel
TX1	7A9301	Transformer PCB mount 9V+9V 3VA 115/230V
TX1	L907TX	Transformer PCB mount 9V+9V 3VA 100V
TR1	4A849B	Transistor BC849B SOT23 Package
TR2	4A849B	Transistor BC849B SOT23 Package
TR3	4AFMMT497	Transistor FMMT497 SOT23 Package
TR4	4B179	Transistor BD179 TO126 Package
TR5	4AFMMT497	Transistor FMMT497 SOT23 Package
TR6	4D10KN	Digital Transistor MMUN2211LT1 SOT23 Package
TR100	4B179	Transistor BD179 TO126 Package

C30 Preamplifier pre-amp cct board L965AY issue 1.2

Designator	Part	Description
C100	2C210	Capacitor SM 1206 NPO Ceramic 50V 5% 1N0
C101	2DA147	Capacitor Boxed Polypropylene 5mm Pitch 100V 5% 470P
C102	2DA147	Capacitor Boxed Polypropylene 5mm Pitch 100V 5% 470P
C103	2DA147	Capacitor Boxed Polypropylene 5mm Pitch 100V 5% 470P
C104	2C410	Capacitor SM 1206 X7R Ceramic 50V 10% 100N
C105	2C410	Capacitor SM 1206 X7R Ceramic 50V 10% 100N
C106	2C410	Capacitor SM 1206 X7R Ceramic 50V 10% 100N
C107	2C410	Capacitor SM 1206 X7R Ceramic 50V 10% 100N
C108	2C110	Capacitor SM 1206 NPO Ceramic 50V 5% 100PF
C109	2C110	Capacitor SM 1206 NPO Ceramic 50V 5% 100PF
C110	2N710	Capacitor Radial Electrolytic Dia 5mm Pitch 5mm 100UF 25V
C111	2P610CC	Capacitor Radial Electrolytic Elna ROA 10UF 50V
C112	2K447	Capacitor Boxed Polyester 5mm Pitch 10% 63V 470N
C113	2K447	Capacitor Boxed Polyester 5mm Pitch 10% 63V 470N
C114	2D222W	Capacitor Boxed Polyprop 5mm Pitch 100V 5% 2N2
C115	2C022	Capacitor SM 1206 NPO Ceramic 100V 5% 22PF
C116	2P610CC	Capacitor Radial Electrolytic Elna ROA 10UF 50V
C117	2P610CC	Capacitor Radial Electrolytic Elna ROA 10UF 50V
C118	2C410	Capacitor SM 1206 X7R Ceramic 50V 10% 100N
C119	2C310	Capacitor SM 1206 X7R Ceramic 50V 10% 10NF
C120	2N610	Capacitor Radial Electrolytic Dia 5mm Pitch 5mm 10UF 50V
C121	2C210	Capacitor SM 1206 NPO Ceramic 50V 5% 1N0
C122	2DA147	Capacitor Boxed Polypropylene 5mm Pitch 100V 5% 470P
C123	2DA147	Capacitor Boxed Polypropylene 5mm Pitch 100V 5% 470P
C124	2DA147	Capacitor Boxed Polypropylene 5mm Pitch 100V 5% 470P
C125	2C410	Capacitor SM 1206 X7R Ceramic 50V 10% 100N
C126	2C410	Capacitor SM 1206 X7R Ceramic 50V 10% 100N
C127	2C410	Capacitor SM 1206 X7R Ceramic 50V 10% 100N
C128	2C410	Capacitor SM 1206 X7R Ceramic 50V 10% 100N
C129	2C110	Capacitor SM 1206 NPO Ceramic 50V 5% 100PF
C130	2C110	Capacitor SM 1206 NPO Ceramic 50V 5% 100PF
C131	2N710	Capacitor Radial Electrolytic Dia 5mm Pitch 5mm 100UF 25V
C132	2P610CC	Capacitor Radial Electrolytic Elna ROA 10UF 50V
C133	2K447	Capacitor Boxed Polyester 5mm Pitch 10% 63V 470N
C134	2K447	Capacitor Boxed Polyester 5mm Pitch 10% 63V 470N
C135	2D222W	Capacitor Boxed Polyprop 5mm Pitch 100V 5% 2N2
C136	2C022	Capacitor SM 1206 NPO Ceramic 100V 5% 22PF
C137	2P610CC	Capacitor Radial Electrolytic Elna ROA 10UF 50V
C138	2P610CC	Capacitor Radial Electrolytic Elna ROA 10UF 50V
C139	2C210	Capacitor SM 1206 NPO Ceramic 50V 5% 1N0
C140	2DA147	Capacitor Boxed Polypropylene 5mm Pitch 100V 5% 470P
C141	2DA147	Capacitor Boxed Polypropylene 5mm Pitch 100V 5% 470P
C142	2DA147	Capacitor Boxed Polypropylene 5mm Pitch 100V 5% 470P
C143	2C410	Capacitor SM 1206 X7R Ceramic 50V 10% 100N
C144	2C410	Capacitor SM 1206 X7R Ceramic 50V 10% 100N
C145	2C410	Capacitor SM 1206 X7R Ceramic 50V 10% 100N
C146	2C410	Capacitor SM 1206 X7R Ceramic 50V 10% 100N
C147	2KA410	Capacitor Boxed Polyester 5mm Pitch 5% 100VDC 100N
C148	2C022	Capacitor SM 1206 NPO Ceramic 100V 5% 22PF
C149	2C022	Capacitor SM 1206 NPO Ceramic 100V 5% 22PF
C150	2K447	Capacitor Boxed Polyester 5mm Pitch 10% 63V 470N
C151	2K447	Capacitor Boxed Polyester 5mm Pitch 10% 63V 470N
C152	2C410	Capacitor SM 1206 X7R Ceramic 50V 10% 100N
C153	2C410	Capacitor SM 1206 X7R Ceramic 50V 10% 100N
C154	2P622P	Capacitor Radial Electrolytic Oscon SP 22UF 20V
C155	2C410	Capacitor SM 1206 X7R Ceramic 50V 10% 100N
C156	2C410	Capacitor SM 1206 X7R Ceramic 50V 10% 100N
C157	2P622P	Capacitor Radial Electrolytic Oscon SP 22UF 20V
C158	2C022	Capacitor SM 1206 NPO Ceramic 100V 5% 22PF
C159	2C022	Capacitor SM 1206 NPO Ceramic 100V 5% 22PF
C160	2C210	Capacitor SM 1206 NPO Ceramic 50V 5% 1N0

C30 Preamplifier pre-amp cct board L965AY issue 1.2

Designator	Part	Description
C161	2DA147	Capacitor Boxed Polypropylene 5mm Pitch 100V 5% 470P
C162	2DA147	Capacitor Boxed Polypropylene 5mm Pitch 100V 5% 470P
C163	2DA147	Capacitor Boxed Polypropylene 5mm Pitch 100V 5% 470P
C164	2C210	Capacitor SM 1206 NPO Ceramic 50V 5% 1N0
C165	2DA147	Capacitor Boxed Polypropylene 5mm Pitch 100V 5% 470P
C166	2DA147	Capacitor Boxed Polypropylene 5mm Pitch 100V 5% 470P
C167	2KA410	Capacitor Boxed Polyester 5mm Pitch 5% 100VDC 100N
C168	2C410	Capacitor SM 1206 X7R Ceramic 50V 10% 100N
C169	2C410	Capacitor SM 1206 X7R Ceramic 50V 10% 100N
C170	2C410	Capacitor SM 1206 X7R Ceramic 50V 10% 100N
C171	2C410	Capacitor SM 1206 X7R Ceramic 50V 10% 100N
C172	2C410	Capacitor SM 1206 X7R Ceramic 50V 10% 100N
C173	2C410	Capacitor SM 1206 X7R Ceramic 50V 10% 100N
C174	2C410	Capacitor SM 1206 X7R Ceramic 50V 10% 100N
C175	2C410	Capacitor SM 1206 X7R Ceramic 50V 10% 100N
C176	2C410	Capacitor SM 1206 X7R Ceramic 50V 10% 100N
C177	2C410	Capacitor SM 1206 X7R Ceramic 50V 10% 100N
C178	2C410	Capacitor SM 1206 X7R Ceramic 50V 10% 100N
C179	2C410	Capacitor SM 1206 X7R Ceramic 50V 10% 100N
C180	2C410	Capacitor SM 1206 X7R Ceramic 50V 10% 100N
C181	2C410	Capacitor SM 1206 X7R Ceramic 50V 10% 100N
C182	2C410	Capacitor SM 1206 X7R Ceramic 50V 10% 100N
C183	2C410	Capacitor SM 1206 X7R Ceramic 50V 10% 100N
C184	2C410	Capacitor SM 1206 X7R Ceramic 50V 10% 100N
C185	2C410	Capacitor SM 1206 X7R Ceramic 50V 10% 100N
C186	2C410	Capacitor SM 1206 X7R Ceramic 50V 10% 100N
C187	2N610	Capacitor Radial Electrolytic Dia 5mm Pitch 5mm 10UF 50V
C188	2P622P	Capacitor Radial Electrolytic Oscon SP 22UF 20V
C189	2P622P	Capacitor Radial Electrolytic Oscon SP 22UF 20V
C190	2P622P	Capacitor Radial Electrolytic Oscon SP 22UF 20V
C191	2P622P	Capacitor Radial Electrolytic Oscon SP 22UF 20V
C192	2K447	Capacitor Boxed Polyester 5mm Pitch 10% 63V 470N
C193	2K447	Capacitor Boxed Polyester 5mm Pitch 10% 63V 470N
C300	2N810C	Capacitor Radial Electrolytic Dia 12.5mm Pitch 5mm 1000UF 35V
C302	2P622P	Capacitor Radial Electrolytic Oscon SP 22UF 20V
C303	2P710A	Capacitor Radial Electrolytic Oscon SA 100UF 20V
C304	2C410	Capacitor SM 1206 X7R Ceramic 50V 10% 100N
C305	2KA410	Capacitor Boxed Polyester 5mm Pitch 5% 100VDC 100N
C306	2P710A	Capacitor Radial Electrolytic Oscon SA 100UF 20V
C307	2K447	Capacitor Boxed Polyester 5mm Pitch 10% 63V 470N
C308	2C410	Capacitor SM 1206 X7R Ceramic 50V 10% 100N
C309	2C410	Capacitor SM 1206 X7R Ceramic 50V 10% 100N
C310	2N810C	Capacitor Radial Electrolytic Dia 12.5mm Pitch 5mm 1000UF 35V
C312	2P622P	Capacitor Radial Electrolytic Oscon SP 22UF 20V
C313	2P710A	Capacitor Radial Electrolytic Oscon SA 100UF 20V
C314	2KA410	Capacitor Boxed Polyester 5mm Pitch 5% 100VDC 100N
C315	2KA410	Capacitor Boxed Polyester 5mm Pitch 5% 100VDC 100N
D100	3AV99W	Diode Dual Surface Mount Small Signal BAV99 SOT-23 Package
D101	3AV99W	Diode Dual Surface Mount Small Signal BAV99 SOT-23 Package
D102	3AV99W	Diode Dual Surface Mount Small Signal BAV99 SOT-23 Package
D103	3AV99W	Diode Dual Surface Mount Small Signal BAV99 SOT-23 Package
D104	3AV99W	Diode Dual Surface Mount Small Signal BAV99 SOT-23 Package
D105	3AV99W	Diode Dual Surface Mount Small Signal BAV99 SOT-23 Package
D106	3AV99W	Diode Dual Surface Mount Small Signal BAV99 SOT-23 Package
D107	3AV99W	Diode Dual Surface Mount Small Signal BAV99 SOT-23 Package
D108	3AV99W	Diode Dual Surface Mount Small Signal BAV99 SOT-23 Package
D109	3AV99W	Diode Dual Surface Mount Small Signal BAV99 SOT-23 Package
D110	3AV99W	Diode Dual Surface Mount Small Signal BAV99 SOT-23 Package
D111	3AV99W	Diode Dual Surface Mount Small Signal BAV99 SOT-23 Package
D112	3AV99W	Diode Dual Surface Mount Small Signal BAV99 SOT-23 Package
D113	3AV99W	Diode Dual Surface Mount Small Signal BAV99 SOT-23 Package

C30 Preamplifier pre-amp cct board L965AY issue 1.2

Designator	Part	Description
D114	3AV99W	Diode Dual Surface Mount Small Signal BAV99 SOT-23 Package
D115	3AV99W	Diode Dual Surface Mount Small Signal BAV99 SOT-23 Package
D116	3AV99W	Diode Dual Surface Mount Small Signal BAV99 SOT-23 Package
D117	3AV99W	Diode Dual Surface Mount Small Signal BAV99 SOT-23 Package
D118	3AV99W	Diode Dual Surface Mount Small Signal BAV99 SOT-23 Package
D119	3AV99W	Diode Dual Surface Mount Small Signal BAV99 SOT-23 Package
D120	3AS16W	Diode Surface Mount Small Signal BAS16W SOT-23 Package
D121	3AV99W	Diode Dual Surface Mount Small Signal BAV99 SOT-23 Package
D122	3AV99W	Diode Dual Surface Mount Small Signal BAV99 SOT-23 Package
D300	3BS1D	Diode Surface Mount S1D
D301	3BS1D	Diode Surface Mount S1D
D302	3AS16W	Diode Surface Mount Small Signal BAS16W SOT-23 Package
D304	3AS16W	Diode Surface Mount Small Signal BAS16W SOT-23 Package
D305	3AS16W	Diode Surface Mount Small Signal BAS16W SOT-23 Package
D306	3BS1D	Diode Surface Mount S1D
D307	3BS1D	Diode Surface Mount S1D
D308	3AS16W	Diode Surface Mount Small Signal BAS16W SOT-23 Package
D310	3CW315V	Zener Diode 0.25W Surface Mount BZX84C15V SOT-23 Package
D311	3CW315V	Zener Diode 0.25W Surface Mount BZX84C15V SOT-23 Package
F300	C3202	Fuse Littelfuse T2A SM
F301	C3202	Fuse Littelfuse T2A SM
ITEM1-1	E826AP	Pad Damping 7.5x6x3 Sorbothane
ITEM2-1	E826AP	Pad Damping 7.5x6x3 Sorbothane
PCB1	L937PB	Blank PCB A32 Preamp PCB
Q100	4A849B	Transistor BC849B SOT23 Package
Q300	4J112	Transistor Jfet N Channel J112 TO-92 Package
Q301	4B5171	Transistor 2SC5171 TO220 Package
Q303	4J112	Transistor Jfet N Channel J112 TO-92 Package
Q305	4B1930	Transistor 2SA1930 TO220 Package
Q306	4A846B	Transistor BC846B SOT23 Package
Q307	4A856B	Transistor BC856B SOT23 Package
R100	1A210	Resistor 1206 Surface Mount 0.25W 1% 1K0
R101	1A210	Resistor 1206 Surface Mount 0.25W 1% 1K0
R102	1A210	Resistor 1206 Surface Mount 0.25W 1% 1K0
R103	1A410	Resistor 1206 Surface Mount 0.25W 1% 100K
R104	1A410	Resistor 1206 Surface Mount 0.25W 1% 100K
R105	1A410	Resistor 1206 Surface Mount 0.25W 1% 100K
R106	1A510	Resistor 1206 Surface Mount 0.25W 1% 1M0
R107	1A510	Resistor 1206 Surface Mount 0.25W 1% 1M0
R108	1A047	Resistor 1206 Surface Mount 0.25W 1% 47R
R109	1A047	Resistor 1206 Surface Mount 0.25W 1% 47R
R110	1A222	Resistor 1206 Surface Mount 0.25W 1% 2K2
R111	1A222	Resistor 1206 Surface Mount 0.25W 1% 2K2
R112	1A322	Resistor 1206 Surface Mount 0.25W 1% 22K
R113	1A322	Resistor 1206 Surface Mount 0.25W 1% 22K
R114	1A322	Resistor 1206 Surface Mount 0.25W 1% 22K
R115	1A227	Resistor 1206 Surface Mount 0.25W 1% 2K7
R116	1A227	Resistor 1206 Surface Mount 0.25W 1% 2K7
R117	1A256	Resistor 1206 Surface Mount 0.25W 1% 5K6
R118	1A322	Resistor 1206 Surface Mount 0.25W 1% 22K
R119	1A322	Resistor 1206 Surface Mount 0.25W 1% 22K
R120	1A322	Resistor 1206 Surface Mount 0.25W 1% 22K
R121	1A322	Resistor 1206 Surface Mount 0.25W 1% 22K
R122	1A822	Resistor 1206 Surface Mount 0.25W 1% 2R2
R123	1A822	Resistor 1206 Surface Mount 0.25W 1% 2R2
R124	1A822	Resistor 1206 Surface Mount 0.25W 1% 2R2
R125	1A210	Resistor 1206 Surface Mount 0.25W 1% 1K0
R126	1A210	Resistor 1206 Surface Mount 0.25W 1% 1K0
R127	1A210	Resistor 1206 Surface Mount 0.25W 1% 1K0
R128	1A410	Resistor 1206 Surface Mount 0.25W 1% 100K
R129	1A410	Resistor 1206 Surface Mount 0.25W 1% 100K

C30 Preamplifier pre-amp cct board L965AY issue 1.2

Designator	Part	Description
R130	1A410	Resistor 1206 Surface Mount 0.25W 1% 100K
R131	1A510	Resistor 1206 Surface Mount 0.25W 1% 1M0
R132	1A510	Resistor 1206 Surface Mount 0.25W 1% 1M0
R133	1A047	Resistor 1206 Surface Mount 0.25W 1% 47R
R134	1A047	Resistor 1206 Surface Mount 0.25W 1% 47R
R135	1A222	Resistor 1206 Surface Mount 0.25W 1% 2K2
R136	1A222	Resistor 1206 Surface Mount 0.25W 1% 2K2
R137	1A322	Resistor 1206 Surface Mount 0.25W 1% 22K
R138	1A322	Resistor 1206 Surface Mount 0.25W 1% 22K
R139	1A322	Resistor 1206 Surface Mount 0.25W 1% 22K
R140	1A227	Resistor 1206 Surface Mount 0.25W 1% 2K7
R141	1A227	Resistor 1206 Surface Mount 0.25W 1% 2K7
R142	1A256	Resistor 1206 Surface Mount 0.25W 1% 5K6
R143	1A322	Resistor 1206 Surface Mount 0.25W 1% 22K
R144	1A322	Resistor 1206 Surface Mount 0.25W 1% 22K
R145	1A322	Resistor 1206 Surface Mount 0.25W 1% 22K
R146	1A322	Resistor 1206 Surface Mount 0.25W 1% 22K
R147	1A322	Resistor 1206 Surface Mount 0.25W 1% 22K
R148	1A322	Resistor 1206 Surface Mount 0.25W 1% 22K
R149	1A322	Resistor 1206 Surface Mount 0.25W 1% 22K
R150	1A322	Resistor 1206 Surface Mount 0.25W 1% 22K
R151	1A322	Resistor 1206 Surface Mount 0.25W 1% 22K
R152	1A322	Resistor 1206 Surface Mount 0.25W 1% 22K
R153	1A322	Resistor 1206 Surface Mount 0.25W 1% 22K
R154	1A322	Resistor 1206 Surface Mount 0.25W 1% 22K
R155	1A322	Resistor 1206 Surface Mount 0.25W 1% 22K
R156	1A210	Resistor 1206 Surface Mount 0.25W 1% 1K0
R157	1A210	Resistor 1206 Surface Mount 0.25W 1% 1K0
R158	1A210	Resistor 1206 Surface Mount 0.25W 1% 1K0
R159	1A410	Resistor 1206 Surface Mount 0.25W 1% 100K
R160	1A410	Resistor 1206 Surface Mount 0.25W 1% 100K
R161	1A410	Resistor 1206 Surface Mount 0.25W 1% 100K
R162	1A322	Resistor 1206 Surface Mount 0.25W 1% 22K
R163	1A322	Resistor 1206 Surface Mount 0.25W 1% 22K
R164	1A322	Resistor 1206 Surface Mount 0.25W 1% 22K
R165	1A322	Resistor 1206 Surface Mount 0.25W 1% 22K
R166	1A322	Resistor 1206 Surface Mount 0.25W 1% 22K
R167	1A322	Resistor 1206 Surface Mount 0.25W 1% 22K
R168	1A322	Resistor 1206 Surface Mount 0.25W 1% 22K
R169	1A322	Resistor 1206 Surface Mount 0.25W 1% 22K
R170	1A322	Resistor 1206 Surface Mount 0.25W 1% 22K
R171	1A322	Resistor 1206 Surface Mount 0.25W 1% 22K
R172	1A322	Resistor 1206 Surface Mount 0.25W 1% 22K
R173	1A322	Resistor 1206 Surface Mount 0.25W 1% 22K
R174	1A322	Resistor 1206 Surface Mount 0.25W 1% 22K
R175	1A322	Resistor 1206 Surface Mount 0.25W 1% 22K
R176	1A322	Resistor 1206 Surface Mount 0.25W 1% 22K
R177	1A322	Resistor 1206 Surface Mount 0.25W 1% 22K
R178	1A322	Resistor 1206 Surface Mount 0.25W 1% 22K
R179	1A322	Resistor 1206 Surface Mount 0.25W 1% 22K
R180	1A410	Resistor 1206 Surface Mount 0.25W 1% 100K
R181	1A310	Resistor 1206 Surface Mount 0.25W 1% 10K
R182	1A110	Resistor 1206 Surface Mount 0.25W 1% 100R
R183	1A510	Resistor 1206 Surface Mount 0.25W 1% 1M0
R184	1A510	Resistor 1206 Surface Mount 0.25W 1% 1M0
R185	1A022	Resistor 1206 Surface Mount 0.25W 1% 22R
R186	1A047	Resistor 1206 Surface Mount 0.25W 1% 47R
R187	1A047	Resistor 1206 Surface Mount 0.25W 1% 47R
R188	1A310	Resistor 1206 Surface Mount 0.25W 1% 10K
R189	1A210	Resistor 1206 Surface Mount 0.25W 1% 1K0
R190	1A210	Resistor 1206 Surface Mount 0.25W 1% 1K0

C30 Preamplifier pre-amp cct board L965AY issue 1.2

Designator	Part	Description
R191	1A210	Resistor 1206 Surface Mount 0.25W 1% 1K0
R192	1A410	Resistor 1206 Surface Mount 0.25W 1% 100K
R193	1A410	Resistor 1206 Surface Mount 0.25W 1% 100K
R194	1A410	Resistor 1206 Surface Mount 0.25W 1% 100K
R195	1A210	Resistor 1206 Surface Mount 0.25W 1% 1K0
R196	1A210	Resistor 1206 Surface Mount 0.25W 1% 1K0
R197	1A410	Resistor 1206 Surface Mount 0.25W 1% 100K
R198	1A410	Resistor 1206 Surface Mount 0.25W 1% 100K
R199	1A410	Resistor 1206 Surface Mount 0.25W 1% 100K
R200	1A822	Resistor 1206 Surface Mount 0.25W 1% 2R2
R201	1A822	Resistor 1206 Surface Mount 0.25W 1% 2R2
R202	1A822	Resistor 1206 Surface Mount 0.25W 1% 2R2
R203	1A247	Resistor 1206 Surface Mount 0.25W 1% 4K7
R204	1A310	Resistor 1206 Surface Mount 0.25W 1% 10K
R300	1A133	Resistor 1206 Surface Mount 0.25W 1% 330R
R302	1A212	Resistor 1206 Surface Mount 0.25W 1% 1K2
R303	1A147	Resistor 1206 Surface Mount 0.25W 1% 470R
R304	1A133	Resistor 1206 Surface Mount 0.25W 1% 330R
R307	1A122	Resistor 1206 Surface Mount 0.25W 1% 220R
RLY100	A216	Relay 2P2T 5V SM
SK2	8D225	Phono Skt 4-WAY Gold
SK3	8D225	Phono Skt 4-WAY Gold
SK4	8D225	Phono Skt 4-WAY Gold
SK5	8D225	Phono Skt 4-WAY Gold
SK6	8D226	Phono Skt 2-WAY Vert Gold
SK100	8K8022B	Con 1.00MM Vertical FFC 22WAY 52806 Series
SK101	8K8330	Con 1.00MM Vertical SM FFC 30WAY
SK102	8K2404	Con CT Series Vertical 4WAY
SK103	8K2408	Con CT Series Vertical 8WAY
SK300	8K2304	Con Minifit HCS 4WAY
SK301	8K6604	Con KK Series 0.1in Vertical Friction Lock Hdr 4WAY
Z100	5S408DY	IC Analogue Mux DG408DY SO-16 Package
Z101	5S408DY	IC Analogue Mux DG408DY SO-16 Package
Z102	5S408DY	IC Analogue Mux DG408DY SO-16 Package
Z103	5S408DY	IC Analogue Mux DG408DY SO-16 Package
Z104	5S408DY	IC Analogue Mux DG408DY SO-16 Package
Z105	5S408DY	IC Analogue Mux DG408DY SO-16 Package
Z106	5S413DY	IC Quad Analogue Switch DG413DY SO-16 Package
Z107	5AVSDVC	IC Audio Dig Volume Control MAS9116ASBA-T SO-16W Package
Z108	5A1844	IC Quad Digital Pot 10K Lin SO-20
Z109	5B072D	Opamp TL072CD SO-8 Package
Z110	5B072D	Opamp TL072CD SO-8 Package
Z111	5B072D	Opamp TL072CD SO-8 Package
Z112	5B072D	Opamp TL072CD SO-8 Package
Z113	5B072D	Opamp TL072CD SO-8 Package
Z114	5B072D	Opamp TL072CD SO-8 Package
Z115	5B2134	Opamp OPA2134UA SO-8 Package
Z116	5B2134	Opamp OPA2134UA SO-8 Package
Z117	5B2134	Opamp OPA2134UA SO-8 Package
Z301	5D317T	IC Voltage Regulator ADJ LM317T TO-220 Package

C30 Preamplifier phono cct board L870AY issue 2.0

Designator	Part	Description
C1	2A410	CERD 100N 63V -20% +80% RA
C100	2N622	ELST 22U 63V
C101	2D210	PPRO 1N0 5% 63V RA
C102	2P710AS	ELEC 100U 25V SILMIC
C103	2P710AS	ELEC 100U 25V SILMIC
C104	2K410	PEST 100N 63V 10%
C105	2K410	PEST 100N 63V 10%
C106	2K410	PEST 100N 63V 10%
C107	2K410	PEST 100N 63V 10%
C108	2D147W	PPRO W 470P 63V 5% RA
C109	2D110W	PPRO W 100P 63V 5% RA
C110	2D247N	PPRO 4N7 63V 5% RA
C111	2D310	PPRO 10N 63V 1% AXIAL
C112	2D310	PPRO 10N 63V 1% AXIAL
C113	2K510	CAP MKS2 1U0 16V 10%
C115	2D213N	PPRO 1N3 63V 5% RA
C116	2D147W	PPRO W 470P 63V 5% RA
C117	2D147W	PPRO W 470P 63V 5% RA
C118	2U610	ELST NON POLAR 10UF 35V
C119	2D110N	PPRO 100P 63V 5% RA
C120	2D210	PPRO 1N0 5% 63V RA
C200	2N622	ELST 22U 63V
C201	2D210	PPRO 1N0 5% 63V RA
C202	2P710AS	ELEC 100U 25V SILMIC
C203	2P710AS	ELEC 100U 25V SILMIC
C204	2K410	PEST 100N 63V 10%
C205	2K410	PEST 100N 63V 10%
C206	2K410	PEST 100N 63V 10%
C207	2K410	PEST 100N 63V 10%
C208	2D147W	PPRO W 470P 63V 5% RA
C209	2D110W	PPRO W 100P 63V 5% RA
C210	2D247N	PPRO 4N7 63V 5% RA
C211	2D310	PPRO 10N 63V 1% AXIAL
C212	2D310	PPRO 10N 63V 1% AXIAL
C213	2K510	CAP MKS2 1U0 16V 10%
C215	2D213N	PPRO 1N3 63V 5% RA
C216	2D147W	PPRO W 470P 63V 5% RA
C217	2D147W	PPRO W 470P 63V 5% RA
C218	2U610	ELST NON POLAR 10UF 35V
C219	2D110N	PPRO 100P 63V 5% RA
C220	2D210	PPRO 1N0 5% 63V RA
D100	3A4148	SSDIODE 1N4148 75V
D101	3A4148	SSDIODE 1N4148 75V
D102	3A4148	SSDIODE 1N4148 75V
D200	3A4148	SSDIODE 1N4148 75V
D201	3A4148	SSDIODE 1N4148 75V
D202	3A4148	SSDIODE 1N4148 75V
IC100	5B071	IC FET OPAMP TL071
IC200	5B071	IC FET OPAMP TL071
PCB1	L870PB_2	PRINTED CIRCUIT BOARD
R100	1H133	RES MF W4 1% 330R
R101	1H110	RES MF W4 1% 100R
R102	1H110	RES MF W4 1% 100R
R104	1H110	RES MF W4 1% 100R
R105	1H110	RES MF W4 1% 100R
R106	1H110	RES MF W4 1% 100R
R108	1H347	RES MF W4 1% 47K
R109	1H312	RES MF W4 1% 12K
R110	1H312	RES MF W4 1% 12K
R111	1H356	RES MF W4 1% 56K
R112	1H410	RES MF W4 1% 100K
R113	1H410	RES MF W4 1% 100K
R114	1H410	RES MF W4 1% 100K
R115	1H315	RES MF W4 1% 15K
R116	1H522	RES MF W4 1% 2M2

C30 Preamplifier phono cct board L870AY issue 2.0

Designator	Part	Description
R117	1H522	RES MF W4 1% 2M2
R118	1H022	RES MF W4 1% 22R
R119	1H022	RES MF W4 1% 22R
R120	1H022	RES MF W4 1% 22R
R121	1H022	RES MF W4 1% 22R
R122	1H339	RES MF W4 1% 39K
R123	1H010	RES MF W4 1% 10R
R124	1H256	RES MF W4 1% 5K6
R200	1H133	RES MF W4 1% 330R
R201	1H110	RES MF W4 1% 100R
R202	1H110	RES MF W4 1% 100R
R204	1H110	RES MF W4 1% 100R
R205	1H110	RES MF W4 1% 100R
R206	1H110	RES MF W4 1% 100R
R208	1H347	RES MF W4 1% 47K
R209	1H312	RES MF W4 1% 12K
R210	1H312	RES MF W4 1% 12K
R211	1H356	RES MF W4 1% 56K
R212	1H410	RES MF W4 1% 100K
R213	1H410	RES MF W4 1% 100K
R214	1H410	RES MF W4 1% 100K
R215	1H315	RES MF W4 1% 15K
R216	1H522	RES MF W4 1% 2M2
R217	1H522	RES MF W4 1% 2M2
R218	1H022	RES MF W4 1% 22R
R219	1H022	RES MF W4 1% 22R
R220	1H022	RES MF W4 1% 22R
R221	1H022	RES MF W4 1% 22R
R222	1H339	RES MF W4 1% 39K
R223	1H010	RES MF W4 1% 10R
R224	1H256	RES MF W4 1% 5K6
SK1	8D230	PHONO SKT 2-WAY HOR EMC GOLD
SK2	8K2408	8-WAY AMP CT CONN
SW100	A1013	SW PUSH 4PCO
TR100	4A556	TRANS LF SS P BC556B
TR101	4A556	TRANS LF SS P BC556B
TR102	4A556	TRANS LF SS P BC556B
TR103	4A556	TRANS LF SS P BC556B
TR104	4A556	TRANS LF SS P BC556B
TR105	4A556	TRANS LF SS P BC556B
TR106	4A1085	TRANS LF SS P 2SA1085
TR107	4A1085	TRANS LF SS P 2SA1085
TR108	4A546	TRANS LF SS N BC546B
TR109	4A546	TRANS LF SS N BC546B
TR110	4A546	TRANS LF SS N BC546B
TR111	4A546	TRANS LF SS N BC546B
TR112	4A546	TRANS LF SS N BC546B
TR113	4A546	TRANS LF SS N BC546B
TR114	4A546	TRANS LF SS N BC546B
TR200	4A556	TRANS LF SS P BC556B
TR201	4A556	TRANS LF SS P BC556B
TR202	4A556	TRANS LF SS P BC556B
TR203	4A556	TRANS LF SS P BC556B
TR204	4A556	TRANS LF SS P BC556B
TR205	4A556	TRANS LF SS P BC556B
TR206	4A1085	TRANS LF SS P 2SA1085
TR207	4A1085	TRANS LF SS P 2SA1085
TR208	4A546	TRANS LF SS N BC546B
TR209	4A546	TRANS LF SS N BC546B
TR210	4A546	TRANS LF SS N BC546B
TR211	4A546	TRANS LF SS N BC546B
TR212	4A546	TRANS LF SS N BC546B
TR213	4A546	TRANS LF SS N BC546B
TR214	4A546	TRANS LF SS N BC546B

ARCAM

All parts can be ordered via spares@arcam.co.uk

Pembroke Ave, Waterbeach, Cambridge, CB5 9PB, ENGLAND
TEL: +44(0) 1223 203 203 FAX: +44(0) 1223 863 384