

# ARCAM

## ENGINEERING NOTICE

### T32 Conversion to Gyrosignal 1128B DAB module from Radioscape RS223

The Radioscape RS223 DAB module, used in the T32, has become obsolete. The Gyrosignal 1128B module will replace the Radioscape RS223 in future production. This document details how to convert a T32 configured for the Radioscape RS223 module into the Gyrosignal 1128B variant.

#### **PARTS REQUIRED:**

- TGP3554            Arcam carrier PCB for Gyro 1128B module
- B032              Gyrosignal 1128B DAB module
- L3003SW          Arcam T32 software update version 3.04

## T32 Conversion to Gyrosignal 1128B DAB module from Radioscape RS223

1. U601 PIN 28 must be lifted (make open circuit, internal pullup)

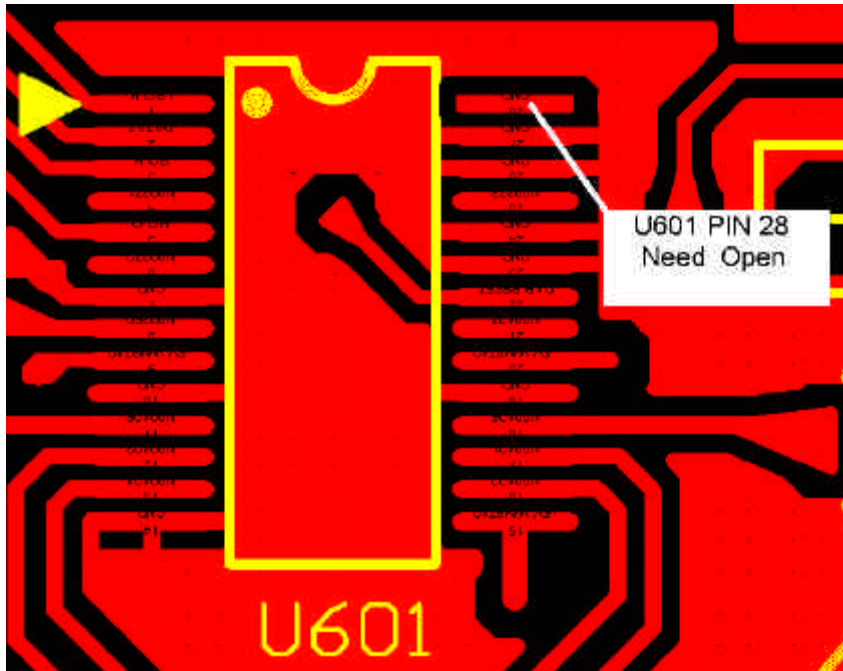

2. Insert Gyrosignal 1128B DAB module and carrier PCB. Fit antenna cable to rear panel, coiling excess cable.

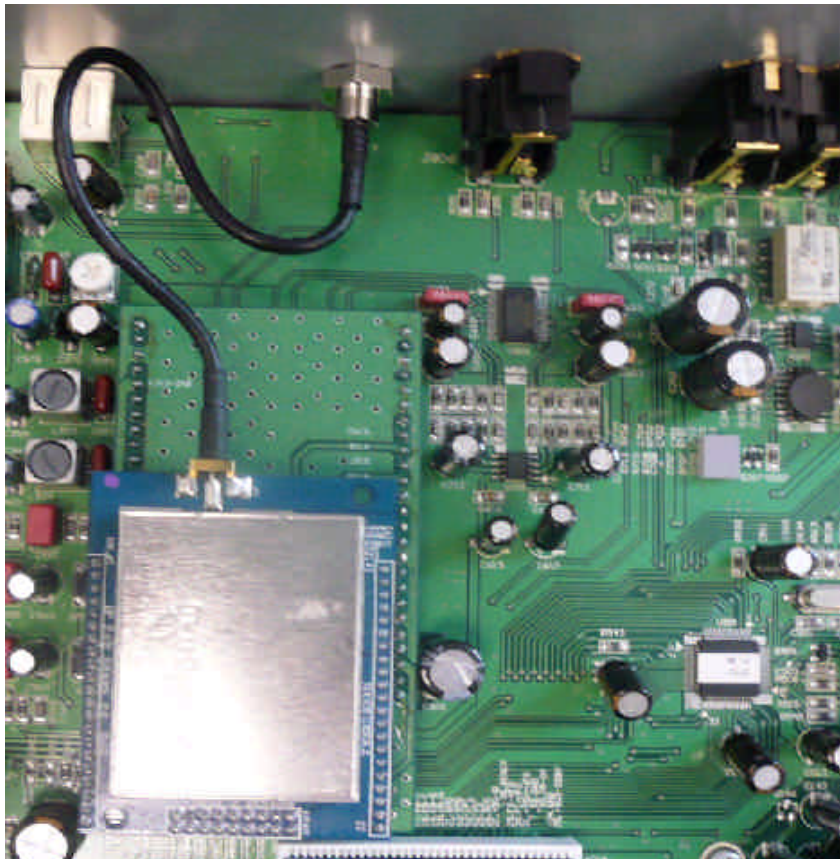

3. Update software to latest version, V3.04

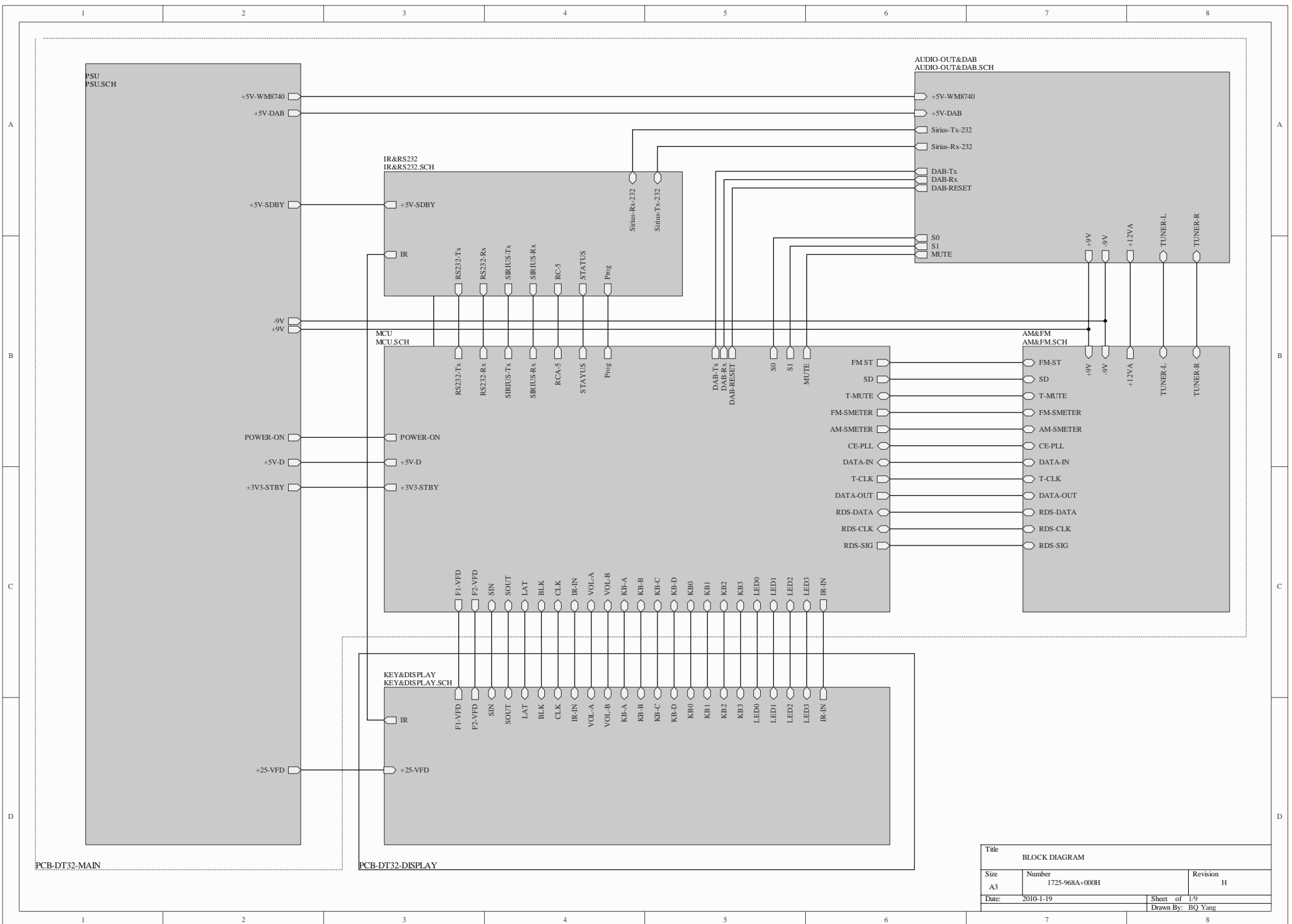

PCB-DT32-MAIN

PCB-DT32-DISPLAY

Title		
BLOCK DIAGRAM		
Size	Number	Revision
A3	1725-968A+000H	H
Date:	2010-1-19	Sheet of 1/9
		Drawn By: BQ Yang

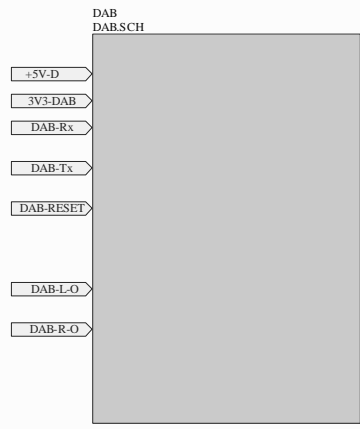
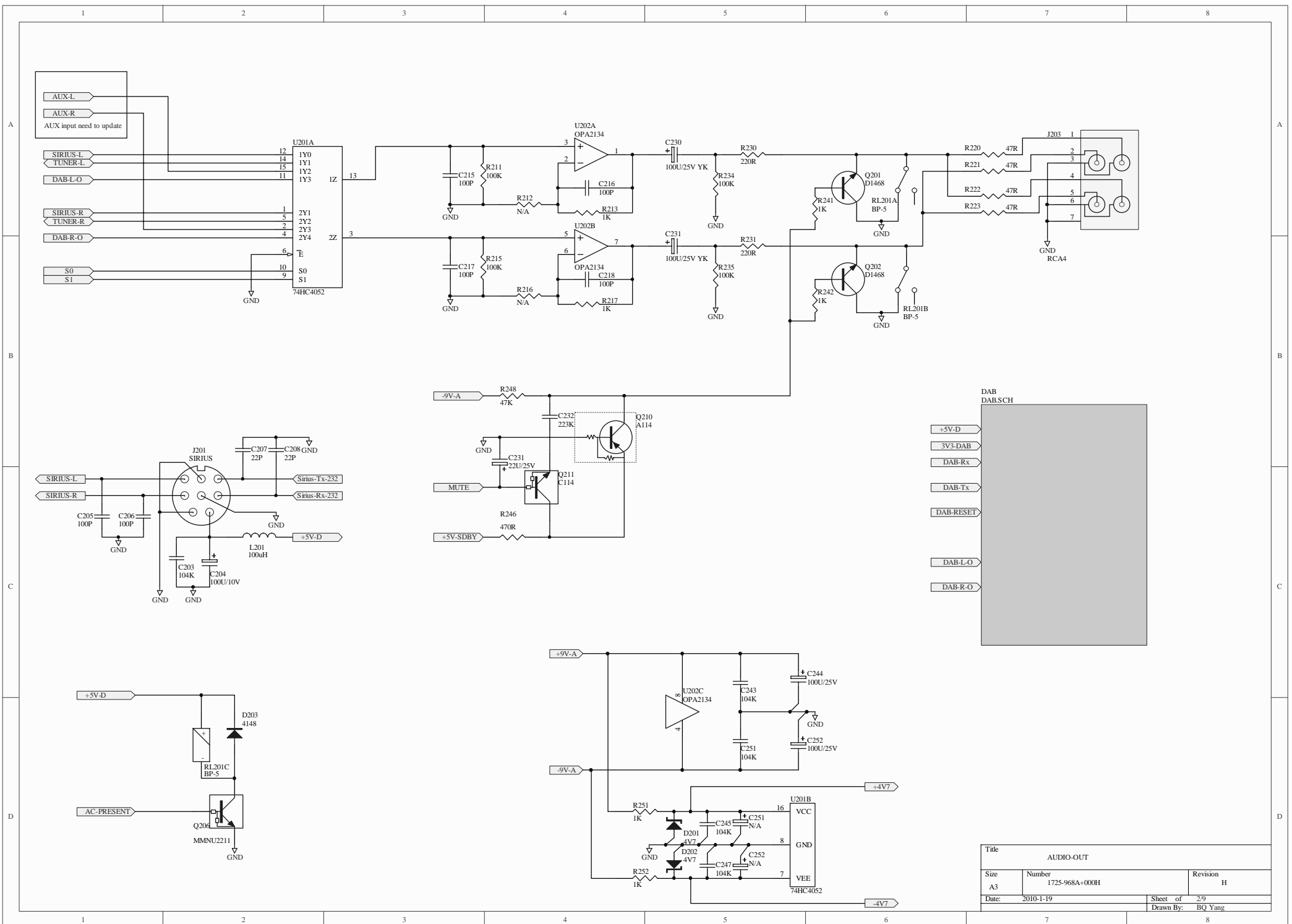

Title		AUDIO-OUT	
Size	Number	Revision	
A3	1725-968A+000H	H	
Date:	2010-1-19	Sheet of	29
		Drawn By:	BQ Yang

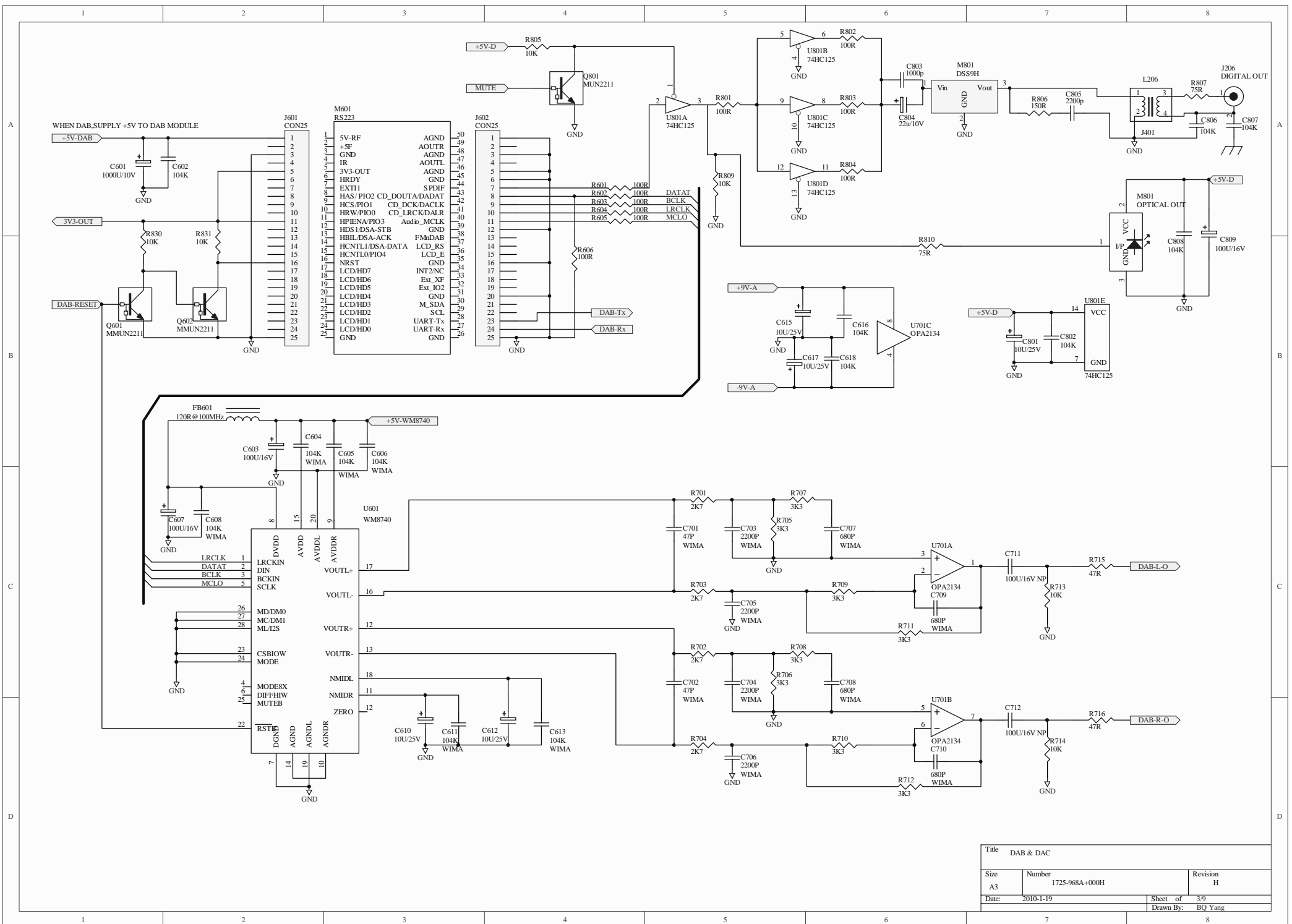

Title			DAB & DAC		
Size	Number	Revision			
A3	1725-968A+000H	H			
Date:	2010-1-19	Sheet of	39		
		Drawn By:	BQ Yang		

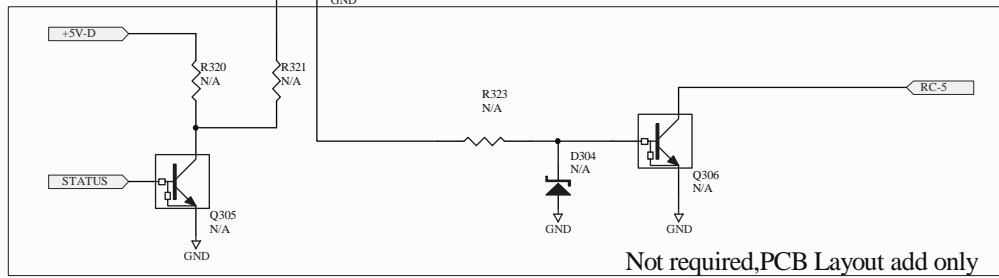
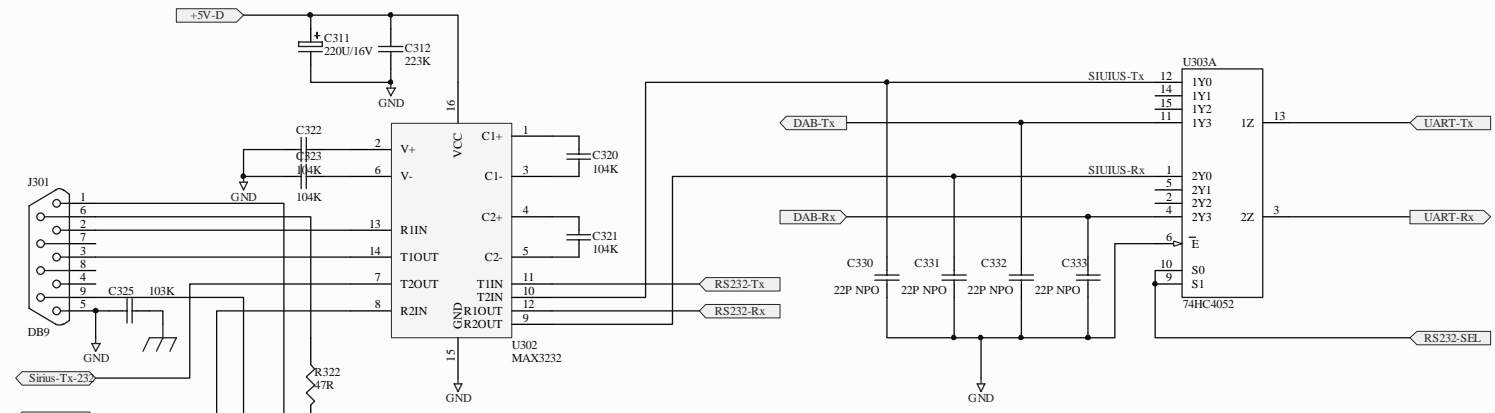
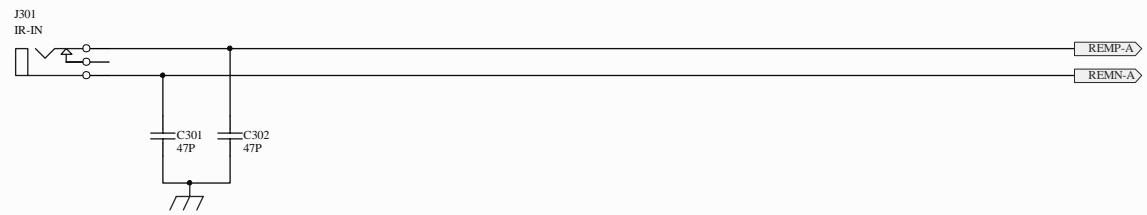

Not required,PCB Layout add only

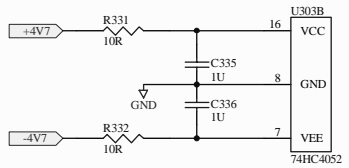

Title			
IR & RS232			
Size	Number	Revision	
A3	1725-968A+000H	H	
Date:	2010-1-19	Sheet of	49
		Drawn By:	BQ Yang

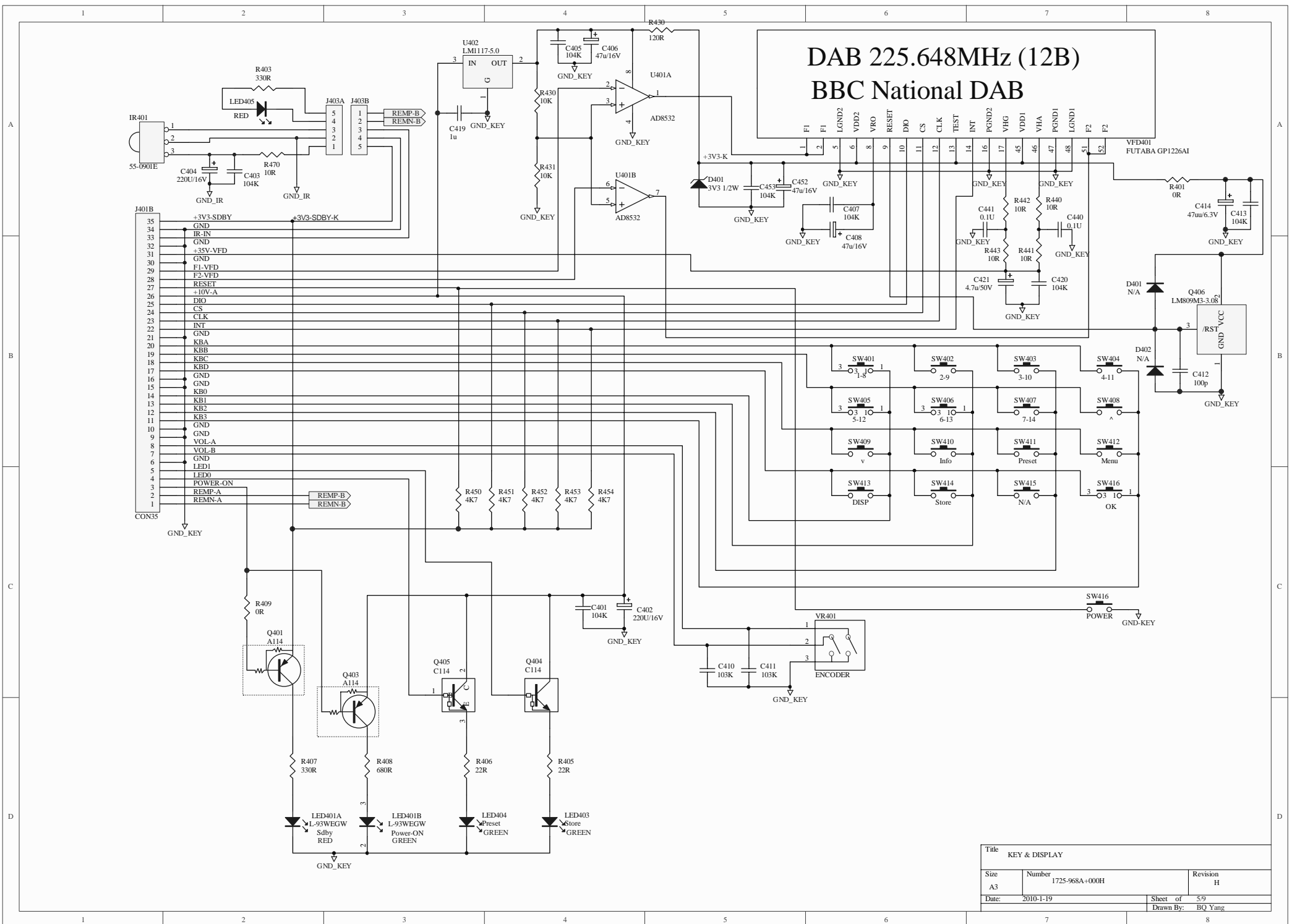

Title		
KEY & DISPLAY		
Size	Number	Revision
A3	1725-968A+000H	H
Date:	2010-1-19	Sheet of 59
		Drawn By: BQ Yang

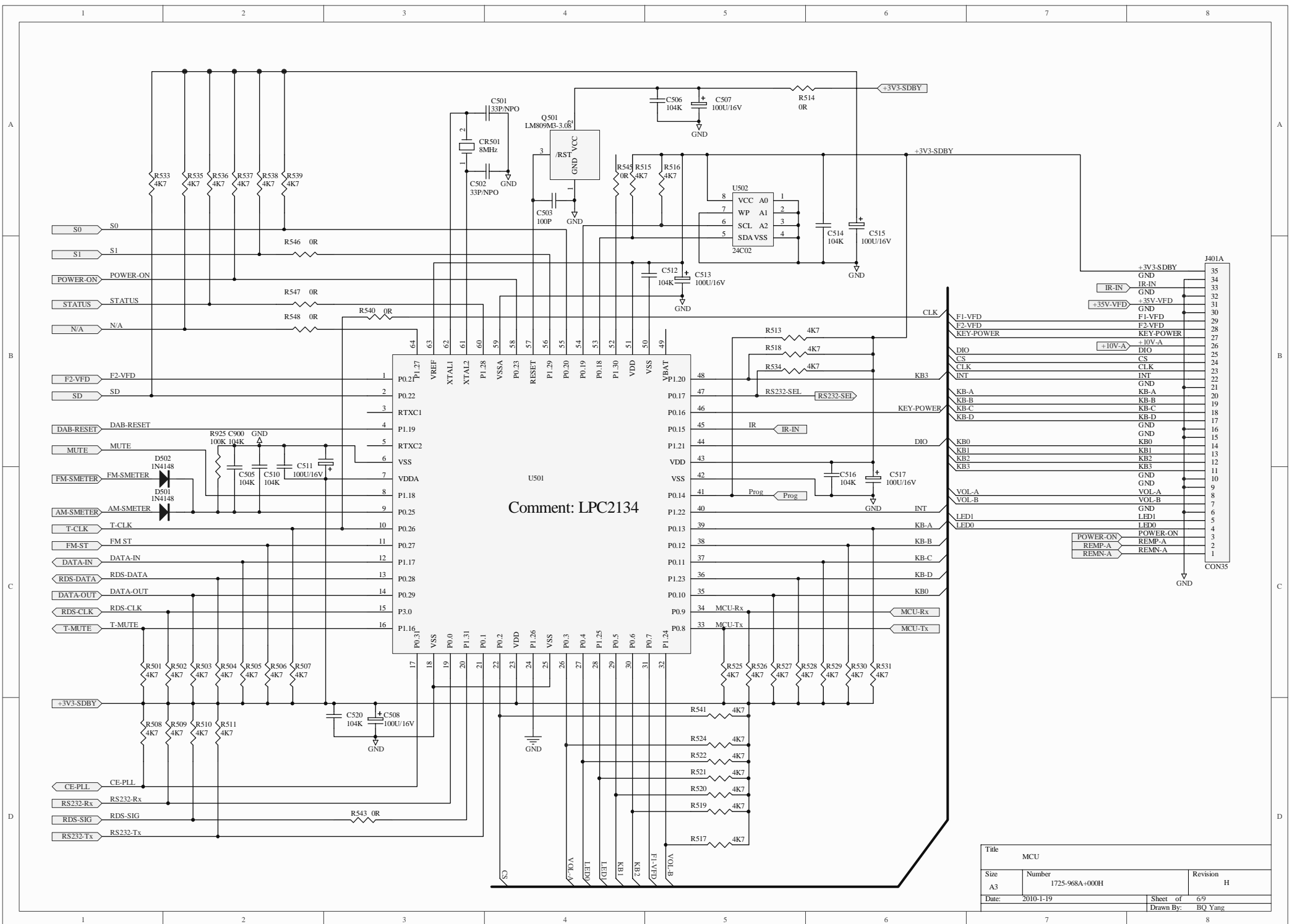

Comment: LPC2134

Title			MCU		
Size	Number			Revision	H
A3	1725-968A+000H				
Date:	2010-1-19	Sheet of	69	Drawn By:	BQ Yang



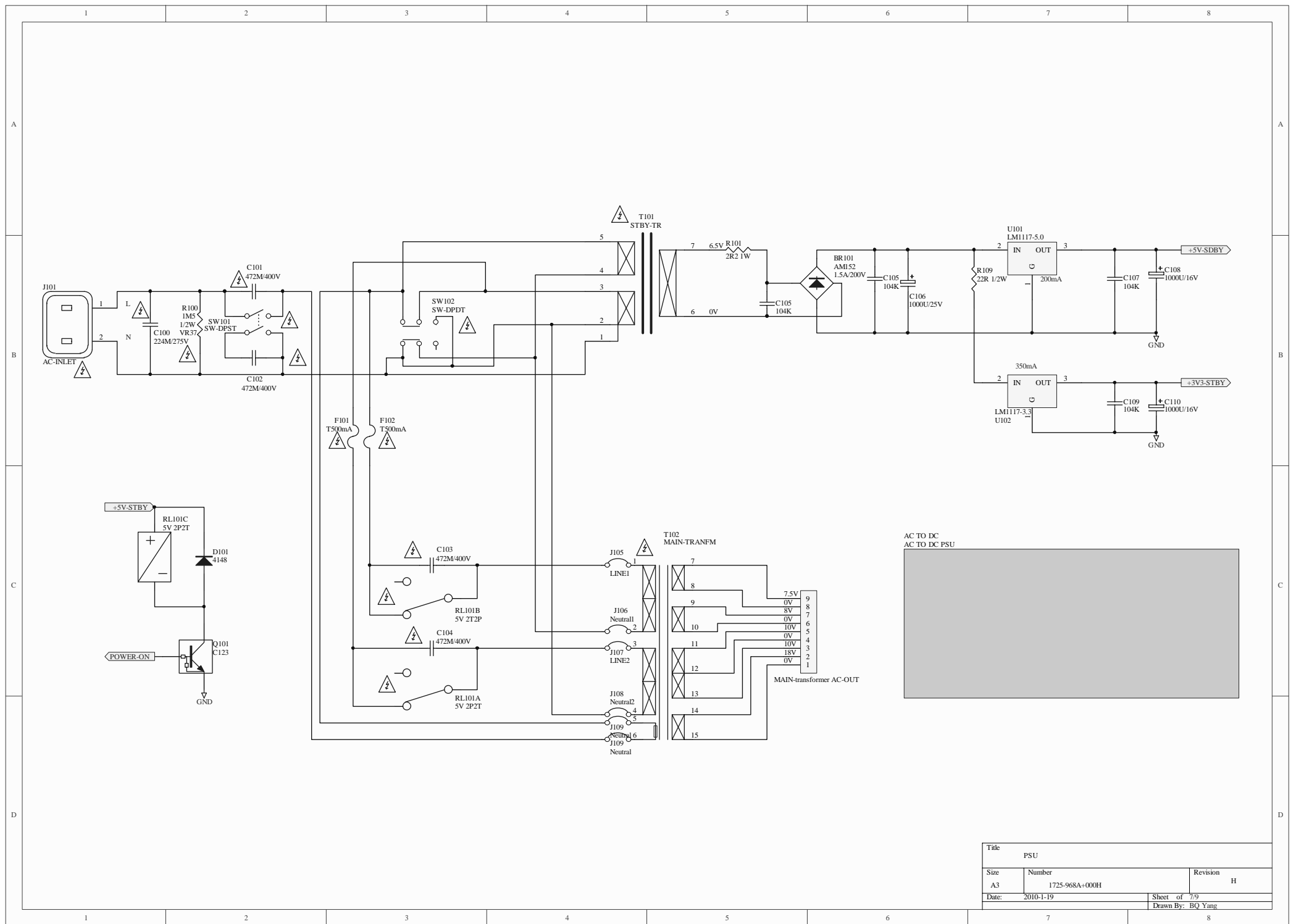

Title		
PSU		
Size	Number	Revision
A3	1725-968A+000H	H
Date:	2010-1-19	Sheet of 7/9
		Drawn By: BQ Yang

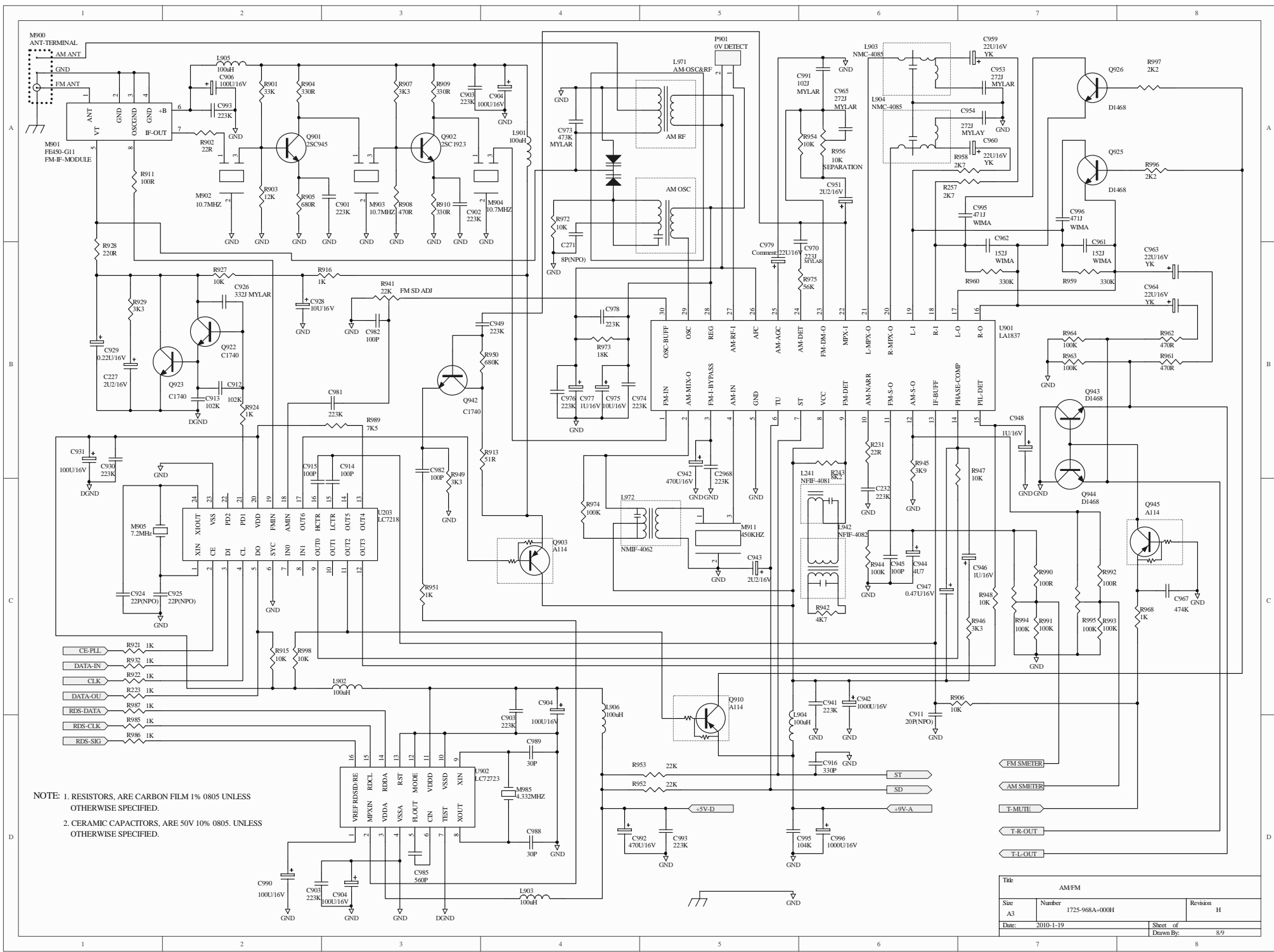

NOTE: 1. RESISTORS, ARE CARBON FILM 1% 0805 UNLESS OTHERWISE SPECIFIED.  
 2. CERAMIC CAPACITORS, ARE 50V 10% 0805, UNLESS OTHERWISE SPECIFIED.

Title: AM/FM		
Size: A3	Number: 1725-968A-000H	Revision: H
Date: 2010-1-19	Sheet of: 8/9	
Drawn By:		

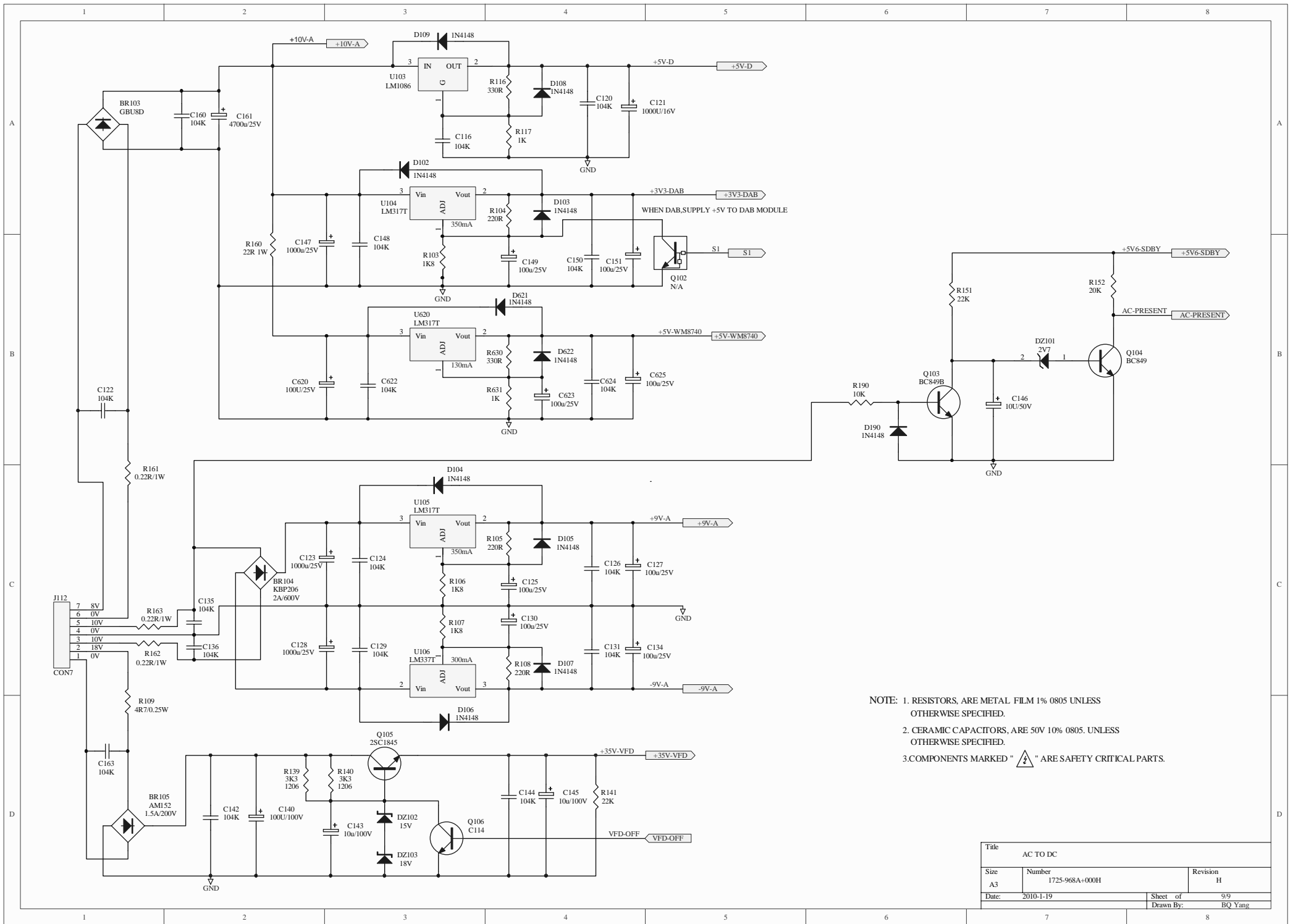

NOTE: 1. RESISTORS, ARE METAL FILM 1% 0805 UNLESS OTHERWISE SPECIFIED.  
 2. CERAMIC CAPACITORS, ARE 50V 10% 0805, UNLESS OTHERWISE SPECIFIED.  
 3. COMPONENTS MARKED "▲" ARE SAFETY CRITICAL PARTS.

Title		
AC TO DC		
Size	Number	Revision
A3	1725-968A-000H	H
Date:	2010-1-19	Sheet of 99
	Drawn By:	BQ Yang

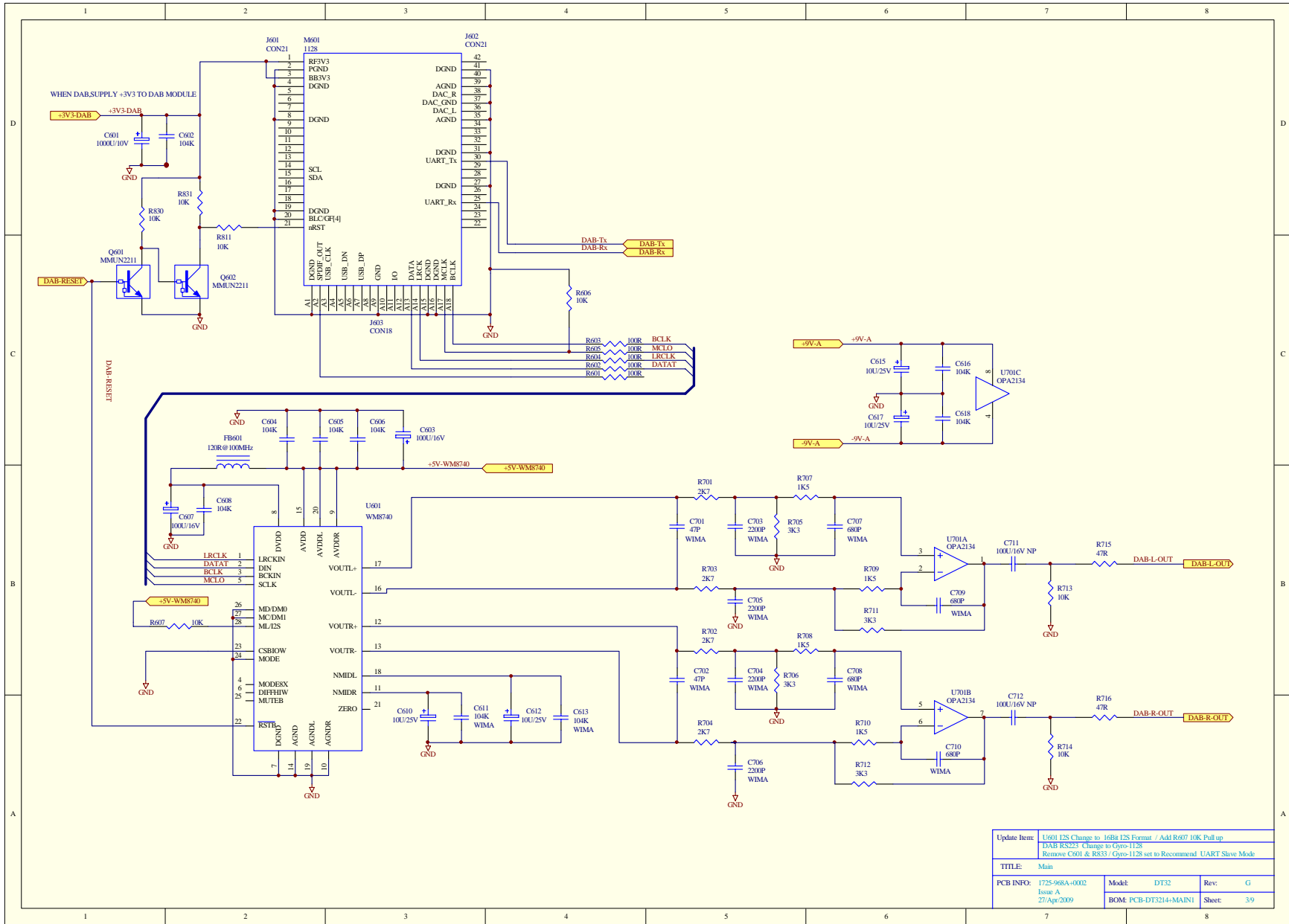

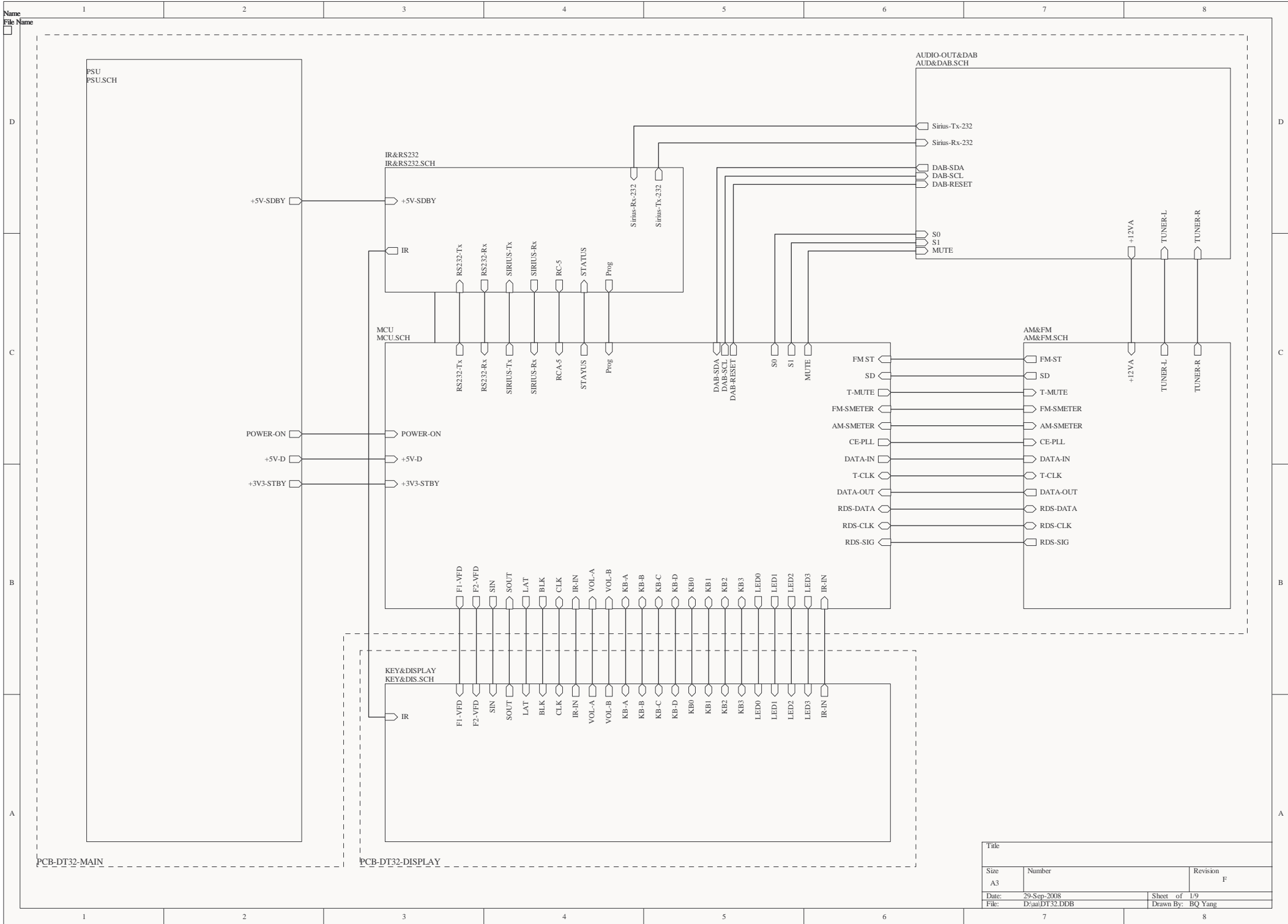

PCB-DT32-MAIN

PCB-DT32-DISPLAY

Title		
Size A3	Number	Revision F
Date: 29-Sep-2008	Sheet of 1/9	Drawn By: BQ Yang
File: D:\aa\DT32.DDB		

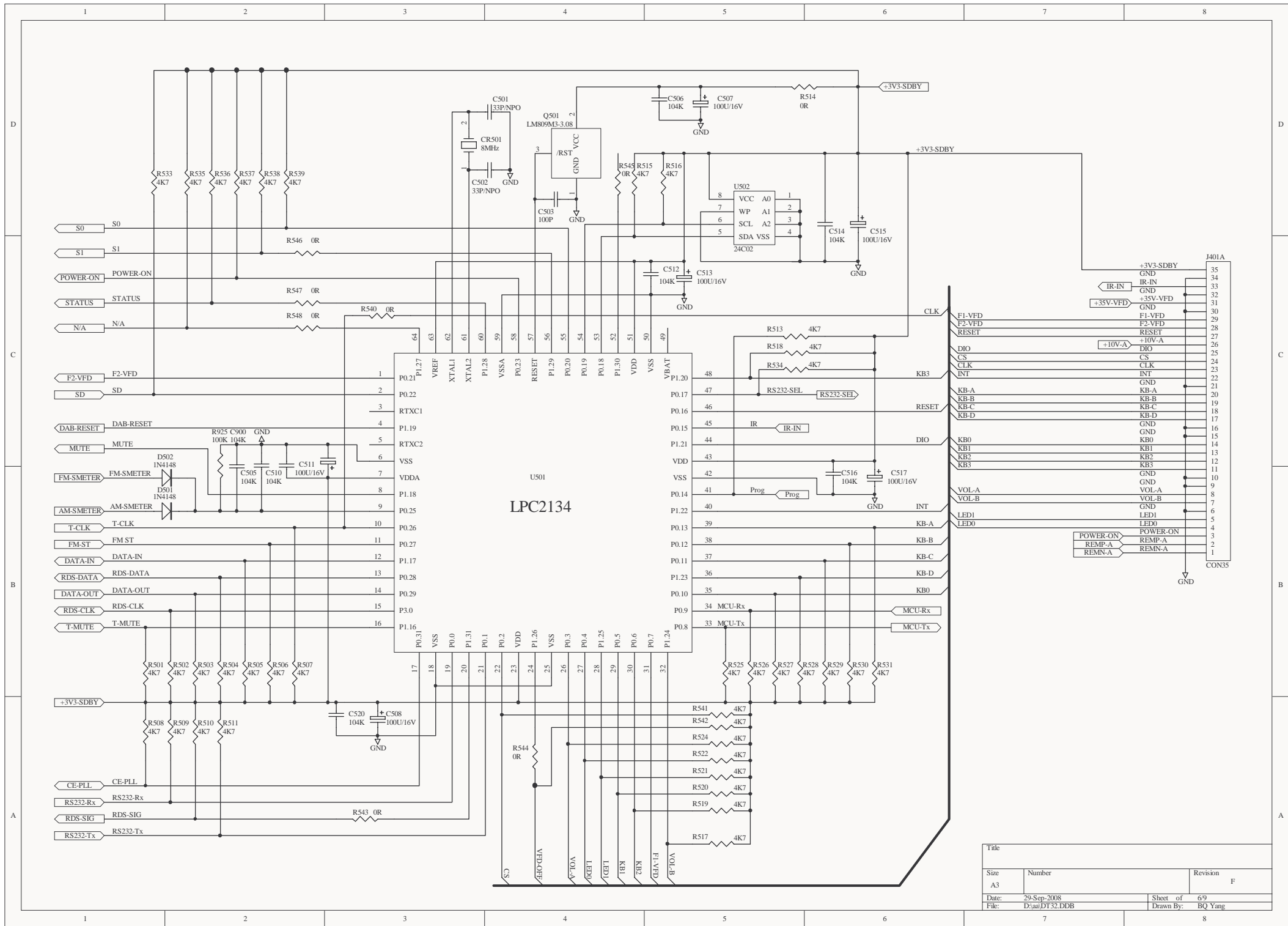

LPC2134

Title		
Size	Number	Revision
A3		F
Date:	29-Sep-2008	Sheet of 6/9
File:	D:\aaa\DT32.DDB	Drawn By: BQ Yang

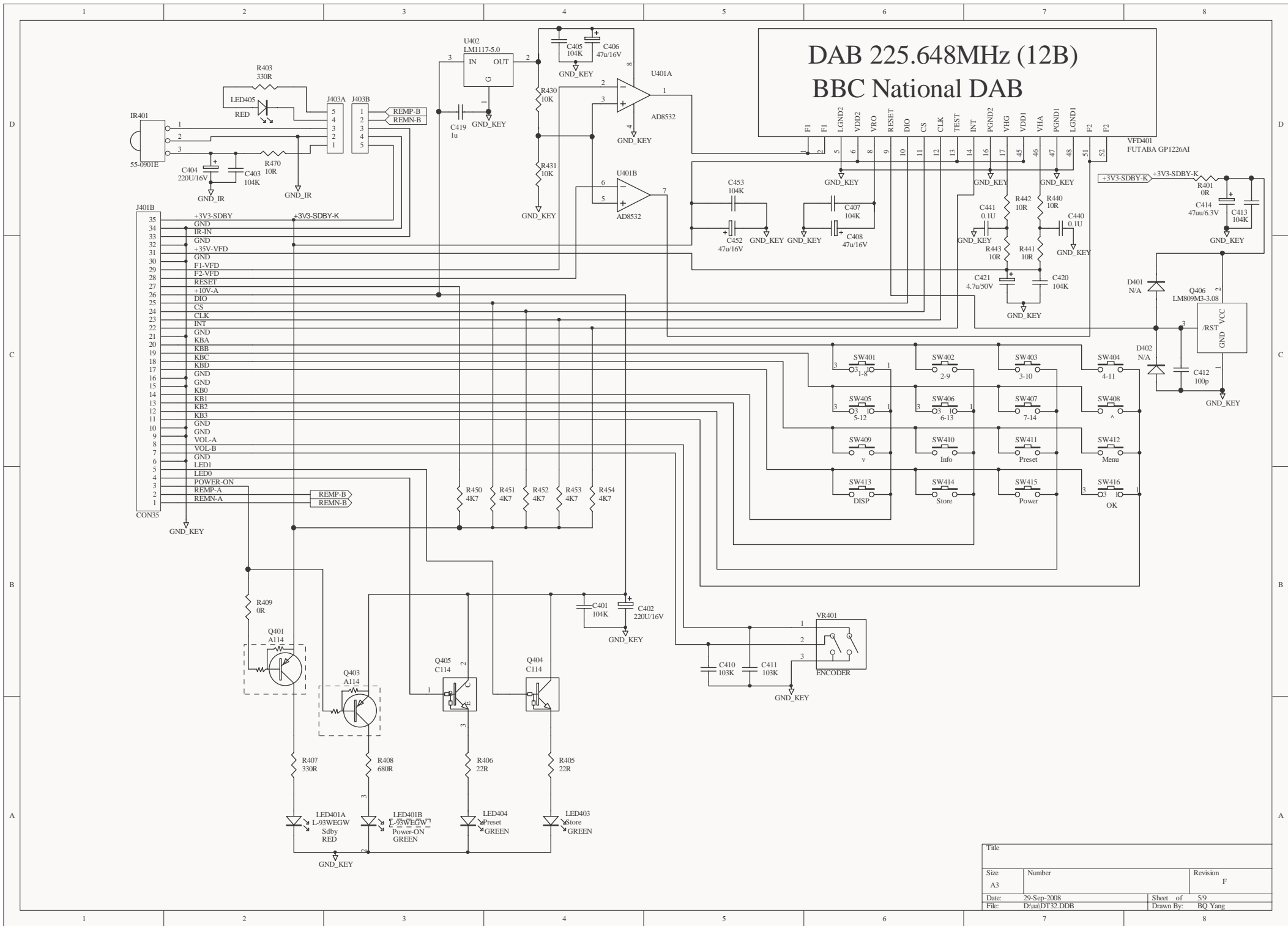

# DAB 225.648MHz (12B) BBC National DAB

Title		
Size A3	Number	Revision F
Date: 29-Sep-2008	Sheet of 5/9	Drawn By: BQ Yang
File: D:\aa\DT32.DDB		

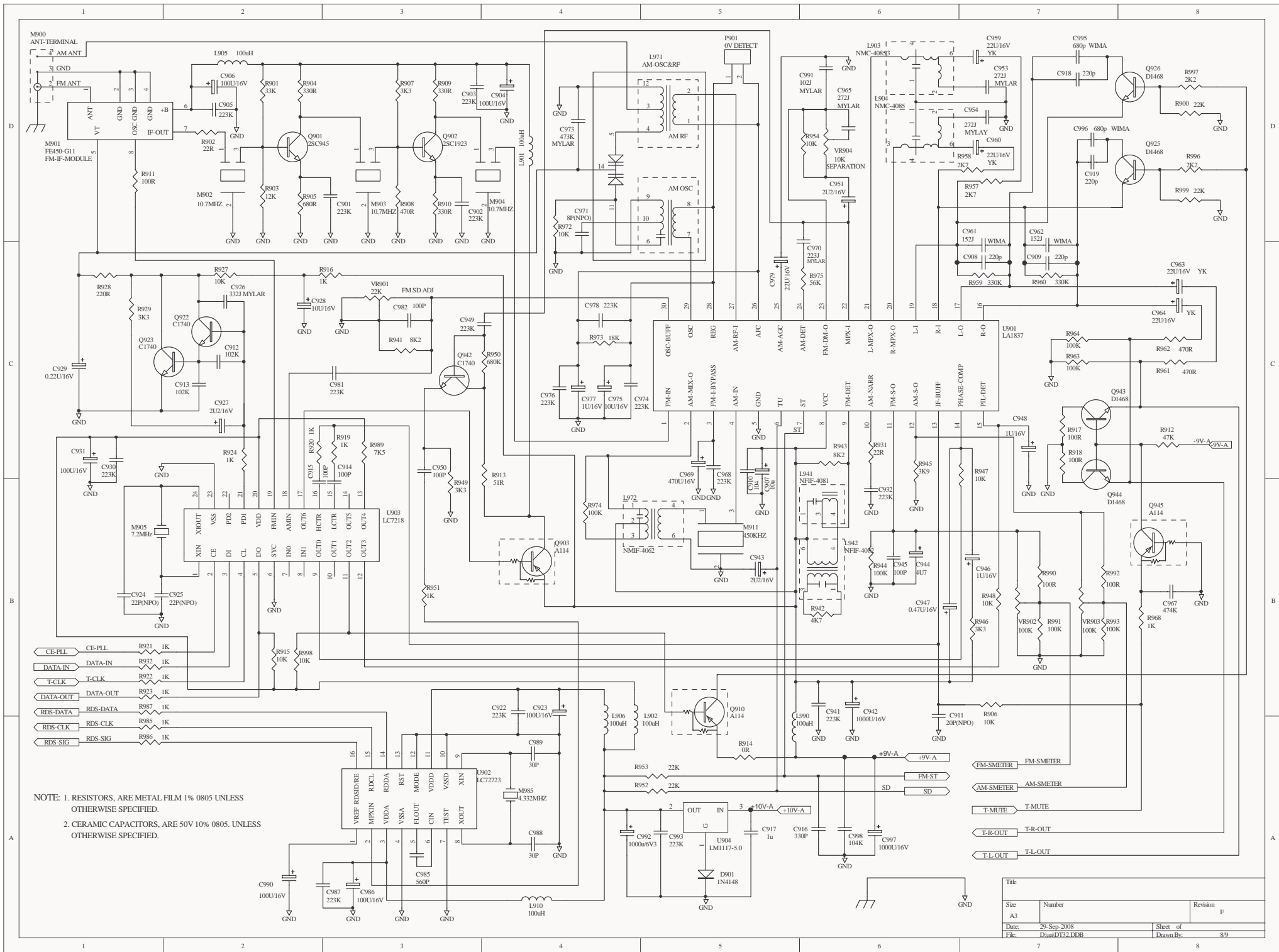



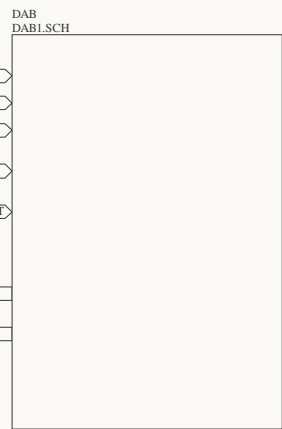
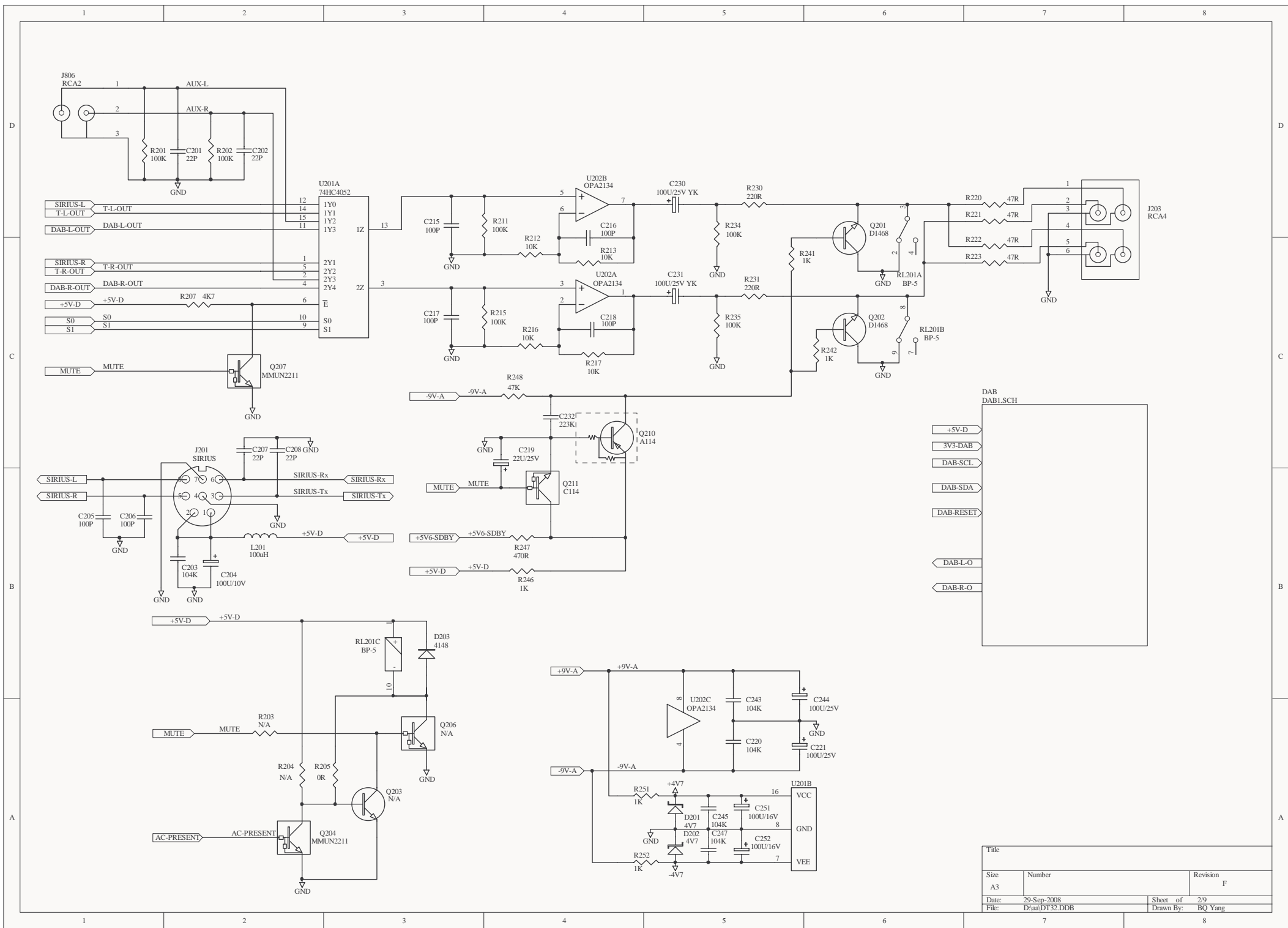

Title		
Size A3	Number	Revision F
Date: 29-Sep-2008	Sheet of 2/9	Drawn By: BQ Yang
File: D:\aa\DT32.DDB		

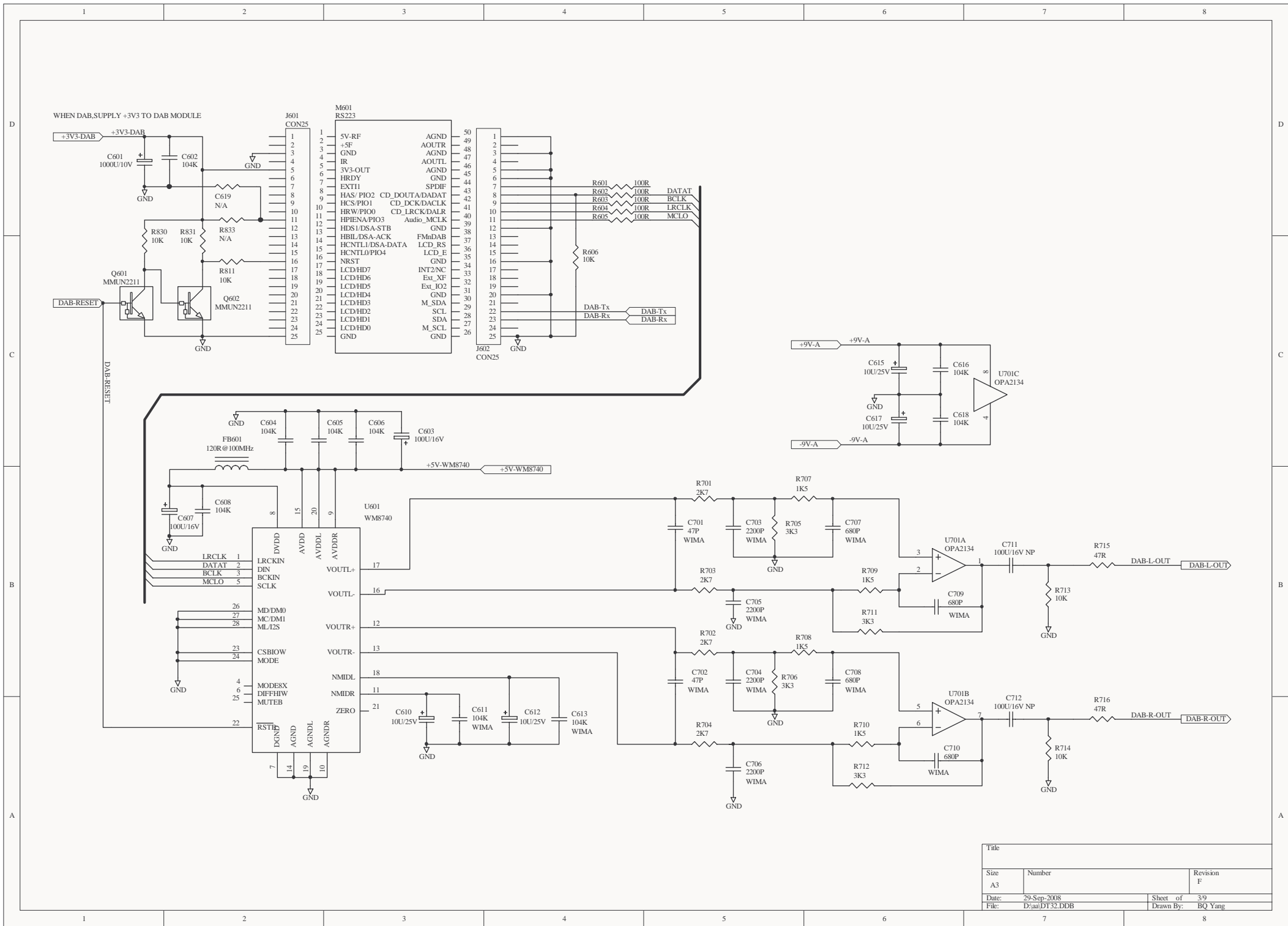

Title		
Size	Number	Revision
A3		F
Date:	29-Sep-2008	Sheet of 3/9
File:	D:\an\DT32.DDB	Drawn By: BQ Yang

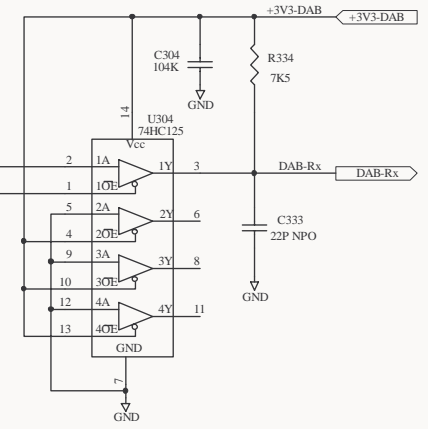
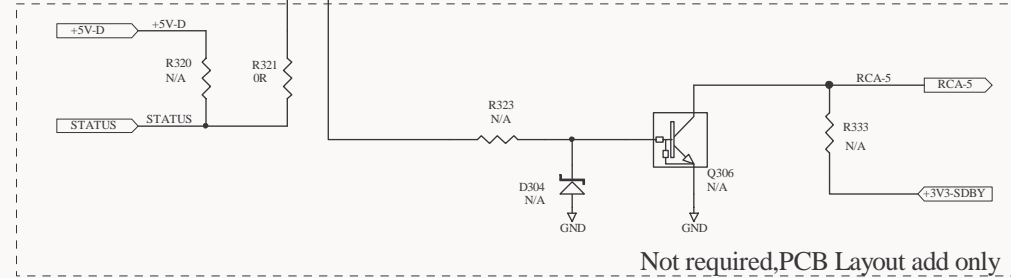
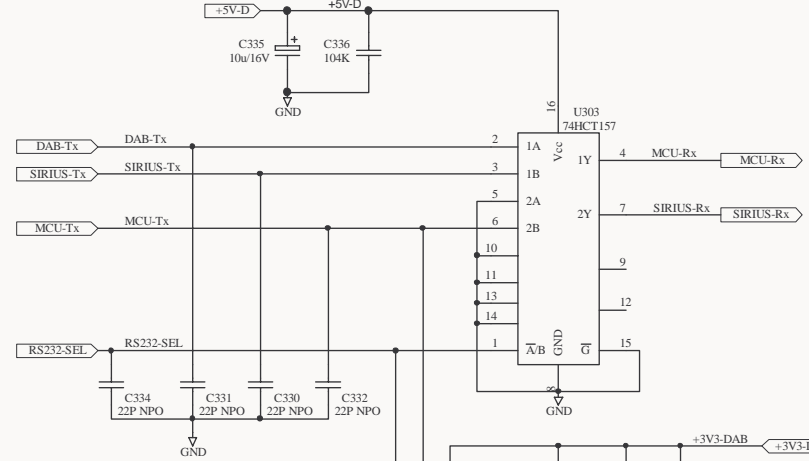
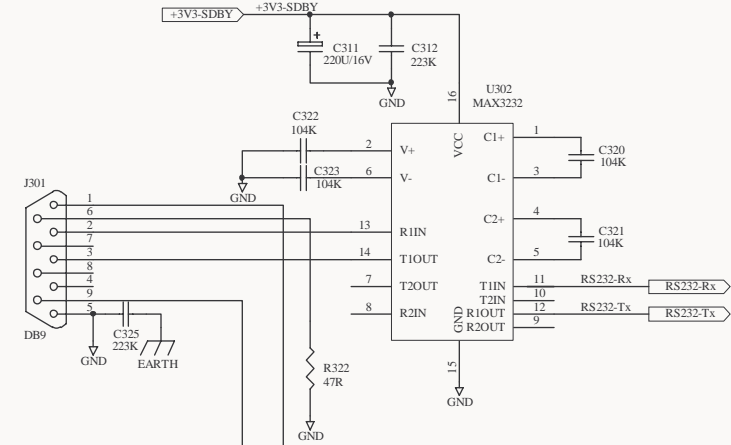

Title		
Size A3	Number	Revision F
Date: 29-Sep-2008	Sheet of 4/9	Drawn By: BQ Yang
File: D:\aa\DT32.DDB		

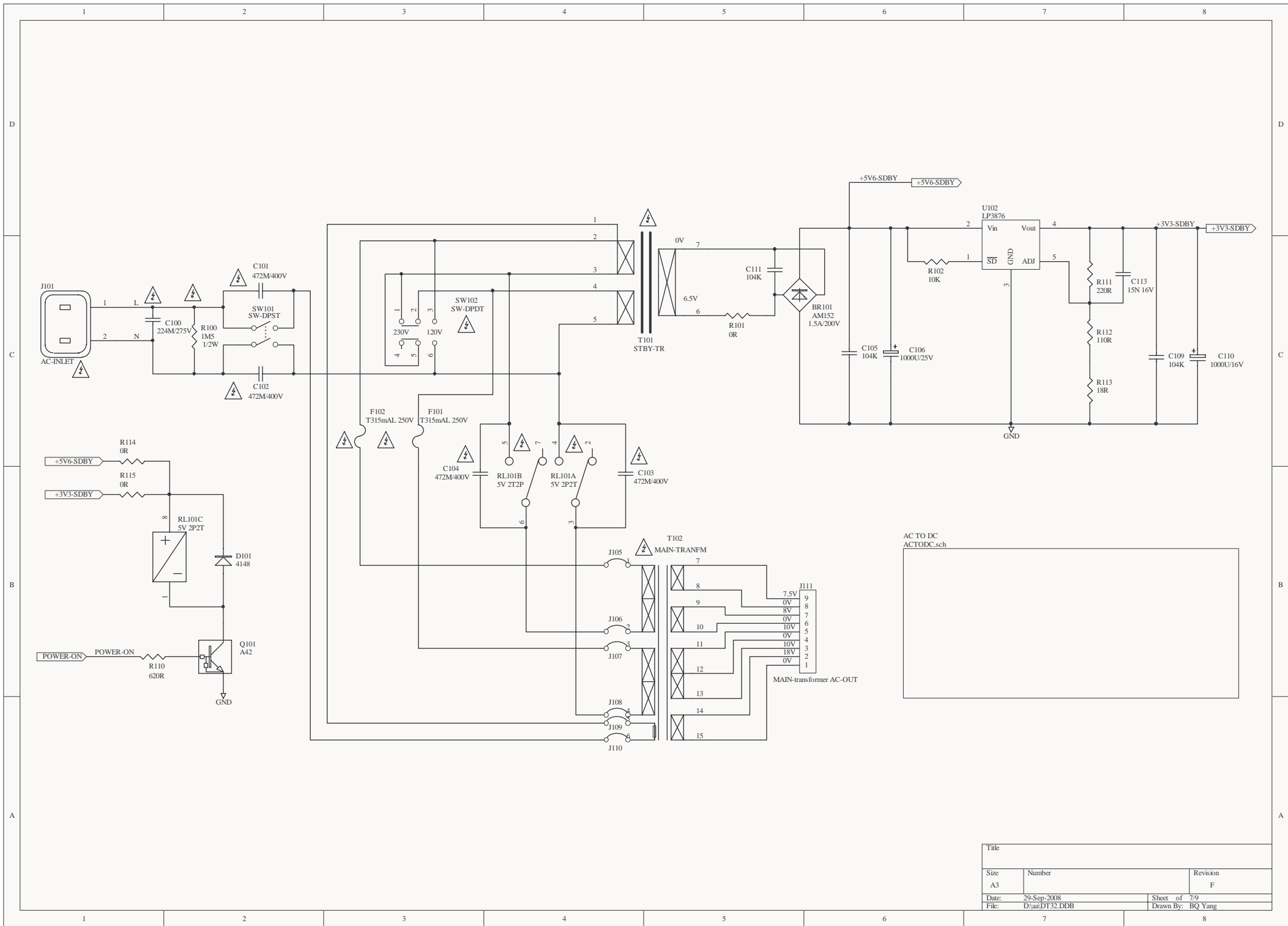

Title		
Size A3	Number	Revision F
Date: 29-Sep-2008	Sheet of 7/9	Drawn By: BQ Yang
File: D:\aa\DT32.DDB		



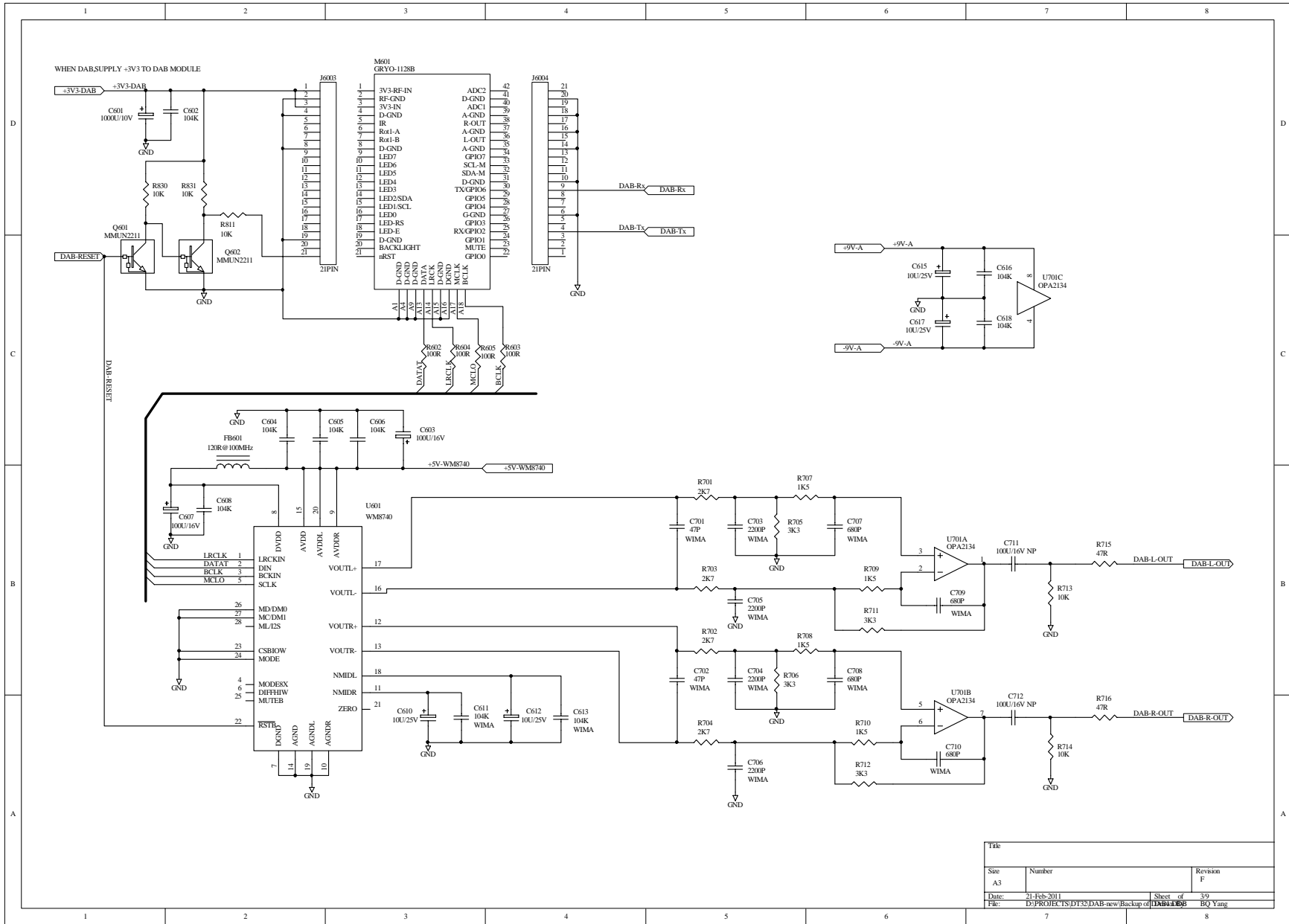

Title		
Size	Number	Revision
A3		F
Date:	21-Feb-2011	Sheet of 3/9
File:	D:\PROJECTS\DT32\DAB-new\Backup of DAB1.4\BQ Yang	