

AUDIO RESEARCH CORPORATION
 BIRMINGHAM, AL 35242-0101

CD1 MAIN
 Page 1 of 3
 3-18-84

PROPRIETARY NOTICE: THIS DRAWING CONTAINS PATENTED AND PATENT PENDING INFORMATION. ANY REPRODUCTION OR TRANSMISSION OF THIS DRAWING OR ANY PART THEREOF WITHOUT THE WRITTEN PERMISSION OF AUDIO RESEARCH CORPORATION IS PROHIBITED.

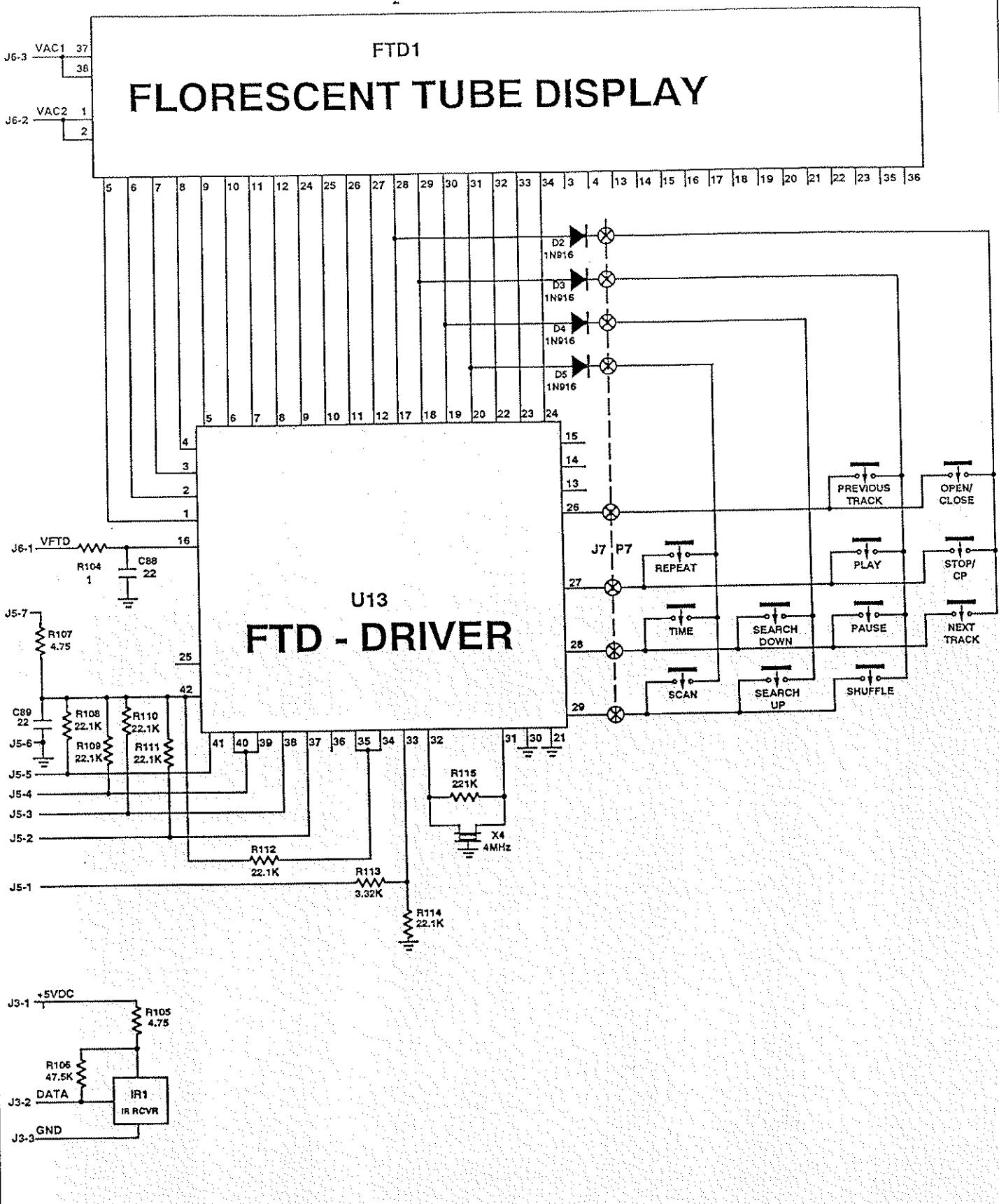

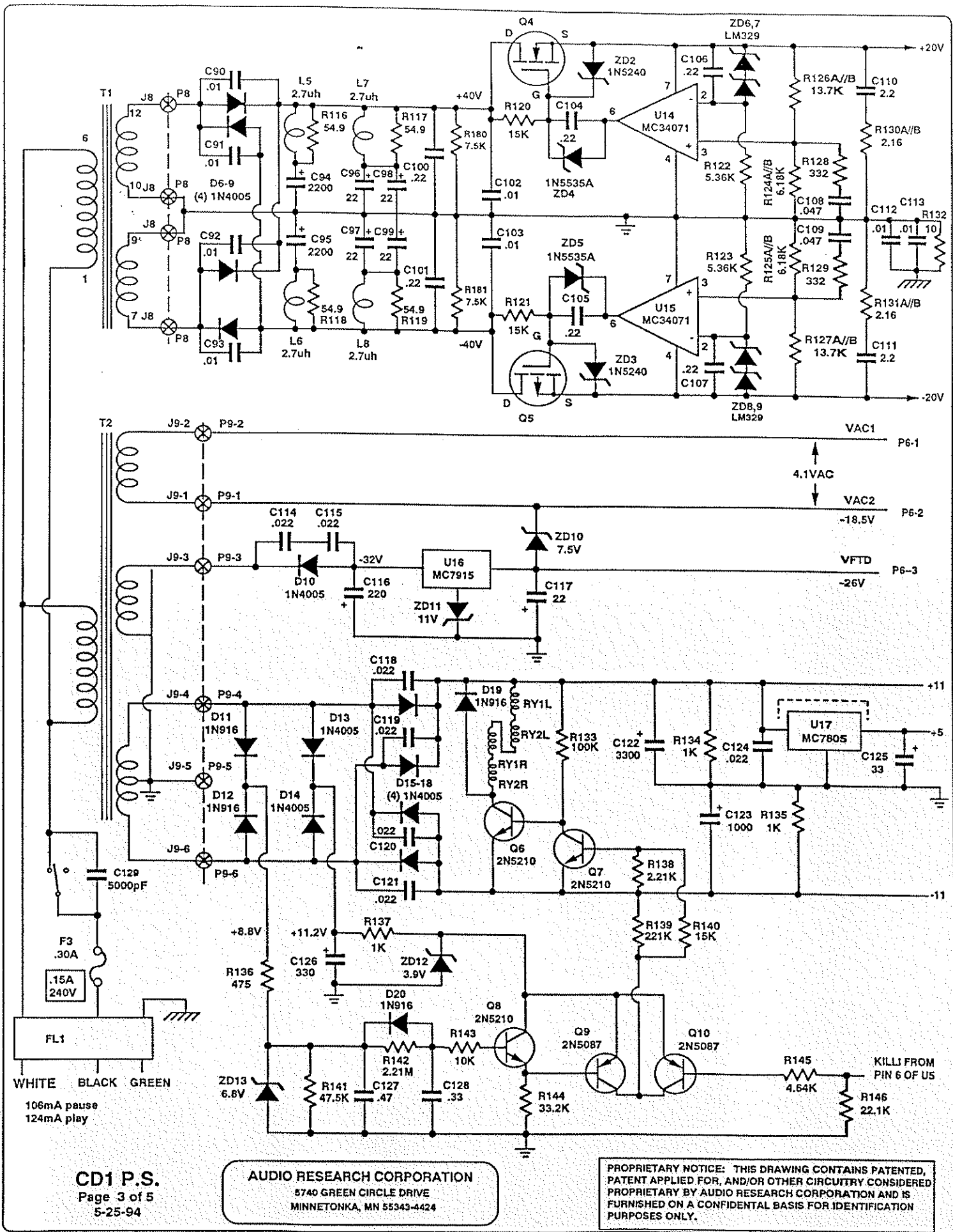

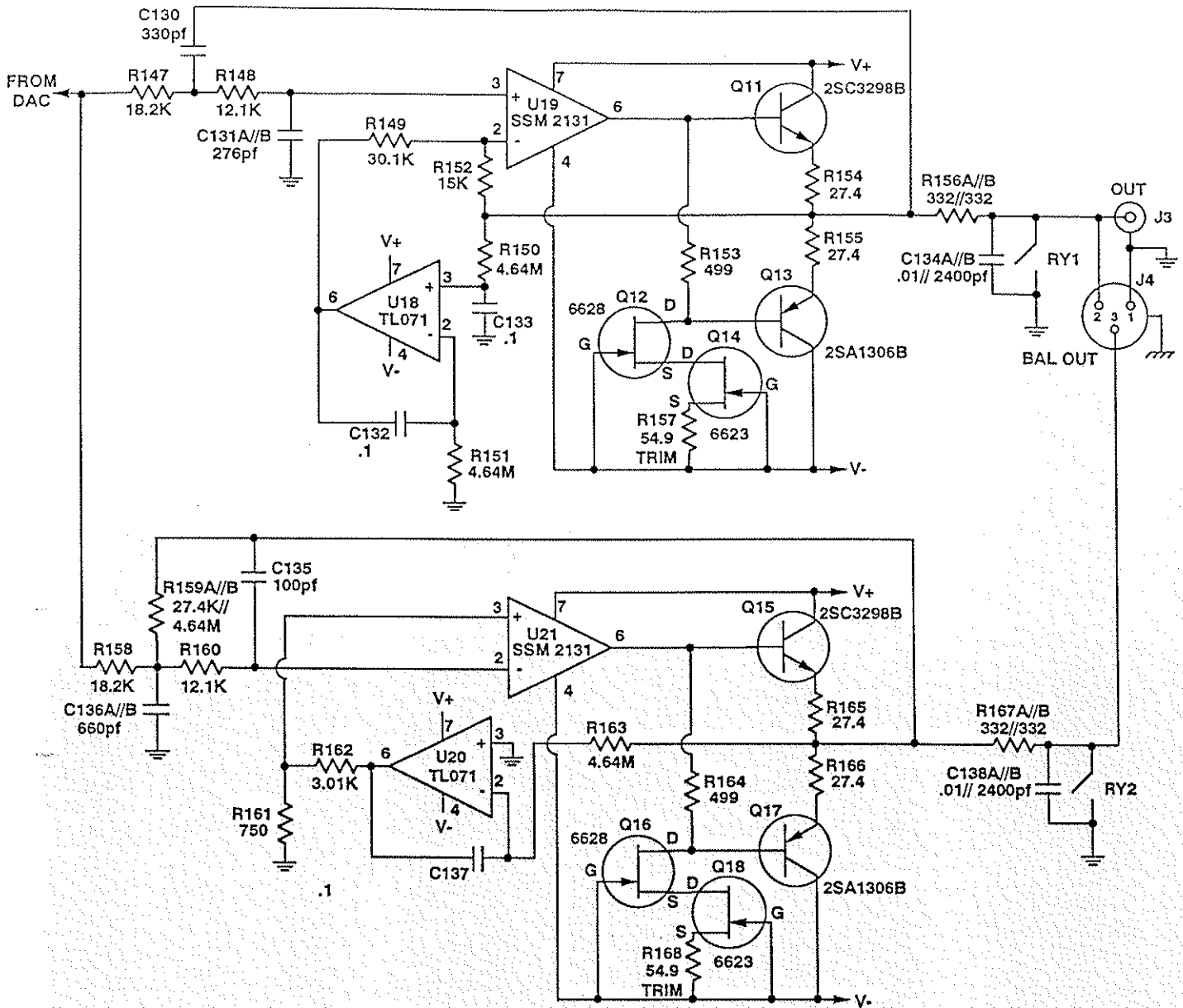

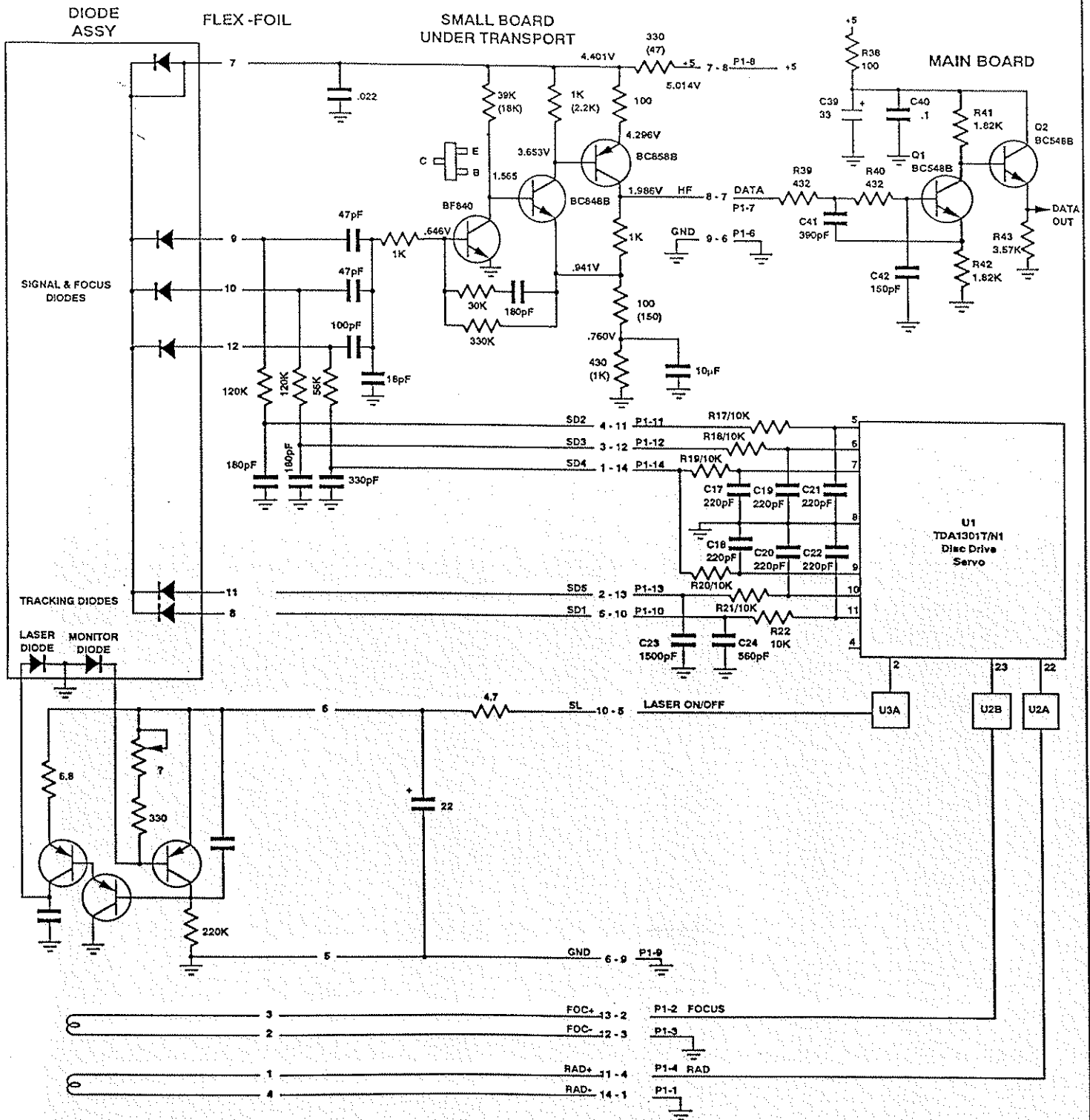

AUDIO RESEARCH CORPORATION
 5740 GREEN CIRCLE DRIVE
 MINNETONKA, MN 55343-4424

CD1 TRANSPORT
 Page 5 of 5
 3-18-94

PROPRIETARY NOTICE: THIS DRAWING CONTAINS PATENTED, PATENT APPLIED FOR, AND/OR OTHER CIRCUITRY CONSIDERED PROPRIETARY BY AUDIO RESEARCH CORPORATION AND IS FURNISHED ON A CONFIDENTIAL BASIS FOR IDENTIFICATION PURPOSES ONLY.

PARTS LIST

As of MAR31 94

PRODUCT: CD1

NOTES:

Schematic Symbol	Quantity	ARC Part #	Description
D DIODES			
D1-5,11,12,19,20	9	30500910	1N916B
D6-10,13-18	11	30500400	IN4005 GENERAL INSTRUMENT
F FUSES			
F1,2	2	34500004	FUSE 160MA RADIAL
F3	1	34500121	FUSE, MDQ 3/10 SL. BL.220
FL1	1	59000001	LINE FILTER
FTD1	1	33000100	DISPLAY PANEL
IR1	1	34100300	IR RECEIVER, SHARP
J CONNECTORS			
J1A,4A	3	23201981	NEUTRIK DH-NM NICKEL HOUSING
J1B,4B	3	23201982	NEUTRIK 3MD-H-I-B HORIZONTAL M
J2	1	23202200	CONNECTOR,BNC
J3	1	23201509	CHASSIS JACK,RED
J3	1	23201510	CHASSIS JACK,WHITE
L INDUCTORS			
L1-8	8	61000160	CHOKE, 2.7 UH +/- 10%
Q TRANSISTORS			
Q1,2	2	30010500	TRANSISTOR, BC548B
Q3,9,10	3	30003000	TRANSISTOR,2N5087 PNP
Q4	1	30006812	FET, YELLOW GRAY
Q5	1	30007029	FET, GRAY WHITE
Q6,7,8	3	30003100	TRANSIST.,2N5088,2N5209,2N5210
Q11,15	4	30010100	2SC3298B
Q12,16	4	30006628	FET, VIOLET RED GRAY
Q13,17	4	30010000	2SA1306B
Q14,18	4	30006623	FET, VIOLET RED ORANGE
R RESISTORS			
R1,11,32,77,81	5	42221102	RES. 22.1 OHM MK-2 1% 50 PPM
R2,3,7,8,27,28,140	7	42150402	RES. 15.0K MK-2 1% 50 PPM
R4,6,12,17-25,31,34,53-55,59-61,64	27	42100402	RES. 10K MK-2 1% 50 PPM
R 66-70,143			
R5,10,30	3	42698302	RES. 6.98K MK-2 1% 50 PPM
R9,145	2	42464302	RES. 4.64K MK-2 1% 50 PPM
R13,16,29,33,35,37,57,105,107	9	42475002	RES. 4.75 OHM MK-2 1% 50 PPM

PARTS LIST

As of MAR31 94

PRODUCT: CD1

NOTES:

Schematic Symbol	Quantity	ARC Part #	Description
C CAPACITORS			
C1,4,7,9,12,14,16,25,28,30,33,34,38 C 40,48,51-53,55,57	20	52100500	CAP. 0.1 UF 100V
C2,5	2	52180200	CAP. 180PF CERAMIC
C3	1	52270300	CAP. 2700PF CERAMIC
C6,8,11,13,15,27,29,39,49,125	10	50330701	CAP. 33UF 16V
C10	1	52390300	CAP. 3900PF CERAMIC
C17-22	6	52220200	CAP. 220PF CERAMIC
C23	1	52150300	CAP. 1500PF CERAMIC
C24	1	52560200	CAP. 560PF CERAMIC
C26,44	2	52220300	CAP. 2200PF CERAMIC
C31	1	52330400	CAP. .033UF CERAMIC
C32,126	2	50330801	CAP. 330UF 16V
C35	1	52470301	CAP. 4700PF CERAMIC
C36,50,54,114,115,118-121,124	10	52220401	CAP. .022UF CERAMIC
C37	1	50100804	CAP. 100UF 10V
C41	1	52390200	CAP. 390PF CERAMIC
C42	1	52150200	CAP. 150PF CERAMIC
C43	1	52470100	CAP. 47PF CERAMIC
C45,128	2	52330501	CAP. .33UF CERAMIC
C46,70	2	50100601	CAP. 1UF 63V
C47	1	52330100	CAP. 33PF CERAMIC
C56,60,63,66,69,77,83	7	50470701	CAP. 47UF 35V
C58,61,64,67,102,103,134A,138A	10	53100410	CAP. .01 UF 400V MKP10
C59,62,65,68	4	53100506	CAP. .1 UF 160V
C71,72	2	53470304	CAP. 4700 PF STY.
C73	1	52220100	CAP. 22PF CERAMIC
C74,75	2	52100100	CAP. 10PF CERAMIC
C76,79,81,82,85,86	6	52100500	CAP. 0.1 UF 100V
C78,80,84,87,90-93,112,113	10	52100400	CAP. .01 UF 200V
C88,89	2	50220703	CAP. 22UF 40V
C94,95	2	50220904	CAP. 2200 UF 63V.
C96-99	4	50220701	CAP. 22 UF 100V
C100,101,104-107	6	53220507	CAP. .22 UF 10% 160V
C108,109	2	53470402	CAP. 0.047 UF 160V 10%
C110,111	2	53220601	CAP. 2.2 UF 160V 10% MKP10
C116	1	50220801	CAP. 220UF 50V
C117	1	50220702	CAP. 22UF 50V
C122	1	50330901	CAP. 3300UF 16V
C123	1	50100913	CAP. 1000UF 16V
C127	1	52470500	CAP. .47UF CERAMIC
C129	1	52500300	CAP. .005 UF 20% CERAMIC DISC
C130	2	53330201	CAP. 330 PF ±2.5% 630V PPN
C131A	2	53220201	CAP. 220 PF ±2.5% 630V PPN
C131B	2	53560103	CAP. 56 PF +/-2% 630V DPN
C132,133,137	6	53100505	CAP. .1 UF 10% 63V
C134B,138B	4	53240305	CAP. .0024 PF 2% 630V
C135,136B	4	53100202	CAP. 100 PF +/-2 1/2% 630 V PPN
C136A	2	53560201	CAP. 560 PF +/-2.5% 630V

PARTS LIST

As of MAR 31 94

PRODUCT: CD1

NOTES:

Schematic Symbol	Quantity	ARC Part #	Description
R14,15,48,50,58,137	6	42100302	RES. 1K MK-2 1% 50 PPM
R26,93	2	42100602	RES. 1 MEG 1% MK2 50PPM
R36,46,49,62,63,65,108-112,114,146	13	42221402	RES. 22.1K MK-2 1% 50 PPM
R38,44,96	3	42100202	RES. 100 OHM MK-2 1% 50 PPM
R39,40	2	42432202	RES. 432 OHM MK-2 1% 50 PPM
R41,42,91,92	4	42182302	RES. 1.82K MK-2 1% 50 PPM
R43	1	42357302	RES. 3.57K MK-2 1% 50 PPM
R45,52,138	3	42221302	RES. 2.21K MK-2 1% 50 PPM
R47	1	42562202	RES. 562 OHM MK-2 1% 50 PPM
R51,142	2	42221602	RES. 2.21 MEG 1% MK-2 50PPM
R56	1	42215502	RES. 215K MK-2 1% 50 PPM
R71,72,75,76	4	42121402	RES. 12.1K 1% MK2 50PPM
R73,82,83,89,90,95,100-102,104	10	42100002	RES. 1 OHM MK-2 1% 50 PPM
R74,103	2	42825302	RES. 8.25K MK-2 1% 50 PPM
R78,106,141	3	42475402	RES. 47.5K MK-2 1% 50 PPM
R79,80,98,133	4	42100502	RES. 100K MK-2 1% 50 PPM
R84,94,99	3	42110202	RES. 110 OHM MK-2 1% 50 PPM
R85-88,116-119,157,168,	12	42549103	RES. 54.9 OHM 1% MK-3 50PPM
R97	1	42499202	RES. 499 OHM MK2 1% 50 PPM
R113	1	42332302	RES. 3.32K MK-2 1% 50 PPM
R115,139	2	42221502	RES. 221K MK-2 1% 50 PPM
R120,121,152	4	42150403	RES. 15K 1% MK-3 50PPM
R122,123	2	42536303	RES. 5.36K 1% MK-3 50PPM
R124A,125A	2	42118403	RES. 11.8K 1% MK-3 50PPM
R124B,125B	2	42130403	RES. 13K 1% MK-3 50PPM
R126A,126B,127A,127B,159A	6	42274403	RES. 27.4K 1% MK-3 50PPM
R128,129,156A,156B,167A,167B	10	42332203	RES. 332 OHM 1% MK-3 50PPM
R130A,130B,131A,131B	4	42432003	RES. 4.32 OHM 1% MK-3 50PPM
R132	1	42100103	RES. 10 OHM 1% MK-3 50PPM
R134,135	2	42100303	RES. 1K 1% MK-3 50PPM
R136	1	42475202	RES. 475 OHM MK-2 1% 50 PPM
R144	1	42332402	RES. 33.2K MK-2 1% 50 PPM
R147,158	4	42182413	RES. 18.2K 1% MK-4 50PPM
R148,160	4	42121403	RES. 12.1K 1% MK-350PPM
R149	2	42301403	RES. 30.1K 1% MK3 50PPM
R150,151,159B,163	8	42464603	RES. 4.64 MEG. 1% MK-3 50PPM
R153,164	4	42499203	RES. 499 OHM 1% MK-3 50PPM
R154,155,165,166	8	42274103	RES. 27.4 OHM1% MK-3 50PPM
R161	2	42750203	RES. 750 OHM 1% MK-3 50PPM
R162	2	42301303	RES. 3.01K 1% MK-3 50PPM

RY RELAYS

RY1,2	4	64101010	RELAY, 5V DAC1
-------	---	----------	----------------

SW SWITCHES

SW1	1	24200700	SWITCH,PUSH BUTTON,D240
-----	---	----------	-------------------------

PARTS LIST

As of MAR 31 94

PRODUCT: CD1

NOTES:

Schematic Symbol	Quantity	ARC Part #	Description
T TRANSFORMERS			
T1	1	60009300	XFR. DIGITAL
T2	1	60011500	XFR. CD1 120V
T3,4	2	60010300	XFR. PULSE PE65612
U INTEGRATED CIRCUITS			
U1	1	31005900	DISC DRIVE SERVO PHILLIPS
U2,3,7	3	31005800	DUAL POWER OP AMP
U4	1	31006000	DATA MICROPROCESSOR PHILLIPS
U5	1	31006100	CONTROL MICROPROCESSOR PHILLIPS
U6	1	31006300	D-RAM MEMORY 8-16 DECODE
U8	1	34100010	TOTX176
U9	1	34100200	GLASS TRANSMITTER, AT&T
U10	1	31005620	QUAD D FLIP-FLOP
U11	1	31005700	LINE DRIVER, AM26LS31PC
U12	1	31003300	IC, HEX INVERTER
U13	1	31006200	DISPLAY DRIVER
U14,15	2	31002200	MC34071P
U16	1	31002700	MC7915 CT MOT.
U17	1	31002910	IC, 5V REGULATOR
U18,20	4	31001901	TLO71CP TESTED(RED LINE)
U19,21	4	31002310	IC, SSM2131P
X CRYSTALS			
X1	1	27000300	8.46MHZ RESONATOR
X2,4	2	27000200	4MHZ RESONATOR
X3	1	27000010	16.9344MHZ CRYSTAL
ZD ZENER DIODES			
ZD1,12	2	30505300	3.9V ZENER
ZD2,3	2	30504400	IN5240B
ZD4,5	2	30504210	IN5535A (KNOX ONLY)
ZD6-9	4	31000705	LM329DZ GREEN
ZD10	1	30505000	7.5V ZENER
ZD11	1	30504900	11V ZENER
ZD13	1	30505100	6.8V ZENER