

120/240
VAC
50-60 HZ

TRANSFORMER PRIMARY WIRING	
VOLTAGE	LEAD CONNECTIONS
120 VAC	BLU TO BLK, BLK/WHT TO BLU/WHT
240 VAC	BLK/BLU TO BLU/WHT

(120 VAC WIRING SHOWN)

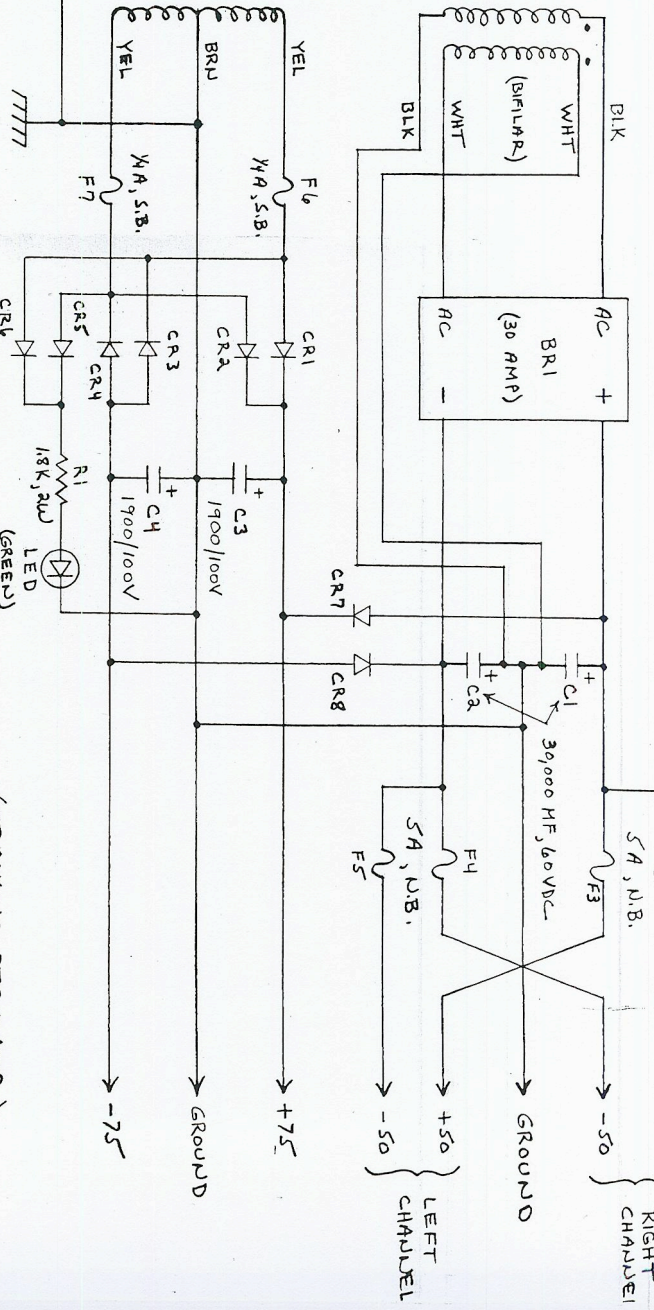
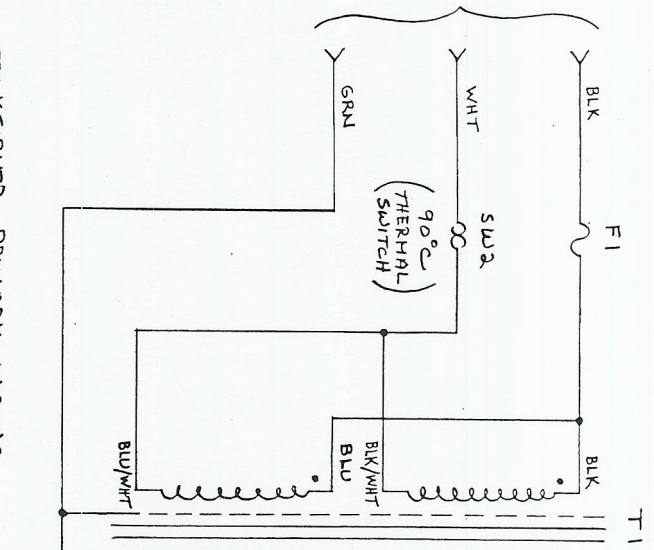

- NOTES:
1. CR1 - CR8 ARE 1N4003
 2. BRI = VARO VK2Y8
 3. SW2 MOUNTED ON HEAT SINK ASSEM.
 4. F6, F7, CR1-K, FRI ARE ON PWB 16017110
 5. ALL CAP. 10 MF RES. W/D UNLESS NOTED
 6. Q37, 38 ARE M.P., P/N 30001100 \$ 30002100
 7. Q39, 40 ARE M.P., P/N 30002400 \$ 30002500

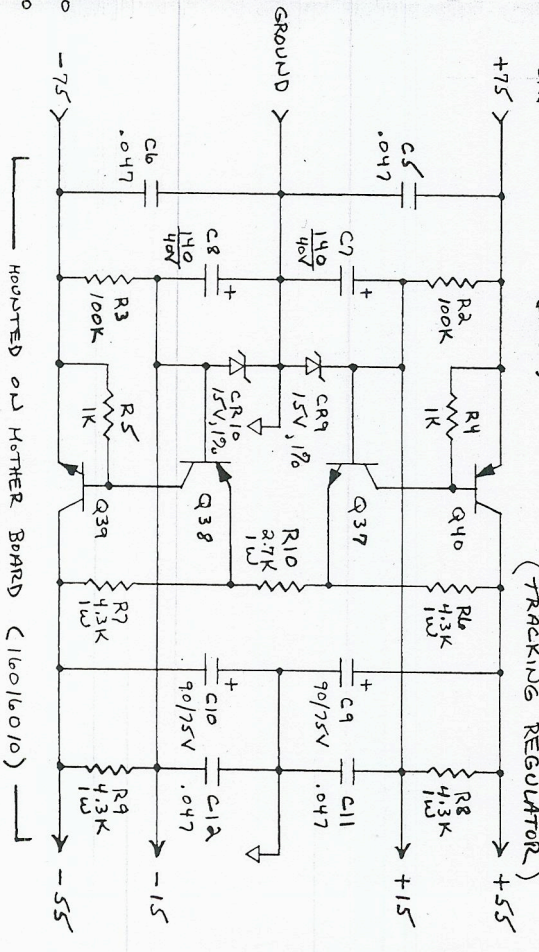

D100A PARTS LIST

COMPONENT	QUAN.	DESCRIPTION	VALUE	RATING	TOL.	OUR PART NO.
AM1	2	Type AM1, Analog Module				AM-1
AM2	2	Type AM2, Analog Module				AM-2
U1, U2	2	LM308N Op-Amp				31000300
Q1, 2, 7, 8, 39	5	NPN				300024XX
Q3, 4, 5, 6, 40	5	PNP				300025XX
Q9-14, 27-32	12	PNP				300027XX
Q15-26	12	NPN				300026XX
Q33, 34, 37	3	NPN				30001100
Q35, 36, 38	3	PNP				30002100
CR1-8, 21-24	12	1N4003				30501700
BR1	1	VK248				30501900
R1	1	Carbon Comp.	1.8K	2W	5%	41180305
R2, R3	2	Carbon Comp.	51K	1/2W	5%	41510403
R4, 5, 23-30	10	Metal Film	1K	1/4W	1%	42100302
R6-9	4	Metal Film	4.3K	1W	2%	46430304
R10	1	Metal Film	2.7K	1W	2%	46270304
R13, R14	2	Metal Film	38.3Ω	1/4W	1%	42383102
R15, R16	2	Carbon Comp.	36K	1/4W	5%	41360402
R17-20	4	Metal Film	1.3K	2W	2%	46130305
R21, R22	2	Carbon Comp.	62Ω	1/4W	5%	41620102
R11, 12, 31, 32	4	Carbon Comp.	1K	1/4W	5%	41100302
R33-36	4	Carbon Comp.	1.6M	1/4W	5%	41160602
R37	1	Metal Film	1K	2W	2%	46100305
R38	1	Metal Film	1.6K	2W	2%	46160305
R39, R40	2	Carbon Comp.	200Ω	1/4W	5%	41200202
R41, R42	2	Carbon Comp.	10Ω	1/4W	5%	41100102
R43, 44, 51, 52	4	Metal Film	237Ω	1/4W	1%	42237202
R45, 46, 53, 54	4	Metal Film	10Ω	1/4W	1%	42100102
R47-50	4	Metal Film	5.1K	1W	2%	46510304
R55-104	50	Carbon Comp.	2.7Ω	1W	5%	41270004
CR9, CR10	2	0.5M15ZS1	15V	500MW	1%	30501800
CR11, CR12	2	1N5234B	6.2V	500MW	5%	30502100
CR13-20	8	1N914				30500900
C1, C2	2	Electrolytic	30,000μF	60V	-10/+75%	50301000
C3, C4, 37, 38	4	Electrolytic	1900μF	100V	-10/+75%	50190900
C5, 6, 11, 12, 21, 22	6	Metalized Mylar	.047μF	200V	10%	53470401
C7, C8	2	Electrolytic	140μF	40V	-10/+75%	50140801
C9, C10	2	Metalized Mylar	1.0μF	100V	-10/+75%	53100600
C13, C14	2	Dipped Silver Mica	390pF	500V	5%	57390200
C15, C16	2	Metalized Mylar	.0012μF	200V	10%	53120301
C17, C18	2	Dipped Silver Mica	100pf	500V	5%	57100201
C19, C20	2	Metalized Mylar	5.0μF	200V	10%	53500601
C23, C24	2	Metalized Mylar	.0027μF	200V	10%	53270301
C25-36	8	Metalized Mylar	.1μF	200V	10%	53100503
C31-34	4	Metalized Mylar	.47μF	200V	10%	53470504
F1	1	Slo-Blo	4A	125V		34500701
F1	1	Slo-Blo	2A	250V		34501301
F2-5	4	Normal Blow	6A	250V		34500600
F6, F7	2	Slo-Blo Pigtail	1/4A	250V		34500101
T1	1	AM8009				60003101
SW1	1	MSS-204NG				24100500
SW2	1	3450-056-077				24300100
LED	1	3505G - Green				34300100
J1, J2	2	Phono Jack				23201000
J3, J4	2	Binding Post - Red				23102500
J5, J6	2	Binding Post - Black				23102600