

AUDIO RESEARCH CORPORATION
 SP15 PREAMPLIFIER SCHEMATIC
 PAGE 1 of 7

SEE PATENT, PROPRIETARY, & COPYRIGHT NOTICES ON PAGE 7

SEE PATENT, PROPRIETARY, & COPYRIGHT NOTICES ON PAGE 7

AUDIO RESEARCH CORPORATION
SP15 PREAMPLIFIER SCHEMATIC
PAGE 2 of 7

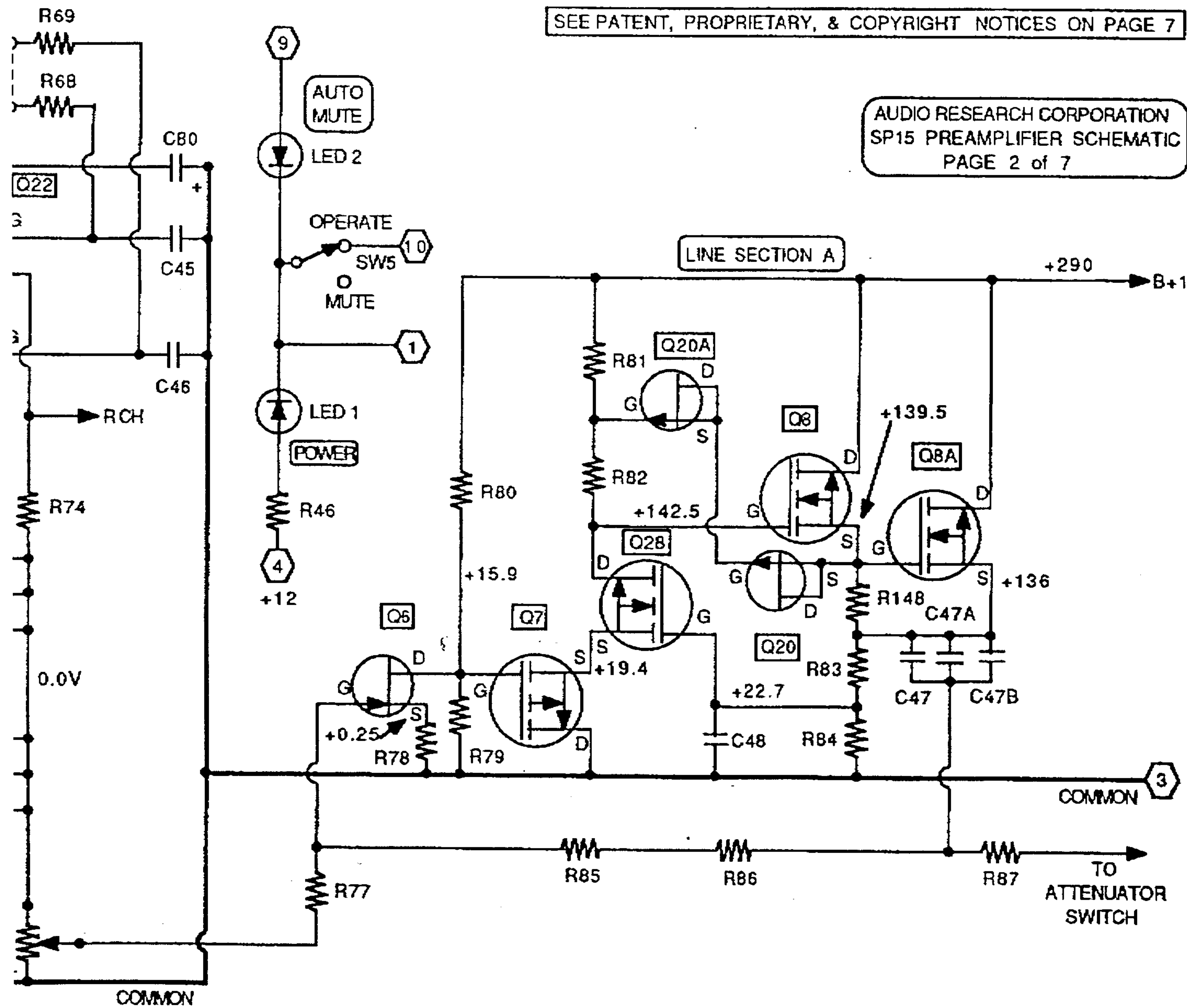

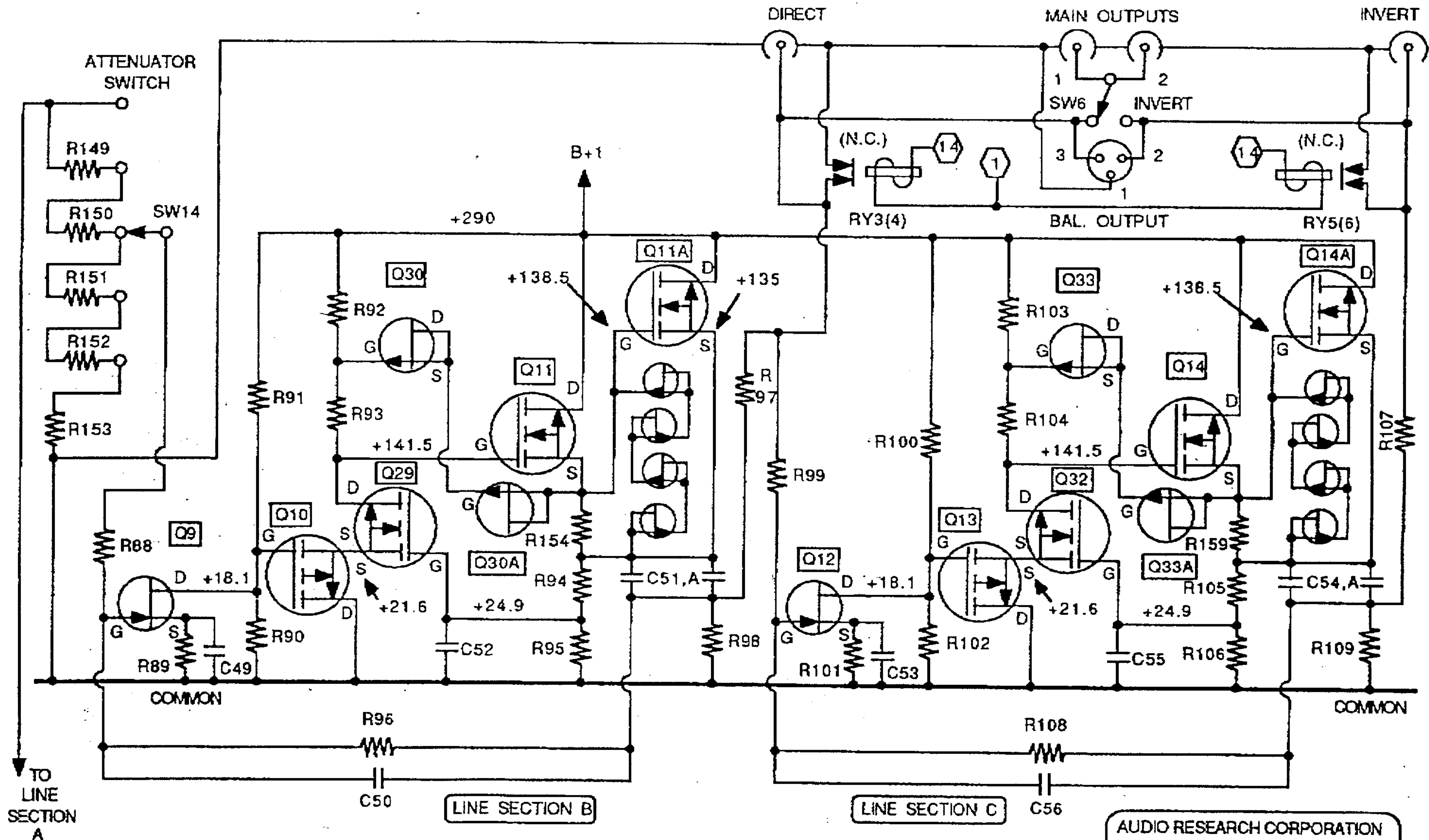

SEE PATENT, PROPRIETARY, & COPYRIGHT NOTICES ON PAGE 7

AUDIO RESEARCH CORPORATION
 SP15 PREAMPLIFIER SCHEMATIC
 PAGE 3 of 7

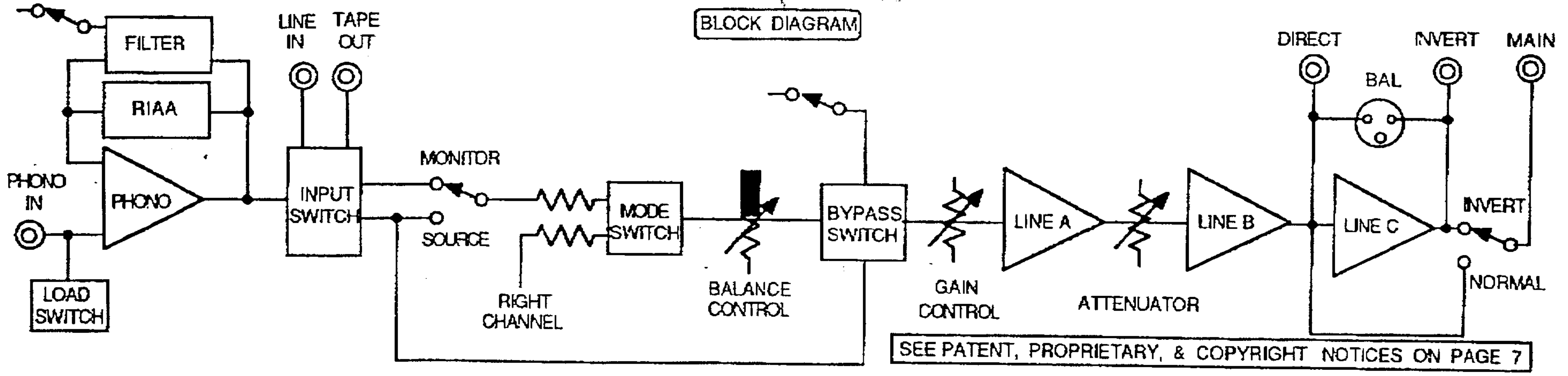
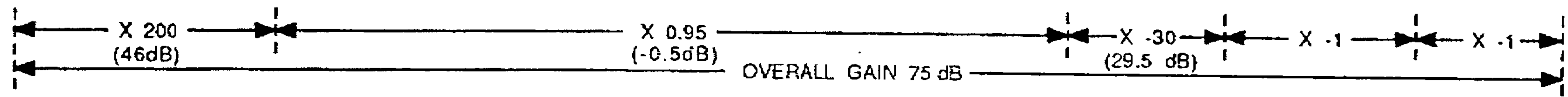
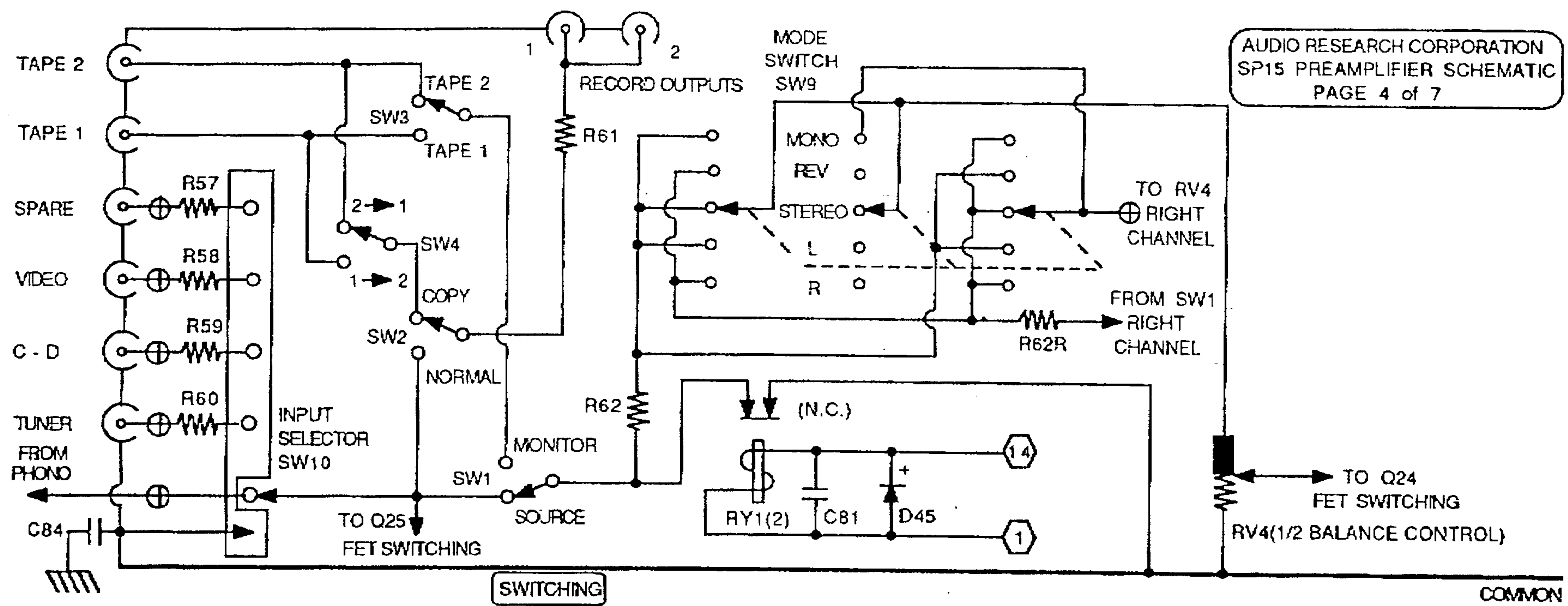

SEE PATENT, PROPRIETARY, & COPYRIGHT NOTICES ON PAGE 7

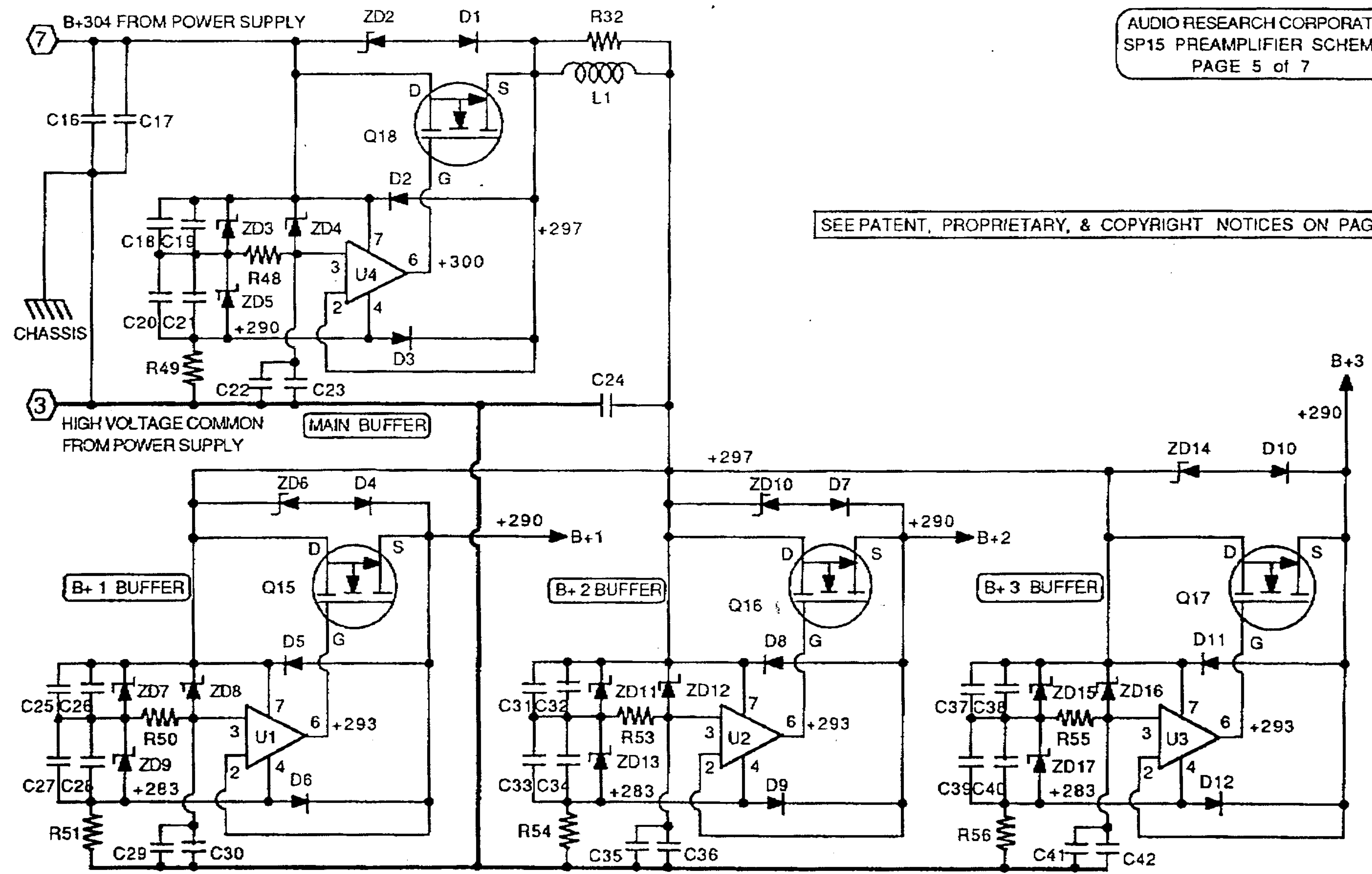

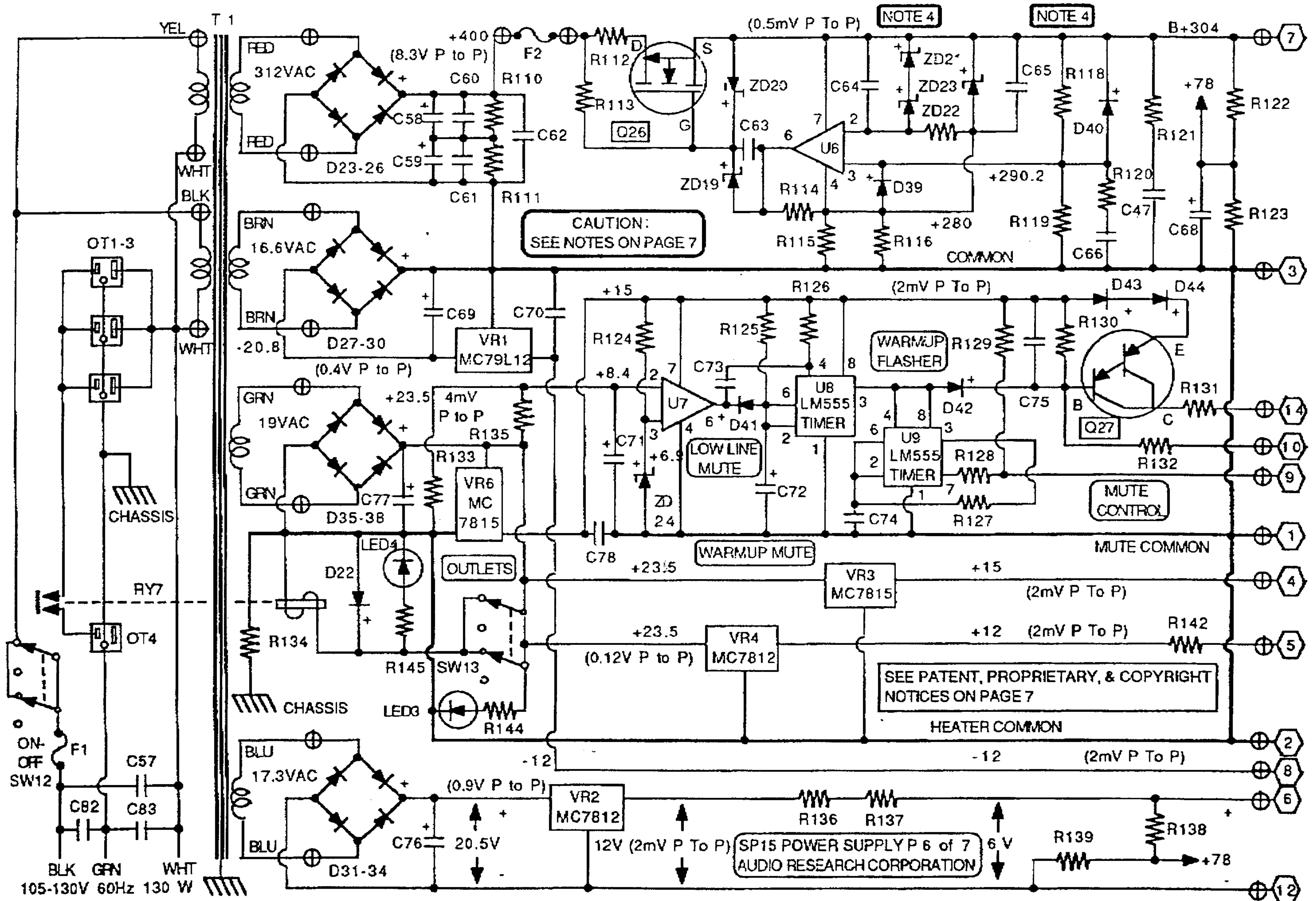

AUDIO RESEARCH CORPORATION

6801 SHINGLE CREEK PARKWAY
MINNEAPOLIS, MN 55430

**SP15 PREAMPLIFIER
NOTES**



August 17, 1988
Page 7 of 7 pages

PROPRIETARY AND PATENT NOTICE:

PROPRIETARY NOTICE: THESE DRAWINGS CONTAINS PATENTED, PATENT APPLIED FOR, AND/OR OTHER CIRCUITRY CONSIDERED PROPRIETARY BY AUDIO RESEARCH CORPORATION AND ARE FURNISHED ON A CONFIDENTIAL BASIS FOR IDENTIFICATION AND SERVICE PURPOSES ONLY.

© COPYRIGHT 1988

NOTES: (Apply to all pages of Schematic Information)

1. CAUTION: HIGH VOLTAGE. CONTACT WITH STORED ENERGY EVEN WITH POWER OFF CAN BE LETHAL.
2. VOLTAGES SHOWN ARE WITH POWER LINE AT 120 VOLTS, 60 HZ, UNITS CONNECTED.
3.  DENOTES CABLE CONNECTION PIN NUMBER.
 DENOTES WIRE CONNECTION TO PWB.
4. R118, R118A MAY VARY, SELECT FOR 304 VOLTS + - 0.5 VOLT AT  TO MATCH THE ZD2, 22 USED.
5. MAKE ALL VOLTAGE MEASUREMENTS WITH 1KΩ RESISTOR AT TEST PROBE TO AVOID INSTABILITY.
6. "TRIM" RESISTORS MUST BE MATCHED TO APPROPRIATE FET OR FET GRADE. CONSULT FACTORY.

TRANSISTOR CONNECTIONS:

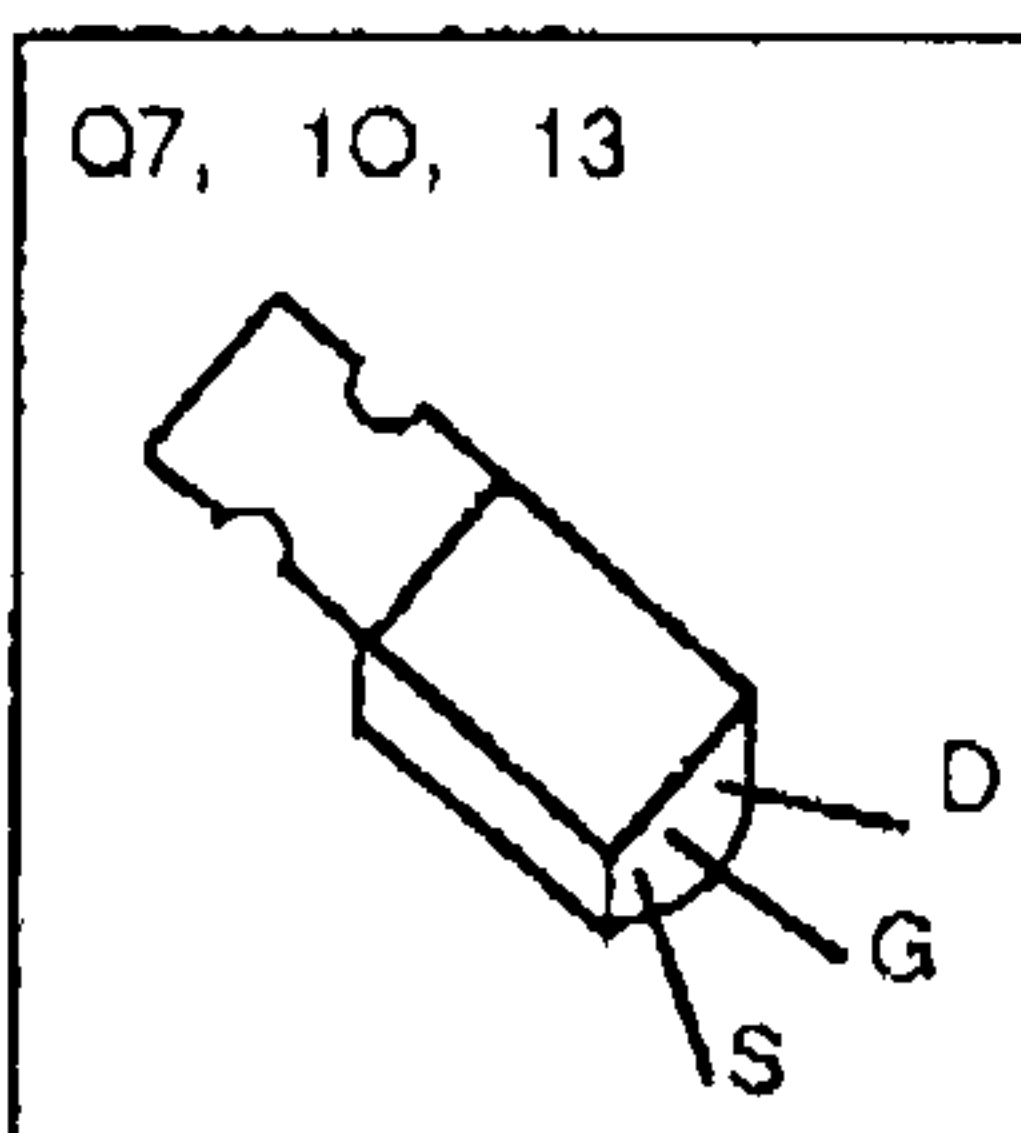
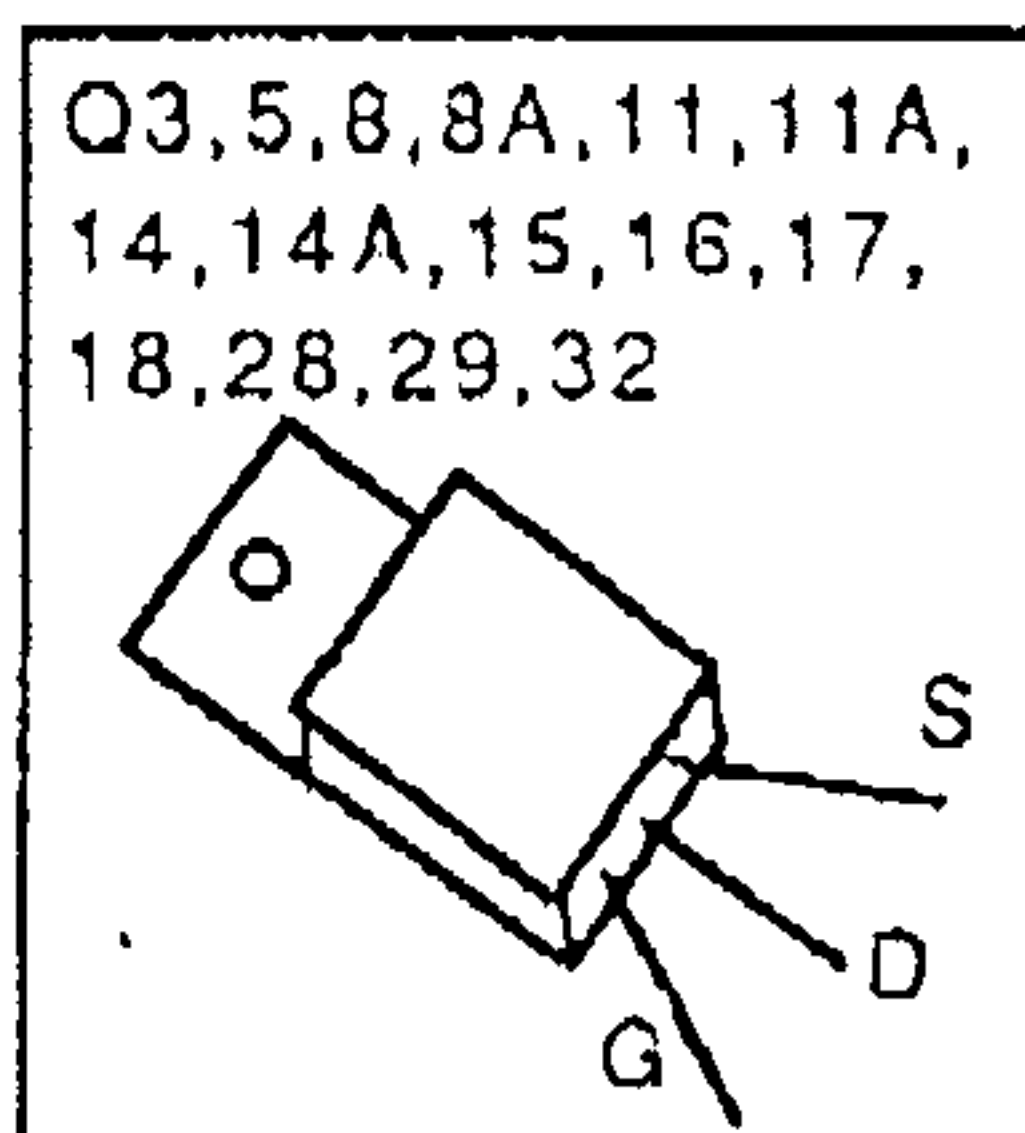
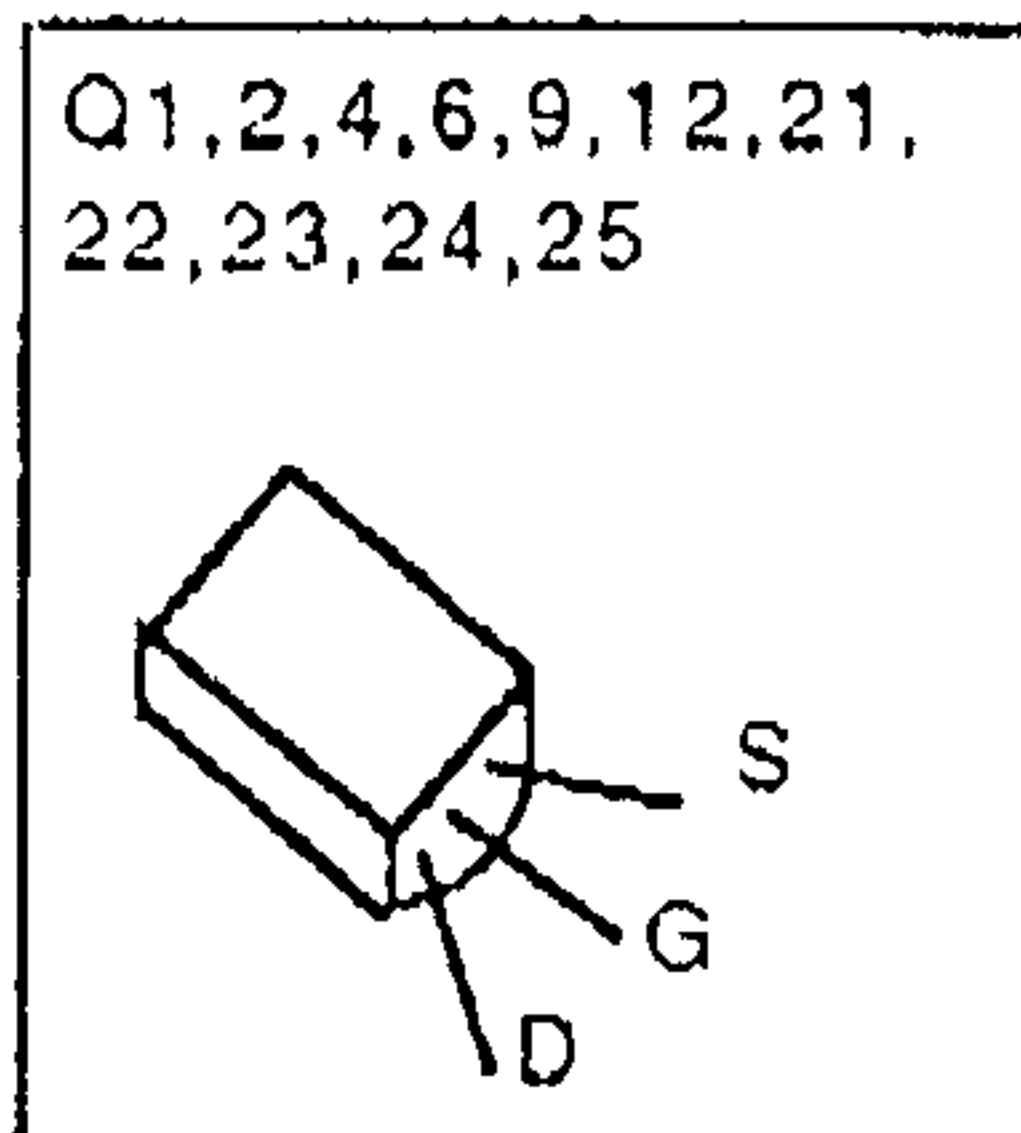

FILTER ADJUSTMENT: (RV1-L & R)

ADJUST FOR 0V DC+- 1mV ACROSS R31, WITH UNIT ON FOR 30 MINUTES PRIOR TO ADJUSTMENT, ALSO SET SW5 TO MUTE, SW8 (FILTER) ON, SW10 AT PHONO, SW11 (LOAD SWITCH) AT 30Ω PRIOR TO ADJUSTMENT.

