

LEFT CHANNEL SHOWN
RIGHT CHANNEL NUMBERS
IN PARENTHESES

SELECTOR SWITCH
1. MAG PHONO
2. TAPE
3. TUNER
4. AUX 1
5. AUX 2

J2 TAPE
J3 TUNER
J4 AUX 1
J5 AUX 2
J6 MONITOR INPUT
J7 TAPE OUTPUT

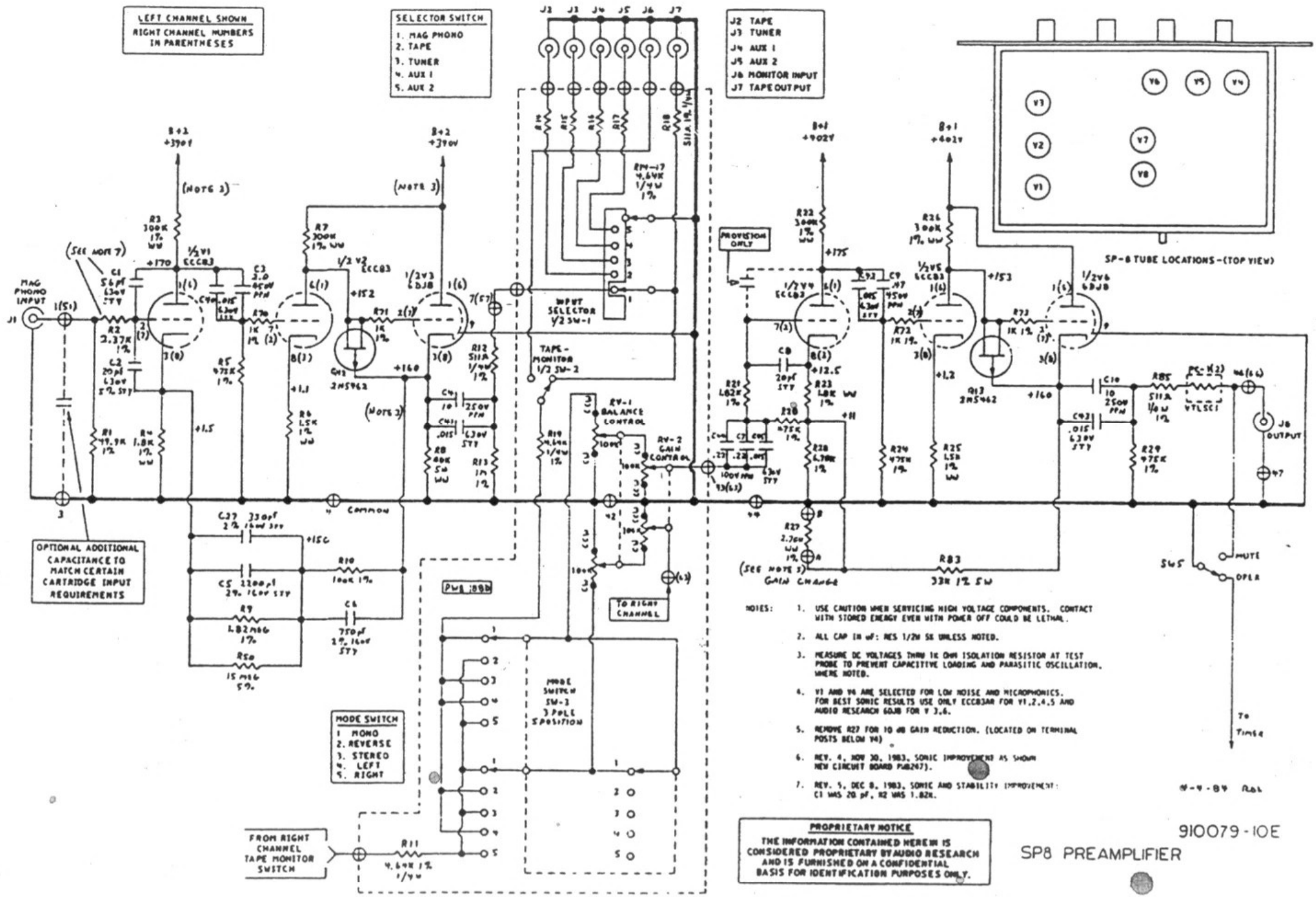

OPTIONAL ADDITIONAL CAPACITANCE TO MATCH CERTAIN CARTRIDGE INPUT REQUIREMENTS

MODE SWITCH
1. MONO
2. REVERSE
3. STEREO
4. LEFT
5. RIGHT

- NOTES:
1. USE CAUTION WHEN SERVICING HIGH VOLTAGE COMPONENTS. CONTACT WITH STORED ENERGY EVEN WITH POWER OFF COULD BE LETHAL.
 2. ALL CAP IN μ F: RES 1/2W SR UNLESS NOTED.
 3. MEASURE DC VOLTAGES THRU 1K OHM ISOLATION RESISTOR AT TEST PROBE TO PREVENT CAPACITIVE LOADING AND PARASITIC OSCILLATION, WHERE NOTED.
 4. V1 AND V4 ARE SELECTED FOR LOW NOISE AND MICROPHONICS. FOR BEST SONIC RESULTS USE ONLY ECC83AR FOR V1, 2, 4, 5 AND AUDIO RESEARCH 604B FOR V3, 6.
 5. REMOVE R27 FOR 10 dB GAIN REDUCTION. (LOCATED ON TERMINAL POSTS BELOW V4)
 6. REV. 4, NOV 30, 1983, SONIC IMPROVEMENT AS SHOWN (NEW CIRCUIT BOARD P1B247).
 7. REV. 5, DEC 8, 1983, SONIC AND STABILITY IMPROVEMENT: C1 WAS 20 pF, R2 WAS 1.82K.

PROPRIETARY NOTICE
THE INFORMATION CONTAINED HEREIN IS CONSIDERED PROPRIETARY BY AUDIO RESEARCH AND IS FURNISHED ON A CONFIDENTIAL BASIS FOR IDENTIFICATION PURPOSES ONLY.

910079-10E
SP8 PREAMPLIFIER

4-9-84 Rdb