

LEFT CHANNEL SHOWN
RIGHT CHANNEL SHOWN
IN PARENTHESES

SELECTOR SWITCH

1. MAG PHONO
2. TAPE
3. TUNER
4. AUX 1
5. AUX 2

- J2 TAPE
- J3 TUNER
- J4 AUX 1
- J5 AUX 2
- J6 MONITOR INPUT
- J7 TAPE OUTPUT

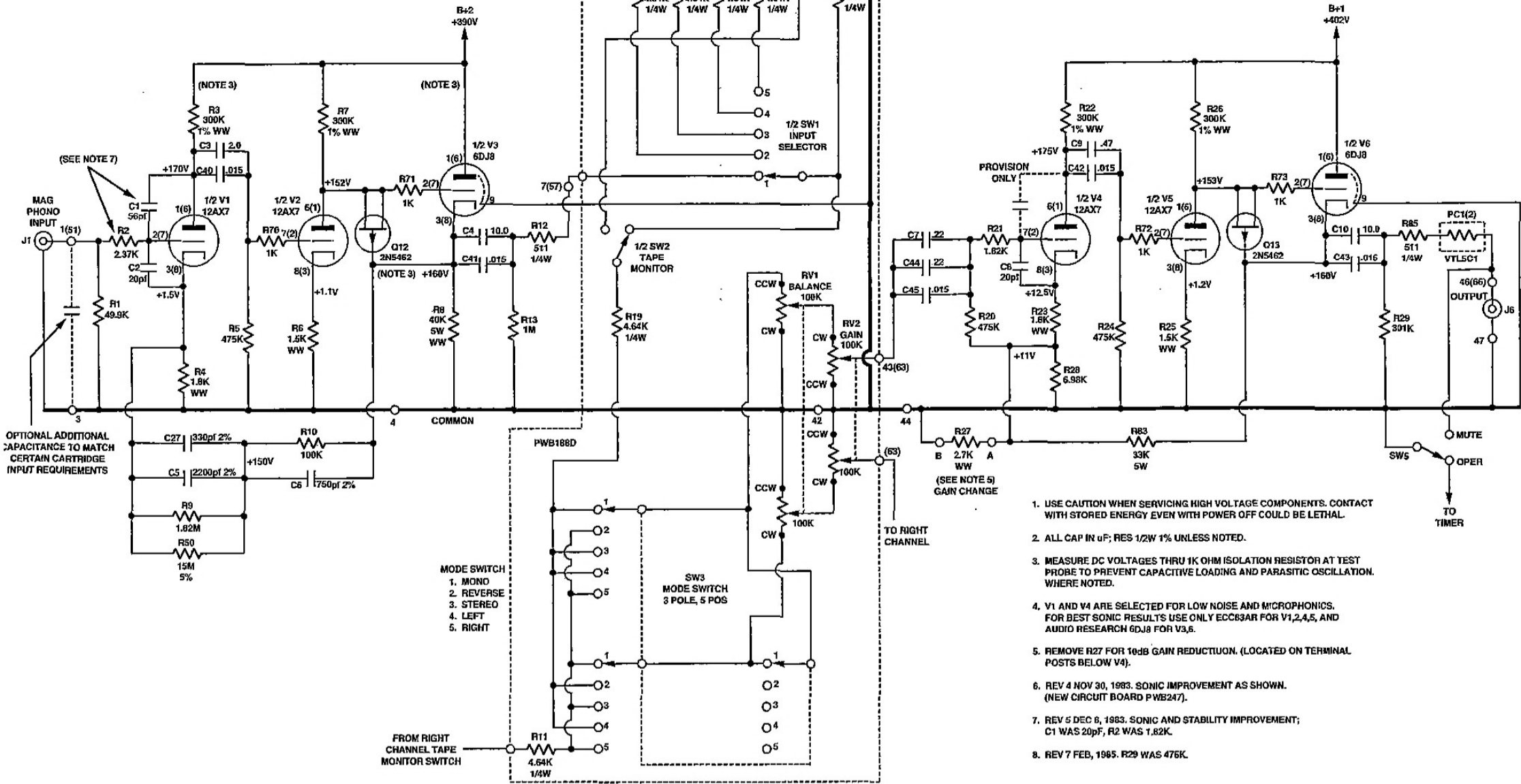

1. USE CAUTION WHEN SERVICING HIGH VOLTAGE COMPONENTS. CONTACT WITH STORED ENERGY EVEN WITH POWER OFF COULD BE LETHAL.
2. ALL CAP IN μF ; RES 1/2W 1% UNLESS NOTED.
3. MEASURE DC VOLTAGES THRU 1K OHM ISOLATION RESISTOR AT TEST PROBE TO PREVENT CAPACITIVE LOADING AND PARASITIC OSCILLATION. WHERE NOTED.
4. V1 AND V4 ARE SELECTED FOR LOW NOISE AND MICROPHONICS. FOR BEST SONIC RESULTS USE ONLY ECC83AR FOR V1,2,4,5, AND AUDIO RESEARCH 6DJ8 FOR V3,6.
5. REMOVE R27 FOR 10dB GAIN REDUCTION. (LOCATED ON TERMINAL POSTS BELOW V4).
6. REV 4 NOV 30, 1983. SONIC IMPROVEMENT AS SHOWN. (NEW CIRCUIT BOARD PWB247).
7. REV 5 DEC 8, 1983. SONIC AND STABILITY IMPROVEMENT; C1 WAS 20pF, R2 WAS 1.82K.
8. REV 7 FEB, 1985. R29 WAS 475K.

SP8
AUDIO REV 7
PAGE 1 OF 2
12/27/01

AUDIO RESEARCH CORPORATION
3900 ANNAPOLIS LANE NORTH
PLYMOUTH, MN 55447-5447

PROPRIETARY NOTICE: THIS DRAWING CONTAINS PATENTED, PATENT APPLIED FOR, AND/OR OTHER CIRCUITRY CONSIDERED PROPRIETARY BY AUDIO RESEARCH CORPORATION AND IS FURNISHED ON A CONFIDENTIAL BASIS FOR IDENTIFICATION PURPOSES ONLY.