

53 COLLEGE ST
GLADESVILLE 2111

Australian Monitor P/L

| REVISEMENTS | MODEL | DRAWN BY |
|-------------|-------|----------|
| No | DATE | BY |
| 1 | | |
| 2 | | |
| 3 | | |
| 4 | | |

1K2

| REFERENCE | DATE |
|---------------|---------|
| CHANNEL A & B | 12/5/92 |
| DESCRIPTION | SCALE |
| PRE-AMPS | NIL |

NOTE: ALL RESISTORS ARE 0.6 WATT EXCEPT WHERE NOTED.

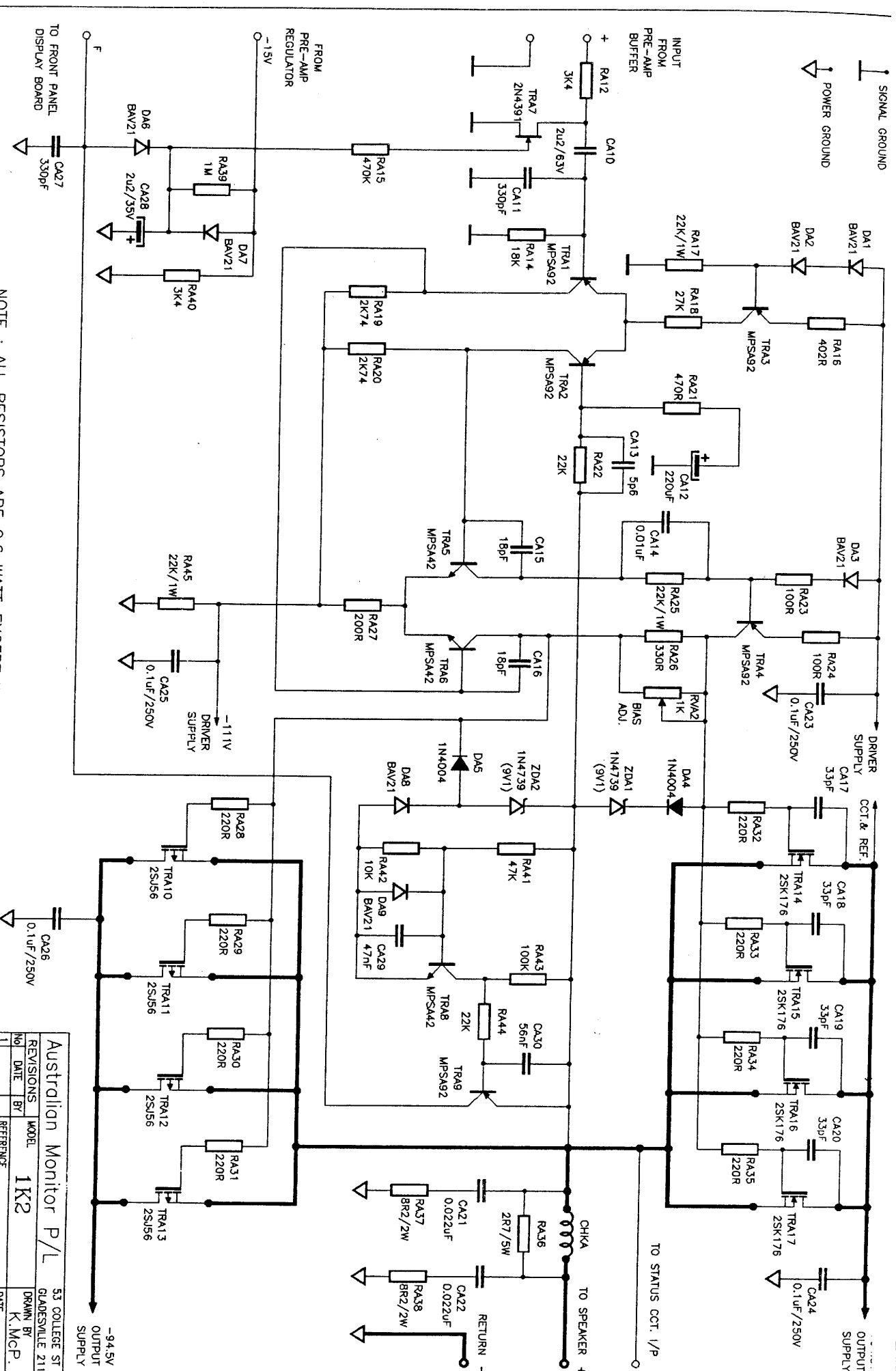

NOTE : ALL RESISTORS ARE 0.6 WATT EXCEPT WHERE NOTED.

| | | | |
|----------|------|--------------|------------------|
| REVISONS | | MODEL | 53 COLLEGE ST |
| 1 | DATE | 1K2 | GLADESVILLE 2111 |
| 2 | BY | REFERENCE | DRAWN BY |
| 3 | | CHANNEL A. | K. MCP. |
| 4 | | DESCRIPTION | SCALE |
| | | OUTPUT STAGE | NIL |

Australian Monitor P/L
 TO FRONT PANEL DISPLAY BOARD
 TO STATUS C.T. I/P
 TO SPEAKER
 RETURN
 -94.5V OUTPUT SUPPLY

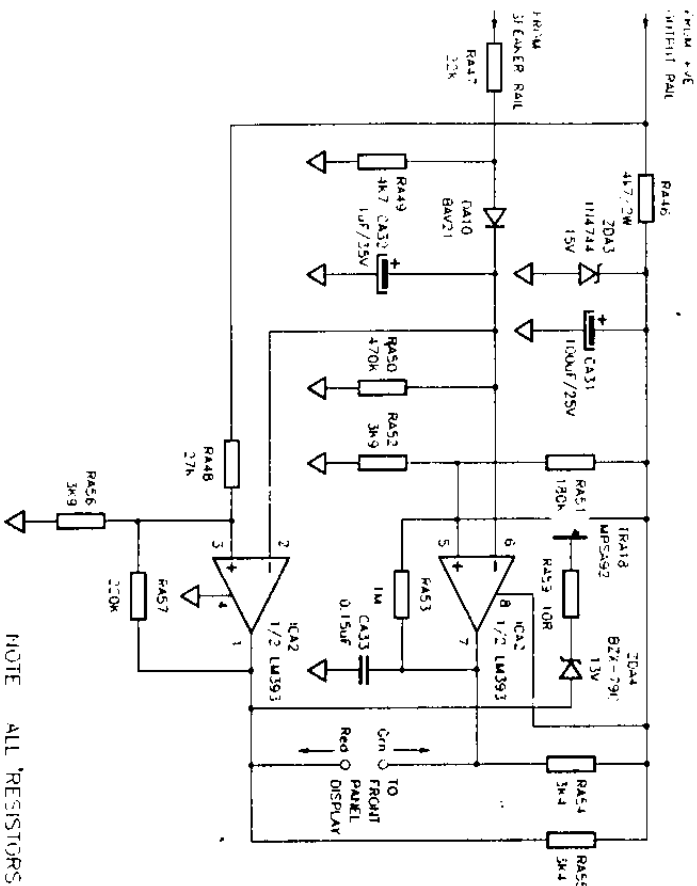

NOTE ALL RESISTORS ARE 0.6 WATT EXCEPT WHERE NOTED

CHA STATUS CIRCUIT

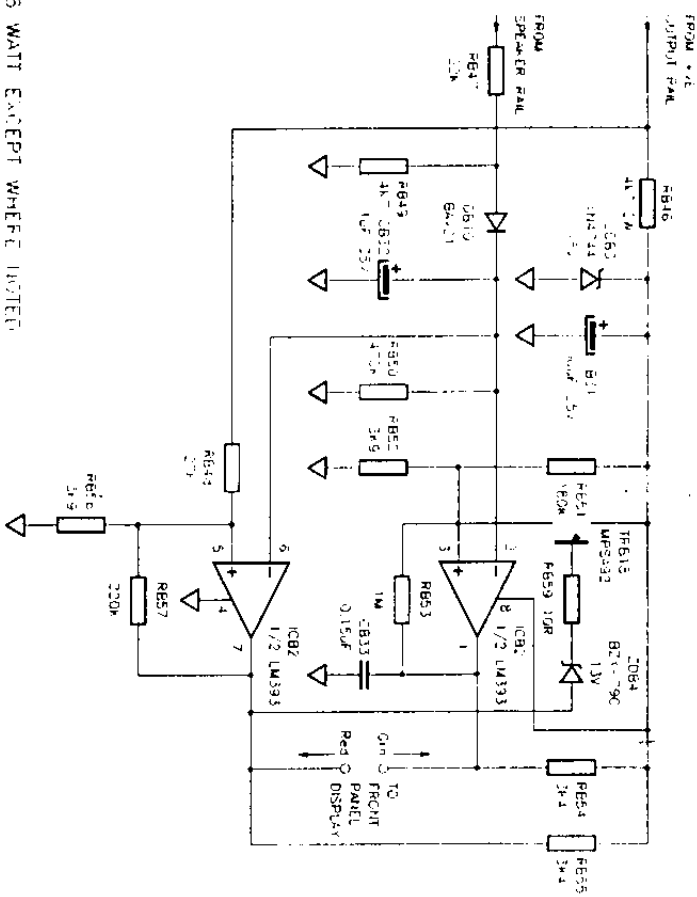

CHB STATUS CIRCUIT

| REV | DATE | BY | CHKD | APP. DATE |
|-----|------|----|------|-----------|
| 1 | | | | 17-11-97 |
| 2 | | | | |
| 3 | | | | |
| 4 | | | | |
| 5 | | | | |
| 6 | | | | |
| 7 | | | | |

| REV | DATE | BY | CHKD | APP. DATE |
|-----|------|----|------|-----------|
| 1 | | | | 17-11-97 |
| 2 | | | | |
| 3 | | | | |
| 4 | | | | |
| 5 | | | | |
| 6 | | | | |
| 7 | | | | |



Australian Monitor Pty. Ltd.
 122-124 E STREET
 MELBOURNE VIC 3000
 PH: 03 9584 1000

Module 1
 ASPECT
 DRAWING AND REFERENCING
12_STA
 STATUS CIRCUIT AND VALUES
 PA-12
 REV A
 DATE 17-11-97
 SHEET 4 OF 7

THIS DRAWING AND THE INFORMATION IT CONTAINS ARE IMPLIED TO BE THE SOLE PROPERTY OF AUSTRALIAN MONITOR PTY. LTD. AND SHALL BE REPRODUCED IN WHOLE OR IN PART WITHOUT PRIOR APPROVAL

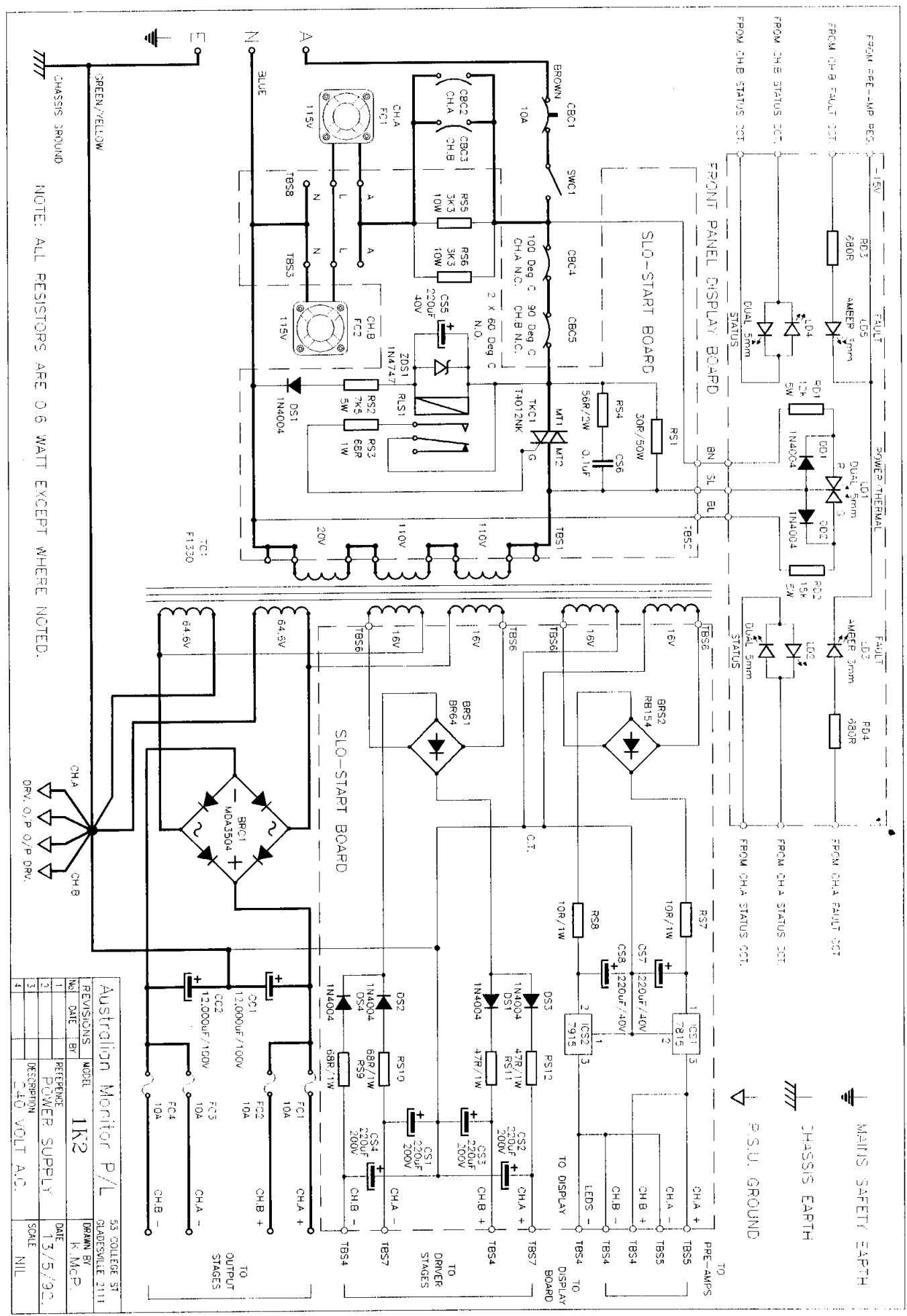

NOTE: ALL RESISTORS ARE 0.6 WATT EXCEPT WHERE NOTED.

| REVISIONS | | | | MODEL | DATE | BY | DRWN BY |
|-----------|--|--|--|--------------|---------------|----|----------|
| 1 | | | | 1K2 | | | K.M.C.P. |
| 2 | | | | POWER SUPPLY | 13/5/92 | | |
| 3 | | | | DESCRIPTION | 240 VOLT A.C. | | |
| 4 | | | | | | | |

| | |
|------------------------|-----------------------------------|
| Australian Monitor P/L | 53 COLLEGE ST GLADESVILLE 2111 |
| DATE | 13/5/92 |
| SCALE | NIL |