

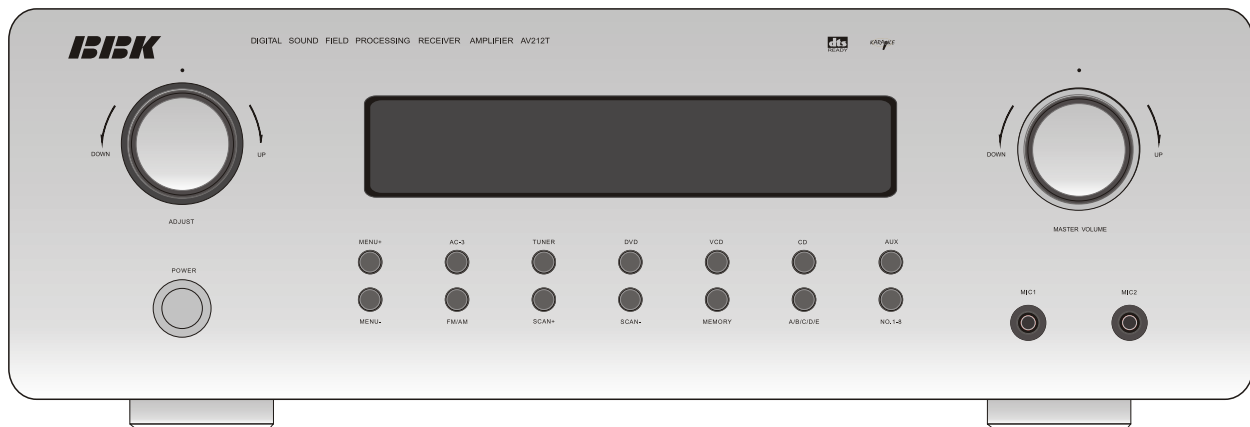

AV212T DIGITAL SURROUND HOME THEATRE AMPLIFIER

SERVICE MANUAL



BBK ELECTRONICS CORP., LTD.

SM 001/03

SAFETY PRECAUTIONS & IMPORTANT NOTES!

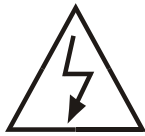

CAUTION: TO REDUCE THE RISK OF ELECTRIC SHOCK DO NOT REMOVE COVER (OR BACK) NO USER - SERVICEABLE PARTS INSIDE

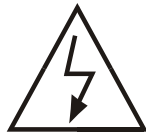

The lightning flash with arrowhead symbol, with an equilateral triangle, is intended to alert you to the presence of uninsulated “dangerous voltage” within the product's enclosure that may be of sufficient magnitude to constitute a risk of electric shock to persons.



The exclamation point within an equilateral triangle is intended to alert you to the presence of important operating and maintenance (servicing) instructions in the literature accompanying the appliance.

Voltages :220V AC,50/60Hz.

AV212T HOME THEATRE AMPLIFIER

SPECIFICATIONS

Output Power(RMS)

Standard Stereo:(20-20KHz, 0.1%THD 6ohm) 100W+100W

All five channel state 80W×5

Distortion of Total Harmonic

All channel <0.1% 1kHz 10W 8ohm

Signal-to-Noise Ratio

All channel >85dB

Frequency Responce

All channel 20Hz-20kHz +0.5,-0.5dB

Input Sensitivity/Impedance

Microphone 0.5mv-100mv/2kohm

Line in 0.707v/51kohm

Input Sensitivity/Impedance

Radio 0.707v/51kohm

Out impedance

Recommended impedance 4-8ohm

The Separation Degree of All Channel

>45dB

Tuning Range

FM 87.5-108.0MHz

AM 530-1710Hz

Tuning Step

FM 50KHz

AM 9Hz/10Hz

Power

AC220-240V/50Hz

Max Power Consumption

300W

AV212T input board

no.	description			quantity/ unit	components position no.	additional explanation
	component name	specification	package			
1	carbon film resistor	47Ω 1/4W	FTP=10mm	1	R45	
2	carbon film resistor	100Ω 1/4W	FTP=10mm	1	R48	
3	carbon film resistor	470Ω 1/4W	FTP=10mm	20	R1、R2、R3、R4、R5、R6、R7、R8、R9、R10、R11、R12、R13、R14、R76、R77、R79、R100、R112、R115	
4	carbon film resistor	680Ω 1/4W	FTP=10mm	1	R29	
5	carbon film resistor	1K 1/4W	FTP=10mm	4	R81、R85、R88、R93	
6	carbon film resistor	2.2K 1/4W	FTP=10mm	2	R46、R47	
7	carbon film resistor	5.6K 1/4W	FTP=10mm	4	R80、R84、R87、R111	
8	carbon film resistor	10K 1/4W	FTP=10mm	13	R37、R39、R42、R57、R58、R65、R66、R70、R71、R68、R69、R117、R54	
9	carbon film resistor	22K 1/4W	FTP=10mm	12	R34、R35、R36、R38、R40、R41、R102、R103、R104、R105、R106、R107	
10	carbon film resistor	47K 1/4W	FTP=10mm	42	R15、R16、R17、R18、R19、R20、R21、R22、R23、R24、R25、R26、R27、R28、R43、R44、R49、R50、R51、R52、R53、R54、R72、R73、R74、R75、R78、R82、R83、R86、R89、R90、R91、R92、R94、R95、R96、R99、R110、R116、R114、R118	
11	carbon film resistor	47K 1/4W		3	R74、R95、R96、	
12	carbon film resistor	56K 1/4W	FTP=10mm	2	R97、R98	
13	carbon film resistor	100K 1/4W	FTP=10mm	16	R30、R31、R32、R33、R56、R59、R60、R61、R62、R63、R64、R67、R109、	
14	jumper wire	5mm		12	J15、J45、J46、J52、J53、J56、J57、J59、J62、J65、J72、J80	
15	jumper wire	7.5mm		26	J6、J12、J16、J17、J18、J22、J23、J27、J30、J32、J33、J37、J38、J44、J47、J48、J54、J55、J58、J67、J68、J69、J74	
16	jumper wire	10mm		24	J2、J11、J13、J14、J20、J24、J25、J26、J28、J31、J35、J36、J37、J42、J49、J50、J51、J55、J61、J63、J66、J71、J78	
17	jumper wire	12mm		13	J1、J3、J4、J8、J9、J19、J20、J21、J29、J34、J39、J40、J43	
18	jumper wire	15mm		3	J10、J41、J60	
19	jumper wire	17.5mm		1	J7	
20	elect.cap.	1UF/50V	FTP=2.5mm	2	C46、C48	
21	elect.cap.	4.7UF/50V	FTP=2.5mm	2	C47、C49	
22	elect.cap.	10UF/50V	FTP=2.5mm	27	C1、C2、C6、C7、C10、C11、C12、C13、C14、C15、C16、C28、C29、C30、C31、C32、C33、C34、C39、C40、C54、C58、C59、C60、C61、C64、C65	

23	elect.cap.	22UF/16V	FTP=2.5mm	1	C57	
24	elect.cap.	47UF/16V	FTP=2.5mm	4	C3、C17、C21、C37	
25	terylene cap.	103J/50V	FTP=5mm	3	C19、C25、C55	
26	terylene cap.	153J/50V	FTP=5mm	2	C20、C26	
27	terylene cap.	223J/50V	FTP=5mm	1	C58	
28	terylene cap.	104J/50V	FTP2.5mm	8	C18、C23、C24、C38、C50、C53、C62	
29	terylene cap.	334J/50V	FTP=5mm	2	C22、C27	
30	ceramic cap.	101/50V	FTP2.5mm	13	C4、C5、C8、C9、C35、C36、C41、C42、C43、C44、C45、C66、C67	
31	ceramic cap.	33P/50V	FTP2.5mm	2	C51、C52	
35	inductance	1 μ H	FTP=10mm	1	L1	
36	integrate circuit	HCF4051BF	DIP16	3	IC1、IC7、IC11	
37	integrate circuit	HCF4053BF	DIP16	1	IC2	
38	integrate circuit	TL084	DIP14	2	IC3、IC5	
39	integrate circuit	JRC4558	DIP8	2	IC4、IC6	
40	integrate circuit	HA17324	DIP14	1	IC10	
41	integrate circuit	HA17358	DIP8	1	IC12	
42	integrate circuit	24C02	DIP8	1	IC9	
43	integrate circuit	AT89S52	DIP40	1	IC13	
44	integrate circuit	M62446AFP	SMD	1	IC8	
45	transistor	9014		1	Q1	
46	transistor	9015		2	Q2、Q4	
47	transistor	9013		1	Q3	
48	diode	IN4148		5	D6、D7、D8、D9、D10	
49	zenzer diode	7.5V 1/2W		2	ZD1、ZD2	
50	zenzer diode	5.1V 1/2W		1	ZD3	
51	neilsbed	2P 2.5space		1	CN7B	
52	neilsbed	5P 2.5space		1	CN13B	
53	neilsbed	8P 2.5space		1	CN12B	
54	AV sole-core outlet	AV4-8.4-13	white-red	2		
55	AV sole-core outlet	AV6-8.4-13B	yellow-white-red	1		
56	IC bed		DIP40	1	IC13	
57	voltaic wire	20# 60mm with auris				
58	lined route	2P2.5 space 360mm		1	CN10B1	
59	flat ribbon wire	3P2.5 space 380mm		2	CN5A,CN1	
60	flat ribbon wire	4P2.5space 140mm		1	CN10B	
61	flat ribbon wire	4P2.5space 180mm		1	CN3A	
62	flat ribbon wire	5P2.5space 210mm		1	CN9A	
63	flat ribbon wire	5P2.5space 300mm		1	CN10A	
64	flat ribbon wire	8P2.5space 160mm		2	CN7,CN10A1	

AV212T display board

no.	description			quantity/ unit	components position no.	additional explanation
	component name	specification	package			
1	carbon film resistor	10Ω 1/4W	FTP=10mm	1	R12	
2	carbon film resistor	100Ω 1/4W	FTP=10mm	2	R1、R2	
3	carbon film resistor	220Ω 1/4W	FTP=10mm	2	R10、R11	
4	carbon film resistor	2.2K 1/4W	FTP=10mm	1	R19	
5	carbon film resistor	10K 1/4W	FTP=10mm	7	R4、R5、R6、R7、R8、R9、R25	
7	elect.cap.	47U/16V	FTP=2.5mm	1	C1	
8	diode	IN4148	FTP=10mm	5	D2、D3、D4、D5并与LED灯上	
9	zenzer diode	7V5 1/2W	FTP=10mm	1	D1	
10	integrate circuit	PT6311	52 feet	1	U2	
11	remote control receiver	HE3380L		1	U1	
12	blue LED		φ3	1	.	
13	jumper wire	FTP=10mm		9	J1、J9、J10、J11、J12、J13、J14、J15	
14	jumper wire	FTP=11mm		7	J2、J3、J4、J5、J6、J7、J8	
15	jumper wire	FTP=15mm		1	J17	
16	vacuum display screen VFD	VFD HJ3005A W		1		
17	touch key-press	KFC-A07-02	12mm*12mm*7mm	14	DELAY、ECHO、AC-3、DVD、VCD、CK、AUX、MIC1、MIC2、SUR、CEN	
18	neilsbed	2P2.5space insert crookedly		1		
19	flat ribbon wire	8P2.5space 180mm		1	CN12A	
20	flat ribbon wire	4P2.5space 200mm		1	CN13A	
21	flat ribbon wire	3P2.5space 100mm		2	CN15A、CN16A	
22	double side rubber cushion	10MM*10MM*5MM	black	2		

AV212T OK board

no.	description			quantity/ unit	components position no.	additional explanation
	component name	specification	package			
1	carbon film resistor	10Ω 1/4W	FTP=10mm	1	R11	
2	carbon film resistor	68Ω 1/4W	FTP=10mm	1	R23	
3	carbon film resistor	470Ω 1/4W	FTP=10mm	4	R22、R32、R33、R37	
4	carbon film resistor	1K 1/4W	FTP=10mm	1	R48	
5	carbon film resistor	1.5K 1/4W	FTP=10mm	3	R18、R20、R35	
6	carbon film resistor	1.8K 1/4W	FTP=10mm	1	R17	
7	carbon film resistor	2.2K 1/4W	FTP=10mm	1	R40	
8	carbon film resistor	4.7K 1/4W	FTP=10mm	2	R24、R34	
9	carbon film resistor	5.6K 1/4W	FTP=10mm	2	R12、R13	
10	carbon film resistor	10K 1/4W	FTP=10mm	17	R5、R6、R7、R8、R9、R10、R14、R15、R16、R19、R21、R26、R27、R39、R44、R50、R51	
11	carbon film resistor	15K 1/4W	FTP=10mm	3	R4、R38、R47	
12	carbon film resistor	22K 1/4W	FTP=10mm	13	R3、R28、R29、R30、R31、R36、R41、R42、R43、R45、R46、R49、R53、	
13	carbon film resistor	47K 1/4W	FTP=10mm	2	R1、R25	
14	carbon film resistor	100K 1/4W	FTP=10mm	2	R2、R52	
15	elect. cap.	2.2UF/50V	FTP=2.5mm	12	C12、C17、C18、C25、C26、C27、C30、C31、C33、C43、C44、C45	
16	elect. cap.	4.7UF/50V	FTP=2.5mm	2	C29、C37	
17	elect. cap.	10UF/50V	FTP=2.5mm	2	C32、C40	
18	elect. cap.	22UF/16V	FTP=2.5mm	1	C20	
19	elect. cap.	47UF/16V	FTP=2.5mm	5	C4、C10、C19、C34、C38	
20	ceramic cap.	561/50V	FTP=2.5mm	2	C5、C8	
21	ceramic cap.	101/50V	FTP=2.5mm	2	C28、C39	
22	ceramic cap.	22P/50V	FTP=2.5mm	2	C36、C41	
23	ceramic cap.	47P50V	FTP=2.5mm	2	C35、C42	
24	CBB cap.	332J/50V	FTP=3.5mm	1	C1	
25	CBB cap.	823J50V	FTP=3.5mm	2	C6、C7	
26	CBB cap.	272J/50V	FTP=3.5mm	2	C21、C22	
27	CBB cap.	562J/50V	FTP=3.5mm	1	C11	
28	CBB cap.	104J50V	FTP=3.5mm	9	C2、C3、C9、C13、C14、C15、C16、C23、C24	
29	integrate circuit	PT2399	DIP16	1	IC1	
30	integrate circuit	PT2313BL	SMD28	1	IC2	
31	integrate circuit	JRC4558	DIP8	2	IC3、IC5	

32	integrate circuit	HCF4052BE	DIP16	1	IC4	
33	transistor	S9014		3	Q1、 Q2、 Q3	
34	zenzer diode	5V1 1/2W	FTP=8mm	1	D1	
35	mic socket	high shape and nine feet	CK3-6.35-206	2	MIC1、 MIC2	
36	neilsbed	8P 2.5 space		1	CN118	
37	neilsbed	5P 2.5 space		1	CN148	
38	neilsbed	3P 2.5space		1	CN1B	
39	neilsbed	3P 2.5space insert crookedly		2	CN15B、 CN16B	
40	jumper wire	15mm		1	J8	
41	jumper wire	10mm		2	J6、 J10	
42	jumper wire	7.5mm		2	J2、 J9	
43	jumper wire	5mm		9	J1、 J3、 J4、 J5、 J7、 J11、 J12、 J13、 J14	
44	AV sole-core outlet		AV-8.4-8	1	SWA1	
45	rotary encoder	EC162102E1B-HA 1-24P5-KQ200B120-N		2	VOL1、 VOL2	
46	switch			1		
47	flat ribbon wire	2P 2.5 space 100mm		1	CN7A	

AV212T power supply board

no.	description			quantity/ unit	components position no.	additional explanation
	component name	specification	package			
1	high voltage AC cap.	0.1 μ f/275V	Ftp=15mm	2	CK1,CK2	
2	high voltage cap.	103/1KV	Ftp=10mm	2	CK4,CK3	
3	flat ribbon wire	2P2.5space 150mm		1	JK7	
4	neilsbed	3P 3.96VH		3	JK2,JK3,JK5	
5	relay	JQX-14F		1	K1	
6	inductance	ϕ 16 filter		1	L1	
7	power supply switch	SW-3-T20		1	SW1	
8	jumper wire	22mm		1	F2	

AV212T amplifier board

no.	description			quantity/ unit	components position no.	additional explanation
	component name	specification	package			
1	carbon film resistor	4.7 Ω 1/4W	FTP=10mm	2	R805、R806	
2	carbon film resistor	10 Ω 1/4W	FTP=10mm	3	R30、R40、R58	
3	carbon film resistor	100 Ω 1/4W	FTP=10mm	14	R24、R32、R36、R44、R51、R60、R71、R72、R87、R88、R73、R74、R78、	
4	carbon film resistor	220 Ω 1/4W	FTP=10mm	3	R31、R41、R59	
5	carbon film resistor	390 Ω 1/4W	FTP=10mm	2	R85、R89	
6	carbon film resistor	560 Ω 1/4W	FTP=10mm	1	R22	
7	carbon film resistor	750 Ω 1/4W	FTP=10mm	2	R107、R109	
8	carbon film resistor	1K1/4W	FTP=10mm	3		
9	carbon film resistor	1.2K 1/4W	FTP=10mm	5	R34、R38、R62、R70、R86	
10	carbon film resistor	1.8K 1/4W	FTP=10mm	1	R801	
11	carbon film resistor	2.2K 1/4W	FTP=10mm	16	R18、R19、R20、R21、R23、R35、R39、R63、R66、R67、R75、R80、R90、R91、R104、R108	
12	carbon film resistor	3.3k 1/4W		3	R33、R37、R61	
13	carbon film resistor	3.9K 1/4W	FTP=10mm	3	R26、R46、R52	
14	carbon film resistor	4.7K 1/4W	FTP=10mm	5	R29、R42、R50、R84、R103	
15	carbon film resistor	10K 1/4W	FTP=10mm	2	R77、R82	
16	carbon film resistor	22K 1/4W	FTP=10mm	5	R43、R57、R64、R83、R106	
17	carbon film resistor	27K 1/4W	FTP=10mm	3	R27、R47、R54	
18	carbon film resistor	33K 1/4W	FTP=10mm	7	R28、R49、R56、R68、R76、R81、R92	
19	carbon film resistor	47K 1/4W	FTP=10mm	4	R48、R55、R105、R802	
20	carbon film resistor	56K 1/4W	FTP=10mm	5	R6、R7、R8、R9、R10	
21	carbon film resistor	1M 1/4W	FTP=10mm	1	R11	
22	carbon film resistor	220 Ω 1/2W	FTP=12.5mm	2	R69、R85	
23	carbon film resistor	10 Ω /2W resistor	FTP=18mm H=7.5mm	2	R4、R5	
24	carbon film resistor	10 Ω /0.5W resistor	FTP=15mm	3	R1、R2、R3	

25	carbon film resistor	100 Ω /1W resistor	FTP=15mm	4	R14、R15、R16、R804	
26	carbon film resistor	75 Ω /1W resistor	FTP=15mm	1	R17	
27	metal film resistor	0.47 Ω /3W resistor	FTP=18mm H=7.5mm	6	R93、R94、R95、R96、R97、R98	
28	cement resistor	39 Ω /5W		1	R01	
29	cement resistor	0.25 Ω /5W		4	R99、R100、R101、R102、	
30	adjustable resistor	501	PA0630-HA 1-B501HR	2	VR1、VR2	
31	neilsbed	TCJ2		2	CN2、CN1	
32	neilsbed	3P 3.96VH		1	J801	
33	neilsbed	2P 2.5 space		1	J802	
34	neilsbed	3P 2.5 space		1	CN5B	
35	neilsbed	4P 2.5space		1	CN3B	
36	neilsbed	8P 2.5space		1	CN4B	
37	inductance loop	10*14T		2	L1、L2	
38	fuse box	metal		2	FUSE1 FUSE2	
39	fuse	8A	φ 5*20mm	2		
40	KBU808G bridge rectifier	KBU808G		1		
41	output jack	WP6-10A		1		black bottom red top
42	output jack	WP4-10A		1		black bottom red top
43	diode	IN4148	FTP=10mm	18	D4、D5、D6、D7、D8、D15、D16、 D17、D18、D19、D20、D21、D22、D23 、D24、D28、D29、D30	
44	diode	IN4004	FTP=10mm	10	D1、D2、D3、D25、D26、D801、D802 、D803、D804、D810	
45	transistor	2N5401		12	Q6、Q9、Q12、Q13、Q21、Q22、Q23 、Q29、Q30、Q39、Q41、Q42	
46	transistor	2N5551		26	Q5、Q7、Q8、Q10、Q11、Q14、Q15、 Q17、Q19、Q20、Q24、Q25、Q26、Q27 、Q28、Q30、Q31、Q32、Q33、Q34、 Q35、Q36、Q37、Q38、Q41、Q42、	
47	transistor	2N5551		2	Q57、Q58	
48	transistor	9014		3	Q1、Q2、Q3	
49	transistor	9015		2	Q4、Q801	
50	transistor	8050		1	Q802	
51	transistor	669A		2	Q43、Q46	
52	transistor	649A		2	Q45、Q44	
53	transistor	C2837		2	Q53、Q56	
54	transistor	A1186		2	Q54、Q55	
55	transistor	C4466		3	Q48、Q49、Q52	
56	transistor	A1693		3	Q47、Q50、Q51	
57	ceramic cap.	33P/50V	FTP=2.5mm	4	C56、C59、C62、C63	
58	ceramic cap.	101/50V	FTP=2.5mm	8	C32、C38、C48、C52、C54、C57、C64 、C65	
59	ceramic cap.	471/50V	FTP=2.5mm	1	C67	
60	ceramic cap.	104/50V	FTP=5mm	2	C801、C802	
61	CBB cap.	104J/50V	FTP=3.5mm	1	C69、	
62	CBB cap.	104J/50V	FTP=7.5mm	5	C12、C11、104M、104M、104M	
63	CBB cap.	103J/50V	FTP=3.5mm	1	C16	

64	CBB cap.	332J/50V	FTP=2.5mm	3	C41、C45、C53
65	elect. cap.	470 μ F/16V	FTP=3.5mm ϕ 8mm	3	C25、C26、C27
66	elect. cap.	220 μ F/25V	FTP=3.5mm ϕ 8mm	6	C13、C14、C15、C58、C66、C75
67	elect. cap.	220 μ F/35V	FTP=2.5mm ϕ 8mm	1	C7
68	elect. cap.	470 μ F/50V	FTP=5mm ϕ 13mm	2	C5、C6
69	elect. cap.	6800 μ F/50V	FTP=10mm ϕ 30mm	2	C1、C2
70	elect. cap.	2200 μ F/25V	FTP=7.5mm ϕ 16mm	2	CD801、CD802
71	elect. cap.	100 μ F/16V	FTP=2.5mm ϕ 7mm	3	C23、C24、C74
72	elect. cap.	100 μ F/35V	FTP=3.5mm ϕ 8mm	1	C28
73	elect. cap.	47 μ F/16V	FTP=2.5mm ϕ 5mm	5	C17、C18、C19、C20、C22
74	elect. cap.	22 μ F/35V	FTP=2.5mm ϕ 5mm	1	C21
75	elect. cap.	100 μ F/25V	FTP=2.5mm ϕ 6mm	3	C34、C37、C49
76	elect. cap.	47 μ F/50V	FTP=2.5mm ϕ 6mm	9	C30、C31、C35、C36、C40、C42、C43、C44、C50
77	elect. cap.	2.2 μ F/50V	FTP=2.5mm ϕ 5mm	5	C29、C46、C47、C60、C61
78	elect. cap.	4.7 μ F/50V	FTP=2.5mm ϕ 5mm	4	C3、C4、C55、C68
79	elect. cap.	1 μ F/50V	FTP=2.5mm ϕ 5mm	3	C33、C39、C51
80	36V zener diode	36V 1/2W	FTP=10mm	2	D31、D32
81	12V zenzer diode	12V 1/2W	FTP=10mm	3	D10、D11、D14
82	5.6V zenzer diode	5.6V 1/2W	FTP=10mm	2	D9、D12
83	30V zener diode	30V 1/2W	FTP=10mm	1	D13
84	jumper wire	10mm		34	J1、J34、J33、J19、J41、J32、J94、J95、J22、J31、J99、J4、J5、J61、J35、J44、J47、J50、J45、J51、J52、J54、J55、J58、J60、J62、J72、J73、J68、J85、J81、J83、J84、J56
85	jumper wire	12mm		18	J6、J7、J8、J9、J10、J11、J12、J29、J24、J25、J26、J20、J21、J69、J71、J77、J78、J85
86	jumper wire	15mm		23	J80、J93、J13、J14、J15、J16、J17、J63、J49、J48、J91、J53、J101、J102、J86、J74、J75、J100、J42、J89、J92、J30
87	jumper wire	20mm		7	J27、J28、J97、J98、J70、J38、J95
88	jumper wire	7.5mm		3	J64、J04、J87
89	jumper wire	5mm		11	J43、J57、J79、J82、J88、J36、J37、J40、J02、J76、J01
90	relay	12V Dual units	8 feet	1	RELAY3
91	relay	12V triple units	11 feet	1	RELAY4

AV212T configuration

no.	description			quantity/ unit	components position no.	additional explanation
	component name	specification	package			
1	plane type bracket	Φ 4H14mm		4	fixed main board	
2	plastic pillar	6*2.5*10		6	fixed mic board .CPU board	
3	cable tie	3*80mm		10	fixed flat ribbon wire	black
4	plastic pillar	6*2.5*20		4	fixed power supply board	
5	plastic pillar	6*3.5*20		8	fixed sreen board	
6	plastic pillar	6*3.5*30		1	fixed mic seat	
7	red insulated pa per cushion	Φ 3		12	for a djusting the screws on the panel	
8	plan washer	Φ 3		11	fixed power tube, bridge rectifier	
9	spring wa sher	Φ 3		11	fixed power tube, bridge rectifier	
10	nut	Φ 3		1	fixed bridge rectifier	
11	plan washer	Φ 4		2	fixed transformer	
12	spring wa sher	Φ 4		2	fixed transformer	
13	nut	Φ 4		2	fixed transformer	
14	triangle tapping screw	BTB3*12HNI		10	fixed power tube	
15	triangle tapping screw	BTB3*6HNI		23	fixed CPU board, power supply board,mic board,radiator	
16	triangle tapping screw	BTB3*10HNI		11	fixed input board,output board,receiver	
17	triangle thin tooth like screw	STB4*8HNI		6	fixed transformer, feet at the bottom of the machine	
18	triangle thin tooth like screw	STB3*6HNI		36	fixed support bar,panel,rear panel,power supply switch,step select board	
19	triangle thin tooth like screw	STB4*8HAU		4	fixed cover	golden
20	triangle thin tooth like screw	STB3*8HAU		3	fixed cover	golden
21	screw with washer	MPW3*14HNI		1	fixed bridge rectifier	
22	screw with washer	MPW3*4HNI		12	fixed side bar,lens	
23	sink head沉头机丝	MF3*6ZN		2	fixed big support bar	white
24	normal screw	MB3*24NI		8	fixed sreen board	
25	normal screw	MB3*33NI		1	fixed mic socket bracket	
26	panel			1		
27	main volume knob	50*20		1		rachis
28	tuner knob	41.3*20		1		rachis
29	power switch cap			1		
30	touch power switch			14		
31	lens	192*41*2		1	stick plastic pillar need process	blue
32	power switch decorate chart			1		
33	panel side bar			2		
34	feet at the bottom of the machine			4		
35	machine bottom			1		
36	rear board			1		

37	long support bar(left)			1		
38	long support bar(right)			1		
39	short support bar			2		
40	power switch bracket			1		
41	mic socket fixed bar			1		
42	transformer cover			1		
43	L type small bracket			2	step select board	
44	round transformer	212T		1 set	including the screws	
45	square transformer			1		
46	BBK metal brand	BBK		1		
47	big radiator	AV212T		1		
48	bridge rectifier radiator					
49	silicon grease			10g		
50	card along with the machine			1		
51	red glue			suitable	for fixing the named parts	
52	high pressure protect cover			1	install on the switch	black
53	single side sponge glue	30*20*10		1	install on the ok board	black
54	receiver	T-939SH1		1		
55	double side sponge glue	20*20*5		3		
56	outer water-proof plastic bag (big)	special use		1pcs		
57	inside water-proof plastic bag (small)	special use		1pcs		drill small ventilate holes
58	accessories plastic bag (small)			1pcs		drill small ventilate holes
59	poly			1 group	four pieces	
60	carton box			1pcs		
61	remote control plastic bag			1pcs		equipped by the remote control factory
62	transparent sealed glue	1*3cm		1 group		
63	transparent sealed glue	6*124cm		1 group		
64	serial label	special use		3 pieces		
65	bar code	special use		1 piece		
66	servicing card	AV210T		1 copy		
67	manual	AV211T		1 copy		
68	remote controller	AV212T		1 pcs		
69	No.7th battery	AAA R03P		2 parts		
70	AM antenna			1 piece		
71	FM antenna			1 piece		

IBIBK

DIGITAL SOUND FIELD PROCESSING RECEIVER AMPLIFIER AV212T

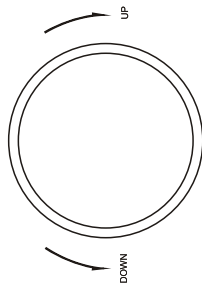

ADJUST

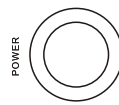

POWER

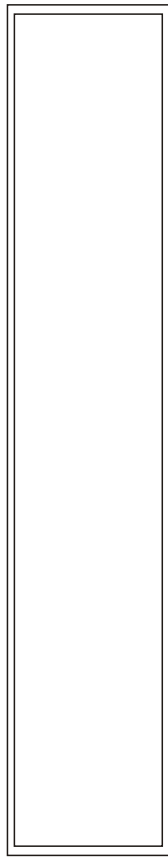

MENU+



AC-3



TUNER



DVD



VCD



CD



AUX



MENU-



FM/AM



SCAN+



SCAN-



MEMORY



A/B/C/D/E



NO. 1-8

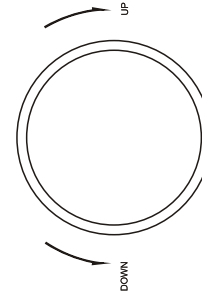

MASTER VOLUME



MC1



MC2

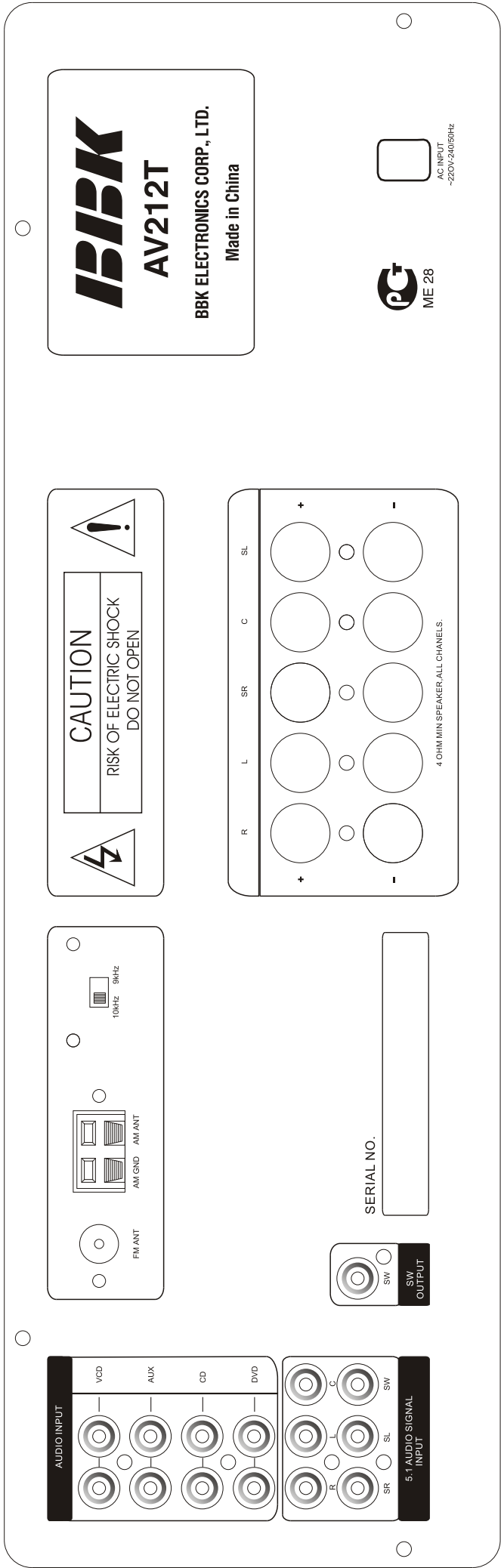

AV212T REAR PANEL

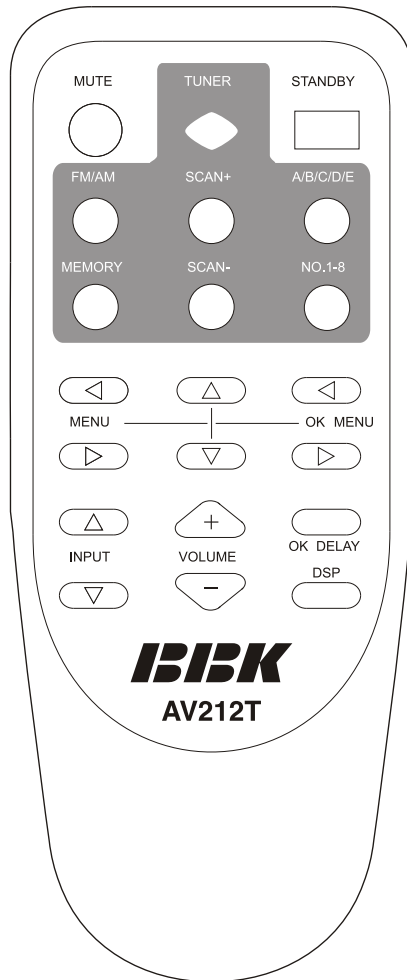

AV212T REMOTE CONTROLLER

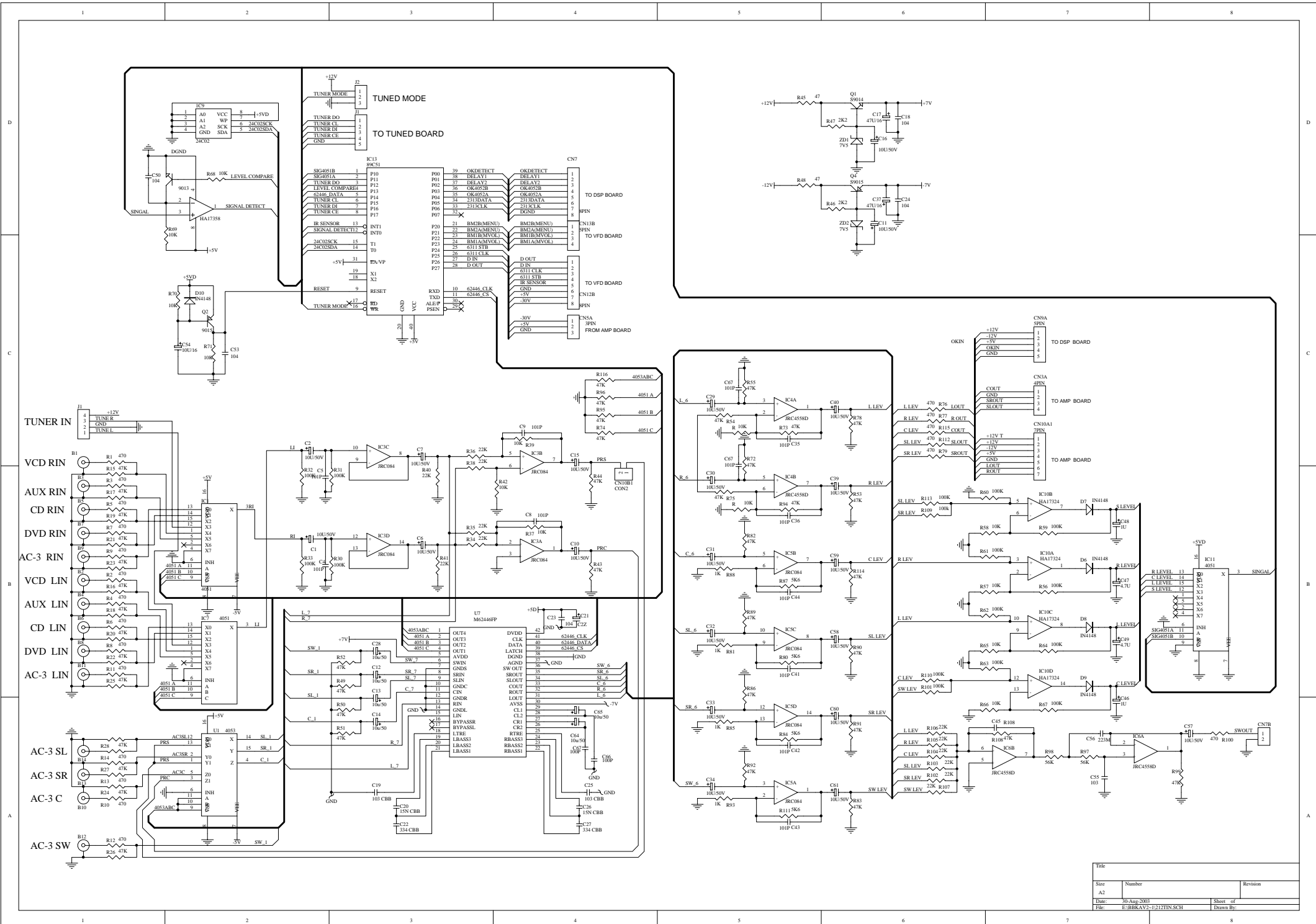

Title		
Size	Number	Revision
A2		
Date:	30 Aug 2003	Sheet of
File: E:\BOKAV\2-12121\IN.SCH		Drawn By:

OK SCH

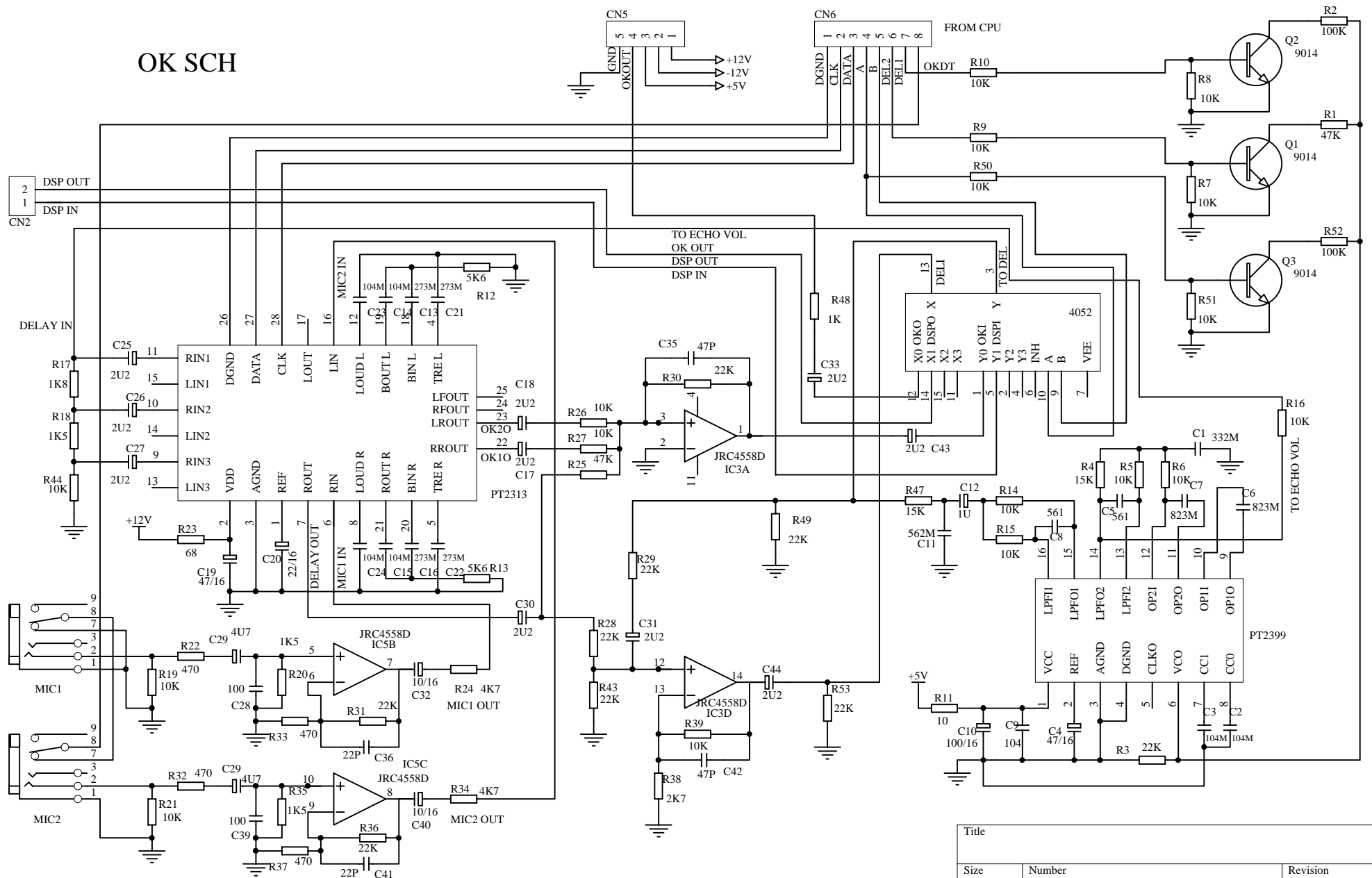

Title		
Size	Number	Revision
A4	AV212T-OK	
Date:	30-Aug-2003	Sheet of
File:	E:\BBKAV2-1\212TOK.SCH	Drawn By:

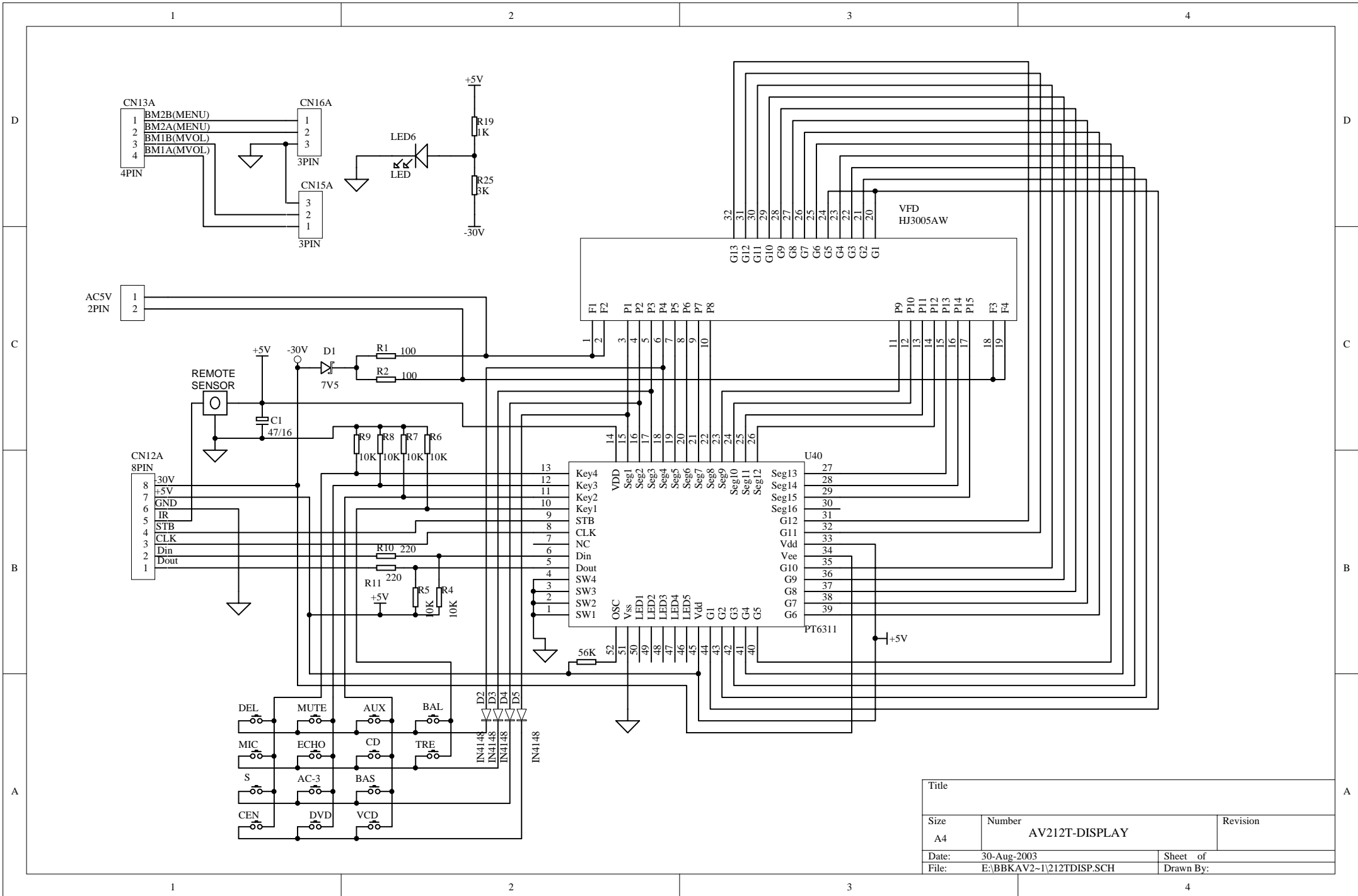

Title		
Size	Number	Revision
A4	AV212T-DISPLAY	
Date:	30-Aug-2003	Sheet of
File:	E:\BBKAV2-1\212TDISP.SCH	Drawn By:

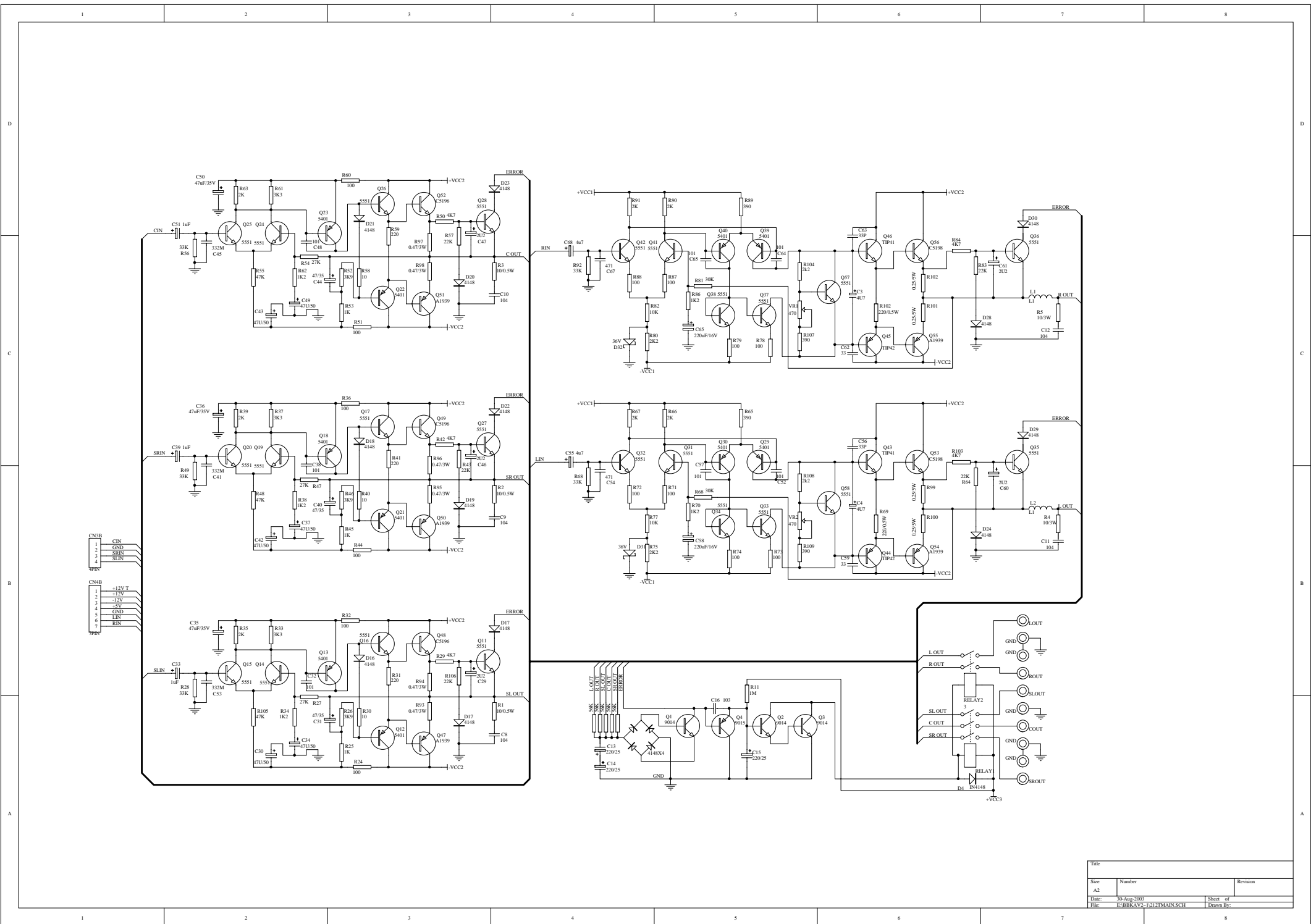

Title		
Size	Number	Revision
A2		
Date:	30 Aug 2003	Sheet of
File:	E:\BRKAV2\1212\MAIN.SCH	Drawn By:

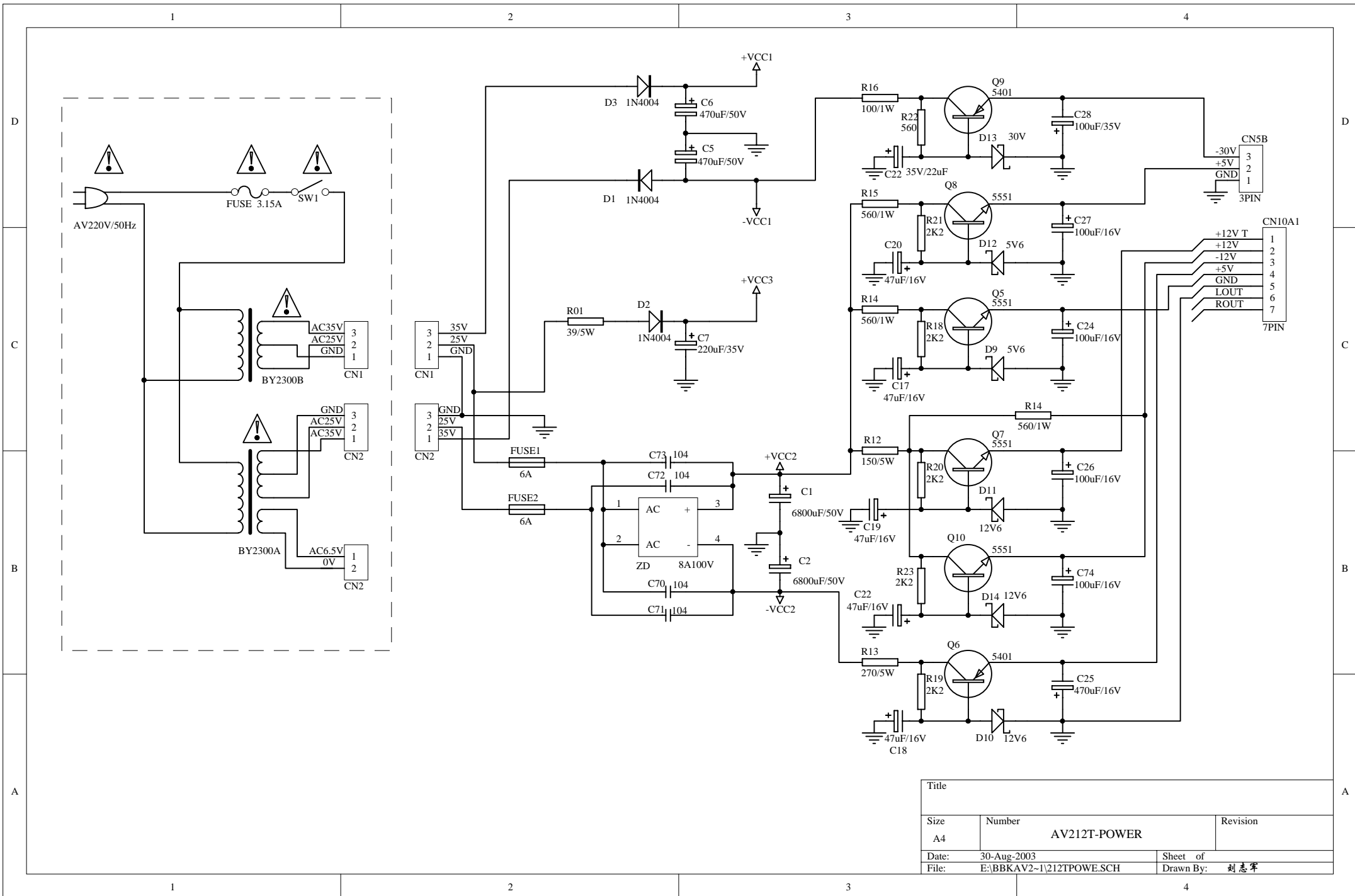

Title		
Size	Number	Revision
A4	AV212T-POWER	
Date:	30-Aug-2003	Sheet of
File:	E:\BBKAV2-1\212TPOWE.SCH	Drawn By: 刘志军

