

AV320T AMPLIFIER.SCH



XP9

1	SWM
2	L1
3	R1
4	C1
5	SL1
6	SR1
7	GND

CON7

1	GND
2	P_RV
3	P_RC
4	P_LRM
5	P_CSM

CON5

XS7

1	SWM
2	R10
3	P_RC
4	Over

CON4

XP6

1	+12V
2	DGND
3	DGND
4	-12V

CON4

XS8

1	L2
2	R2
3	C2
4	SL2
5	SR2
6	Vc+
7	GND
8	Vc-
9	Vc-

CON9

XS5

1	
2	
3	

CON3

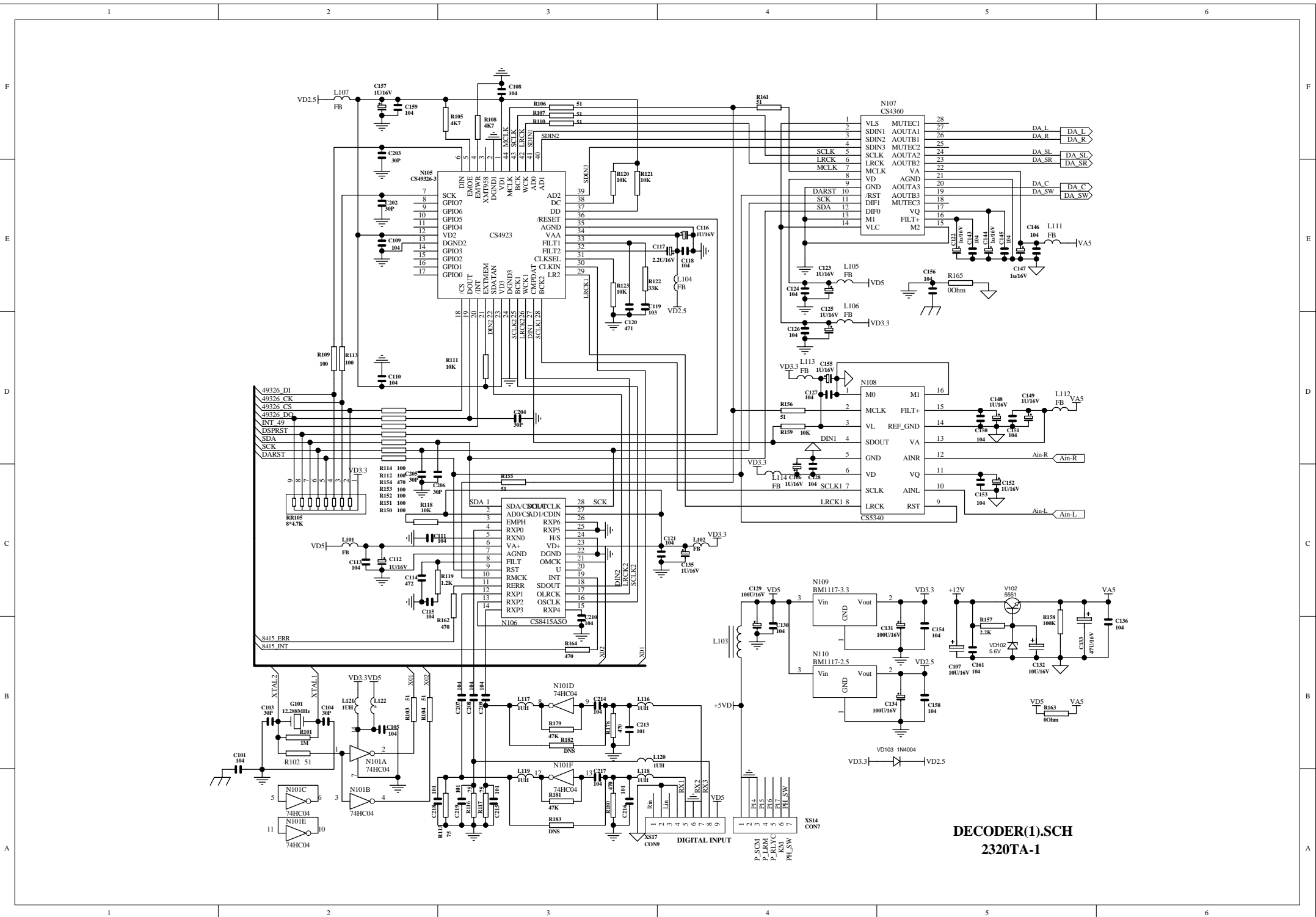

**DECODER(1).SCH**  
**2320TA-1**

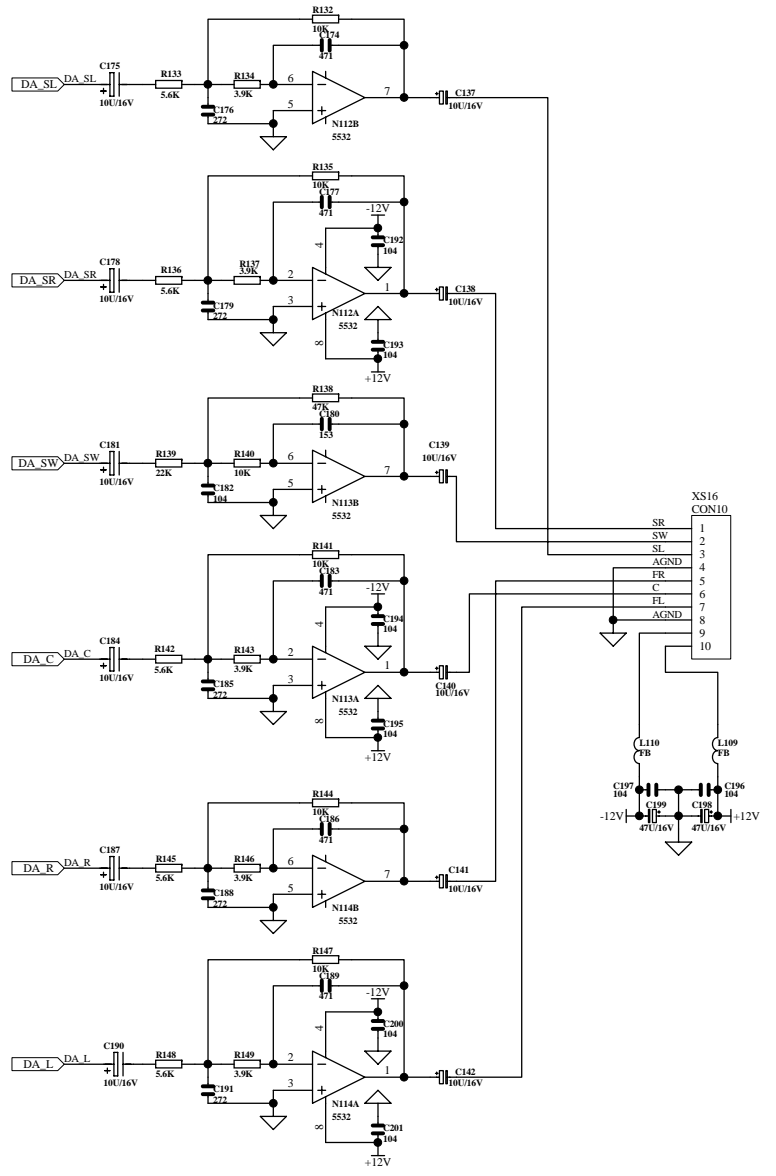
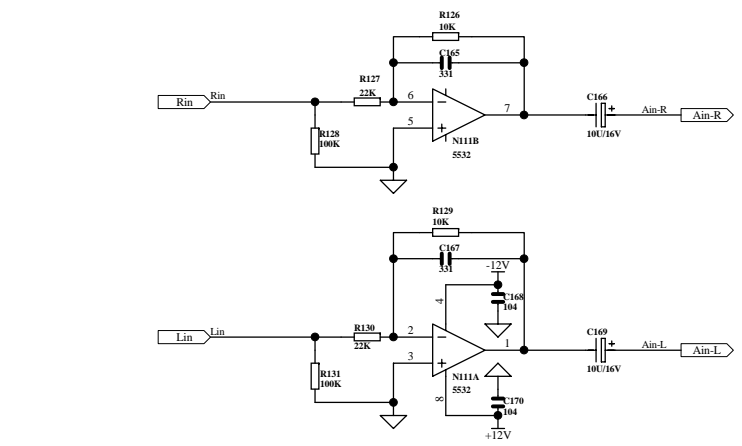
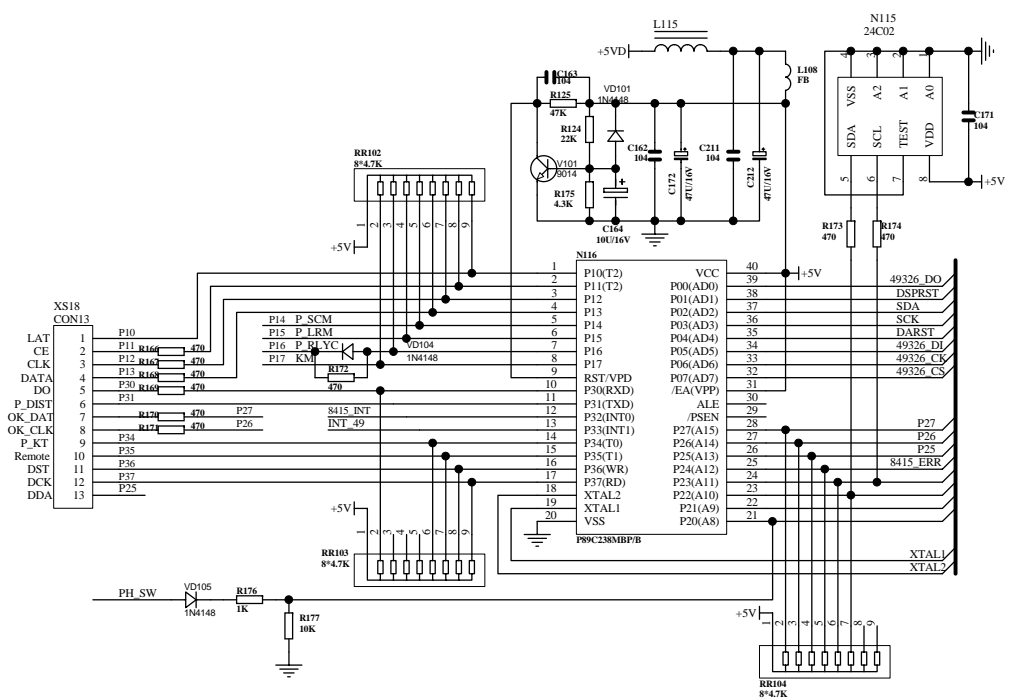

DECODER(2) SCH  
2320TB-1

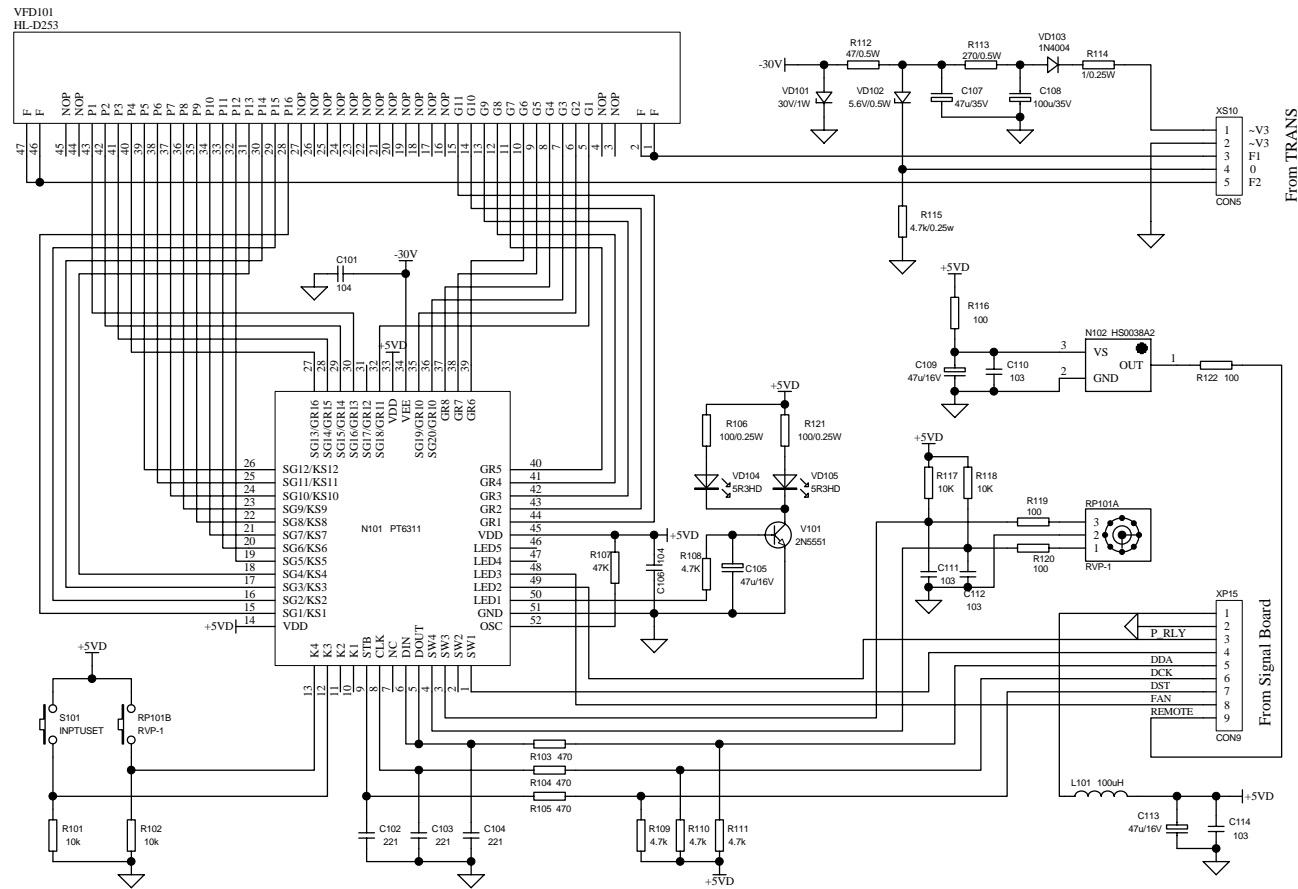

AV320T FRONT PANEL.SCH

## **Principle and Maintenance Brochure for AV320T (RU)**

### Table of Contents

#### **Chapter One: Product Introduction**

#### Chapter Two: Working Principle

- I. Components of the Complete-machine
- II. Signal Processing Board
- III. Decoder Board
- IV. Panel
- V. Power Board
- VI. Loudspeaker Board & Protection circuit

#### Chapter Three: Appendix

#### Appendix I. Connection Diagram and Principle Diagram

#### Appendix II. Introduction to Major IC Pin Function

#### Chapter One: Product Introduction

AV320T (RU), the recently launched power amplifier of superior quality, has successfully employed the DTS/AC-3 digital decoding functions to ensure high-quality sound effects, which eliminates the sound distortion and noise in audio signal processing. AV320T (RU) is characterized by:

1. Precise Operating Panel Interface: The complete-machine assembles a single power switch button, menu button and a big knob in the operating board, which are easy to operate.
2. DTS/AC-3 Decoding Function
3. with Fiber, Coaxial Signal Decoding Function
4. Built-in 5-Channel amplifier was adopted to accord with AC-3/DTS and stereo music playback. Strong in power, the main channel is 100w and the center& surround channel is 22w.
5. Equipped with 6-channel volume control and independent power control, and 7-segment electric equilibrium
6. Equipped with multi-electric equilibrium mode to serve music of different styles.
7. Digital sound field time-lagging function
8. with built-in radio function
9. Qualified with over-power and over-pressure intelligent protection function
10. Karaoke function and earphone output

#### **Chapter Two Working Principle**

#### I. Components of the Complete-machine

AV320T (RU) consists of the following seven components:

1. Signal processing board: for signal gating, pre-amplifying and the pre-processing of Karaoke signals
2. Decoding board: in charge of the control to the whole power amplifier and the digital signal process;
3. Control Board: VFD Display, the menu button and main volume control
4. Power board and protection circuit: to supply the working voltage needed to unit circuit and carry out the protection function to the whole power amplifier;
5. Amplifier board: to amplify the power of the 5.1-channel signal and simulated signal;

6. Earphone board: to amplify the karaoke input and earphone output signal.

## II. Signal Processing Board

1. The six input styles of AV320T (RU): Fiber input, coaxial input, CD, DVD, 5.1-channel and radio input.

The digital signal of fiber and coaxial input is processed in decoding board through lines. The simulate input option of AV320T (RU) is realized through the two electric switches, the truth table is as follows:

CD4052 Truth Table

	CD	Radio	DVD	
A	1	0	1	
B	1	1	0	

**The three simulated input status :** AV320T (RU) has the three simulated input states: radio, CD, DVD, which are controlled through signal 4052-A and 4052-B respectively (refer to the truth table). The gated signal is output from Pin 3 and Pin 13 of N101; then through N111 CD 4052, the main channel signals of the right and left are output through Pin1 and Pin12; the signal is finally processed in the decoding board.

The simulated signal input in 5.1 state: The 5.1 simulated signal input of AV320T (RU) controls is gated by the two IC CD 4053s, Pin 9, Pin 10 and Pin 11 of which is controlled by the signal 5.1CH output from Pin 4 of M62446. When signal 5.1CH becomes high level, the strobe becomes the State 5.1 simulated signal input, under which the digital sound field disappears and all the signals becomes direct. When signal 5.1 CH becomes low level, the strobe becomes the signal composed through decoding.

The shift control of direct mode and digital sound field mode: AV320T (RU) has direct mode and digital sound field mode, its strobe input is controlled by N111 CD 4052 and N102 CD 4053. When signal 4053-INT becomes high level, the IC is out of working status as it is connected to the emarginated terminal of N102, thus the main channel signal is output through Pin 6 and Pin 11 of N111, and directly transmitted to the hi-fi music signal processed by M62446. When 4053-INT becomes low level, the main channel signal is transmitted to decoding board for digital sound process, while N102 is still under working status.

2. The signal process of Karaoke

After the signal of Karaoke transmitted from M-board is amplified in coupling amplifier, it is directly transmitted to Volume and Key Control IC PT 2315 for processing, after the reverberation delay is adjusted in PT2399, it is transmitted through band pass filter to loudspeaker for small-signal amplifying. As PT 2315 is controlled by CPU, the user may adjust it through the remote controller as they like.

While the other signal, after being amplified and rectified, is used to control the switch triode V201 9014 and in turn to control the high level and low level of the Test Signal P-KT to test Karaoke signals. When the input Karaoke signal is strong enough to lead the direct current rectified to triode 9014, and to lower the P-KT signal, which indicates the input of Karaoke signals. When the system is unable to detect signals in a certain period of time, the system will automatically becomes soundless in the section of Karaoke and prevent the outside noise from affecting the audio effect.

3. The switch-on of fan

When the amplifier is loaded, given that the power increases and the temperature raises fast, the

power amplifier equipped with fan for heat radiating. When volume is bigger than 45 DB, the signal of fan becomes high level, V103 and V105 becomes electrified and forms a circuit to switch on the fan. But when the earphone is loaded, the control line PH-SW becomes high level, then V104 becomes electrified and lowers the signal of the fan, consequently, no matter how high the system volume is, the fan will not be switched on.

### **III. Decoding Board**

The main components of the decoding board are listed as follows:

CPU: the controlling core of the power amplifier

IC 493264: the high-performance digital audio decoder, including DOLBY decoding, DTS decoding and DSP processing.

IC 8415: Serial audio digital signal receiver

IC CS5340: 2-channel A/D shift

IC CS 4360: 6-channel A/D shift

IC 24C02: status saving

IC 74HC04: multiplex (MPX) inverter

IC BM1117-3.3: 3.3V stable voltage IC supplying power to CS8415, CS4923

### **Working Principle**

After the fiber and coaxial signal go through the inductance filter and capacitance filter, it will be inverted in the inverter and then transmitted to Pin 4, Pin12 and Pin 14 of the serial audio digital signal receiver IC CS8415, through this IC, the serial audio digital signal is transformed into PCM signal and output through Pin 16(sampling rate signal), Pin 17(main channel clock signal) and Pin 18(audio data signal) to Pin 25(sampling rate control signal), Pin 26(clock signal) and Pin 22(PCM data input interface 1) of the digital audio decoder IC CS4923, and the data will then be processed.

After the signal of the simulated right and left channels signal is transmitted through Line XS17 to decoding board for small-signal pre-processing , it will be transmitted to Pin 10 and Pin 12 of IC CS5340 for A/D shift, turning the simulated audio signal into PCM signal, and then transmitted from Pin 4(audio PCM signal), Pin 17(sampling rate signal) and Pin18(clock signal) of CS5340 to Pin 27, 28 and 29 of CS 4923, i.e. it is transmitted to the other PCM interface of CS4923 for data processing.

In consequence, the digital sound field processing of simulated signal and the coaxial and fiber processing are relatively independent, if either of the processing does not work, the problem will more probably occurs before CS4923.

CS4923 has the function of digital sound field processing, within which DSP processing, PROH processing and DOBLY/AC-3 processing takes place through the CPU.

The audio PCM signal processed by CS 4923 is transmitted to CS4360 for D/A shift, turning the PCM signal back to the 6-channel simulated signal, then it filters the noise beyond the frequency range in the band pass filter, finally it is transmitted to input gating section for choice input.

As the core of the whole machine, CPU is of vital importance. Through it, all control signals controls the actions and continuously check different signals and the user's orders to control the action of every part of the machine. In case the CPU is of bad quality, the whole machine will not be able to work properly.

In addition, this machine does not have the automatic searching function; instead, it will

automatically save and memorize the last working status and the first working status after the machine being switching on.

This machine is qualified with radio function, offering the users a variety of function choices. It receives the frequency signal through the radio head controlled directly by CPU and outputs the signal after being amplified through power amplifier. The radio head and LM62446 share the clock and the data line, while the other control lines are directly connected to CPU, and the L and R signals processed by the radio head are directly transmitted to the pre-amplifier for strobe input.

#### IV. Control Board

The control board mainly consists of VFD display, driver IC PT6311 and remote receiver HSO038A2 and signal lamp video circuit. It mainly assumes the task of man-computer dialogue and working status revelation.

Diagram:

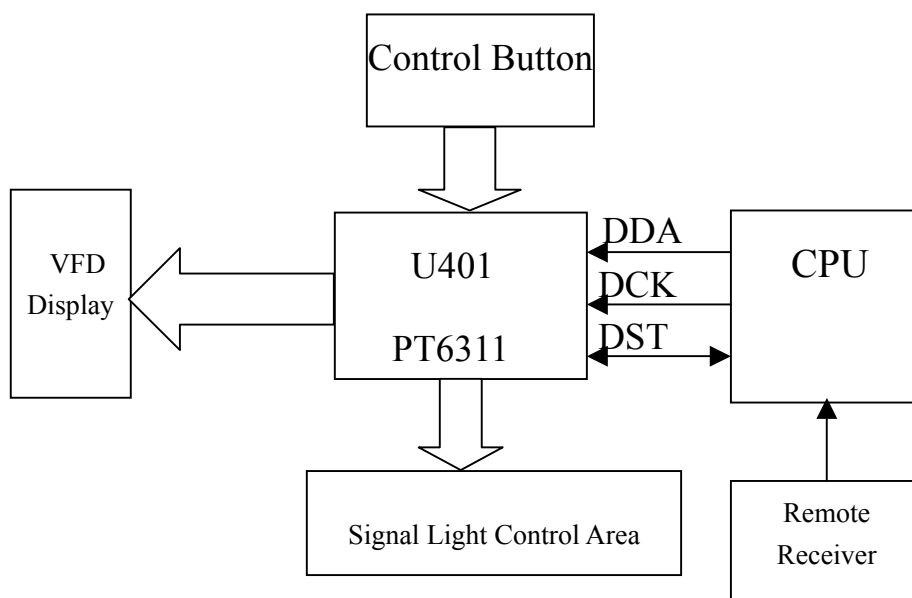

Under the control of CPU: the DST status, DCK clock and DDA data control PT6311 to show the working status of the whole machine, in receiving the user's orders, they control the circus of the whole machine, enabling the whole machine to work in a designated status.

When the users operate the board buttons, the order of control is transmitted to PT6311 through the keyboard scanning circuit; while PT6311 is driven through encoding in the inner, and outputs the control data to CPU, which in turn control the circuit and VFD through PT6311.

VFD101 is a vacuum fluorescence display screen, it is highly characterized by high light. Its working principle is similar with the picture tube of televisions. Pin 1, 2, 46 and 47 supply power for the filament of the bulb; CPU ultimately controls SEG polar through its control over PT6311, enabling the characters appropriate with the working status to be revealed on the screen.

The remote receiving circuit is mainly composed by remote control receiver HSO038A2, among which Pin 1 is connected to the ground, Pin 2 supplies the power and Pin 3 outputs the received signals and leads them to CPU to control the appropriate circuit.

#### V. Power Board

The function of power board is to supply a variety of working voltages needed by the unit circuit



of the whole machine. AV320 (RU) applies a annular transformer of 335W. The Central Channel and surround channel of AV320 (RU) adopt LM1875 and LM4731 respectively, and LM4731 is amplified IC powered by dual channels, which adopts independent positive power source to supply electricity, enabling a high separation between the two surrounding channels; Compared with the previous products, it adds  $\pm VSS$  power supply, which is illustrated as follows:

1. The two alternating currents of 38V firstly transmitted from the transformer are filtered and rectified through the four IN5404 and the two electrolysis condenser 15000uF/68V, and then the  $\pm 53V$  power is obtained for power supply of the right and left channels.

2. The two alternating currents of 21V secondly transmitted from the transformer are filtered and rectified through the four IN5404 and the two electrolysis condenser 47000uF/35V, and then the  $\pm 28V$  power is obtained for power supply of Channel SL/SR/C. In addition, the other ICs and collinear amplifier supply its IC with powers obtained through regulation from the regulator tube L7812 and L7912.

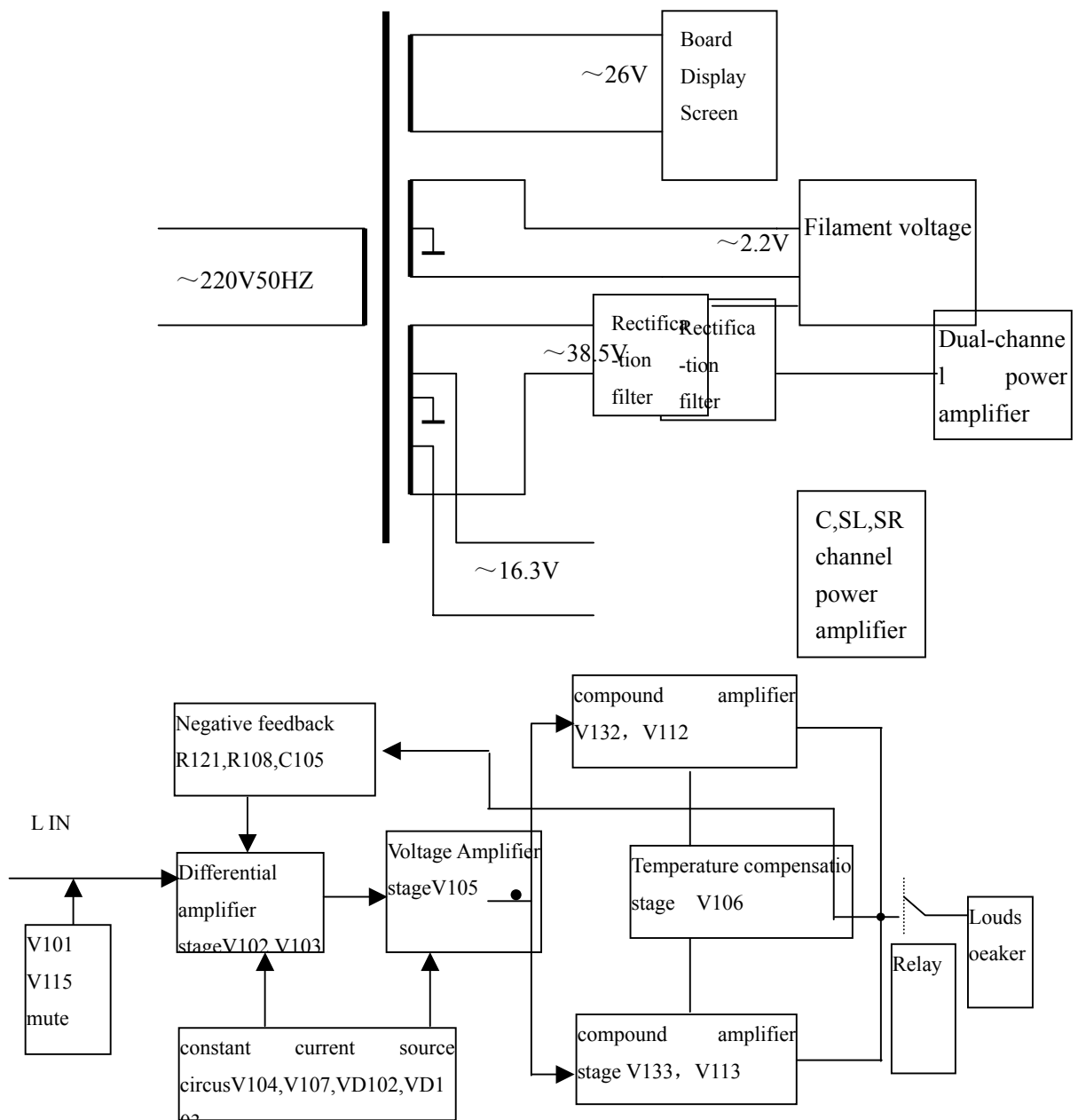

## V. Loudspeaker Board and Protection circuit

I. Channel L and R Power Amplifying circuit: The channel L and R main loudspeaker circuit of AV320 (RU) consists of discrete components, which is shown as follows: ( e.g: Channel L)

The channel signal is transmitted through coupler R101、R103、C101 to Polar B of differential amplifier stage V102, V102 and V103 compose the differential amplifier circuit with one-end input and output. Sound signals are transmitted from Polar C of V102 to Polar B of voltage amplifier V105, after the voltage is amplified; it is output to compound power amplifier. V104, V107, VD102 and VD103 compose constant current source circuit, among which VD102 and VD103 supply stable base current to V104 and V107. The emitter resistance of V104 decides the working current of differential amplifier stage, while the emitter resistance of V107 decides the working current of voltage amplifier stage. V132 and V112 compose composite tube amplifier, ensuring that the lowest-level energy of the power amplifier have sound current amplifying capacity, and they composes positive 1/2 duty cycle amplifying. V133 and V113 compose the negative duty cycle amplifying, the circuit construction is completely same with that of the upper tube. Temperature compensation tube V106 has two functions in the circuit: first, it is the base bias of the upper and lower tubes, its working status decides the stable working current of the compound amplifier stage, i.e. by adjusting the electric conduction degree of V106, we can set the static working point of compound amplifier stage , while the common method is to change the base resistance of V107; it also automatically adjust the working status of the compound amplifier stage after the temperature rises. The adjustment process is specified as follows:

Total current of output stage= working current +leakage current

When the temperature rises, the leakage current increases and leads to the floating of static working point, which is harmful.

Meanwhile, the leakage current of V106 increases,  $U_{ce}$  decreases and in turn to decrease the bias-current of output stage, changing the working status and decreasing the working current of back-end amplifier, as a result, realizes temperature compensation.

In the power amplifying circuit of AV320 (RU) , the negative feedback of voltage is induced, which is composed of R121, R109 and C105, and is used to stabilize the static working point of differentiate stage. AV3120 (RU) adopts direct output method, R111 and C116 connected with the output end form Roberl Network which prevents the high-frequency self-oscillation resulted from alternating current inductance in the loudspeaker voice coil.

2. Working principle of Channel R: (refer to the working principle of Channel L)

3.Mute circuit: When you press the button “Mute”, the remote control receiver transforms the signal into a signal of “mute” to CPU, form which Pin 35 and 36 send out an order of “high level mute” electrifying V115, V101 and V116, the left and right channels short-circuited the signal to the ground, consequently complete the function of mute control.

The Power Amplifying circuit of C, SR and SI: Compared with the machine in the past, the three channels of AV320 (RU) adopts the exclusive power amplifier LM4731 and IC LM1875. LM4731 has 15 pins, among which Pin 2, 15 and 4 are its negative and positive power pins respectively, while Pin 7, 8, 12 and 13 are its in-phase input and out-phase input, the fixed output wattage of the IC with such wattage may reach 20 W and makes it possible for becoming automatic mute when the machine is on; while 1875 is a high-performance power amplifying IC with 5 pins, its application circuit is simple and has an output wattage of 5 W in fixed status. Pin 5 and 3 are the power-supplying pins of positive and negative electloudspeaker. Appendix Appendix I.

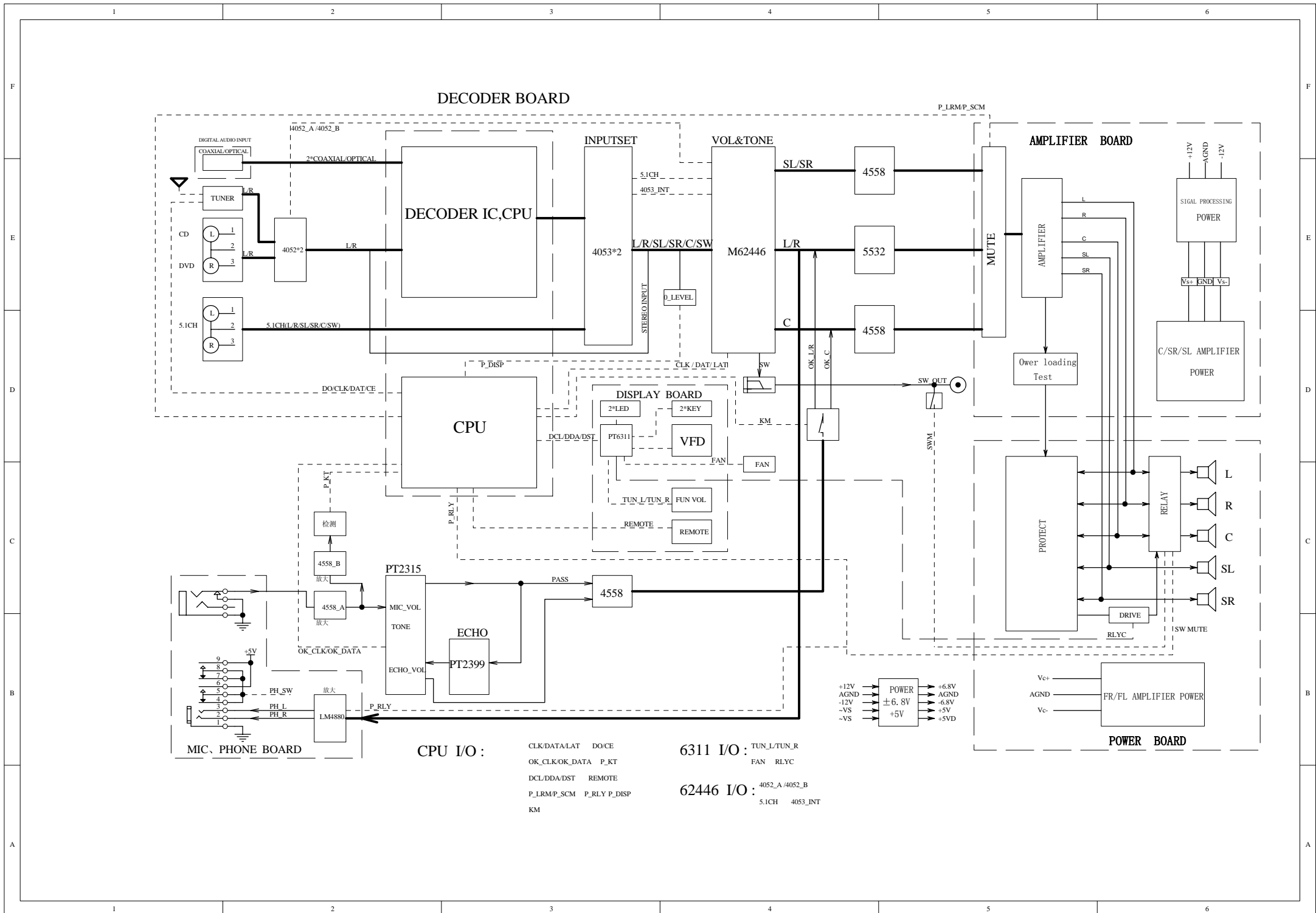

**DECODER BOARD**

P\_LRMP\_SCM

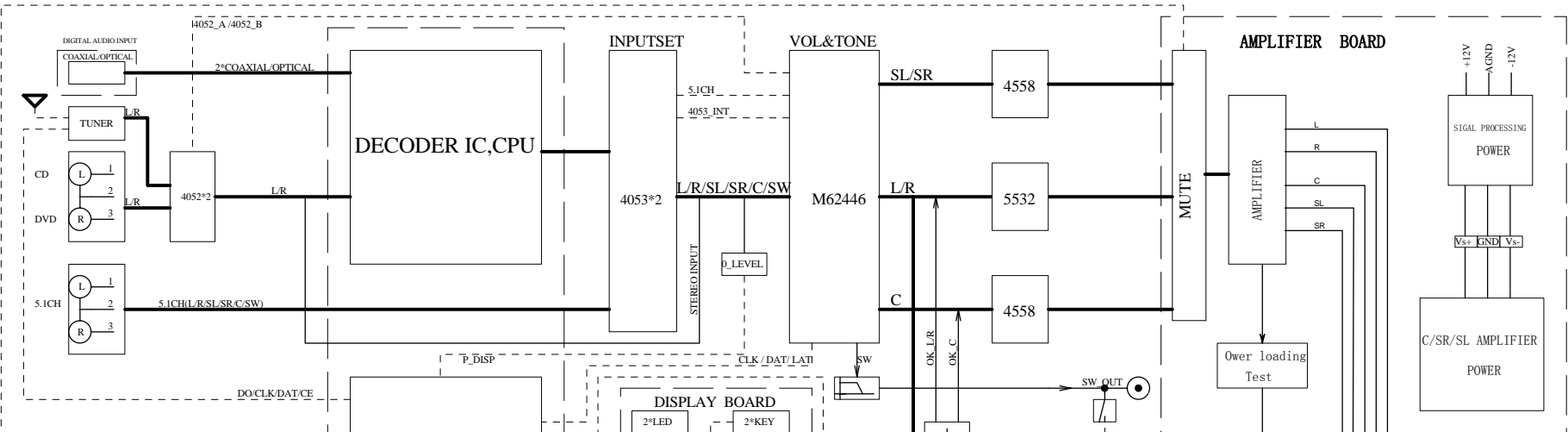

**CPU**

**DISPLAY BOARD**

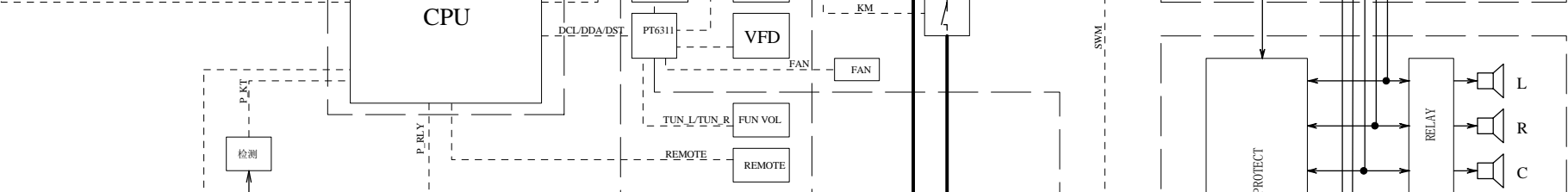

**MIC, PHONE BOARD**

**CPU I/O :**  
 CLK/DAT/LAT DOCE  
 OK\_CLK/OK\_DATA P\_KT  
 DCL/DDA/DST REMOTE  
 P\_LRMP\_SCM P\_RLY P\_DISP  
 KM

**6311 I/O :** TUN\_L/TUN\_R  
 FAN RLYC  
**62446 I/O :** 4052\_A/4052\_B  
 5.1CH 4053\_INT

**AMPLIFIER BOARD**

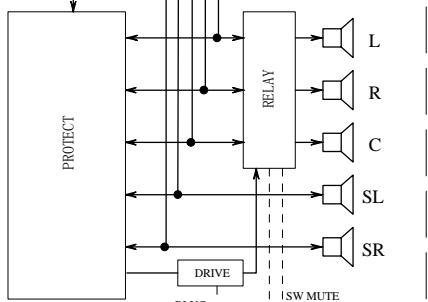
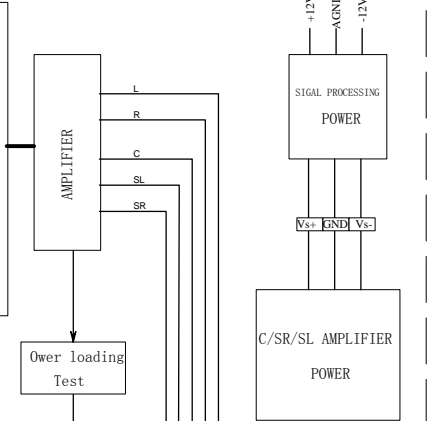

**POWER BOARD**

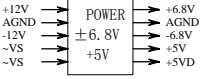

**POWER BOARD**

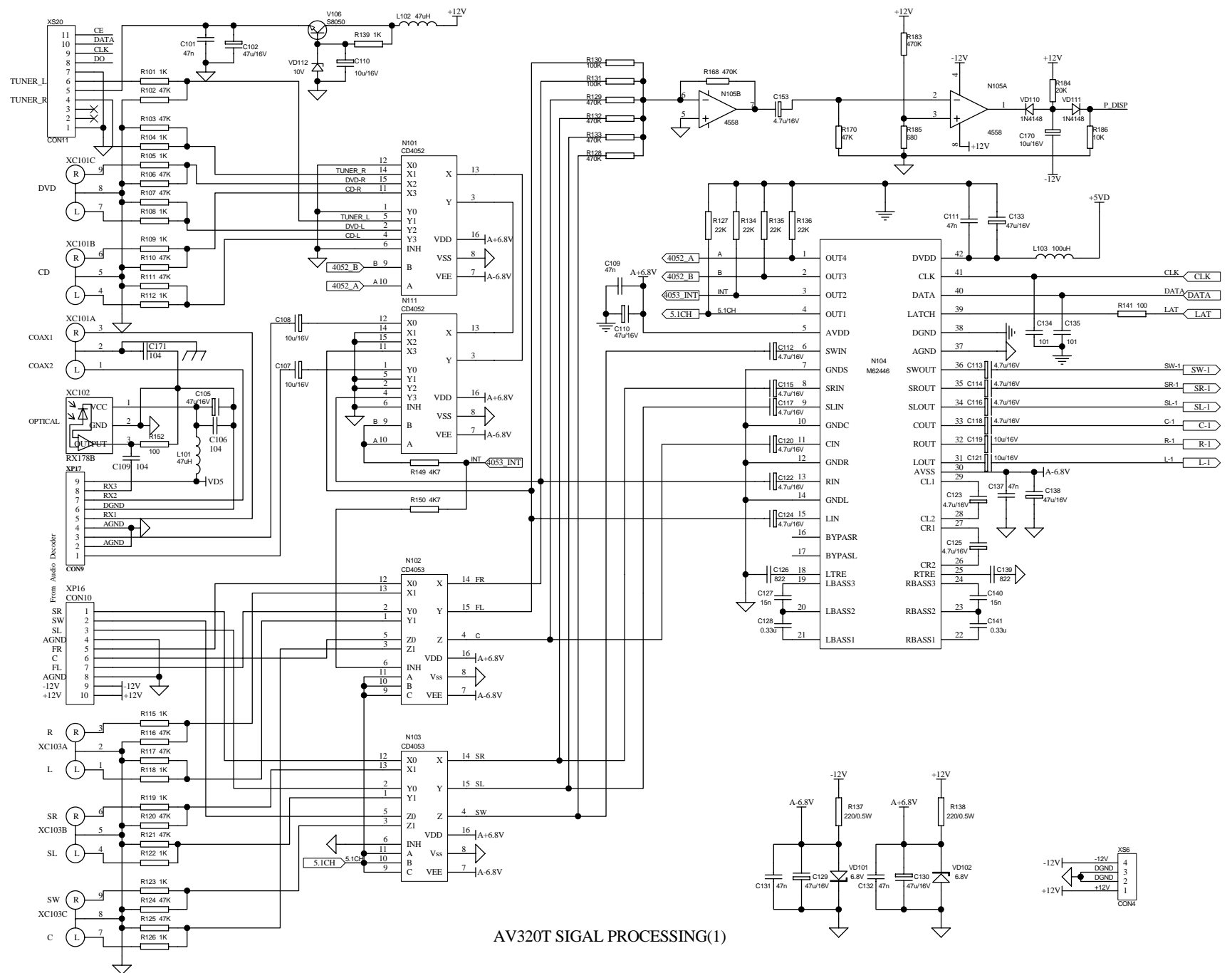

AV320T SIGNAL PROCESSING(1)

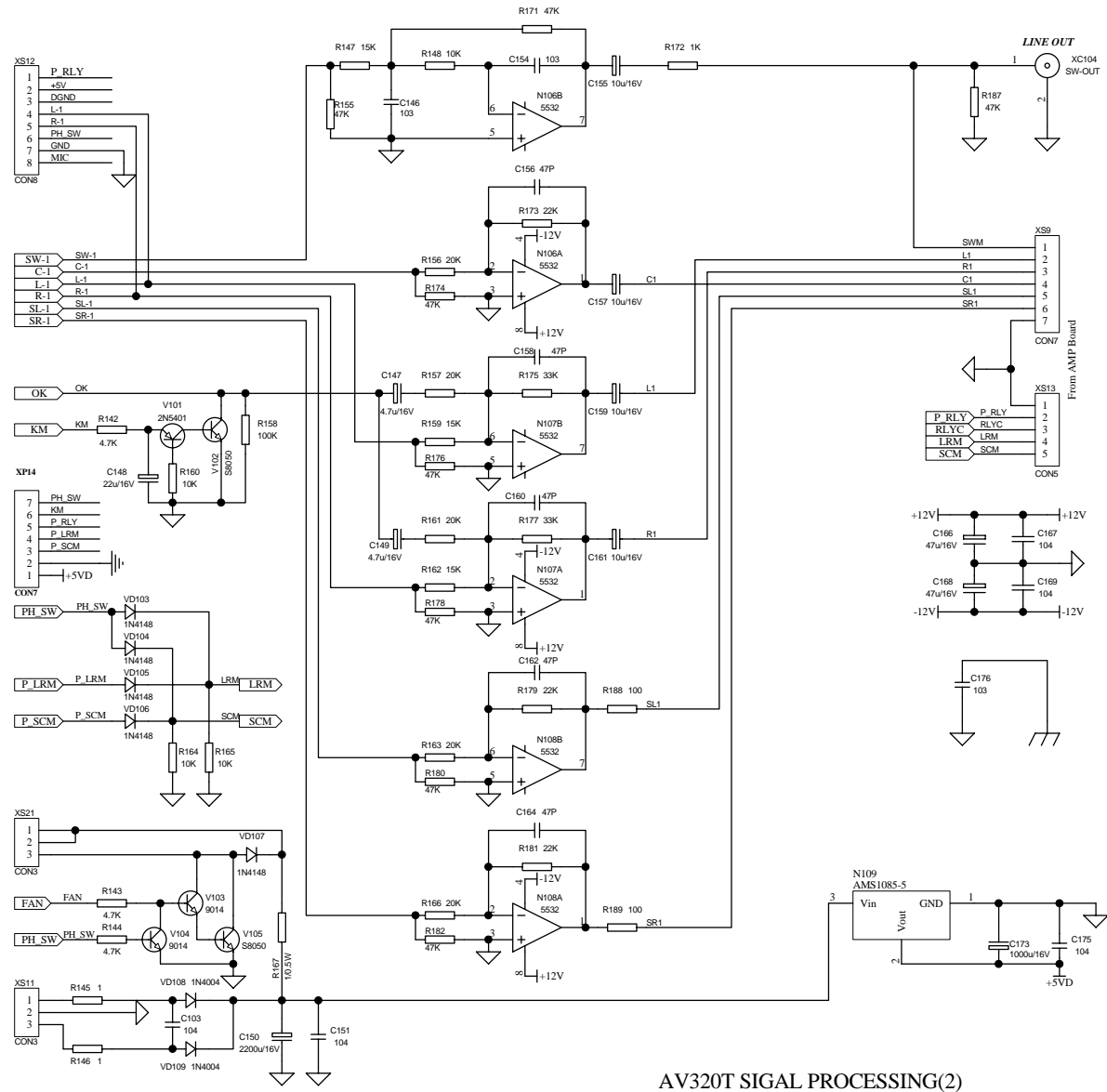

AV320T SIGNAL PROCESSING(2)

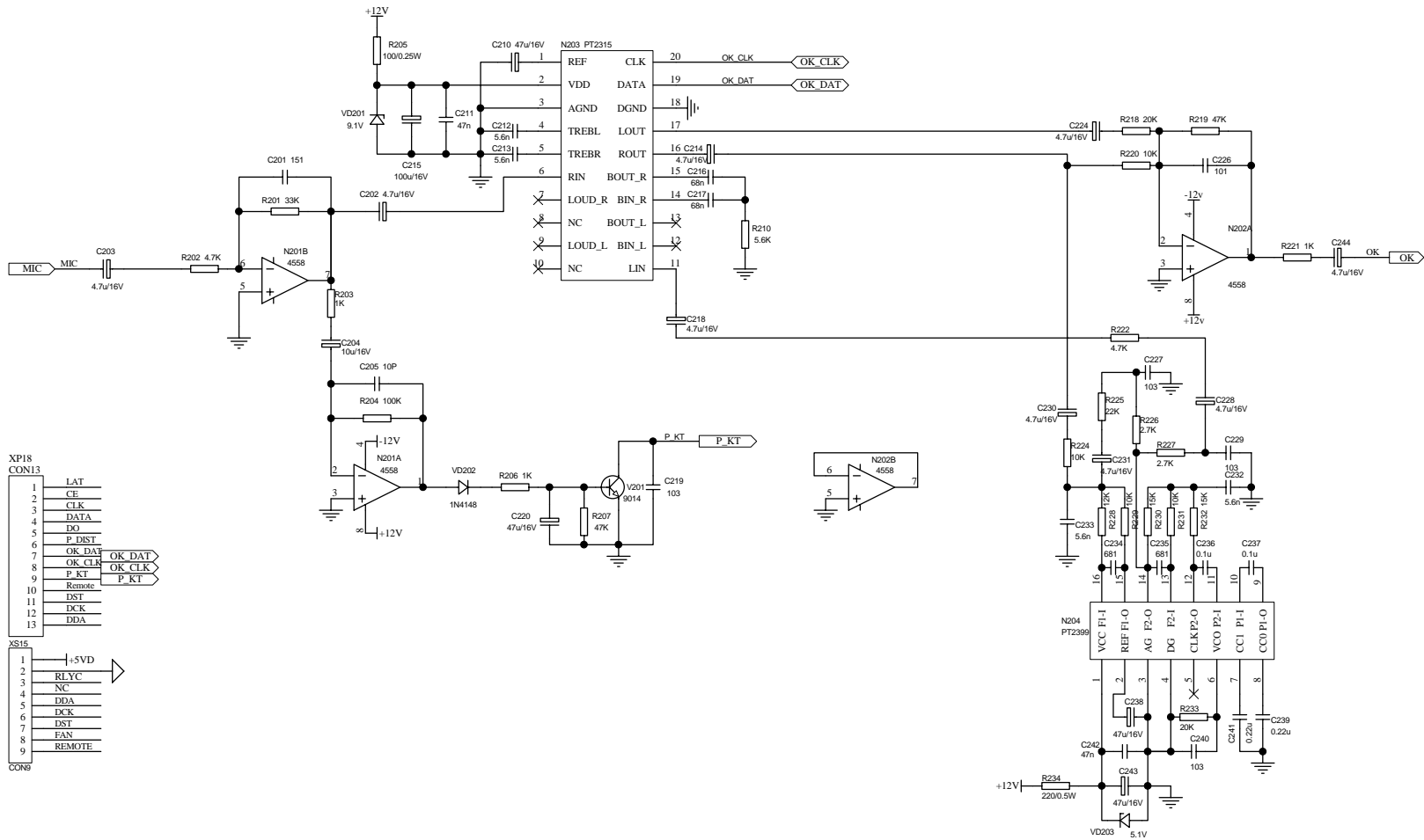

- XP18  
CON13
- |    |        |
|----|--------|
| 1  | LAT    |
| 2  | CE     |
| 3  | CLK    |
| 4  | DATA   |
| 5  | DO     |
| 6  | P DIST |
| 7  | OK DAT |
| 8  | OK CLK |
| 9  | P KT   |
| 10 | Remote |
| 11 | DST    |
| 12 | DCK    |
| 13 | DDA    |
- CON9
- |   |        |
|---|--------|
| 1 | +5VDD  |
| 2 | RLYC   |
| 3 | NC     |
| 4 | DDA    |
| 5 | DCK    |
| 6 | DST    |
| 7 | FAN    |
| 8 | REMOTE |
| 9 |        |

AV320T SIGAL PROCESSING(3).SCH

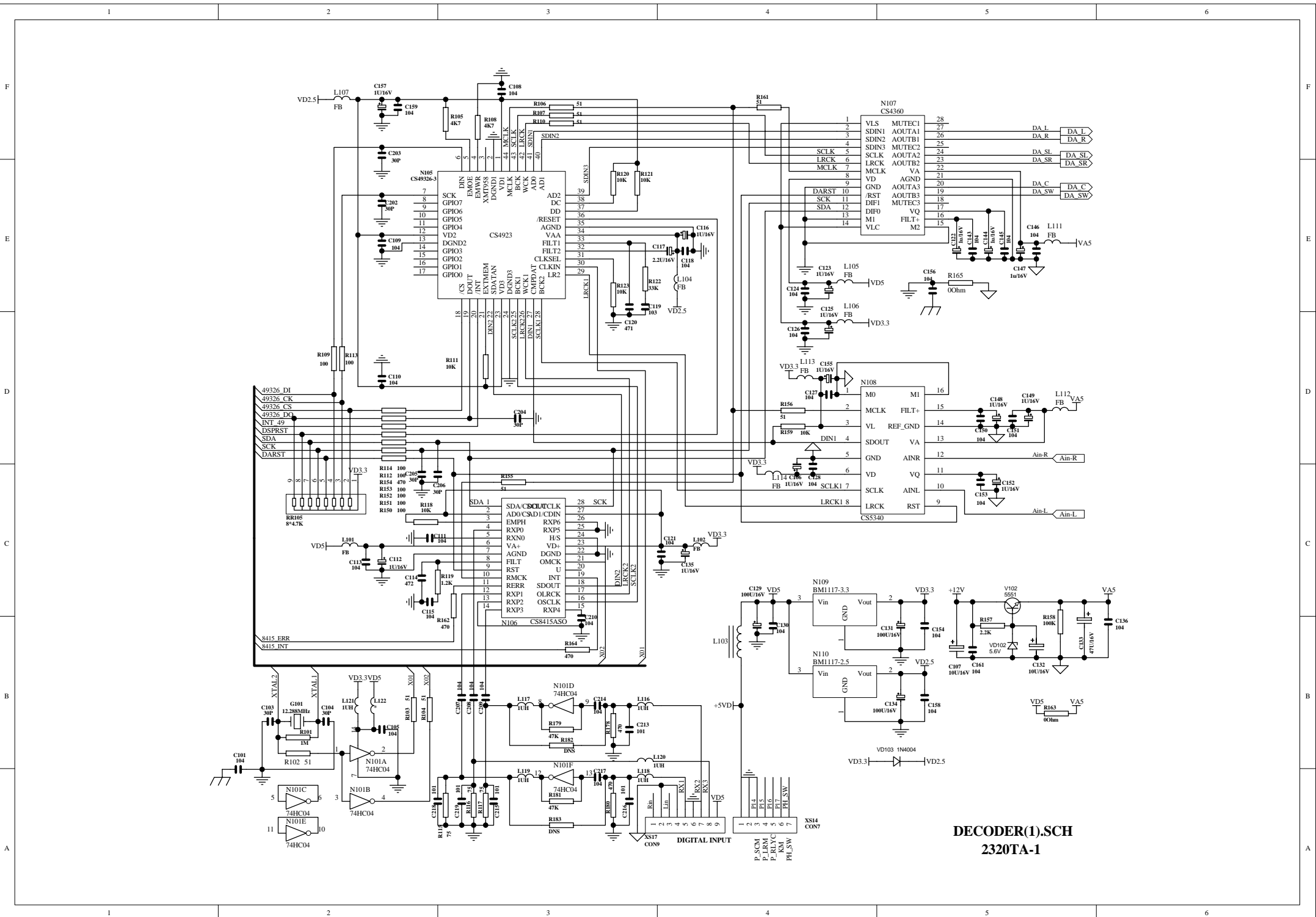

**DECODER(1).SCH**  
**2320TA-1**

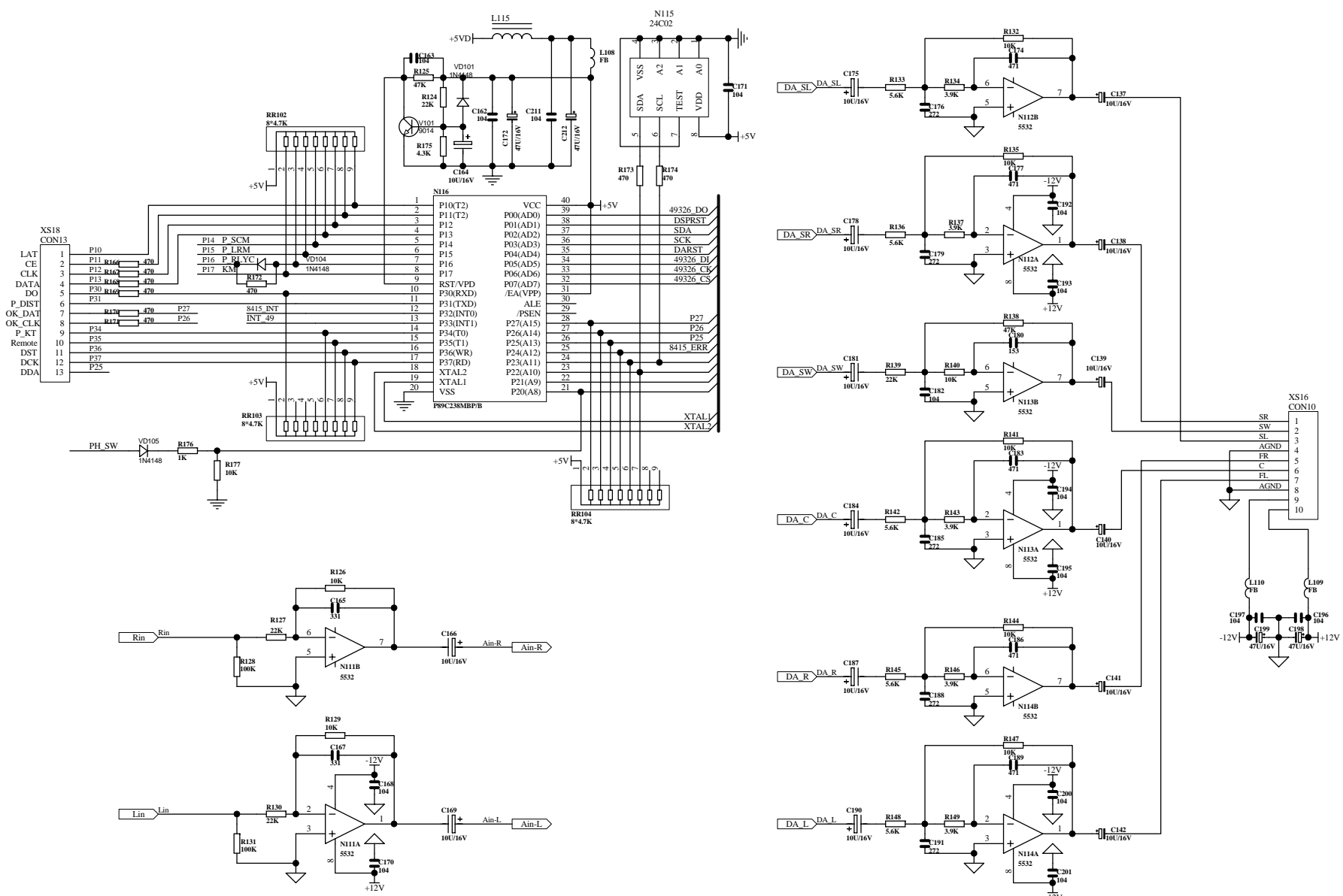

DECODER(2) SCH  
2320TB-1



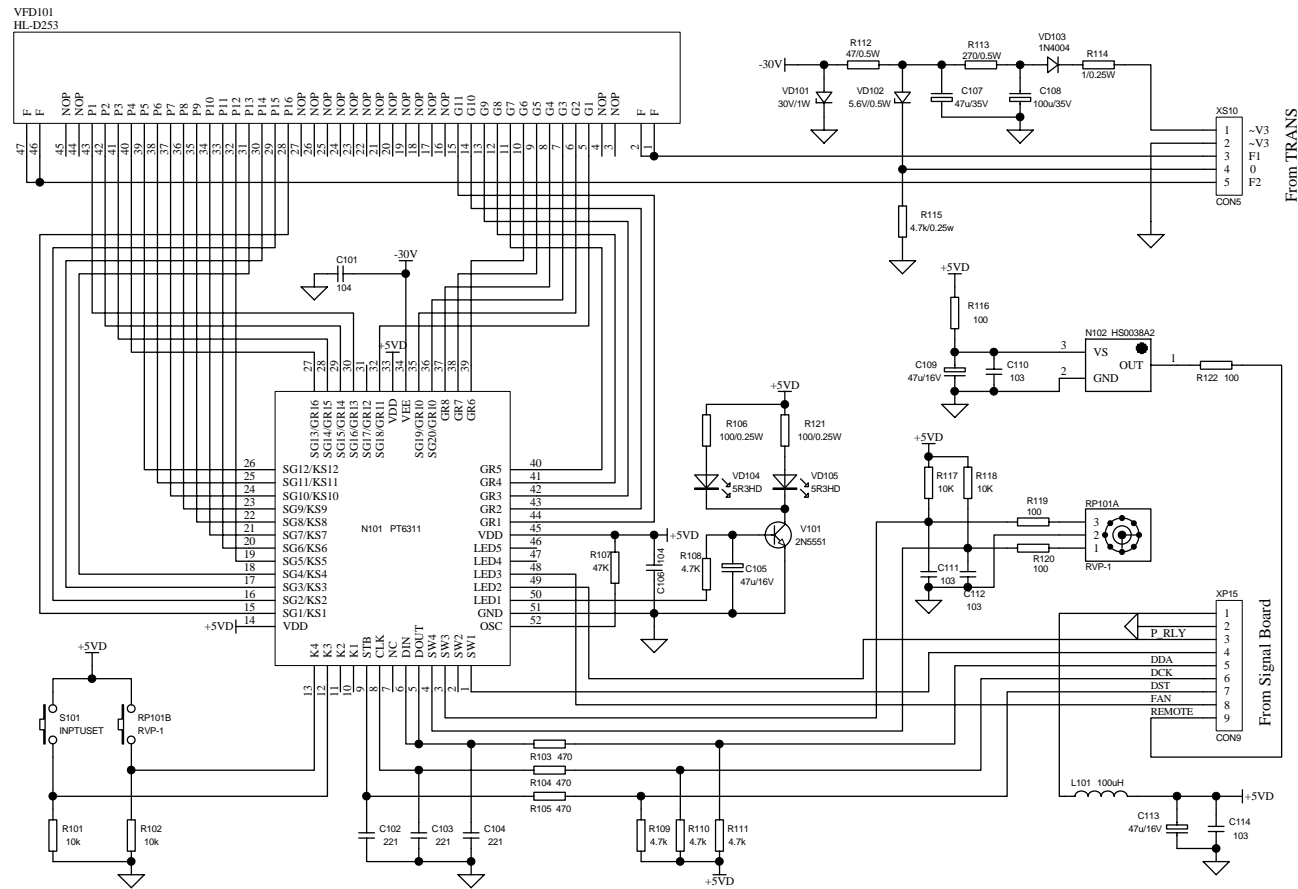

AV320T FRONT PANEL.SCH

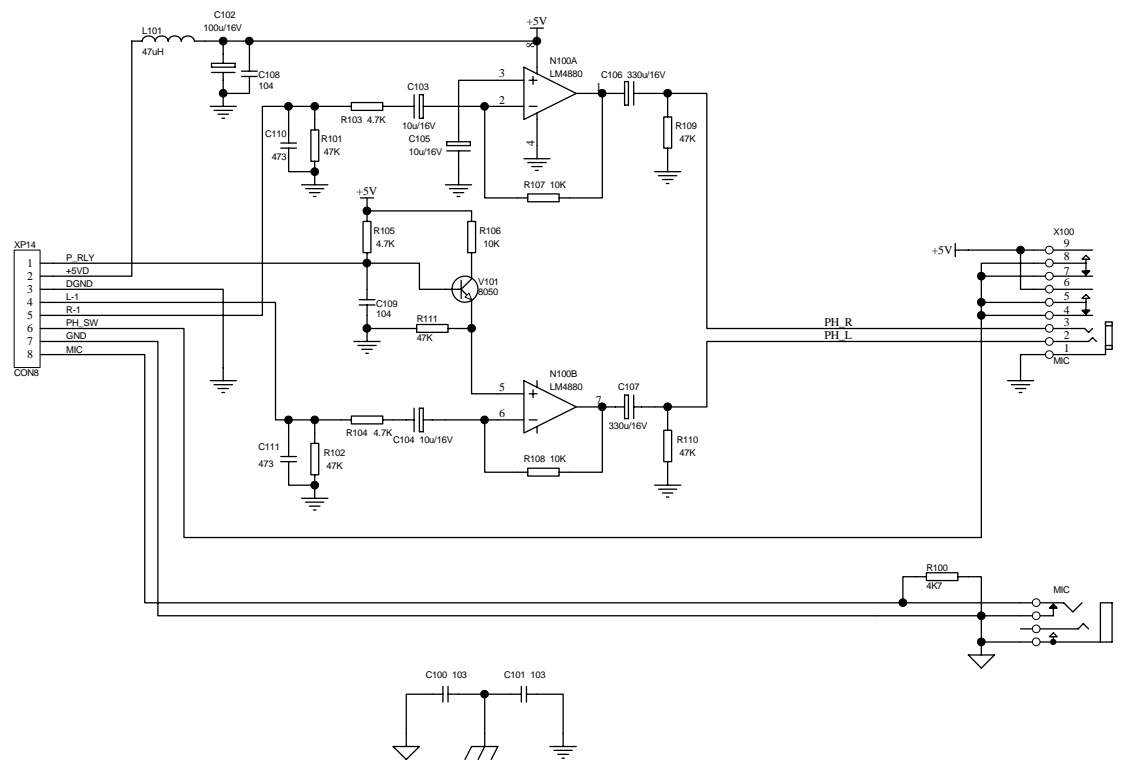

AV320T HEADPHONE.SCH

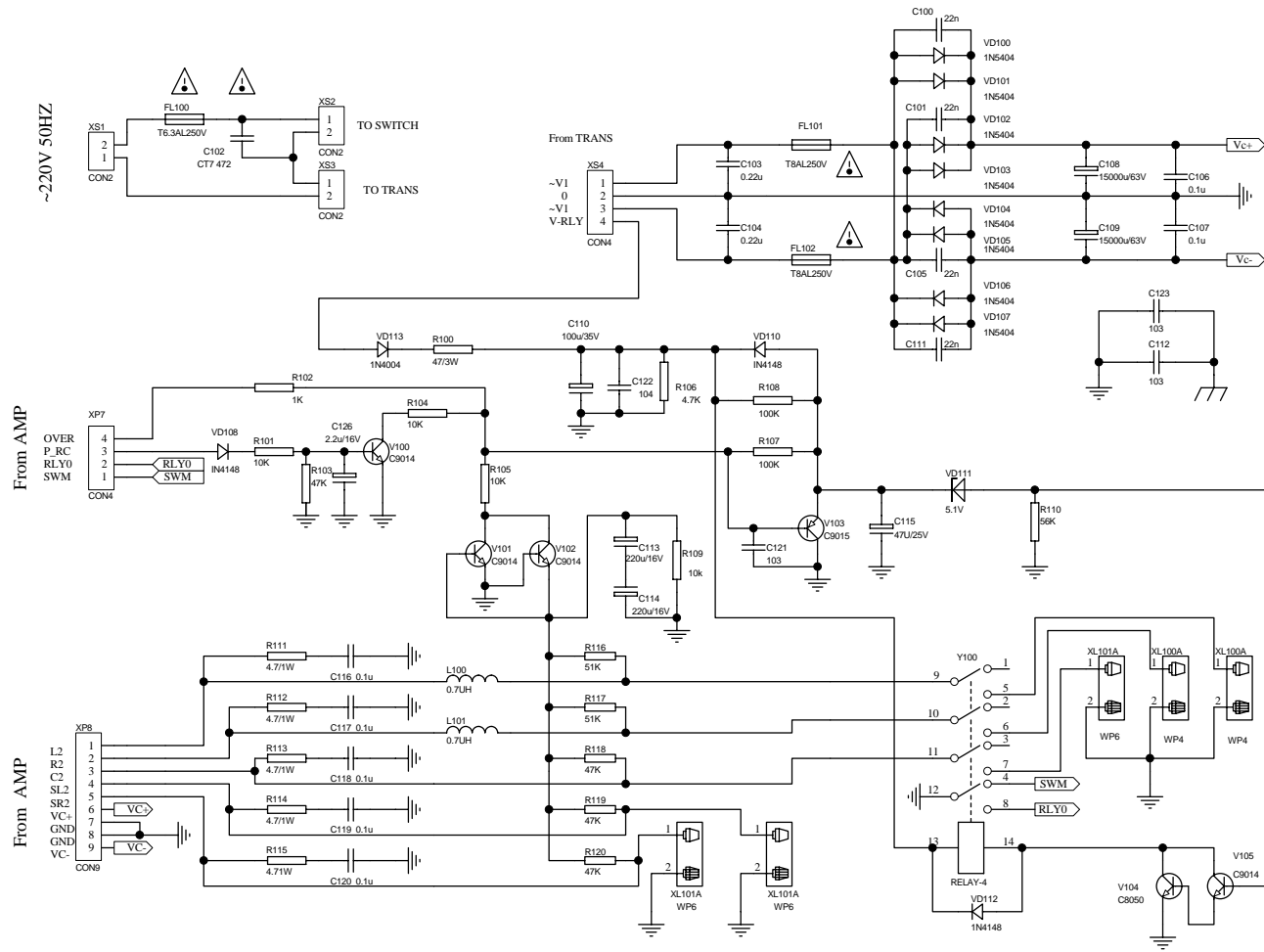

AV320T POWER.SCH

## Appendix II.

### 1、CS4360

CS4360 is a 6-channel audio digital/modulus shift circuit produced by CIRRUS LOGIC, it adjusts the digital volume through software, the adjusting coefficient of every scale is 1dB; with a fading range of 119 dB, it adopts +3.3V or +5V power voltage. With 28 pins within it, the features are described as follows:

- ①、Sampling delicacy of 24 digits
- ②、highest sampling frequency of 192KHZ
- ③、Dynamic range: 102dB
- ④、signal to noise ratio: -90 dB
- ⑤、low power: The power is 105mW at the +3.3V voltage working mode.

The function of CS4360 is as follows:

Pin	Name	Function	Pin	Name	Function
1	VLS	Serial audio power supply,+3.3V	15	M2	Mode 2
2	SDIN1	Serial audio Data1 input	16	FILT+	In-phase feedback voltage output
3	SDIN2	Serial audio Data1 input	17	VQ	Out Filter of static working voltage
4	SDIN3	Serial audio Data1 input	18	MUTE3	Output 3 mute control
5	SCLK	BCLK	19	AOUTB3	Simulated Audio 3 output
6	LRCK	Right and left channel clock	20	AOUTA3	Simulated Audio 3 output
7	MCLK	Main clock input	21	GND	ground
8	VD	Digital power, +3.3V	22	VA	Simulated power, +5V

9	GND	ground	23	AOUTB2	Simulated Audio 2 output
10	RST	Restoration input	24	AOUTA2	Simulated Audio 2 output
11	SCL	Serial control clock	25	MUTE2	Output 2 mute control
12	SDA	Serial control data	26	AOUTB1	Simulated Audio 1 output
13	CS/M1	Chip choice/mode 1	27	AOUTA1	Simulated Audio 1 output
14	VLC	Power-supply for Control port,+3.3V	28	MUTE1	Simulated Audio 1 output

## 2、CS 4923

CS4923 is a data processing IC, including DOLBY decoding, DTS decoding and DSP processing, the function of its main pins are as follows:

PIN 30: main clock input

PIN 31: the alternating internal clock to Clock DSP when port is low

PIN 8—11、14—17: data address output and data input port

PIN 7: I<sup>2</sup>C formula communication clock input port

PIN 19: I<sup>2</sup>C formula communication data input port

PIN 5: address and data output and input lock

PIN 21: outer memorizing choice

PIN 36: restoration input port

PIN 22: PCM audio data input 1

PIN 27: PCM audio data input 2

PIN 25、28: PCM audio data input clock 1 and 2

PIN 26、29: PCM audio data sampling rate output port

PIN 42: audio data sampling rate output port

PIN 39、40、41: digital audio output port

PIN 43: audio data output position clock

PIN 44: main audio clock

## 4. CS5340

CS5340 is a dual-channel A/D shift IC, its function is to turn the simulated signal into PCM signal for CS4923 to process the digital sound field. The main functions of its main pins are as follows:

PIN1、PIN16: mode choice

PIN2: main audio clock

PIN3: digital signal input and output power

PIN4: audio data output

PIN5、PIN14: pin to ground

PIN6: digital power

PIN7: rate sampling control

PIN8: right and left clock signals

PIN9: restoration signal

PIN10、PIN12: input of simulated signals

PIN13: power for simulated sections

PIN15: in-phase reference voltage

## 5. CS 8415

PIN1: input and output control data line

PIN2: bytes control

PIN4、PIN5: serial audio signal input port

PIN12-15, PIN25、26: added serial audio signal input port

PIN6: power supply

PIN9: restoration signal

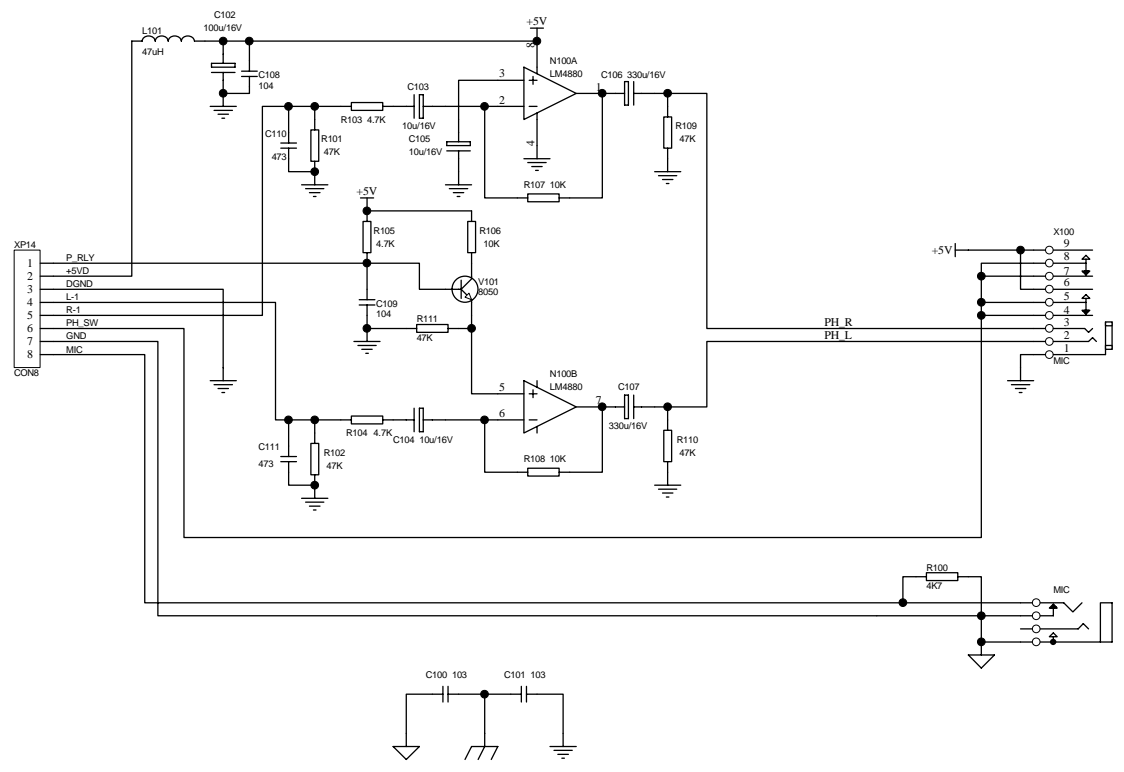

AV320T HEADPHONE.SCH

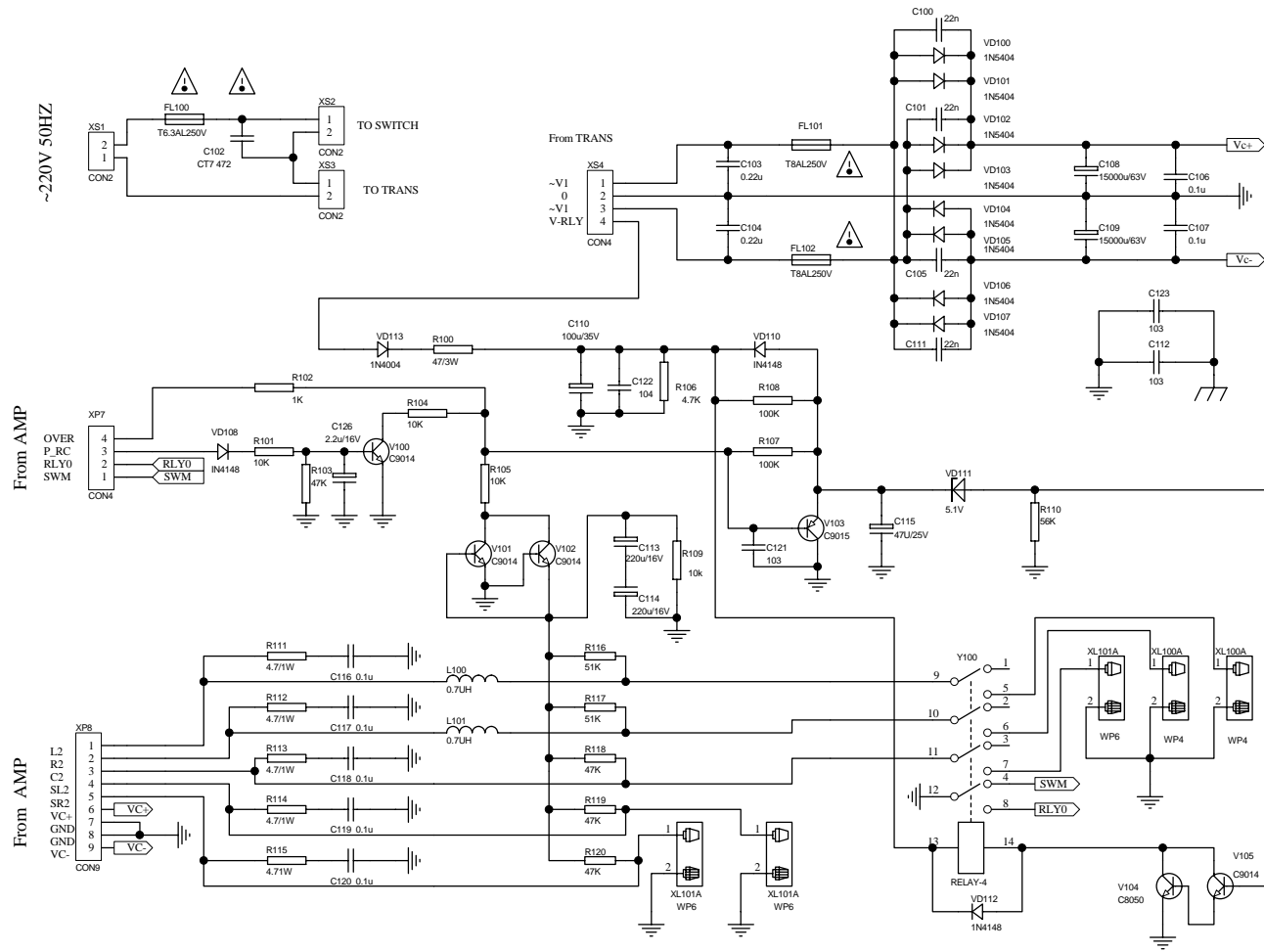

AV320T POWER.SCH



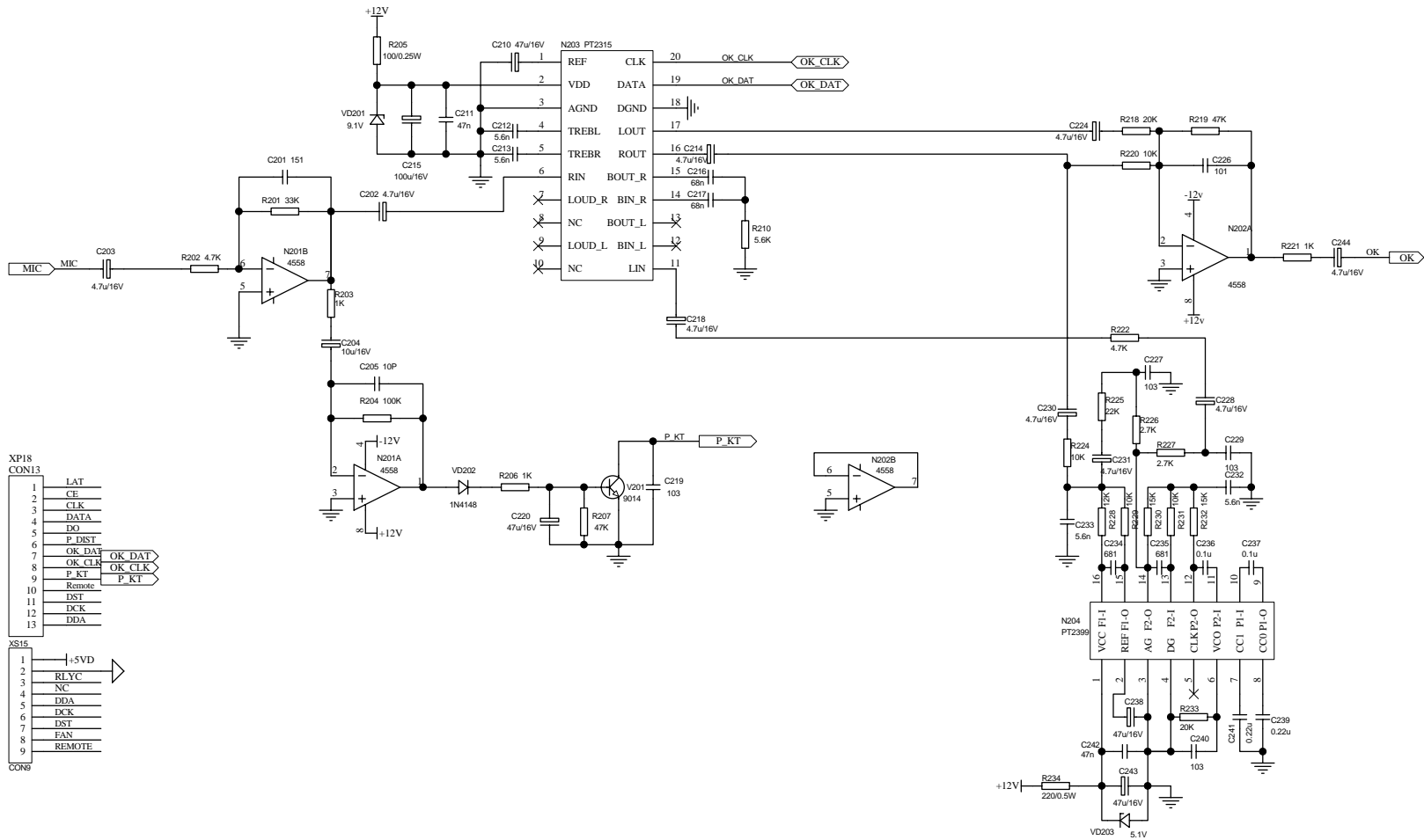

XP18  
CON13

1	LAT
2	CE
3	CLK
4	DATA
5	DO
6	P DIST
7	OK DAT
8	OK CLK
9	P KT
10	Remote
11	DST
12	DCK
13	DDA

XS15

1	+5VDD
2	RLYC
3	NC
4	DDA
5	DCK
6	DST
7	FAN
8	REMOTE
9	

CON9

AV320T SIGAL PROCESSING(3).SCH

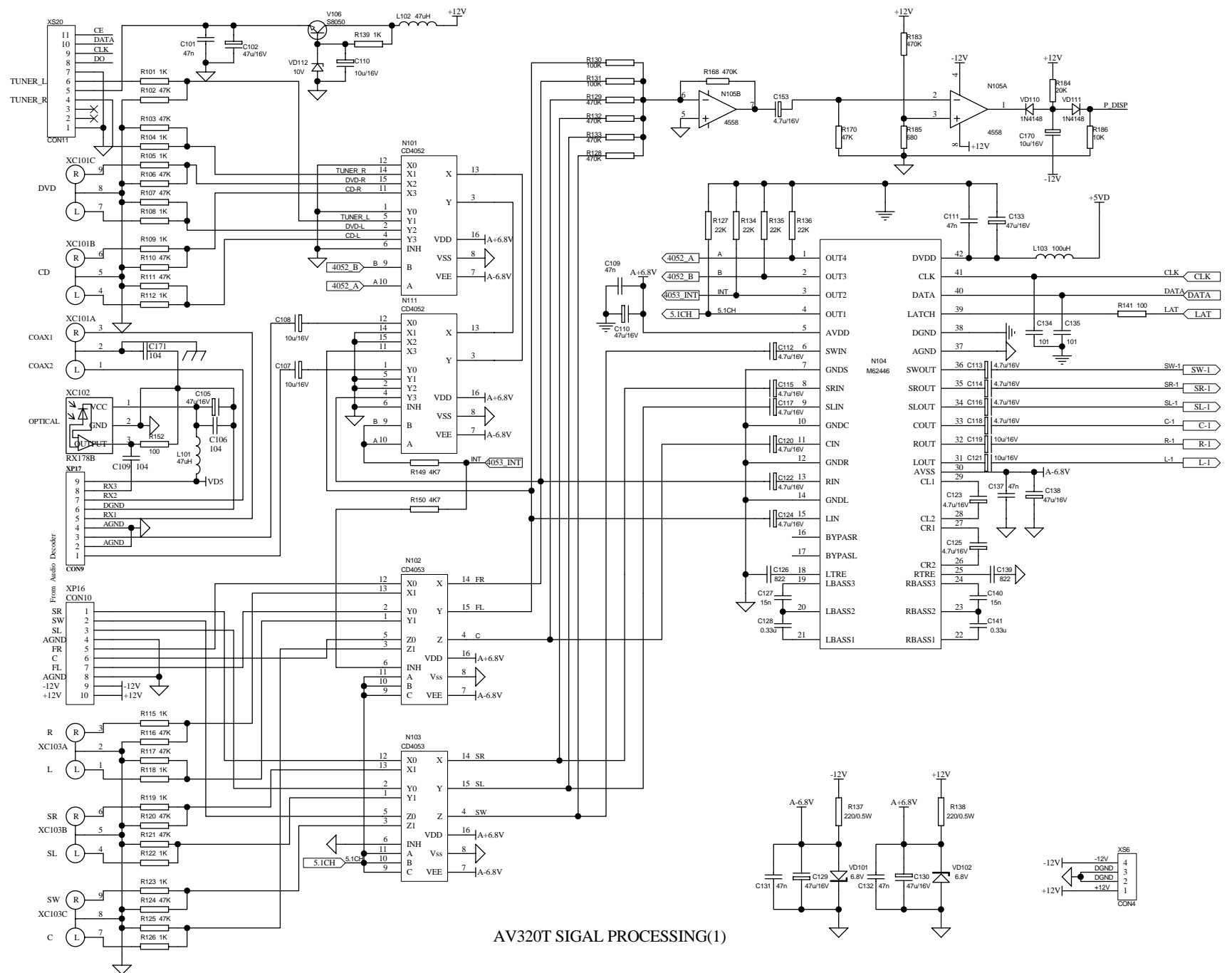

AV320T SIGNAL PROCESSING(1)

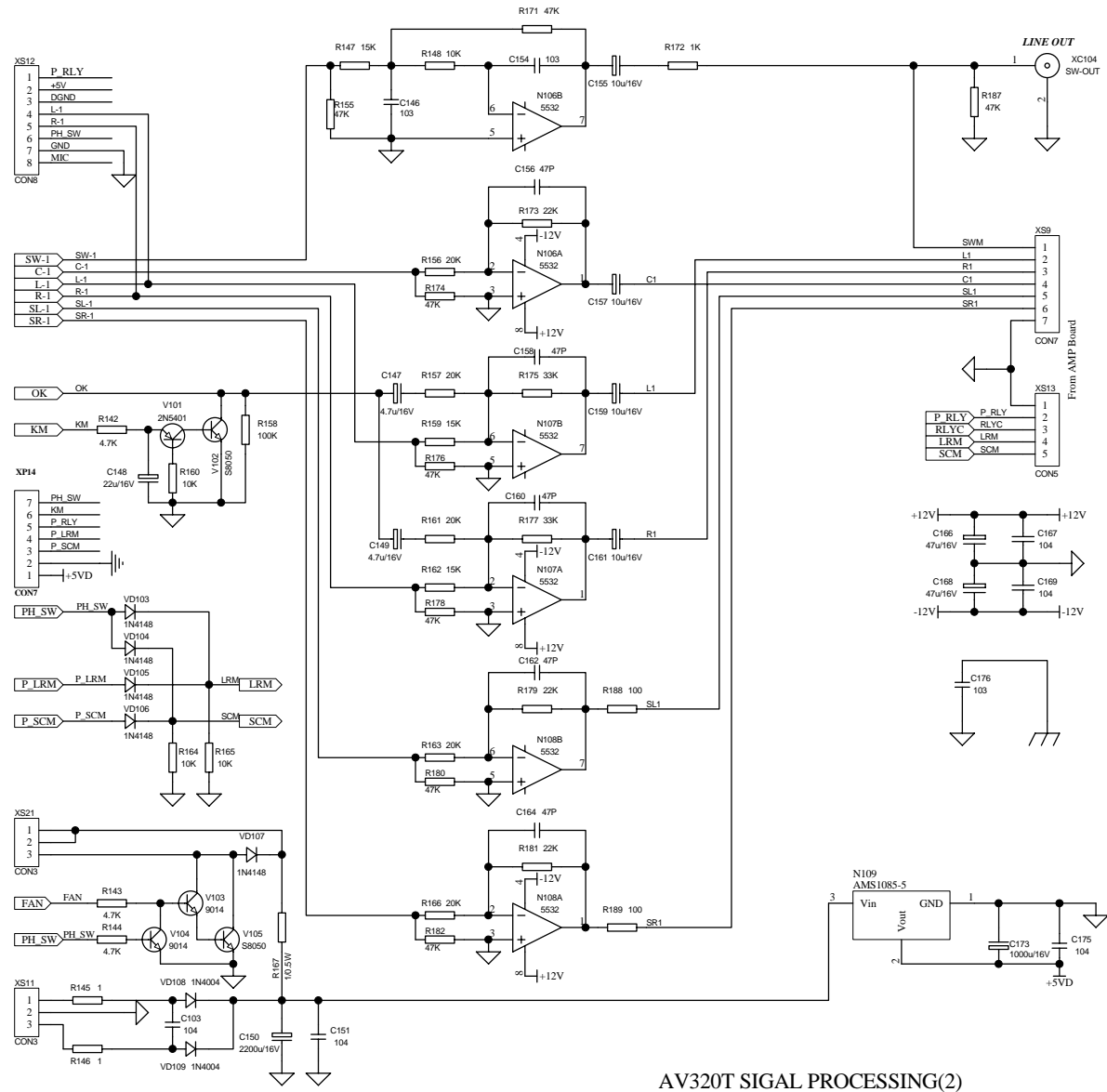

AV320T SIGNAL PROCESSING(2)

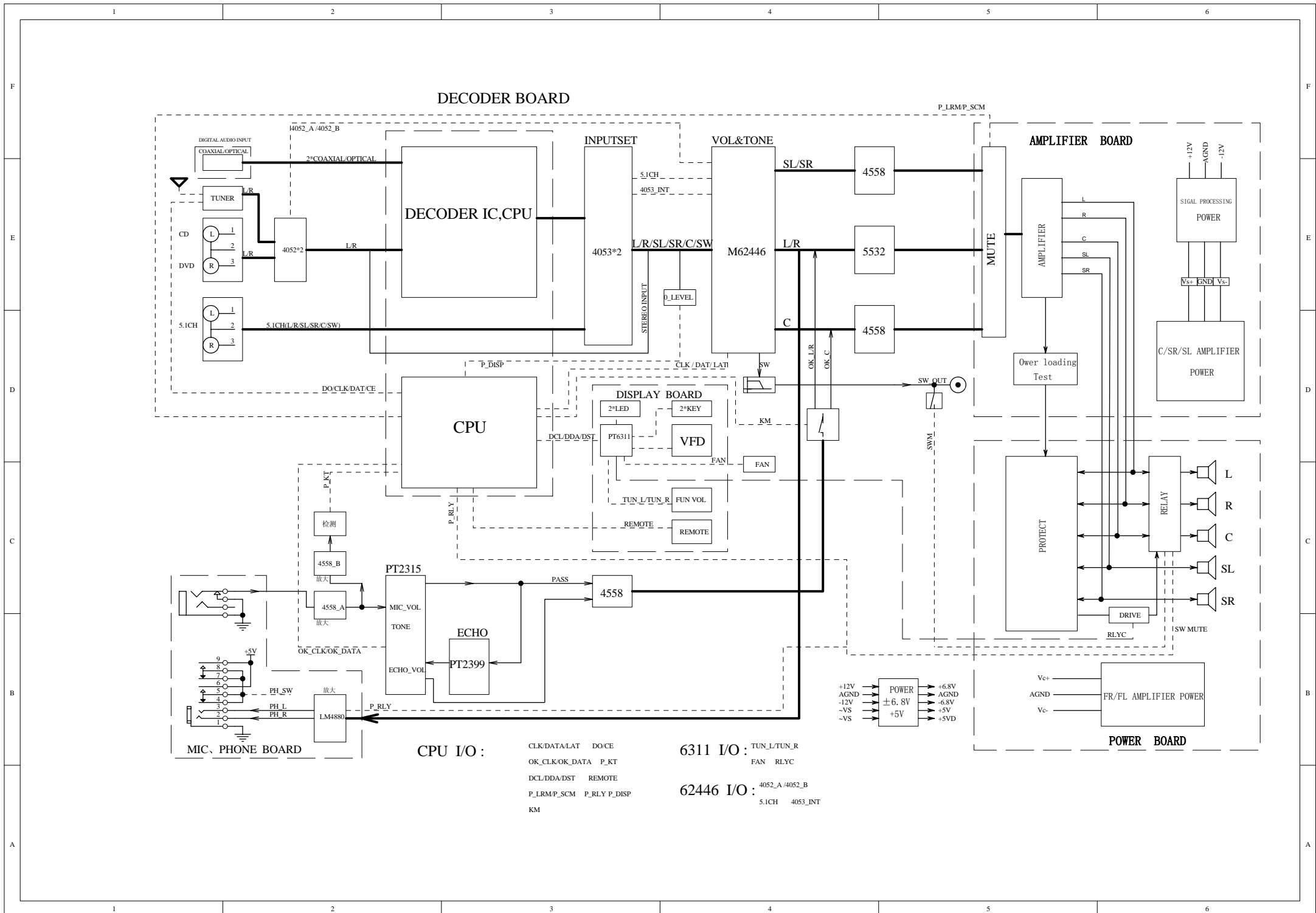

**DECODER BOARD**

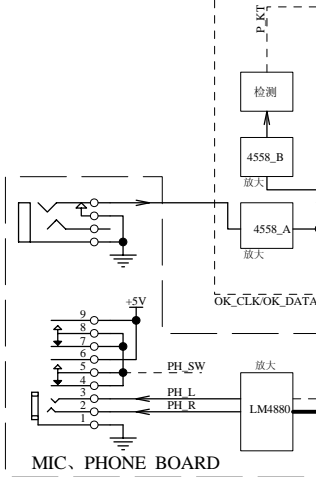
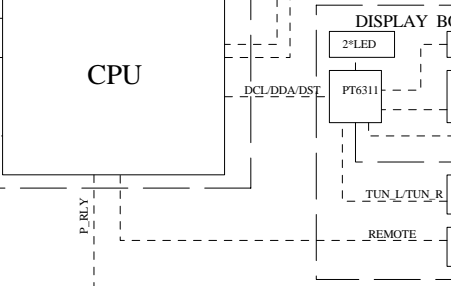
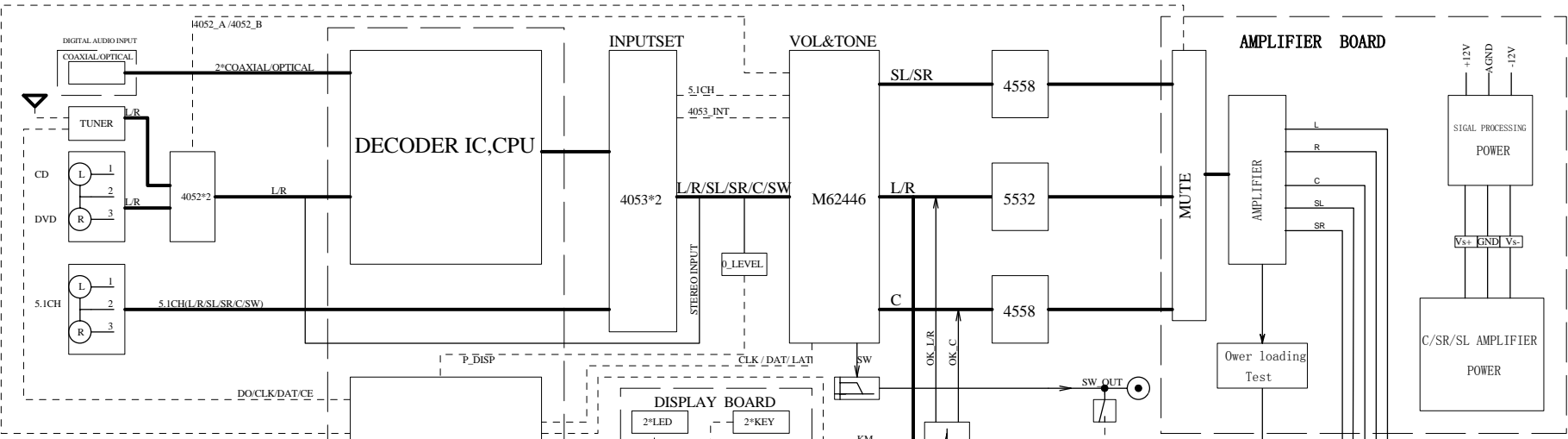

**CPU I/O :**

- CLK/DAT/LAT
- DOCLK/DAT/CE
- OK\_CLK/OK\_DATA
- P\_KT
- DCL/DDA/DST
- REMOTE
- P\_LRMP\_SCM
- P\_RLY
- P\_DISP
- KM

**6311 I/O :**

- TUN\_L/TUN\_R
- FAN
- RLYC

**62446 I/O :**

- 4052\_A/4052\_B
- 5.1CH
- 4053\_INT

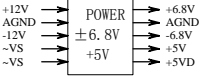
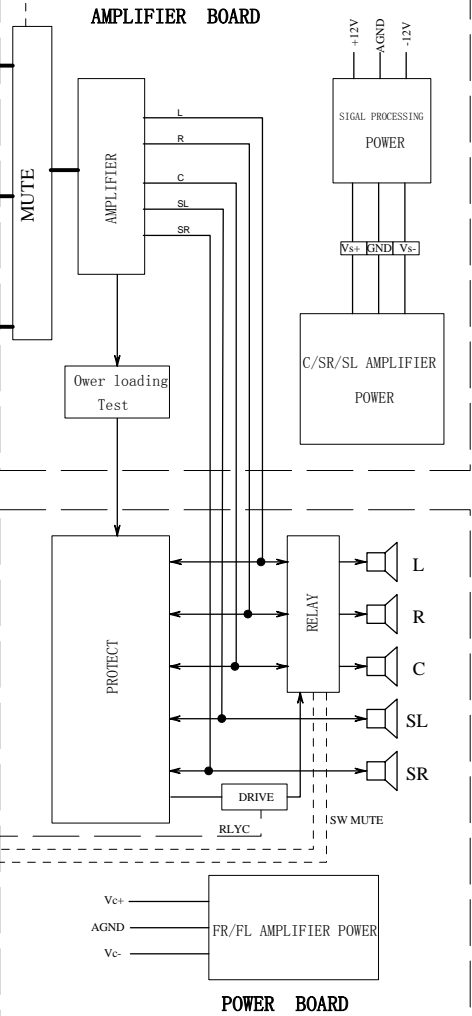

**POWER BOARD**