

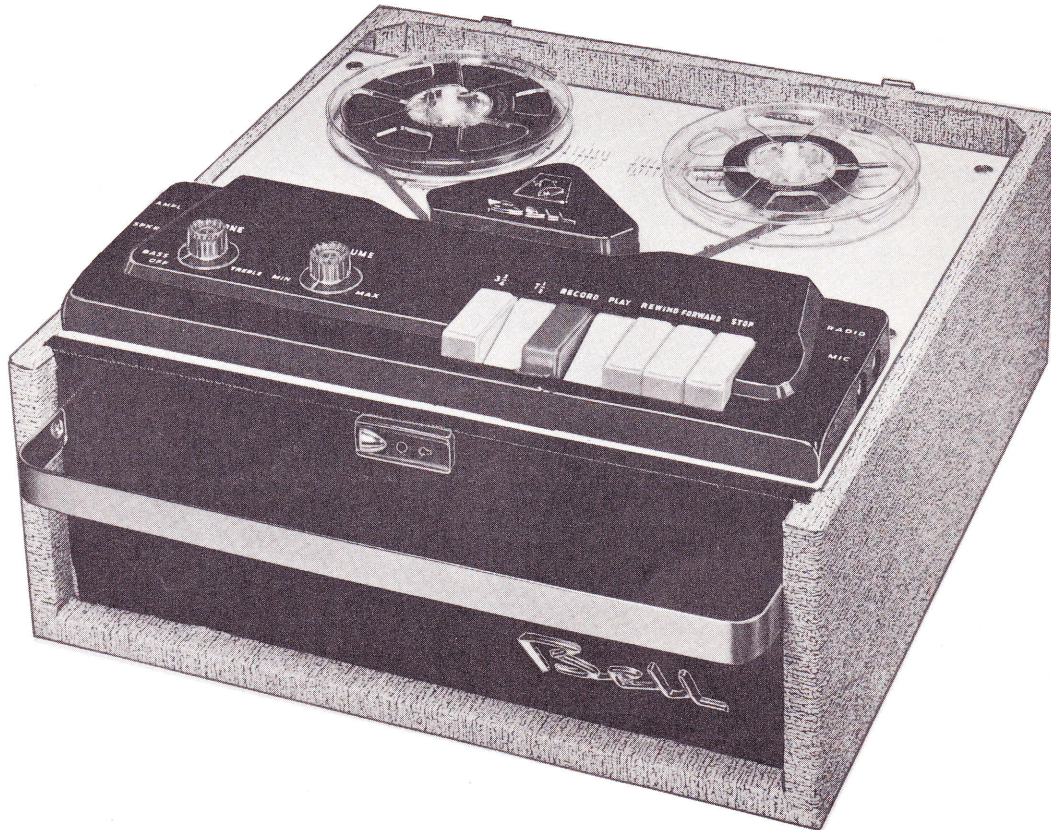

BELL SOUND
MODEL RT-204



BELL SOUND
MODEL RT-204

GENERAL INFORMATION

The Bell Model RT-204 is designed to record and play back two tracks of material on standard width recording tape (1/4"), which doubles the playing time of a standard 5" or 7" reel of tape with no loss of frequency response or quality. Recordings can be made from a radio, television receiver or phonograph, in addition to those made directly from the microphone. Recordings can be played back through the self-contained speaker or external speaker through use of the External Speaker Jack.

The Bell Model RT-204 has two tape speeds, 7 1/2" and 3 3/4" per second. Using both tracks, the recording time is as followed:

Size Reel	3 3/4" Speed	7 1/2" Speed
5" (600 ft.)	1 hour	1/2 hour
7" (1200 ft.)	2 hours	1 hour

The Bell Model RT-204 is designed to operate on 60 cycle, 110-120 volts, AC supply only.

Manufactured by:

BELL SOUND SYSTEMS, INC.
A SUBSIDIARY OF THOMPSON PRODUCTS, INC.
555 MARION ROAD
COLUMBUS, OHIO

This material compiled and published by

HOWARD W. SAMS & CO., INC., INDIANAPOLIS, INDIANA

Copyright 1957 • All Rights Reserved

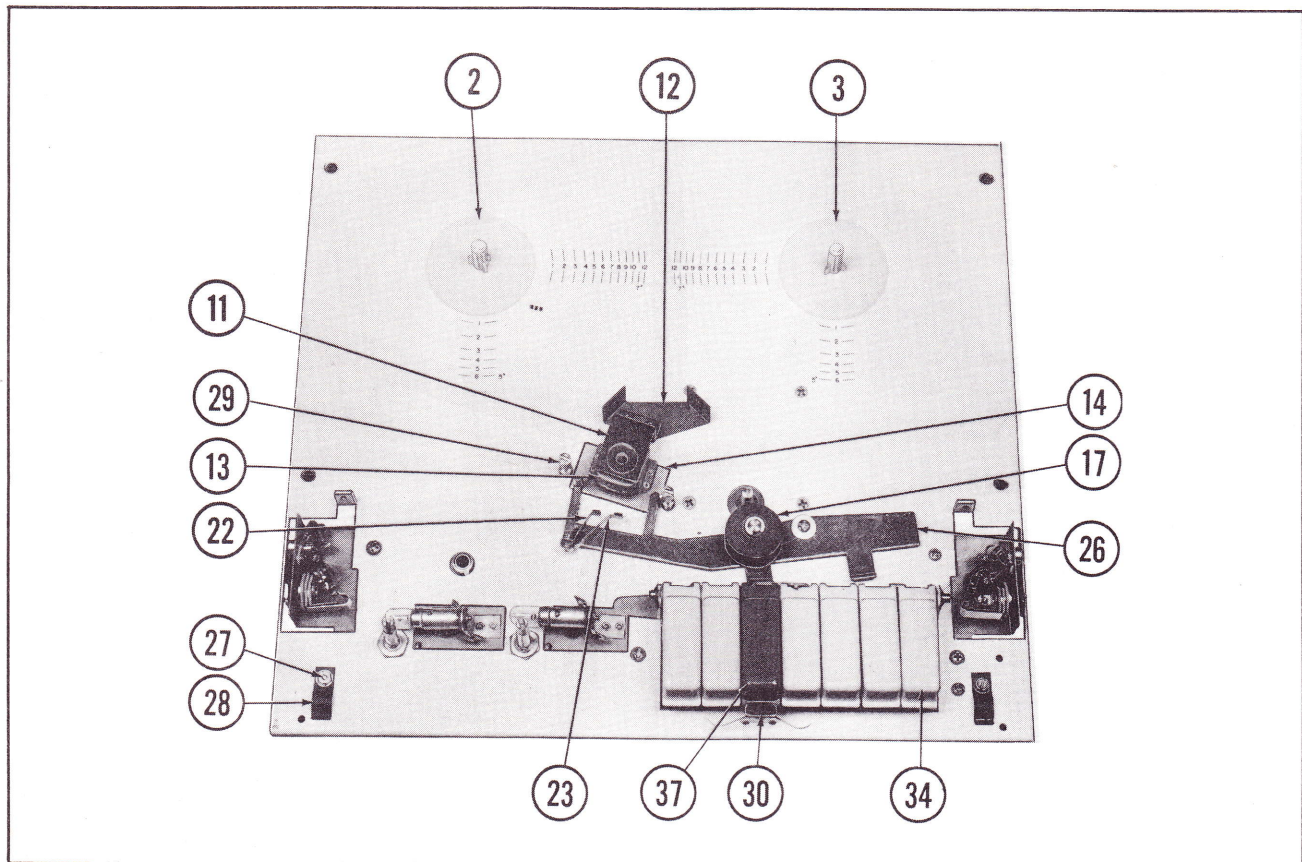

FIGURE 1

GENERAL DESCRIPTION

The Bell Model RT-204 is a dual track tape recorder having seven piano-type keys for controlling tape speed, record, play, rewind, forward, and stop modes.

This Bell Tape Recorder has been designed to eliminate adjustments which may cause a problem in the use and servicing of this machine. Three motors are used, rewind, capstan, and takeup. As a result, moving parts on the transport mechanism have been held to a minimum.

Two output jacks permit use of an external speaker or high fidelity amplifier system. When the speaker jack is used, the self-contained speaker is automatically disconnected.

Recordings may be monitored through high or low impedance headphones, external speaker, or an external amplifier.

Built in interlocks prevent the operator from placing the machine in more than one mode at a time. The "Stop" key must be depressed before going from one mode to another, except when changing speed. This prevents tape breakage, spillage, and accidental erasure.

A removable cover plate on the bottom of the cabinet allows easy access to tubes, motors, and hum adjustment.

Model RT-204 is designed to operate on 60 cycle, 110-120 volts, AC supply only. Severe Damage Will Result If Connection Is Made To A Direct Current (DC) LINE.

SPECIFICATIONS

Frequency Response: 30 to 10,000 cycles at 7 1/2 inches per second.

Speeds (two): Play or record. 7 1/2 or 3 3/4 inches per second.

Fast Forward: 5" reel - 25 ± 2 second.
7" reel - 45 ± 5 second.

Fast Rewind: 5" reel - 25 ± 2 second.
7" reel - 45 ± 5 second.

Wow and Flutter: Less than .3% at 7 1/2 I.P.S.
Less than .5% at 3 3/4 I.P.S.

OPERATING INSTRUCTIONS

Preparing For Operation —

1. Open and remove the lid by sliding it to the right of the hinges. Place the recorder on a hard flat surface so that the feet will allow air to enter the bottom grille for ventilation.

2. Insert the AC power cord plug into a convenient 110-120 volt, 60 cycle AC outlet.

Threading The Tape —

Place a reel of "A" wind tape (glossy side out) on the supply reel platform (2). Turn the reel while pressing down lightly so that the three slots in the reel hub engage the three keys on the reel platform. Place an empty reel on the take-up reel platform (3) and draw the end of the tape across and into the hub of the empty reel. Insert the end of the tape into one of the slots in the hub of the empty reel and rotate reel counter clockwise until tape is secured to hub. Drop the tape into the tape slot and take up slack in tape before turning unit on.

NOTE: This machine will operate in either a horizontal or vertical position. When operating with the front panel in a vertical position, use the two rubber reel spindle tips to hold the reels firmly on the spindles. Remove these (pull off) when loading tape on machine.

To Record From Microphone —

Depress the "Stop" key, then turn on the recorder by rotating the "Tone" control clockwise. Depress the desired speed key and allow approximately 30 seconds for the unit to warm up. Insert the microphone plug into the Mic. jack. Next, pull the record lock (30) toward the front of the case and depress the red record key. The tape will move and all sounds striking the microphone will be recorded on the tape if the "Volume" control is turned up sufficiently. The correct volume control setting is that which causes the record level lamp (located under the "Volume" control knob) to flash on peak sounds. If the lamp fails to light, volume is too low. If the lamp flashes constantly, volume is too high. The "Volume" control should be set from 1/2 to 3/4 of maximum.

To Record From Radio, Phono or TV —

The most satisfactory method is to connect the "Radio" input of the recorder to the radio or TV voice coil terminals.

In the case of an AM-FM Tuner, connect to the tuner output where there are no tone controls in the circuit. If this is not feasible, be sure tone controls are in a flat position. Also, cut out any loudness controls since these accentuate bass and treble frequencies.

To record from a phonograph equipped with a crystal cartridge, connect the cartridge directly into the "Radio" input on the recorder. When using a magnetic cartridge, connect a preamp between the cartridge and "Radio" input on the recorder.

After the proper connections are made, proceed with the recording as described under "To Record From Microphone".

NOTE: In order to obtain the best recording quality, volume control on the RT-204 should be at a 50% setting or above when the record level lamp flashes on peak sounds. If the volume control, when recording, must be turned down to a low setting (say 1/4 of the way up or 25%) to obtain proper flashing of the lamp, it means that the signal being fed into the recorder is too high. To avoid possible distortion, place the microphone farther away from the source, or turn down the volume of the radio or phonograph so that the RT-204 volume control can be advanced to 50% or higher for proper recording level.

Dual Track Operation —

When recording has used up the full tape length, except for a few turns on the supply reel (left hand side), turn reels over and exchange end for end placing the now full reel on the supply platform and the now empty reel (except for a few turns) on the take-up platform. Proceed with the recording as described under "To Record From Microphone".

Either track may be played back at any time by turning the reels over and exchanging platforms.

To Rewind —

After recording is made, press the "Stop" key all the way down, then depress the "Rewind" key. When desired portion of tape is rewound, push down "Stop" key. Wait for the tape to stop before pressing the "Play" key.

To Play a Recording —

1. To play back a tape recorded on the RT-204 or to play a commercial pre-recorded tape, install reels on platforms and thread as for recording. Turn unit "On", select proper speed, and depress "Play" key. Adjust "Volume" and "Tone" controls for desired listening level. After playing, depress the "Stop" key.

2. To play back second track, turn reels over and place on opposite reel platforms. This may be done at any time during playback.

To Use External Speaker —

Recordings may be played back through an external speaker by inserting a phone plug in the speaker jack. This jack when used, disconnects the built-in speaker.

To Use External Amplifier —

Recordings may be played back through a Hi-Fi system by connecting to the "Ampl." output jack. To silence internal speaker while in "Play" position, insert a phone plug, miniature type, into the "Spkr." output

BELL SOUND
MODEL RT-204

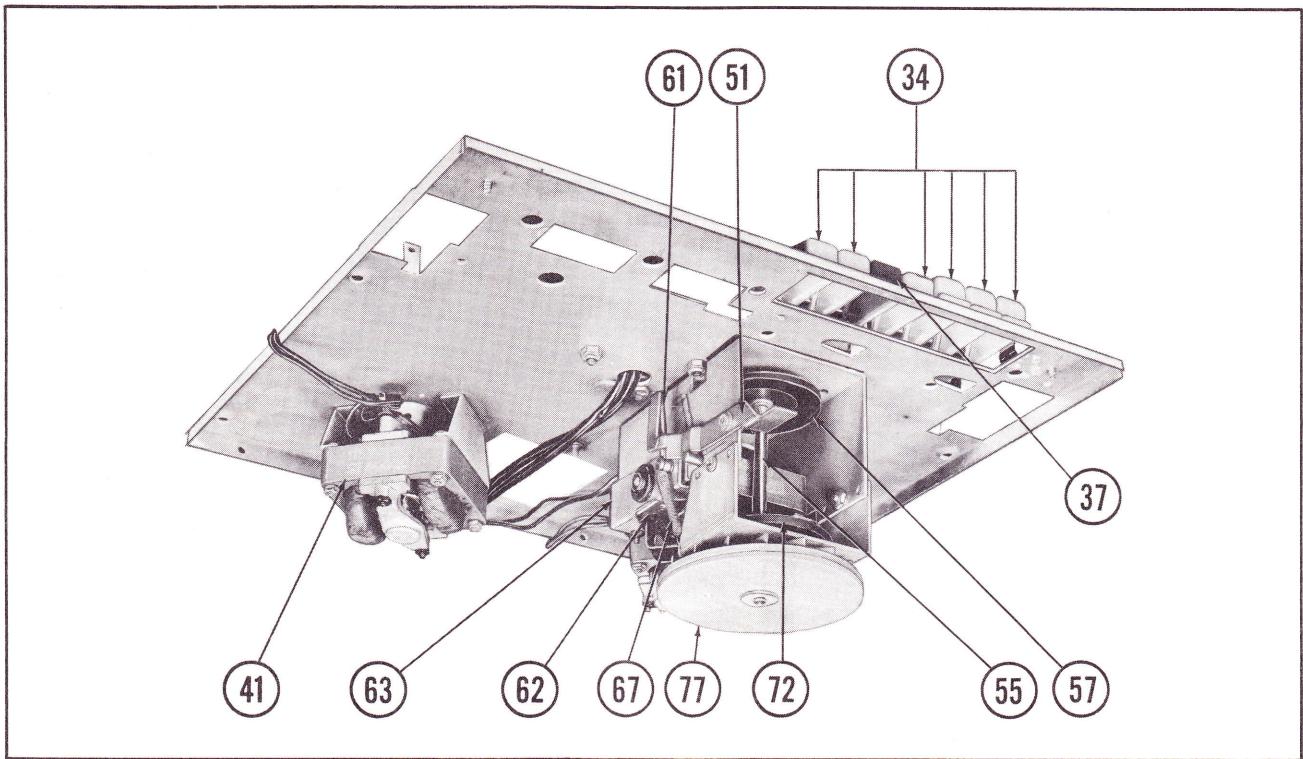

FIGURE 2

jack. For best results, the phone plug should be terminated in a 6 ohm resistor.

Fast Forward —

In playback, it is sometimes desirable to skip portions of tape to a particular spot. To do this, push down "Forward" key until tape arrives at desired spot; then depress "Stop" key. Be sure keys are pressed all the way down. Wait for the tape to stop before pressing the "Play" key.

To Monitor Recordings —

Any signal being recorded may be monitored by plugging high or low impedance phones into the "Spkr." output jack.

An external amplifier may be used to monitor any signals being recorded if connected to the "Amp." jack. An external speaker may also be used. Use "Spkr." output jack.

DISASSEMBLY INSTRUCTIONS

To Remove Recorder From Cabinet —

Remove the four Phillips-head screws located at the edges of the top deck plate and lift the unit straight

up from the case. Disconnect speaker leads from speaker before lifting unit completely out of case.

ADJUSTMENTS

Head And Pressure Pad Adjustments —

To properly check head azimuth alignment it is necessary to have a pre-recorded 1 mil alignment tape which results in a 7500 cycle per second signal when operated at 7 1/2 inches per second. Play alignment tape back through recorder with an AC VTVM connected across the speaker or 6Ω load.

CAUTION: Be sure recorder is in "Play" position to prevent erasure of alignment tape.

Three things can cause low meter readings (providing amplifier and tubes are working properly). These are, dirty head, improper pressure pad pres-

sure, or wrong head alignment angle. Check these things as follows:

1. Check head to be sure there is no dirt on the pole pieces or bakelite portion. Dirt holds the tape away from the pole pieces and lowers output. If head is dirty, clean with head cleaning solvent or alcohol. Wipe dry immediately after cleaning.

2. Check that pressure pads (22 and 23) cover the head pole faces. The pressure at the spring side of the play-record pad (23) should be 30 grams and the pressure at the spring side of erase pad (22) should be 20 grams. Bend pad springs only when necessary, avoiding odd-appearing kinks in the springs.

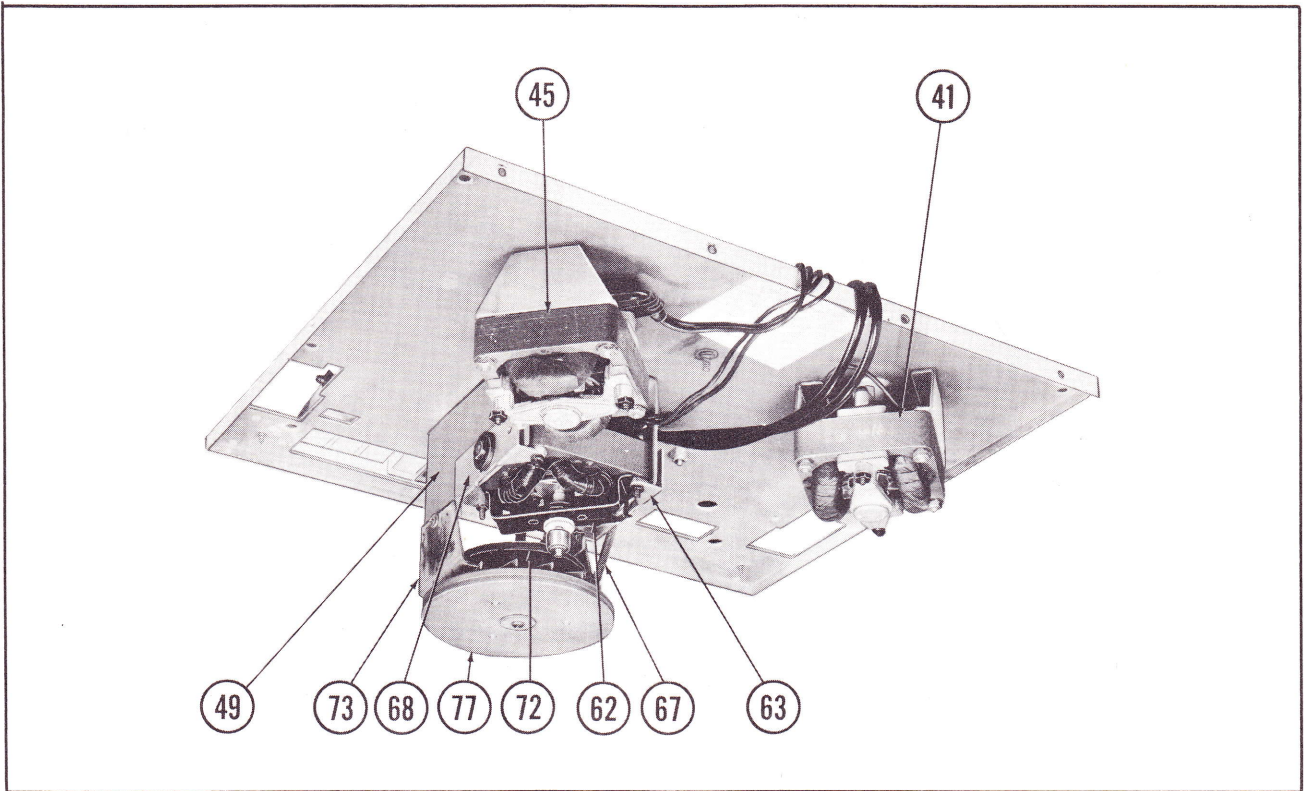

FIGURE 3

3. To adjust head alignment by means of tape guide heights without destroying the correct nominal tape height at the head, proceed as follows:

Set both left and right tape guides (29) to .486" (at top surface) off of panel. With head fully seated, run the 7500 cycle alignment tape through the machine with the "Volume" and "Tone" controls full on. Adjust the left tape guide by rotating not more than plus or minus 1/2 turn ($\pm 0.016''$). If this fails to produce a peak voltage reading on the AC vacuum tube voltmeter, adjust the right tape guide by not more than $\pm 1/4$ turn ($\pm 0.008''$). This amount of adjustment will tilt the tape by more than the normal head mis-alignment and if no peak is reached either the head is not fully seated or the head mounting plate (14) is bent, or the head itself is worn. Tape position must be such that, when playing back a tape having the opposite track recorded to normal level no crosstalk will be audible in the playback (slight crosstalk may be audible in ideal listening conditions).

Reel Platform Adjustment -

The reel platforms (2 and 3) must clear the deck plate by 1/32" minimum - 1/16" maximum and both reel platforms must be the same height on a given machine. Adjustment is made by loosening set screw (4) and positioning reel platform (2) or (3) to the correct height. After adjustment is made, tighten set screw (4).

Hum Adjustments -

Measure hum output voltage across 6Ω load, "Volume" control maximum and "Tone" control minimum.

The hum balance control (R3) on the amplifier should be adjusted first for minimum amplifier hum but will probably have to be slightly re-adjusted for lowest overall hum, i.e., the hum voltage will help cancel hum induction into the head from the power transformer and motors. Minimum hum voltage in playback is obtained by correctly polarizing the power transformer and motors, correctly polarizing the line cord plug, adjusting the hum balance pot for minimum hum, and selecting the pre-amp tube (V1) if necessary.

Procedure for Motor Phasing - in "Play" Position But Without Tape.

1. With all motors disconnected and the head shorted, the amplifier should have only a 10 to 15 mv hum output. With the head connected, hum is from the power transformer and should be under 50 mv. This can be reduced by shimming the transformer mounting spacers to tilt the transformer (only necessary in extreme cases).
2. Plug in the take-up motor (45) in the direction giving lowest hum. Check hum balance control (R3).
3. Plug in capstan motor (62) in the direction giving lowest hum - do not change take-up motor connections. Check hum balance control (R3). Brown wire on common should be minimum.
4. Plug in rewind motor (41) in the direction giving lowest hum. This motor will introduce 120 cycle hum which will not be helped by the hum balance control, however it sometimes affects hum balance slightly and the hum control should be adjusted after this last motor is connected.

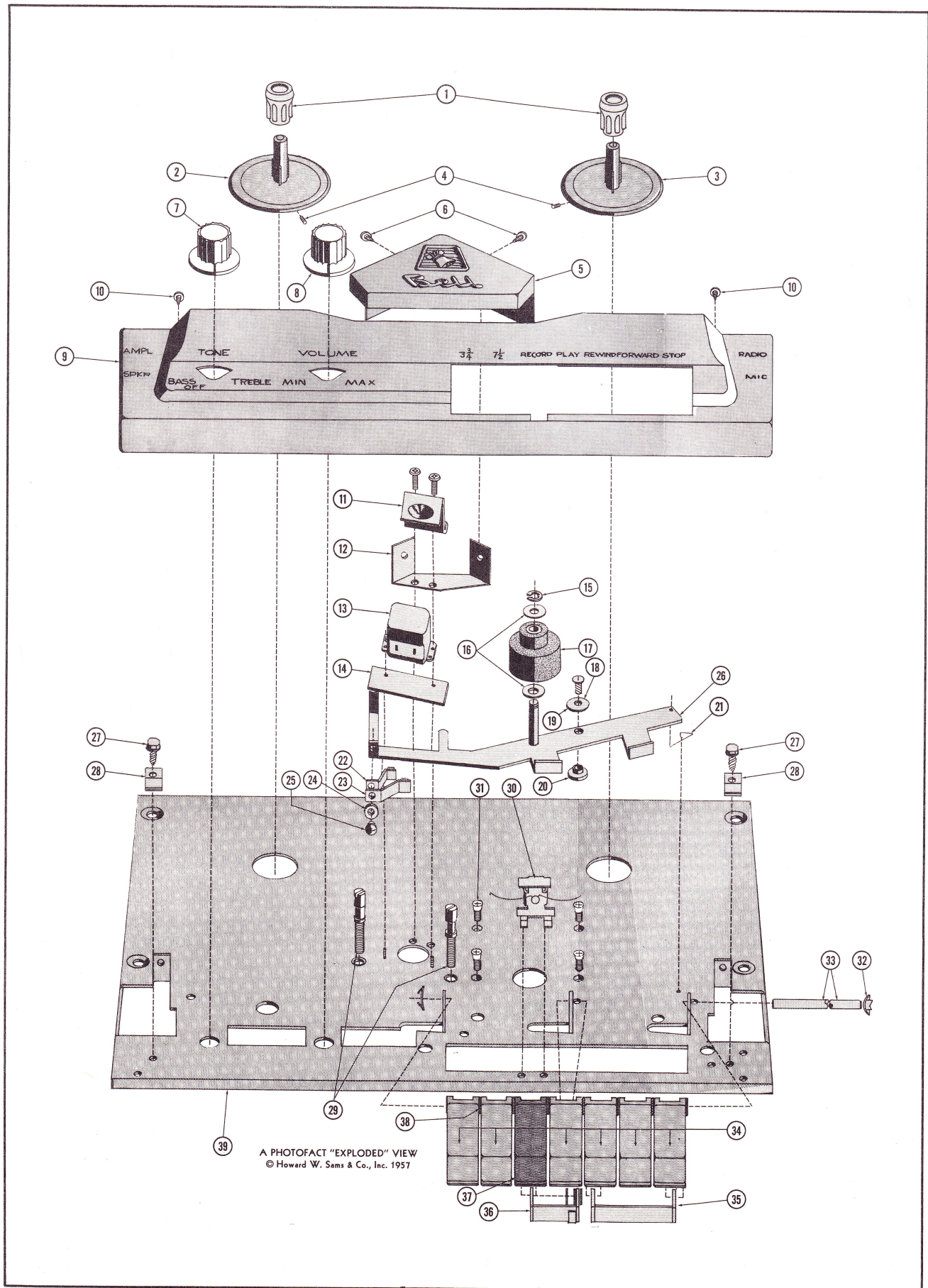
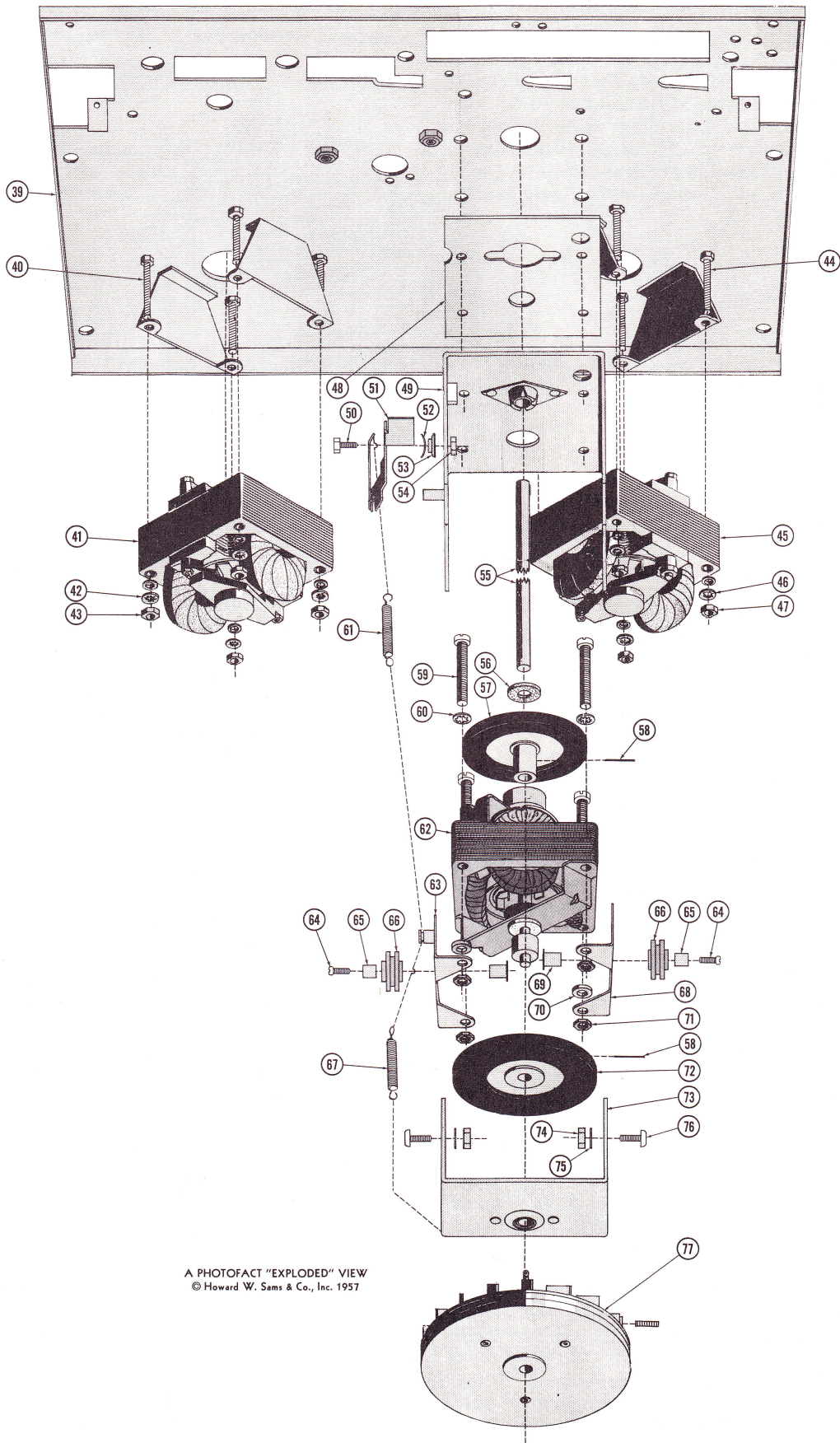

FIGURE 4A. EXPLODED VIEW OF PARTS ABOVE BASEPLATE.



A PHOTOFACIT "EXPLODED" VIEW
© Howard W. Sams & Co., Inc. 1957

FIGURE 4B. EXPLODED VIEW OF PARTS BELOW BASEPLATE.

CLEANING

The capstan shaft (portion extending above top deck plate), pressure roller (17), tape guides (29), and play-record-erase head (13) are subject to an accumulation of tape coating oxide which is worn off the tape as it passes these parts. These parts should be cleaned approximately every ten hours of running time. All of these parts except the pressure roller (17) may be cleaned with head cleaning solvent, alcohol, or

carbon tetrachloride. Use alcohol or water when cleaning the pressure roller; never use carbon tetrachloride when cleaning any rubber driving surface.

CAUTION: To prevent scratching the head pole pieces, never use a metal tool when cleaning the play-record-erase head (13).

LUBRICATION

Lubricants applied at time of manufacture are sufficient to last for a long period of time, but in case parts are replaced, or after each 1000 hours of operation — more or less, lubricate as follows:

1. Apply one drop of #10 motor oil to the top and bottom bearings of the take-up motor (45) and the rewind motor (41). An oiling hole is provided in each bearing holder casting.

2. Apply one drop of #10 motor oil to the top and bottom bearings of the capstan motor (62). Caution: After oiling this motor, be certain that no oil seeps onto the motor pulleys.

3. Apply one drop of #10 motor oil to the top and bottom capstan bearings. Caution: After oiling these bearings be certain that no oil seeps onto the rubber idlers (57 and 72) or onto the portion of the capstan shaft which extends above the top deck plate.

4. Apply one drop of #10 motor oil to the pressure roller bearing (17).

NOTE: Only a very small amount of oil is needed on each bearing. It is desirable to use too little rather than too much for less trouble is likely to result. Oil on the running surfaces between the motor pulleys and the rubber idlers is often a cause for poor or no drive as well as excessive wow and flutter.

TROUBLES AND REMEDIES

Poor Tape Drive In Play and Record —

Poor tape drive can be caused by:

1. Oil or grease on the driving surfaces of capstan drive wheel (57) and the upper pulley on the capstan motor (62). This will cause poor tape drive when operating in the 7 1/2 inch per second speed position.

2. Oil or grease on the driving surfaces of the capstan drive wheel (72) and the lower pulley on the capstan motor (62). This will cause poor tape drive when operating in the 3 3/4 inch per second speed position.

3. Oil, grease or tape coating oxide on the pressure roller (17) and the upper portion of the capstan shaft will cause poor tape drive in both the 3 3/4 and 7 1/2 inch per second speed position.

CAUTION: Use alcohol or water when cleaning rubber driving surfaces. Never use carbon tetrachloride when cleaning rubber parts.

4. Spring (67) disconnected or missing. If this spring is disconnected there will be no tape drive when operating the recorder in the 7 1/2 inch per second speed position. Replace spring (67).

5. Spring (61) disconnected or missing. If this spring is disconnected there will be no tape drive when

operating the recorder in the 3 3/4 inch per second speed position. Replace spring (61).

Take-Up Reel Will Not Take Up Tape In Play Or Record Position —

1. Set screw (4) in take-up reel platform (3) loose, causing the reel platform to slip on the motor shaft. Tighten the set screw.

2. Resistor (R26) open. Replace.

Recorder Will Not Rewind Tape —

1. Set screw (4) in supply reel platform (2) loose, causing the reel platform to slip on the rewind motor shaft. Tighten the set screw.

Dynamic Brakes Do Not Function Properly —

1. Check selenium rectifier (M1).

2. Check resistors (R25 and R27). If either of these resistors is open, there will be no hold-back tension on the rewind reel when in the "Play" or "Record" mode.

3. If, when going from "Rewind" to "Stop", tape spills from the take-up reel (3), check resistor (R25).

4. If, when going from "Fast Forward" to "Stop", tape spills from the rewind reel (2), check resistor (R27).

Normal DC voltages for selenium rectifier (M1) and motors (41) and (45) are as follows:

Selenium rectifier (M1), "Play" position — 30 volts DC.

Rewind motor (41), "Play or Record" — 8 volts DC.

Rewind motor (41) in "Stop" after "Play or Record" — 28 volts DC.

Take-up motor (45) in "Stop" after "Play or Record" — 17 volts DC.

AMPLIFIER TESTS AND REPAIRS

1. Check all tubes, inspect wiring and function switch (M5) for poor or open connections.

2. Test all four jacks for open or shorted circuits. These jacks must not ground against cover plate (9).

3. Refer to schematic for all voltage and resistance readings.

4. Test bias oscillator as follows: Connect a AC vacuum tube voltmeter across the erase head winding at the play-record-erase head socket. Due to high frequency, use unshielded wiring. Place recorder in "Record" position. Voltage should be 50 to 68 volts.

Check bias and erase frequency with a signal generator and scope. This should be 58 to 65 kc.

Check bias voltage across play-record head winding at the play-record-erase head socket.

A. 30 to 50 volts at 7 1/2 inches per second.

B. 10 to 17 volts at 3 3/4 inches per second.

5. The play-record-erase head may be tested for continuity if suspected of being open. The erase winding should be approximately 10 ohms and the play-record winding about 160 ohms.

CAUTION: Whenever the head is tested for continuity it will become magnetized to some extent. Therefore, always demagnetize head after testing.

ELECTRICAL PARTS LIST

Ref. No.	Part No.	Description	Ref. No.	Part No.	Description
V1		12AX7, Pre-Amp.	R10		Resistor, 4.7 meg., 1/2 Watt
V2		6SN7GT, Bias Osc.-AF Amp.	R11		Resistor, 470 K Ω , 1/2 Watt; $\pm 5\%$
V3		6V6GT, Audio Output	R12		Resistor, 470 K Ω , 1/2 Watt
V4		6X5GT, Rectifier	R13		Resistor, 33 K Ω , 1/2 Watt
C1A	B-20048P28	Cap., Elect., 20 mfd. @ 450 V.	R14		Resistor, 820 Ω , 1/2 Watt
C1B		Cap., Elect., 20 mfd. @ 450 V.	R15		Resistor, 7500 Ω , 1/2 Watt
C1C		Cap., Elect., 50 mfd. @ 50 V.	R16		Resistor, 1 meg., 1/2 Watt
C2A	B-20048P28	Cap., Elect., 20 mfd. @ 450 V.	R17		Resistor, 7500 Ω , 1/2 Watt; $\pm 5\%$
C2B		Cap., Elect., 20 mfd. @ 450 V.	R18		Resistor, 470 K Ω , 1/2 Watt
C2C		Cap., Elect., 50 mfd. @ 50 V.	R19		Resistor, 100 K Ω , 1/2 Watt
C3	B-20047P98	Cap., Molded Tub., .1 mfd. @ 200V.	R20		Resistor, 390 Ω , 1 Watt
C4	B-20047P14	Cap., Molded Tub., .0013 mfd. @ 400 V.	R21		Resistor, 2.2 meg., 1/2 Watt
C5	B-20141P1	Cap., Ceramic Disc, 10,000 mmf @ 500 V.	R22		Resistor, 270 K Ω , 1/2 Watt
C6	B-20047P81	Cap., Molded Tub., .05 mfd. @ 400 V.	R23		Resistor, 100 K Ω , 1/2 Watt
C7	B-20049P87	Cap., Mica, 470 mmf. @ 500 V.	R24	B-20256P18	Resistor, 6 Ω , 4 Watt
C8	B-20047P86	Cap., Molded Tub., .005 mfd. @ 400 V.	R25	B-20256P16	Resistor, 150 Ω , 5 Watt
C9	B-20047P81	Cap., Molded Tub., .05 mfd. @ 400 V.	R26	B-20256P17	Resistor, 200 Ω , 10 Watt
C10	B-20047P86	Cap., Molded Tub., .005 mfd. @ 400 V.	R27	B-20256P15	Resistor, 50 Ω , 5 Watt
C11	B-20047P17	Cap., Molded Tub., .002 mfd. @ 400 V.	R28		Resistor, 27 K Ω , 1/2 Watt
C12	B-20047P96	Cap., Molded Tub., .1 mfd. @ 400 V.	R29		Resistor, 10 K Ω , 1/2 Watt
C13	B-20049P98	Cap., Mica, 150 mmf. @ 500 V.	R30		Resistor, 470 Ω , 1 Watt
C14	B-20047P81	Cap., Molded Tub., .05 mfd. @ 400 V.	R31		Resistor, 470 Ω , 1 watt
C15	B-20049P87	Cap., Mica, 470 mmf. @ 500 V.	R32		Resistor, 27 Ω , 1/2 Watt
C16	B-20047P81	Cap., Molded Tub., .05 mfd. @ 400 V.	R33		Resistor, 47 K Ω , 1/2 Watt
C17	B-20047P17	Cap., Molded Tub., .002 mfd. @ 400 V.	T1	B-20366	Power Transformer
C18	B-20049P7	Cap., Mica, 100 mmf. @ 500 V.	T2	B-20352	Output Transformer
C19	B-20049P64	Cap., Mica, 270 mmf. @ 500 V.	SP1	B-20111P29	Speaker, P.M.; 5 1/4 inch Round
R1	B-20066P106	Volume Control, 1 meg.	L1	B-23704	Bias Osc. Coil
R2	B-20066P108	Tone Cont. and On-Off Switch, 500 K Ω	M1	B-20107-P10	Selenium Rectifier
R3	B-20066P72	Hum Adj. Cont., 100 Ω	M2	B-20043P31	Fuse, Pig-Tail - 3 Amp.GJV
R4		Resistor, 470K Ω , 1/2 Watt	M3		Pilot Lamp, #47
R5		Resistor, 1500 Ω , 1/2 Watt	M4		Neon Lamp, #NE-51
R6		Resistor, 10 K Ω , 1/2 Watt	M5	B-25251	Function Switch
R7		Resistor, 4.7 meg., 1/2 Watt	M6	A-25342	Leaf Switch, "Memory"
R8		Resistor, 68 K Ω , 1/2 Watt	M7	B-20209P30	Braking Switch
R9		Resistor, 4.7 meg., 1/2 Watt	M8	B-20209P20	Motor Socket, 9 Pin
			M9	B-20209P32	Head Socket, 4 Pin
			M10		Mic. Input Jack
			M11		Radio Input Jack
			M12	B-20209P32	Ext. Ampl. Output Jack
					Ext. Spkr. Output Jack

BELL SOUND
MODEL RT-204

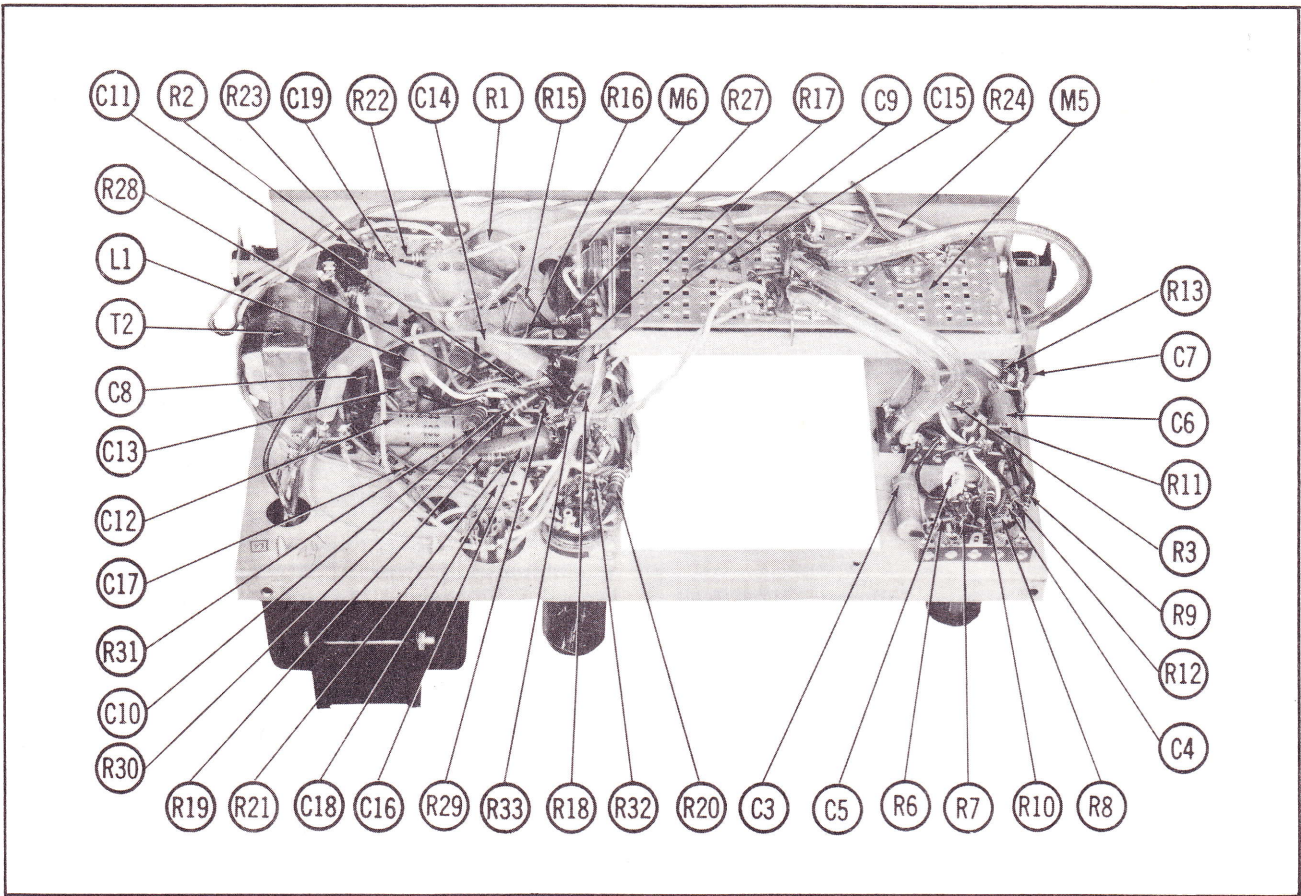

AMPLIFIER — FRONT VIEW

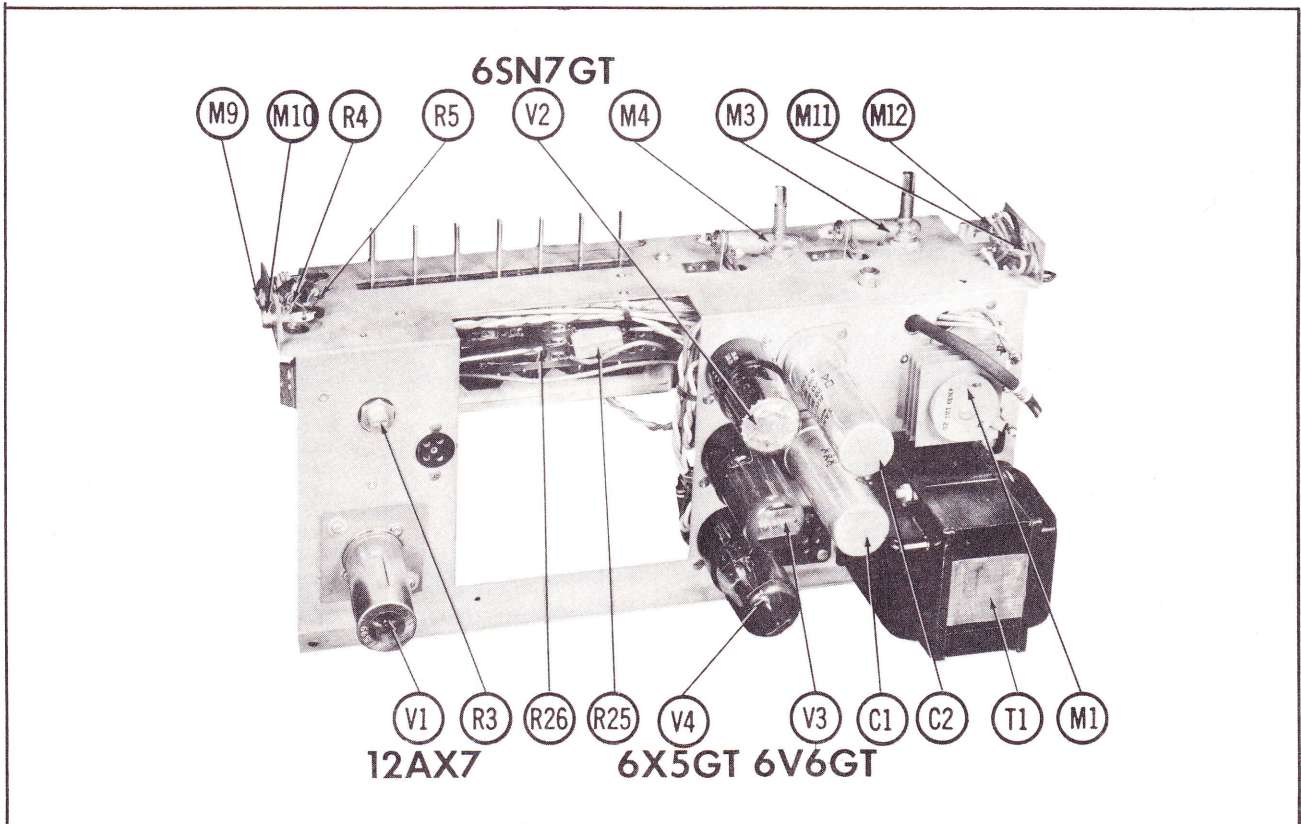

AMPLIFIER — REAR VIEW

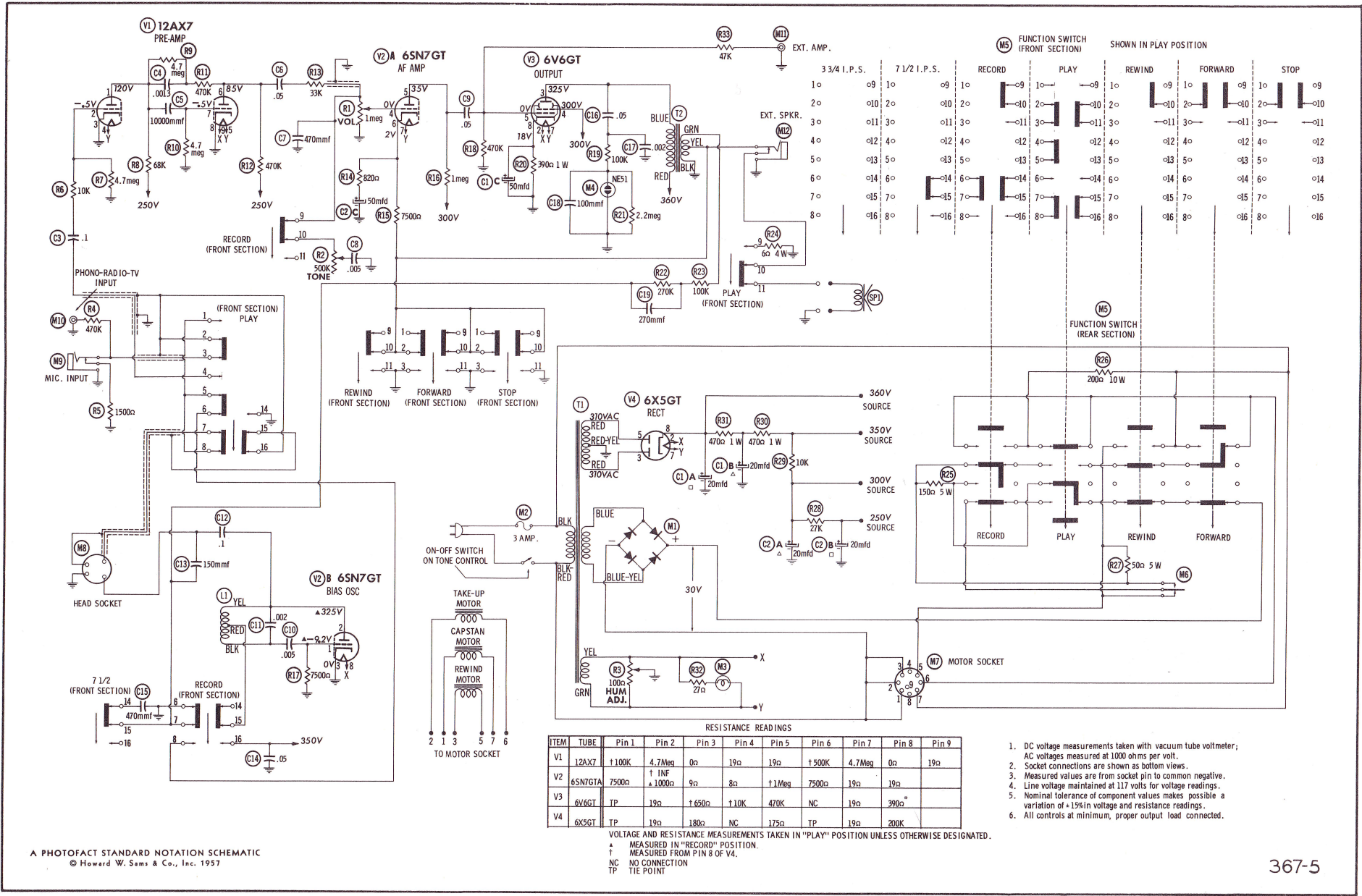

A PHOTOFAC STANDARD NOTATION SCHEMATIC
 © Howard W. Sams & Co., Inc. 1957

**BELL SOUND
 MODEL RT-204**

MECHANICAL PARTS LIST

Ref. No.	Part No.	Description	Ref. No.	Part No.	Description
1		#14 Crutch Tip, 1/4 I.D.	37	A-25268P2	Record Key (red)
2	A-25328	Reel Platform, Supply	38	B-20089P58	Fibre Washer (13 used)
3	A-25328	Reel Platform, Takeup	39	D-25340	Deck Plate Assembly
4		#8-32X 3/16 Set Screw, Bristol	40		#6-32 X 1 Hex. Hd. Mach. Screw
5	B-25292	Cup Point	41	B-25400P1	Rewind Motor
6		Head Cover	42		Lockwasher
7	B-20148P51	#6X1/4 Sheet Metal Screw	43		#6 Hex. Nut
8	B-20148P51	Tone Control On-Off Knob	44		#6-32X1 Hex. Hd. Mach. Screw
9	D-25291	Volume Control Knob	45	B-25400P2	Take-up Motor
10		Cover Plate	46		Lockwasher
11	A-25264	#6X 1/4 Sheet Metal Screw	47		#6 Hex. Nut
12	A-25319	Head Retaining Spring	48	A-25399	Gasket
13	B-23727P2	Head Cover Bracket	49		Motor and Capstan Mtg. Housing
14	A-25402	Play-Record-Erase Head	50		#6-32X1/4 Hex. Screw
15	A-23822	Head Plate	51	A-25394	Capstan Lever Weld Ass'y
16	A-23763P2	Retaining Ring	52		Spring Washer
17	A-23518P1	Nylon Washer	53		Shoulder Washer
18		Pressure Roller Assembly	54		#6 Hex. Nut.
19	B-20089P48	#6-32X1/4 Screw, Phillips	55	A-25389	Capstan Shaft
20	A-25315	Binder Head	56	B-20089-P26	Felt Washer
21	A-25270	Flat Washer	57	B-25386P1	Capstan Drive Wheel, 7 1/2 I.P.S.
22	B-25407	Slide Bearing	58		Roll Pin
23	A-25334P1	Pressure Roller Spring	59		#6-32X1 1/4 Rd. Hd. Mach. Scres
24	A-25331	Erase Pressure Pad Ass'y	60		Lockwasher
25		Record Pressure Pad Ass'y	61	A-25397P1	Motor Spring
26	B-25332	Felt Pad	62	B-25388	Capstan Motor Assembly
27		Lockwasher	63	A-25395	Capstan Motor Support Assembly
28		#6-32X1/4 Phillips Rd. Hd. Mach. Screw	64		6-32X3/8 Fil. Hd. Mach. Screw
29	A-25265	Pressure Roller Actuator Ass'y	65	B-20025P23	Spacer
30	A-25391	Hex. Hd. Self Tapping Screw	66	B-20029P41	Grommet
31		Cover Plate Retaining Clip	67	A-25397P2	Motor Spring
32		Tape Guides	68	A-25382	Capstan Motor Support
33	A-25269	Record Latch Ass'y	69		Eyelet
34	A-25268P1	#6-32X1/4 Phillips Flat Hd. Mach. Screw	70	A-25406	Motor Spacer
35		Tinnerman Push Nut	71		#6 Hex. Nut
36		Shaft	72	B-25386P2	Capstan Drive Wheel, 3 3/4 I.P.S.
		Key (6 used)	73	B-25381	Capstan Yoke
		Stop-Rewind-Forward Key	74		#8-32 Hex. Nut
		Actuator	75		Lockwasher
		Play-Record Key Actuator	76		#8-32X3/8 Phillips Hd. Mach. Screw
			77	A-25257	Flywheel Assembly