

EQ/140

Schematic

B I A M P[®]
S Y S T E M S

EQ/140 - TEST PROCEDURE

EQUIPMENT REQUIRED:

| | |
|--------------------|-------------------------------|
| Oscilloscope: | Tektronix 922 or Equivalent |
| Generator: | Tektronix FG507 or Equivalent |
| A C Voltmeter: | Tektronix DC502 or Equivalent |
| Frequency Counter: | Heath SM-4100 or Equivalent |

NOTE: Complete testing requires use of a log sweep generator

SET UP AND TEST PROCEDURE

+ 10 DBv 1500 cycle generator source. All frequency controls MAX counter clockwise.

Range #1 X1/X10 Switch IN, IN/OUT Switch OUT
"Q" to MAX clockwise position, -dB+ centered.

Range #2 X1/X10 Switch IN, IN/OUT Switch OUT
"Q" to MAX clockwise position, -dB+ centered.

Range #3 X1/X10 Switch IN, IN/OUT Switch OUT
"Q" to MAX clockwise position, -dB+ centered.

Range #4 X1/X10 Switch OUT, IN/OUT Switch OUT
"Q" to MAX clockwise position, -dB+ centered.

MASTER IN/OUT Switch OUT.

MASTER Level MIN at its counter clockwise position.

Connect the OUTPUT JACK to an A.C. Voltmeter and Oscilloscope.

The OUTPUT Level should be -10.5 DBv

Rotate the MASTER Level control to its MAX clockwise position.

The OUTPUT Level should be +12.2 DBv and the MASTER L.E.D. should be ON.

Rotate the MASTER Level Control until the +10 L.E.D. just comes ON. The knob should be pointing towards #7 on the scale.

Switch the MASTER IN/OUT Switch IN.

Set up and test procedure...continued

Reset the generator OUTPUT Level to "0" DBv.

Push the Range #1 IN/OUT Switch IN and rotate the -dB+ control to its MAX clockwise position.

Rotate the FREQ Control to where the OUTPUT Signal Level PEAKS. The reading should be about 150 (X10).

The PEAK OUTPUT Level should be about 17 DBv (± 1 DBv). The RED L.E.D. should come ON at about +10DBv. Rotate the -DB+ Control to its MAX counter clockwise position. The OUTPUT Level should be -17DBv(± 1 DBv). Return the -dB+ Control to "0" center and push the IN/OUT Switch OUT.

Push Range #2 IN/OUT Switch IN and rotate the -dB+ Control to its MAX clockwise position. Rotate the FREQ Control until the OUTPUT Signal Level PEAKS. The reading should be 150(X10). OUTPUT Level should be +17DBv(± 1 DBv). The +10DB L.E.D. should come ON at about +10DBv. Rotate the -dB+ Control to its MAX counter clockwise position BEFORE the Switch clicks. The OUTPUT Level should be -17DBv(± 1 DBv). Advance the -dB+ Control counter clockwise to "INFINITY". Carefully adjust the FREQUENCY CONTROL for MAXIMUM SIGNAL CUT. The attenuation should be -40DBv or GREATER. Return the -DB+ Control to "0" Center and push the IN/OUT Switch OUT.

Push the Range #3 IN/OUT Switch IN and rotate the -dB+ Control to its MAX Clockwise position. Rotate the FREQ Control for a PEAK in the OUTPUT Signal Level. The OUTPUT Level should be +17DBv(± 1 DBv). The reading should be 150 (X10) and the RED +10 L.E.D. should come on at about +10DBv. Rotate the -dB+ Control to its MAX counter clockwise Position BEFORE the Switch clicks. The OUTPUT Level should be -17DBv (± 1 DBv).

Set up and test procedure...continued

The OUTPUT attenuation should be -40DBv or GREATER. Return the -dB+ Control to "0" Center and push the IN/OUT Switch OUT.

Push the RAnge #4 IN/OUT Switch IN and rotate the -dB+ Control to its MAX clockwise position. Rotate the FREQ Control until the OUTPUT Level PEAKS. The reading should be about 1500 (X1). The OUTPUT Level should be +17DBv (± 1 DBv). The RED L.E.D. should come on at about +10DBv. Rotate the -dB+ Control to its MAX counter clockwise position. The OUTPUT Level should -17DBv (± 1 DBv). Return the -dB+ Control to "0" Center and push the IN/OUT Switch OUT.

"Q"ADJUST AND SHELING TEST

Log Sweep Generator, "0" DB Level from 20 HZ to 20KHZ.

First Filter: 20HZ to 2KHZ

Push the IN/OUT Switch IN, X1/X10 Switch OUT. Rotate the FREQUENCY Control full clockwise.

Set the -dB+ Control to its MAX clockwise position. Rotate the "Q" Control from MAX clockwise to MAX counter clockwise position. The bandwidth will spread out and the OUTPUT Level may increase. Return the "Q" Control to its clockwise position. Depress the X1/X10 Switch and the PEAK should shift position to the right on the scope display. Rotate the "Q" Control to "SHELF". The scope pattern should be HIGH on the LEFT SIDE of the scope display and taper down towards the RIGHT SIDE of the screen. Rotate the FREQ Control counter clockwise and the taper will level off closer to the LEFT side of the screen. Return -dB+ Control to "0" Center.

"Q" Adjust and Shelving Test...continued

Second Filter: 50HZ to 5KHZ

Repeat the First Filter procedure EXCEPT there is NO SHELF TEST.

Third Filter: 100 HA to 10KHZ

Repeat Second Filter procedure.

Fourth Filter: 200 HZ to 20KHZ

Repeat the procedure for the First Filter. The only difference being the Shelf Display will TAPER DOWN from the RIGHT, NOT the LEFT.

BALANCED OUTPUT

Transformer couple the output to the A C Voltmeter.
Adjust the output Level to "0" DBv.

Short separately Pin 2(T) and Pin 3(R) of the XLR OUTPUT connector to GROUND. The Output Level should NOT change.

Connect a balanced INPUT source to the INPUT SLR connector and note NORMAL OUTPUT.

NOISE MEASUREMENT

All Filter and Master IN/OUT Switches OUT. Master Level set at "7" on scale. Measure noise at 80 DBv below "0" reference.

All Filter Frequency, "Q", and -dB+ Controls set at center of rotation. Push all Filter and Master IN/OUT Switches IN. All range Switches OUT (X1).

NOISE should be 80DBv below "0" reference.

Noise Measurement...continued

All -dB+ Control to +16 clockwise and all Filter IN/OUT Switches OUT. Depress each Filter IN/OUT Switches IN INDIVIDUALLY. Noise should be at least 78 DBv below "0" reference.

Note: Lowest noise will be obtained with the top and bottom covers on the unit. BEWARE of excessive RADIATION from nearby equipment.

D

C

B

A

THIS DRAWING IS THE PROPERTY OF BIAMP SYSTEMS INC. AND MUST BE RETURNED TO THE OFFICE OF ORIGIN. IT IS NOT TO BE REPRODUCED OR TRANSMITTED IN ANY FORM OR BY ANY MEANS, ELECTRONIC OR MECHANICAL, INCLUDING PHOTOCOPYING, RECORDING, OR BY ANY INFORMATION STORAGE AND RETRIEVAL SYSTEM. THE RECIPIENT MUST BE PROTECTED AGAINST DISCLOSURE TO ANYONE EXCEPT THOSE EMPLOYEES WHO REQUIRE IT FOR THE WORK OR FOR THE REPAIR AND MAINTENANCE OF THE EQUIPMENT. THIS DRAWING IS NOT TO BE USED FOR UNAUTHORIZED USE OF THE INFORMATION CONTAINED HEREIN.

| PIN | DESCRIPTION |
|-----|-----------------|
| 1 | - INPUT |
| 2 | + INPUT |
| 3 | INPUT GROUND |
| 4 | N.C. |
| 5 | OUTPUT |
| 6 | PMR SUPPLY GND. |
| 7 | +15V DC REG |
| 8 | -15V DC REG |

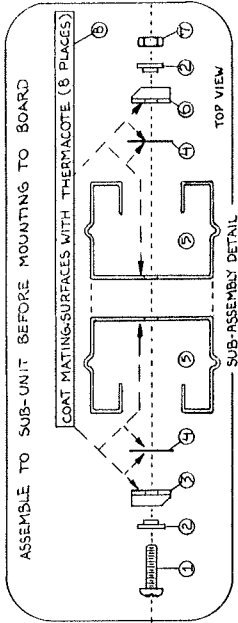

| DESCRIPTION | P/N | QTY |
|--|-------------|-----|
| 1. MACHINE SCREW #40-7/16 | 525-0002-00 | 1 |
| 2. SHOULDER WASHER #4 SW PLASTIC 7721-77PS | 540-0012 | 2 |
| 3. NEG. REGULATOR LM7915T (-15V) | 240-0004-00 | 1 |
| 4. MICA INSULATOR TG-220 CASE | 270-0010-00 | 2 |
| 5. HEATSINK | 350-0024-00 | 2 |
| 6. POS. REGULATOR LM 7815T (+15V) | 260-0006-00 | 1 |
| 7. #4-40 HEX NUT | 525-0012-00 | 1 |
| 8. THERMACOTE | 505-0003-00 | 1 |

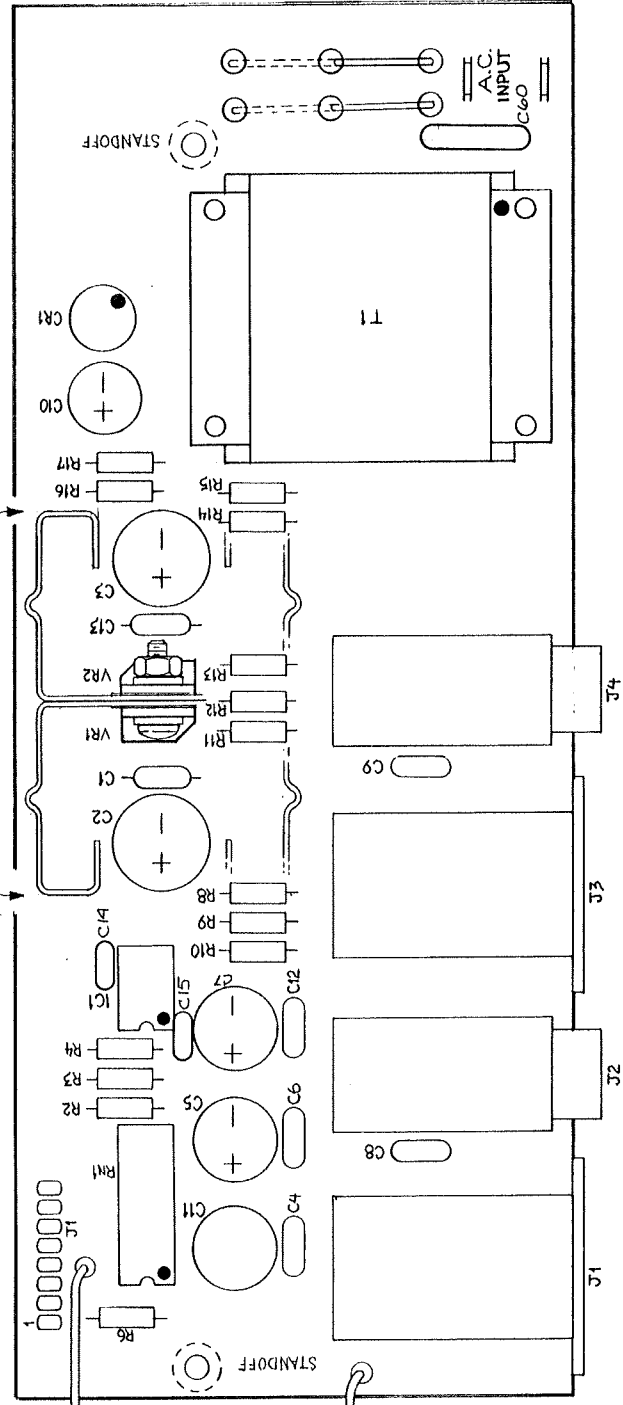

WIRE TO REAR PANEL TERMINAL BLOCK (#25-0004-00)

THIS DRAWING FOR USE WITH:
 PCB ARTWORK: 380-01E1-01 REV. C
 MASK LEVEL 2
 FAB DRAWING: 380-01E1-01 REV. C
 SCHEMATIC: 391-0003-00 REV. C

| | |
|----------|-------------|
| EG-140 | 391-0003-00 |
| ITEM | DESCRIPTION |
| PART NO. | SIZE |
| QTY. | QTY. |

| | |
|---|---|
| UNLESS OTHERWISE SPECIFIED, DIMENSIONS ARE IN INCHES. TOLERANCES ARE: DECIMALS FRACTIONS ANGLES PLATINES .XX ± .XXX ± | BIAMP SYSTEMS INC. COMPONENT ASSEMBLY IN / OUT PCB EG-140 PARAMETRIC EQUALIZER |
| MATERIAL | 841-0003-00 |
| FINISH | DO NOT SCALE DRAWING |
| MODEL | SCALE 2:1 |
| NEXT DWG. | SHEET 1 OF 2 |
| APPLICATION | SHEET 1 OF 2 |

D

C

B

A

| REV. | ECO. | CHANGE | DATE | BY |
|------|--------|-----------------|------|------|
| B | 10E-83 | CHANGED CIRCUIT | 4-83 | IKUR |
| C | 181-83 | ADD C14, C15 | 9-83 | MIVR |
| | | CHGD RES R11 | | |

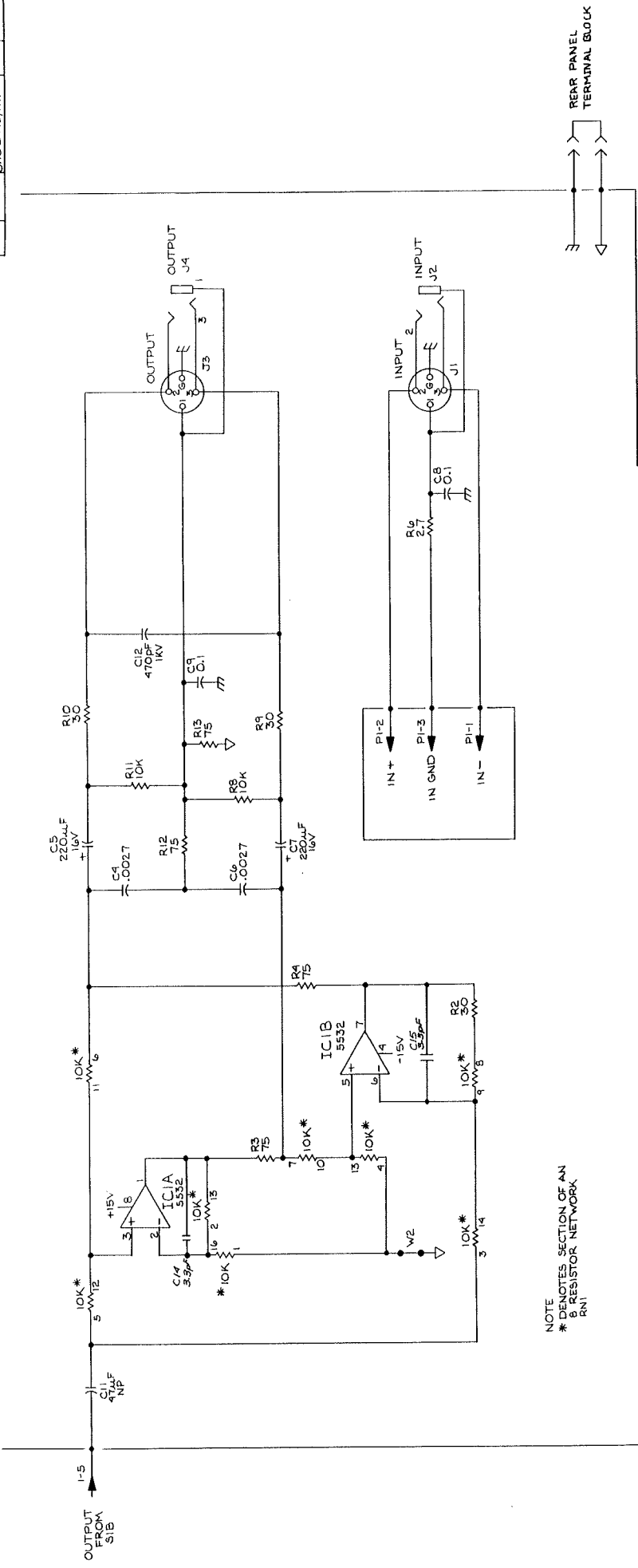

NOTE
* DENOTES SECTION OF AN
RNI

| HIGHEST REFERENCE DESIGNATIONS |
|--------------------------------|
| R 96 |
| C 60 |

BLAMP SYSTEMS
SCHEMATIC ASSEMBLY
EQ140 PARAMETRIC
B41-0003-00
REVISION C
DRAWN RC 2-85
CHECKED JD 2-85
APPROVED JM 3-85
PAGE 3 OF 3

REAR PANEL
TERMINAL BLOCK

A B C D E F G H

| | | |
|---------|-------|----|
| REV | DATE | BY |
| D 10283 | 4/783 | / |
| C 10763 | 4/63 | TR |

| | | |
|---------|-------|----|
| REV | DATE | BY |
| D 10283 | 4/783 | / |
| C 10763 | 4/63 | TR |

H

NOTES:
 1. THIS IS THE FIRST OF TWO PAGES OF THE COMPONENTS LIST FOR THIS BOARD.
 2. THE SECOND PAGE OF THIS LIST IS THE PIN ASSIGNMENT LIST.
 3. THE BOARD IS TO BE ASSEMBLED IN ACCORDANCE WITH THE BOARD LAYOUT AND THE COMPONENTS LIST.
 4. THE BOARD IS TO BE ASSEMBLED IN ACCORDANCE WITH THE BOARD LAYOUT AND THE COMPONENTS LIST.
 5. THE BOARD IS TO BE ASSEMBLED IN ACCORDANCE WITH THE BOARD LAYOUT AND THE COMPONENTS LIST.

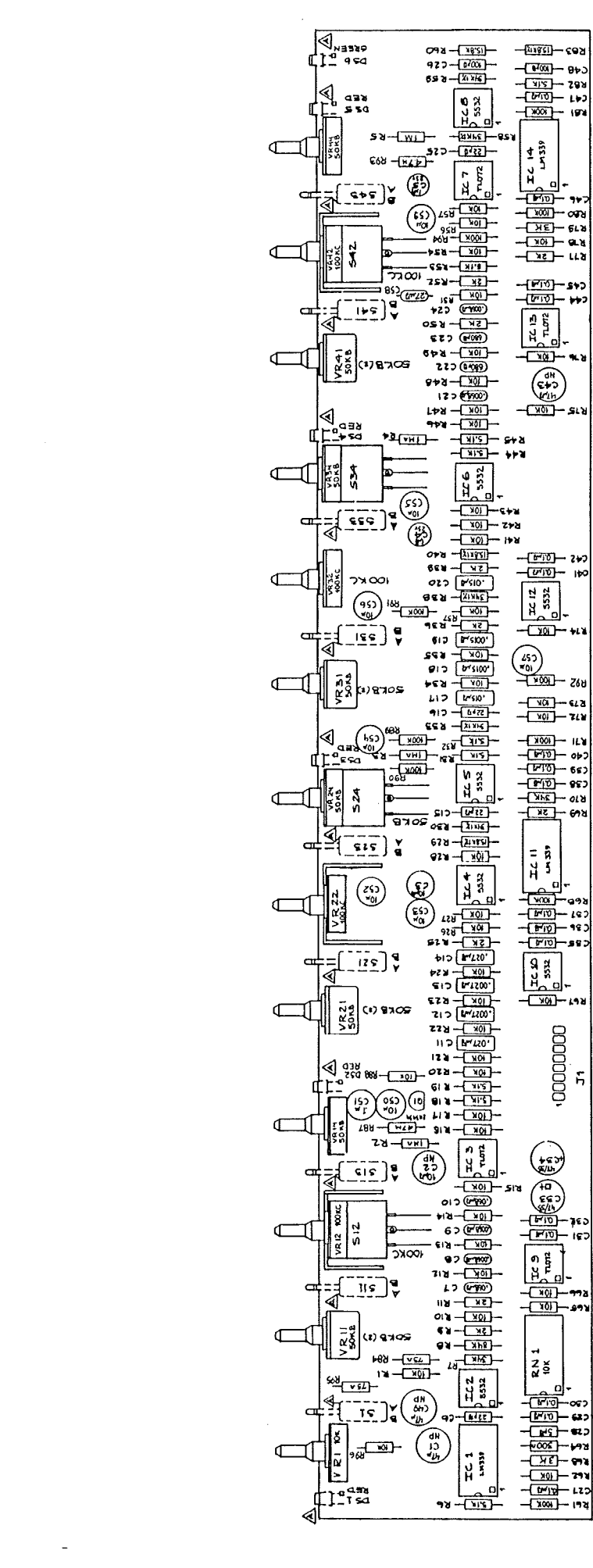

HIGHEST REFERENCE DISC.

| | |
|-----|-----|
| R86 | C40 |
|-----|-----|

PIN ASSIGNMENTS

| PIN | FUNCTION |
|-----|-----------|
| 1 | - INPUT |
| 2 | + INPUT |
| 3 | IN GND |
| 4 | N.C. |
| 5 | OUTPUT |
| 6 | PS GND |
| 7 | 15V REG |
| 8 | - 15V REG |

NOTES:
 1. SWITCHES AND LED'S MOUNT FROM POIL SIDE OF PCB.
 2. DO NOT FLOW SOLDER SWITCH WIRES ON THE BACK OF THE BOARD SOLDER IN MECH ASBY TO PREVENT POPPING.
 3. IF POTS ARE OUT OF ALIGNMENT.

| | | |
|---------|-------|----|
| REV | DATE | BY |
| D 10283 | 4/783 | / |
| C 10763 | 4/63 | TR |

| | | |
|---------|-------|----|
| REV | DATE | BY |
| D 10283 | 4/783 | / |
| C 10763 | 4/63 | TR |

A B C D E F G H

BIAMP SYSTEMS INC
 COMPONENT ASSEMBLY
 EQ 140 PCB
 REV. 1 OF 1

| REV. | E.C.O. | CHANGE | DATE | BY |
|------|--------|----------------|------|-----|
| B | 102-83 | CHGD CIRCUITRY | 6-83 | NVR |
| C | 181-83 | ADDED C14,C5 | 9-83 | MVR |
| | | CHGD R8,R11 | | |
| D | 197-83 | Δ R6,G3 & T9 | 9-83 | H2 |

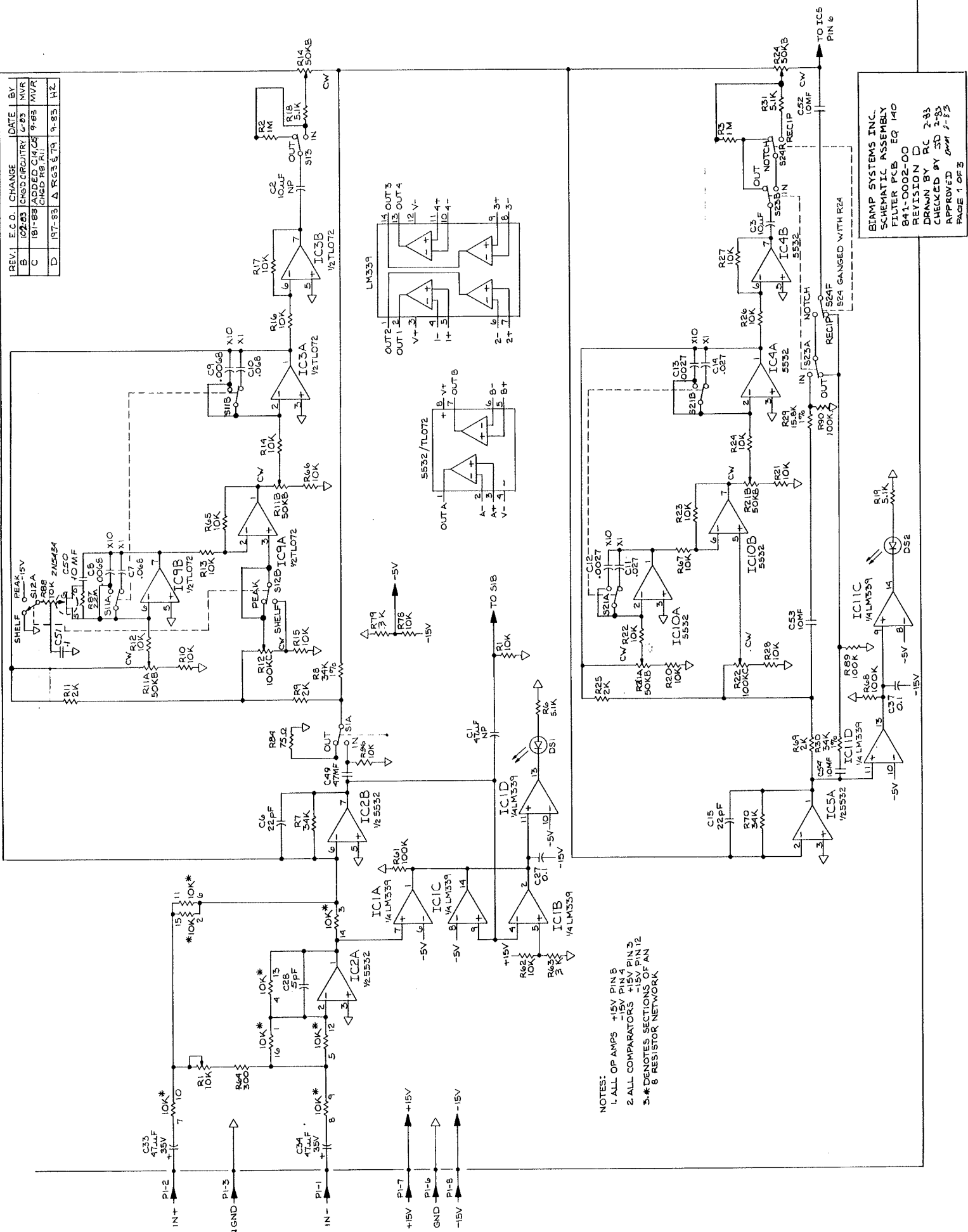

- NOTES:
- 1. ALL OP AMPS -15V PIN 8
 - 2. ALL COMPARATORS +15V PIN 3
 - 3. * DENOTES SECTIONS OF AN 8 RESISTOR NETWORK

BIAMP SYSTEMS INC.
 SCHEMATIC ASSEMBLY
 FILTER PCB EQ 140
 B41-0002-00
 REVISION D
 DRAWN BY RC 2-83
 CHECKED BY SD 2-83
 APPROVED *[Signature]* 2-83
 PAGE 1 OF 5

| | | | | |
|-----|----------|------------------|----|------|
| REV | DATE | DESCRIPTION | BY | CHKD |
| D | 10/28/83 | ADDED COMPONENTS | WJ | WJ |
| C | 10/28/83 | REVISED | WJ | WJ |

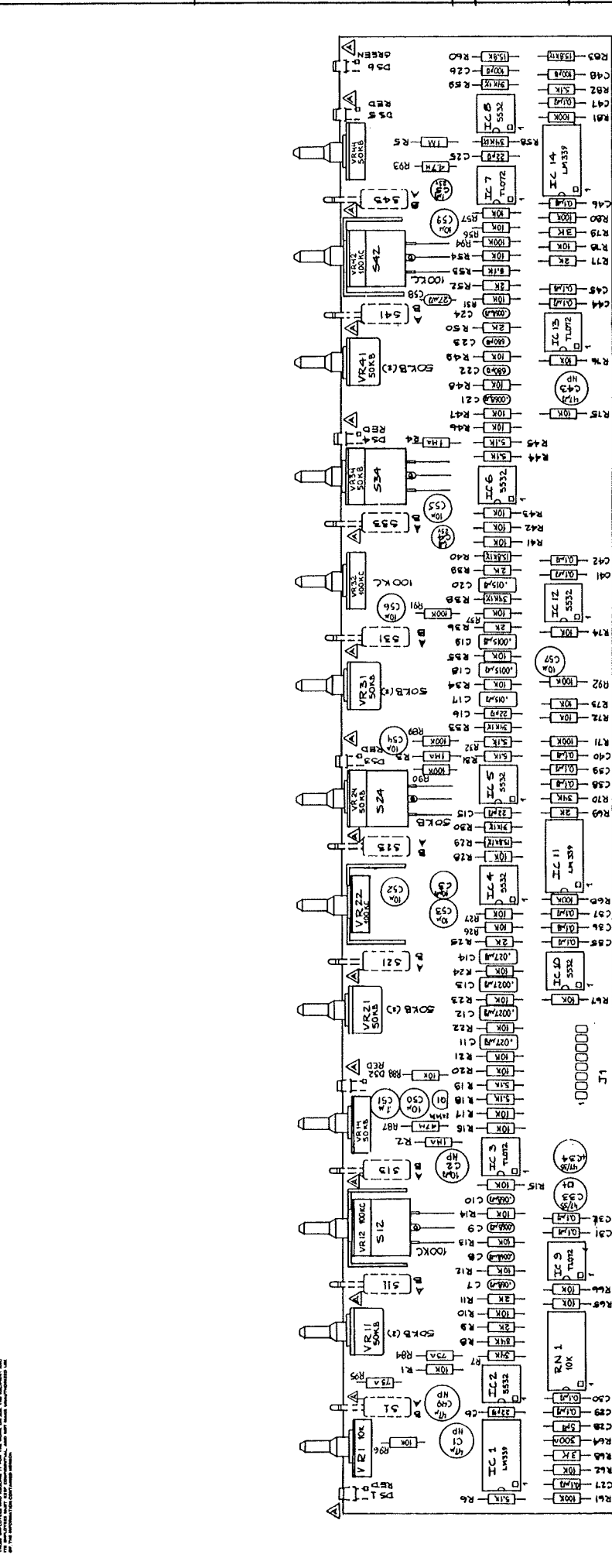

HIGHEST REFERENCE DESIG.
R86 C80

PIN ASSIGNMENTS

| PIN | FUNCTION |
|-----|------------|
| 1 | - INPUT |
| 2 | + INPUT |
| 3 | IN GND. |
| 4 | N.C. |
| 5 | OUTPUT |
| 6 | PK. GND |
| 7 | + 15V REG. |
| 8 | - 15V REG. |

NOTES
 Δ - SWITCHES AND LED'S MOUNT FROM
 REAR SIDE OF PCB
 Δ DO NOT FLOW SOLDER SWITCH WIRES ON THE
 BACK OF POTS. HAND SOLDER IN MECH. ASBY
 TO PREVENT POPPING A PAD OFF OF P.C.B.
 IF POTS ARE OUT OF ALIGNMENT.

| | | | | |
|----------|-----|--------------------|----|------|
| DATE | REV | DESCRIPTION | BY | CHKD |
| 10/28/83 | 1 | COMPONENT ASSEMBLY | WJ | WJ |
| 10/28/83 | 2 | EQ 14-D PCB | WJ | WJ |
| 10/28/83 | 3 | REVISED | WJ | WJ |

| | | | | |
|----------|-----|--------------------|----|------|
| DATE | REV | DESCRIPTION | BY | CHKD |
| 10/28/83 | 1 | COMPONENT ASSEMBLY | WJ | WJ |
| 10/28/83 | 2 | EQ 14-D PCB | WJ | WJ |
| 10/28/83 | 3 | REVISED | WJ | WJ |

| | | | | |
|----------|-----|--------------------|----|------|
| DATE | REV | DESCRIPTION | BY | CHKD |
| 10/28/83 | 1 | COMPONENT ASSEMBLY | WJ | WJ |
| 10/28/83 | 2 | EQ 14-D PCB | WJ | WJ |
| 10/28/83 | 3 | REVISED | WJ | WJ |

| REV. | ECO. | CHANGE | DATE | BY |
|------|--------|--------------------------------|------|-----|
| B | 102-83 | CHK'D CIRCUITRY | 6-83 | MWR |
| C | 187-83 | CHG'D R28, R17 ADDED C4, C5 | 7-83 | MWR |

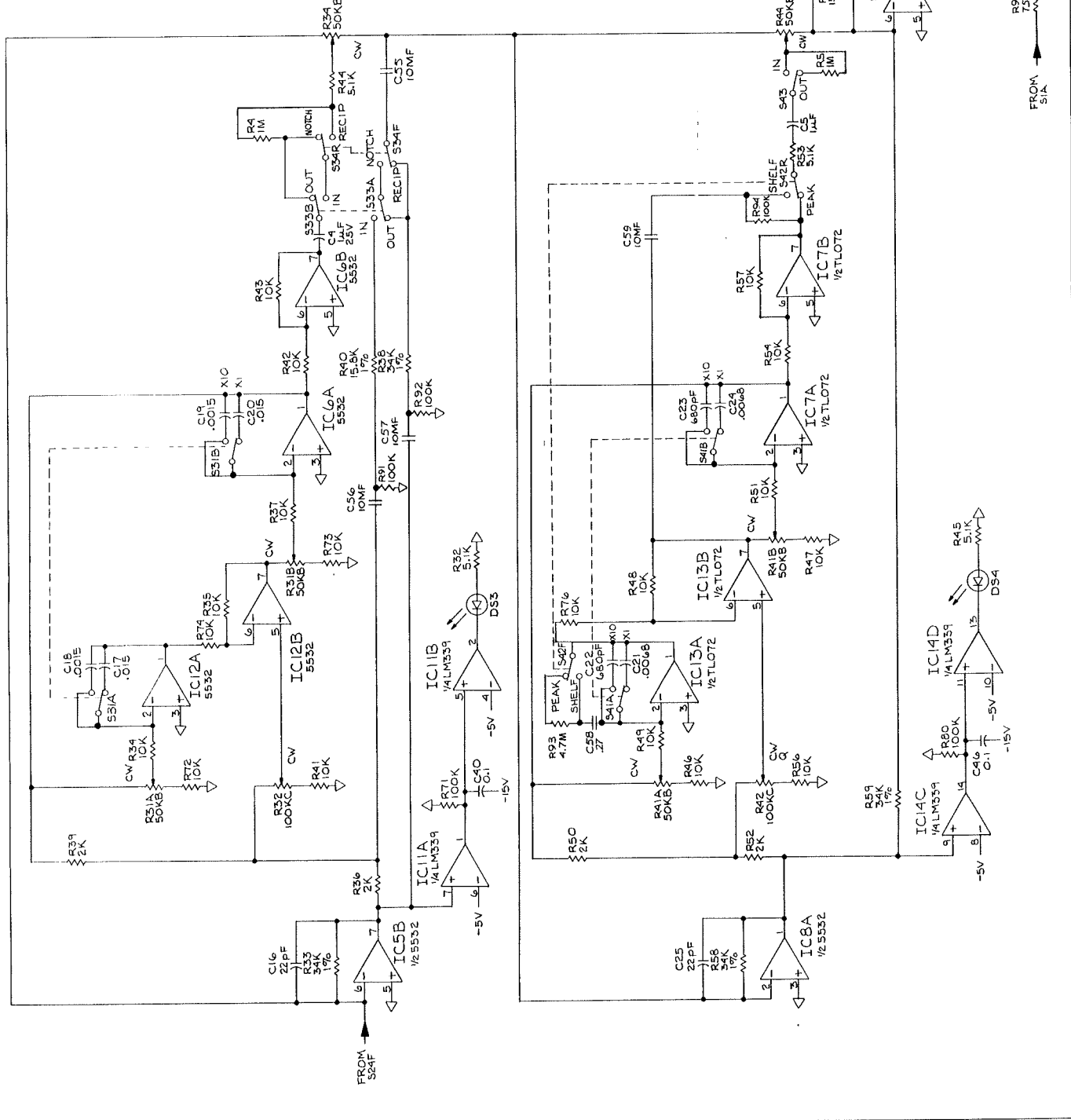
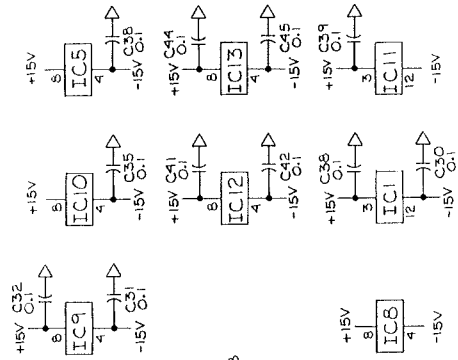
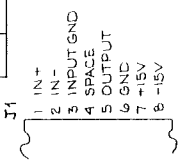

BIAMP SYSTEMS INC.
SCHEMATIC ASSEMBLY
FILTER PCB EQ 140
B41-0002-00
REV C

DRAWN RC 2-83
CHECKED JD 2-83
APPROVED DM 1-82
PAGE 2 OF 3

