



BEOCORD 1700 and 2200
TYPE 4603 and 4601



BANG & OLUFSEN A/S
DK - 7600 STRUER
DENMARK

TELEPHONE 07 - 65 11 22* - TELEX 66629
CABLE ADDRESS BANGOLUF

3538183

Kr. 8,00

PRINTED IN DENMARK
V/S EKSPRES-TRYKKERIET STRUER 27

Form. 7145

SERVICE MANUAL



CONTENTS	SECTION/PAGE
TECHNICAL DATA	1
DISASSEMBLY	2
Transistor chart	2-1
CIRCUIT DIAGRAM, PC-BOARDS AND PARTS LIST	3
Transistor chart	3-1
PC-boards	3-2
Circuit diagram	3-3
Parts list	3-6
ADJUSTMENT	4
<u>Electrical</u>	4-1
30 V	4-1
Current limiter	4-1
Azimuth	4-1
Playback level	4-1
VU meter	4-2
Erase oscillator	4-2
Filter for bias	4-2
Recording level	4-3
Bias	4-3
Playback frequency response	4-4
Record/playback frequency response	4-4
AF record current, CrO ₂	4-4
Checking distortion (CrO ₂)	4-4
Bias Fe ₂ O ₃	4-5
Record current, Fe ₂ O ₃	4-5
Checking distortion (Fe ₂ O ₃)	4-5
Speed adjustment	4-5
<u>Dolby</u>	4-6
19 kHz filter	4-6
System and gain	4-6
Playback check	4-6
<u>Mechanical functions and adjustments</u>	4-7
Normal forward tape motion	4-7
Record	4-7
Record protection	4-8
Pause	4-8
Fast rewind	4-9
Fast forward	4-9
Stop	4-10
Eject	4-10
Magnet coil (automatic stop)	4-10
Lubrication	4-11
PARTS LIST	5
SERVICE TIPS	6
Removal of push-button system	6-1
Push-button system blocking	6-1
Pressure-wheel	6-1
Mounting of cover plate	6-2
Dolby	6-2
MODIFICATIONS	7
Fast forward/rewind	7-1
Static electricity	7-1
Broken tape	7-2
Flywheel	7-2

TECHNICAL DATA

Subject to change without notice

		BEOCORD 2200 Dolby Type 4601	BEOCORD 1700 Type 4603
Tape system	Compact Cassette	C 60 - C 90	C 60 - C 90
Tape type	Low noise	Yes	Yes
	Chromium dioxide, CrO ₂	Yes	Yes
Dolby system	Built-in or prepared	Built-in	Prepared
Tape head	Type	Ferrite	Ferrite
Recording control	Left and right channels	Separate	Separate
VU meter	Indicator system	Two VU meters	Two VU meters
Automatic stop	Stop at end of tape	Yes	Yes
Counter	Number of digits	Three digits	Three digits
Memory	Automatic stop at 000	Yes	Yes
Microphone	Mono/stereo socket	Yes	Yes
AUX	Socket for copying	Yes	Yes
Headphones	Jack socket	Yes	Yes
Wow and flutter	JIS	< ± 0.12 %	< ± 0.12 %
Speed Deviation	DIN 45 500	< ± 1.5 %	< ± 1.5 %
Fast Forward and Rewind	C 60	70 sec.	70 sec.
Frequency Range	DIN 45 500	30 - 14,500 Hz	30 - 14,500 Hz
Signal - to noise Ratio	DIN 45 500, Chromium dioxide	> 52 dB	> 52 dB
	Dolby, Chromium dioxide	> 61 dB	
Erase	DIN 45 500	> 70 dB	> 70 dB
Erase Frequency		80 kHz	80 kHz
Inputs	Sensitivity, VU 0 dB, 1000 Hz	4 - 400 mV/47 kohm	4 - 400 mV/47 kohm
	Microphone	0.1 - 1 mV/1 kohm	0.1 - 1 mV/1 kohm
	AUX	0.2 - 20 V/2.2 Mohm	0.2 - 20 V/2.2 Mohm
Outputs	Signal voltage, 1000 Hz	660 mV/6.3 kohm	660 mV/6.3 kohm
	Headphones	0.5 - 0.8 mW	0.5 - 0.8 mW
Dimensions	H X W X D	7.5 X 50 X 23 cm	7.5 X 50 X 23 cm

PC 8004119, DOLBY

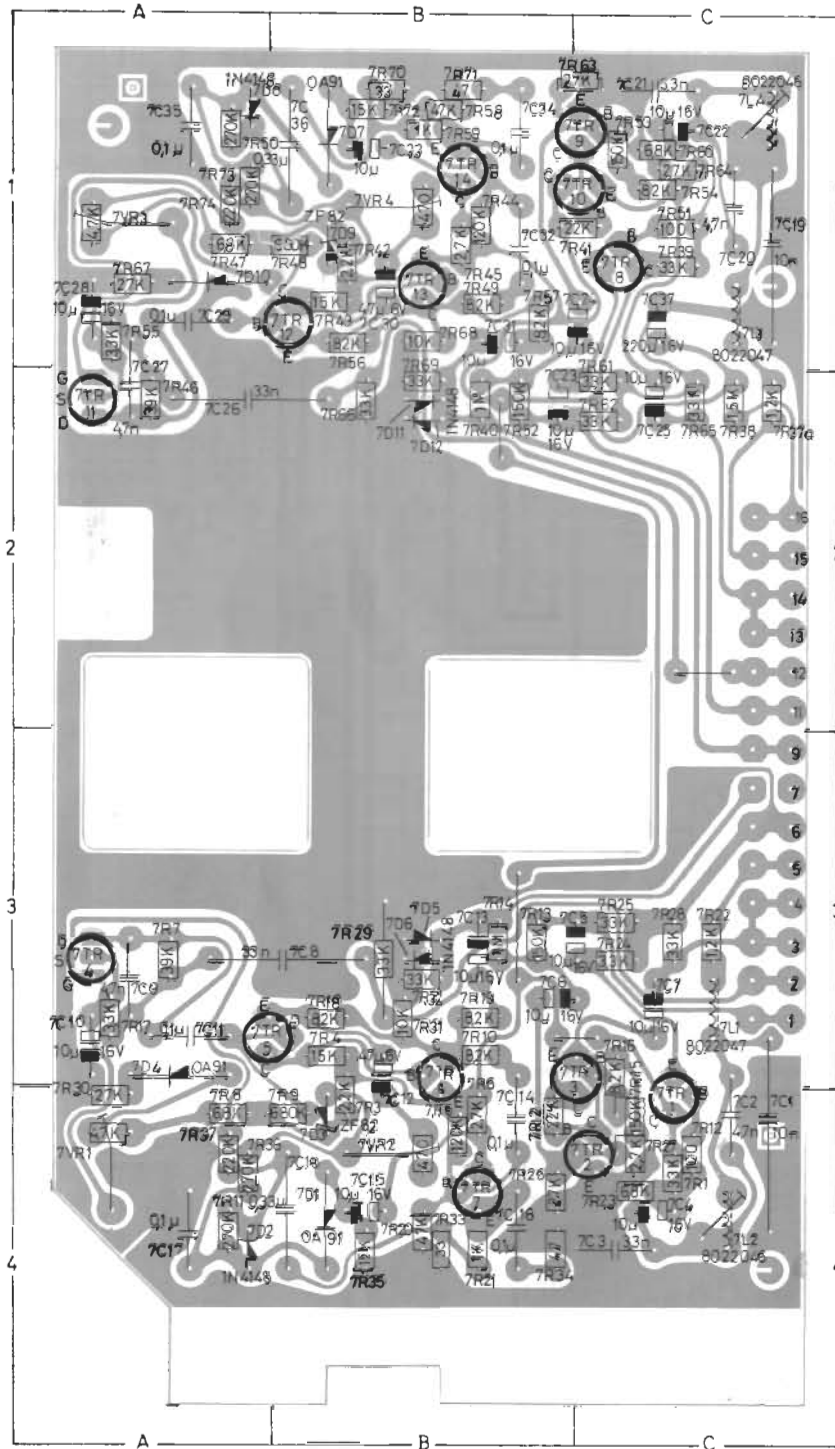

PC PLADE SET FRA PRINTSIDE / SEEN FROM CONDUCTOR SIDE / PRINTPLATE VON DER LEITERSEITE AUS GEGEHEN

DIAGRAM 1

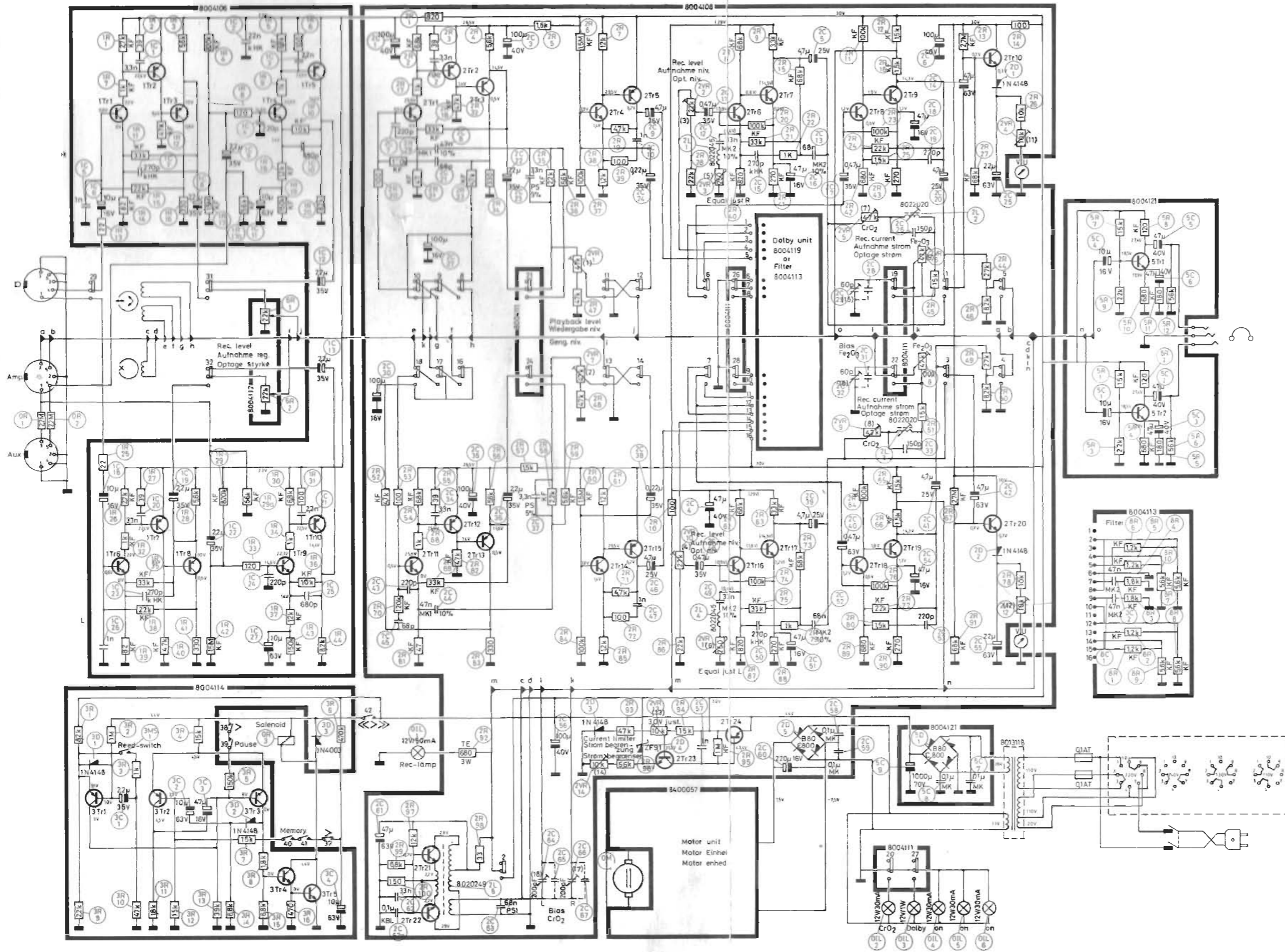

PC 8004106, FORFORSTÆRKER / PRE-AMPLIFIER /
VORVERSTÄRKER

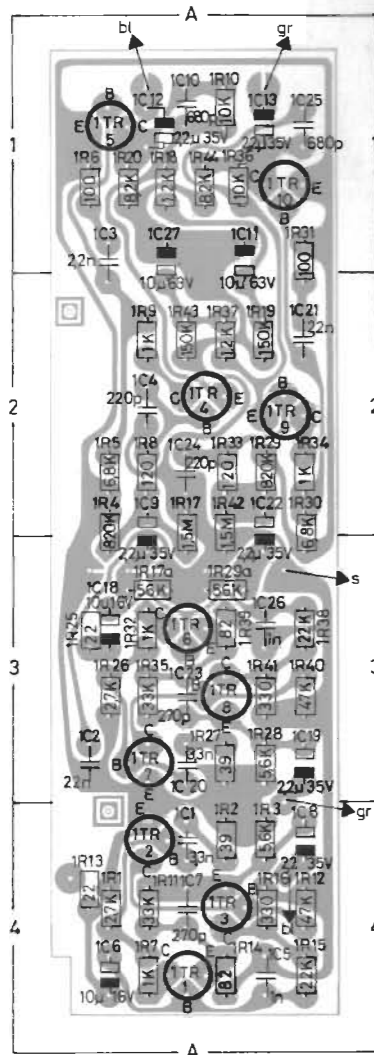

PC 8004108, OPTAGE- GENGIVE FORSTÆRKER / RECORD - PLAYBACK / AUFNAHME - WIEDERGABE

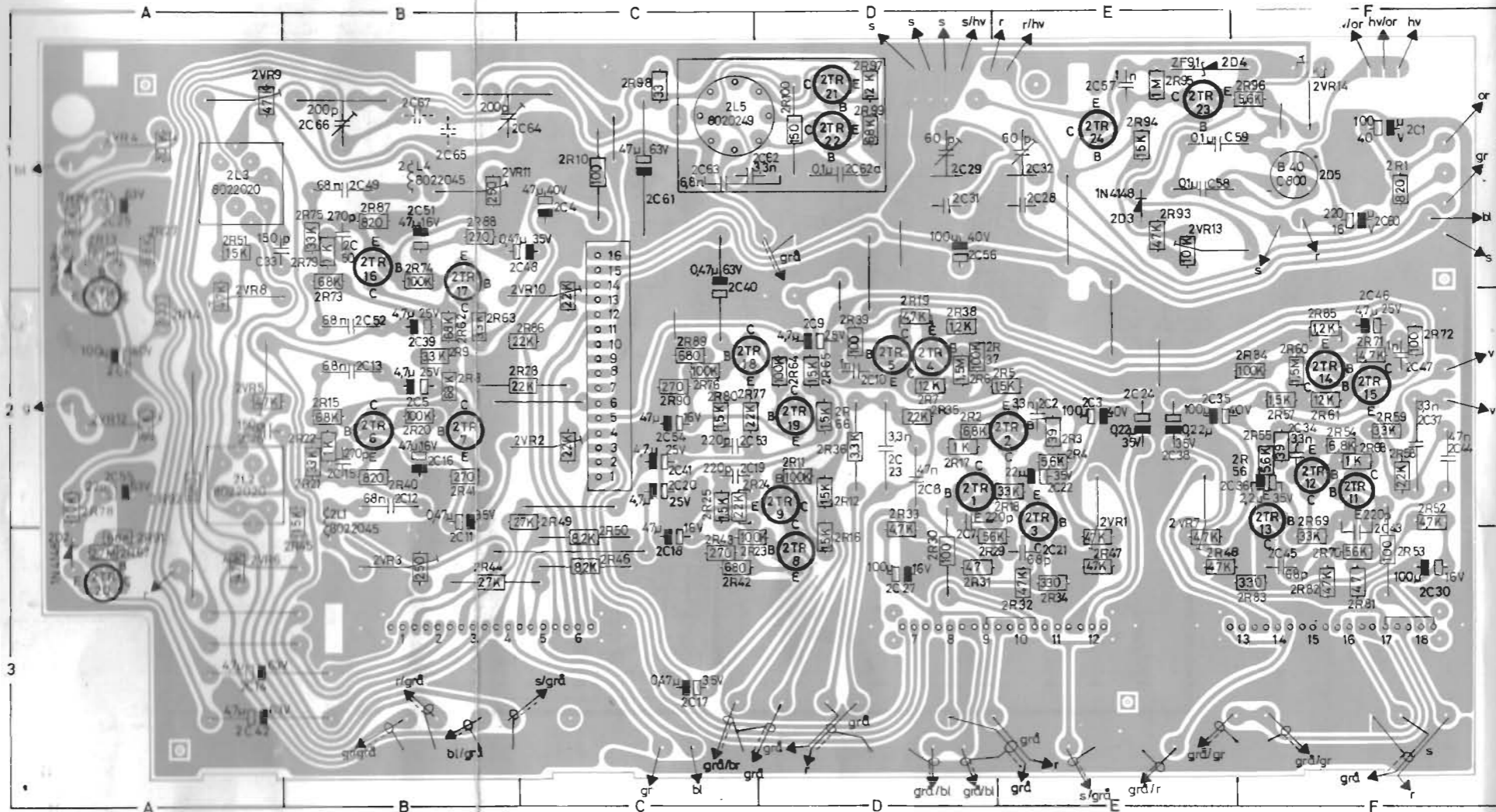

PC 8004121, HOVEDTELEFONFORSTÆRKER / HEADPHONE AMPLIFIER
KOPFHÖRER-VERSTÄRKER

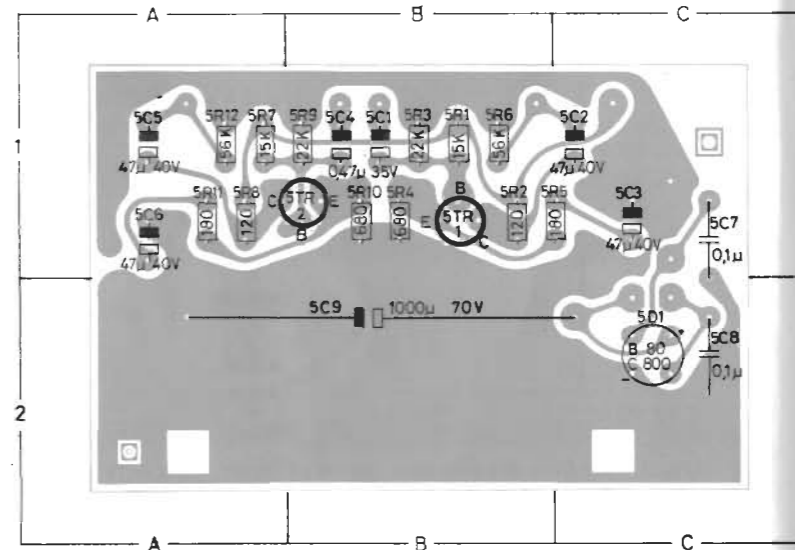

PC 8004114, AUTOSTOP

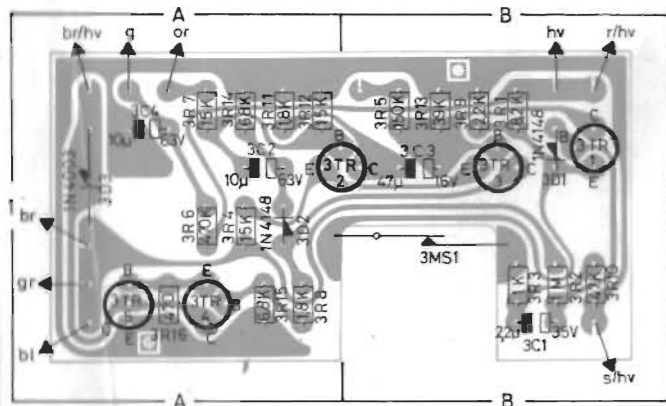

PC 8004115

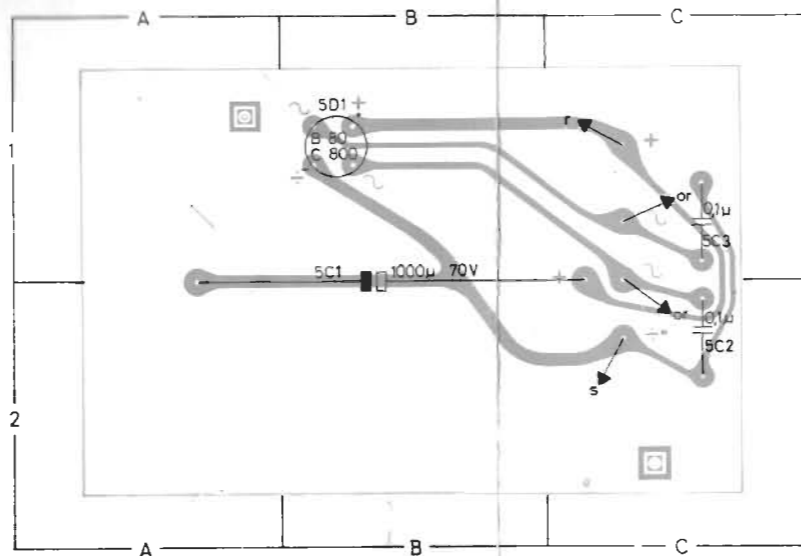

PC 8004112, POTENTIOMETER / CONTROLS / REGLER

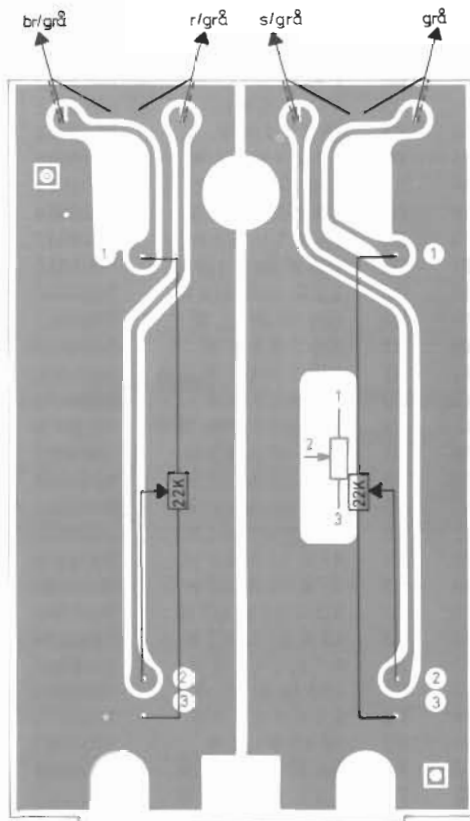

PC 8004113, FILTER

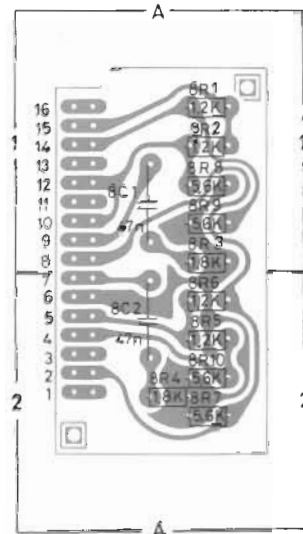

PC PLADER SET FRA PRINTSIDE / SEEN FROM CONDUCTOR SIDE / PRINTPLATE VON DER LEITERSEITE AUS Gesehen

1 PC 8004106

Component	Value	Power	Part No.
1TR1	A4 8320139		
1TR2	A4 8320069		
1TR3	A4 8320069		
1TR4	A3 8320095		
1TR5	A1 8320069		
1TR6	A3 8320139		
1TR7	A3 8320069		
1TR8	A3 8320069		
1TR9	A2 8320095		
1TR10	A1 8320069		
1R1	A4 2,7 K 5 % 1/8 W	5010298	
1R2	A4 39 10 % 1/2 W	5010007	
1R3	A4 5,6 K 10 % 1/2 W	5001039	
1R4	A2 820 K 5 % 1/4 W	5011068	
1R5	A2 6,8 K 5 % 1/8 W	5010052	
1R6	A1 100 10 % 1/2 W	5001013	
1R7	A4 1 K 5 % 1/8 W	5010040	
1R8	A2 120 10 % 1/8 W	5001015	
1R9	A2 1K 10 % 1/2 W	5001029	
1R10	A1 10 K 5 % 1/8 W	5010059	
1R11	A4 33 K 5 % 1/8 W	5010075	
1R12	A4 47 K 5 % 1/8 W	5010045	
1R13	A4 22 10 % 1/2 W	5001004	
1R14	A4 82 5 % 1/8 W	5010056	
1R15	A4 22 K 5 % 1/8 W	5010079	
1R16	A4 330 10 % 1/2 W	5001021	
1R17	A2 1,5 M 10 % 1/4 W	5011071	
1R17a	A3 56 K 5 % 1/8 W	5010061	
1R18	A1 1,2 K 5 % 1/8 W	5010153	
1R19	A2 150 K 5 % 1/8 W	5010063	
1R20	A1 8,2 K 10 % 1/2 W	5001041	

1R25	A3 22 10 % 1/2 W	5001004
1R26	A3 2,7 K 5 % 1/8 W	5010298
1R27	A3 39 10 % 1/2 W	5001007
1R28	A3 5,6 K 10 % 1/2 W	5001039
1R29	A2 820 K 5 % 1/4 W	5011068
1R29a	A3 56 K 5 % 1/8 W	5010061
1R30	A2 6,8 K 5 % 1/8 W	5010052
1R31	A1 100 10 % 1/2 W	5001013
1R32	A3 1 K 5 % 1/8 W	5010040
1R33	A2 120 10 % 1/2 W	5001015
1R34	A2 1 K 10 % 1/2 W	5001029
1R35	A3 33 K 5 % 1/8 W	5010075
1R36	A1 10 K 5 % 1/8 W	5010059
1R37	A2 1,2 K 5 % 1/8 W	5010153
1R38	A3 22 K 5 % 1/8 W	5010079
1R39	A3 82 5 % 1/8 W	5010056
1R40	A3 47 K 5 % 1/8 W	5010045
1R41	A3 330 10 % 1/2 W	5001021
1R42	A2 1,5 M 10 % 1/4 W	5011071
1R43	A2 150 K 5 % 1/8 W	5010063
1R44	A1 8,2 K 10 % 1/2 W	5001041

1C1	A4 3,3 nF 10 % 100 V	4011025
1C2	A3 22 nF 40 V	4010060
1C3	A1 2,2 nF 10 % 63 V	4010061
1C4	A2 220 pF 10 % 100 V	4010021
1C5	A4 1 nF 10 % 100 V	4010027
1C6	A4 10 µF 16 V	4200101
1C7	A4 270 pF 10 % 100 V	4000013
1C8	A4 2,2 µF 35 V	4201069
1C9	A2 2,2 µF 35 V	4201069
1C10	A1 680 pF 10 % 100 V	4010031
1C11	A1 10 µF 63 V	4201065
1C12	A1 2,2 µF 35 V	4201069
1C13	A1 2,2 µF 35 V	4201069

1C18	A3	10 µF 16 V	4200101
1C19	A3	2,2 µF 35 V	4201069
1C20	A3	3,3 nF 10 % 100 V	4011025
1C21	A2	2,2 nF 10 % 63 V	4010061
1C22	A2	2,2 µF 35 V	4201069
1C23	A3	270 pF 10 % 100 V	4000013
1C24	A2	220 pF 10 % 100 V	4010021
1C25	A1	680 pF 10 % 100 V	4010031
1C26	A3	1 nF 10 % 100 V	4010027
1C27	A1	10 µF 63 V	4201065

2 PC 8004108



2TR1	D2	8320139	
2TR2	E2	8320069	
2TR3	E2	8320069	
2TR4	D2	8320097	
2TR5	D2	8320161	
2TR6	B2	8320097	
3TR7	B2	8320097	
2TR8	D3	8320097	
2TR9	D2	8320097	
2TR10	A2	8320285	
2TR11	F2	8320139	
2TR12	F2	8320069	
2TR13	F2	8320069	
2TR14	F2	8320097	
2TR15	F2	8320161	
2TR16	B2	8320097	
2TR17	B2	8320097	
2TR18	C2	8320097	
2TR19	D2	8320097	
2TR20	A3	8320285	
2TR21	D1	8320137	
2TR22	D1	8320137	
2TR23	E1	8320097	
2TR24	E1	8320241	

2D1	A1	1N 4148, SFD 184	8300058
2D2	A3	1N 4148, SFD 184	8300058
2D3	E1	1N 4148, SFD 184	8300058
2D4	E1	ZPD 9,1 V, C9V1	8300028
2D5	F1	B40 C 800	8300155

2R1	F1	820 10 % 1/2 W	5001027
2R2	D2	6,8 K 5 % 1/8 W	5010052
2R3	E2	39 10 % 1/2 W	5001007
2R4	E2	5,6 K 10 % 1/2 W	5001039
2R5	E2	1,5 K 10 % 1/2 W	5001032
2R6	D2	1,5 M 10 % 1/8 W	5010093
2R7	D2	12 K 10 % 1/2 W	5001043
2R8	B2	68 K 5 % 1/8 W	5010062
2R9	B2	3,3 K 5 % 1/8 W	5010076
2R10	C1	100 10 % 1/2 W	5001013
2R11	D2	100 k 5 % 1/8 W	5010049
2R12	D2	1,5 K 5 % 1/8 W	5010247
2R13	A1	2,7 M 5 % 1/8 W	5010431
2R14	A2	100 10 % 1/2 W	5001013
2R15	B2	68 K 5 % 1/8 W	5010062
2R16	D3	1,5 K 5 % 1/8 W	5010247
2R17	D2	1 K 10 % 1/2 W	5001029
2R18	E2	33 K 5 % 1/8 W	5010075
2R19	D2	4,7 K 5 % 1/8 W	5010048
2R20	B2	100 K 10 % 1/2 W	5001055
2R21	B2	33 K 5 % 1/8 W	5010075
2R22	B2	1 K 10 % 1/2 W	5001029
2R23	C3	100 k 10 % 1/2 W	5001055
2R24	C2	2,2 K 5 % 1/8 W	5010079
2R25	C2	1,5 K 10 % 1/2 W	5001032

2R26	A1	10 k 10 % 1/2 W	5001042
2R27	A1	68 K 5 % 1/8 W	5010062
2R28	C2	22 K 10 % 1/2 W	5001046
2R29	D3	120 K 5 % 1/8 W	5010047
2R30	D3	100 10 % 1/2 W	5001013
2R31	D3	47 5 % 1/8 W	5010411
2R32	E3	47 5 % 1/8 W	5010411
2R33	D2	4,7 K 5 % 1/8 W	5010048
2R34	E3	330 10 % 1/2 W	5001021
2R35	D2	2,2 K 5 % 1/8 W	5010064
2R36	D2	5,6 K 5 % 1/8 W	5010041
2R37	D2	100 K 10 % 1/2 W	5001055
2R38	D2	1,2 K 10 % 1/2 W	5001030
2R39	D2	100 10 % 1/2 W	5001013
2R40	B2	820 5 % 1/8 W	5010068
2R41	B2	270 5 % 1/8 W	5010000
2R42	C3	680 5 % 1/8 W	5010144
2R43	C3	270 5 % 1/8 W	5010000
2R44	B3	27 K 10 % 1/2 W	5001047
2R45	B3	15 K 10 % 1/2 W	5001044
2R46	C3	82 K 10 % 1/2 W	5001041
2R47	E3	47 K 10 % 1/2 W	5001050
2R48	E3	47 K 10 % 1/2 W	5001050
2R49	C2	27 K 10 % 1/2 W	5001047
2R50	C3	8,2 K 10 % 1/2 W	5001041
2R51	A1	15 K 10 % 1/2 W	5001044
2R52	F2	4,7 K 5 % 1/8 W	5010048
2R53	F3	100 10 % 1/2 W	5001013
2R54	F2	6,8 K 5 % 1/8 W	5010052
2R55	F2	39 10 % 1/2 W	5001007
2R56	F2	5,6 K 10 % 1/2 W	5001039
2R57	F2	1,5 K 10 % 1/2 W	5001032
2R58	F2	2,2 K 5 % 1/8 W	5010064
2R59	F2	5,6 K 5 % 1/8 W	5010041
2R60	F2	1,5 M 5 % 1/8 W	5010093
2R61	F2	12 K 10 % 1/8 W	5001043
2R62	B2	68 K 5 % 1/8 W	5010062
2R63	B2	3,3 K 5 % 1/8 W	5010076
2R64	D2	100 K 5 % 1/8 W	5010049
2R65	D2	1,5 K 5 % 1/8 W	5010247
2R66	D2	1,5 K 5 % 1/8 W	5010247
2R67	A3	2,7 M 5 % 1/8 W	5010431
2R68	F2	1 K 10 % 1/2 W	5001029
2R69	F2	33 K 5 % 1/8 W	5010075
2R70	F3	120 K 5 % 1/8 W	5010047
2R71	F2	4,7 K 5 % 1/8 W	5010048
2R72	F2	100 10 % 1/2 W	5001013
2R73	B2	68 K 5 % 1/8 W	5010062
2R74	B1	100 K 10 % 1/2 W	5001055
2R75	B1	33 M 5 % 1/8 W	5010075
2R76	C2	100 K 10 % 1/2 W	5001013
2R77	C2	22 K 5 % 1/8 W	5010079
2R78	A2	10 K 10 % 1/2 W	5001042
2R79	B1	1 K 10 % 1/2 W	5001029
2R80	C2	1,5 K 10 % 1/2 W	5001032
2R81	F3	47 K 5 % 1/8 W	5010411
2R82	F3	47 K 5 % 1/8 W	5010045
2R83	F3	330 10 % 1/2 W	5001021
2R84	F2	100 K 10 % 1/2 W	5001055
2R85	F2	1,2 K 10 % 1/2 W	5001030
2R86	C2	22 K 10 % 1/2 W	5001046
2R87	B1	820 5 % 1/8 W	5010068
2R88	B1	270 5 % 1/8 W	5010000
2R89	C2	680 5 % 1/8 W	5010144
2R90	C2	270 5 % 1/8 W	5010000

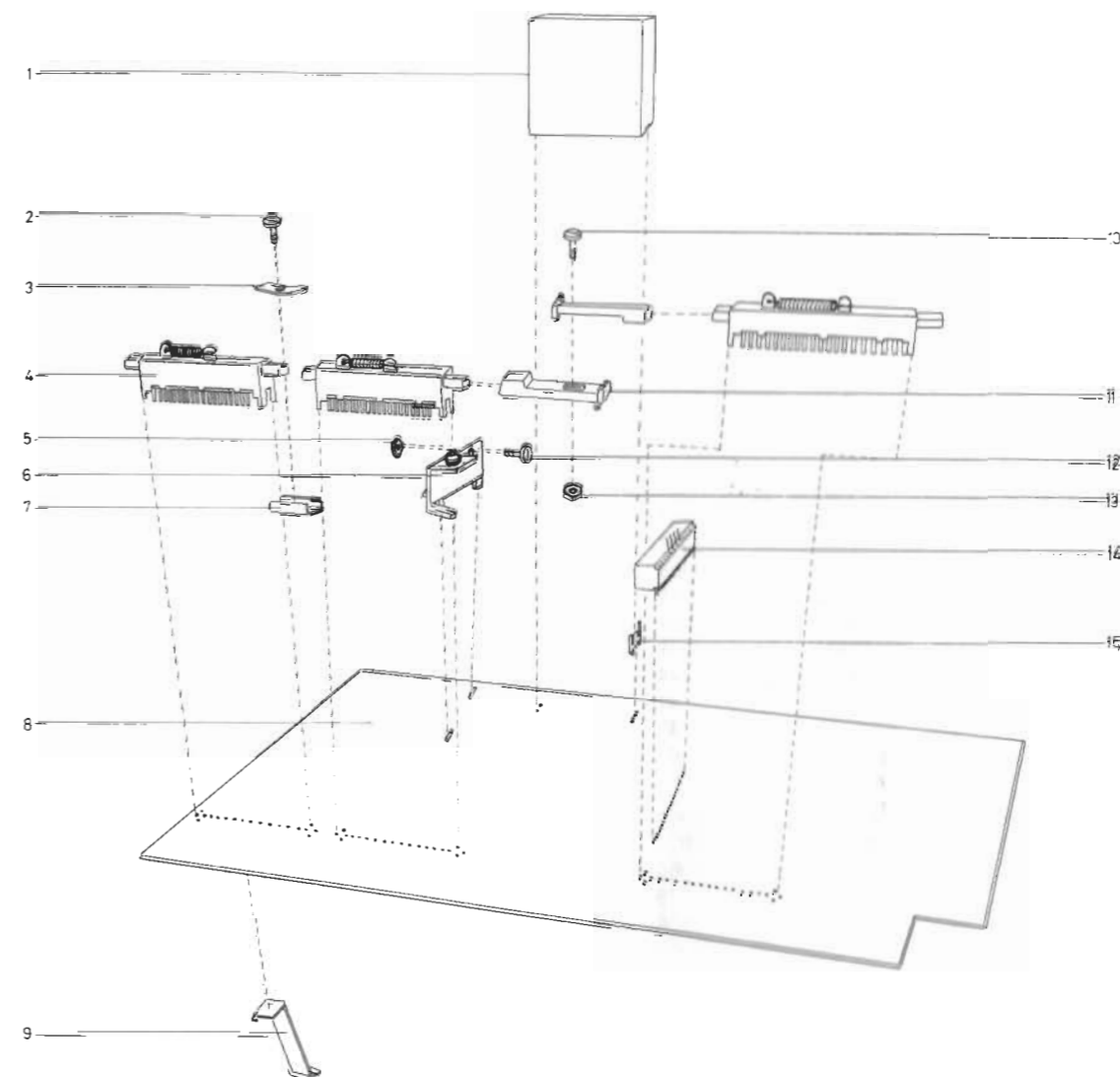

Mekanisk stykliste for PC 8004108

Pos. nr. Index

1	0535432	Hus
2	2038247	AM 3 X 6 DIN 84 skrue
3	2750013	Spændestykke
4	7400076	Omskifter
5	2380009	Møtrik
6	2542349	Vinkel
7	2750014	Spændestykke
8	8004108	PC-enhed
9	2816056	Kontaktfjeder
10	2038247	AM 3 X 6 DIN 84 skrue
11	2640024	Kobling
12	2036213	Skrue
13	2380011	Møtrik
14	7210027	Fatning
15	2395017	Kontaktfjeder

Mechanical parts list for PC 8004108

Housing
AM 3 X 6 DIN 84 screw
Clamp
Switch
Nut
Bracket
Clamp
PC-board
Contact spring
AM 3 X 6 DIN 84 screw
Coupling
Screw
Nut
Socket
Contact spring

Mechanische Stückliste für PC 8004108

Gehäuse
AM 3 X 6 DIN 84 Schraube
Spannstück
Umschalter
Mutter
Winkel
Spannstück
Schaltplatte
Kontaktfeder
AM 3 X 6 DIN 84 Schraube
Küpfung
Schraube
Mutter
Fassung
Kontaktfeder

2R91	A3	68 K 5 % 1/8 W	5010062
2R92	A2	680 5 % 3 W	5100050
2R93	E1	47 K 10 % 1/2 W	5001050
2R94	E1	15 K 10 % 1/2 W	5001044
2R95	E1	1 M 5 % 1/8 W	5010054
2R96	F1	5,6 K 10 % 1/2 W	5001039
2R97	D1	12 K 10 % 1/2 W	5001043
2R98	C1	33 10 % 1/2 W	5001006
2R99	D1	6,8 K 10 % 1/2 W	5001040
2R100	D1	150 10 % 1/2 W	5001016

2VR1	E2	47 K 20 % LIN.	5370061
2VR2	C2	22 K 20 % LIN.	5370068
2VR3	B3	250 20 % LIN.	5370059
2VR4	A1	10 K 20 % LIN.	5370074
2VR5	A2	47 K 20 % LIN.	5370061
2VR6	A3	47 K 20 % LIN.	5370061
2VR7	E3	47 K 20 % LIN.	5370061
2VR8	A2	47 K 20 % LIN.	5370061
2VR9	A1	47 K 20 % LIN.	5370061
2VR10	C2	22 K 20 % LIN.	5370068
2VR11	B1	250 20 % LIN.	5370059
2VR12	A2	10 K 20 % LIN.	5370074
2VR13	E1	10 K 20 % LIN.	5370074
2VR14	F1	10 K 20 % LIN.	5370074

2C1	F1	100 µF, 40 V	4201060
2C2	E2	3,3 nF, 10 % 100 V	4011025
2C3	E2	100 µF, 40 V	4201060
2C4	C1	47 µF, 40 V	4200278
2C5	B2	4,7 µF, 25 V	4200108
2C6	A2	100 µF, 40 V	4201060
2C7	D3	220 pF, 10 % 100 V	4010021
2C8	D2	47 nF, 10 % 250 V	4130087
2C9	D2	4,7 µF, 25 V	4200108
2C10	D2	1 nF 10 % 100 V	4010027
2C11	B3	0,47 µF, 35 V	4201058
2C12	B2	33 nF 10 % 250 V	4130088
2C13	B2	68 nF 10 % 250 V	4130100
2C14	A3	4,7 µF, 63 V	4200283
2C15	B2	270 pF 10 % 100 V	4000013
2C16	B2	47 µF, 16 V	4200092
2C17	C3	0,47 µF, 35 V	4201058
2C18	C3	47 µF, 16 V	4200092
2C19	C2	220 pF, 10 % 100 V	4010021
2C20	C2	4,7 µF, 25 V	4200108
2C21	E3	68 nF 5 % 63 V	4000019
2C22	E2	2,2 µF, 35 V	4201069
2C23	D2	3,3 nF 5 % 63 V	4100033
2C24	E2	0,22 µF, 35 V	4201072
2C25	A1	22 µF, 63 V	4201066
2C26	A2	150 pF, 5 % 63 V	4000023
2C27	D3	100 µF, 16 V	4200099
2C28	E1		
2C29	D1	60 pF	4340003
2C30	F3	100 µF, 16 V	4200099
2C31	D1		
2C32	E1	60 pF	4340003
2C33	A4	150 pF 5 % 63 V	4000023
2C34	F2	3,3 nF 10 % 100 V	4011025
2C35	E2	100 µF, 40 V	4201060
2C36	E2	2,2 µF, 35 V	4201069
2C37	F2	3,3 nF, 5 % 63 V	4100033
2C38	E2	0,22 µF, 35 V	4201072
2C39	B2	4,7 µF, 25 V	4200108
2C40	C1	0,47 µF, 63 V	4200285
2C41	C2	4,7 µF, 25 V	4200108

2C42	A3	4,7 µF, 63 V	4200283
2C43	F3	220 pF 10 % 100 V	4010021
2C44	F2	47 nF 10 % 250 V	4130087
2C45	F3	68 pF, 5 % 63 V	4000019
2C46	F2	4,7 µF, 25 V	4200108
2C47	F2	1 n 10 % 100 V	4010027
2C48	C1	0,47 µF, 35 V	4201058
2C49	B1	33 nF 10 % 250 V	4130088
2C50	B1	270 pF 10 % 100 V	4000013
2C51	B1	47 µF, 16 V	4200092
2C52	B2	68 nF 10 % 250 V	4130100
2C53	C2	220 pF 10 % 100 V	4010021
2C54	C2	47 µF, 16 V	4200092
2C55	A2	22 µF, 63 V	4201066
2C56	D1	100 µF, 40 V	4201060
2C57	E1	1 nF 10 % 100 V	4010027
2C58	E1	100 nF 20 % 250 V	4130103
2C59	F1	100 nF 20 % 250 V	4130103
2C60	F1	220 µF, 16 V	4200097
2C61	C1	47 µF, 63 V	4200278
2C62	D1	3,3 nF 10 % 100 V	4011025
2C62a	D1	100 nF 80 % 30 V	4030008
2C63	C1		
2C64	B1	200 pF	4340005
2C65	B1		
2C66	B1	200 pF	4340005

2L1	B2	8022043	
2L2	A2	8022026	
2L3	A1	8022026	
2L4	B1	8022043	
2L5	C1	8020249	

3TR1	B1	8320069	
3TR2	A1	8320069	
3TR3	B1	8320069	
3TR4	A1	8320137	
3TR5	A1	8320292	

3D1	B1	1N4148 SFD 184	8300058
3D2	A1	1N4148 SFD 184	8300058
3D3	A1	1N4003, 1N4002 EM .502	8300023

3R1	B1	8,2 10 % 1/2 W	5001041
3R2	B1	1M 10 % 1/2 W	5001069
3R3	B1	15 K 10 % 1/2 W	5001029
3R4	A1	15 K 10 % 1/2 W	5001044
3R5	B1	150 K 10 % 1/2 W	5001057
3R6	A1	470 K 10 % 1/2 W	5001065
3R7	A1	15 K 10 % 1/2 W	5001044
3R8	A1	1,8 K 10 % 1/2 W	5001053
3R9	B1	2,2 K 10 % 1/2 W	5001034
3R10	B1	47 K 10 % 1/2 W	5001050
3R11	A1	1,8 K 10 % 1/2 W	5001033
3R12	A1	15 K 10 % 1/2 W	5001044
3R13	B1	39 K 10 % 1/2 W	5001049
3R14	A1	6,8 K 10 % 1/2 W	5001040
3R15	A1	6,8 K 10 % 1/2 W	5001040
3R16	A1	470 10 % 1/2 W	5001056

3C1	B1	2,2 µF 35 V	4201069
3C2	A1	10 µF 63 V	4201065
3C3	B1	47 µF 16 V	4200092
3C4	A1	10 µF 63 V	4201065

3MS1	B1	7600017	
------	----	---------	--

5 PE 8904121			
5TR1	B1	8320295	
5TR2	B1	8320295	
5D1	C2	B40 C800	8300155
5R1	B1	15 K 10 % 1/2 W	5001044
5R2	B1	120 5 % 1/8 W	5001028
5R3	B1	22 K 10 % 1/2 W	5001046
5R4	B1	680 10 % 1/2 W	5001026
5R5	B1	180 5 % 1/8 W	5001036
5R6	B1	56 K 10 % 1/2 W	5001051
5R7	A1	15 K 10 % 1/2 W	5001044
5R8	A1	120 5 % 1/8 W	5001028
5R9	B1	22 K 10 % 1/2 W	5001046
5R10	B1	680 10 % 1/2 W	5001026
5R11	A1	180 5 % 1/8 W	5010362
5R12	A1	56 K 10 % 1/2 W	5001051

5C1	B1	10 µF 16 V	4200101
5C2	C1	47 µF 40 V	4201074
5C3	C1	47 µF 40 V	4201074
5C4	B1	10 µF 16 V	4200101
5C5	A1	47 µF 40 V	4201074
5C6	A1	47 µF 40 V	4201074
5C7	C1	100 nF 20 % 250 V	4130103
5C8	C2	10 nF 20 % 250 V	4130103
5C9	B2	1000 µF 70 V	4200277

5 PC 8004115			
5D1	B1	B40 C 800	8300155
5C1	B1	1000 µF 70 V	4200277
5C2	C2	100 nF 20 % 250 V	4130103
5C3	C1	100 nF 20 % 250 V	4130103

* PC 8004115 indgår i BECCORD 2200 indtil nr. 104815
 PC 8004115 will be in BECCORD 2200 until No. 104815
 Printplatte 8004115 v. nr. BECCORD 2200 bis Nr. 104815 selvf.

6 PC 8004112			
6R1		22 K, LOG	5300080
6R2		22 K, LOG	5300080

7 PC 8004116			
7TR1	C4	8320095	
7TR2	C4	8320095	
7TR3	C3	8320095	
7TR4	A3	8320290	
7TR5	A3	8320095	
7TR6	B3	8320202	
7TR7	B4	8320221	
7TR8	C1	8320095	
7TR9	C1	8320095	
7TR10	C1	8320095	
7TR11	A2	8320290	
7TR12	B1	8320095	
7TR13	B1	8320092	
7TR14	B1	8320221	

7D1	B4	OA 91	8300042
7D2	A4	1N4148, SFD 184	8300058
7D3	B4	ZPD 8,2 V, C8V2	8300173
7D4	A3	OA91	8300042
7D5	B3	1N4148, SFD 184	8300058
7D6	B3	1N4148, SFD 184	8300058
7D7	B1	OA91	8300042
7D8	A1	1N4148, SFD 184	8300058
7D9	B1	ZPD 8,2 V, C8V2	8300173
7D10	A1	OA91	8300042
7D11	B2	1N4148, SFD 184	8300058
7D12	B2	1N4148, SFD 184	8300058

7R1	C4	33 K 5 % 1/8 W	5010075
7R2	B4	2,2 K 10 % 1/2 W	5001046
7R3	B4	2,2 K 10 % 1/2 W	5001034
7R4	B3	15 K 10 % 1/2 W	5001044
7R5	B4	120 K 5 % 1/2 W	5001056
7R6	B4	2,7 K 5 % 1/8 W	5010298
7R7	A3	39 K 5 % 1/8 W	5010060
7R8	A4	6,6 K 10 % 1/2 W	5001040
7R9	B4	680 K 5 % 1/8 W	5010074
7R10	B3	8,2 K 10 % 1/2 W	5001041
7R11	A4	270 K 10 % 1/2 W	5001066
7R12	C4	100 10 % 1/2 W	5001013
7R13	B3	150 K 2 % 1/2 W	5010056
7R14	B3	1 M 2 % 1/4 W	5010026
7R15	C4	150 K 2 % 1/4 W	5010056
7R16	C3	8,2 K 10 % 1/2 W	5001041
7R17	A3	3,3 K 2 % 1/4 W	5010265
7R18	B3	8,2 K 10 % 1/2 W	5001041
7R19	B3	8,2 K 10 % 1/2 W	5001041
7R20	B4	47 K 10 % 1/2 W	5001056
7R21	B4	1 K 5 % 1/8 W	5010040
7R22	C3	1,2 K 5 % 1/8 W	5010153
7R23	C4	6,8 K 5 % 1/8 W	5010052
7R24	C3	3,3 K 10 % 1/2 W	5001036
7R25	C3	3,3 K 10 % 1/2 W	5001048
7R26	B4	27 K 10 % 1/2 W	5001047
7R27	C4	2,7 10 % 1/2 W	5001035
7R28	C3	3,3 K 10 % 1/2 W	5001048
7R29	B3	3,3 K 10 % 1/2 W	5001048
7R30	A4	2,7 K 10 % 1/2 W	5001035
7R31	B3	10 K 10 % 1/2 W	5001042
7R32	B3	33 K 10 % 1/2 W	5001048
7R33	B4	33 10 % 1/2 W	5001066
7R34	B4	47 10 % 1/2 W	5001068
7R35	B4	15 K 10 % 1/2 W	5001044
7R36	A4	270 K 10 % 1/2 W	5001047
7R37	A4	220 K 10 % 1/2 W	5001059
7R37a	C2	1,2 K 5 % 1/8 W	5010153
7R38	C2	1,5 K 10 % 1/2 W	5001032
7R39	C1	33 K 5 % 1/8 W	5010075
7R40	B2	1 M 2 % 1/4 W	5010029
7R41	C1	22 K 10 % 1/2 W	5001046
7R42	B1	2,2 K 10 % 1/2 W	5001034
7R43	B1	15 K 10 % 1/2 W	5001044
7R44	B1	120 K 10 % 1/2 W	5001056
7R45	B1	2,7 K 5 % 1/8 W	5010298
7R46	A2	39 K 5 % 1/8 W	5010056
7R47	A1	6,8 K 10 % 1/2 W	5010052

7R48	B1	680 K 5 % 1/8 W	5010074
7R49	B1	8.2 K 10 % 1/2 W	5001041
7R50	A1	270 K 10 % 1/2 W	5001060
7R51	C1	100 10 % 1/2 W	5001013
5R52	B2	150 K 2 % 1/4 W	5010050
7R53	C1	150 K 2 % 1/4 W	5010050
7R54	C1	8.2 K 10 % 1/2 W	5001041
7R55	A1	3.3 K 2 % 1/4 W	5010265
7R56	B1	8.2 K 10 % 1/2 W	5001041
7R57	B1	8.2 K 10 % 1/2 W	5001041
7R58	B1	47 K 10 % 1/2 W	5001050
7R59	B1	1 K 5 % 1/8 W	5010040
7R60	C1	6.8 K 5 % 1/8 W	5010052
7R61	C2	3.3 K 10 % 1/2 W	5001036
7R62	C2	33 K 10 % 1/2 W	5001048
7R63	C1	27 K 10 % 1/2 W	5001047
7R64	C1	2.7 K 10 % 1/2 W	5001035
7R65	C2	33 K 10 % 1/2 W	5001048
7R66	B2	33 K 10 % 1/2 W	5001048
7R67	A1	2.7 K 10 % 1/2 W	5001035
7R68	B1	10 K 10 % 1/2 W	5001042
7R69	B2	33 K 10 % 1/2 W	5001048
7R70	B1	33 10 % 1/2 W	5001006
7R71	B1	47 10 % 1/2 W	5001008
7R72	B1	15 K 10 % 1/2 W	5001044
7R73	A1	270 K 10 % 1/2 W	5001060
7R74	A1	220 K 10 % 1/2 W	5001059

7VR1	A4	4.7 K 20% LIN.	5370058
7VR2	B4	1 K 20% LIN.	5370050
7VR3	A1	4.7 K 20% LIN.	5370058
7VR4	B1	1 K 20 LIN.	5370050

7C1	C4	10 nF 5 % 63 V	4100026
7C2	C4	4.7 nF 5 % 63 V	4101026
7C3	C4	3.3 nF 5 % 63 V	4100033
7C4	C4	10 μF 16 V	4200101
7C6	B3	10 μF 16 V	4200101
7C7	C3	10 μF 16 V	4200101
7C8	B3	33 nF 1 % 63 V	4100032
7C9	A3	4.7 nF 1 % 63 V	4100031
7C10	A3	10 μF 16 V	4200101
7C11	A3	100 nF 20 % 250	4130103
7C12	B4	47 μF, 6 V	4200228
7C13	B3	10 μF, 16 V	4200101
7C14	B4	100 nF 20 % 250 V	4130103
7C15	B4	10 μF, 16 V	4200101
7C16	B4	100 nF 5 % 250 V	4130101
7C17	A4	100 nF 20 % 250 V	4130103
7C18	B4	330 nF 20 % 100 V	4130106
7C19	C1	10 nF 5 % 63 V	4100026
7C20	C1	4.7 nF 5 % 63 V	4101026
7C21	C1	3.3 nF 5 % 63 V	4100033
7C22	C1	10 μF, 16 V	4200101
7C23	B2	10 μF, 16 V	4200101
7C24	C1	10 μF, 16 V	4200101
7C25	C2	10 μF, 16 V	4200101
7C26	A2	33 nF, 1 % 63 V	4100032
7C27	A2	4.7 nF 1 % 63 V	4100031
7C28	A1	10 μF, 16 V	4200101
7C29	A1	100 nF 20 % 250 V	4130103
7C30	B1	47 μF, 6 V	4200228
7C31	B1	10 μF, 16 V	4200101
7C32	B1	100 nF 20 % 250 V	4130103
7C33	B1	10 μF, 16 V	4200101
7C34	B1	100 nF 5 % 250 V	4130101
7C35	A1	100 nF 20 % 250 V	4130103
7C36	B1	330 nF 20 % 100 V	4130106
7C37	C1	220 μF, 16 V	4200097

7L1	C3	8022047
7L2	C4	8022046
7L3	C1	8022047
7L4	C1	8022046

8 PC 8004113

8R1	A1	1.2 K 5 % 1/8 W	5010153
8R2	A1	1.2 K 5 % 1/8 W	5010153
8R3	A1	1.8 K 5 % 1/8 W	5010066
8R4	A2	1.8 K 5 % 1/8 W	5010066
8R5	A2	1.2 K 5 % 1/8 W	5010153
8R6	A2	1.2 K 5 % 1/8 W	5010153
8R7	A2	5.6 K 5 % 1/8 W	5020041
8R8	A1	5.6 K 5 % 1/8 W	5020041
8R9	A1	5.6 K 5 % 1/8 W	5010041
8R10	A2	5.6 K 5 % 1/8 W	5010041

8C1	A1	47 nF 20 % 250 V	4130078
8C2	A2	47 nF 20 % 250 V	4130078

ADJUSTMENTS

30 V

Connect vacuum-tube voltmeter between chassis and the power-supply heat sink (collector of 2TR24). Adjust potentiometer 2VR13 for 30 V.

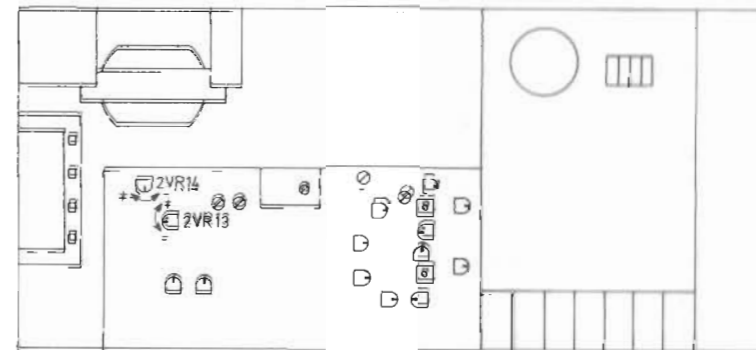

CURRENT LIMITER

2VR14 should be adjusted in the record position with an extra 300-ohm/4-W load across the 30 V supply until the voltage has dropped 1-2 volts.

AZIMUTH



Demagnetize the tape head and erase head. Connect AF vacuum-tube voltmeter to AMP output. Insert azimuth test tape. Play back 6.3 kHz. Adjust screw A for max. and identical output for left and right channels (mean value).

PLAYBACK LEVEL

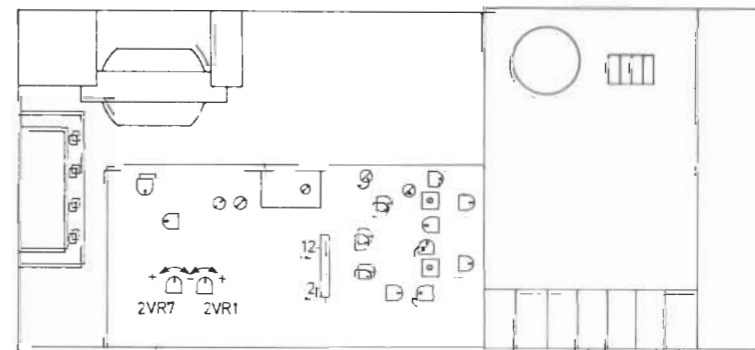

Install filter unit 8004113. Play back test tape with 333 Hz, DIN level. Connect AF vacuum-tube voltmeter to pin 2 of socket for Dolby unit. Adjust 2VR1 so that AF vacuum-tube voltmeter reads 125 mV. Similarly adjust 2VR7 for 125 mV as measured at pin 12.

VU METER

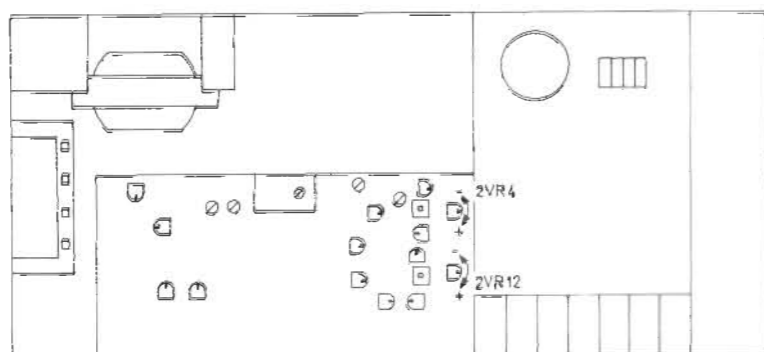

Play back test tape with 333 Hz, DIN level. Adjust 2VR4 so that right-channel VU meter reads +3 dB. Similarly adjust 2VR12 for left channel.

ERASE OSCILLATOR

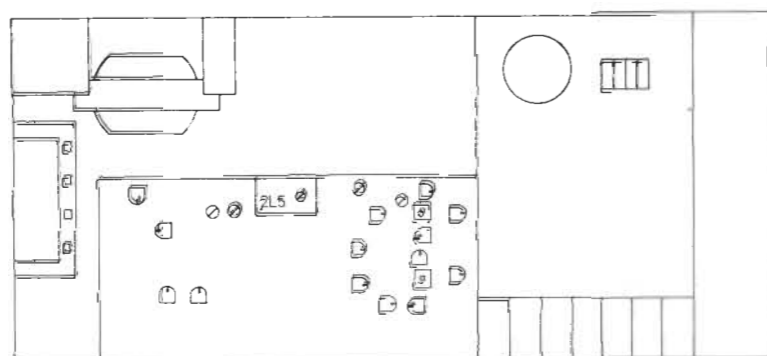

The erase oscillator does not normally require adjustment, but if interference is caused by beat frequencies from the record source, the oscillator frequency may be shifted by means of 2L5.

FILTER FOR BIAS

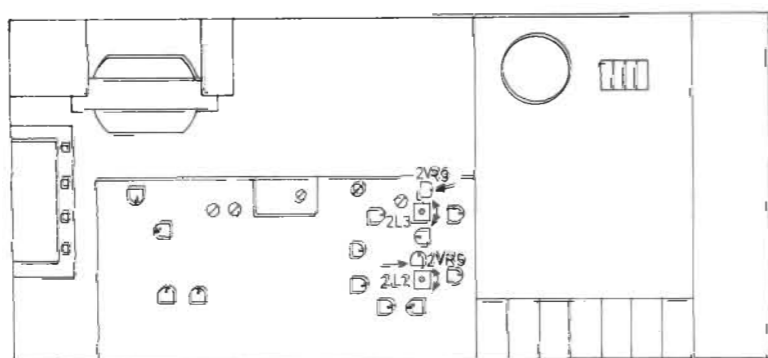

Connect AF vacuum-tube voltmeter to pin of 2VR5 as shown by arrow. Adjust 2L2 for minimum reading. Also adjust 2L3 for minimum reading with the test prod at the slider of 2VR9.

RECORDING LEVEL

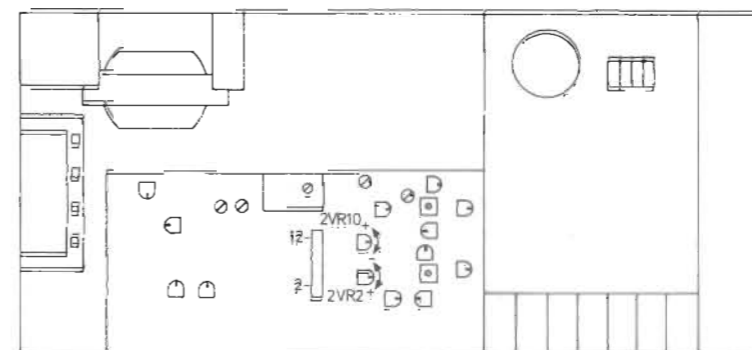

Connect tone generator to AMP input. Set tape recorder to record position. Set tone generator to deliver 333 Hz at approx. 100 mV. Adjust record potentiometer so that 125 mV is present between pins 2 and 12 of filter 8004113. Adjust 2VR2 so that right VU meter reads +3 dB and 2VR10 so that left VU meter reads +3 dB.

BIAS

Depress CrO₂ button. Insert CrO₂ standard tape. Connect tone generator to AMP input. Set to record position with depressed pause button and record potentiometers at 7-8. Set tone generator to 5 kHz and reduce output to 26 dB below VU 0 (adjust to 6 dB below VU 0 and thereafter attenuate by 20 dB). Reset counter.

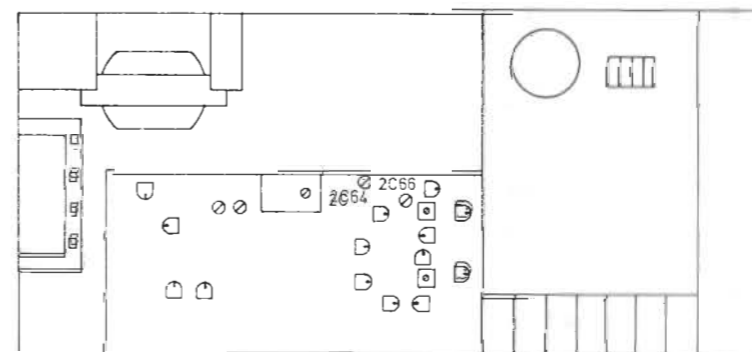

Turn trimmer 2C66 (2C64) to minimum capacitance. Release pause button. Turn trimmer 2C66 (2C64) slowly clockwise until maximum capacitance has been reached; then read counter (e.g. 0015).

Play tape back, watching the output signal level at the AMP output on an AF vacuum-tube voltmeter. When, after having peaked, the signal has dropped 2.5 dB, read counter (e.g. 0010) and AF vacuum-tube voltmeter. Note meter reading. Turn trimmer 2C66 (2C64) to

counter (at 2.5 dB) of trimmer control range (e.g. $\frac{10}{15} = \frac{2}{3}$ of control range) counter (at max.)

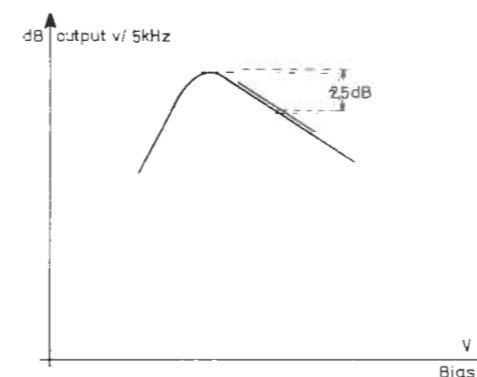

Record 5 kHz at 26 dB below VU 0. Thereafter check if playback level of this signal equals level at 2.5 dB below max. If level is too high, adjust 2C66 (2C64) clockwise (more capacitance); if too low, anti-clockwise. Perform this procedure for both channels. Non-bracketed references refer to right channel; bracketed ones, to left channel.

PLAYBACK FREQUENCY RESPONSE

Playback frequency response **should** be checked with a DIN standard test tape (CrO₂)

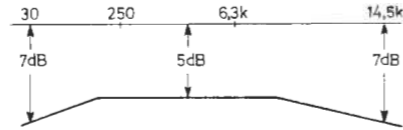

RECORD/PLAYBACK FREQUENCY RESPONSE

Record 30 Hz, 250 Hz, 333 Hz, 6.3 kHz and 14.5 kHz at a level attenuated 26 dB below VU 0. Play back the recorded frequencies; frequency response should be inside the frame sketched above.

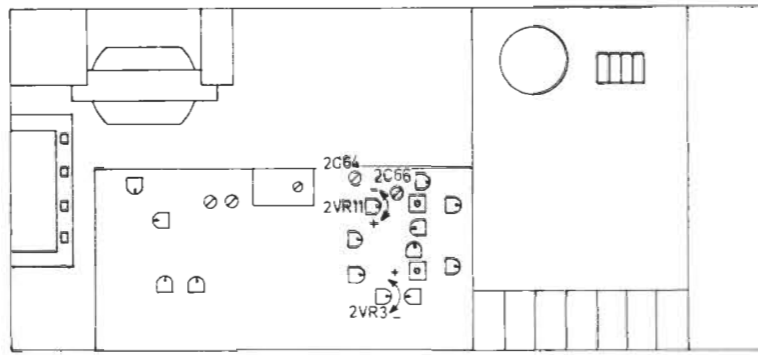

14.5 kHz can be re-adjusted with 2VR3 for right channel and 2VR11 for left channel.

6.3 kHz may likewise be altered by fine adjustment of 2C66 in right and 2C64 in left channel. If level is too high, turn 2C66 (2C64) clockwise (more capacitance).

NOTE: Excessive bias causes treble cut whilst insufficient bias produces distortion in the treble range.

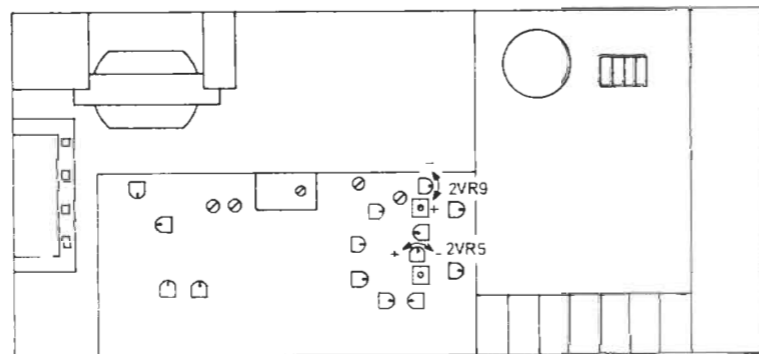
AF RECORD CURRENT, CrO₂

With 2VR5 adjust record current in right channel so that a recorded 333 Hz signal produces the same VU meter reading during both record and playback. Similarly adjust 2VR9 in left channel. Check point is 5 dB below VU 0.

CHECKING DISTORTION (CrO₂)

Distortion via tape is checked at 333 Hz with a distortion meter and a standard CrO₂ tape, at VU 0. Distortion must not exceed 5% (re-adjust bias if necessary).

BIAS, Fe₂O₃

Release CrO₂ button

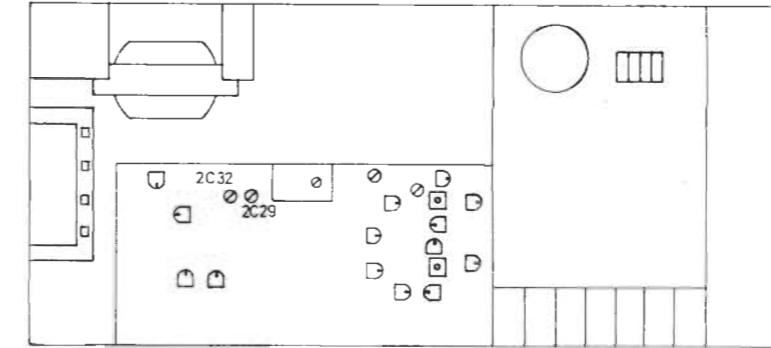

Adjust trimmers 2C29 and 2C32 (install additional capacitor if necessary) for flat frequency response at 6.3 kHz in right and left channels, respectively. Perform check by means of record/playback on Fe₂O₃. 12.5 kHz may be corrected by means of 2VR3 and 2VR11. If correction is made for 12.5 kHz it is necessary to check frequency response for CrO₂ tape

NOTE: Trimmers 2C29 and 2C32 are connected in the circuit in such a manner that higher capacitance gives less bias.

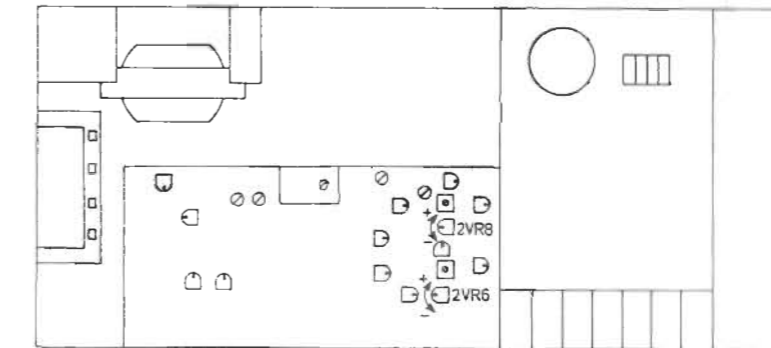
RECORD CURRENT, Fe₂O₃

Proceeding as for CrO₂ tape, adjust 2VR6 and 2VR8 for identical VU meter readings on record and playback (333 Hz). Level: 5 dB below VU 0.

CHECKING DISTORTION (Fe₂O₃)

Distortion via tape is checked at 333 Hz with a distortion meter, a standard Fe₂O₃ tape, at VU 0. Distortion must not exceed 3% (re-adjust bias if necessary).

SPEED ADJUSTMENT

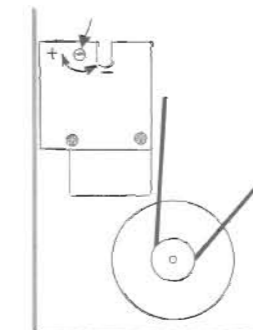

Connect wowmeter to AMP output. Play back wow tape at 3150 Hz. Check wow and speed deviation. Speed may be adjusted if necessary, using the trimmer potentiometer on the motor control circuit board. Indicated by arrow.

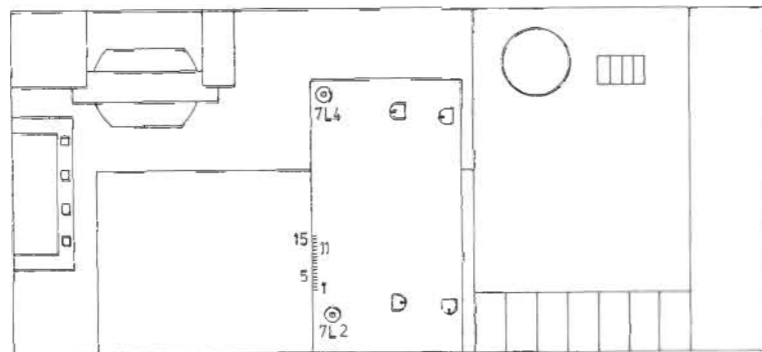
**DOLBY
19 kHz FILTER**

Connect tone generator to pin 5 (15). Output: 19 kHz at 100 mV. Connect AF vacuum-tube voltmeter to pin 1 (11). Adjust 7L2 (7L4) for minimum vacuum-tube voltmeter reading.

SYSTEM AND GAIN

Turn potentiometers 7VR1, 7VR2 and 7VR3 clockwise and 7VR4 anti-clockwise.

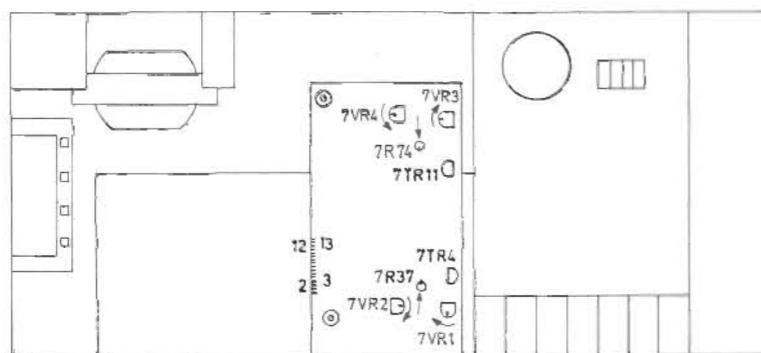

Short-circuit gate of FET transistor 7TR4 (7TR11) to chassis at 7R37 (7R74). Connect tone generator to AMP input. Tone generator output: 5 kHz/25 mV. Connect AF vacuum-tube voltmeter to pin 2 (12). Set tape recorder to record position. Adjust recording level so that 3 mV is present at pin 2 (12). Measure voltage at pin 3 (13) with AF vacuum-tube voltmeter. Depress Dolby button (light). Adjust voltage at pin 3 (13) with 7VR2 (7VR4) so that voltage is 10 dB higher than that previously measured. Remove short-circuit from 7TR4. Adjust voltage at pin 3 (13) with 7VR1 (7VR3) to 2 dB below the value last measured.

PLAYBACK CHECK

Connect tone generator to arm of 2VR1 (2VR7). Dolby button released, no light. Short-circuit gate of 7TR4 (7TR11) to chassis at 7R37 (7R74). Tone generator output: 5 kHz. Set tone generator output voltage so that 7.6 mV is measured with AF vacuum-tube voltmeter connected to pin 2 (12). Depress Dolby button, light. Voltage at pin 2 (12) should drop by 10 dB \pm 0.5 dB. If voltage is not inside the tolerance, perform readjustment (or repair). Remove short-circuit from 7TR4 (7TR11); voltage at pin 2 (12) should rise to 3 mV. When making readjustments or repairs, check the system and Gain record adjustments.

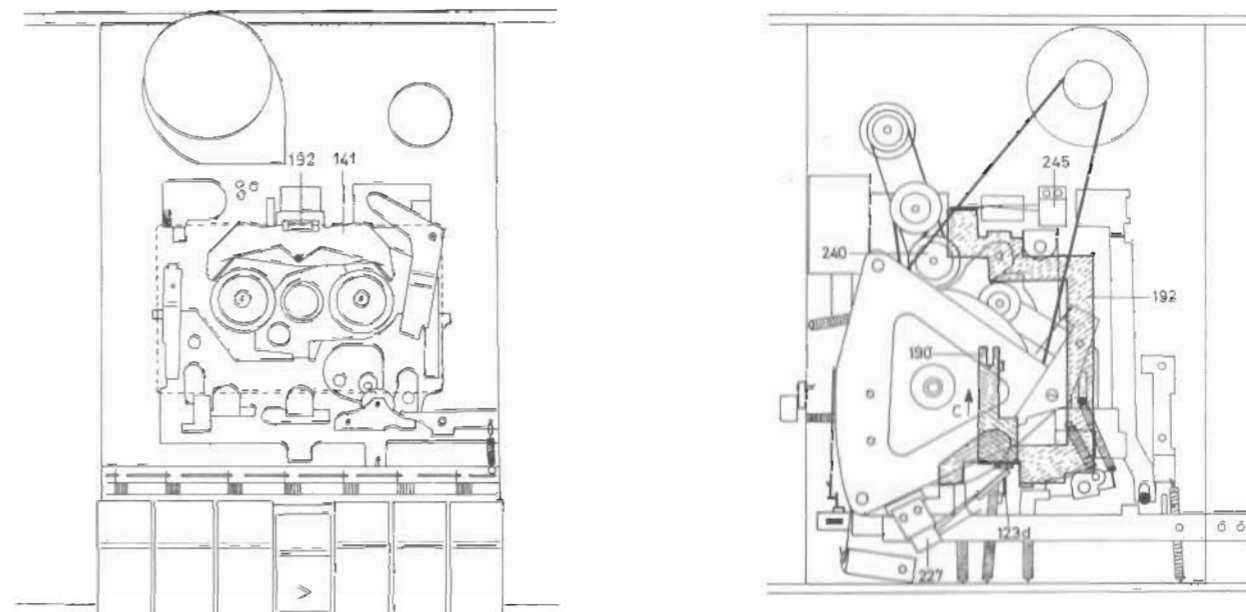
MECHANICAL FUNCTIONS AND ADJUSTMENTS
Normal Forward Tape Motion

When the forward button is depressed, arms 190 and 192 are pushed in the direction of arrow C, with the result that arm 190 via a spring pulls tape heads and thrust roller against the tape in the cassette and arm 192 disengages brakes 141 and actuates switch 245 (42). Arm 123d on the forward button actuates switches 227 (37-38).

When the plate carrying the tape heads and thrust roller is pushed forward, wheel 240 is pulled into engagement with the right turntable, thereby activating the take-up function.

Adjust switches 245 and 227 so that they positively clear the thrust arms in the neutral position and so that they are actuated positively when the forward button is depressed. With the forward button in its operated position, the angle on arm 190 should be bent (adjusted) so that the forward button can be pressed against the stop in the direction of arrow C so that 1 mm travel exists between 190 and 123d. In addition, arm 192 must be capable of being pressed approx. 1 mm in the direction of C.

Take-up moment as measured with moment cassette: 45 p \pm 10 p.

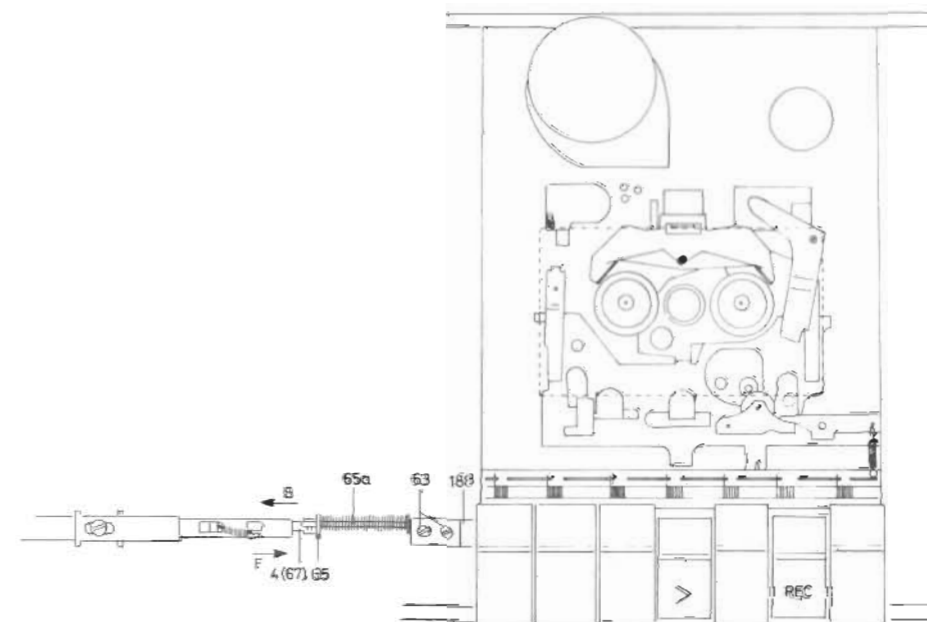
Record

When the REC button is depressed, and the record protection feature is not operative, arm 188 is pushed in the direction of arrow B, thereby actuating the switches on the PC board.

Bar 65a should be adjusted on arm 188 with the REC button released and with the switch arm 4 (67) moved as far as it will go in the direction of arrow F. Loosen screws 63 and push bar 65a in the direction of arrow B so that tipping plate 65 only just touches switches arm 4 (67). Tighten screws 63.

Record Protection

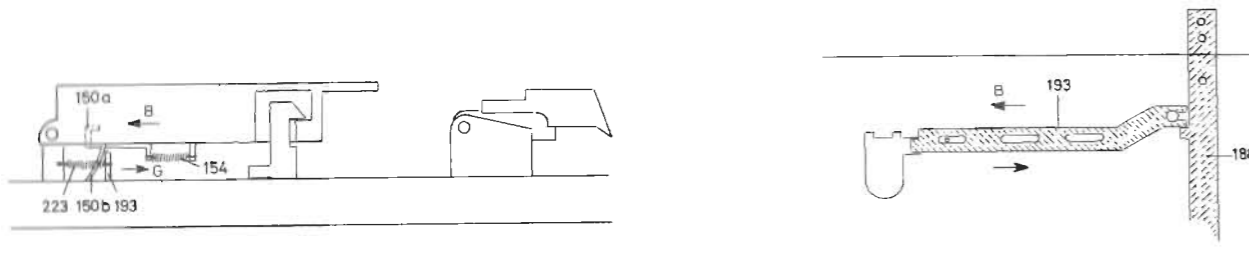

If the record protection hole in the cassette is covered up, arm 150 a will move in the direction of arrow B. Spring 223 will thereafter pull arm 193 in the direction of arrow B so that the record arm 188 can slide clear of arm 193.

If, however, the record protection hole is open, spring 154 will pull arm 150a against the stop in the direction of arrow G. The tag on arm 150 a pushes arm 193 in the direction of arrow G, thereby locking arm 188.

Adjustment is performed by bending tag 150 b.

Tag 150 b should be adjusted so that tag 193 does not move when the cassette lid is opened.

Pause

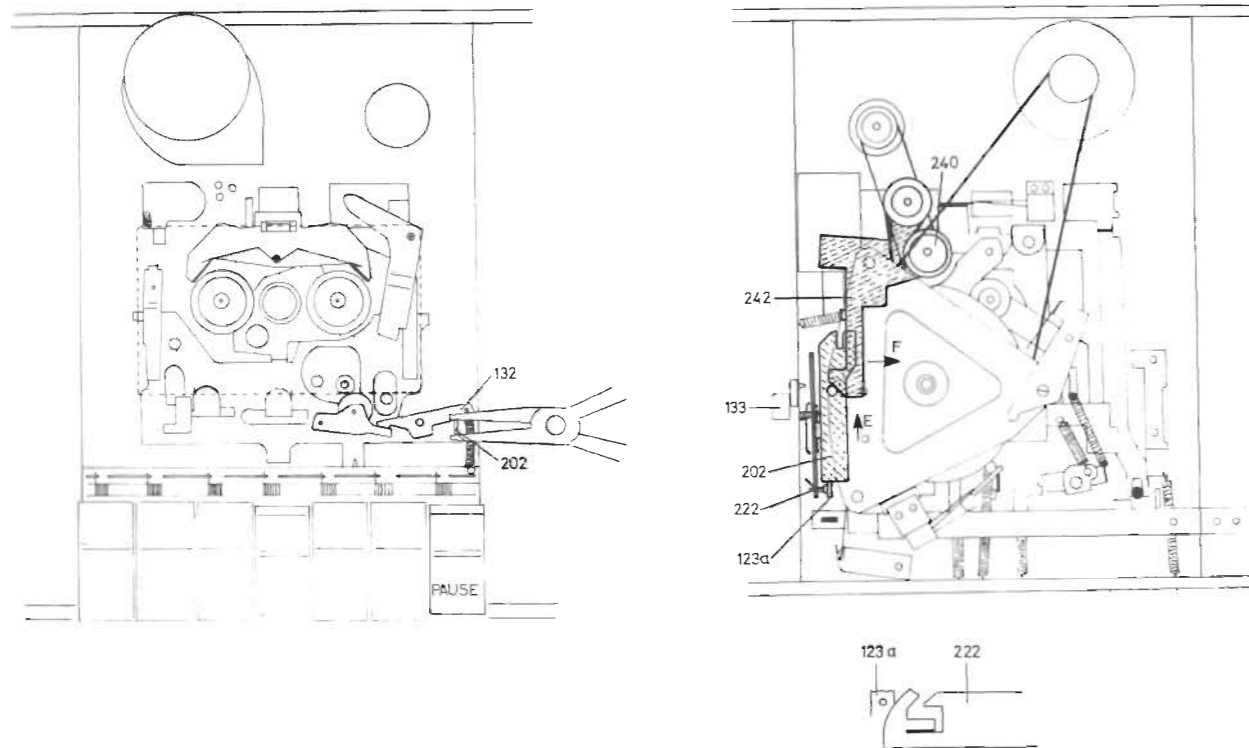

When the pause button is depressed, arm 132 pulls the thrust roller clear of the capstan shaft, and switch 133 is actuated.

Arm 202 is pushed in the direction of arrow E, thereby turning arm 242 with wheel 240 in the direction of arrow F. Wheel 240 disengages from the right-hand reel, and take-up ceases.

Adjust (bend) angle on arm 202 so that the thrust roller pulls clear of the capstan shaft when the pause button is actuated and so that approx. 1 mm clearance exists between arm 132 and the thrust roller arm when the pause button is in its neutral position.

Adjust locking device 222 so that it locks positively at the first pressure and releases positively at the second pressure.

Adjust switch 133 so that switch is open with the button in its neutral position and is short-circuited in the actuated position.

NOTE: The thrust roller arm in some cases has a hole into which arm 132 presses. The pressing tag on arm 132 should be adjusted to clear the hole.

Fast Rewind

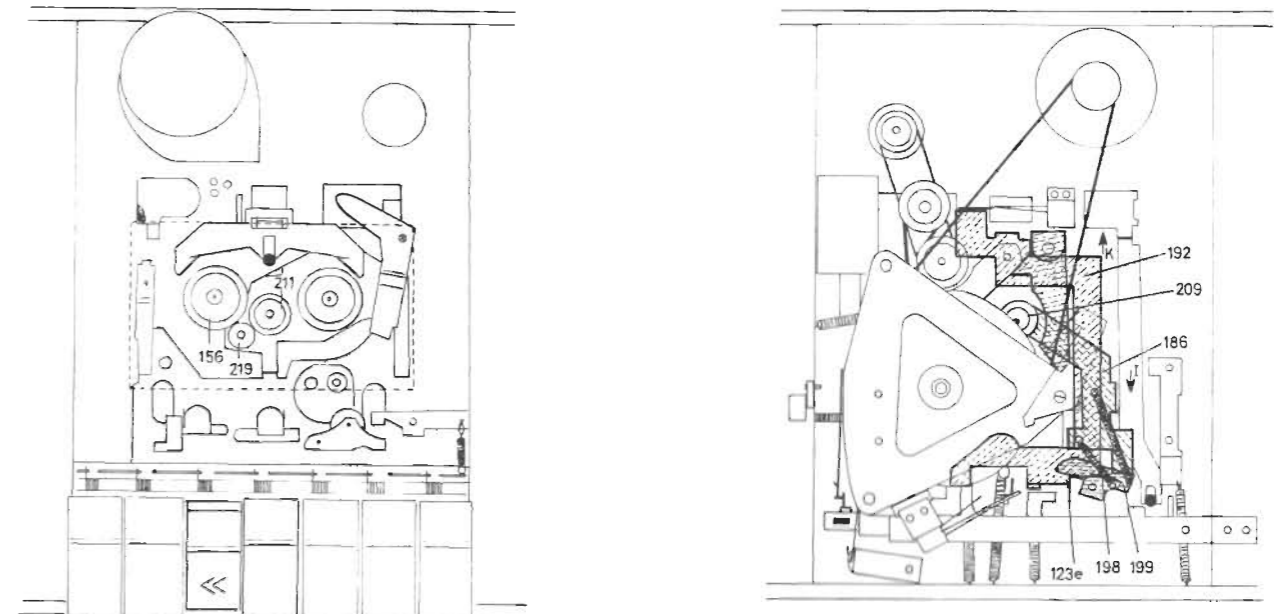

When the fast rewind button is depressed, arm 199 is turned by 123 c. Spring 198 pulls arm 186 with idler wheel 209-211 in the direction of arrow I. Idler wheel 209-211 engages with the flywheel and turntable 156 via idler wheel 219.

The idler wheel arrangement 209-211 incorporates a slip clutch which protects the tape when it is started and when it has been wound up. This slip clutch is common to both the fast forward and rewind setting.

Arm 192 is pushed in the direction of arrow K, thereby disengaging the brakes.

The angle on arm 199 should be bent (adjusted) so that approx. 1 mm clearance exists between 199 and the arm 186 in the rewind setting.

Adjustment of spring 198 and of the parallelism of idler wheel 209-211 with the flywheel should be made so that it is only just the friction clutch that is slipping when the left turntable is held back in the rewind setting.

Fast Forward

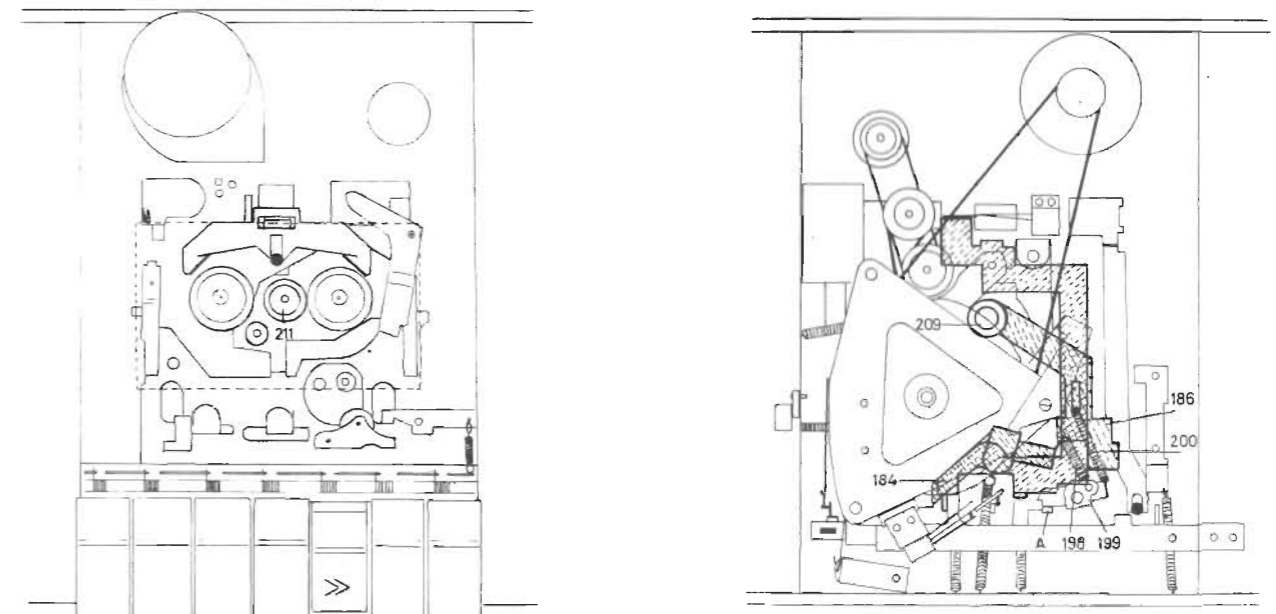

When the fast forward button is depressed, arm 184 is turned. Thereby arm 186 is turned so that idler wheels 209-211 engage with the flywheel and right turntable. Spring 198 holds arm 186 against arm 199 which, in turn, is held against stop A by spring 200.

The leaf spring riveted to arm 186 determines, in conjunction with stop A, the pressure of idler wheels 209-211 against the flywheel and turntable.

The fast forward is adjusted so that it is only just the friction clutch in intermediate wheel arrangements 209-211 that is slipping when the right turntable is held back in the fast forward setting. Adjustment is made by bending of A.

Adjustment of the parallelism of idler wheels 209-211 with the flywheel: See under Fast Rewind.

Stop

The stop button actuates the pushbutton-system release bar, thereby cancelling the settings of the other buttons (except the pause button).

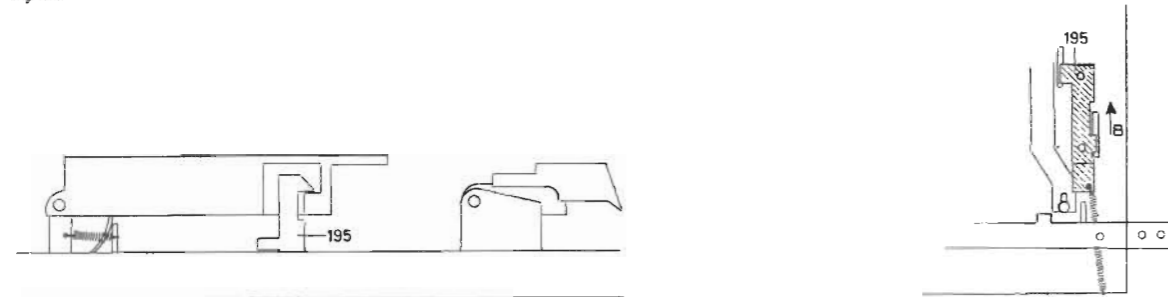
Eject

When the eject button is depressed, arm 195 is pushed in the direction of arrow B, causing arm 195 to disengage from the cassette holder, which is tipped up by a spring at its rear edge.

Magnet Coil (automatic stop)

Bend (adjust) arm 197 so that arm 197 turns against the stop while armature B goes against the stop in the magnet coil.

LUBRICATION

The need for re-lubrication is negligible, but in the case of large overhauls and when replacing major mechanical components these general lines should be followed.

	Lubricate with
Bearing for capstan shaft (top)	3984211 oilit, castrol (small amount)
Bearings for idler wheels 209 and 211	3984216 ROCOL MTS 1000
Tape head slide 129: Surfaces of contact between guide pin and chassis, and arms 190 and 242 Slide faces at guide behind tape head Arm 132: Slide face under arm Balls 137 on both sides of slide Arm 139: Slide face on both sides of pivot point Brake lever 141: Slide faces around 3 guide pins Bearings for turntables 156 and 158 Arm 184: Slide faces against 192 and 186 Arm 186: Slide faces against 192, 183, and 184. Surface of contact with 199 Arm 188: Slide faces against chassis and push-button arm Arm 190: Slide faces against 192, push-button arm and 184 Arm 192: Surfaces of contact around 3 guide pins, between the arm and arms 186, 184 and 190 Arm 195: Slide faces on both sides of chassis Arm 197: Slide face at pivot point Arm 199: Slide face around pivot point. Surface of contact with 186 Arm 202: Slide faces around 2 guide pins and against arm 242 Bearings for idler wheels 219, 239, and 240 Arm 222: Surface of contact with push-button arm Bottom plate 230, bottom bearing for capstan shaft Arm 242: Slide face against 202	3984204 Molykote (paste G, small amount)
Felt washer 214 for idler wheel 211	Keep clean and dry. Clean with benzine if necessary

**PARTS LIST FOR BEOCORD 2200, TYPE 4601
BEOCORD 1700, TYPE 4603**

Pos.	Index No.	Description
1	2568186	Bracket
	3946629	Felt, 55 mm
	3946630	Felt, 132 mm
	3182127	Plate, memory
	3182188	Plate, reset
2	2568188	Front moulding, Beocord 1700
	2568187	Front moulding, Beocord 2200
	3470055	Plastic profile, right
	3470056	Plastic profile, left
3	2775307	Pushbutton off
	2775308	Pushbutton, on
	2775309	Pushbutton, filter
	2775310	Pushbutton, CrO ₂
	2775311	Pushbutton, Dolby
4	3456058	Switch Beocord 1700
	3456050	Switch Beocord 2200
	3370044	Window, red
	3370065	Window, blue
	3370067	Window, green
5	2775221	Slide knob
	3164138	Cover
6	3013025	Guide rail
7	8450023	Indicator, VU-meter
	8230049	Lamp
	3370075	Cover
	3191054	Dial
8	2380011	Nut
9	7530005	Solder tag
10	2812045	Spring
11	2641062	Clamp
	2641061	Clamp
12	6430068	Rubber bushing
13	8230023	Lamp 12 V/0,03 A
14	8230026	Lamp 12 V/1 W
15	3411761	Cabinet teak, left
	3411763	Cabinet rosewood, left
	3411764	Cabinet oak, left
16	8230023	Lamp 12 V/0,03 A
17	7201017	Socket for lamp
18	3454165	Bottom plate
19	3411891	Cabinet, teak
	3411893	Cabinet, rosewood
	3411894	Cabinet, oak
20	3164130	Cover
	3370044	Window, red
21	3164155	Cover
	3164138	Cover for knob
22	3131074	Cover
23	2510096	Clamp
24	8230023	Lamp 12 V/0,03 A
25	7201017	Socket
26	3302212	Screen
27	2819065	Spring
28	2380072	Nut
29	7210025	Socket panel
30	2395028	Spire
31	3411751	Cabinet teak, right
	3411753	Cabinet rosewood, right
	3411754	Cabinet oak, right
32	2038220	Screw AM 3 X 12 DIN 84
	3458102	Top plate, Beocord 1700 complete
	3458099	Top plate, Beocord 2200 complete

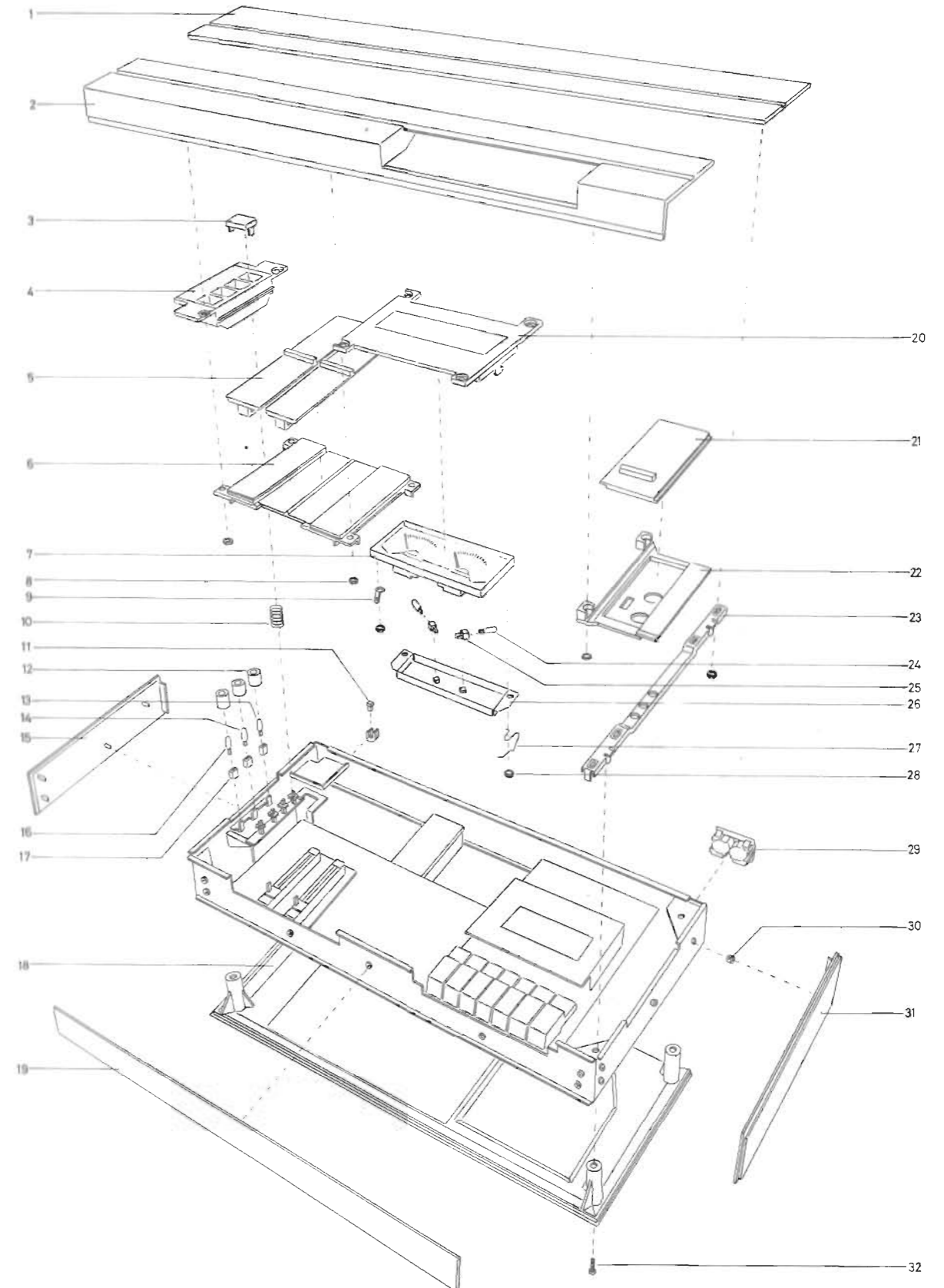

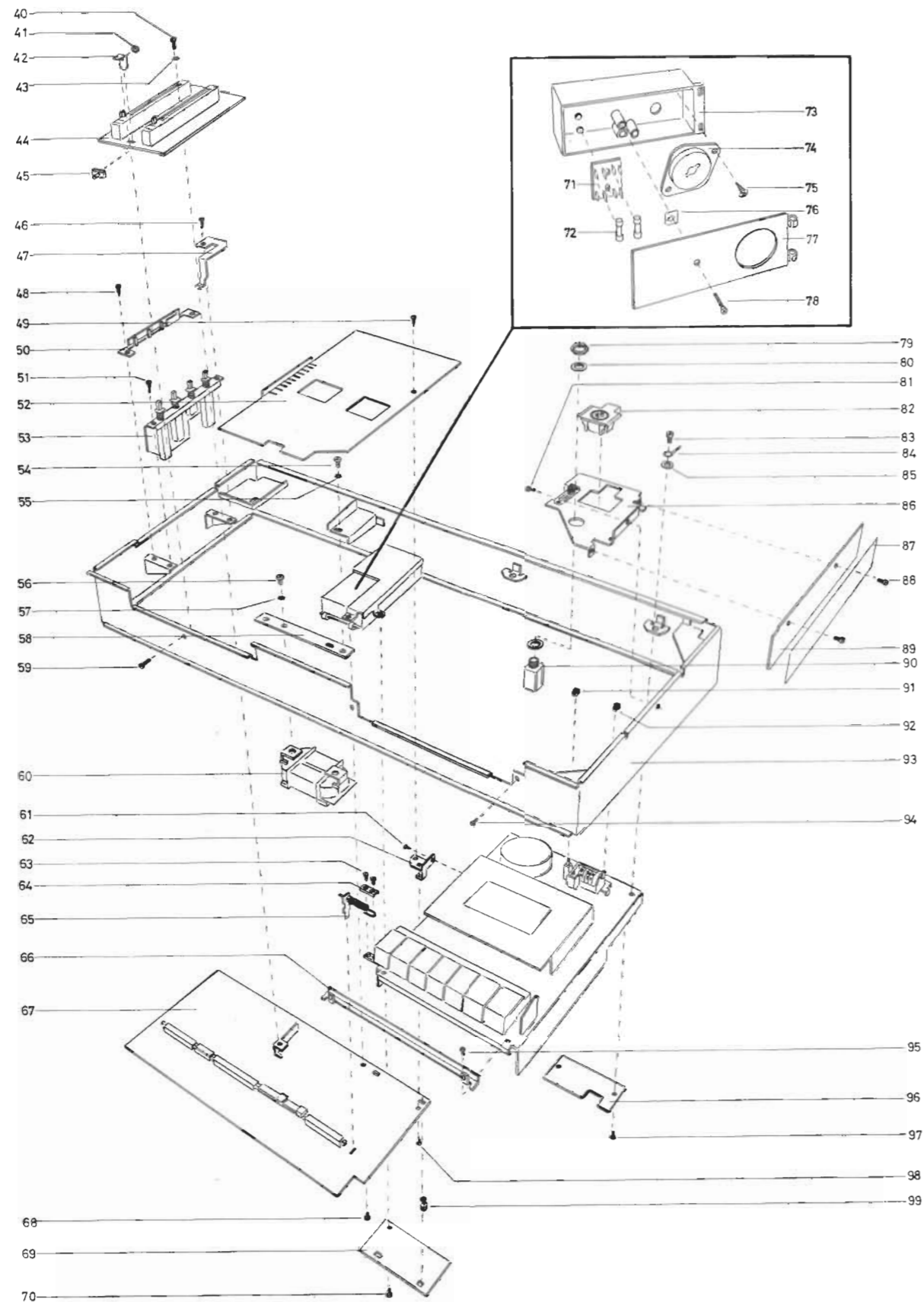

40	2038208	Screw AM 3 X 5 DIN 84
41	2380011	Nut M3
42	2530289	Bracket
43	2625002	Tooth-lock washer
44	8004112	PC-board
45	3152058	Holder
46	2013213	Screw 9,52 X 2,84 mm art 426 1
47	2548077	Bracket
48	2013212	Screw 6,35 X 2,84 mm art 426 1
49	2013212	Screw 6,35 X 2,84 mm art 426 1
50	3152102	Bracket
51	2013212	Screw 6,35 X 2,84 mm art 426 1
52	8004113	PC-board, filter, Beocord 1700
53	8004119	PC-board, Dolby, Beocord 2200
53	8004111	PC-board with pushbutton switch
	7400077	Pushbutton switch
	7450020	Mains switch
54	2042205	Screw AM 4 X 6 mm DIN 84
55	2625003	Tooth-lock washer
56	2042205	Screw AM 4 X 6 mm DIN 84
57	2625003	Tooth-lock washer
58	3152104	Holder
59	2038220	Screw AM 3 X 12 mm DIN 84
60	8013118	Mains transformer
61	2013212	Screw 6,35 X 2,84 mm art 426 1
62	2542373	Bracket
63	2038206	Screw AM 3 X 4 mm DIN 84
64	2542353	Clamp
65	2640028	Arm
66	2542367	Bracket
67	8004108	PC-board
68	2038206	Screw AM 3 X 4 mm DIN 84
69	8004121	PC-board
70	2038206	Screw AM 3 X 4 mm DIN 84
71	3120240	Mounting plate for fuses
	7500033	Contact spring for fuses
72	6600018	Fuse
73	3131078	Housing
74	7401001	Mains-voltage switch
75	2013201	Screw 6,35 X 2,84 mm art 427 1
76	2390020	Locking plate
77	3164140	Cover
78	2039113	Screw AM 3 X 12 mm DIN 84
79	2380099	Nut
80	2622226	Washer
81	2038206	Screw AM 3 X 4 mm DIN 84
82	7210024	Socket, 5 contact, DIN
83	2042205	Screw AM 4 X 6 mm DIN 84
84	7530006	Solder tag
85	2622024	Washer
86	3151130	Bracket
87	3170126	Insulating piece
88	2038206	Screw AM 3 X 4 mm DIN 84
89	8004106	PC-board
90	7212021	Jack socket
91	2775207	Knob, memory
92	2775208	Knob, reset
93	3112123	Chassis
	3182129	Plate, AMP, AUX
94	2038208	Screw AM 3 X 4 mm DIN 84
95	2042205	Screw AM 4 X 6 mm DIN 84
96	8004114	PC-board
97	2038206	Screw AM 3 X 4 mm DIN 84
98	2013212	Screw 6,35 X 2,84 mm art 426 1
99	3152063	Circuit board holder

PARTS LIST FOR BEOCORD 2200 UNTIL NO. 104815

Pos.	Index No.	
22	3131076	Cover
69	8004115	PC-board

- 110 2510109 Holder
- 111 2034211 Screw AM 2 X 6 DIN 84
- 112 2624023 Washer
- 113 8600042 Erase head
- 114 2034925 Screw
- 115 3622215 Washer
- 116 2034926 Screw
- 117 2624023 Washer
- 118 8600041 Tape head
- 119 2036203 Screw AM 2,6 X 4 mm DIN 84
- 120 2624023 Washer
- 121 2816103 Spring
- 122 2390061 Circlip
- 123 2775327 Knobsystem, complete
- 2819086 Spring for pushbutton
- 2775326 Pushbutton, stop
- 2775324 Pushbutton, eject
- 2775325 Pushbutton
- 3912034 Felt for knob
- 124 2853029 Arm
- 125 2390063 Circlip
- 126 2819087 Spring
- 127 2812053 Spring
- 128 2390058 Circlip
- 129 8600043 Tape head bridge
- 130 2810057 Spring
- 131 2390058 Circlip
- 132 2852026 Arm
- 133 7400091 Switch
- 134 2624023 Washer
- 135 2036203 Screw AM 2,6 X 4 DIN 84
- 136 2816104 Spring
- 137 2917016 Ball
- 138 2390058 Circlip
- 139 2854035 Arm
- 140 2819089 Spring
- 141 2853030 Arm
- 142 2036906 Screw AM 2,6 X 6 DIN 84
- 143 2624023 Washer
- 144 2622210 Washer
- 145 2036203 Screw AM 2,6 X 4 DIN 84
- 146 2819088 Spring
- 147 2624023 Washer
- 148 2816104 Spring
- 149 2831024 Shaft
- 150 3131094 Holder
- 3164154 Cover with window
- 2810052 Spring
- 2819090 Spring
- 151 2819090 Spring
- 152 3034028 Lock for cassette
- 153 2810054 Spring
- 154 2810067 Spring
- 155 2390062 Circlip
- 156 2726070 Turntable
- 157 2994013 Lock for turntable
- 158 3140015 Coil for accumulation, complete
- 159 2732024 Belt
- 160 3370082 Counter
- 3356029 Magnet
- 2775329 Resettarm
- 161 7400133 Switch
- 162 2036203 Screw AM 2,6 X 4 DIN 84
- 163 2624023 Washer
- 164 3151120 Holder
- 165 2039904 Screw

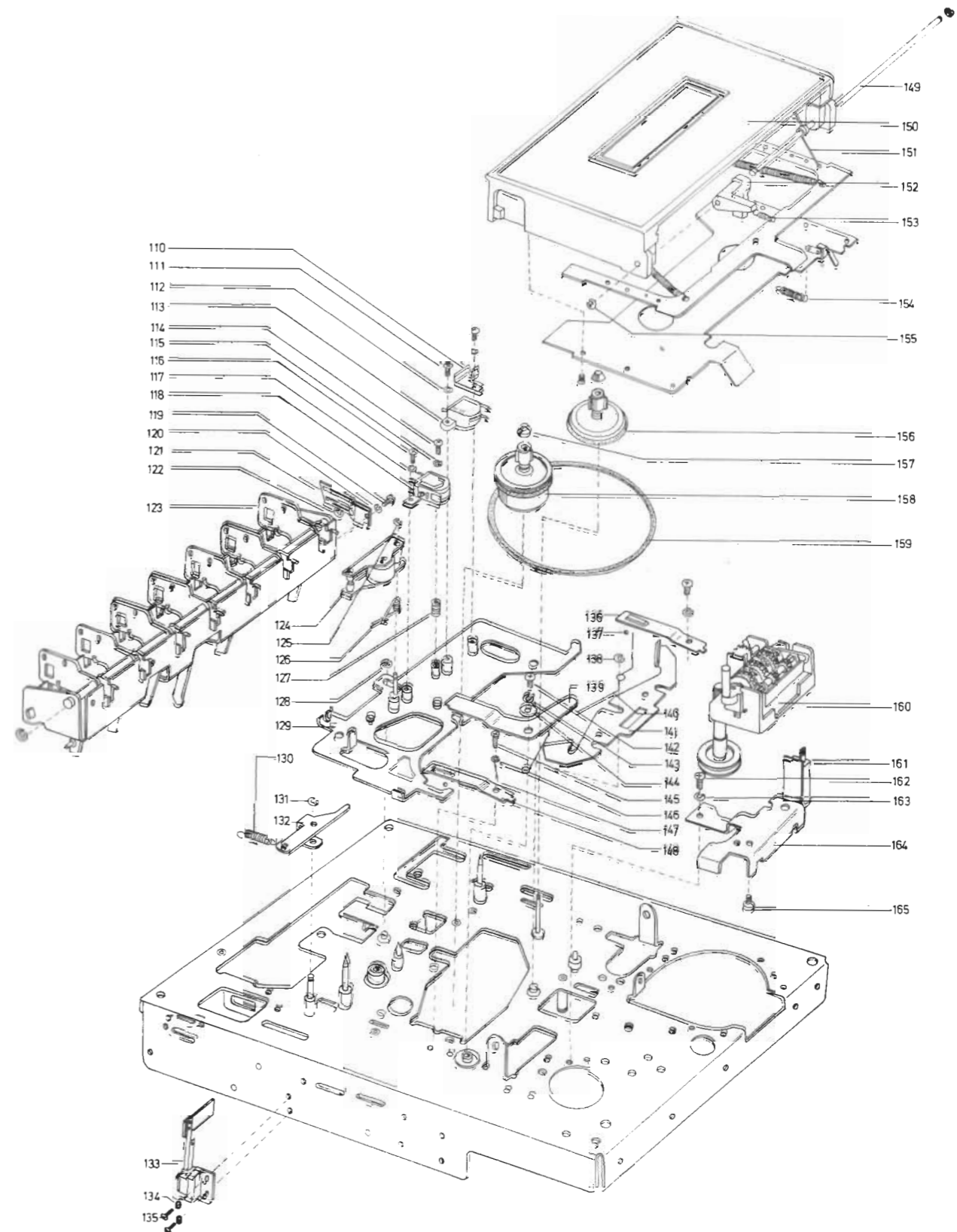

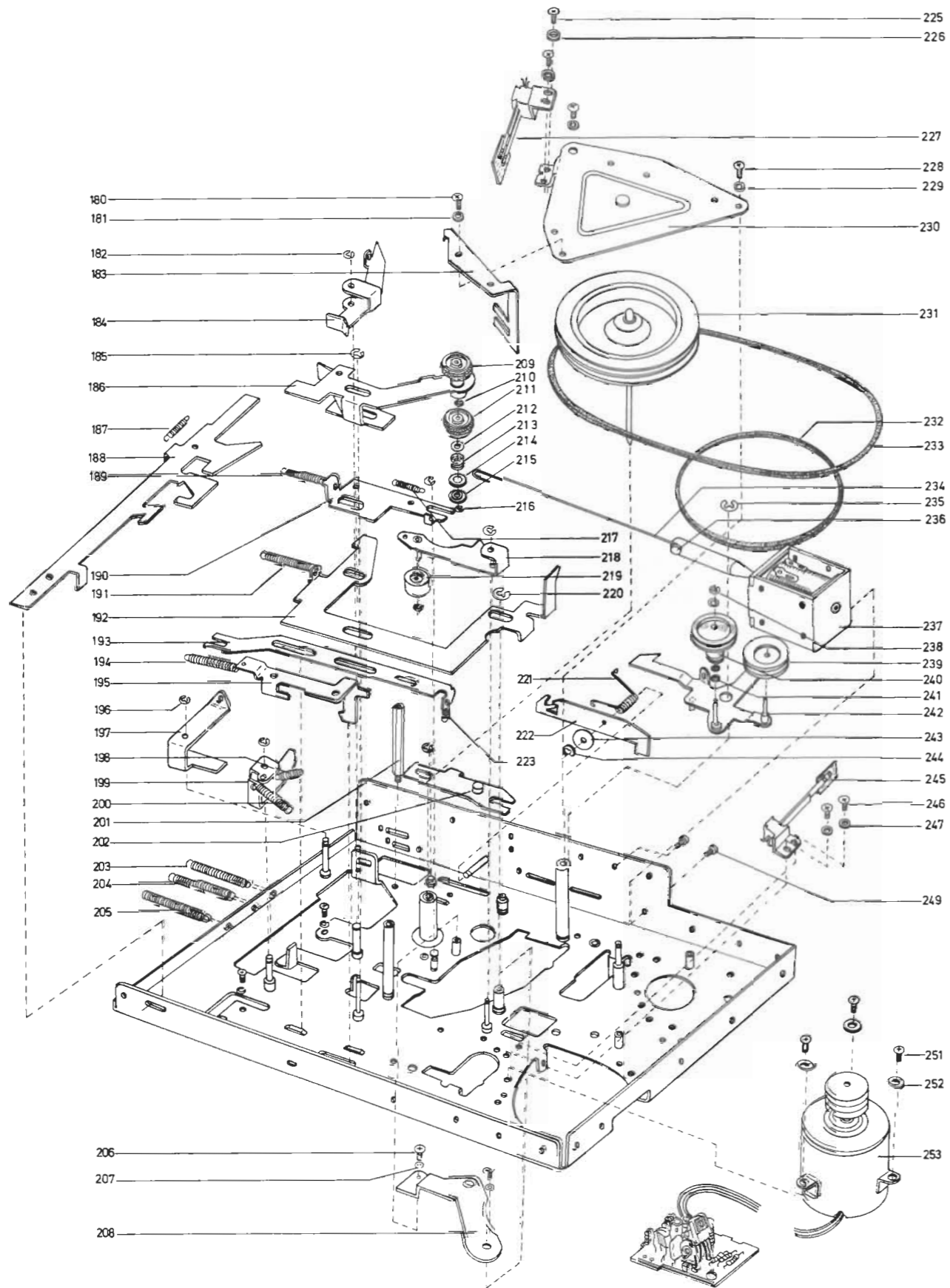

- 180 2036906 Screw AM 2,6 X 6 DIN 84
- 181 2624023 Washer
- 182 2390058 Locking ring
- 183 3151119 Holder for arm
- 184 2641069 Arm
- 185 2390058 Circlip
- 186 2851069 Arm, complete
- 187 2810057 Spring
- 188 2775274 Arm
- 2810070 Spring
- 189 2810059 Spring
- 190 2641068 Arm
- 191 2810060 Spring
- 192 2850072 Arm
- 193 2641067 Arm
- 194 2810060 Spring
- 195 3034027 Arm
- 196 2390058 Circlip
- 197 2641072 Arm
- 198 2810061 Spring
- 199 2641070 Arm
- 200 2810062 Spring
- 201 2932067 Spacer
- 202 2641071 Arm
- 203 2810060 Spring
- 204 2810059 Spring
- 205 2810060 Spring
- 206 2036203 Screw AM 2,6 X 4 DIN 84
- 207 2624023 Washer
- 208 3150026 Arm
- 209 2850064 Idler Wheel
- 210 2622214 Locking ring
- 211 2794042 Idler Wheel
- 212 2622210 Washer
- 213 2812052 Spring
- 214 2620050 Felt washer
- 215 2620049 Washer
- 216 2390063 Locking ring
- 217 2810058 Spring
- 218 2851068 Arm
- 219 2794041 Idler Wheel
- 2390062 Locking ring
- 220 2390060 Circlip
- 221 2819092 Spring
- 222 2852027 Arm
- 223 2810055 Spring
- 225 2036203 Screw AM 2,6 X 4 DIN 84
- 226 2624023 Washer
- 227 7400092 Switch
- 228 2036203 Screw AM 2,6 X 4 DIN 84
- 229 2624023 Washer
- 230 3122081 Mounting plate
- 2804032 Nylon washer
- 231 2794044 Flywheel
- 232 2732029 Belt
- 233 2732022 Belt
- 234 2850065 Arm
- 235 2390059 Circlip
- 236 2992050 Pin
- 237 7600021 Magnet coil
- 238 2390063 Circlip
- 239 2804030 Idler Wheel
- 240 2794043 Idler Wheel
- 241 2622215 Washer
- 242 2851075 Arm
- 243 2622209 Washer
- 244 2390058 Circlip
- 245 7400090 Switch
- 246 2036203 Screw AM 2,6 X 4 DIN 84
- 247 2624023 Washer
- 249 2039904 Screw

251	2036906	Screw AM 2,6 X 6 DIN 84
252	2624023	Washer
253	8400057	Motor
	2724031	Pulley
	2070400	Threaded pin

NOT SHOWN PARTS

6271047	Mains lead
3534080	Instruction diagram
3458102	Top Plate Beocord 1700 complete
3458099	Top Plate Beocord 2200 complete
3391410	Top/bottom inserts
3391411	Outer carton
3397176	Foam packing
3397185	Insert

SERVICE TIPS

Removal of Push-button System

Loosen screws 180 and 228a and remove spring 130 for pause lever. The push-button system may now be taken out after removal of screw 228b, spacer 201, and screws 206a and 206b.

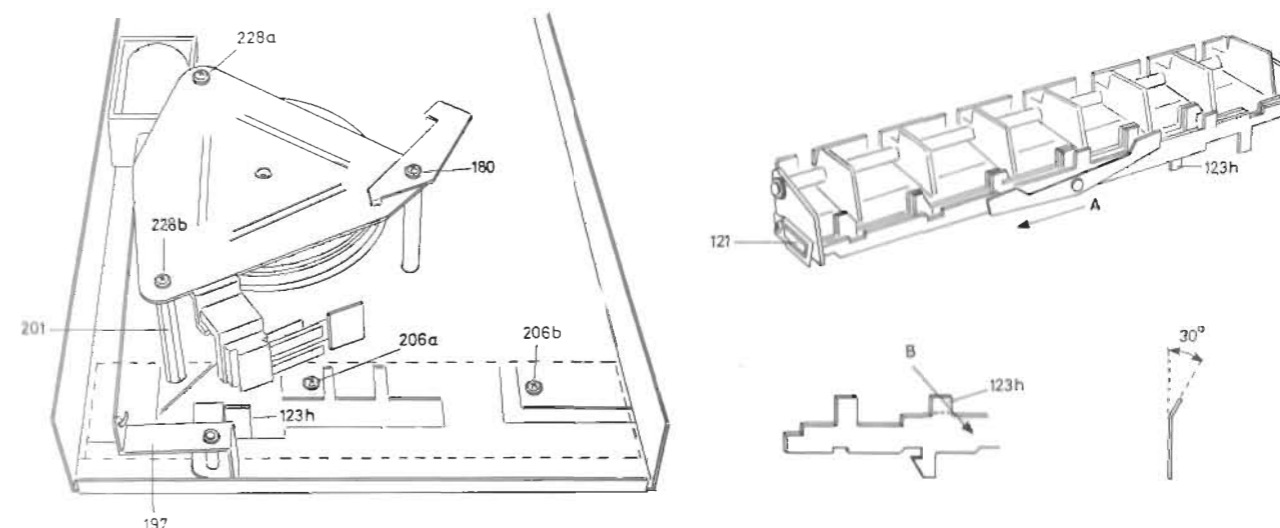

Push-button System Blocking

In the first-produced units it is possible, under unfavourable circumstances, for arm 197 for automatic stop to get wedged against the slide 123h, thereby blocking the slide on the push-button system. The fast forward and rewind buttons will not stay depressed when the system blocks as described.

To repair the defect, proceed as follows:

Remove the push-button system.

Remove spring 121. Remove the slides by moving them in the direction of arrow A. Bend the tag on slide 123h, as shown in the sketch, approx. 30 deg. in the direction of arrow B.

Pressure Wheel

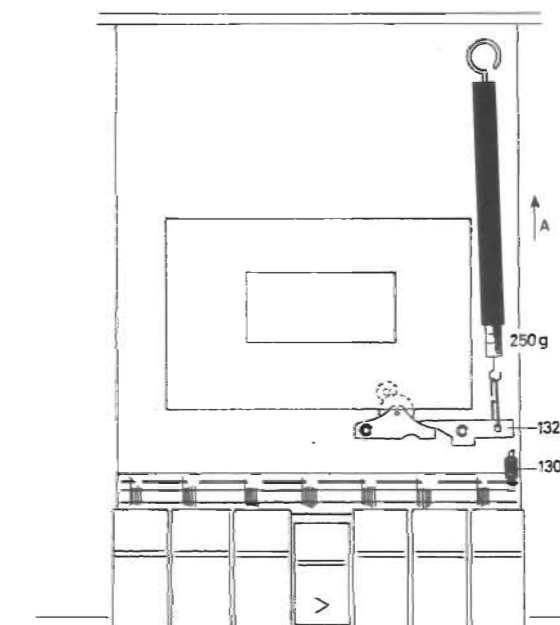

The pressure of the pressure wheel against the capstan shaft may be checked in the following manner:

Take off spring 130. Fasten spring balance (500 or 1000 gr.) to arm 132, see sketch. Set tape recorder to normal forward tape travel with the cassette lid open. Pull spring balance in the direction of arrow A until clearance exists between the pressure wheel and the capstan. Ease the pressure at the spring balance to the point immediately before the pressure wheel again touches the capstan shaft. The spring balance should now read approx. 250 gr.

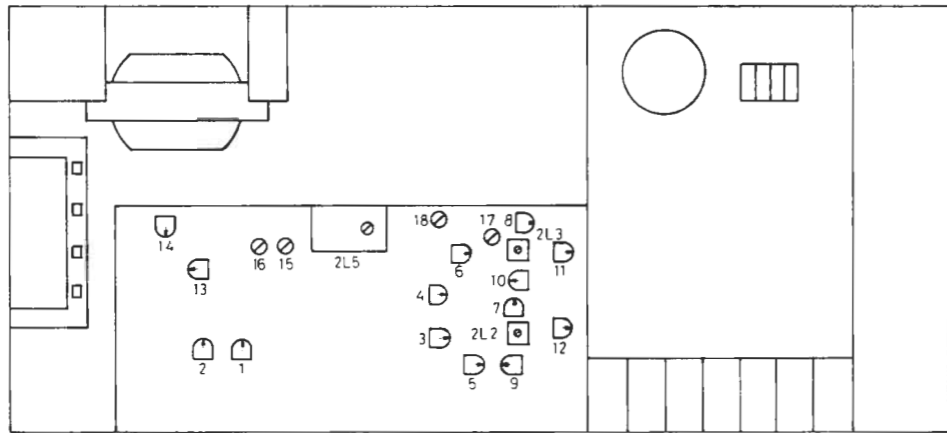

2L2 100 kHz filter	R	2L2 100 kHz filter	R	2L2 100 kHz filter	R
2L3 100 kHz filter	L	2L3 100 kHz filter	L	2L3 100 kHz filter	L
2L5 100 kHz osc.		2L5 100 kHz osc.		2L5 100 kHz osc.	
1 Playback level	R	1 Wiedergabe niveau	R	1 Gengive niveau	R
2 Playback level	L	2 Wiedergabe niveau	L	2 Gengive niveau	L
3 Record level	R	3 Aufnahme niveau	R	3 Optage niveau	R
4 Record level	L	4 Aufnahme niveau	L	4 Optage niveau	L
5 Equal just.	R	5 Equal just.	R	5 Equal just.	R
6 Equal just.	L	6 Equal just.	L	6 Equal just.	L
7 Record current CrO ₂	R	7 Aufnahme strom CrO ₂	R	7 Opt. strom CrO ₂	R
8 Record current CrO ₂	L	8 Aufnahme strom CrO ₂	L	8 Opt. strom CrO ₂	L
9 Record current Fe ₂ O ₃	R	9 Aufnahme strom Fe ₂ O ₃	R	9 Opt. strom Fe ₂ O ₃	R
10 Record current Fe ₂ O ₃	L	10 Aufnahme strom Fe ₂ O ₃	L	10 Opt. strom Fe ₂ O ₃	L
11 VU-meter just.	R	11 VU-meter just.	R	11 VU-meter just.	R
12 VU-meter just.	L	12 VU-meter just.	L	12 VU-meter just.	L
13 30V just.		13 30V just.		13 30V just.	
14 Current limiter		14 Strom begrenzung		14 Strom begrænser	
15 Bias Fe ₂ O ₃	R	15 Bias Fe ₂ O ₃	R	15 Bias Fe ₂ O ₃	R
16 Bias Fe ₂ O ₃	L	16 Bias Fe ₂ O ₃	L	16 Bias Fe ₂ O ₃	L
17 Bias CrO ₂	R	17 Bias CrO ₂	R	17 Bias CrO ₂	P
18 Bias CrO ₂	L	18 Bias CrO ₂	L	18 Bias CrO ₂	L

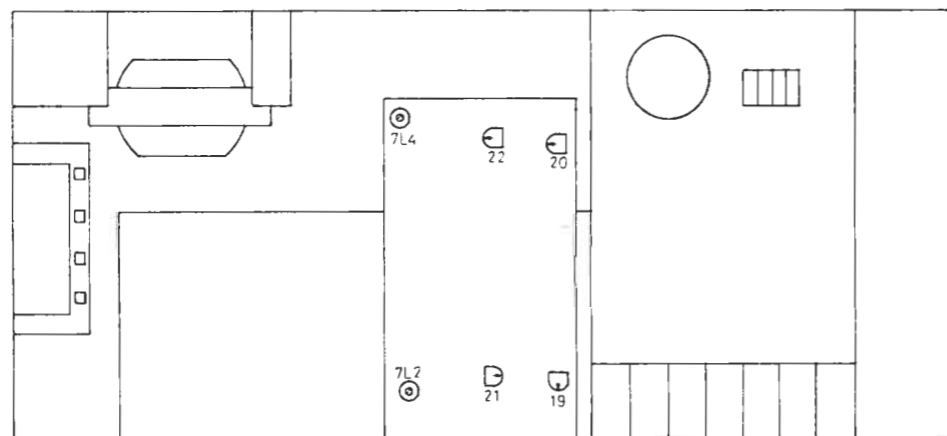

7L2 19 kHz filter	R	7L2 19 kHz filter	R	7L2 19 kHz filter	R
7L4 19 kHz filter	L	7L4 19 kHz filter	L	7L4 19 kHz filter	L
19 Low control	R	19 Systemkontrolle	R	19 System kontrol	R
20 Low control	L	20 Systemkontrolle	L	20 System kontrol	L
21 Gain control	R	21 Verstärkungskontrolle	P	21 Forstærkning	R
22 Gain control	L	22 Verstärkungskontrolle	L	22 Forstærkning	L

Conditions of measurement for circuit diagram

All voltages are measured in position play-back and Pause-button depressed with a vacuum tube voltmeter (internal resistance 1 M ohm). () in position record without signal.

Diagram explanation

The plug pins are filled in, whereas the wall sockets are indicated as holes.

Resistors with no markings:	0.5W carbon
Resistors marked KF:	0.125W or 0.33W carbon film
Resistors marked TE:	Wire-wound
Capacitors with no markings:	Ceramic
Capacitors marked HK:	Ceramic (high K)
Capacitors marked KBL:	Ceramic barrier-layer
Capacitors marked PS:	Polystyren 63V
Capacitors marked PS ₁ :	Polystyren 125V
Capacitors marked MK ₁ :	Metallized polyester 160V
Capacitors marked MK ₂ :	Metallized polyester 250V

Messbedingungen für Instruktionsschaltbild

Alle Spannungen sind bei Wiedergabe und Pause-Knopf gedrückt mit einem Röhrevoltmeter (Innenwiderstand 1 M ohm) gemessen. () bei Aufnahme ohne Signal.

Erklärung zu den Schaltbildern

Bei den Steckern sind die Stifte ausgefüllt markiert, während die Buchsen durch offene Kreise gekennzeichnet sind.

Widerstände ohne Markierung:	0.5W Masswiderstand
Widerstände markiert KF:	0.125W oder 0.33W Kohleschicht
Widerstände markiert TE:	Drahtwiderstand
Kondensatoren ohne Markierung:	Keramische
Kondensatoren markiert HK:	Keramische Kondensatoren HDK
Kondensatoren markiert KBL:	Keramische Kondensatoren NRK
Kondensatoren markiert PS:	Polystyren 63V
Kondensatoren markiert PS ₁ :	Polystyren 125V
Kondensatoren markiert MK ₁ :	Metallisierter Polyester 160V
Kondensatoren markiert MK ₂ :	Metallisierter Polyester 250V

Målebetingelser for instruktionsdiagram

Alle spændinger er målt i stilling gengive med Pause-knoppen nedtrykket med rørvoltmeter (indre modstand 1 M ohm). () i stilling optage uden signal.

Diagramforklaring

Stikpropperne er angivet med benene udfyldte, medens stikkontakterne er angivet som huller.

Modstande uden angivelse:	0.5W kulmasse
Modstande mærket KF:	0.125W eller 0.33W kulfilm
Modstande mærket TE:	Enkeltråd
Kondensatorer uden angivelse:	Keramiske
Kondensatorer mærket HK:	Keramiske (høj K)
Kondensatorer mærket KBL:	Keramiske barrier-layer
Kondensatorer mærket PS:	Polystyren 63V
Kondensatorer mærket PS ₁ :	Polystyren 125V
Kondensatorer mærket MK ₁ :	Metalliseret polyester 160V
Kondensatorer mærket MK ₂ :	Metalliseret polyester 250V

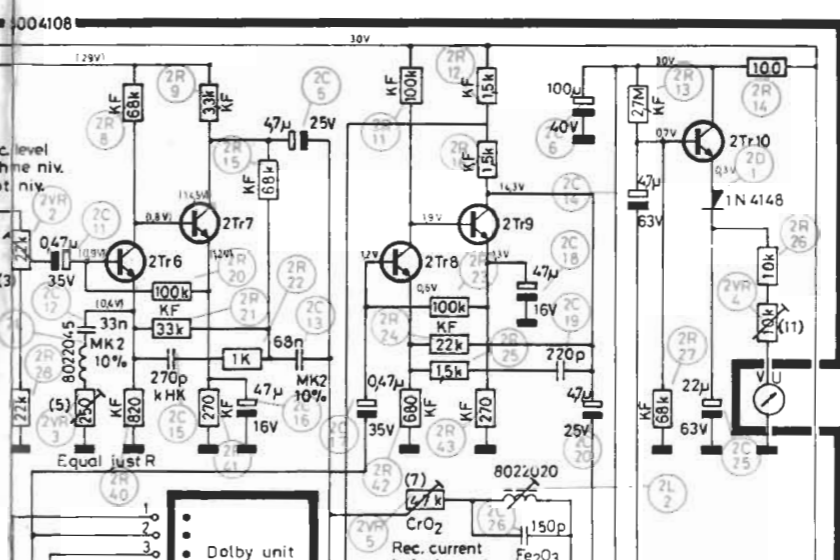
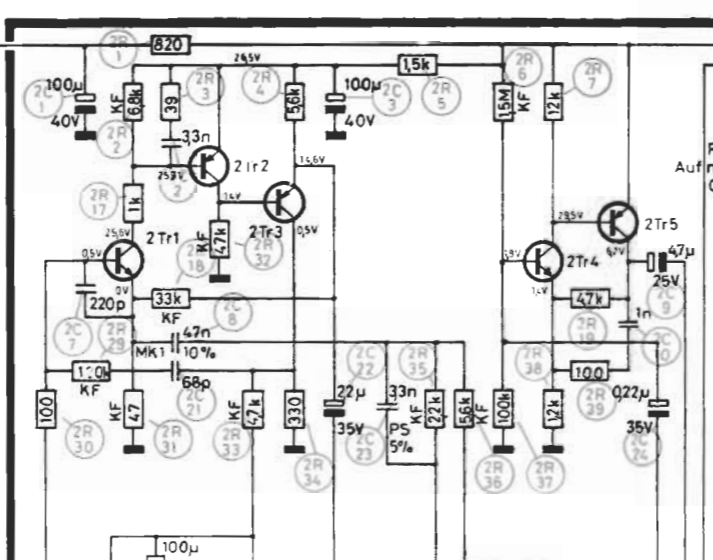
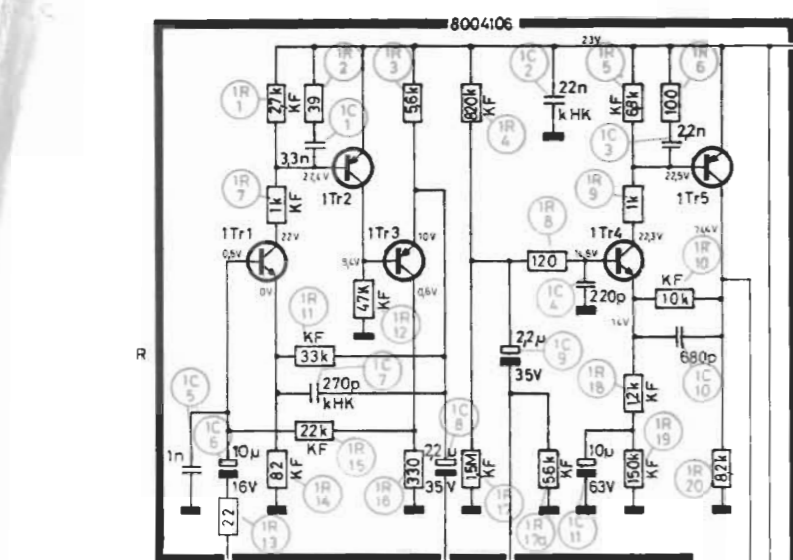

1TR1 8320139	2TR5 8320202	2TR19 8320097	7TR1 8320095
1TR2 8320069	2TR6 8320097	2TR20 8320285	7TR2 8320095
1TR3 8320069	2TR7 8320097	2TR21 8320137	7TR3 8320095
1TR4 8320095	2TR8 8320097	2TR22 8320137	7TR4 8320290
1TR5 8320069	2TR9 8320097	2TR23 8320097	7TR5 8320095
1TR6 8320139	2TR10 8320285	2TR24 8320241	7TR6 8320202
1TR7 8320069	2TR11 8320139	3TR1 8320069	7TR7 8320221
1TR8 8320069	2TR12 8320069	3TR2 8320069	7TR8 8320095
1TR9 8320095	2TR13 8320069	3TR3 8320069	7TR9 8320095
1TR10 8320069	2TR14 8320097	3TR4 8320137	7TR10 8320095
2TR1 8320139	2TR15 8320202	3TR5 8320292	7TR11 8320290
2TR2 8320069	2TR16 8320097		7TR12 8320095
2TR3 8320069	2TR17 8320097		7TR13 8320202
2TR4 8320097	2TR18 8320097		7TR14 8320221

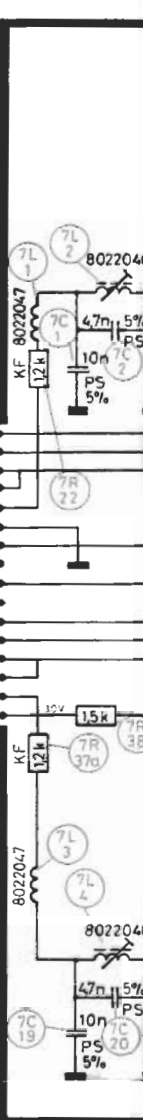
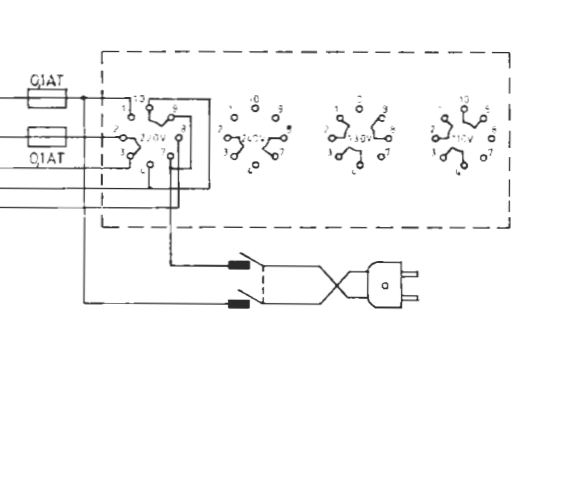
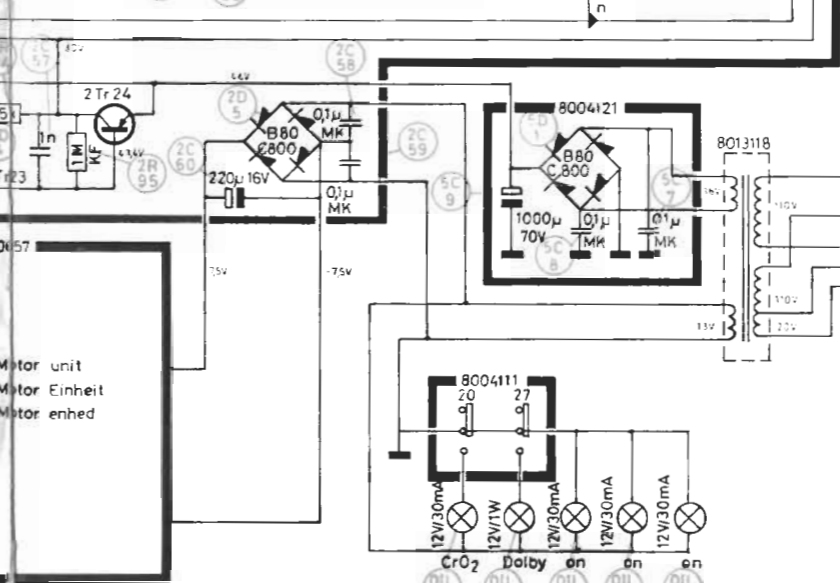
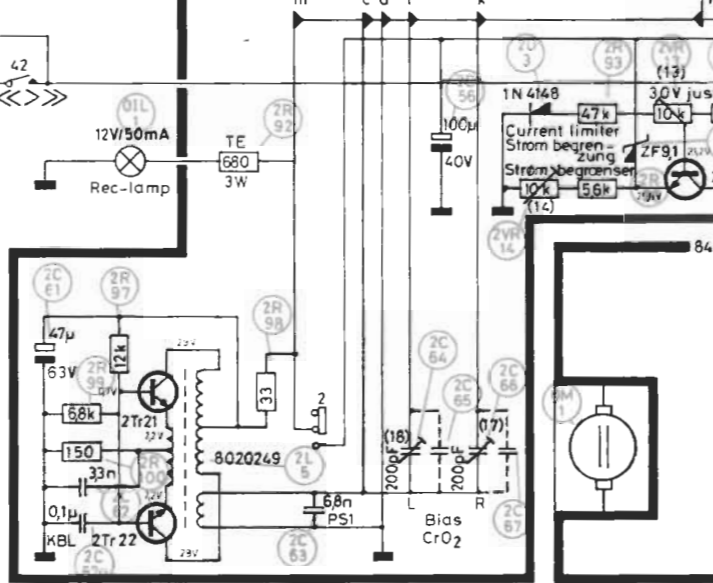
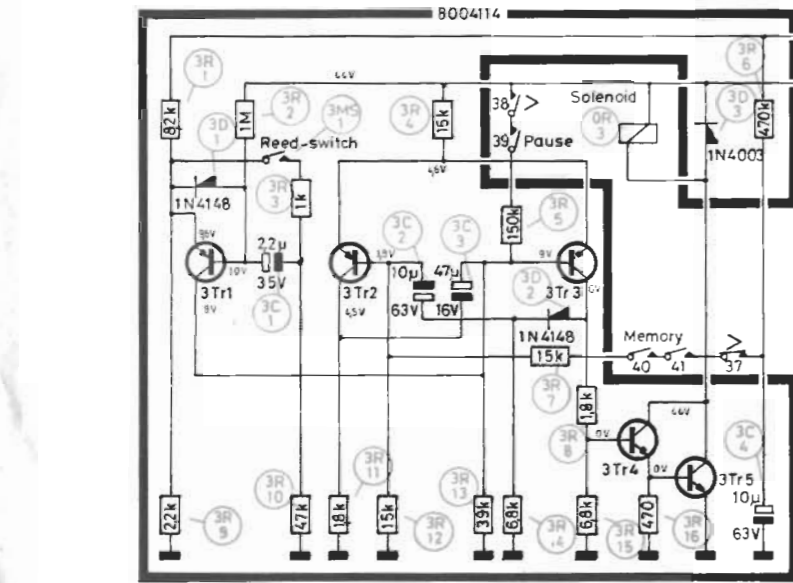
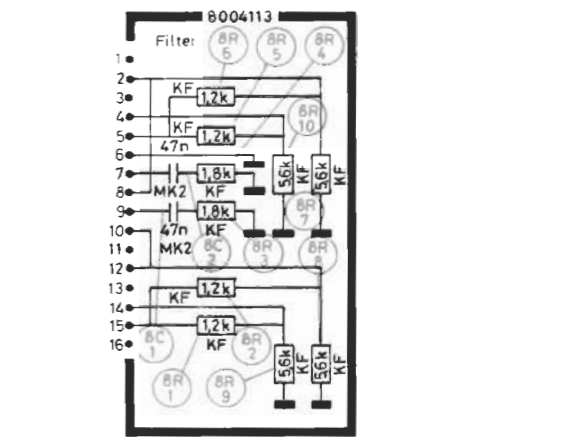
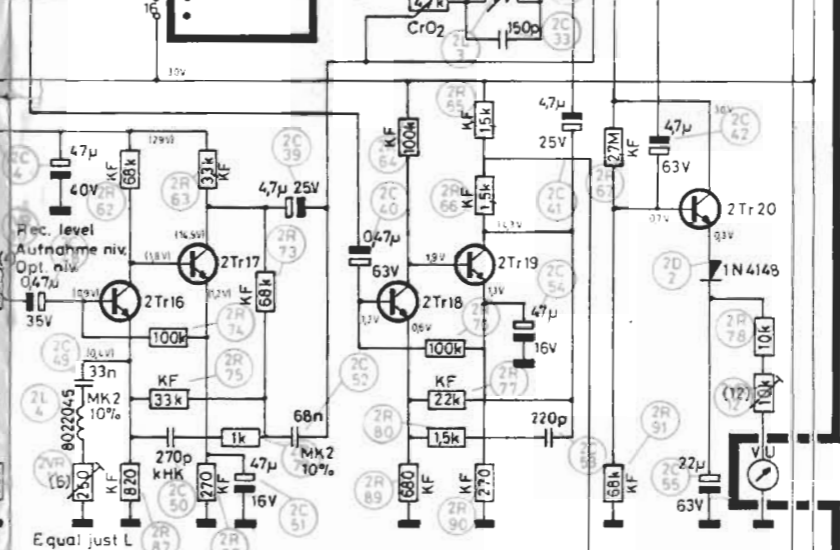
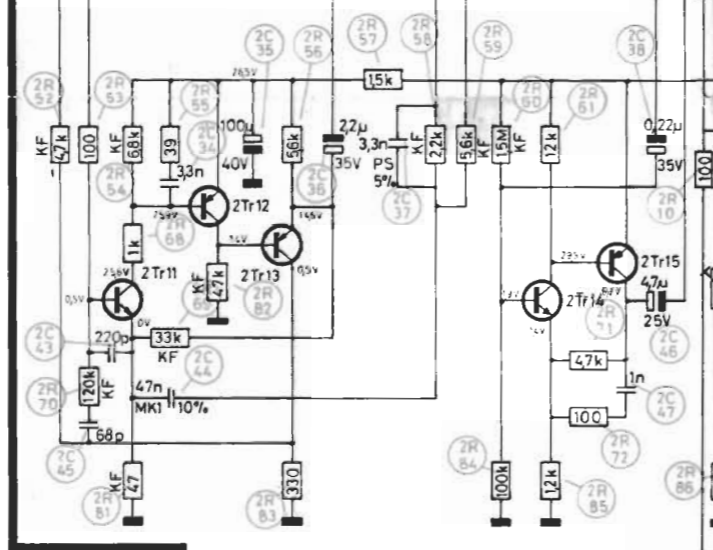
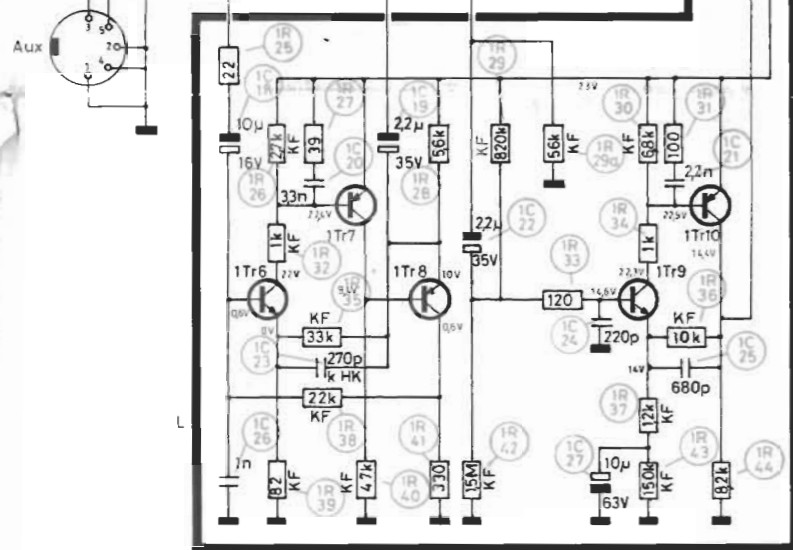
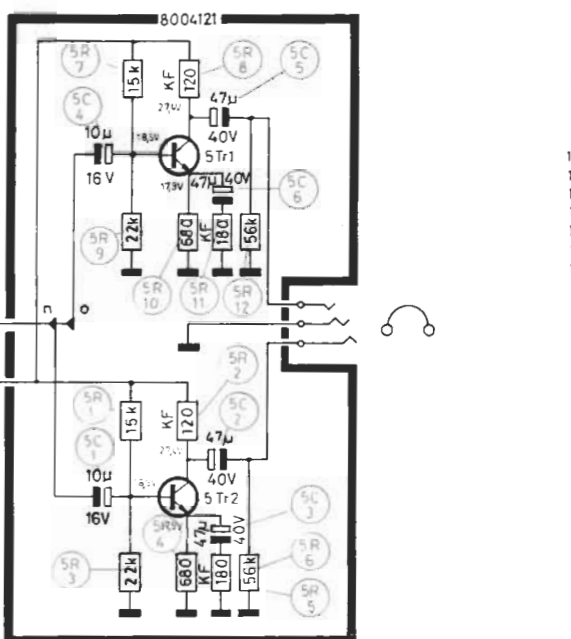
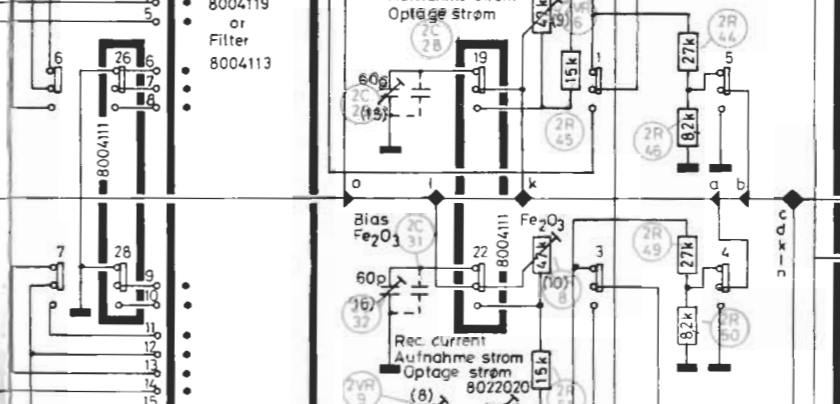
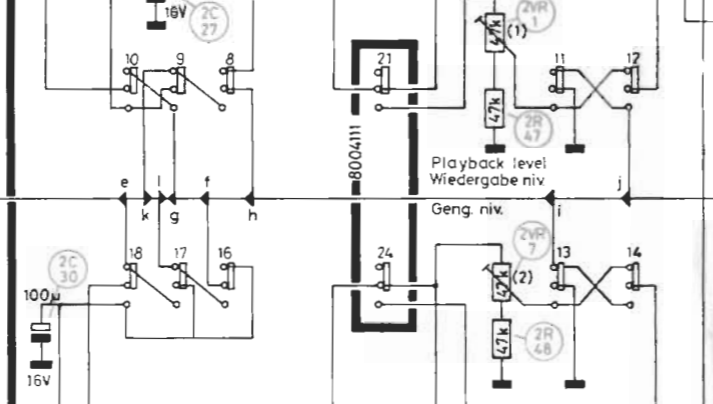
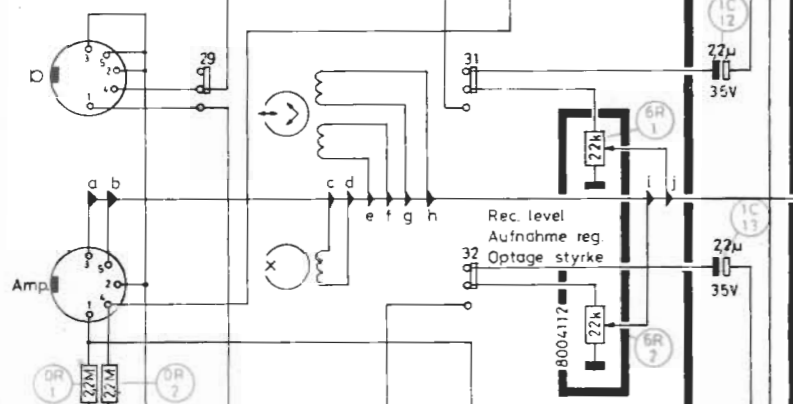

DOLBY UN

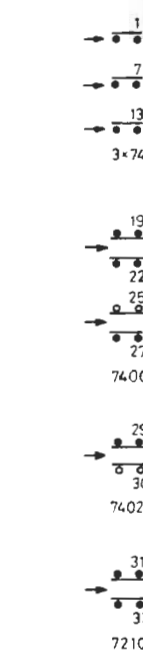

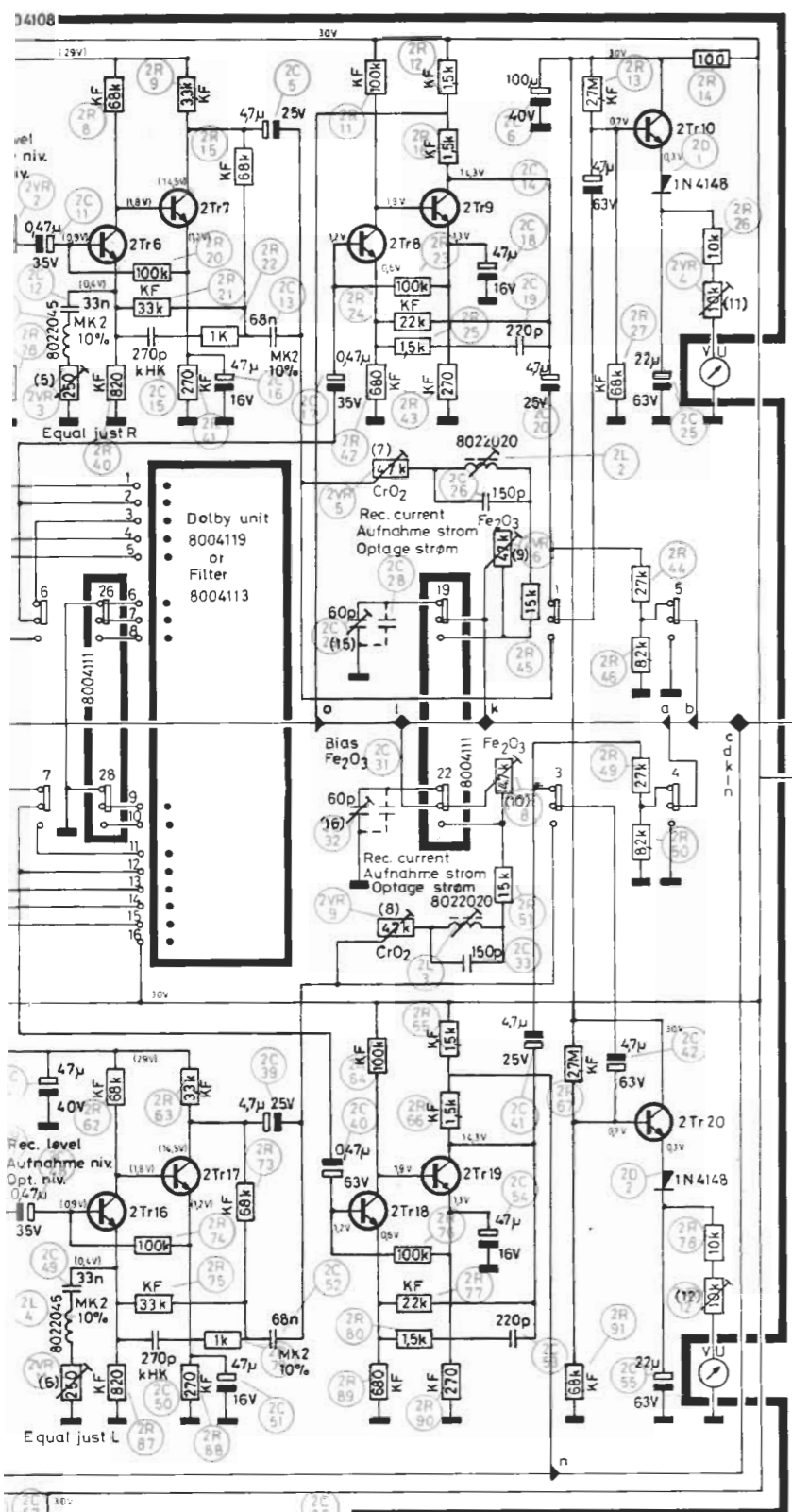

- 1TR1 8320139 2TR5 8320202 2TR19 8320097 7TR1 8320095
- 1TR2 8320069 2TR6 8320097 2TR20 8320285 7TR2 8320095
- 1TR3 8320069 2TR7 8320097 2TR21 8320137 7TR3 8320095
- 1TR4 8320095 2TR8 8320097 2TR22 8320137 7TR4 8320290
- 1TR5 8320069 2TR9 8320097 2TR23 8320097 7TR5 8320095
- 1TR6 8320139 2TR10 8320285 2TR24 8320241 7TR6 8320202
- 1TR7 8320069 2TR11 8320139 3TR1 8320069 7TR7 8320221
- 1TR8 8320069 2TR12 8320069 3TR2 8320069 7TR8 8320095
- 1TR9 8320095 2TR13 8320069 3TR3 8320069 7TR9 8320095
- 1TR10 8320069 2TR14 8320097 3TR4 8320137 7TR10 8320095
- 2TR1 8320139 2TR15 8320202 7TR11 8320290
- 2TR2 8320069 2TR16 8320097 7TR12 8320095
- 2TR3 8320069 2TR17 8320097 7TR13 8320202
- 2TR4 8320097 2TR18 8320097 7TR14 8320221

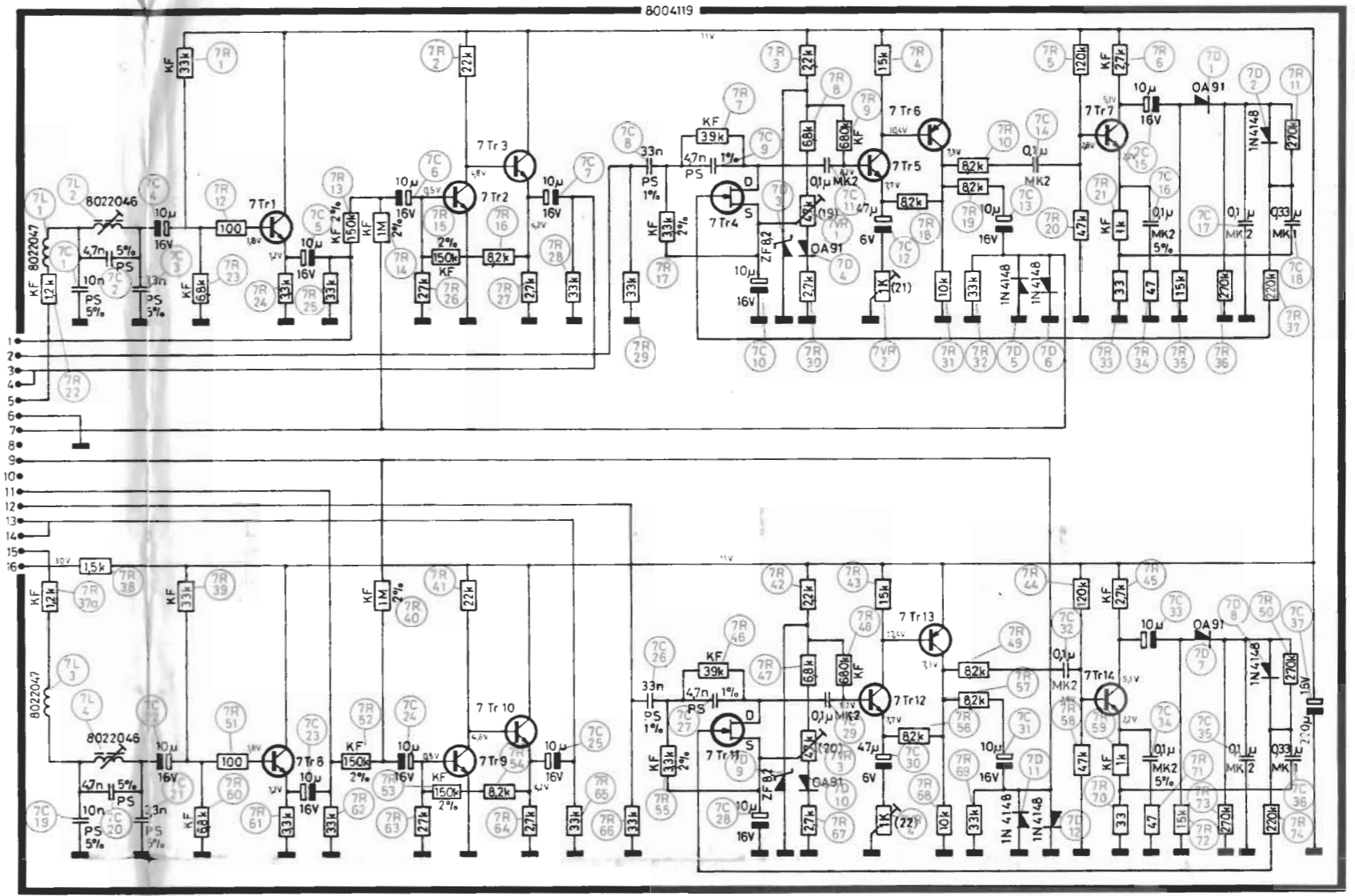
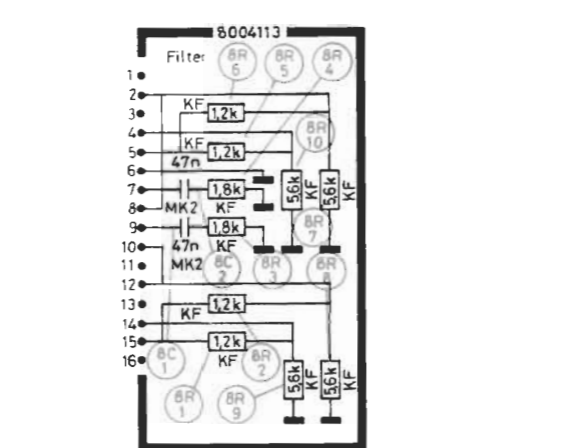
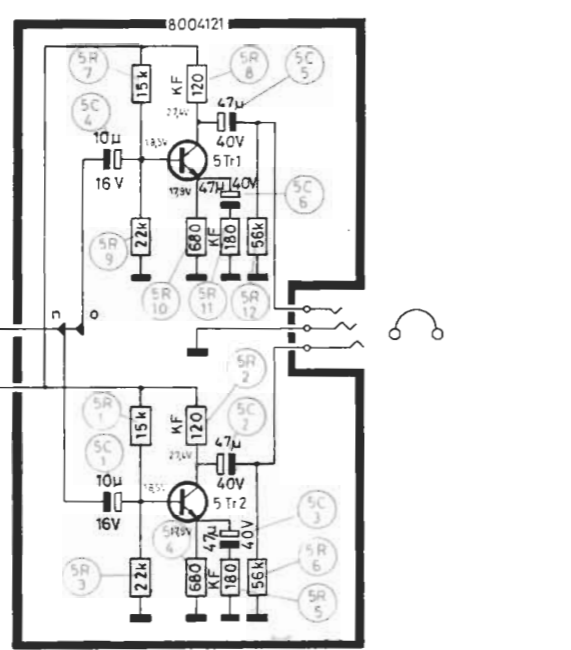

DOLBY UNIT

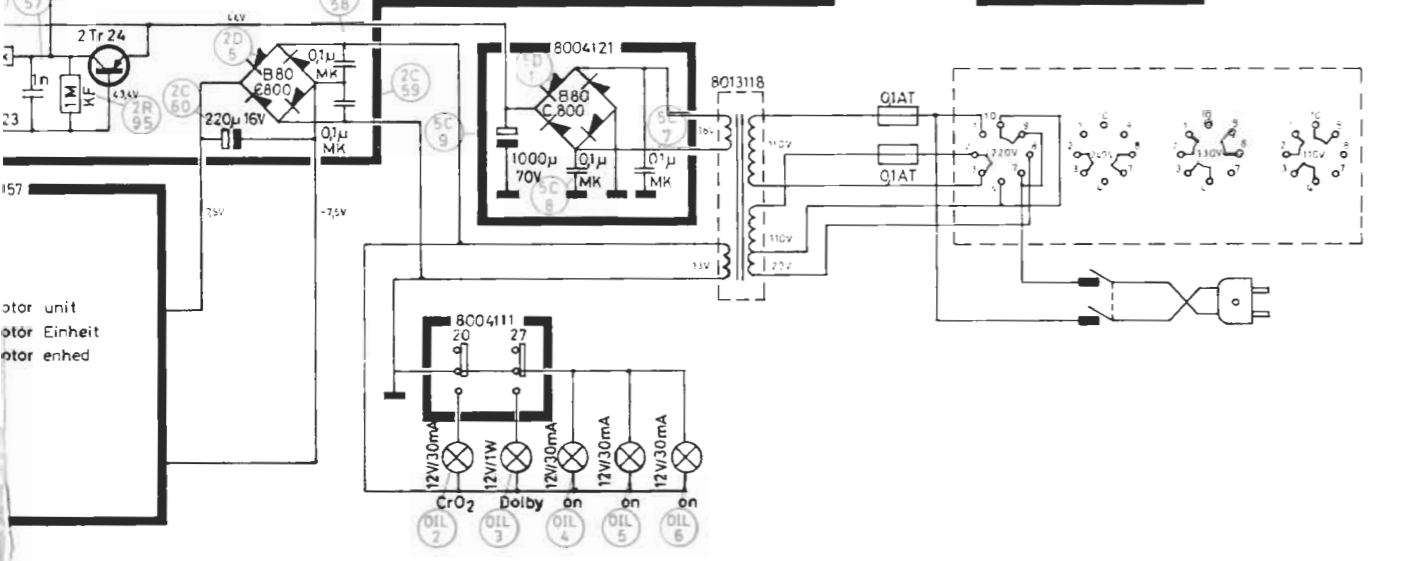
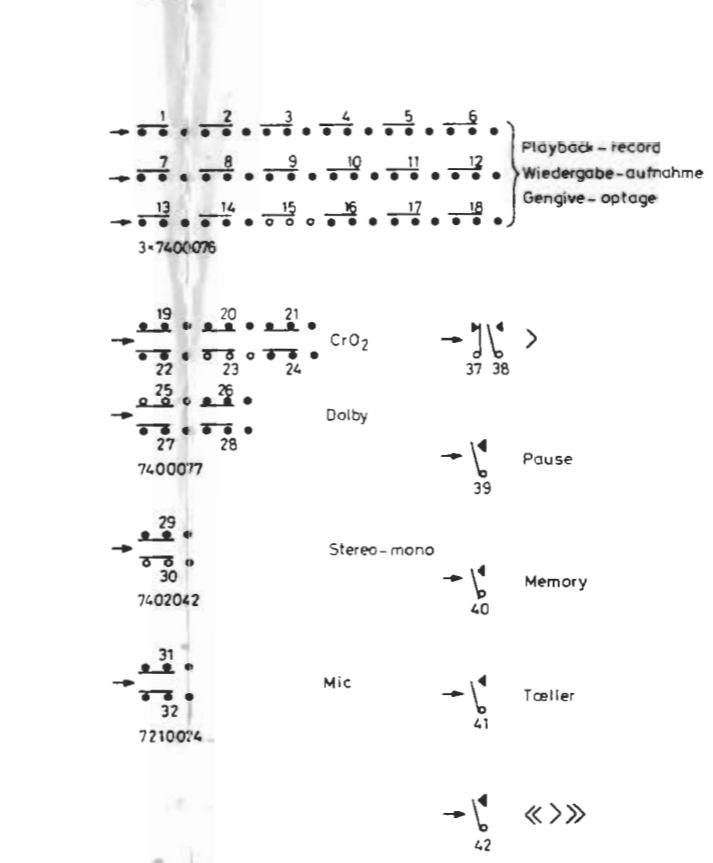

8320069	BC 154	BC 179B BC 263B	BC 159B	BC 259B BC 214BL	BC 253B			
8320095		BC 109B	BC 149B	BC 169B BC 184BL	BC 173 B BC 239B			
8320097	BC 207B	BC 107B	BC 147B	BC 167B BC 182BL	BC 237 B			
8320137					BC 182 BK			
8320139					BC 184 K			
8320202	BC 154	BC 177A BC 261A	BC 157A	MPS 6518 BC 212AL BC 257A				
8320221			BC 149C					
8320241						BD 138		
8320285					BC 547C BC 183 C			
8320290								2N 545B
8320292						BD 137		