

# Bang & Olufsen

## Tape Deck Version II

Beocord 3500/4500

## Tape Deck Version II

Beocord 3500/4500

Indklæbes i Serviceanvisningen Beocord 4500 (3538714/3538713)  
Paste into Service Manual Beocord 4500 (3538714/3538713)  
In Serviceanleitung Beocord 4500 (3538714/3538713) einkleben  
A coller le Manual d'entretien pour Beocord 4500 (3538714/3538713)

3538772

5-91



## DIAGRAM A (AF and Control)

8004869

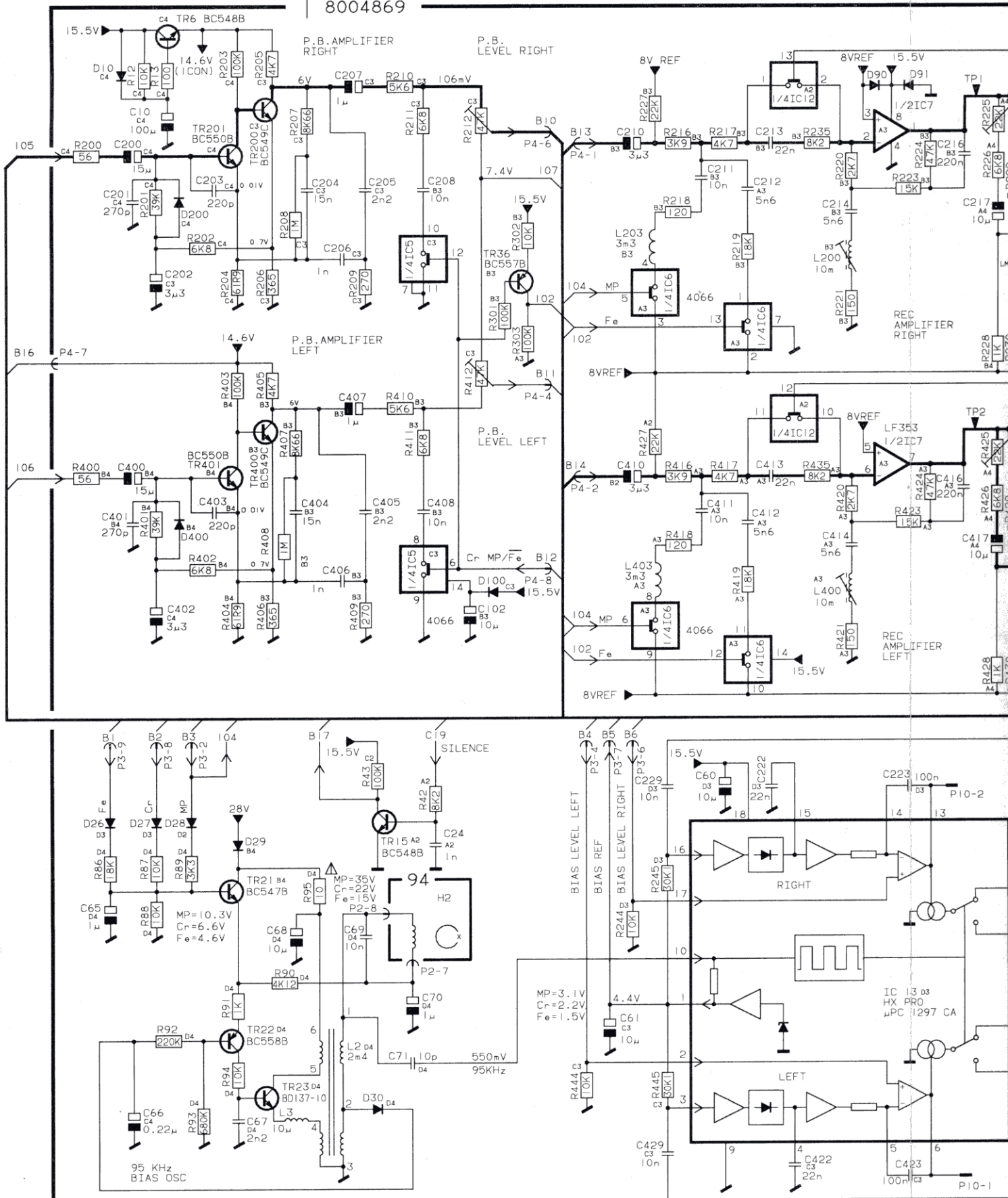

(XCON.) = NUMBER OF VOLTAGE CONNECTIONS

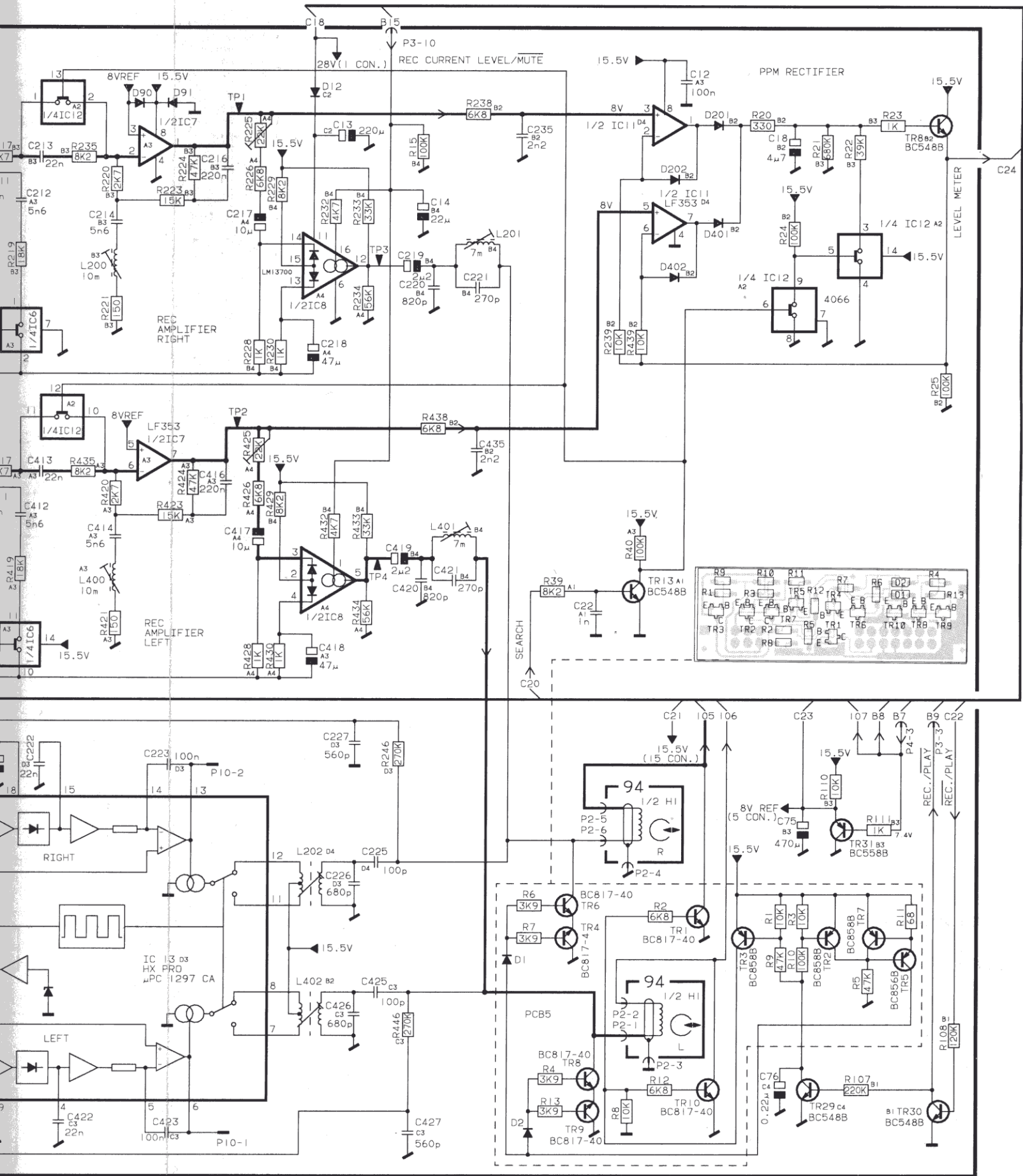
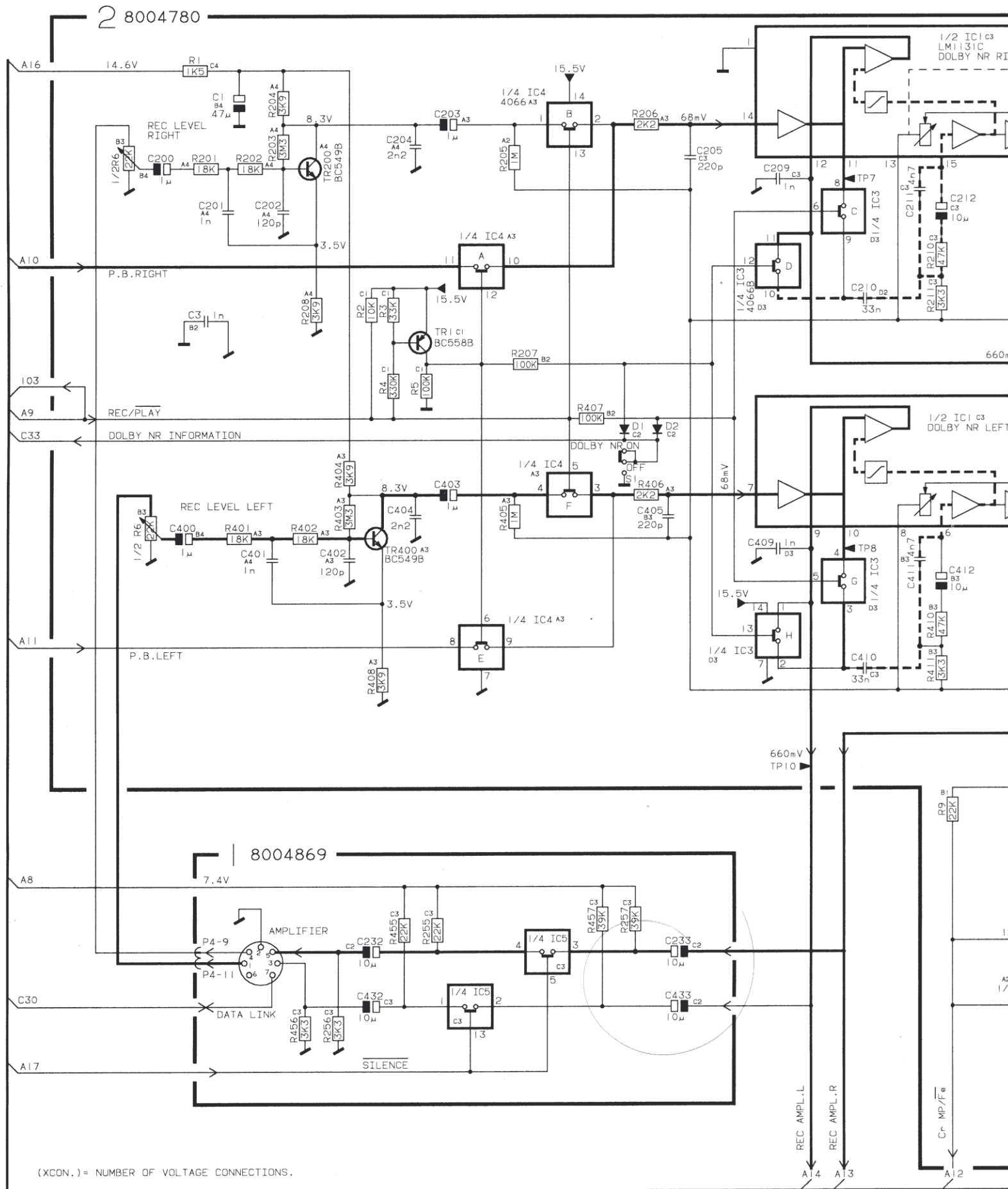
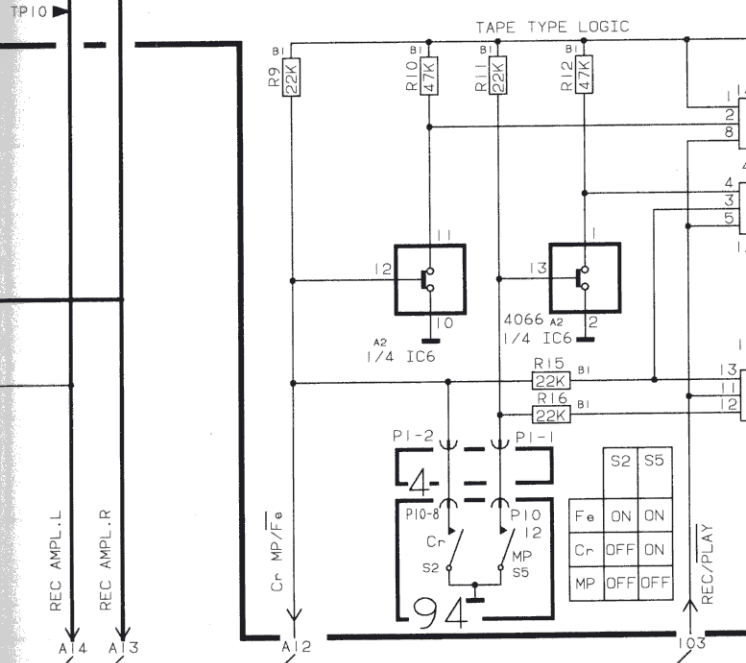
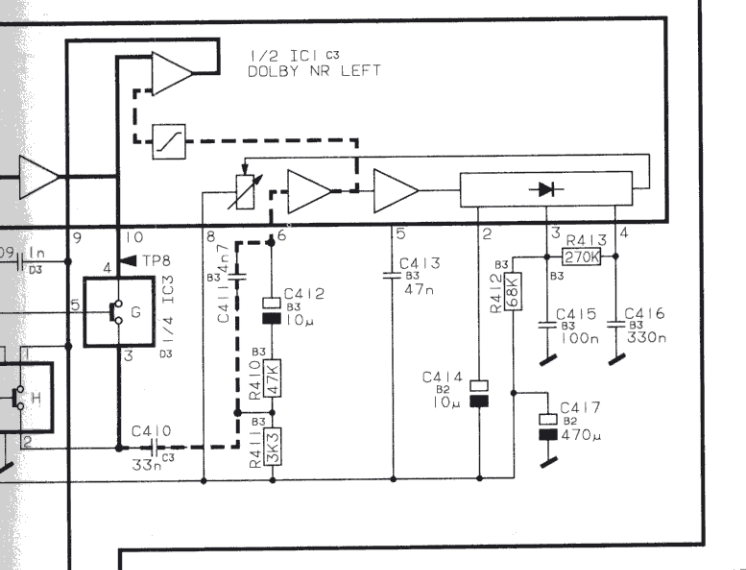
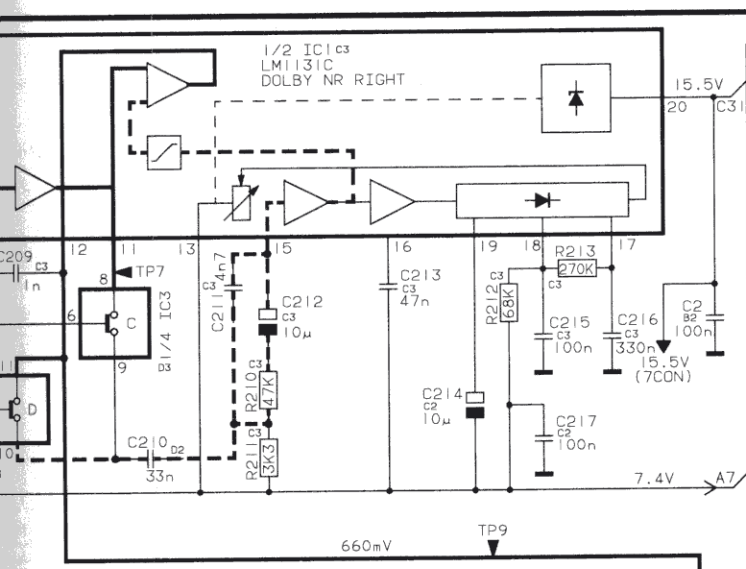

DIAGRAM B (Dolby NR, Bias Switch and Tape Type Logic)



(XCON.) = NUMBER OF VOLTAGE CONNECTIONS.



NOISE REDUCTION SYSTEM MANUFACTURED UNDER LICENS FROM DOLBY LABORATORIES. LICENSING CORPORATION. THE WORD DOLBY IS A TRADE MARK OF DOLBY LABORATORIES LICENSING CORPORATION.

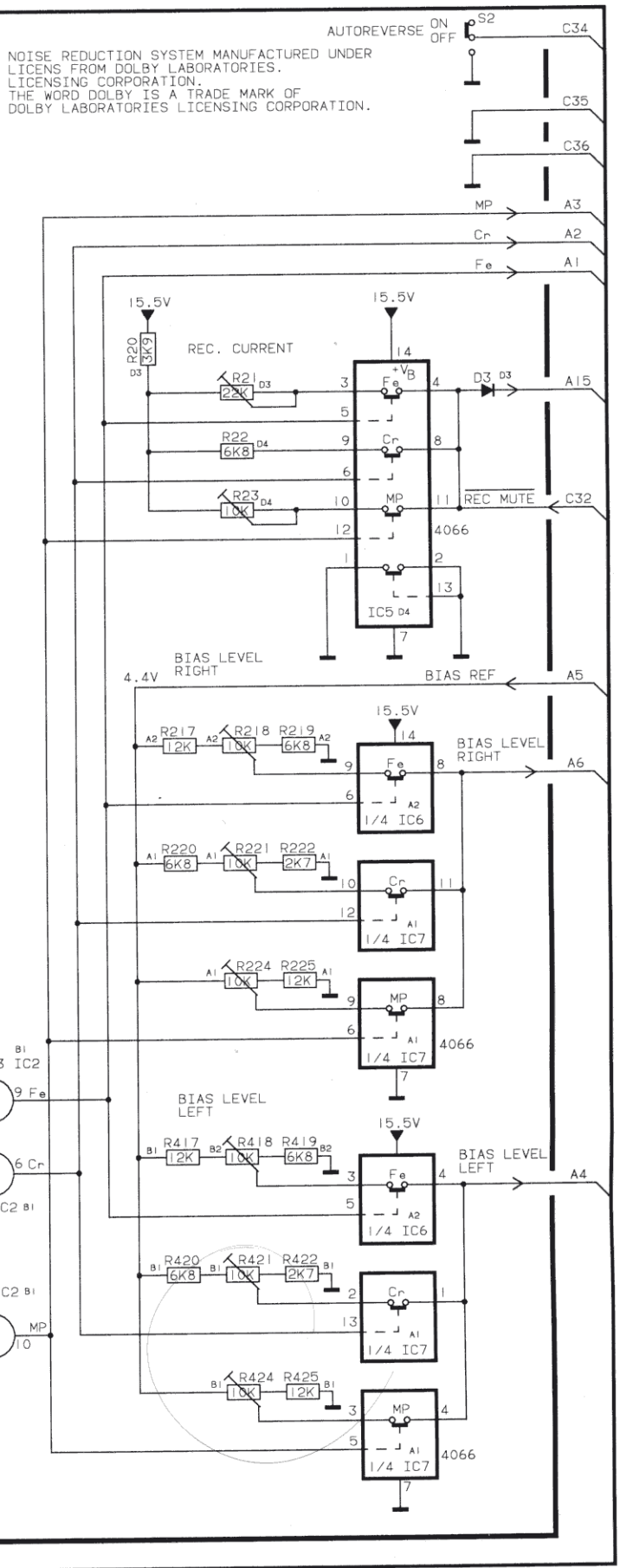

## DIAGRAM C (Control and Operation)

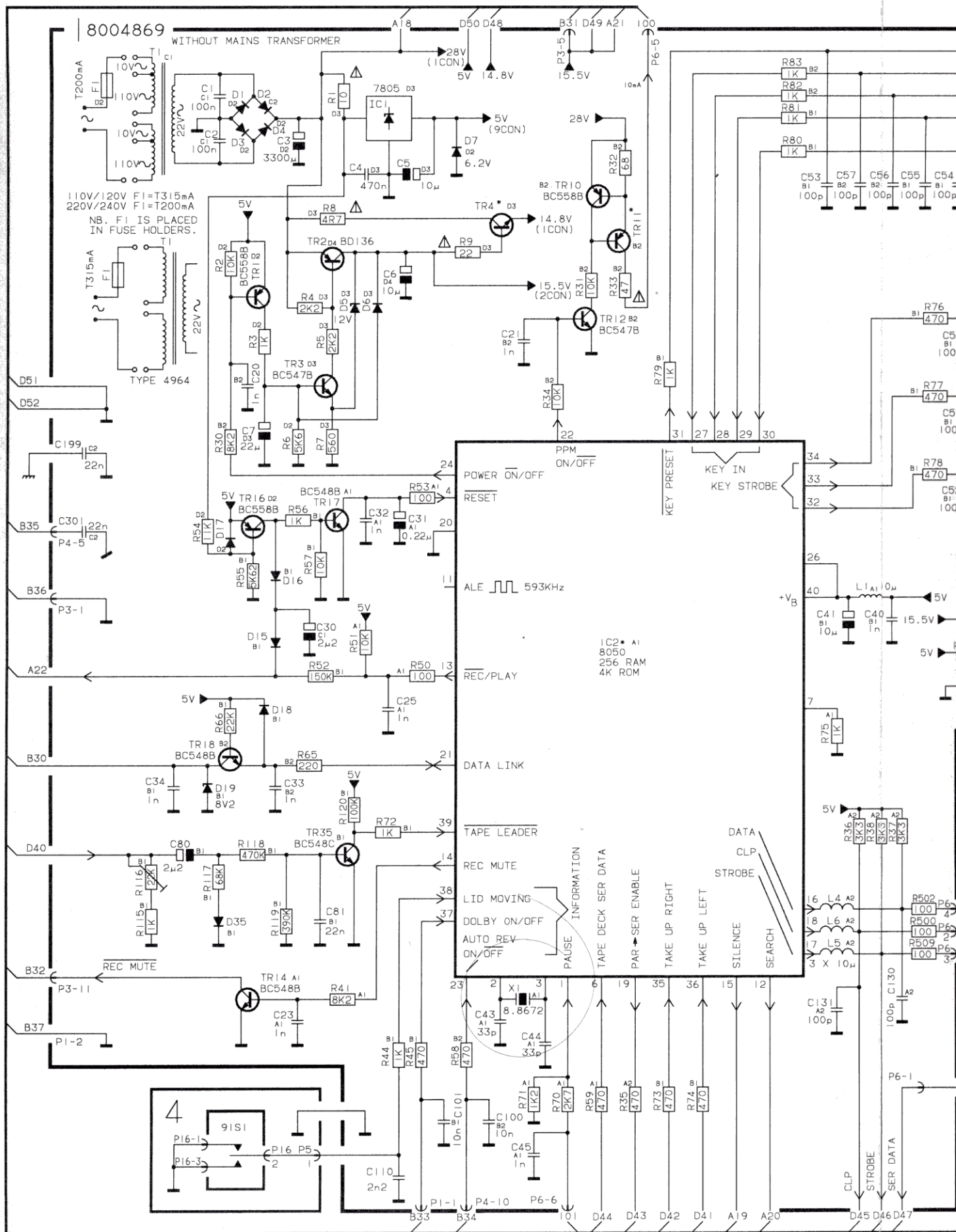

38004782

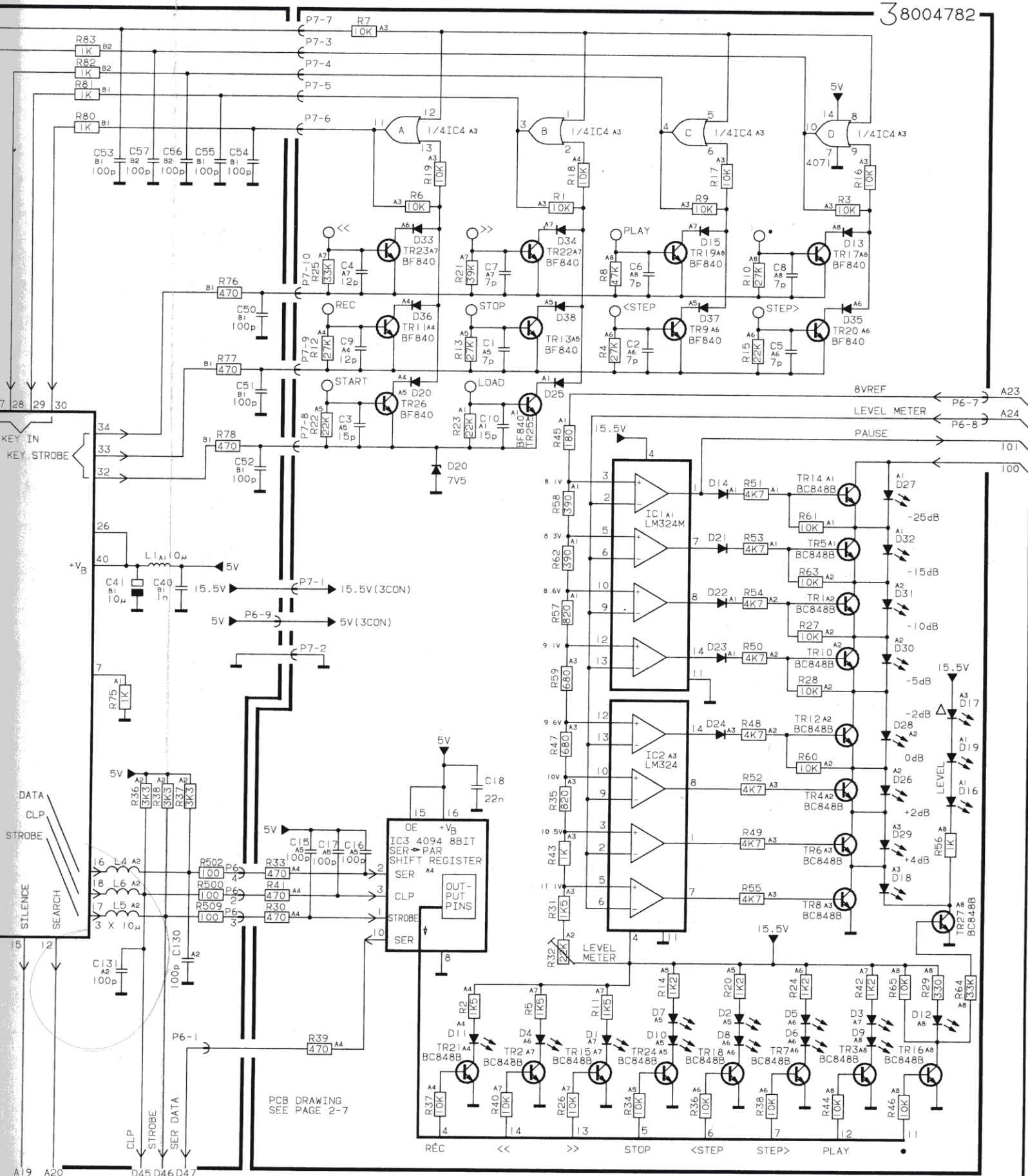

PCB DRAWING  
SEE PAGE 2-7

(XCON.)=NUMBER OF VOLTAGE CONNECTIONS.

DIAGRAM C (Tape Deck Control)

