

Bang & Olufsen

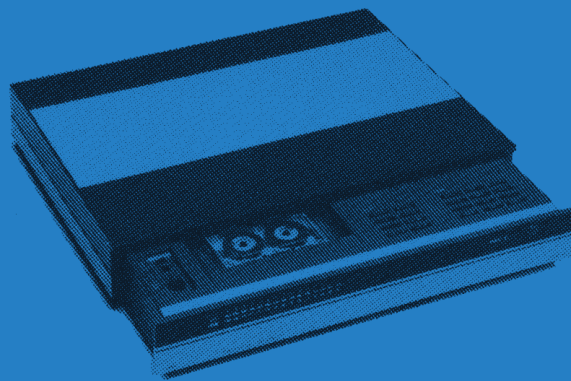

Beocord 5500

Type 4931, 4932, 4933,
4934, 4935

SERVICEANLEITUNG/
MANUEL d'ENTRETIEN



DIAGRAM A (Bias Osc., P.B. Ampl., Rec. Ampl., HX PRO)

8004520

- 1

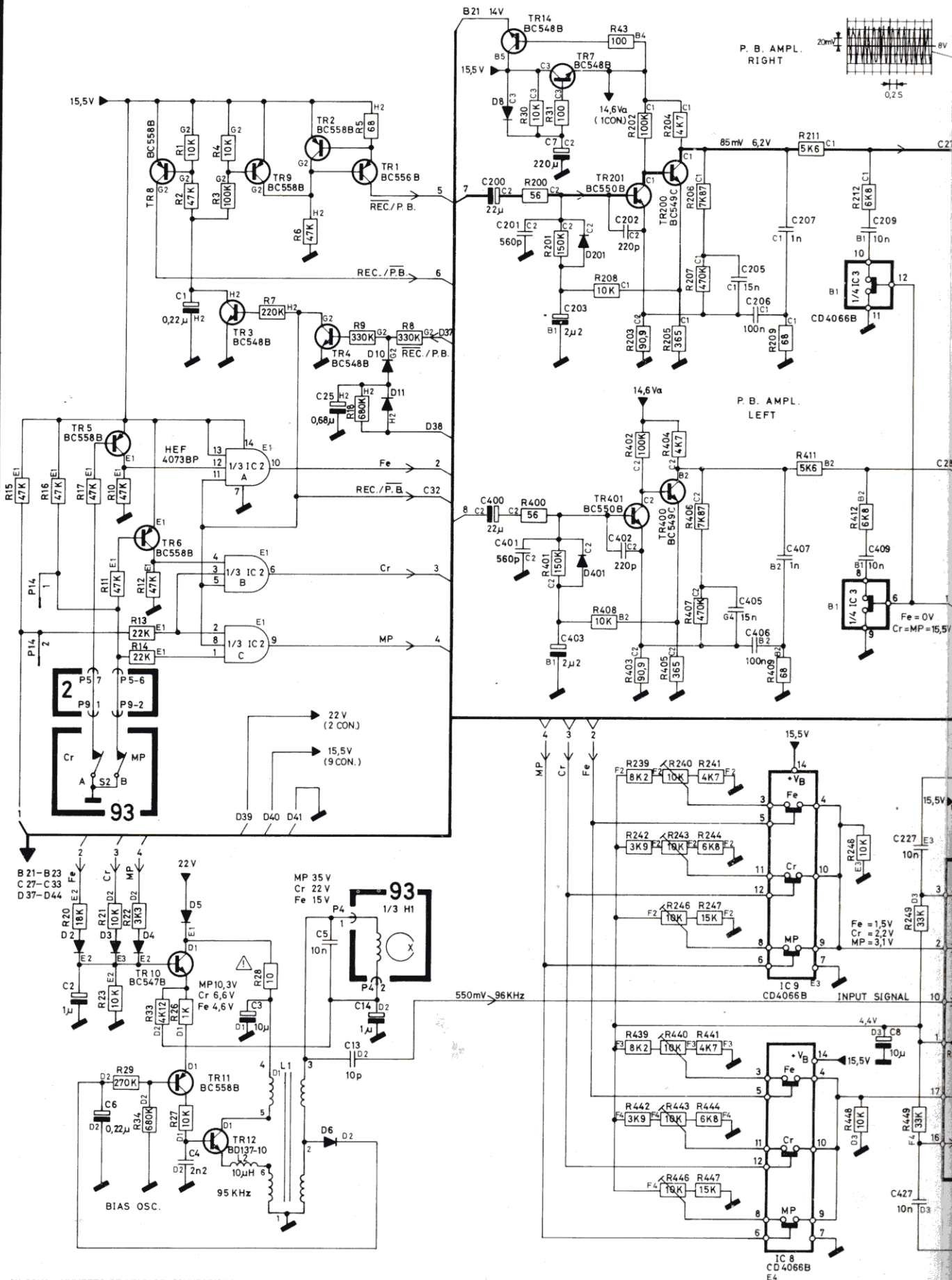

(X CON) = NUMBERS OF VOLTAGE CONNECTIONS.

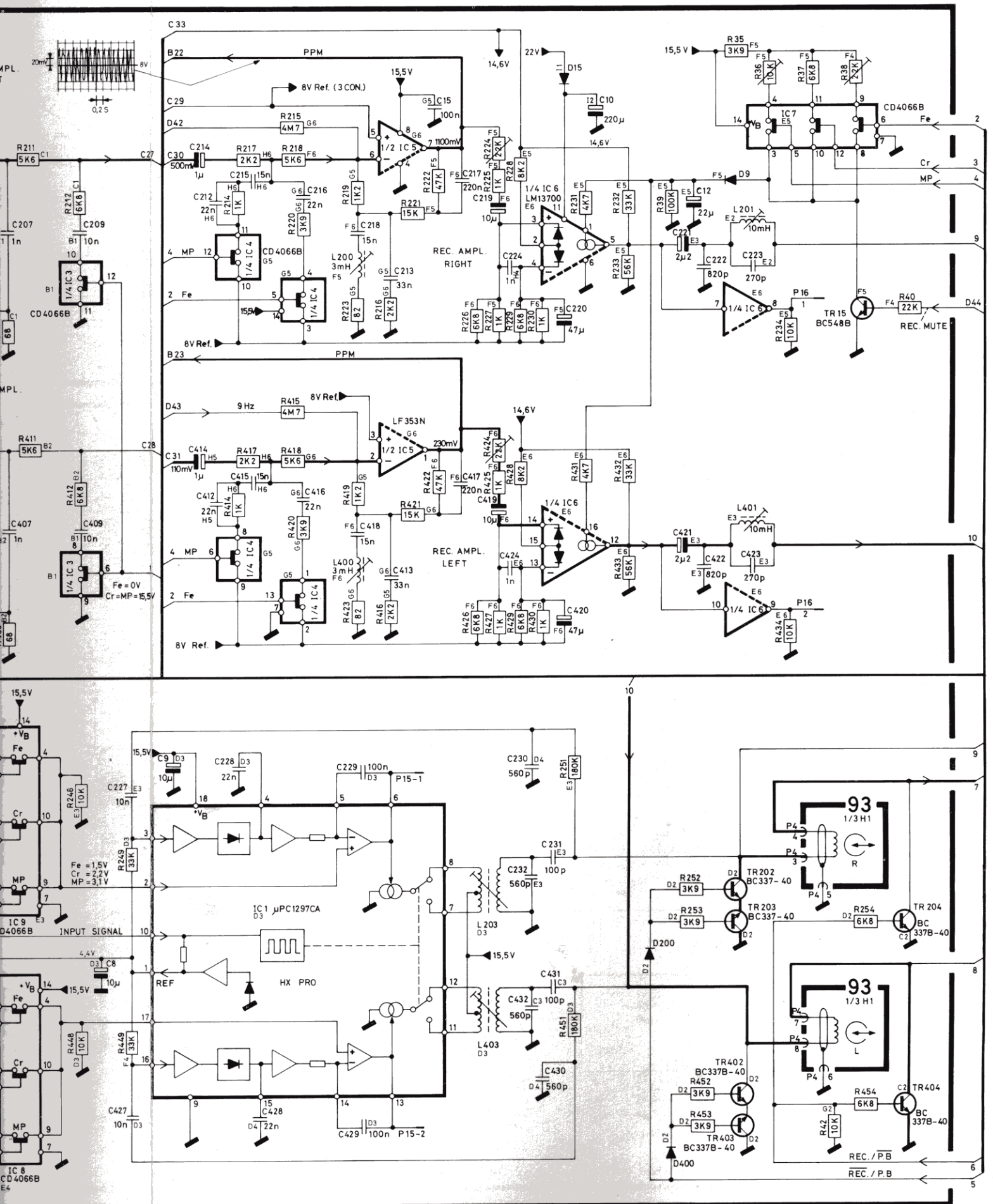
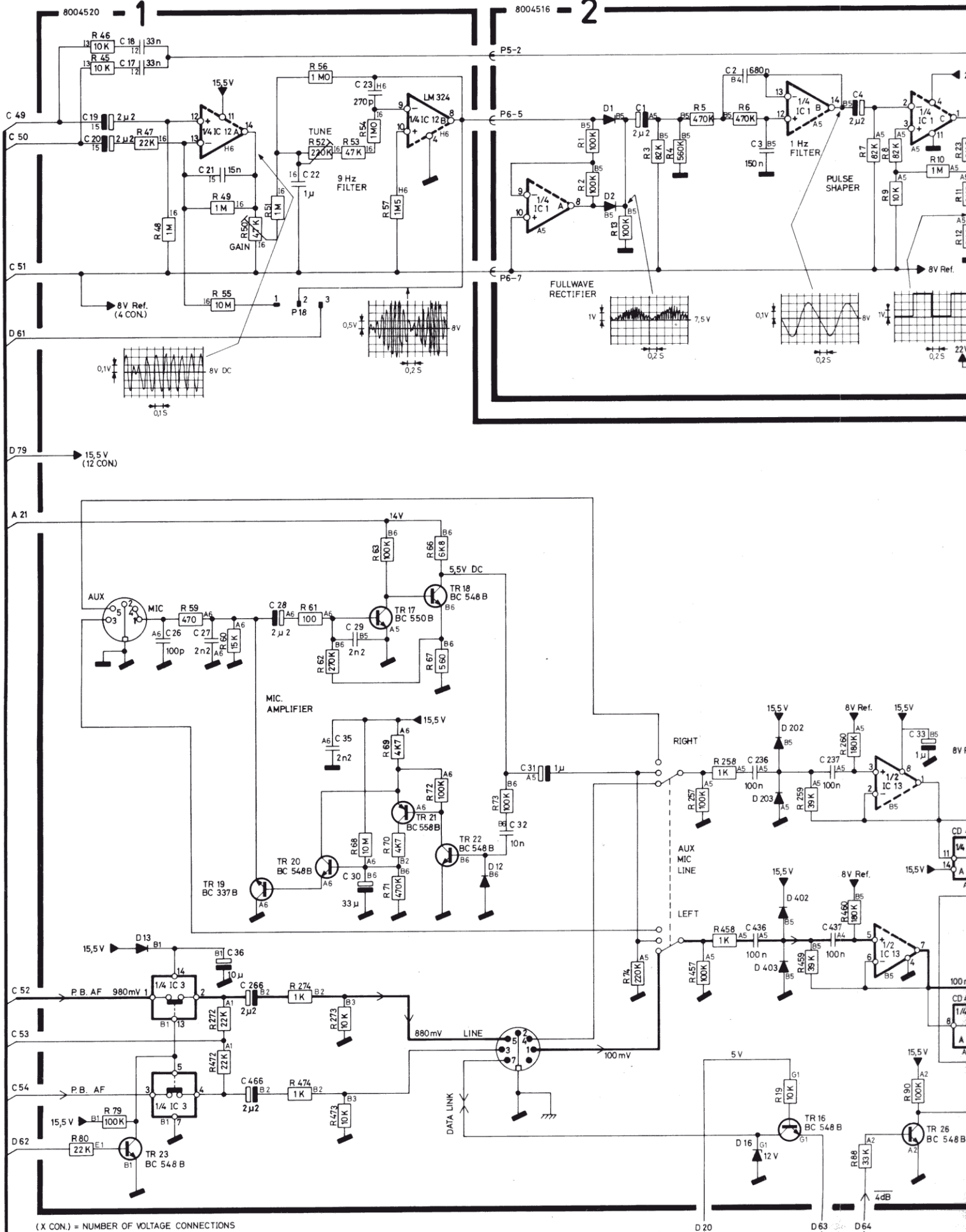
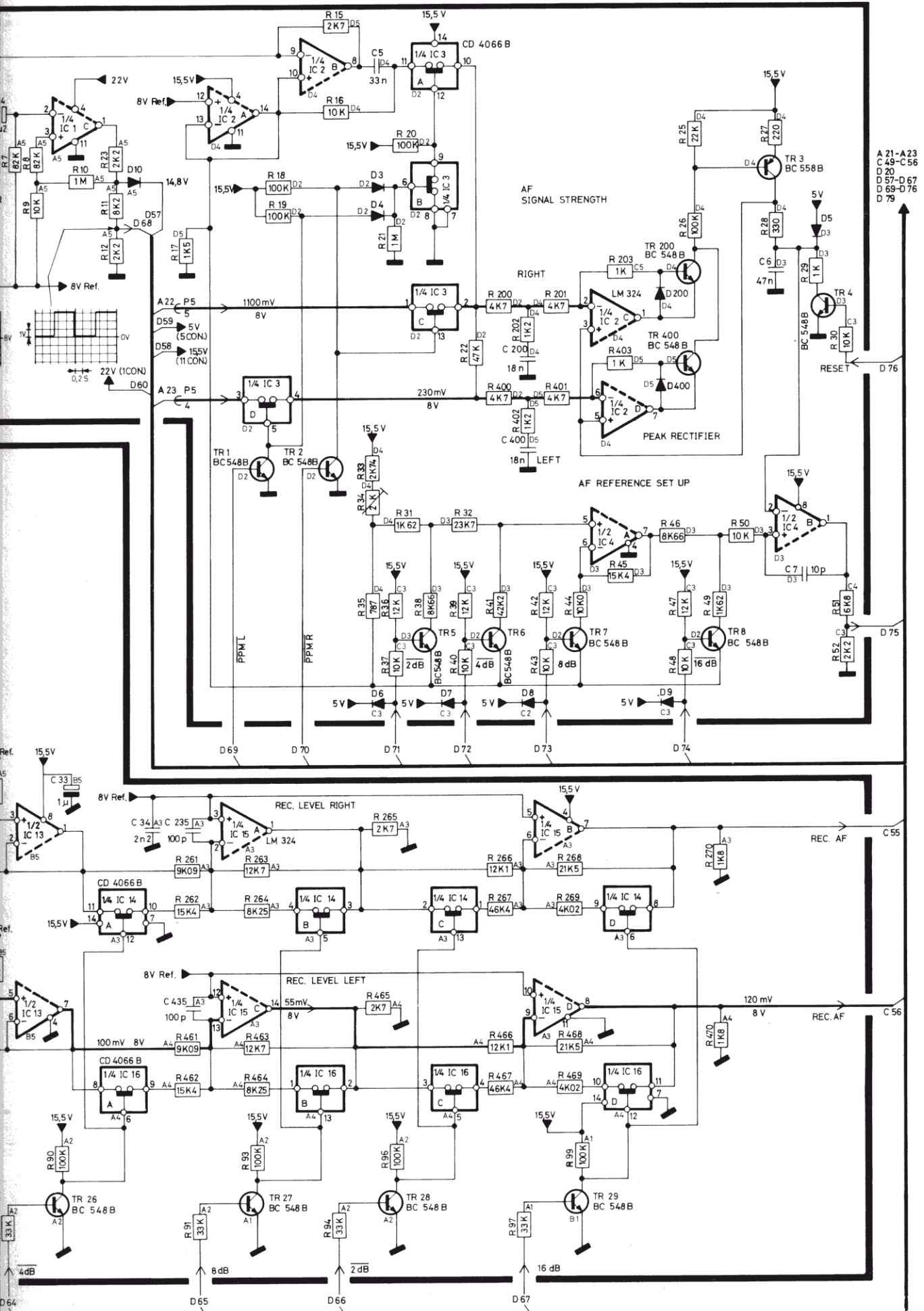

DIAGRAM B (Mic. Ampl., Rec. Level, Signal Strength Sensor)





- A 21-A23
- C 49-C 56
- D 20
- D 57-D 67
- D 69-D 76
- D 79

Ref.

Ref.

64

DIAGRAM C (Dolby NR B, C)

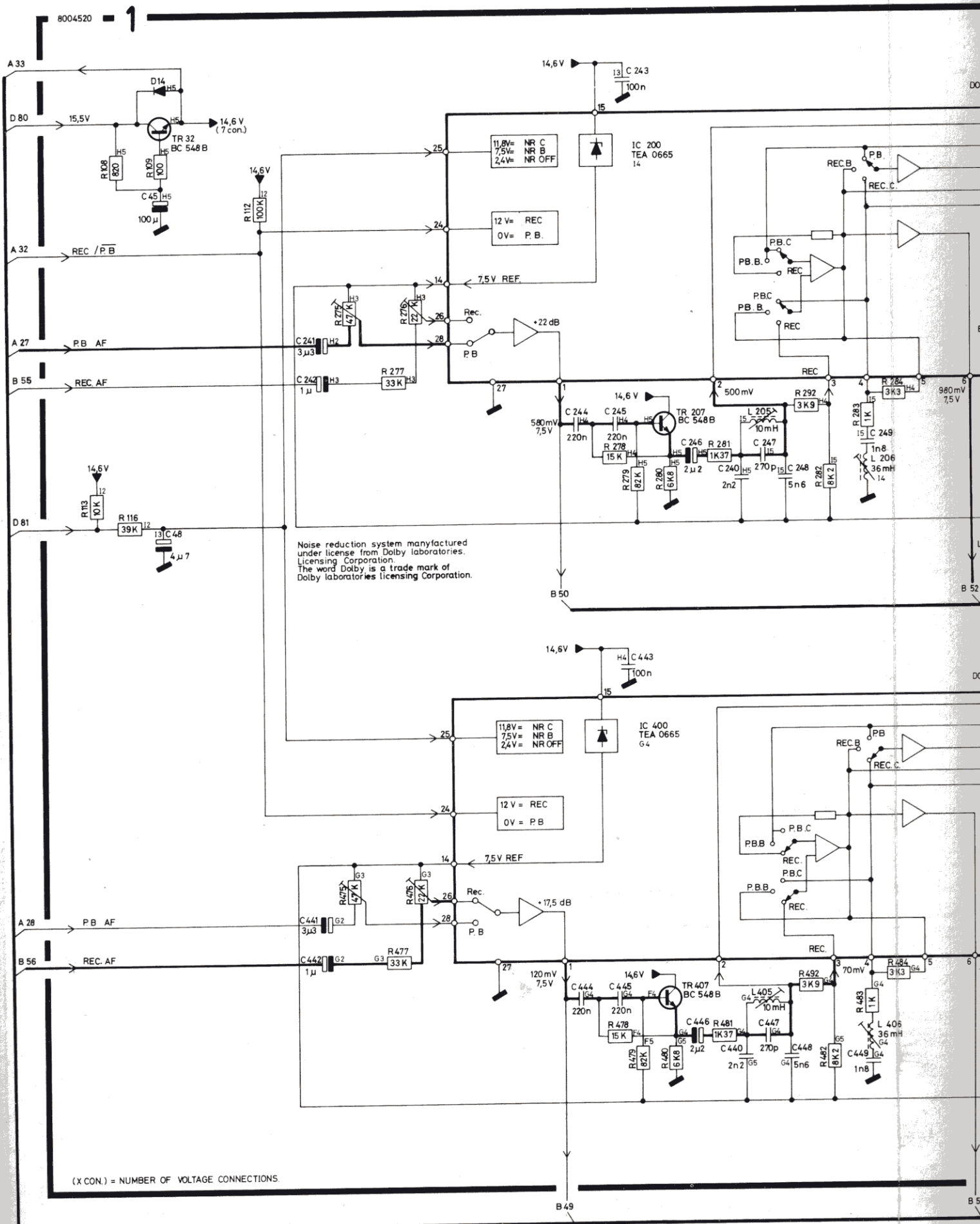

Noise reduction system manufactured under license from Dolby laboratories Licensing Corporation. The word Dolby is a trade mark of Dolby laboratories licensing Corporation.

(X CON.) = NUMBER OF VOLTAGE CONNECTIONS

A 27-A 33
B 49-B 56
D 78
D 80-D 81

DOLBY NR B/C RIGHT

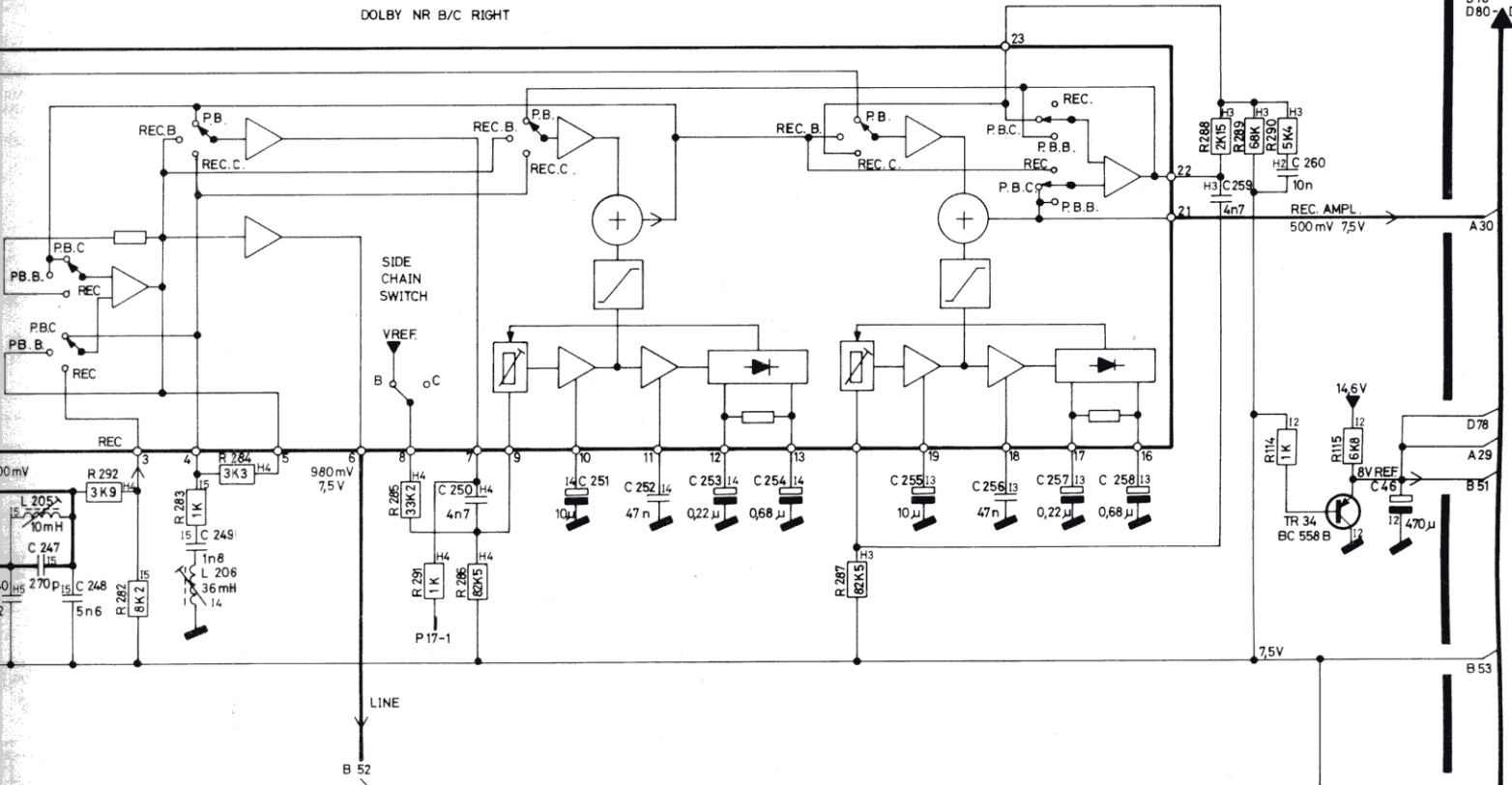

DOLBY NR B/C LEFT

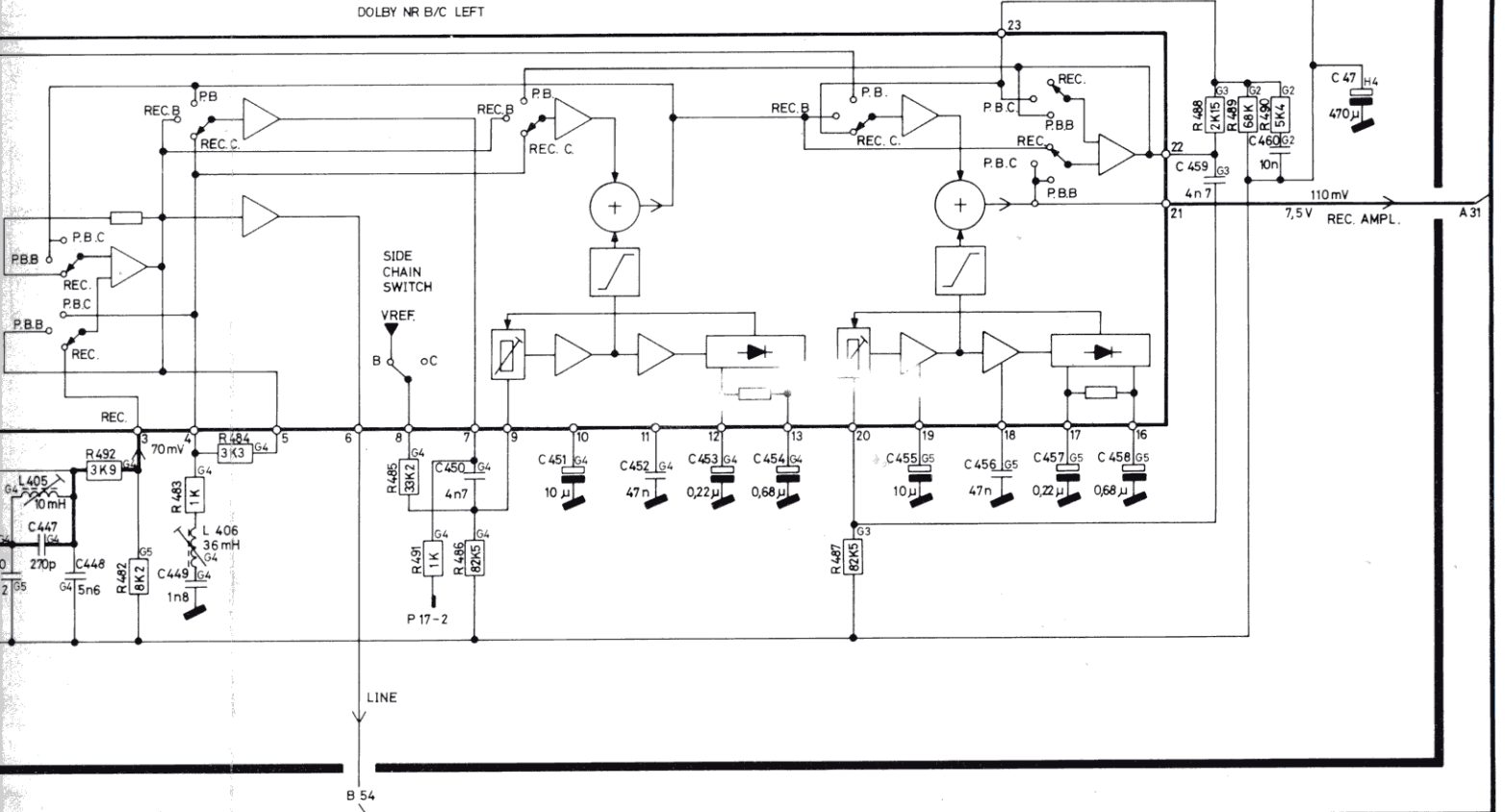
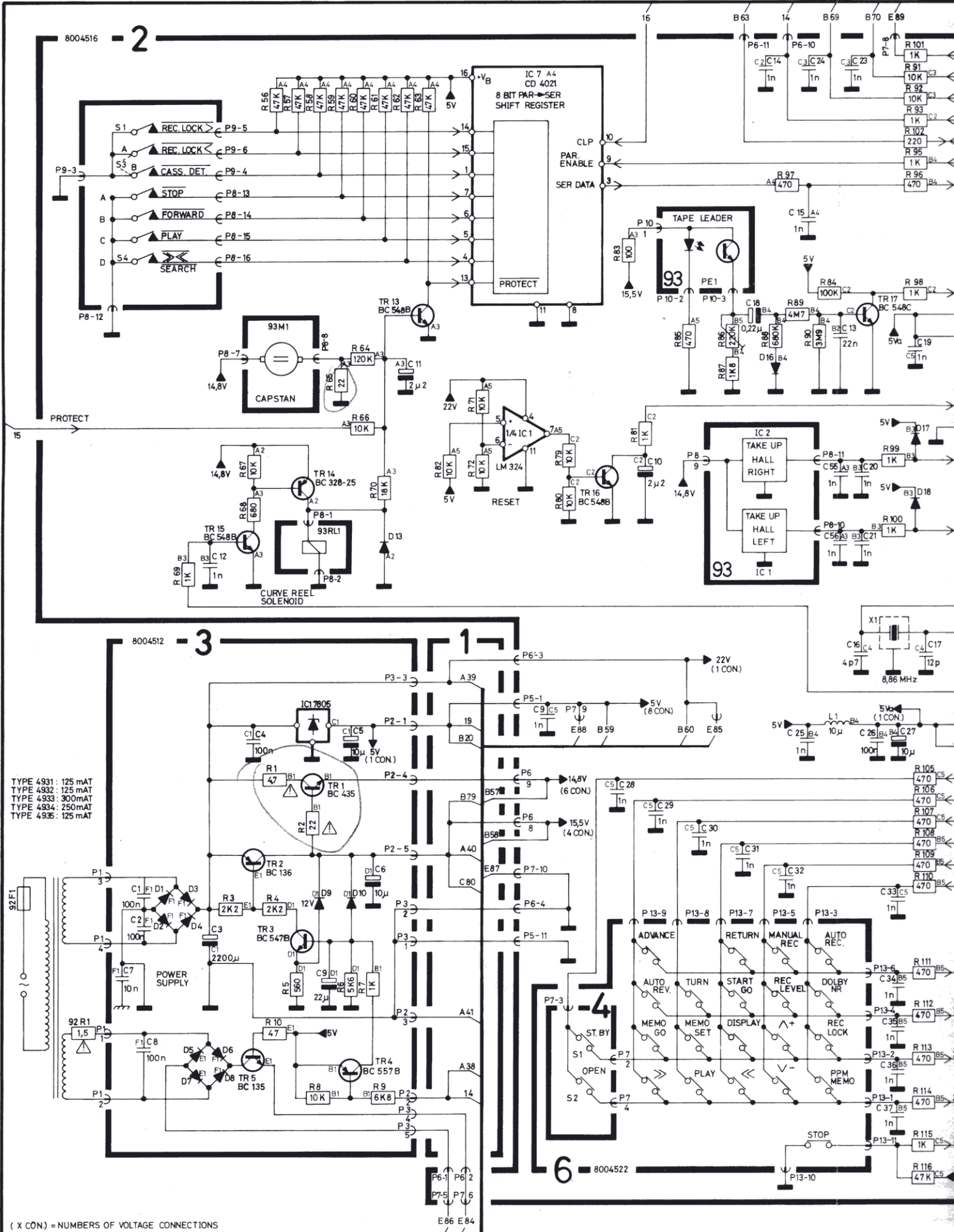
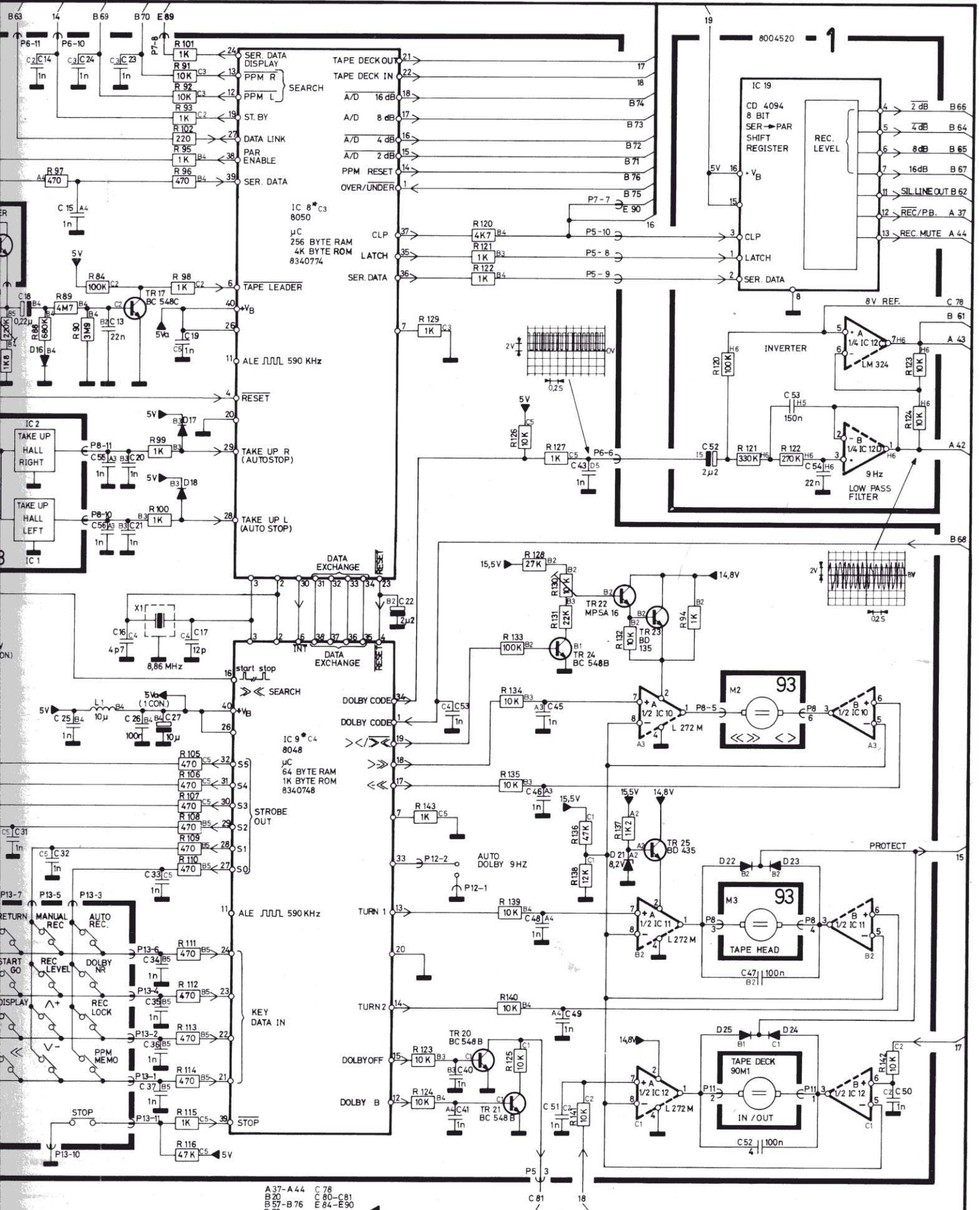

DIAGRAM D (Control Circuits, Power Supply)



(X CON) = NUMBERS OF VOLTAGE CONNECTIONS



A37-A44 C 78
 B57-B76 C 80-C81
 B 79 E 84-E90

DIAGRAM E (Display)

