

Bang & Olufsen

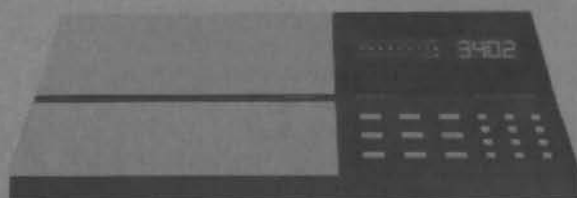

BEOCORD 6000

Type 4831-4832-4833-
4834-4835-4836-4837

BEOCORD 8002

Type 4841-4842-4843-
4844-4845-4846-4847



1 Microcomputer and display

2 Rec. Dolby NR

3 Play back. Bias

4 Power Supply

5 Power Unit

6 Rectifier

7 Operating Unit

8 Mic. and Input Amplifier

10 Clock-set

13 Bias Osc.

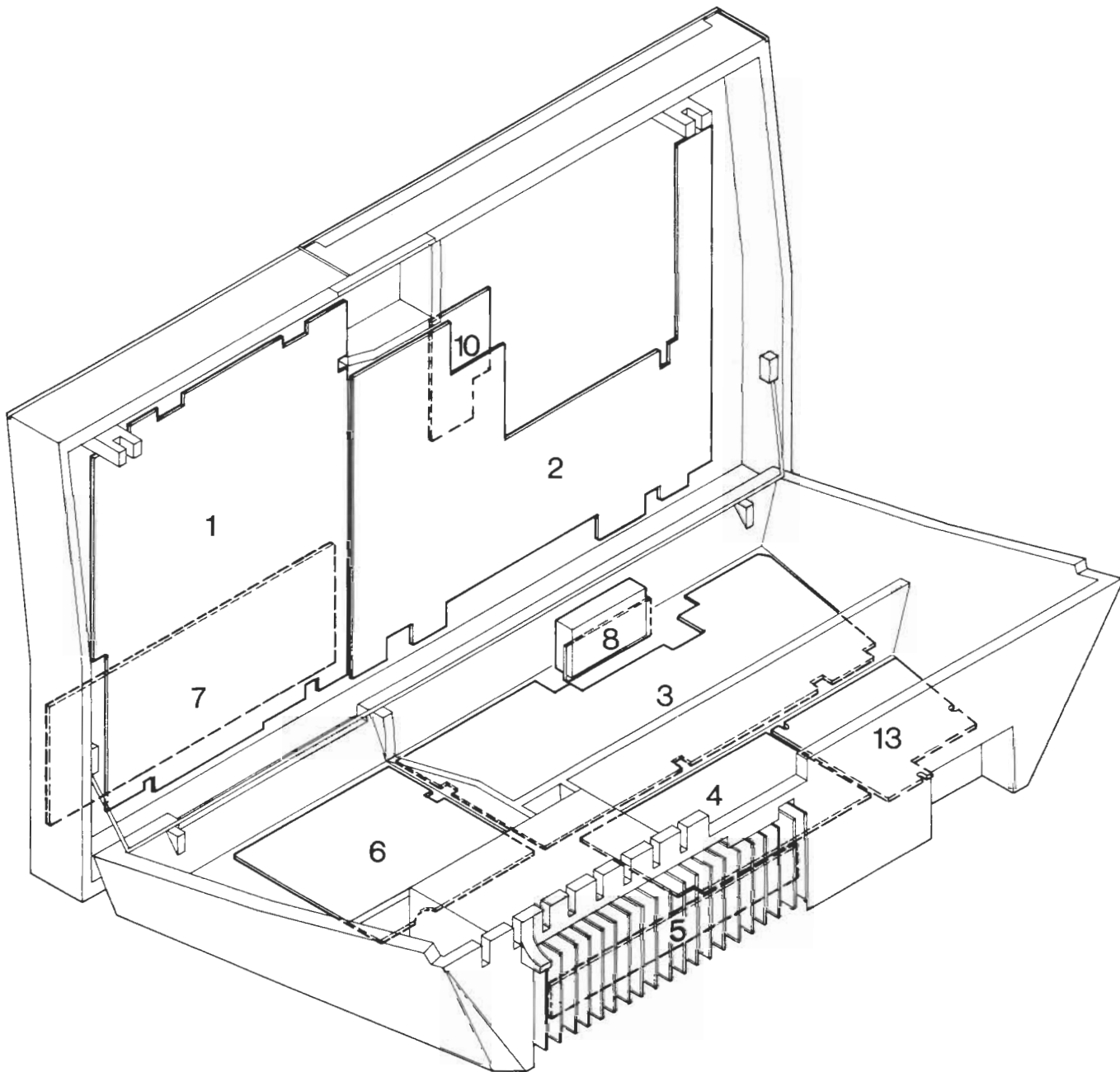

MEASURING CONDITIONS

All DC voltages have been measured in relation to ground with voltmeter with an input resistance of 11 Mohms.

Oscillograms and AC voltages have been measured in relation to ground with oscilloscope or voltmeter with an input resistance of 1 Mohm.

Voltages: Position play back (333 Hz 250 pWb)

AC voltages stated in millivolts (mV). Ex.: 733 mV.

DC voltages stated in volts (V). Ex.: 0.7 V.

The signal path in recording pos. is shown in left channel, and replay pos. is shown in right channel.

EXPLANATION TO DIAGRAM

The wire connections have been gathered into »bundles« in the diagram. The individual wire is provided with codes indicating where they lead to.

INTERNAL CONNECTION ON A DIAGRAM PAGE

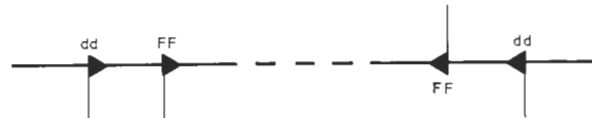

indicating by two identical letters (capital or small).

CONNECTION TO ANOTHER DIAGRAM PAGE

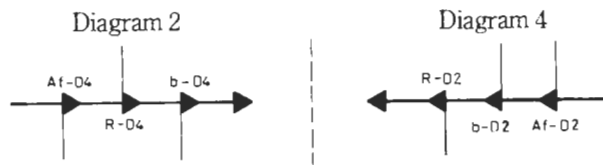

indicated by a letter (capital or small) and a diagram (D) number or by a small and a capital letter together with a diagram (D) number.

GROUND SYMBOLS

Two different ground symbols are used in the set.

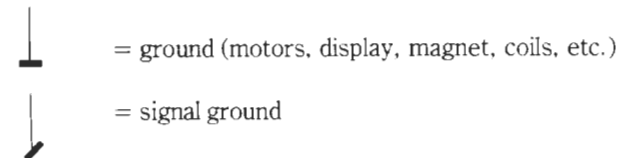

Signal voltages must be measured in relation to signal ground in order to obtain correct result.

CO-ORDINATE NUMBERS

The biggest PC boards are provided with co-ordinate systems. The components on these PC boards are provided with a co-ordinate number on the diagram (smaller printing type than the position numbers) indicating in which co-ordinate they are placed on the PC board.

DIAGRAM 1 FOR BEOCORD 6000

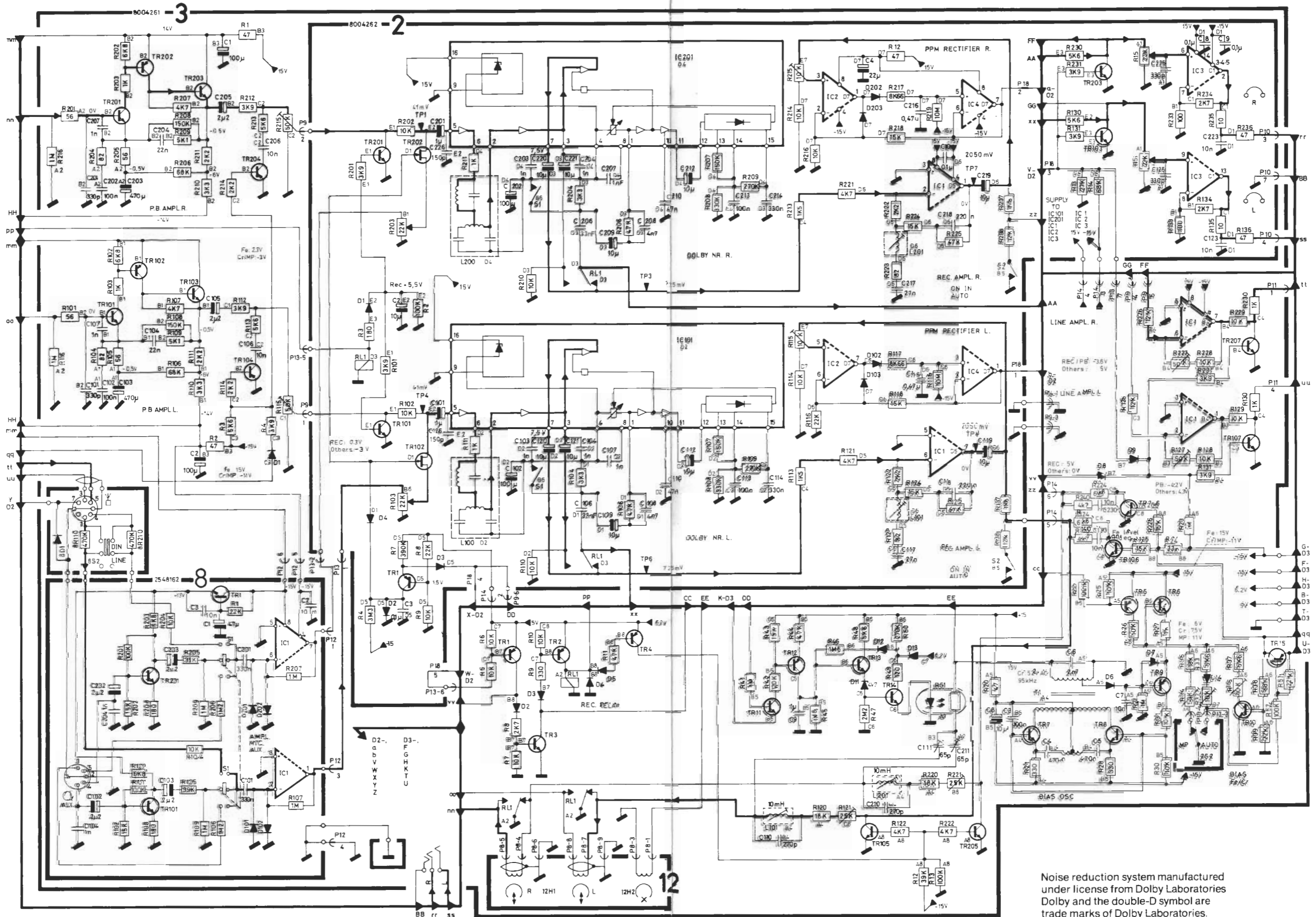

Noise reduction system manufactured under license from Dolby Laboratories. Dolby and the double-D symbol are trade marks of Dolby Laboratories.

DIAGRAM 2 FOR BEOCORD 6000

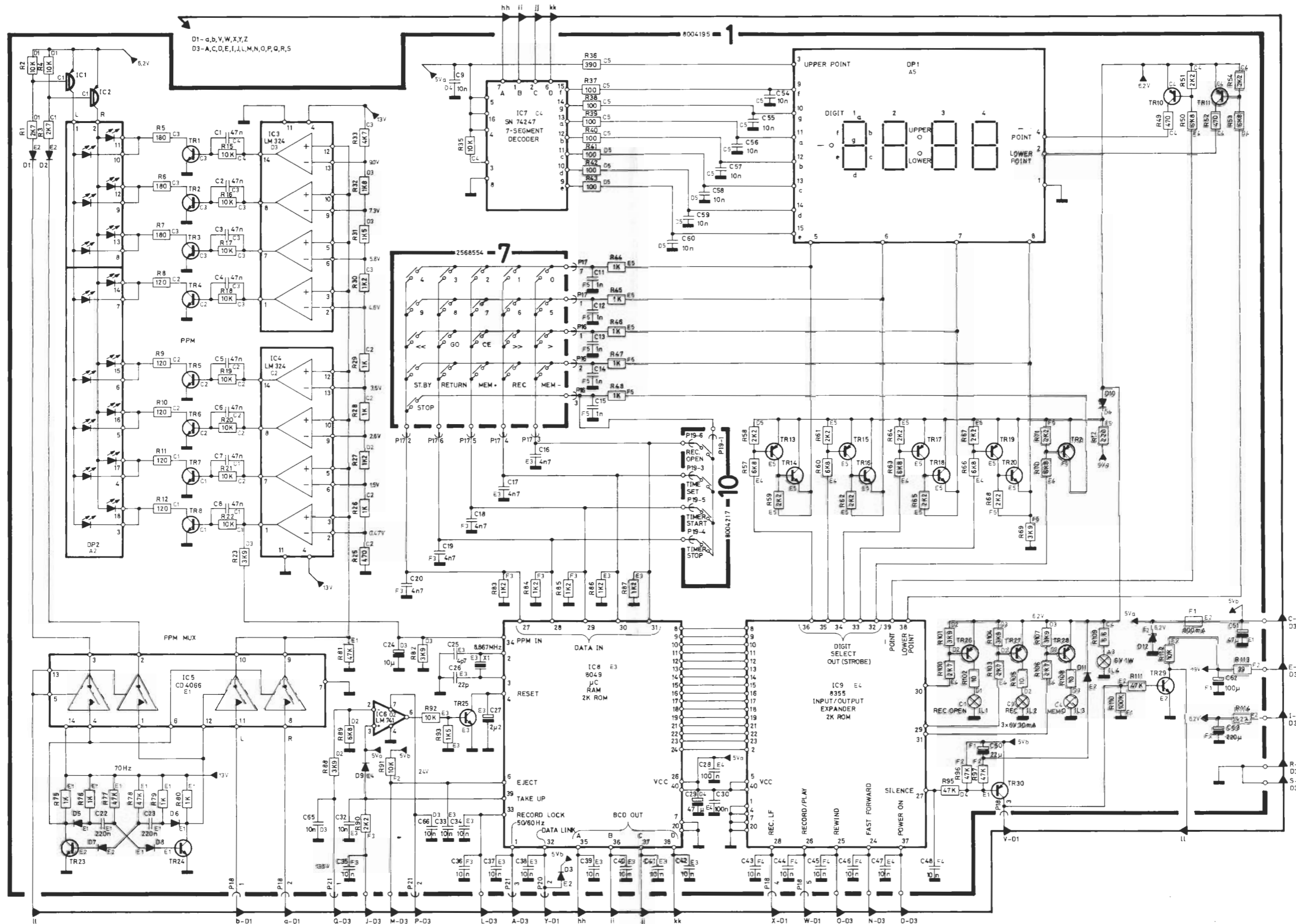

PC 3

In the first produced tape recorders the bias amplifier circuit (3TR109-209) and the MP flip-flop (3IC4) have been constructed on two small intermediate prints. The prints are shown on the below diagrams. From production No. 2381002 the two circuits mentioned have been incorporated in PC3.

The two intermediate prints are available complete as Nos:
 3TR109 - 209 8004282
 3IC4 8004283

PC 3

I de først producerede apparater er bias amplifier kredsløbet (3TR109-209), samt MP flip-floppen (3IC4) opbygget på to små mellemprent. Printene er vist på nedenstående skitser. Fra apparat nr. 2381002 er de nævnte kredsløb indført på PC3. Mellemprentene kan leveres monteret under nr.:
 3TR109 - 209 8004282
 3IC4 8004283

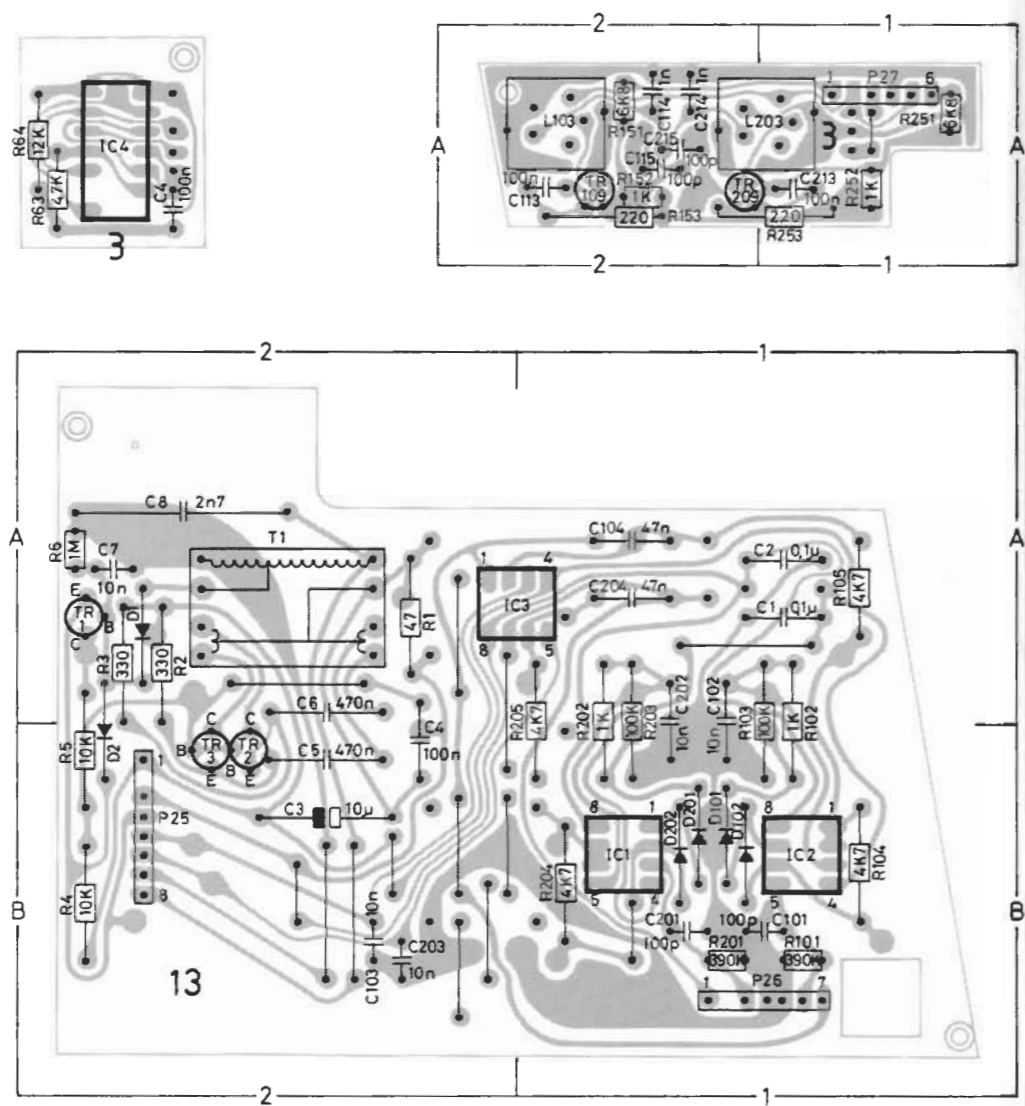

DIAGRAM 1 FOR BEOCORD 8002

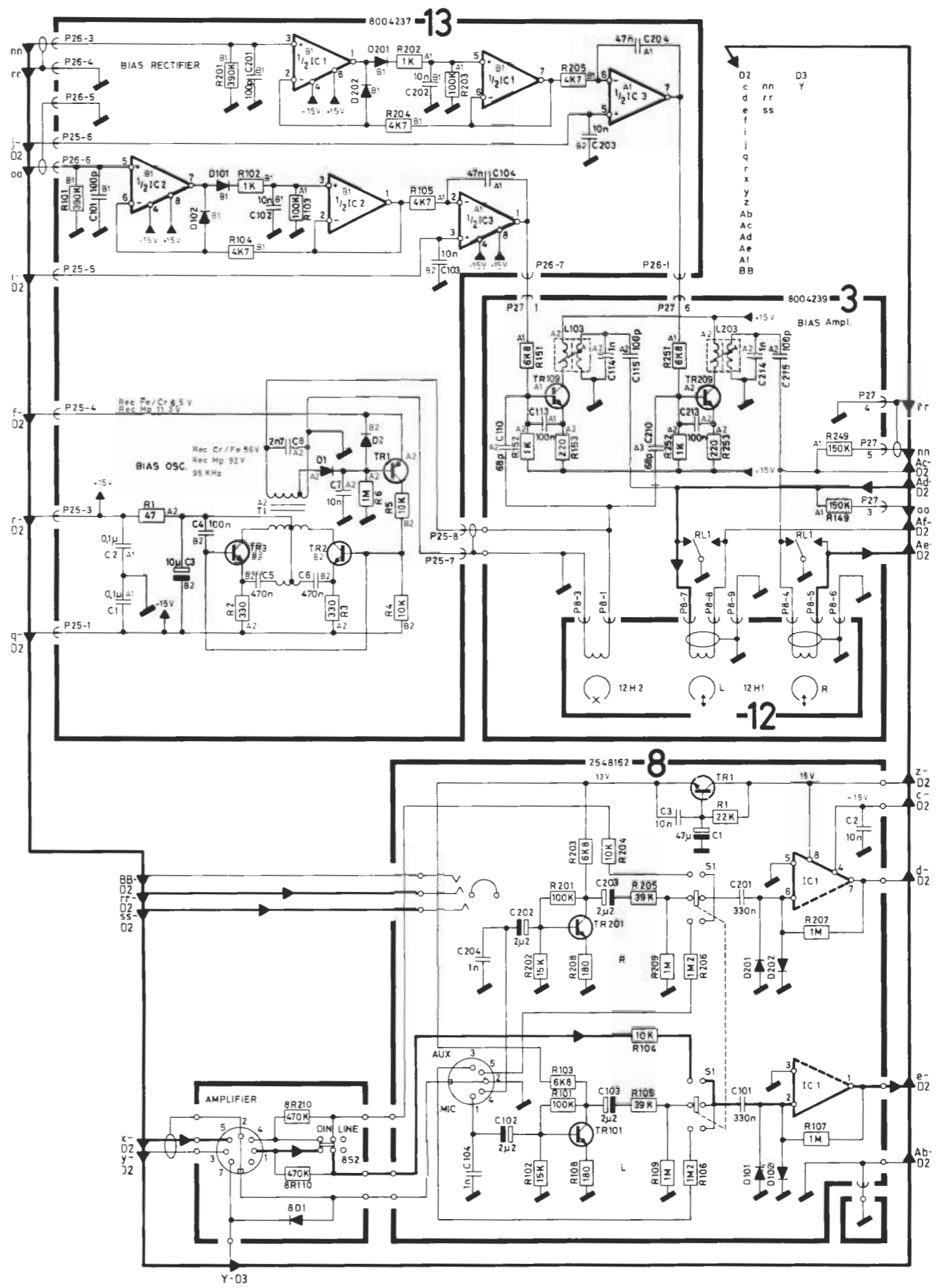
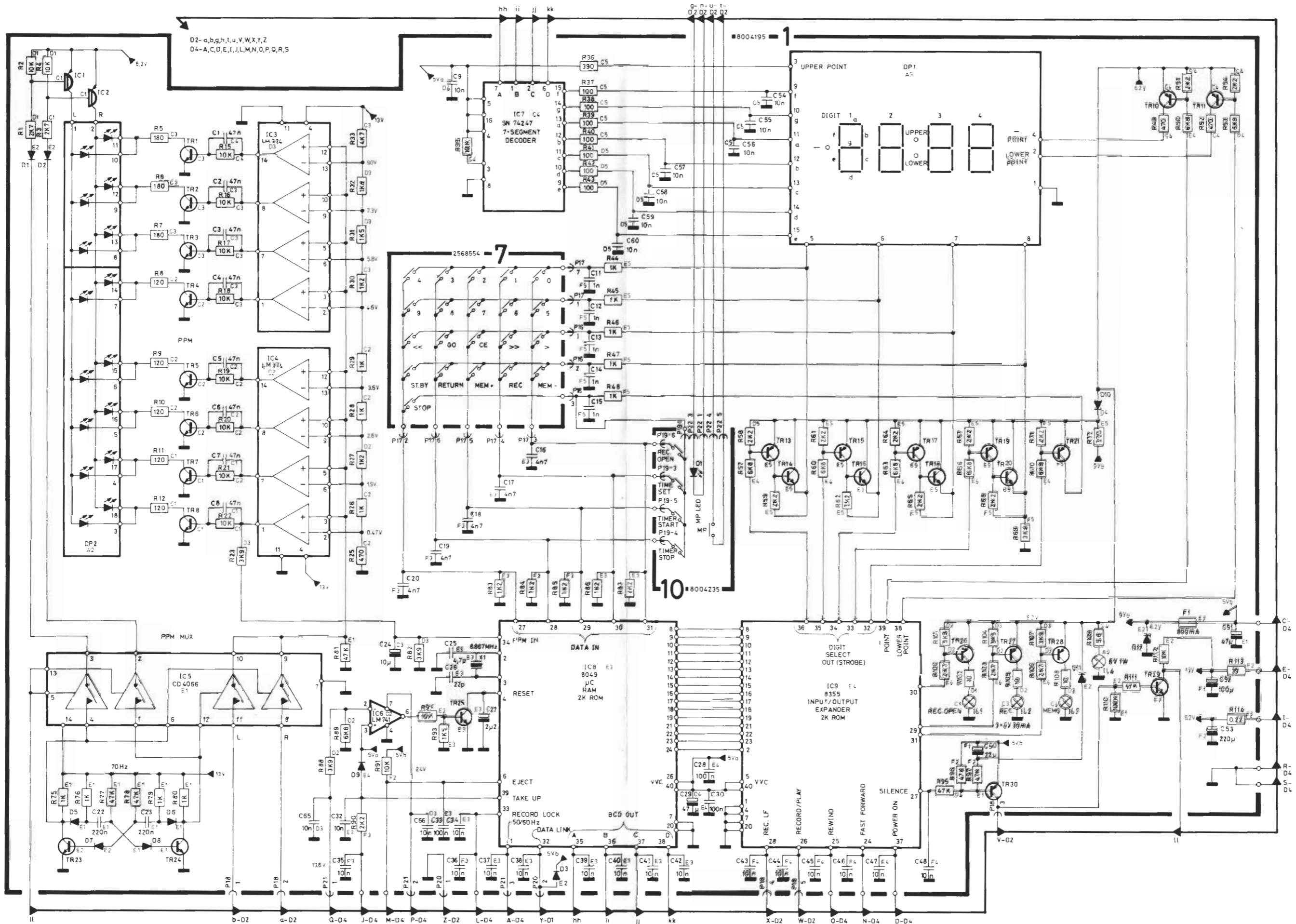

DIAGRAM 3 FOR BECORD 8002



BEOCORD 6000 LIST OF TRANSISTORS

19	20	24	31	32			
1TR1	8320097 20	BC 547B		2TR103/203	8320097 20	BC 547B	
1TR2							
1TR3				3TR1	8320152 20	BC 557B	
1TR4							
1TR5				3TR2	8320331 20	BC 328-25/18	
1TR6							
1TR7				3TR3	8320097 20	BC 547B	
1TR8							
1TR10	8320152 20	BC 557B		3TR4	8320152 20	BC 557B	
1TR11				3TR5			
1TR13				3TR6	8320097 20	BC 547B	
1TR14	8320329 20	BC 338-25/18		3TR7	8320237 20	BC 546B	
				3TR8			
1TR15	8320152 20	BC 557B		3TR9	8320152 20	BC 557B	
1TR16	8320329 20	BC 338-25/18		3TR10	8320097 20	BC 547B	
				3TR11			
1TR17	8320152 20	BC 557B		3TR12	8320152 20	BC 557B	
1TR18	8320329 20	BC 338-25/18		3TR13	8320097 20	BC 547B	
				3TR14			
1TR19	8320152 20	BC 557B		3TR15	8320152 20	BC 557B	
1TR20	8320329 20	BC 338-25/18		3TR101/201*	8320344 20	BC 550B	
				3TR102/202*	8320069 20	BC 559B	
1TR21	8320152 20	BC 557B		3TR103/203	8320097 20	BC 547B	
1TR23	8320097 20	BC 547B		3TR104/204	8320152 20	BC 557B	
1TR24				3TR105/205	8320366 19	NPS A16	
1TR25				3TR106/206			
1TR26	8320152 20	BC 557B		3TR107/207	8320097 20	BC 547B	
1TR27				4TR1	8320428 32	BD 438	
1TR28				4TR2	8320097 20	BC 547B	
1TR29	8320097 20	BC 547B		4TR3	8320321 19	MPS A06	
1TR30	8320152 20	BC 557B		4TR4	8320152 20	BC 557B	
2TR1	8320152 20	BC 557B		4TR5	8320427 32	BD 437	
2TR101/201	8320097 20	BC 547B					
2TR102/202*	8320396 24	2N 5639					
		24 MPF 4392					

LIST OF IC's

4TR6	8320152 20	BC 557B	4TR13	8320441 32	BD 439
4TR7	8320097 20	BC 547B	4TR14		
4TR8	8320152 20	BC 557B	4TR15	8320331 20	BC 328-25/18
4TR9	8320097 20	BC 547B	4TR16	8320457 20	MTJ 619
4TR11	8320321 19	MPS A06	5TR1	8320369 31	BP534
4TR12	8320331 20	BC 328-25/18	8TR1	8320097 20	BC 547B
			8TR101/201*	8320344 20	BC 550B

- * Speciel udvalgt eller bearbejdet eksemplar.
- * Specially selected or adapted sample.
- * Speziell ausgewähltes und bearbeitets exemplar.

19	32	101	102	103	105	123	124
1IC1	8340025 19	MPSA 65	**2IC101/201	8340295 101	LM 1111BN		
1IC2	19	SPS 5431					
1IC3	8340157 102	LM 324N	3IC1	8340048 103	MC 1458CP1		
1IC4	102	TDB 0124DP	4IC1	8340207 32	BD 678		
	102	MLM 324P	5IC1	8340208 105	μA 78M15uC		
1IC5	8340209 102	CD 4016		105	MC 78 M 15		
		BCN			CT		
		102	HEF 4016BP		105	μA 78 M 15	
		102	MC4016BLP			CKC	
1IC6	8340141 103	LM 741CN	5IC2	8340240 123	μA 7915 uC		
	103	μA 741CP		123	LM 3207-15		
	103	μA 741CN			123	MC 7915 CT	
	103	SFC 741DC	5IC3	8340212 105	MC 78 M 5		
1IC7	8340156 101	SN 74247N			CT		
					105	μA 78 M 5	
1IC8	8340158 124	μP 8049			CKC		
					105	μA 78 M 5	
1IC9	8340159 124	EXP 8355			uC		
2IC1	8340294 103	LF 353N	8IC1	8340294 103	LF 353 N		
2IC2							
2IC3	8340232 102	LM 378	12IC14	8004216	Hall-element		
2IC4	8340294 103	LF 353N					

** See section 11

LIST OF DIODES

209	215	217	218				

1D1	8300058	217	SFD 184	4D1	8300218	209	ZPD 13V5%
1D2		215	1N 4148			209	BZX 79C
1D3		209	1N 4148				13V0
1D5						209	BZX 83C
1D6							13V0
1D7							
1D8				4D2	8300023	209	1N 4002/RL
1D9				4D3			
1D10	8300189	218	BAV 19	4D4	8300058	217	SFD 184
		218	BA 219/TB			215	1N 4148
						209	1N 4148
1D11	8300058	217	SFD 184	4D5	8300135	209	ZPD 3.3V5%
		215	1N 4148			209	BZX 79C3V3
		209	1N 4148			209	BZX 83C3V3
1D12	8300201	209	ZPD 6.2V5%	4D6	8300058	217	SFD 184
		209	BZX 79C6V2			215	1N 4148
		209	BZX 83C6V2			209	1N 4148
1DP1	8330011		FCS 8499	4D8	8300023	209	1N 4002/RL
1DP2	8330003		FNA 0098	4D9			
2D1	8300058	217	SFD 184	4D10			
2D2		215	1N 4148	4D11			
2D3		209	1N 4148	4D12	8300058	217	SFD 184
2D4						215	1N 4148
2D102/202						209	1N 4148
2D103/203				4D14	8300023	209	1N 4002/RL
3D1	8300058	217	SFD 184	4D15	8300058	217	SFD 184
3D2		215	1N 4148	4D16		215	1N 4148
3D3		209	1N 4148			209	1N 4148
3D4	8300189	218	BAV 19	6D1	8300023	209	1N 4002/RL
		218	BA 219/TB	6D2			
3D5	8300058	217	SFD 184	6D3			
3D6		215	1N 4148	6D4			
3D7		209	1N 4148	6D5			
3D8				6D6			
3D9				6D7			
				6D8			
3D11	8300036	209	ZPD 4.7V5%	6D9	8300294	209	MR 501 RL
		209	BZX 79C4V7	6D10		209	1N 5401
		209	BZX 83C4V7	6D11		209	1N 5401 RL
3D12	8300058	217	SFD 184	6D12			
3D13		215	1N 4148				
3D14		209	1N 4148				

BEOCORD 8002
LIST OF TRANSISTORS

6D13	8300036	209	ZPD 4.7V5%	8D1	8300058	217	SFD 184
		209	BZX 79C4V7	8D101/201		215	1N 4148
		209	BZX 83C4V7	8D102/202		209	1N 4148

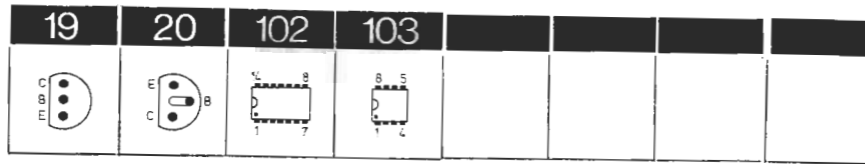

2TR104/204	8320097	20	BC547B	3TR106/206	8320097	20	BC 547B
3TR7	8320152	20	BC 557B	3TR107/207	8320366	19	NPS A 16
3TR8	8320097	20	BC 547B	3TR108/208			
3TR14	8320152	20	BC 557B	3TR109/209	8320237	20	BC 546B
3TR16	8320097	20	BC 547B	13TR1	8320152	20	BC 557B
3TR17	8320152	20	BC 557B	13TR2	8320237	20	BC 546B
				13TR3			

LIST OF IC's

3IC1	8340195	103	LF 353 N	3IC4	8340176	102	CD4013BCN
		103	TL 072 CP			102	MC4013BCP
		103	μAF 772 TC			102	HEF 4013BP
3IC2	8340202	102	HEF 4066BP	13IC1	8340294	103	LF 353N
		102	CD4066BCN	13IC2			
3IC3	8340195	103	LF 353 N	13IC3	8340048	103	MC 1458CP1
		103	TL 072 CP				
		103	μAF 772TC				

LIST OF DIODES

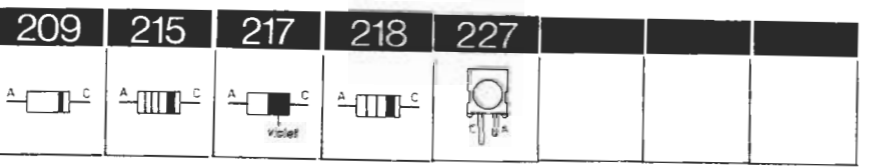

3D3	8300189	218	BAV 19	3D8	8300058	217	SFD 184
		218	BA 219/TB	3D9		215	1N 4148
3D4	8300058	217	SFD 184	3D10		209	1N 4148
3D5		215	1N 4148	3D11			
3D6		209	1N 4148	3D12			
3D7	8300173	209	ZPD 8.2V5%	3D13			
		209	BZX 79C	3D14			
		8V2		10D1	8330038	227	MW 57124
		209	BZX 83C	13D1	8300058	217	SFD 184
		8V2		13D2		215	1N 4148
				13D101/201		209	1N 4148
				13D102/202			

LIST OF ELECTRICAL PARTS
Beocord 6000
Microcomputer and display,
8004195, PC1

R1	5010298	2.7 kohms ±5% 1/8W	R59	5010064	2.2 kohms ±5% 1/8W
R2	5010059	10 kohms ±5% 1/8W	R60	5010052	6.8 kohms ±5% 1/8W
R3	5010298	2.7 kohms ±5% 1/8W	R61	5010064	2.2 kohms ±5% 1/8W
R4	5010059	10 kohms ±5% 1/8W	R62	5010064	2.2 kohms ±5% 1/8W
R5	5010362	180 ohms ±5% 1/8W	R63	5010052	6.8 kohms ±5% 1/8W
R6	5010362	180 ohms ±5% 1/8W	R64	5010064	2.2 kohms ±5% 1/8W
R7	5010362	180 ohms ±5% 1/8W	R65	5010064	2.2 kohms ±5% 1/8W
R8	5010128	120 ohms ±5% 1/8W	R66	5010052	6.8 kohms ±5% 1/8W
R9	5010128	120 ohms ±5% 1/8W	R67	5010064	2.2 kohms ±5% 1/8W
R10	5010128	120 ohms ±5% 1/8W	R68	5010064	2.2 kohms ±5% 1/8W
R11	5010128	120 ohms ±5% 1/8W	R69	5010069	3.9 kohms ±5% 1/8W
R12	5010128	120 ohms ±5% 1/8W	R70	5010052	6.8 kohms ±5% 1/8W
R15	5010059	10 kohms ±5% 1/8W	R71	5010064	2.2 kohms ±5% 1/8W
R16	5010059	10 kohms ±5% 1/8W	R72	5010092	220 ohms ±5% 1/8W
R17	5010059	10 kohms ±5% 1/8W	R75	5010040	1 kohms ±5% 1/8W
R18	5010059	10 kohms ±5% 1/8W	R76	5010040	1 kohms ±5% 1/8W
R19	5010059	10 kohms ±5% 1/8W	R77	5010045	47 kohms ±5% 1/8W
R20	5010059	10 kohms ±5% 1/8W	R78	5010045	47 kohms ±5% 1/8W
R21	5010059	10 kohms ±5% 1/8W	R79	5010040	1 kohms ±5% 1/8W
R22	5010059	10 kohms ±5% 1/8W	R80	5010040	1 kohms ±5% 1/8W
R23	5010069	3.9 kohms ±5% 1/8W	R81	5010045	47 kohms ±5% 1/8W
R25	5010058	470 ohms ±5% 1/8W	R82	5010069	3.9 kohms ±5% 1/8W
R26	5010040	1 kohms ±5% 1/8W	R83	5010153	1.2 kohms ±5% 1/8W
R27	5010153	1.2 kohms ±5% 1/8W	R84	5010153	1.2 kohms ±5% 1/8W
R28	5010040	1 kohms ±5% 1/8W	R85	5010153	1.2 kohms ±5% 1/8W
R29	5010040	1 kohms ±5% 1/8W	R86	5010153	1.2 kohms ±5% 1/8W
R30	5010153	1.2 kohms ±5% 1/8W	R87	5010153	1.2 kohms ±5% 1/8W
R31	5010247	1.5 kohms ±5% 1/8W	R88	5010069	3.9 kohms ±5% 1/8W
R32	5010066	1.8 kohms ±5% 1/8W	R89	5010052	6.8 kohms ±5% 1/8W
R33	5010048	4.7 kohms ±5% 1/8W	R90	5010064	2.2 kohms ±5% 1/8W
R35	5010059	10 kohms ±5% 1/8W	R91	5010059	10 kohms ±5% 1/8W
R36	5010070	390 ohms ±5% 1/8W	R92	5010059	10 kohms ±5% 1/8W
R37	5010065	100 ohms ±5% 1/8W	R93	5010247	1.5 kohms ±5% 1/8W
R38	5010065	100 ohms ±5% 1/8W	R95	5010045	47 kohms ±5% 1/8W
R39	5010065	100 ohms ±5% 1/8W	R96	5010045	47 kohms ±5% 1/8W
R40	5010065	100 ohms ±5% 1/8W	R97	5010045	47 kohms ±5% 1/8W
R41	5010065	100 ohms ±5% 1/8W	R100	5010298	2.7 kohms ±5% 1/8W
R42	5010065	100 ohms ±5% 1/8W	R101	5010069	3.9 kohms ±5% 1/8W
R43	5010065	100 ohms ±5% 1/8W	R102	5010506	10 ohms ±5% 1/8W
R44	5010040	1 kohms ±5% 1/8W	R103	5010298	2.7 kohms ±5% 1/8W
R45	5010040	1 kohms ±5% 1/8W	R104	5010069	3.9 kohms ±5% 1/8W
R46	5010040	1 kohms ±5% 1/8W	R105	5010506	10 ohms ±5% 1/8W
R47	5010040	1 kohms ±5% 1/8W	R106	5010298	2.7 kohms ±5% 1/8W
R48	5010040	1 kohms ±5% 1/8W	R107	5010069	3.9 kohms ±5% 1/8W
R49	5010058	470 ohms ±5% 1/8W	R108	5010506	10 ohms ±5% 1/8W
R50	5010052	6.8 kohms ±5% 1/8W	R109	5001155	5.6 ohms ±10% 1/2W
R51	5010064	2.2 kohms ±5% 1/8W	R110	5010049	100 kohms ±5% 1/8W
R52	5010058	470 ohms ±5% 1/8W	R111	5010045	47 kohms ±5% 1/8W
R53	5010052	6.8 kohms ±5% 1/8W	R112	5010059	10 kohms ±5% 1/8W
R54	5010064	2.2 kohms ±5% 1/8W	R113	5010782	39 ohms ±5% 1/4W
R57	5010052	6.8 kohms ±5% 1/8W	R114	5102016	0.22 ohms ±10% 1W
R58	5010064	2.2 kohms ±5% 1/8W			

C1	4030015	47 nF -20+80% 16V	C26	4030059	22 pF ±5% 250V
C2	4030015	47 nF -20+80% 16V	C27	4201069	2.2 μF ±20% 35V
C3	4030015	47 nF -20+80% 16V	C28	4030010	100 nF -20+100% 16V
C4	4030015	47 nF -20+80% 16V	C29	4200092	47 μF 16V
C5	4030015	47 nF -20+80% 16V	C30	4030010	100 nF -20+100% 16V
C6	4030015	47 nF -20+80% 16V	C32	4010041	10 nF -20+80% 40V
C7	4030015	47 nF -20+80% 16V	C33	4130179	100 nF ±20% 63V
C8	4030015	47 nF -20+80% 16V	C34	4040041	10 nF -20+80% 40V
C9	4010041	10 nF -20+80% 40V	C35	4010041	10 nF -20+80% 40V
C11	4010027	1 nF ±10% 100V	C36	4010041	10 nF -20+80% 40V
C12	4010027	1 nF ±10% 100V	C37	4010041	10 nF -20+80% 40V
C13	4010027	1 nF ±10% 100V	C38	4010041	10 nF -20+80% 40V
C14	4010027	1 nF ±10% 100V	C39	4010041	10 nF -20+80% 40V
C15	4010027	1 nF ±10% 100V	C40	4010041	10 nF -20+80% 40V
C16	4010063	4.7 nF ±10% 63V	C41	4010041	10 nF -20+80% 40V
C17	4010063	4.7 nF ±10% 63V	C42	4010041	10 nF -20+80% 40V
C18	4010063	4.7 nF ±10% 63V	C43	4010041	10 nF -20+80% 40V
C19	4010063	4.7 nF ±10% 63V	C44	4010041	10 nF -20+80% 40V
C20	4010063	4.7 nF ±10% 63V	C45	4010041	10 nF -20+80% 40V
C22	4130104	220 nF ±20% 100V	C46	4010041	10 nF -20+80% 40V
C23	4130104	220 nF ±20% 100V	C47	4010041	10 nF -20+80% 40V
C24	4200167	10 μF ±20% 16V	C48	4010041	10 nF -20+80% 40V
C25	4000020	47 pF ±0.25 pF 63V	C50	4200100	22 μF 40V

C51	4200092	47 μ F 16V	C57	4010041	10 nF -20+80% 40V
C52	4200099	100 μ F 16V	C58	4010041	10 nF -20+80% 40V
C53	4200118	220 μ F 10V	C59	4010041	10 nF -20+80% 40V
C54	4010041	10 nF -20+80% 40V	C60	4010041	10 nF -20+80% 40V
C55	4010041	10 nF -20+80% 40V	C65	4010041	10 nF -20+80% 40V
C56	4010041	10 nF -20+80% 40V	C66	4010041	10 nF -20+80% 40V

IL1	8230057	6V 30mA	IL3	8230057	6V 30mA
IL2	8230057	6V 30mA	IL4	8230062	6V 1W

X1 8090005 8.8672 MHz

F1 6604004 800mA-F/250V S IEC 127 7500002 Holder for F1

P16	7200055	Socket for μ C	P17	7210232	Socket 7 pins
	3302312	Screen for μ C	P18	7210216	Socket 5 pins
	7210229	Socket 3 pins	P20/P21	7220167	Plug 6 pins

R2	5010049	100 kohms \pm 5% 1/8W	R213	5010247	1.5 kohms \pm 5% 1/8W
R3	5010362	180 ohms \pm 5% 1/8W	R214	5010059	10 kohms \pm 5% 1/8W
R4	5010848	3.3 Mohms \pm 10% 1/8W	R215	5370074	10 kohms LIN
R7	5010073	390 kohms \pm 5% 1/8W	R216	5010079	22 kohms \pm 5% 1/8W
R8	5010079	22 kohms \pm 5% 1/8W	R217	5020145	8.66 kohms \pm 1% 1/8W
R9	5010059	10 kohms \pm 5% 1/8W	R218	5010053	15 kohms \pm 5% 1/8W
R12	5010742	47 ohms \pm 5% 1/8W	R219	5010638	10 Mohms \pm 10% 1/8W
R13	5010141	27 kohms \pm 5% 1/8W	R221	5010048	4.7 kohms \pm 5% 1/8W
R14	5010062	68 kohms \pm 5% 1/8W	R222	5010064	2.2 kohms \pm 5% 1/8W
R15	5310091	2 x 22 kohms Log	R223	5010056	82 ohms \pm 5% 1/8W
R201	5010069	3.9 kohms \pm 5% 1/8W	R224	5010053	15 kohms \pm 5% 1/8W
R202	5010059	10 kohms \pm 5% 1/8W	R225	5010045	47 kohms \pm 5% 1/8W
R203	5310105	22 kohms Log paired	R230	5010041	5.6 kohms \pm 5% 1/8W
R204	5010265	3.3 kohms \pm 2% 1/4W	R231	5010069	3.9 kohms \pm 5% 1/8W
R206	5010045	47 kohms \pm 5% 1/8W	R233	5010065	100 ohms \pm 5% 1/8W
R207	5010063	150 kohms \pm 5% 1/8W	R234	5010298	2.7 kohms \pm 5% 1/8W
R208	5010117	330 kohms \pm 5% 1/8W	R235	5010506	10 ohms \pm 5% 1/8W
R209	5010083	270 kohms \pm 5% 1/8W	R236	5001008	47 ohms \pm 10% 1/2W
R210	5010059	10 kohms \pm 5% 1/8W	R237	5010066	1.8 kohms \pm 5% 1/8W
R211	5010040	1 kohms \pm 5% 1/8W	R238	5010046	12 kohms \pm 5% 1/8W

C2	4201065	10 μ F 63V	C210	4130087	47 nF \pm 10% 250V
C3	4130107	0.1 μ F \pm 10% 250V	C212	4200342	10 μ F -10+50% 63V
C4	4200100	22 μ F 40V	C213	4130150	100 nF \pm 20% 100V
C8	4130107	0.1 μ F \pm 10% 250V	C214	4130106	330 nF \pm 20% 100V
C9	4130107	0.1 μ F \pm 10% 250V	C216	4130114	470 nF \pm 10% 100V
C10	4130107	0.1 μ F \pm 10% 250V	C217	4130166	27 nF \pm 5% 250V
C201	4130136	1 μ F \pm 20% 100V	C218	4130142	220 nF \pm 5% 100V
C202	4200099	100 μ F 16V	C219	4200342	10 μ F -10+50% 63V
C203	4010027	1 nF \pm 10% 100V	C220	4200342	10 μ F -10+50% 63V
C204	4010027	1 nF \pm 10% 100V	C221	4200342	10 μ F -10+50% 63V
C206	4130194	33 nF \pm 5% 250V	C223	4010041	10 nF -20+80% 40V
C207	4010027	1 nF \pm 10% 100V	C225	4010062	330 pF \pm 10% 100V
C208	4100031	4.7 nF \pm 1% 63V	C226	4000023	150 pF \pm 5% 63V
C209	4200342	10 μ F -10+50% 63V			

L200 8022104 10.6 μ H 3304017 Screen for L201
L201 8022059 2.8 mH

P10 7220166 Plug 3 pins
P18 7220202 Plug 5 pins

RL1 7600065 Relay 6V

S1 7400200 2 pol. 3358150 Heat sink
S2 7400201 4 pol.

Play back, Bias, 8004261, PC3

R1	5010742	47 ohms \pm 5% 1/8W	R45	5010791	1.8 Mohms \pm 10% 1/8W
R2	5010742	47 ohms \pm 5% 1/8W	R46	5010093	1.5 Mohms \pm 10% 1/8W
R3	5010041	5.6 kohms \pm 5% 1/8W	R47	5010245	2.2 Mohms \pm 10% 1/8W
R4	5010069	3.9 kohms \pm 5% 1/8W	R48	5010041	5.6 kohms \pm 5% 1/8W
R5	5010059	10 kohms \pm 5% 1/8W	R49	5010128	120 ohms \pm 5% 1/8W
R6	5010059	10 kohms \pm 5% 1/8W	R50	5010083	270 kohms \pm 5% 1/8W
R7	5010059	10 kohms \pm 5% 1/8W	R51	5010079	22 kohms \pm 5% 1/8W
R8	5010298	2.7 kohms \pm 5% 1/8W	R52	5010049	100 kohms \pm 5% 1/8W
R9	5010044	330 ohms \pm 5% 1/8W	R201	5010151	56 ohms \pm 5% 1/8W
R10	5010059	10 kohms \pm 5% 1/8W	R202	5010052	6.8 kohms \pm 5% 1/8W
R11	5010045	47 kohms \pm 5% 1/8W	R203	5010040	1 kohms \pm 5% 1/8W
R12	5010060	39 kohms \pm 5% 1/8W	R204	5010056	82 ohms \pm 5% 1/8W
R13	5010049	100 kohms \pm 5% 1/8W	R205	5010151	56 ohms \pm 5% 1/8W
R20	5010742	47 ohms \pm 5% 1/8W	R206	5010062	68 kohms \pm 5% 1/8W
R21	5011019	330 ohms \pm 5% 1/4W	R207	5010048	4.7 kohms \pm 5% 1/8W
R22	5010049	100 kohms \pm 5% 1/8W	R208	5010063	150 kohms \pm 5% 1/8W
R23	5010054	1 Mohms \pm 5% 1/8W	R209	5010733	5.1 kohms \pm 5% 1/8W
R24	5010075	33 kohms \pm 5% 1/8W	R210	5010076	3.3 kohms \pm 5% 1/8W
R25	5010059	10 kohms \pm 5% 1/8W	R211	5010064	2.2 kohms \pm 5% 1/8W
R26	5010059	10 kohms \pm 5% 1/8W	R212	5010069	3.9 kohms \pm 5% 1/8W
R27	5010040	1 kohms \pm 5% 1/8W	R213	5010041	5.6 kohms \pm 5% 1/8W
R28	5011019	330 ohms \pm 5% 1/4W	R214	5010064	2.2 kohms \pm 5% 1/8W
R29	5010054	1 Mohms \pm 5% 1/8W	R215	5370061	50 kohms LIN
R30	5010059	10 kohms \pm 5% 1/8W	R216	5010054	1 Mohms \pm 5% 1/8W
R31	5010059	10 kohms \pm 5% 1/8W	R220	5010135	18 kohms \pm 5% 1/8W
R32	5370074	10 kohms LIN	R221	5370068	25 kohms LIN
R33	5010041	5.6 kohms \pm 5% 1/8W	R222	5010048	4.7 kohms \pm 5% 1/8W
R34	5370061	50 kohms LIN	R224	5010052	6.8 kohms \pm 5% 1/8W
R35	5010135	18 kohms \pm 5% 1/8W	R225	5010053	15 kohms \pm 5% 1/8W
R36	5370074	10 kohms LIN	R226	5010046	12 kohms \pm 5% 1/8W
R37	5010041	5.6 kohms \pm 5% 1/8W	R227	5370061	50 kohms LIN
R38	5010062	68 kohms \pm 5% 1/8W	R228	5010059	10 kohms \pm 5% 1/8W
R39	5010079	22 kohms \pm 5% 1/8W	R229	5010059	10 kohms \pm 5% 1/8W
R41	5010054	1 Mohms \pm 5% 1/8W	R230	5010040	1 kohms \pm 5% 1/8W
R42	5010047	120 kohms \pm 5% 1/8W	R231	5010069	3.9 kohms \pm 5% 1/8W
R43	5010053	15 kohms \pm 5% 1/8W	R240	5010048	4.7 kohms \pm 5% 1/8W
R44	5010045	47 kohms \pm 5% 1/8W			

C1	4200099	100 μ F 16V	C202	4130107	100 nF \pm 10% 250V
C2	4200099	100 μ F 16V	C203	4200109	470 μ F 6V
C3	4130107	100 nF \pm 10% 250V	C204	4130195	22 nF \pm 5% 250V
C4	4130114	470 nF \pm 10% 100V	C205	4201035	2.2 μ F -10+50% 63V
C5	4130114	470 nF \pm 10% 100V	C206	4130109	10 nF \pm 10% 250V
C6	4100141	2.7 nF \pm 5% 630V	C207	4010027	1 nF \pm 10% 100V
C7	4010041	10 nF -20+80% 40V	C210	4010081	270 pF \pm 10% 100V
C8	4200342	10 μ F -10+50% 63V	C211	4340003	5.5-6.5 pF
C9	4130155	1 μ F \pm 10% 100V	C230	4130109	10 nF \pm 10% 250V
C201	4010062	330 pF \pm 10% 100V			

L201 8022101 10 mH

P8 7220124 Plug 9/8 pins P12 7220128 Plug 6/5 pins
P9 7210227 Socket 7 pins P13 7210227 Socket 7 pins
P11 7220122 Plug 4/3 pins P14 7210226 Socket 6 pins

RL1 7600062 Relay 6V

T1 8020388 Osc.

3304017 Screen for L201

Power Supply, 8004194, PC4

R1	5010041	5.6 kohms $\pm 5\%$ 1/8W	R27	5010247	1.5 kohms $\pm 5\%$ 1/8W
R2	5010059	10 kohms $\pm 5\%$ 1/8W	R28	5010298	2.7 kohms $\pm 5\%$ 1/8W
R4	5010059	10 kohms $\pm 5\%$ 1/8W	R29	5010049	100 kohms $\pm 5\%$ 1/8W
R5	5010048	4.7 kohms $\pm 5\%$ 1/8W	R30	5010059	10 kohms $\pm 5\%$ 1/8W
R7	5010059	10 kohms $\pm 5\%$ 1/8W	R31	5001035	2.7 kohms $\pm 10\%$ 1/2W
R8	5001027	820 ohms $\pm 10\%$ 1/2W	R32	5010053	15 kohms $\pm 5\%$ 1/8W
R10	5010059	10 kohms $\pm 5\%$ 1/8W	R33	5010048	4.7 kohms $\pm 5\%$ 1/8W
R11	5010046	12 kohms $\pm 5\%$ 1/8W	R34	5001011	82 ohms $\pm 10\%$ 1/2W
R12	5010059	10 kohms $\pm 5\%$ 1/8W	R35	5010040	1 kohms $\pm 5\%$ 1/8W
R13	5010053	15 kohms $\pm 5\%$ 1/8W	R42	5010053	15 kohms $\pm 5\%$ 1/8W
R14	5010067	560 ohms $\pm 5\%$ 1/8W	R43	5010061	56 kohms $\pm 5\%$ 1/8W
R16	5001010	68 ohms $\pm 10\%$ 1/2W	R45	5010040	1 kohms $\pm 5\%$ 1/8W
R17	5010144	680 ohms $\pm 5\%$ 1/8W	R46	5001011	82 ohms $\pm 10\%$ 1/2W
R18	5010065	100 ohms $\pm 5\%$ 1/8W	R47	5010053	15 kohms $\pm 5\%$ 1/8W
R19	5010000	270 ohms $\pm 5\%$ 1/8W	R48	5010048	4.7 kohms $\pm 5\%$ 1/8W
R20	5010058	470 ohms $\pm 5\%$ 1/8W	R49	5010000	270 ohms $\pm 5\%$ 1/8W
R21	5370059	220 ohms $\pm 20\%$ 0.1W LIN.	R51	5010040	1 kohms $\pm 5\%$ 1/8W
R22	5010044	330 ohms $\pm 5\%$ 1/8W	R52	5010040	1 kohms $\pm 5\%$ 1/8W
R26	5010154	8.2 kohms $\pm 5\%$ 1/8W			

C1	4010060	22 nF -20+80% 40V	C6	4130089	22 nF $\pm 10\%$ 250V
C4	4200342	10 μ F -10+50% 63V	C8	4200092	47 μ F 16C

F1	6600000	250 mA-T/250V S IEC 127	7200038	Holder for Fuse
----	---------	-------------------------	---------	-----------------

P1	7220183	Plug 17/16 pins	P5	7210256	Socket 8/7 pins
P2	7210231	Socket 6 pins	P6	7210232	Socket 7 pins
P3	7210232	Socket 7 pins	P7	7210234	Socket 6/5 pins
P4	7210230	Socket 4 pins			

2819154 Ground spring

Power Unit, 3358132, PC5

R1	5001164	3.3 ohms $\pm 10\%$ 1/2W			
C1	4130150	100 nF $\pm 20\%$ 100V	C4	4130179	100 nF $\pm 20\%$ 63V
C2	4130150	100 nF $\pm 20\%$ 100V	C5	4010060	22 nF -20+80% 40V
C3	4130171	330 nF $\pm 20\%$ 63V			

Rectifier, 8004192, PC6

R1	5010247	1.5 kohms $\pm 5\%$ 1/8W	R2	5010059	10 kohms $\pm 5\%$ 1/8W
C1	4200388	1000 μ F 35V	C5	4130107	100 nF $\pm 10\%$ 250V
C2	4200388	1000 μ F 35V	C6	4130107	100 nF $\pm 10\%$ 250V
C3	4200410	5000 μ F -10+15%	C7	4130107	100 nF $\pm 10\%$ 250V
C4	4130114	470 nF $\pm 10\%$ 100V	C8	4130107	100 nF $\pm 10\%$ 250V

Mic and Input Amplifier
2548162, PC8

R1	5010079	22 kohms $\pm 5\%$ 1/8W	R206	5010665	1.2 Mohms $\pm 5\%$ 1/8W
R201	5010049	100 kohms $\pm 5\%$ 1/8W	R207	5010054	1 Mohms $\pm 5\%$ 1/8W
R202	5010053	15 kohms $\pm 5\%$ 1/8W	R208	5010362	180 ohms $\pm 5\%$ 1/8W
R203	5010052	6.8 kohms $\pm 5\%$ 1/8W	R209	5010054	1 Mohms $\pm 5\%$ 1/8W
R204	5010059	10 kohms $\pm 5\%$ 1/8W	R210	5010078	470 kohms $\pm 5\%$ 1/8W
R205	5010060	39 kohms $\pm 5\%$ 1/8W			

C1	4200092	47 μ F 16V	C3	4010041	10 nF -20+80% 40V
C2	4010041	10 nF -20+80% 40V			

C201	4130171	330 nF $\pm 20\%$ 63V	C203	4200423	2.2 μ F $\pm 20\%$ 50V
C202	4200423	2.2 μ F $\pm 20\%$ 50V	C204	4010027	1 nF $\pm 10\%$ 100V

S1	7400199		S2	7400200	DIN LINE
----	---------	--	----	---------	----------

7500075 Ground spring

Transformer, 8013210

09F1	6600042	630 mA, type 4831, 4833, 4841, 4843	6600041	315 mA, type 4834, 4835, 4836, 4844, 4845, 4846
	6600033	500 mA, type 4832, 4842	6600026	700 mA, type 4837, 4847

Beocord 8002
Rec. Dolby NR 8004233, PC2

R2	5010049	100 kohms $\pm 5\%$ 1/8W	R216	5010059	10 kohms $\pm 5\%$ 1/8W
R3	5010362	180 ohms $\pm 5\%$ 1/8W	R217	5020145	8.66 kohms $\pm 1\%$ 1/8W
R4	5010848	3.3 Mohms $\pm 5\%$ 1/8W	R218	5010053	15 kohms $\pm 5\%$ 1/8W
R7	5010073	390 kohms $\pm 5\%$ 1/8W	R219	5010638	10 Mohms $\pm 10\%$ 1/8W
R8	5010079	22 kohms $\pm 5\%$ 1/8W	R221	5010048	4.7 kohms $\pm 5\%$ 1/8W
R9	5010059	10 kohms $\pm 5\%$ 1/8W	R222	5010066	1.8 kohms $\pm 5\%$ 1/8W
R12	5010742	47 ohms $\pm 5\%$ 1/8W	R223	5010411	47 ohms $\pm 5\%$ 1/8W
R13	5010141	27 kohms $\pm 5\%$ 1/8W	R224	5010053	15 kohms $\pm 5\%$ 1/8W
R14	5010062	68 kohms $\pm 5\%$ 1/8W	R225	5010045	47 kohms $\pm 5\%$ 1/8W
R15	5310091	2 x 22 kohms Log	R226	5010064	2.2 kohms $\pm 5\%$ 1/8W
R201	5010069	3.9 kohms $\pm 5\%$ 1/8W	R229	5010061	56 kohms $\pm 5\%$ 1/8W
R202	5010059	10 kohms $\pm 5\%$ 1/8W	R230	5010041	5.6 kohms $\pm 5\%$ 1/8W
R203	5310105	22 kohms Log paired	R231	5010069	3.9 kohms $\pm 5\%$ 1/8W
R204	5010265	3.3 kohms $\pm 2\%$ 1/4W	R233	5010065	100 ohms $\pm 5\%$ 1/8W
R206	5010045	47 kohms $\pm 5\%$ 1/8W	R234	5010298	2.7 kohms $\pm 5\%$ 1/8W
R207	5010063	150 kohms $\pm 5\%$ 1/8W	R235	5010506	10 ohms $\pm 5\%$ 1/8W
R208	5010117	330 kohms $\pm 5\%$ 1/8W	R236	5001008	47 ohms $\pm 10\%$ 1/2W
R209	5010083	270 kohms $\pm 5\%$ 1/8W	R238	5010066	1.8 kohms $\pm 5\%$ 1/8W
R210	5010059	10 kohms $\pm 5\%$ 1/8W	R239	5010053	15 kohms $\pm 5\%$ 1/8W
R213	5010247	1.5 kohms $\pm 5\%$ 1/8W	R240	5010049	100 kohms $\pm 5\%$ 1/8W
R214	5010059	10 kohms $\pm 5\%$ 1/8W	R241	5010061	56 kohms $\pm 5\%$ 1/8W
R215	5370074	10 kohms LIN			

C2	4201065	10 μ F 63V	C213	4130107	100 nF $\pm 10\%$ 250V
C3	4130107	0.1 μ F $\pm 10\%$ 250V	C214	4130106	330 nF $\pm 20\%$ 100V
C4	4200100	22 μ F 40V	C215	4130050	6.8 nF $\pm 10\%$ 250V
C8	4130107	0.1 μ F $\pm 10\%$ 250V	C216	4130114	0.47 μ F $\pm 10\%$ 100V
C9	4130107	0.1 μ F $\pm 10\%$ 250V	C217	4130195	22 nF $\pm 5\%$ 250V
C10	4130107	0.1 μ F $\pm 10\%$ 250V	C218	4130142	220 nF $\pm 5\%$ 100V
C201	4200423	2.2 μ F $\pm 20\%$ 50V	C219	4200342	10 μ F -10+50% 63V
C202	4200099	100 μ F 16V	C220	4200342	10 μ F -10+50% 63V
C203	4010027	1 nF $\pm 10\%$ 100V	C221	4200342	10 μ F -10+50% 63V
C204	4010027	1 nF $\pm 10\%$ 100V	C223	4010041	10 nF -20+80% 40V
C206	4130194	33 nF $\pm 5\%$ 250V	C225	4010062	330 pF $\pm 10\%$ 100V
C207	4010027	1 nF $\pm 10\%$ 100V	C226	4000023	150 pF $\pm 5\%$ 63V
C208	4100031	4.7 nF $\pm 1\%$ 63V	C227	4000071	270 pF $\pm 5\%$ 63V
C209	4200342	10 μ F -10+50% 63V	C228	4010061	2.2 nF $\pm 10\%$ 63V
C210	4130087	47 nF $\pm 10\%$ 250V	C229	4010062	330 pF $\pm 10\%$ 100V
C212	4200342	10 μ F -10+50% 63V	C230	4010063	4.7 nF $\pm 10\%$ 63V

L201	8022059	2.8 mH	3304017	Screen for L201
L202	8022111	10 mH		

P10	7220166	Plug 3 pins
P18	7220202	Plug 5 pins

RL1	7600065	Relay 6V
-----	---------	----------

S1	7400200	2 pol
----	---------	-------

3358150 Heat sink

Play back, 8004239, PC3

R1	5010742	47 ohms ±5% 1/8W
R2	5010742	47 ohms ±5% 1/8W
R3	5010041	5.6 kohms ±5% 1/8W
R4	5010069	3.9 kohms ±5% 1/8W
R5	5010045	47 kohms ±5% 1/8W
R6	5010044	330 ohms ±5% 1/8W
R7	5010059	10 kohms ±5% 1/8W
R8	5010059	10 kohms ±5% 1/8W
R9	5010298	2.7 kohms ±5% 1/8W
R10	5010059	10 kohms ±5% 1/8W
R11	5010059	10 kohms ±5% 1/8W
R12	5010049	100 kohms ±5% 1/8W
R13	5010073	390 kohms ±5% 1/8W
R14	5010059	10 kohms ±5% 1/8W
R15	5010049	100 kohms ±5% 1/8W
R16	5010059	10 kohms ±5% 1/8W
R17	5010040	1 kohms ±5% 1/8W
R18	5010062	68 kohms ±5% 1/8W
R20	5010045	47 kohms ±5% 1/8W
R21	5010046	12 kohms ±5% 1/8W
R22	5010049	100 kohms ±5% 1/8W
R23	5010079	22 kohms ±5% 1/8W
R24	5010075	33 kohms ±5% 1/8W
R25	5010075	33 kohms ±5% 1/8W
R26	5010054	1 Mohms ±5% 1/8W
R27	5010049	100 kohms ±5% 1/8W
R28	5010064	2.2 kohms ±5% 1/8W
R30	5010054	1 Mohms ±5% 1/8W
R31	5010047	120 kohms ±5% 1/8W
R32	5010053	15 kohms ±5% 1/8W
R33	5010073	390 kohms ±5% 1/8W
R34	5010141	27 kohms ±5% 1/8W
R35	5010120	220 kohms ±5% 1/8W
R36	5010069	3.9 kohms ±5% 1/8W
R37	5010154	8.2 kohms ±5% 1/8W
R38	5370074	10 kohms LIN (Fe bias)
R39	5010046	12 kohms ±5% 1/8W
R40	5370068	25 kohms LIN (Mp bias)
R41	5010049	100 kohms ±5% 1/8W
R42	5010049	100 kohms ±5% 1/8W
R43	5010079	22 kohms ±5% 1/8W
R44	5010049	100 kohms ±5% 1/8W
R45	5010049	100 kohms ±5% 1/8W
R46	5010060	39 kohms ±5% 1/8W
R47	5010049	100 kohms ±5% 1/8W
R49	5010245	2.2 Mohms ±10% 1/8W
R50	5010054	1 Mohms ±5% 1/8W
R51	5010141	27 kohms ±5% 1/8W
R52	5010075	33 kohms ±5% 1/8W
R53	5010049	100 kohms ±5% 1/8W

C1	4200099	100 μF 16V
C2	4200099	100 μF 16V
C3	4200423	2.2 μF ±20% 50V
C4	4130179	100 nF ±20% 63V
C201	4010027	1 nF ±10% 100V
C202	4010062	330 pF ±10% 100V
C203	4130107	100 nF ±10% 250V
C204	4200109	470 μF 6V
C205	4130195	22 nF ±5% 250V

L201	8022104	10.6 μH
L202	8022111	10 mH

P8	7220124	Plug 9/8 pins
P9	7210227	Socket 7 pins
P11	7220122	Plug 4/3 pins
P12	7220128	Plug 6/5 pins

RL1	7600052	Relay 6V
-----	---------	----------

S1	7400233	
----	---------	--

Bang & Olufsen

R54	5010049	100 kohms ±5% 1/8W
R55	5010045	47 kohms ±5% 1/8W
R56	5010045	47 kohms ±5% 1/8W
R47	5010062	68 kohms ±5% 1/8W
R58	5010045	47 kohms ±5% 1/8W
R59	5010120	220 kohms ±5% 1/8W
R60	5010091	82 kohms ±5% 1/8W
R61	5010059	10 kohms ±5% 1/8W
R62	5010045	47 kohms ±5% 1/8W
R63	5010045	47 kohms ±5% 1/8W
R64	5010046	12 kohms ±5% 1/8W
R201	5010054	1 Mohms ±5% 1/8W
R202	5010151	56 ohms ±5% 1/8W
R203	5010056	82 ohms ±5% 1/8W
R204	5010151	56 ohms ±5% 1/8W
R205	5010040	1 kohms ±5% 1/8W
R206	5010052	6.8 kohms ±5% 1/8W
R207	5010048	4.7 kohms ±5% 1/8W
R208	5010063	150 kohms ±5% 1/8W
R209	5010733	5.1 kohms ±5% 1/8W
R210	5010062	68 kohms ±5% 1/8W
R212	5010076	3.3 kohms ±5% 1/8W
R213	5010064	2.2 kohms ±5% 1/8W
R214	5010069	3.9 kohms ±5% 1/8W
R215	5010041	5.6 kohms ±5% 1/8W
R216	5370061	50 kohms LIN (play level)
R217	5010064	2.2 kohms ±5% 1/8W
R220	5010076	3.3 kohms ±5% 1/8W
R221	5010041	5.6 kohms ±5% 1/8W
R222	5010076	3.3 kohms ±5% 1/8W
R223	5010041	5.6 kohms ±5% 1/8W
R224	5370061	50 kohms ±5% 1/8W
R230	5010053	15 kohms ±5% 1/8W
R231	5370068	25 kohms LIN Rec-current
R232	5010048	4.7 kohms ±5% 1/8W
R233	5010052	6.8 kohms ±5% 1/8W
R234	5010048	4.7 kohms ±5% 1/8W
R235	5010046	12 kohms ±5% 1/8W
R236	5010053	15 kohms ±5% 1/8W
R237	5010053	15 kohms ±5% 1/8W
R240	5010046	12 kohms ±5% 1/8W
R241	5370061	50 kohms LIN output level
R242	5010059	10 kohms ±5% 1/8W
R243	5010069	3.9 kohms ±5% 1/8W
R244	5010059	10 kohms ±5% 1/8W
R245	5010040	1 kohms ±5% 1/8W
R249	5010063	150 kohms ±5% 1/8W
R251	5010052	6.8 kohms ±5% 1/8W
R252	5010040	1 kohms ±5% 1/8W
R253	5010092	220 ohms ±5% 1/8W

C206	4201035	2.2 μF -10+50% 63V
C207	4130109	10 nF ±10% 250V
C210	4000132	68 pF ±5% 250V
C211	4101031	270 pF ±5% 63V
C212	4130195	22 nF ±5% 250V
C213	4130179	100 nF ±20% 63V
C214	4101019	1 nF ±5% 63V
C215	4101002	100 pF ±5% 63V

L203	8022123	Bias
	3304017	Screen for L203

P13	7210227	Socket 7 pins
P14	7210226	Socket 6 pins
P27	7220128	Plug 6/5 pins

Bang & Olufsen

Bias Osc. 8004237, PC13

R1	5010742	47 ohms ±5% 1/8W
R2	5011019	330 ohms ±5% 1/4W
R3	5011019	330 ohms ±5% 1/4W
R4	5010059	10 kohms ±5% 1/8W
R5	5010059	10 kohms ±5% 1/8W
R6	5010054	1 Mohms ±5% 1/8W

C1	4130150	0.1 μF ±20% 100V
C2	4130150	0.1 μF ±20% 100V
C3	4200342	10 μF -10+50% 63V
C4	4130150	100 nF ±20% 100V
C5	4130114	470 nF ±10% 100V
C6	4130114	470 nF ±10% 100V

P25	7220130	Plug 8/7 pins
P26	7220115	Plug 7/6 pins

T1	8020338	
----	---------	--

Other parts as Beocord 6000

R201	5010073	390 kohms ±5% 1/8W
R202	5010040	1 kohms ±5% 1/8W
R203	5010049	100 kohms ±5% 1/8W
R204	5010048	4.7 kohms ±5% 1/8W
R205	5010048	kohms ±5% 1/8W

C7	4010072	10 nF -20+100% 40V
C8	4100141	2.7 nF ±5% 630V
C201	4101002	100 pF ±5% 63V
C202	4130081	10 nF ±20% 250V
C203	4010072	10 nF -20+100% 40V
C204	4130087	47 nF ±10% 250V

LIST OF MECHANICAL PARTS
Beocord 6000

004	2560094	Profile	0027	2391052	Lock
005	3164359	Lid	0028	2034046	Screw AM2 x 8
006	2015090	Screw 3.5 x 6.5 black	0029	2015090	Screw 3.5 x 6.5 black
007	2015090	Screw 3.5 x 6.5 black	0030	2819146	Spring
008	2530361	Bracket	0031	2530361	Bracket
009	3110031	Cabinet, teak	0032	2775726	Button
	3110033	Cabinet, rosewood	0033	2812084	Spring
	3110034	Cabinet, oak	0034	2013094	Screw 2.9 x 6.5 black
	3110035	Cabinet, white	0035	2572024	Rail
0010	2390020	Plastic washer	0036	3164362	Lid
0011	2622015	Washer	0037	2013094	Screw 2.9 x 6.5 black
0012	6273864	Chassis lead	0038	2905080	Hinge
0013	2039905	Screw AM3 x 12	0039	3164360	Panel
0014	3150045	Clamp	0040	3164403	Cover, complete
0015	3322057	Window	0041	2775710	Button
0016	3132050	Housing	0042	3170178	Foil
0017	3199057	Dial	0043	3162129	Lid
0020	2570063	Arm	0044	2380122	Nut M4
0021	3130061	Damping system	0045	2390020	Plastic washer
0022	2013095	Screw 2.9 x 9.5 black	0046	2043017	Screw M4 x 25 black
0023	2380122	Nut M4	0047	2622015	Washer
0024	2043017	Screw M4 x 25 black	0048	2039905	Screw AM3 x 12
0025	2905080	Hinge	0049	2775709	Button
0026	2830071	Pin			

01Modul	8004195	PC, microcomputer	01P2	6200032	Interconnecting cable
0101	3950009	Rubber bushing	01P7	6200033	Interconnecting cable
0102	3152273	Holder	01P19	6275447	Lead with socket

02Modul	8004262	PC, record/dolby	02P13	6200034	Interconnecting cable
02P9	6200034	Interconnecting cable	02P14	6200035	Interconnecting cable

07Modul	3168153	Operating unit, complete	0704	7500148	Contact spring
0701	3168109	Operating panel	0705	8004227	PC, keyboard
0702	2775872	Set of buttons, small	0706	2775873	Set of buttons, big

10Modul	8004217	PC, clock set			
1001	7500148	Contact spring			

004	2560086	Profile	0042	3170193	Foil
0036	3164433	Lid		2622329	Fibre washer
0039	3164417	Panel		2039043	Screw AM3 x 4
0040	3164443	Cover, complete			

02Modul	8004233	PC, record/dolby			
---------	---------	------------------	--	--	--

07Modul	2568554	Operating unit, complete	0706	2775725	Set of buttons, big
0702	2775724	Set of buttons, small			

10Modul	8004235	PC, clock set			
---------	---------	---------------	--	--	--

Other parts as Beocord 6000.

Beocord 8002

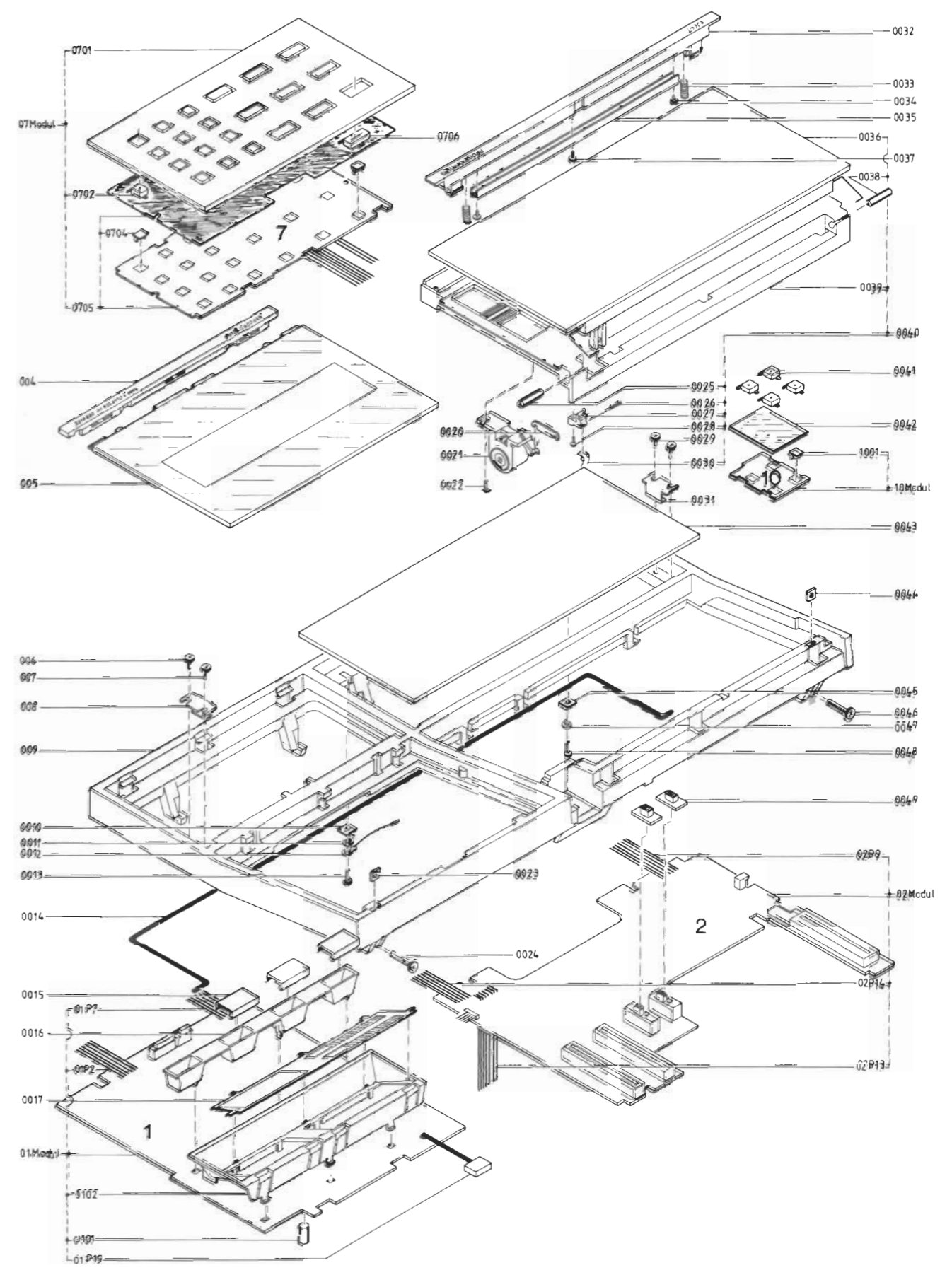

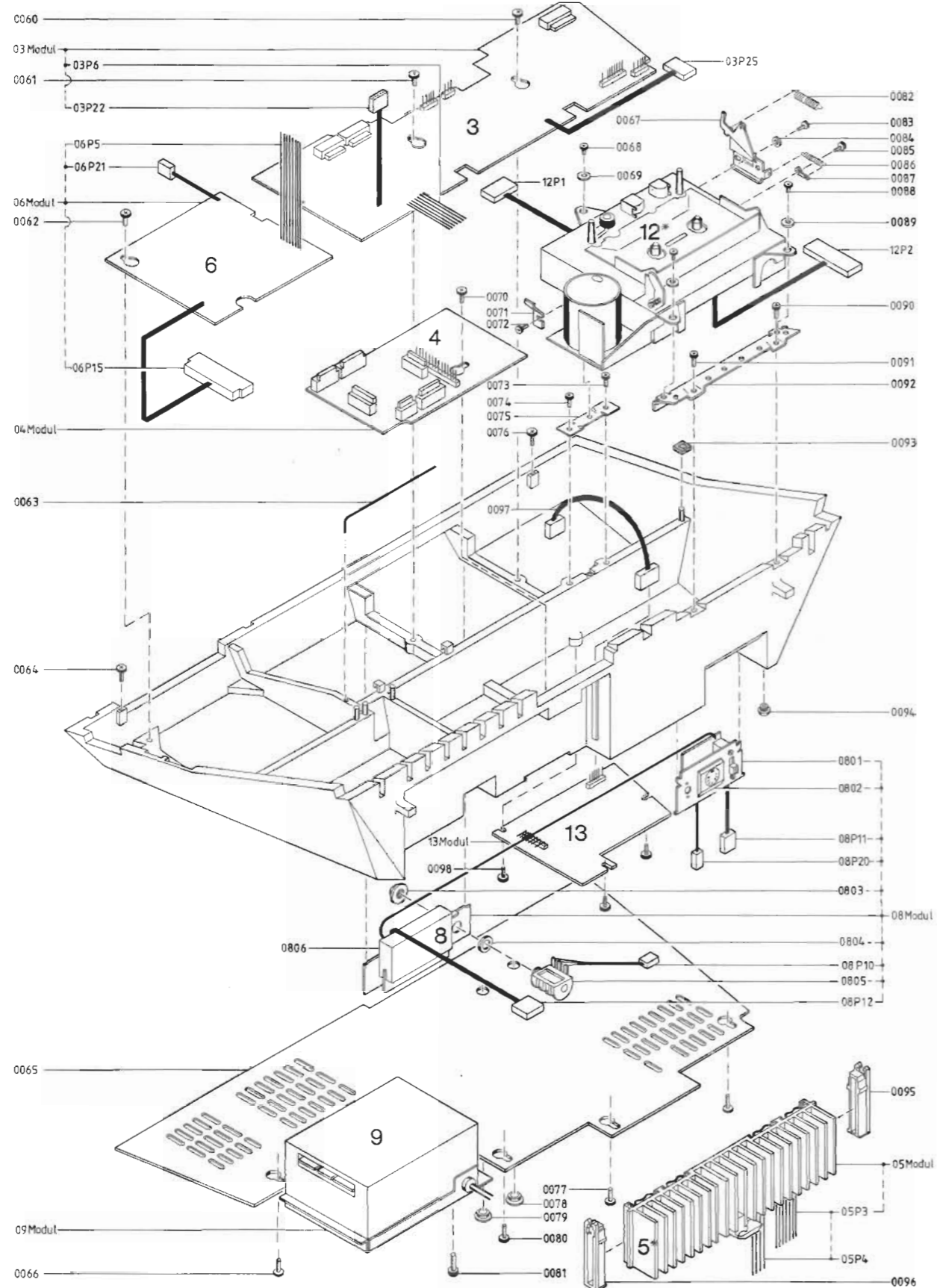

Beocord 6000

0060	2015090	Screw 3.5 x 6.5 black	0079	2938163	Bushing
0061	2015090	Screw 3.5 x 6.5 black	0080	2015091	Screw 3.5 x 9.5 black
0062	2015090	Screw 3.5 x 6.5 black	0081	2043016	Screw AM4 x 10 black
0063	2819152	Spring	0082	2810069	Spring
0064	2015090	Screw 3.5 x 6.5 black	0083	2039044	Screw M3 x 5
0065	3454250	Bottom plate	0084	2622247	Washer
0066	2015091	Screw 3.5 x 9.5 black	0085	2039044	Screw M3 x 5
0067	2854074	Arm	0086	2810069	Spring
0068	2039027	Screw AM3 x 6 black	0087	7530005	Solder tag
0069	2622247	Washer	0088	2039027	Screw AM3 x 6 black
0070	2015090	Screw 3.5 x 6.5 black	0089	2622247	Washer
0071	2548170	Bracket	0090	2015202	Screw 3.5 x 13 black
0072	2039044	Screw M3 x 5	0091	2015202	Screw 3.5 x 13 black
0073	2015202	Screw 3.5 x 13 black	0092	2530358	Bracket
0074	2015202	Screw 3.5 x 13 black	0093	3010010	Lead holder
0075	2530359	Bracket	0094	3035026	Rubber foot
0076	2015090	Screw 3.5 x 6.5 black	0095	3152271	Holder
0077	2015091	Screw 3.5 x 9.5 black	0096	3152271	Holder
0078	2938163	Bushing			

03Modul 8004261 PC, bias/replay
03P6 6273867 Interconnecting cable

04Modul 8004194 PC, power supply/control

05Modul 3358132 Heat sink complete
05P3 6273860 Set of interconnecting cables
05P4 6273860 Set of interconnecting cables

06Modul 8004192 PC, Power supply
06P5 6200031 Interconnecting cable
06P15 6275452 Lead w/socket
06P21 6275446 Lead w/socket

08Modul 2548162 Socket panel complete
0801 3122093 Bracket
0802 7210269 Socket 7-contact DIN
0803 2389045 Nut
0804 2622308 Fibre washer
0805 7210224 Jack-socket
0806 3302311 Screen
08P10 6273920 Lead w/socket
08P11 6273921 Lead w/socket
08P12 6273861 Lead w/socket
08P20 6273922 Lead w/socket

09Modul 8013211 Transformer 114V, type 4841, 4831
8013212 Transformer 120V, type 4842, 4832, USA
8013213 Transformer 127V, type 4843, 4833
8013214 Transformer 220V, type 4844, 4834
8013215 Transformer 240V, type 4845, 4835
8013216 Transformer 240V, type 4846, 4836, AUS
8013247 Transformer 105V, type 4847, 4837, JAP

12P1 6275440 Set of leads w/socket
12P2 6275441 Set of leads w/socket
3152214 Cable binder

Beocord 8002

0065 3454284 Bottom plate
0097 6273985 Lead w/socket
0098 2015090 Screw 3.5 x 6.5 black

03Modul 8004239 PC, replay
03P6 6200039 Interconnecting cable
03P22 6274014 Lead w/socket
03P25 6274015 Lead w/socket

12P1 6275477 Set of leads w/socket
12P2 6275478 Set of leads w/socket

13Modul 8004237 PC, bias

Other parts as Beocord 6000

12001	2036017	Screw M2.6 x 4	12062	2810104	Spring
12002	7530088	Solder tag	12063	2853062	Sensor
12003	2530382	Bracket	12064	2818062	Spring
12004	2036030	Screw 2.6 x 8	12065	2853061	Sensor
12005	2810110	Spring	12066	2036023	Screw 2.6 x 7
12006	2530377	Bracket	12067	2810113	Spring
12007	2036028	Screw 2.6 x 6	12068	2853068	Arm
12008	2542534	Bracket	12069	2932093	Bushing
12009	2810101	Spring	12070	2036021	Screw M2.6 x 3
12010	2917018	Ball 2.5	12071	2624045	Washer
12011	2917018	Ball 2.5	12072	2542538	Bracket
* 12012	3010017	Stop	12073	2036029	Screw 2.6 x 8
12013	2917018	Ball 2.5	12074	6140766	Mounting plate
12014	2530380	Bracket	12075	3151189	Lamp housing
12015	2036018	Screw M2.6 x 5	12076	2036022	Screw M2.6 x 5
* 12016	3010017	Stop	12077	2036022	Screw M2.6 x 5
12017	2034047	Screw M2 x 4 black	12078	2624045	Washer
12018	3151190	Holder	12079	2932089	Brass bushing
12019	3199058	Light conductor	12080	2036023	Screw M2.6 x 7
12020	3151188	Bracket	12081	2542506	Damping system
12021	3164380	Cover	12082	2036019	Screw M2.6 x 3 black
12022	2932092	Supply reel	12083	2624045	Screw
12023	2390078	E-ring 2	12084	2548172	Bracket
12024	2853063	Arm	12085	2810103	Spring
12025	2034048	Screw M2 x 5	12086	2034052	Screw M2 x 2 black
12026	2034049	Screw M2 x 4	12087	2622298	Washer
12027	2034050	Screw M2 x 7	12088	2816178	Leaf spring
12028	2034207	Screw M2 x 5	12089	2034047	Screw M2 x 4 black
12029	2622300	Washer	12091	2530379	Bracket
12030	2036029	Screw 2.6 x 8	12092	2034052	Screw M2 x 2 black
12031	2812087	Spring	12093	2810100	Spring and cord
12032	2622294	Washer	12094	2036017	Screw M2.6 x 4
12033	2812088	Spring	12095	7530088	Solder tag
12034	2036019	Screw M2.6 x 3 black	12096	2542536	Holder
12035	2816175	Leaf spring	12097	2932088	Cord pulley
12036	3151191	Wire holder	12100	2390056	E-ring 1.5
12037	2917018	Ball 2.5	12101	2722027	Pulley
12038	3112244	Chassis	12102	2072008	Threaded pin
12039	2034051	Screw 2 x 8	12103	2036021	Screw M2.6 x 3
12040	2810108	Spring	12104	2542535	Bracket
12041	2804039	Arm	12105	2036021	Screw M2.6 x 3
12042	2036028	Screw 2.6 x 6	12106	2542537	Bracket
12043	3164380	Cover	12107	2932090	Rubber bushing
12044	2932091	Take-up reel	12108	2932089	Brass bushing
12045	2036020	Screw M2.6 x 4	12109	2932090	Rubber bushing
12046	2810109	Spring	12110	2036023	Screw M2.6 x 7
12047	2390078	E-ring 2	12111	2036023	Screw M2.6 x 7
12048	2622297	Washer	12112	2530381	Bracket
12049	2804041	Thrust roller	12113	2624013	Washer
12050	2622297	Washer	12114	2039039	Screw M3 x 4
12051	2390078	E-ring 2	12115	2039039	Screw M3 x 4
12052	2853067	Arm	12116	2624013	Washer
12053	2622297	Washer	12117	2622245	Plastic washer
12054	7530089	Solder tag	12118	2034207	Screw M2 x 5
12055	2816176	Bracket	12119	2818067	Spring
12056	2036029	Screw 2.6 x 8	12120	2034051	Screw 2 x 8
12057	2816177	Leaf spring	12121	2932095	Bushing
12058	2036029	Screw 2.6 x 8	12122	2810128	Spring
12059	2917018	Ball 2.5	12123	2853090	Arm
12060	2816175	Leaf spring	12124	2013099	Screw 2.9 x 6.5
12061	2917018	Ball 2.5	12125	8004224	Noise filter
12H1	8600054	Tape head	12H2	8600055	Erase head
12IL1	8230060	Lamp			
12M1	8400101	Motor			
12S1	7410018	Switch	12S4	7410019	Switch
12TR1	8320429	Transistor			

* Replacing stops 12012/12016 new stops are to be glued with IS 12 (code no. 3980033)

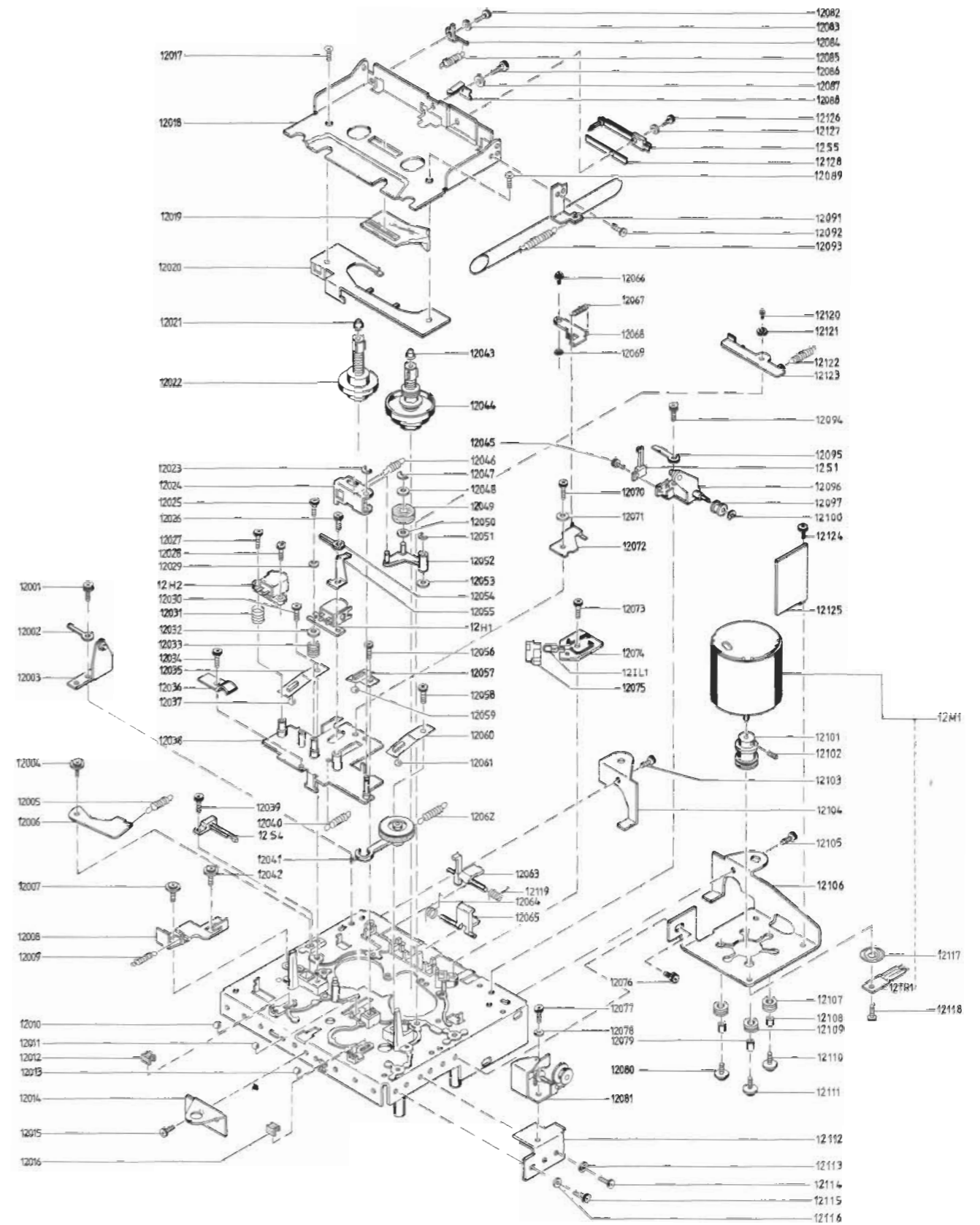

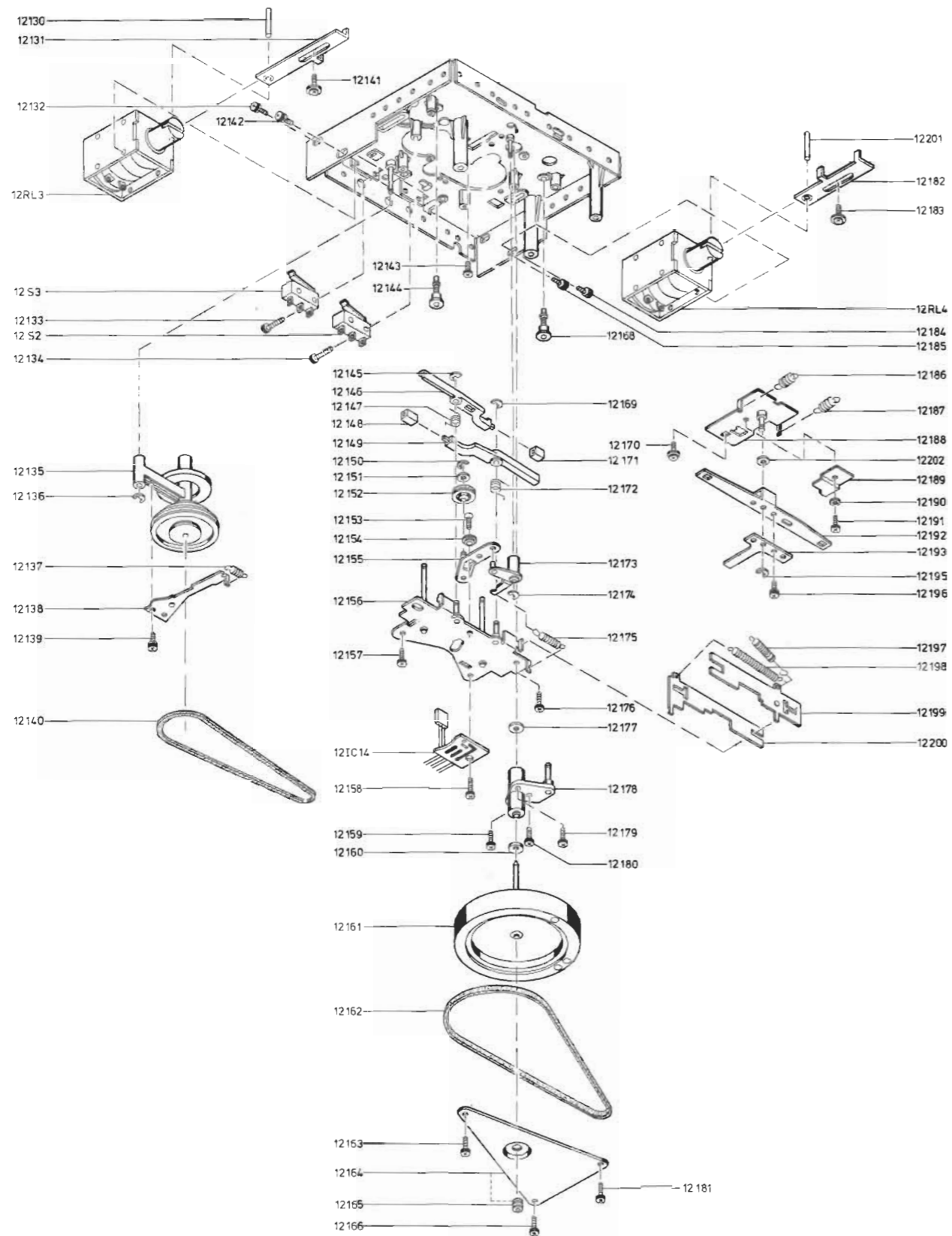

**Tape Deck
Beocord 6000**

12130	2361055	Pin	12166	2036027	Screw 2.6 x 10
12131	2894046	Arm	12168	2994023	Guide pin
12132	2038063	Screw M3 x 5	12169	2390078	E-ring 2
12133	2036026	Screw M2.3 x 10	12170	2036025	Screw M2.6 x 6.5
12134	2036026	Screw M2.3 x 10	12171	2938161	Brake block
12135	2724059	Clutch	12172	2818066	Spring
12136	2390073	E-ring 2.5	12173	2854077	Arm
12137	2810099	Spring	12174	2390078	E-ring 2
12138	2530378	Bracket	12175	2810102	Spring
12139	2036010	Screw M2.6 x 8	12176	2036027	Screw 2.6 x 10
12140	2732047	Belt	12177	2622296	Plastic washer
12141	2036030	Screw 2.6 x 8	12178	3114148	Bearing
12142	2038063	Screw M3 x 5	12179	2036024	Screw M2.6 x 6
12143	2034051	Screw 2 x 8	12180	2036024	Screw M2.6 x 6
12144	2994023	Guide pin	12181	2036027	Screw 2.6 x 10
12145	2390078	E-ring 2	12182	2894047	Arm
12146	2853065	Arm	12183	2036030	Screw 2.6 x 8
12147	2818065	Spring	12184	2038063	Screw M3 x 5
12148	2938161	Brake block	12185	2038063	Screw M3 x 5
12149	2853064	Arm	12186	2810107	Spring
12150	2390056	E-ring 1.5	12187	2810107	Spring
12151	2622299	Washer	12188	3112248	Bracket
12152	2804040	Wheel	12189	2542539	Bracket
12153	2034053	Screw M2 x 4	12190	2624045	Washer
12154	2932087	Bushing	12191	2036021	Screw M2.6 x 3
12155	2851109	Arm	12192	2853066	Arm
12156	3112246	Chassis	12193	3014049	Arm
12157	2036027	Screw 2.6 x 10	12195	2390073	E-ring 2.5
12158	2036027	Screw 2.6 x 10	12196	2036022	Screw M2.6 x 5
12159	2036024	Screw M2.6 x 6	12197	2810105	Spring
12160	2622295	Plastic washer	12198	2810106	Spring
12161	2794081	Flywheel	12199	3014050	Bracket
12162	2732048	Belt	12200	3014051	Bracket
12163	2036027	Screw 2.6 x 10	12201	2361055	Pin
12164	3112247	Holder	12202	2622322	Washer
12165	2991021	Bearing			

12IC14 8004216 PC complete

12RL3 6840254 Solenoid

12RL4 6840254 Solenoid

12S2 7410020 Switch

12S3 7410020 Switch

Beocord 8002

12018	3151206	Holder	12126	2036034	Screw 2.6 x 6 black
12088	2816186	Leaf spring	12127	2622298	Washer
12125	8004286	Noise filter	12128	3170204	Insulation

12H1 8600061 Tape head

12S5 7410025 Switch

Other parts as Beocord 6000

Heat sink 3358132

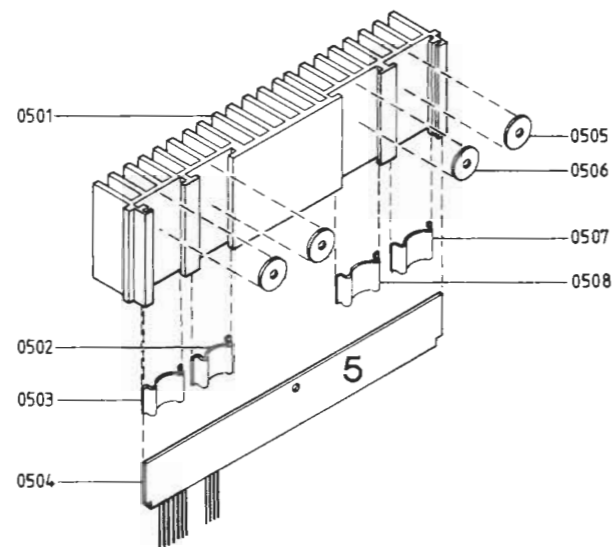

0501	3358161	Heat sink w/wire holder	0505	3170157	Mica sheet
0502	2816163	Spring	0506	3170157	Mica sheet
0503	2816163	Spring	0507	2816163	Spring
0504	8004211	PC, Heat sink	0508	2816163	Spring

Parts Not Shown

6271102	Mains lead Euro Plug	3534166	Diagram Beocord 6000
6100012	Mains lead. US	3534163	Diagram Beocord 8002
6270212	Interconnecting cable RCA/DIN	3391558	Outer carton
		3397456	Foam packing. set

Module packing

Modul nr.	Designation	Emb. nr.
01	Micro-computer	3391576
02	Record/Dolby	3391576
03	Bias/play back	3391575
*03	Play back	3391575
04	Power supply	3391574
05	Heat sink	3391574
06	Rectifier	3391574
07	Keyboard primary	sample bag
08	Input amplifier	3391574
10	Keyboard secondary	sample bag
*13	Bias	3391574

★ Is used in Beocord 8002, only.

MECHANICAL ADJUSTMENTS
Erase Head Height

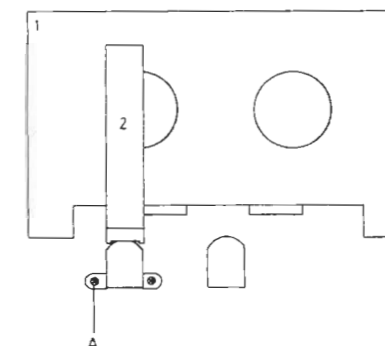

Erase head height is adjusted with adjustment tools 1 and 2 from adjustment tool kit 3624020.

Place adjustment tools in cassette holder as shown in sketch. Carefully press tape head bridge in against tool 2. With screw A adjust until tape guide goes in above tool 2.

Rewind

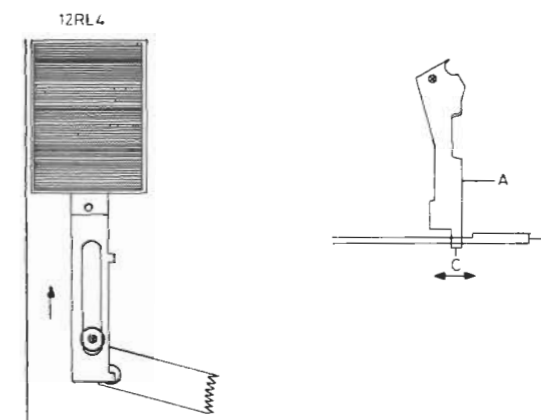

Press armature in magnet coil 12RL4 in as far as it will go. Clearance between arm A and arm B should then be 0.5 - 1 mm. Adjustment is performed by bending the arm A so that tag C moves in one of the directions of the arrow.

Thrust Roller Free Travel

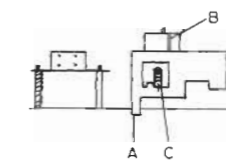

Press tape head bridge as far as it will go. Clearance between pin A on thrust roller arm and tape head bridge should then be approx. 0.5 mm. Adjustment is performed by bending pin A.

Thrust Roller Thrust

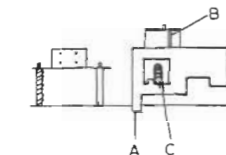

Activate play. With spring balance at point B pull thrust roller back. Carefully release thrust roller until it just touches the capstan shaft. Shift spring C to one of the two notches where the spring balance reading is closest to 300 p. Example: Spring in right-hand notch gives 280 p and spring in left-hand notch gives 330 p. Since ideal force is 300 p right-hand notch is correct adjustment.

ELECTRICAL ADJUSTMENTS
Introduction for Beocord 6000

As mentioned in the introduction the LF circuits will later on in production be changed to adjustment according to IEC standard.

Sets in which the two first digits of the serial No. is 21xxxxx are adjusted according to DIN standard. (See below instructions).

Sets in which the two first digits of the serial No. is 22xxxxx or higher are adjusted according to IEC standard. (See page 6-3).

DIN Standard

The references apply to the RH channel (the references in brackets apply to the LH channel).

Co-ordinate indication is given after the position numbers.

Make electrical adjustments without DOLBY NR.

The DIN/LINE switch must be set in position LINE.

Azimuth

Degauss tape and erase heads.

Connect AF voltmeter to 2TP3D3 (2TP6D2).

Load Azimuth tape 6780036.

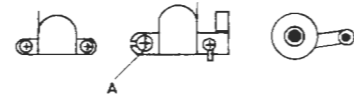

Adjust the screw A to max. in both channels and to equal output for LH and RH channels (mean value 2TP3 (2TP6)).

Speed

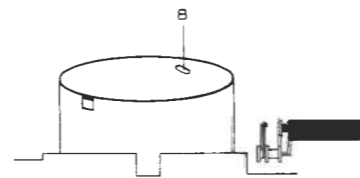

Load Wow tape 6780037.

Adjust by means of the motor potentiometer B for correct speed as read on the drift meter of a Wow meter.

Make the adjustment in a mid-tape position.

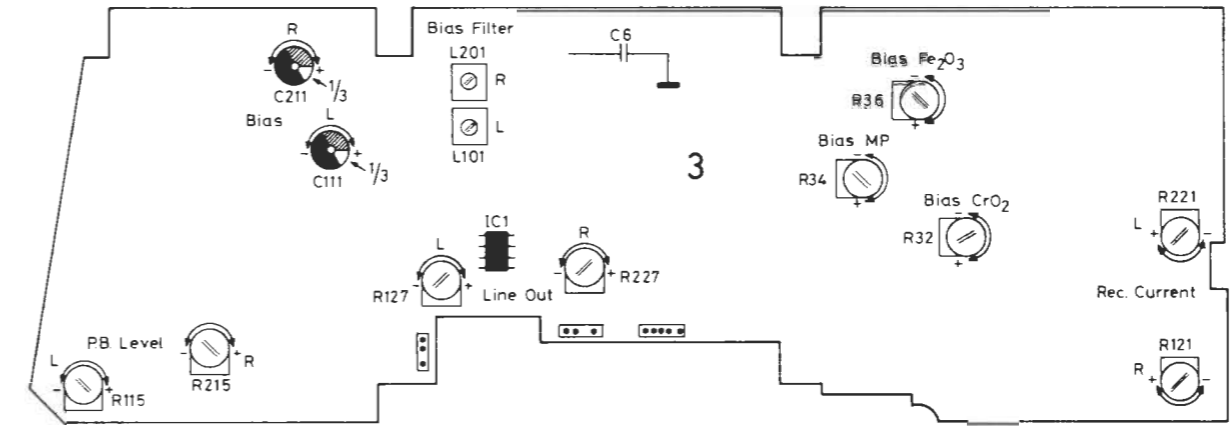
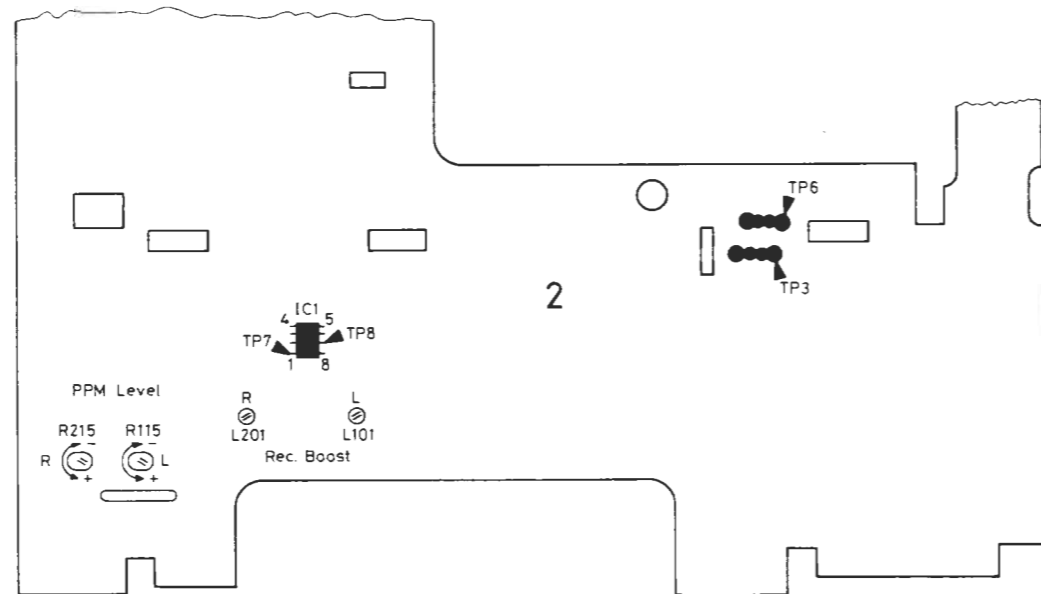

Play-back Level

Load play-back level tape 6780035.

Connect AF voltmeter to 2TP3D3 (2TP6D2).

Adjust 3R215C2 (3R115C1) until a reading of 725 mV is obtained in 2TP3 (2TP6).

Record Boost

Load CrO₂ tape.

Connect a tone generator to the AMPLIFIER input and set it to generate 333 Hz and approx. 50 mV.

Connect AF voltmeter to 2TP7D6 (2TP8D5).

Activate record pause.

Adjust the record potentiometers until a reading of 210 mV is obtained in 2TP7 (2TP8).

Change the tone generator frequency to 10 kHz.

Adjust the 2L201D6 (2L101D5) until 1 V is measured in 2TP7 (2TP8).

PPM

Set a tone generator to generate 333 Hz and approx. 1 V.

Connect AF voltmeter to 2TP3D3 (2TP6D2).

Activate record pause.

Adjust the record potentiometers until 725 mV is measured in 2TP3 (2TP6).

Adjust 2R215E7 (2R115E7) until the +2 dB LED is just glowing.

Bias Filter

Connect an AF voltmeter across the tape head.

Activate Record.

Adjust 3L201A4 (3L101B4) until max. voltage is measured across the tape head.

Bias and Record Current CrO₂
(for adjustment)

Load CrO₂ standard test tape 6780040.

Set 3R221B8 (3R121C8) in mid-position and adjust 3C211A2 (3C111B3) until 1/3 of max.

Connect an AC voltmeter across 3C6A5.

Adjust 3R32B7 until 56 V is measured across 3C6.

Record Current

Set a tone generator to generator 333 Hz and approx. 200 mV.

Connect AF voltmeter to 2TP3D3 (2TP6D2).

Activate record pause.

Adjust the record potentiometers until a reading of 200 mV is obtained in 2TP3 (2TP6).

While recording and playing back respectively, adjust 3R221B8 (3R121C8) until a reading of 200 mV is obtained in 2TP3 (2TP6) during Record as well as Play-back.

Bias

Set a tone generator to generate 333 Hz and approx. 25 mV.
Connect AF voltmeter to 2TP3D3 (2TP6D2).
Activate record pause.
Adjust the Record potentiometers until a reading of approx. 25 mV is obtained in 2TP3 (2TP6).
While recording and playing back 333 Hz and 15 kHz respectively, adjust 3C211A2 (3C111B3) until the level at 15 kHz is 1 dB higher than the level at 333 Hz. (Less bias will result in treble boost. More bias will result in treble cut).
Check Record current.

Fe₂O₃ Bias

CrO₂ bias **must** be adjusted, and tone generator and Record potentiometers must have the same settings as for CrO₂ bias.
Connect an AF voltmeter to 2TP3D3.
Load Fe₂O₃ standard test tape 6780043.
While recording and playing back 333 Hz and 15 kHz respectively, adjust 3R36A6 until the level at 15 kHz is 1 dB higher than the level at 333 Hz.

MP Bias

CrO₂ bias **must** be adjusted and tone generator and Record potentiometers must have the same setting as for CrO₂ bias.
Set the AUTO-MP switch at MP.
Connect an AF voltmeter to 2TP3D3.
Load MP standard test tape 6780059.
While recording and playing back 333 Hz and 15 kHz respectively, adjust 3R34A6 until the level at 15 kHz is 1 dB higher than the level at 333 Hz.

ELECTRICAL ADJUSTMENTS for Beocord 6000 IEC Standard

In the main, IEC Standard adjustments of Beocord 6000 correspond to the DIN Standard adjustments, and therefore only the few deviating points are mentioned in the following.

Record Boost

Load CrO₂ tape.
Connect a tone generator to the AMPLIFIER input and set it to generate 333 Hz and approx. 50 mV.
Connect an AF voltmeter to 2TP7D6 (2TP8D5).
Activate Record pause.
Adjust the Record potentiometers until a reading of 200 mV is measured in 2TP7 (2TP8).
Change the frequency of the tone generator to 15 kHz.
Adjust 2L201D6 (2L101D5) until 2 V is measured in 2TP7 (2TP8).

To adjust to CrO₂ Bias

Load CrO₂ standard test tape 6780066.
Set 3R221B8 (3R121C8) in mid-position and adjust 3C211A2 (3C111B3) until 1/3 of max.
Connect an AC voltmeter across 3C6A5.
Adjust 3R32B7 until 52 V is measured across 3C6.

Fe₂O₃ Bias

Use Fe₂O₃ standard test tape 6780067.

Bias Control

Control of the bias adjustment can be made with DM1 as described under Electrical Adjustments of Beocord 8002.

ELECTRICAL ADJUSTMENTS for Beocord 8002

Azimuth

The references apply to **RH channel** (the references in brackets apply to LH channel).
Coordinate indication is given after the position numbers.
Make electrical adjustments without **DOLBY NR**. The DIN/LINE switch must be set in position **LINE**.
The MPX switch must be set in position **OUT**.

Degauss tape and erase heads.
Connect AF voltmeter to 2TP3D3 (2TP6D2).
Load Azimuth tape 6780036.

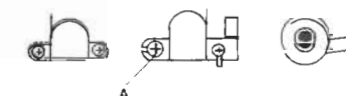

Adjust the screw A to max. in both channels and to equal output for LH and RH channels (mean value 2TP3 (2TP6)).

Speed

Load Wow tape 6780037.
Adjust by means of the motor potentiometer B for correct speed as read on the drift meter of a Wow meter.
Make the adjustment in a mid-tape position.

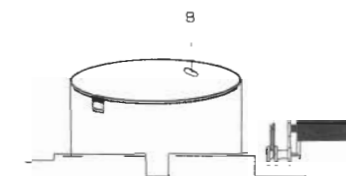

Play-back Level

Load play-back level tape 6780035.
Connect AF voltmeter to 2TP3D3 (2TP6D2).
Adjust 3R216C2 (3R116C2) until a reading of 725 mV is obtained in 2TP3 (2TP6).

Record Boost

This adjustment must be very accurate.
Load CrO₂ tape.
Connect a tone generator to the AMPLIFIER input and set it to generate 333 Hz and approx. 30 mV.
Connect AF voltmeter to 2TP7D6 (2TP8D5).
Activate record pause.
Adjust the record potentiometers until a reading of 100 mV is obtained in 2TP7 (2TP8).
Connect AF voltmeter to 2TP3D3 (2TP6D2).
Take a reading of the voltage in 2TP3 (2TP6) and write it down.
Change the tone generator frequency to 19 kHz.
Adjust the record potentiometers in such a way that the voltage in 2TP3 (2TP6) is exactly the same at 19 kHz as at 333 Hz.
Connect an AF voltmeter to 2TP7D6 (2TP8D5).
Adjust with 2L201D6 (2L101D5) until 1.4 V is measured in 2TP7 (2TP8) (corresponds to +23 dB at 19 kHz in relation to 333 Hz).

PPM

Set the tone generator to generate 333 Hz and approx. 300 mV.
Connect AF voltmeter to 2TP3D3 (2TP6D2).
Activate record pause.
Adjust the record potentiometers until 725 mV is measured in 2TP3 (2TP6).
Adjust 2R215E7 (2R115E7) until the +2 dB LED is just glowing.

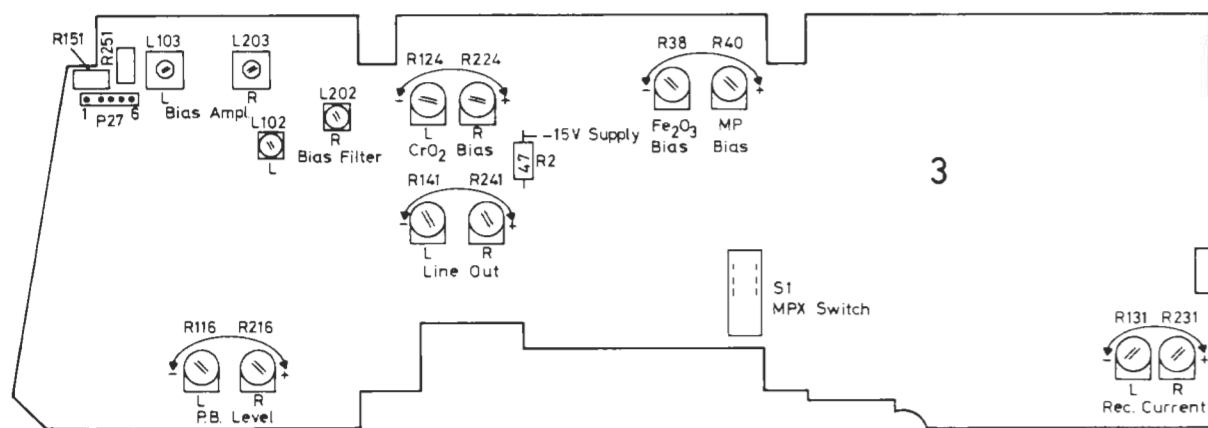
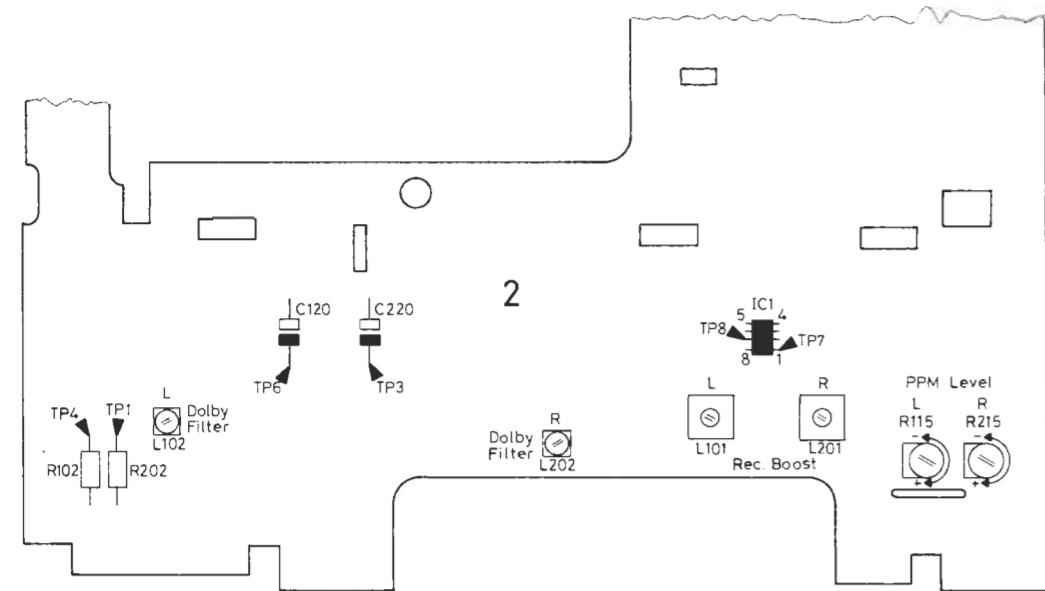
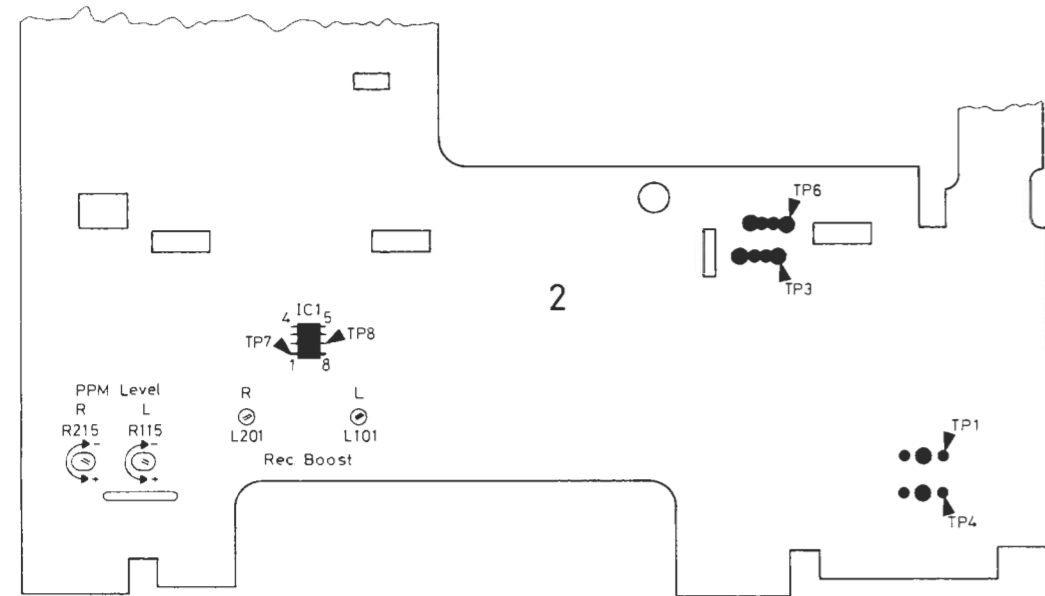

Bias and Record Current

Set the record potentiometers in mid-position.
Set 3R224A4 (3R124A3) and 3R231C8 (3R131C8) in mid-position.

Dolby Filter

Fit a 10 Mohm resistor from erase head to the Dolby input 2TP1E1 (2TP4E1).

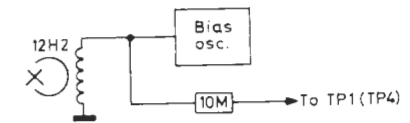

Connect AF voltmeter to 2TP3D3 (2TP6D2).
Activate Record (without AF signal applied).
Adjust 2L202E4 (2L102D2) to minimum voltage as measured in 2TP3 (2TP6).
Remove 10 Mohm resistor.

Bias Amplifier and Filter

Measure with DC voltmeter on pin 6 of P27 (pin 1 of P27) (3R251A1 (3R151A1) in relation to -15V supply).
Activate Record (with no AF signal applied).
Adjust 3L203A2 (3L103A2) and 3L202A3 (3L102A2) to minimum deflection on the DC voltmeter.

Record Current

Load CrO₂ standard test tape 6780066.
Connect tone generator to AMPLIFIER input and adjust to generate 333 Hz and approx. 300 mV.
Connect AF voltmeter to 2TP3D3 (2TP6D2).
Activate Record pause.
Adjust the Record potentiometers until a reading of 200 mV is obtained in 2TP3 (2TP6).
While recording and playing back respectively, adjust 3R231C8 (3R131C8) until a reading of 200 mV is obtained during Record as well as Play-back.

CrO₂ Bias

Load CrO₂ standard test tape 6780066.
Set tone generator to generate 333 Hz and approx. 30 mV.
Connect AF voltmeter to 2TP3D3 (2TP6D2).
Set Record potentiometers until a reading of approx. 20 mV is obtained in 2TP3 (2TP6).
While recording and playing back respectively at 333 Hz and at 15 kHz, adjust 3R224A4 (3R124A3) until the level at 15 kHz is 1 dB higher than at 333 Hz. (Less bias will result in treble boost. More bias will result in treble cut).
Check Record current.

Fe₂O₃ Bias

CrO₂ bias must be adjusted, and tone generator and record potentiometers must have the same settings as for CrO₂ bias.
Load Fe₂O₃ standard test tape 6780067.
While recording and playing back respectively, adjust 3R38A5 until the level at 15 kHz is 1 dB higher than the level at 333 Hz measured with the AF voltmeter in 2TP3.

MP Bias

CrO₂ bias must be adjusted, and tone generator and record potentiometers must have the same settings as for CrO₂ bias.
Load MP test tape 6780059.
Activate MP button (if there is no hole for METAL sensor at the back edge of the cassette).

While recording and playing back respectively 333 Hz and 15 kHz, adjust 3R40A5 until the level at 15 kHz is 1 dB higher than the level at 333 Hz measured with the AF voltmeter in 2TP3.

Bias Control

It is possible to check the bias adjustment by measuring the distortion of the 3rd harmonic of 333 Hz (K₃ distortion). The measurement can be made with the test instrument DM1 (Bang & Olufsen). The K₃ distortion must be measured with DM1 connected to the AMPLIFIER input.
Make the measurements with the standard test tapes mentioned under Bias Adjustments, and with the Record potentiometers driven to 725 mV as measured with AF voltmeter in 2TP3 (2TP6).
K₃ must be less than 2% for all three types of tapes.

ELECTRICAL DESCRIPTION
Beocord 8002

Since Beocord 8002 is a further development of Beocord 8000, only new developed circuits will be dealt with in this description.

Dolby HX Professional

Dolby HX Professional is a system which Bang & Olufsen have developed, partly in co-operation with the Dolby Laboratories; HX stands for **H**eadroom **E**xtension.

It is the objective of the system by means of an active bias regulation to get a **constant** active bias during the recording and thereby achieve a generally better utilization of the tape properties such as Max. Output Level (MOL) of the tape (MOL is an indication of how powerfully a tape can be recorded before saturation occurs).

Active Bias

In a conventional cassette recorder the bias is a high-frequency voltage with a constant amplitude and which is mixed into the AF signal to be recorded on the tape.

However, powerful treble tones in an AF signal will be perceived as bias of the tape and consequently added to the bias which is supplemented from the oscillator. The total effect is called active bias. An increase of the active bias value relative to the adjusted value will result in a deterioration of Most Output Level of high tones and in wrong bias for low tones.

The bias principle of a conventional cassette tape recorder is shown in below three diagrams.

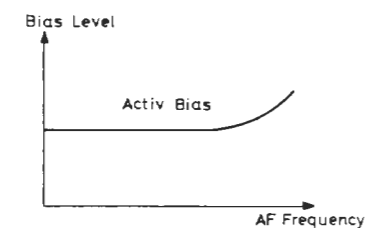
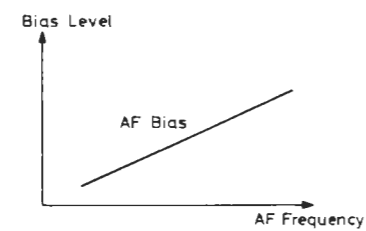
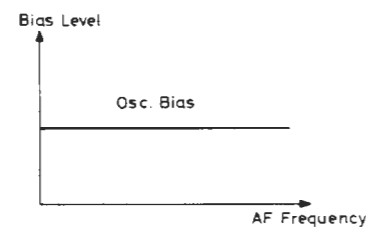

The HX Professional system controls the oscillator bias current in relation to the frequency and level of the AF signal (individually for RH and LH channels) to that the active bias value remains constant on the adjusted level irrespective of what levels and frequencies are present in the AF signal (see the three principal diagrams below).

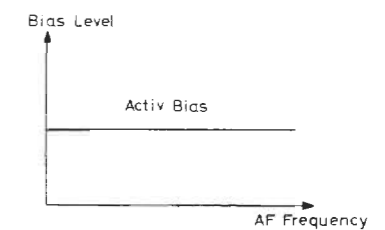
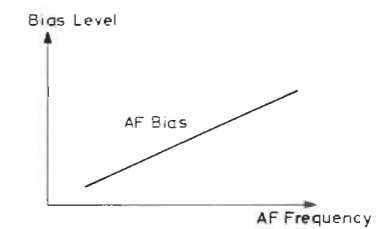
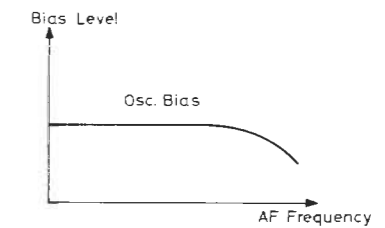

HX Professional results in an improved Max. Output Level at 10 kHz at approx. 5 dB for Fe₂O₃ and CrO₂ and 3-4 dB for MP.

Block Diagram for Active Bias

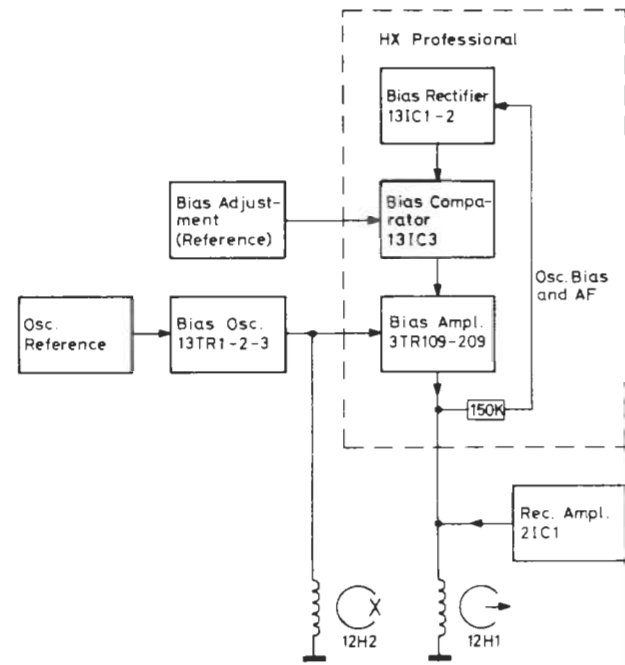

The tape head provides a signal which is a mixture of oscillator bias and AF signal. This signal is applied to a frequency-dependent rectifier which rectifies the mixed signal with the result that a varying DC voltage is obtained which is an indication of the active bias level (the DC variations are so small that they cannot be measured). The circuits are in negative feedback which all the time attempts to maintain the active bias at constant level.

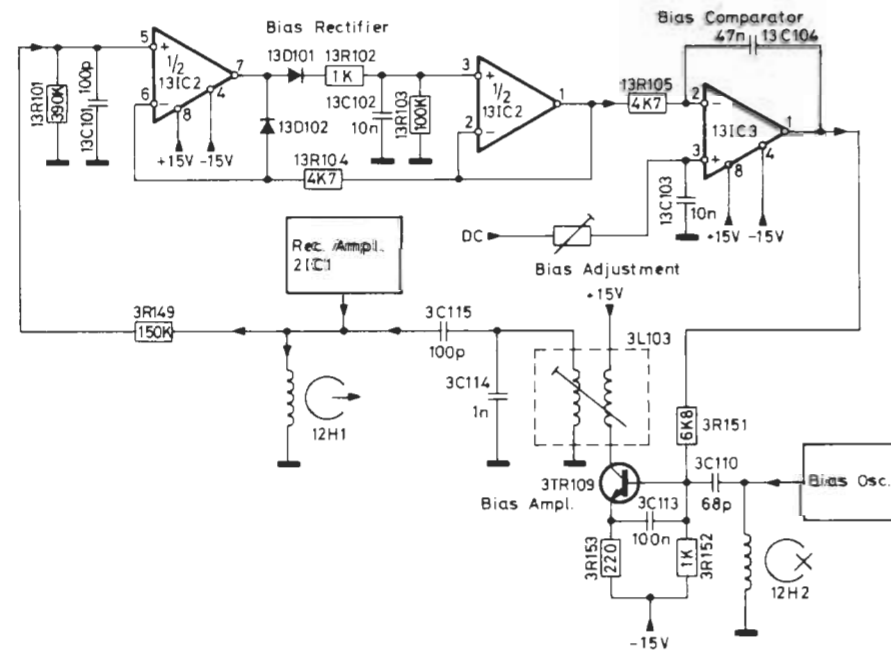

The varying DC is applied to a comparator (13IC3, pin 2) the reference (13IC3, pin 3) of which is a DC voltage which is determined by the bias adjustment. If the level on pin 2 exceeds that on pin 3 of the comparator, the level difference between the two pins becomes substantially amplified and inverted with the result that a higher negative voltage is applied to the base of 3TR109 via 3R151. This negative-going voltage determines the amplification in 3TR109 and thus how much oscillator bias is to be applied to the tape head. In other words, the circuit will all the time be adjusting itself into the same DC level as the reference level from the bias adjustment. 3L103 step-up transformer will transform the voltage wave on the collector of 3TR109 to the amplitude required.

Switch between MP and Fe₂O₃/CrO₂

MP Cassette

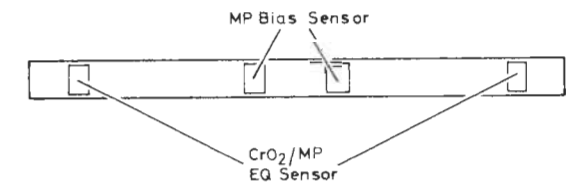

Beocord 8002 has an extra switch at the back edge of the cassette tray for automatic switching of bias and recording current between MP and Fe₂O₃/CrO₂ (play-back equalizing is the same for MP as for CrO₂). Not all MP cassettes, however, are provided with holes at the rear edge for automatic switching. When using that type of cassette, bias and record current can be forced into the MP mode by means of the MP ON/OFF button. When an MP cassette with no holes for MP bias sensor has been inserted: Prior to the cassette loading EJECT has been activated and this has resulted in a short-duration low level on the base of 3TR17, and this low level becomes inverted to high on pin 10 of 3IC4 with the result that pin 12 also goes high and remains high. 3TR16 will go ON, and since 12S5 is ON, the collector of 3TR14 will be +15 V and thus in Cr/Fe mode. When activating the MP ON/OFF button a high level is applied to pin 4 of 3IC4, and pin 2 will go high and pin 12 go low. 3TR16 and thus 3TR14 will go OFF, and the voltage on the collector of the 3TR14 will be changed to -11 V corresponding to MP mode. After EJECT and loading of a cassette with holes for MP bias sensor, 3TR16 will again be ON, but now both switches are OFF, and the voltage on the collector of 3TR14 will be -11 V. 3R63 and 3C4 are a positive feedback of the positive-going level from pin 2 to pin 4 which eliminates «bouncing» from the switch. The circuits are adjusted to Fe₂O₃ tapes with 3TR15 and 12S1 ON.

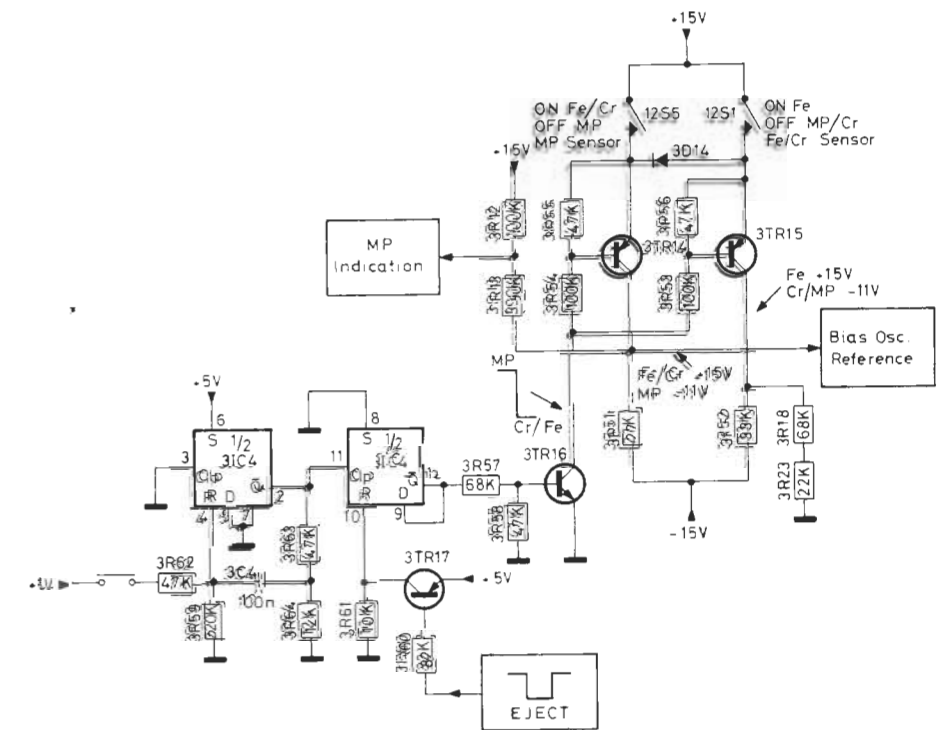

MP Indicator

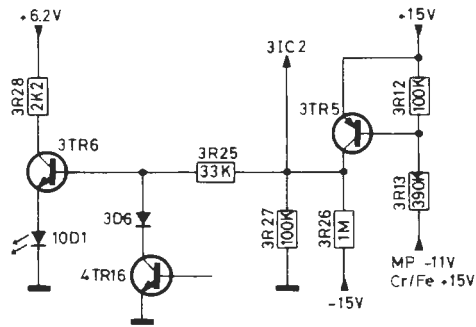

In MP mode 3TR5 will go ON, its collector will become positive, 3TR6 will go ON and the MP indicator 10D1 will glow.

With no cassette in the cassette tray both 12S5 and 12S1 are OFF, and -11 V will be applied to 3R13, and as this would result in 10D1 glowing, 3D6 has been introduced.

With an empty cassette tray 4TR16 is ON, and the voltage on the base of 3TR6 is conducted to chassis via 3D6 and 4TR16.

HX Reference

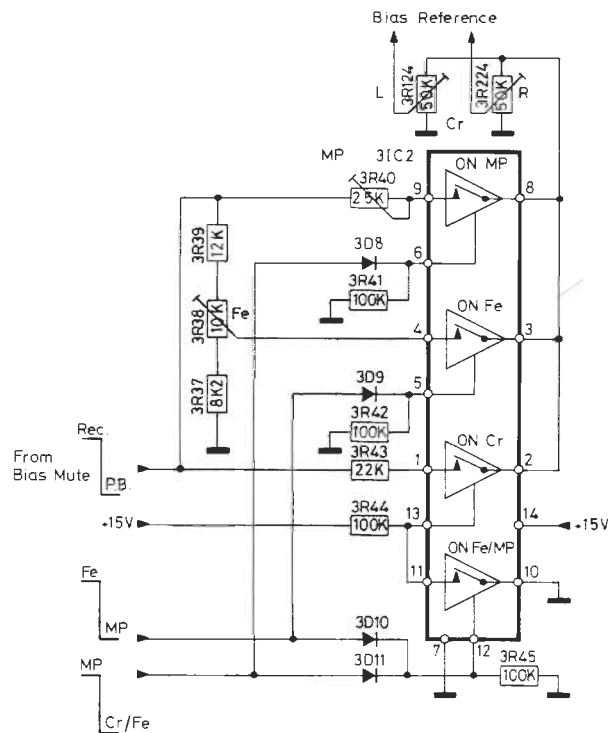

The bias reference voltages for the three types of tapes are conveyed to the HX system via 3IC2 which contains four switch sections. The references are adjusted by first to adjust CrO₂ and separately for RH and LH channels (3R124 and 3R224), so that any channel difference is equalized at the CrO₂ adjustment. The adjustment for MP and Fe₂O₃ is common for RH and LH channels (MP 3R40/Fe₂O₃ 3R38).

Block Diagram for AF Circuit

--- Signal path record
 - - - - - Signal path play back

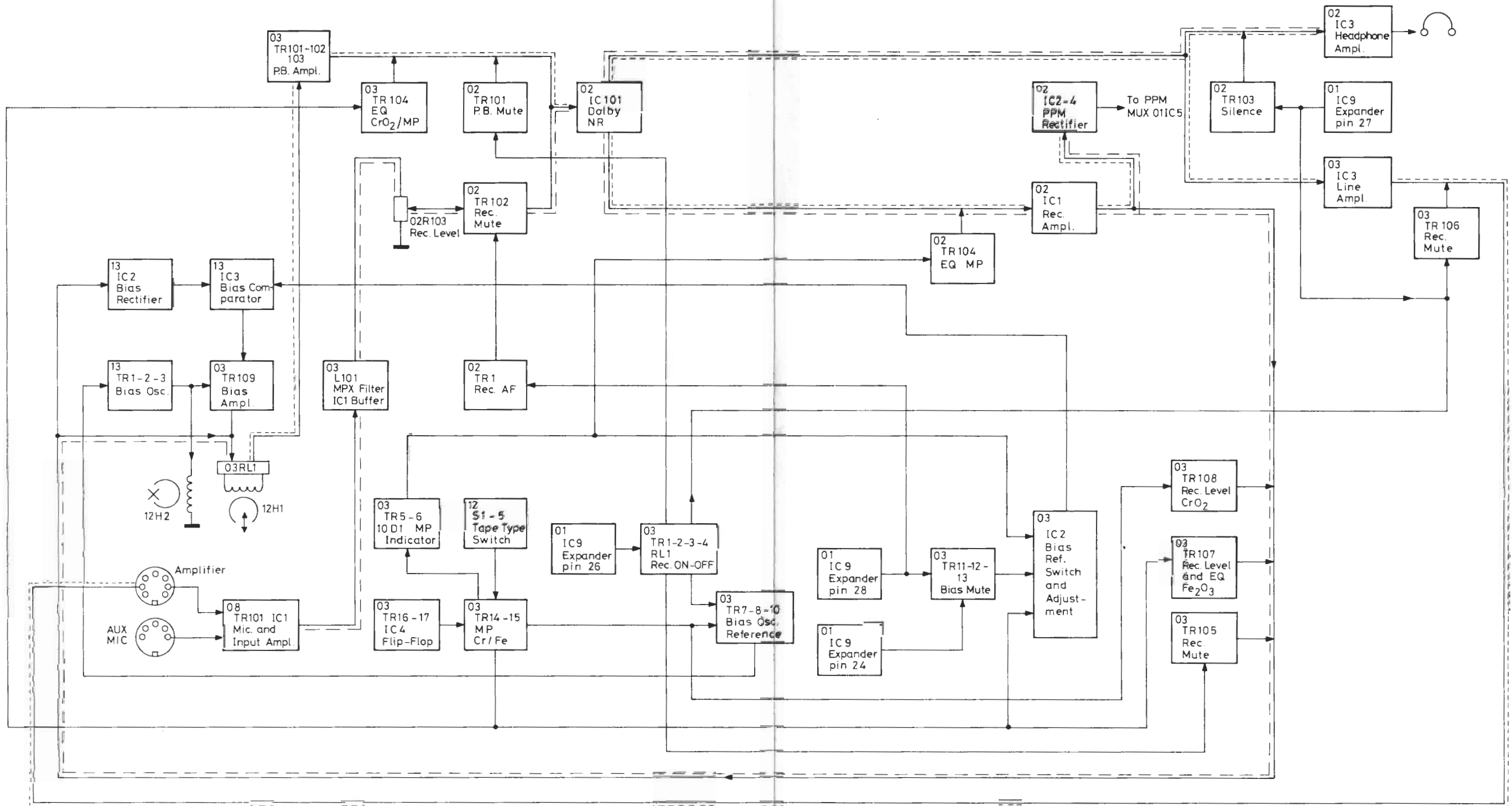

TECHNICAL SPECIFICATIONS
Beocord 6000

Compact cassette	C46-C60-C90-C120
Tape head	Sendust
Noise reduction	Dolby B
Tape switch	Aut. ferro/chrom/manual metal
Wow and flutter DIN	<±0.1%
Wow and flutter WRMS	<0.045%
Speed deviation	<±1%
Fast forward and rewind C60	70 sec.
Frequency range chrom/metal/ferro	30-16,000 Hz ±2.5 dB (with MPX filter)
Signal-to-noise ratio metal Dolby NR	>68 dB
Signal-to-noise ratio chrom Dolby NR	>66 dB
Signal-to-noise ratio ferro Dolby NR	>64 dB
Signal-to-noise ratio metal	>60 dB
Signal-to-noise ratio chrom	>58 dB
Signal-to-noise ratio ferro	>56 dB
Drivability metal	<8 dB
Drivability chrom	<15 dB
Distortion metal	<2.5%
Channel separation	>35 dB
Erase	>70 dB
Erase frequency	96 kHz
Radio input DIN-LINE	1 mV/10 kohms - 40 mV/470 kohms
Microphone input	0.1 mV/3 kohms
AUX input	100 mV/1.2 Mohms
Radio output adjustable	800 mV (500-2000 mV)/2 kohms
Headphones	Max. 5 V/56 ohms
Power consumption	Max. 50 W
Dimensions W x H x D	53 x 13 x 30 cm
Weight	7.5 kg
Type 4831	114V
Type 4832	120V
Type 4833	127V
Type 4834	220V
Type 4835	240V
Type 4836	240V
Type 4837	105V
Frequency	50-60 Hz
Subject to change without notice	

Power Supply
Beocord 8002

Compact cassette	C46-C60-C90-C120
Tape head	Sendust
Noise reduction	Dolby B
Tape switch	Aut. ferro/chrom/metal
Wow and flutter DIN	<±0.1%
Wow and flutter WRMS	<0.045%
Speed deviation	<±1%
Fast forward and rewind C60	70 sec.
Frequency range chrom/metal/ferro	20-20,000 Hz ±3 dB
Signal-to-noise ratio metal Dolby NR	>68 dB
Signal-to-noise ratio chrom Dolby NR	>66 dB
Signal-to-noise ratio ferro Dolby NR	>64 dB
Signal-to-noise ratio metal	>60 dB
Signal-to-noise ratio chrom	>58 dB
Signal-to-noise ratio ferro	>56 dB
Drivability metal	>-5 dB
Drivability chrom/ferro	>-8 dB
Distortion metal	<2%
Channel separation	>35 dB
Erase	>70 dB
Erase frequency	96 kHz
Radio input DIN-LINE	1 mV/10 kohms - 40 mV/470 kohms
Microphone input	0.1 mV/3 kohms
AUX input	100 mV/1.2 Mohms
Radio output adjustable	1000 mV (500-2000 mV)/10 kohms
Headphones	Max. 10 V/56 ohms
Power consumption	Max. 50 W
Dimensions W x H x D	53 x 13 x 30 cm
Weight	7.5 kg
Type 4841	114V
Type 4842	120V
Type 4843	127V
Type 4844	220V
Type 4845	240V
Type 4846	240V
Type 4847	105V
Frequency	50-60 Hz
Subject to change without notice	

Power Supply

ADSKILLELSE DISASSEMBLY

Serviceposition: Skruerne A løsnes
Service position: Loosen screw A

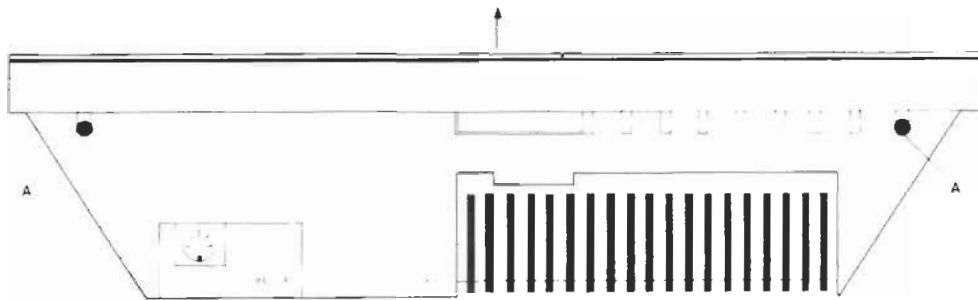

Betjeningspanel
Operating panel

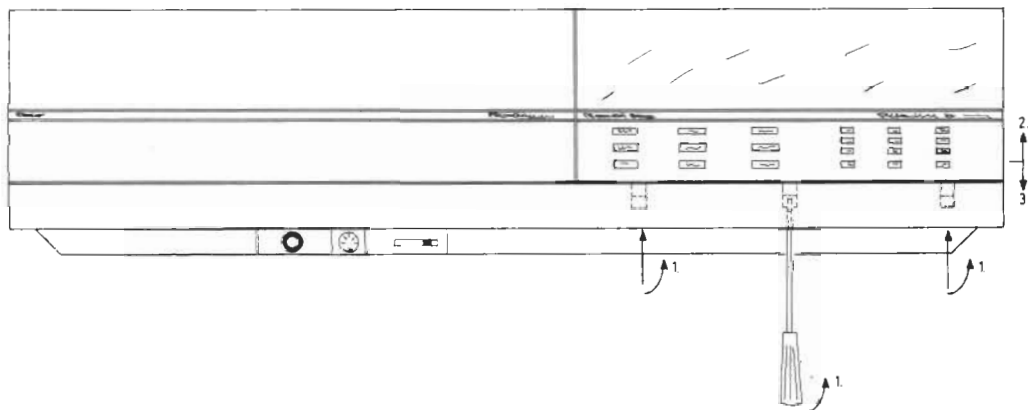

Display dæksel
Cover for display

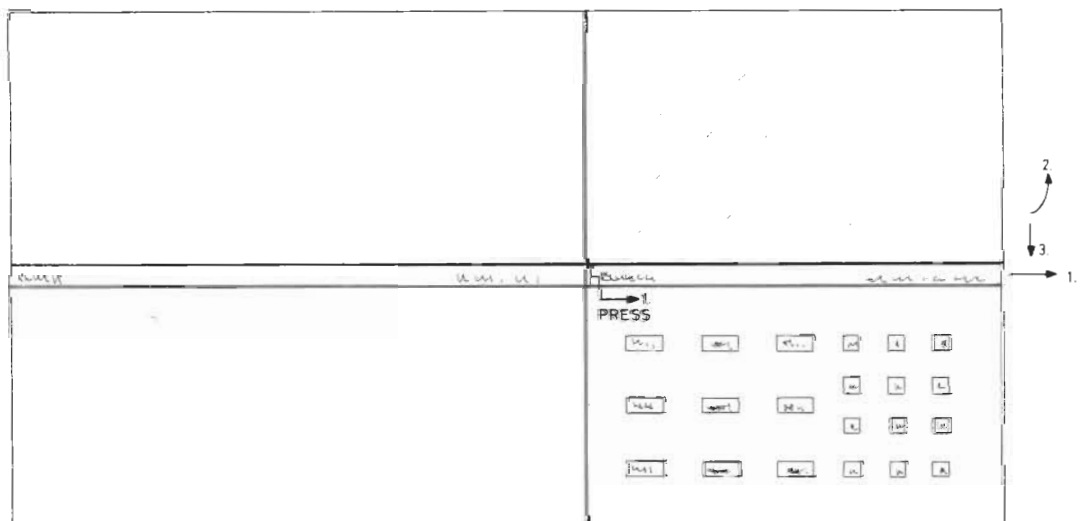

Toppanel og vippelåg
Cover and panel

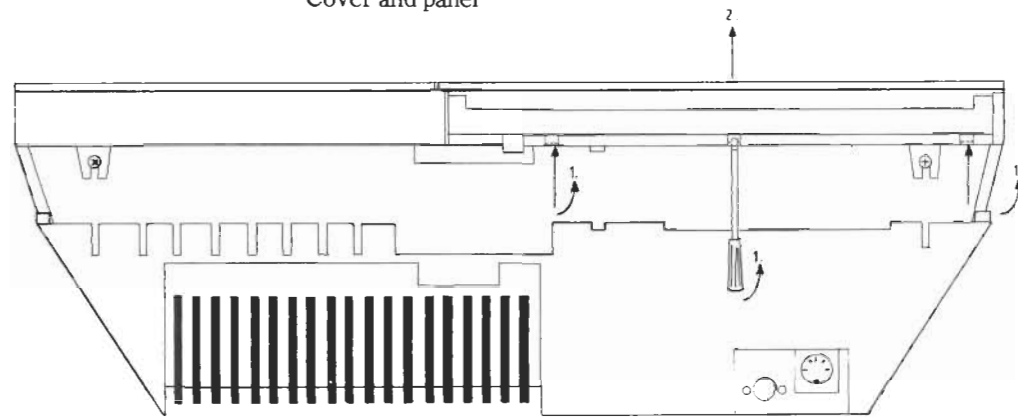

Aluminiumsdækplade
Aluminium cover

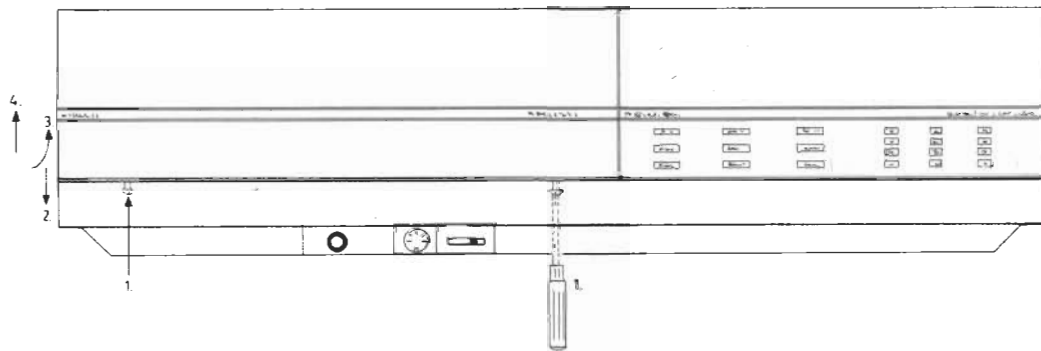

Power enhed
Power unit

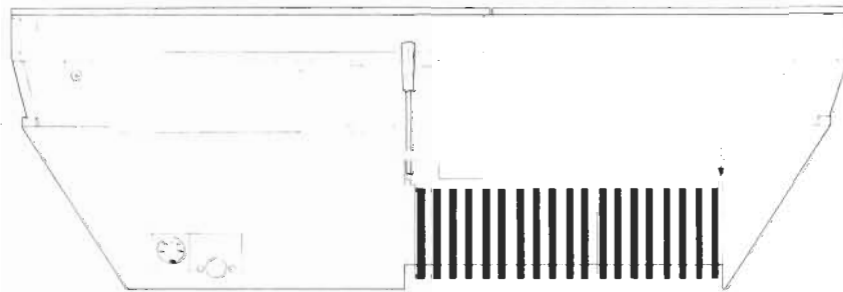

INSULATION TEST

Insulation test for
Beocord 6000-8002

Each set **must** be insulation tested after dismantling. The test is to be performed when the set has been re-assembled and is ready for delivery to the customer.

Make the insulation test as follows: – Short-circuit the two plug pins of the mains plug and connect one of the terminals of the insulation tester. Connect the other terminal of the insulation tester to the chassis pin of the headphone socket.

N.B.!

To avoid tuning the set, it is essential that both insulator test terminals are in really good mechanical contact.

Now turn slowly the **voltage control** of the insulation tester until a voltage of 1.5–2 kV is obtained. Hold it there for 1 second, then turn slowly the voltage down again.

At no point during the testing procedure any flash-overs are permissible.

SERVICE TIPS AND MODIFICATIONS
Plug Survey

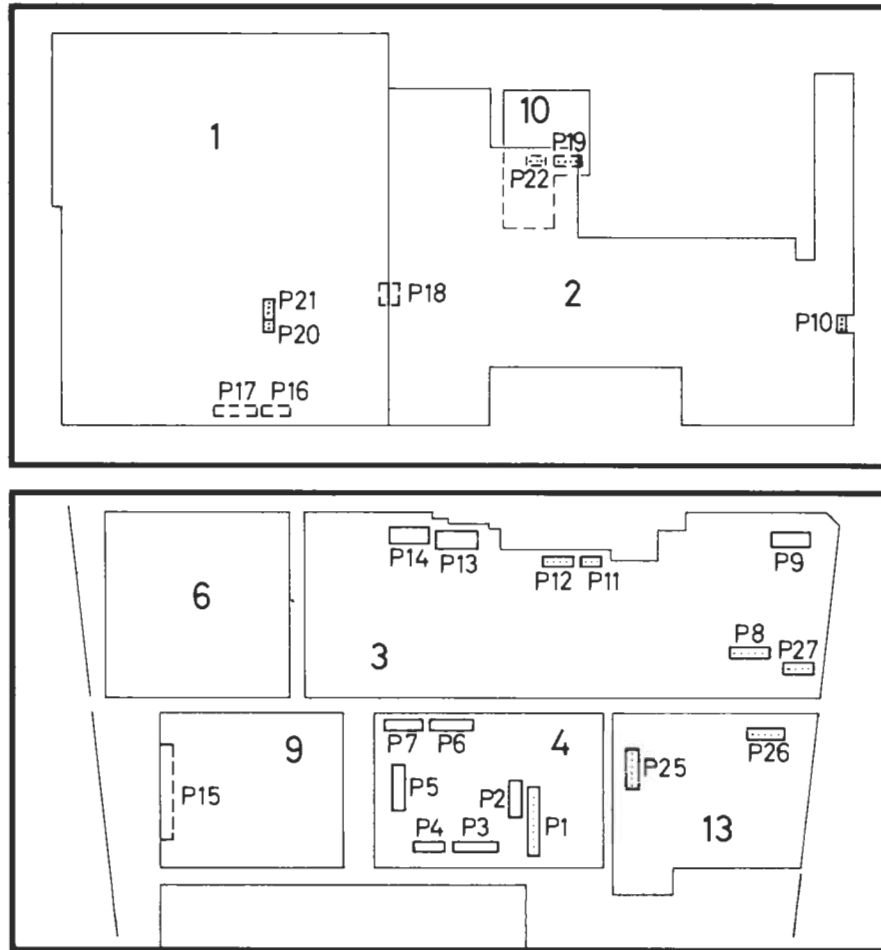

Wow frequencies

Frequency	Source of Failure	Pos. No.
1,1 Hz	Thrust roller	12049
1,3 Hz	Take-up reel	12044
4,3 Hz	Drive belt	12162
4,5 Hz	Take-up belt	12140
5,2 Hz	Idler wheel	12041
6,0 Hz	Flywheel	12161
11,8 Hz	Cluth	12135
36,5 Hz	Pulley	12101

Dolby IC

In the current production of Beocord 6000 the Dolby IC has been modified to another type.

Old type: LM1011AN 8340183

New type: LM1111BN 8340295

Diagrams of the two types are shown in below diagram sections. The two types of ICs are not compatible.

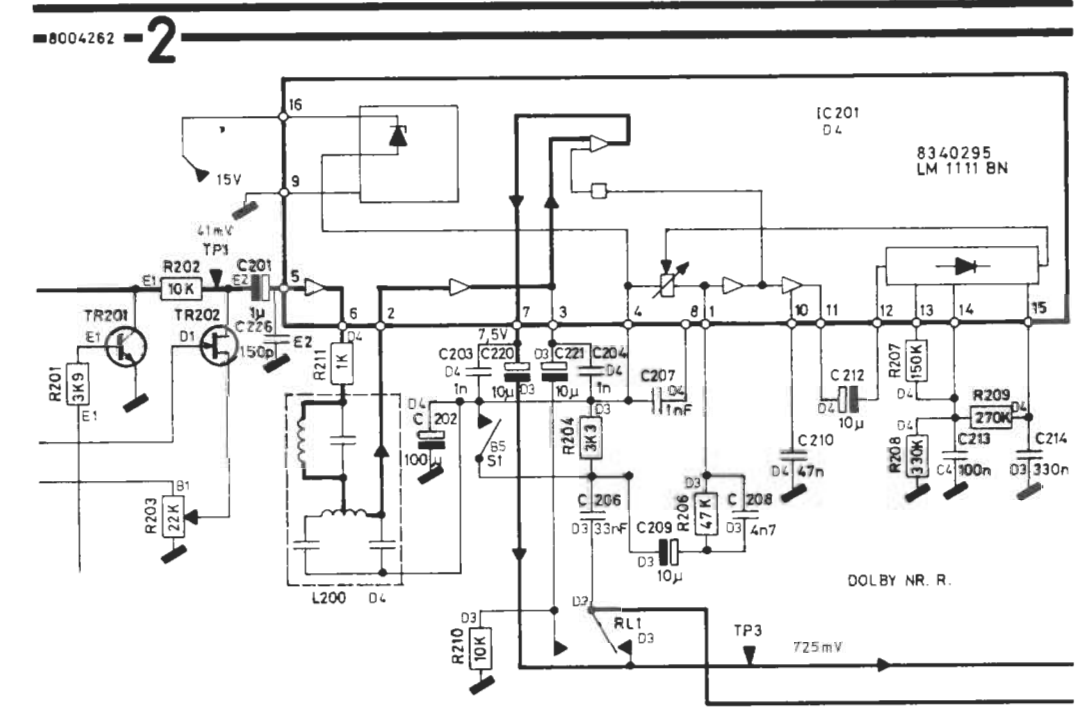
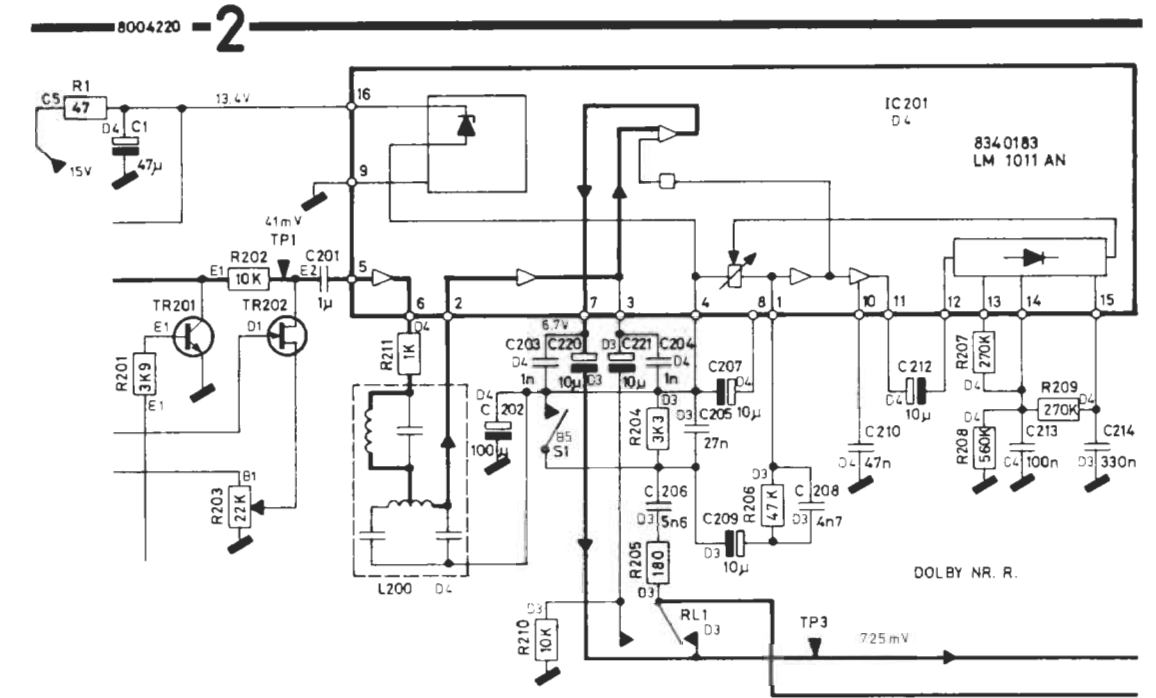

END TEST

By carrying out the following procedure a test check-out of all the functions of the set is performed

OPERATION		FEED-BACK		
Comments	Enter	Indicator	Display	Tape Transport
1 Connect to Beomaster and to mains	XXXX	XXXX	□□:□□ and □□'□□	XXXX
2	0 → 9 CE GO	XXXX	Follows entry □□:□□ and □□'□□ □□'□□ and □□'□□	XXXX
3	TIME SET TIMER START TIMER STOP	XXXX	Time from connection e.g. □□:□□ and □□'□□ □□'□□ and □□'□□ □□'□□ and □□'	XXXX
4 Insert prerecorded tape	<< >> >	XXXX Reading on PPM	Flashes □□'□□ Flashes □□'□□ Measures tape in real time □□'□□ □□'□□ Flashes twice □□'□□ Actual tape time Measures tape in real time □□'□□ and □□'□□	<< >> > XXXX Stop > Stop and tape ejects
5 Insert tape for recording from the start of the tape (Not a MP cassette)	REC OPEN RECORD Adjust REC level RECORD STOP (note time for entry) MP ON-OFF MP ON-OFF	REC-OPEN Flashes RECORD PPM follows REC level Constant RECORD Flashes RECORD, reading on PPM disappears for approx. 4 secs. MP ON MP ON goes off	□□'□□ and □□'□□ XXXX Measures tape in real time Measures tape in real time for approx. 4 secs., then shows actual tape time	XXXX > > for approx., 4 secs., then stop

OPERATION		FEED-BACK		
Comments	Enter	Indicator	Display	Tape Transport
	RECORD	Constant RECORD	Measures tape in real time	>
	MEMORY +	Constant MEMORY	XXXX	XXXX
6	RETURN when first digit shows □	Flashes RECORD	Measures tape in real time shows approx. time for STOP entry, measures for approx. 4 secs., then actual tape time	<<,>, stop,>, stop
	>>	RECORD goes off, flashes MEMORY	Measures tape in real time to memory point	>>, stop
	MEMORY -	MEMORY goes off	XXXX	XXXX
	STAND BY	XXXX	Only upper point lights	XXXX
7 Check of pre-corded tape by listening via headphones and Beomaster. Check of record/replay with and without Dolby by listening via headphones and Beomaster. Check of record/replay with and without MPX filter by listening via headphones.				