

Bang & Olufsen

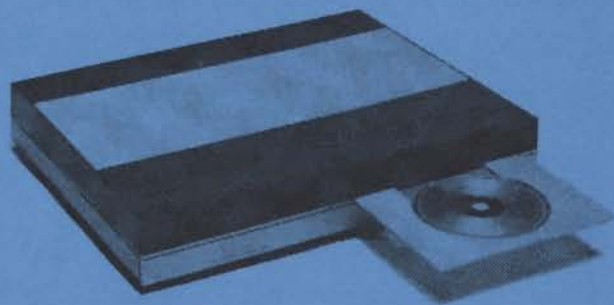

BEOGRAM CD 5500

TYPE 5131, 5132, 5133, 5134, 5135

BEOGRAM CD 6500

TYPE 5136, 5137, 5138, 5139, 5140

BEOGRAM CD 7000

TYPE 5151, 5152, 5153, 5154, 5155



INDHOLD

| | | | |
|--|----|--|----|
| Moduloversigt | 1 | Survey of modules | 1 |
| Tekniske specifikationer | 1 | Technical specifications | 1 |
| Diagrammer | 2 | Circuit diagrams | 2 |
| Elektrisk stykliste | 3 | List of electrical parts | 3 |
| Mekanisk stykliste | 4 | Mechanical part list | 4 |
| Kontrol, justeringer | 5 | Control, Adjustments | 5 |
| Adskillelse | 6 | Dismantling | 6 |
| Reparationstips | 7 | Repair hints | 7 |
| Isolationstest | 8 | Insulation test | 8 |
| Kredsløbsbeskrivelse | 9 | Circuit description | 9 |
| Diagram, PCB tegning og stykliste til PCB30 uden focus off-set justering | 10 | Diagram, PCB drawing and partlist for servo PCB30 without focus off-set adjustment | 10 |

CONTENTS

Modules

| | |
|----------------------------|-------------|
| 1 Display | diagr. C |
| 2 Contact PCB | diagr. C |
| 5 Decoder | diagr. B, C |
| 6 Motor | diagr. C |
| 7 Optocoupler | diagr. C |
| 8 Mains Transformer | diagr. C |
| 9 Socket panel | diagr. B |
| 10 DIN socket | diagr. B |
| 11 PCB f. Flex Print | diagr. A |
| 30 Servo | diagr. A |
| 96 Mechanism | diagr. A |
| Eject switch | diagr. C |

**CLASS 1
LASER PRODUCT**

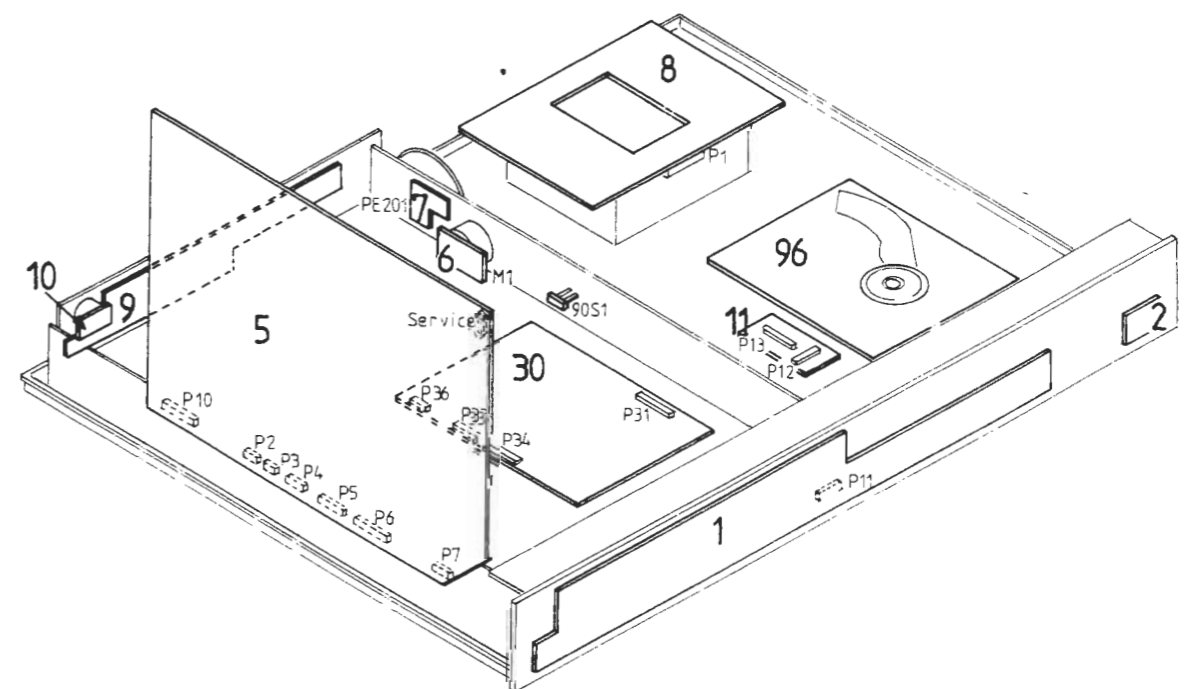

TECHNICAL SPECIFICATIONS

| | |
|---------------------------------|--|
| Frequency range | 3-20.000 Hz \pm 0.3 dB |
| Signal-to-noise ratio | >100 dB/110 dB A-weighted |
| Dynamic range | >96 dB |
| Harmonic distortion incl. noise | <0.0025% at 0 dB <0.025% at -20 dB |
| Channel separation | >101 dB |
| Channel difference | <0.08 dB |
| Converter system | 2 x 16 bit, 4 x oversampling 176.4 kHz |
| Low pass filter | Digital + Bessel/elliptical analog |
| Damping >20.000 Hz | >50 dB |
| Phase error between L and R | 0 degrees at 20-20.000 Hz |
| Output, analog | 1.3 V RMS at 0 dB |
| Output, digital | For digital equipment |
| Power supply | Type no. 5131: 220 V Type no. 5132: 240 V Type no. 5133: 120 V Type no. 5134: 100 V Type no. 5135: 240 V |
| Power frequency | 50-60 Hz |
| Power consumption | 23 watts |
| Dimensions W x H x D | 42 x 7.5 x 32.5 cm (16 ¹ / ₂ " x 3" x 12 ³ / ₄ ") |
| Weight | 6.3 kg (13.9 lbs) |

Subject to change without notice

DIAGRAMFORKLARING

På diagrammet er der angivet typenumre på transistorer og IC'er i de tilfælde hvor typenummeret er entydigt for komponentens placering i kredsløbet - f.eks. TR20/BC 557B

Hvis positionsnummeret er efterfulgt af en stjerne skal reservedelsnummeret benyttes, da denne komponent er specielt udvalgt - f.eks. TR102*.

Ledningsforbindelser

Ledningsforbindelserne på diagrammet er samlet i »bundter«. De enkelte ledninger er forsynet med koder, der fortæller hvortil de går.

INTERN FORBINDELSE
PÅ EN DIAGRAMSIDE

Interne forbindelser på en diagramside angives med et tal. Knækket på ledningen viser i hvilken retning den anden ende af ledningen findes.

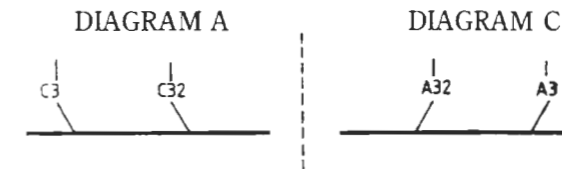
FORBINDELSE TIL EN ANDEN
DIAGRAMSIDE

Forbindelsen til en anden diagramside angives med et tal, samt bogstav indikation på det diagram forbindelsen går til.

Forsyningsspændinger

En pil og spændingen viser, hvor forsyningsspændingen går ind i et print.

Eksempel: Ved siden af forsyningsspændingen står f.eks. 7 CON. Det betyder at denne pil, og dermed forsyning går til 7 steder på denne diagramside (7 CON. = 7 connections).

Symbol for sikkerhedskomponenter

Ved udskiftning af komponenter med dette symbol skal der anvendes komponenter med samme reservedelsnummer. Den nye komponent skal monteres på samme måde som den udskiftede.

EXPLANATION OF DIAGRAM

Type numbers of transistors and IC's have been indicated on the diagram in those cases where the type number is unambiguous for the position of the component in a circuitry - e.g. TR20/BC 557B.

If the position number is followed by an asterisk the spare part number **must be used** because this component has been especially selected - e.g. TR102*.

Wiring Connections

The wiring connections on the diagram are assembled in "bundles". The individual wires are coded to indicate to where they are leading.

INTERNAL CONNECTION
ON ONE DIAGRAM PAGE

Internal connections on a diagram page are indicated by a number. The bend of the wire indicates in which direction the other end of the wire may be found.

CONNECTION TO ANOTHER
DIAGRAM PAGE

Connections to another diagram page are indicated by a number, as well as by a letter of the diagram to which the connections lead.

Supply Voltage

An arrow and the voltage show where the supply voltages are fed to a PCB.

Example: Next to the supply voltage it says e.g. 7 CON. This means that this arrow, and thus the supply goes to 7 different places on this diagram pages (7 CON. = 7 connections).

Symbol for Safety Components



When replacing components with this symbol components with identical part numbers are to be used. The new component must be fitted in the same way as the one replaced.

DIAGRAM A (Servo and Disc Motor System)

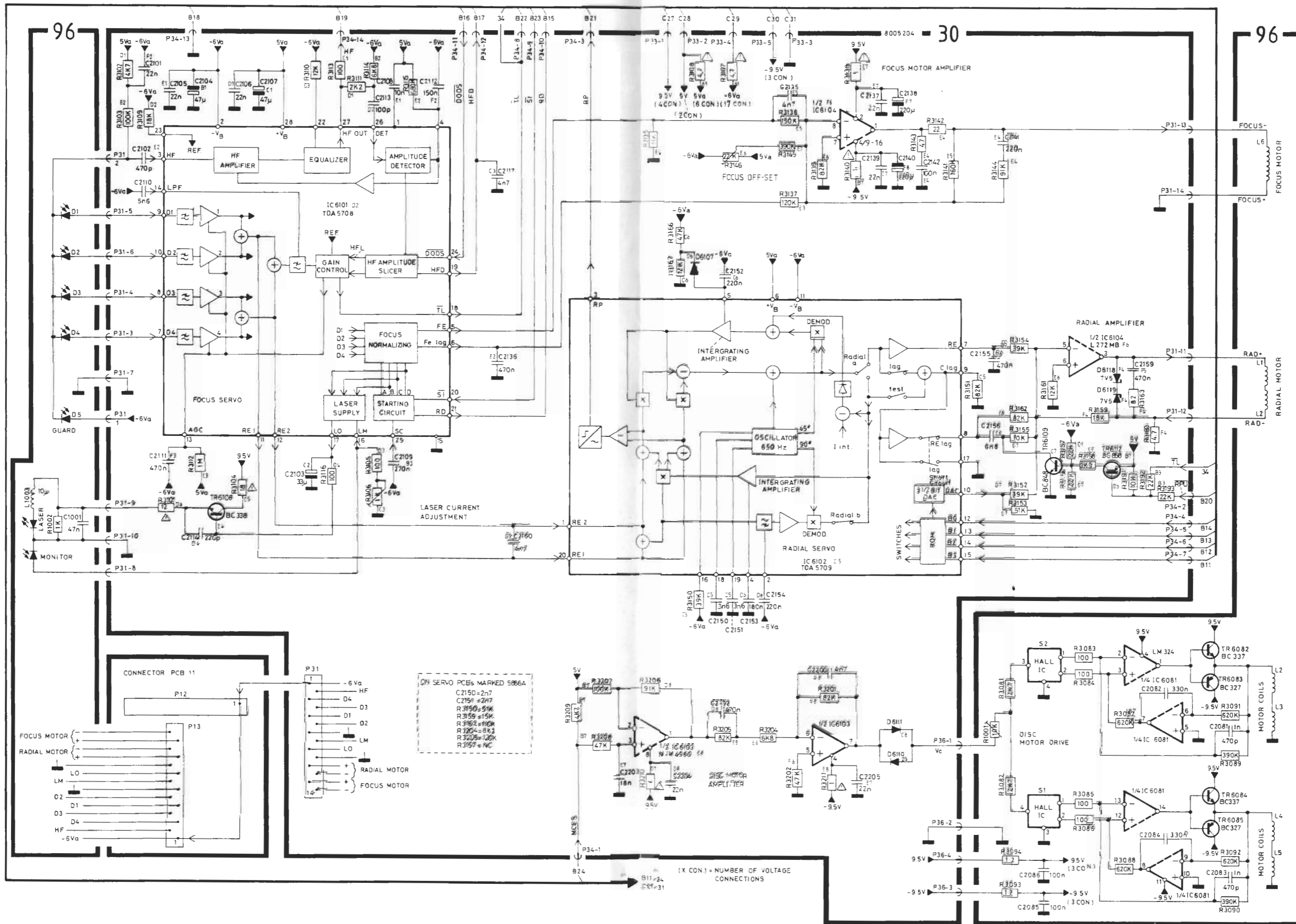

SERVO PCB 30

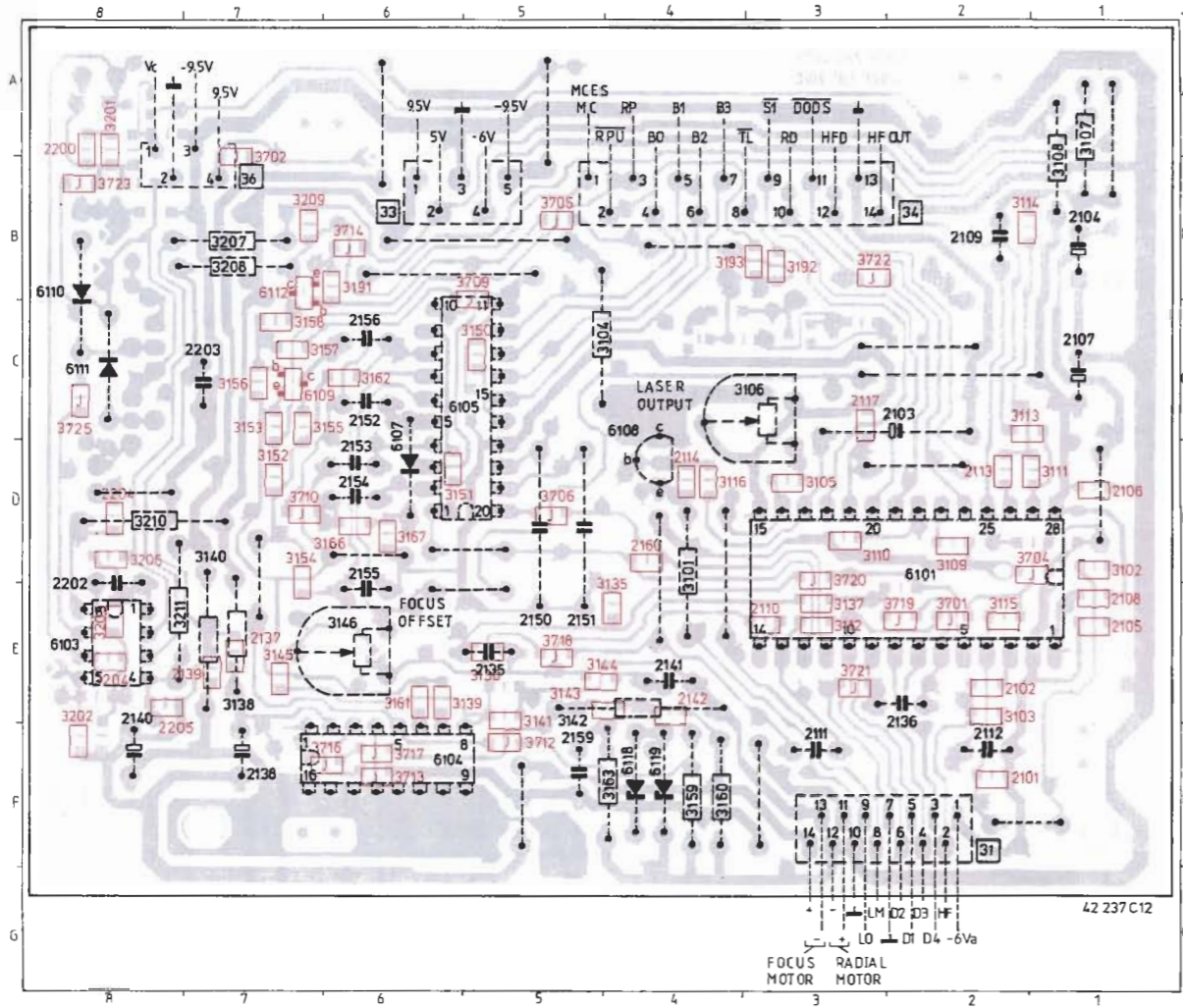

DISC MOTOR CONTROL

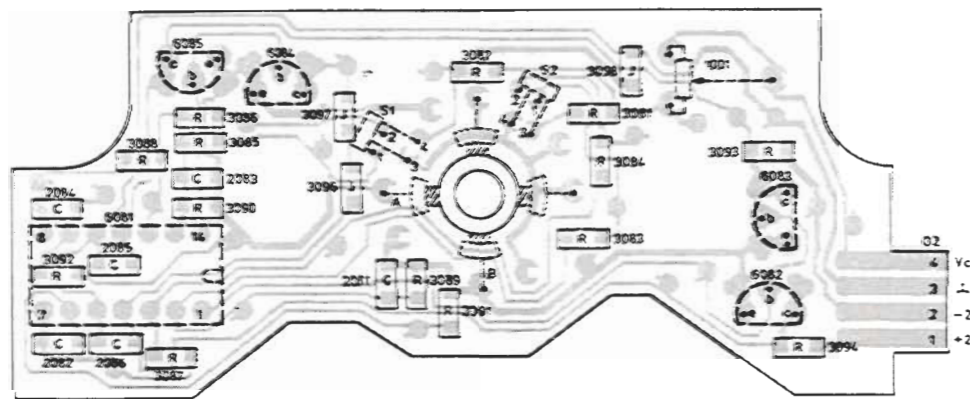

SERVO PCB 30

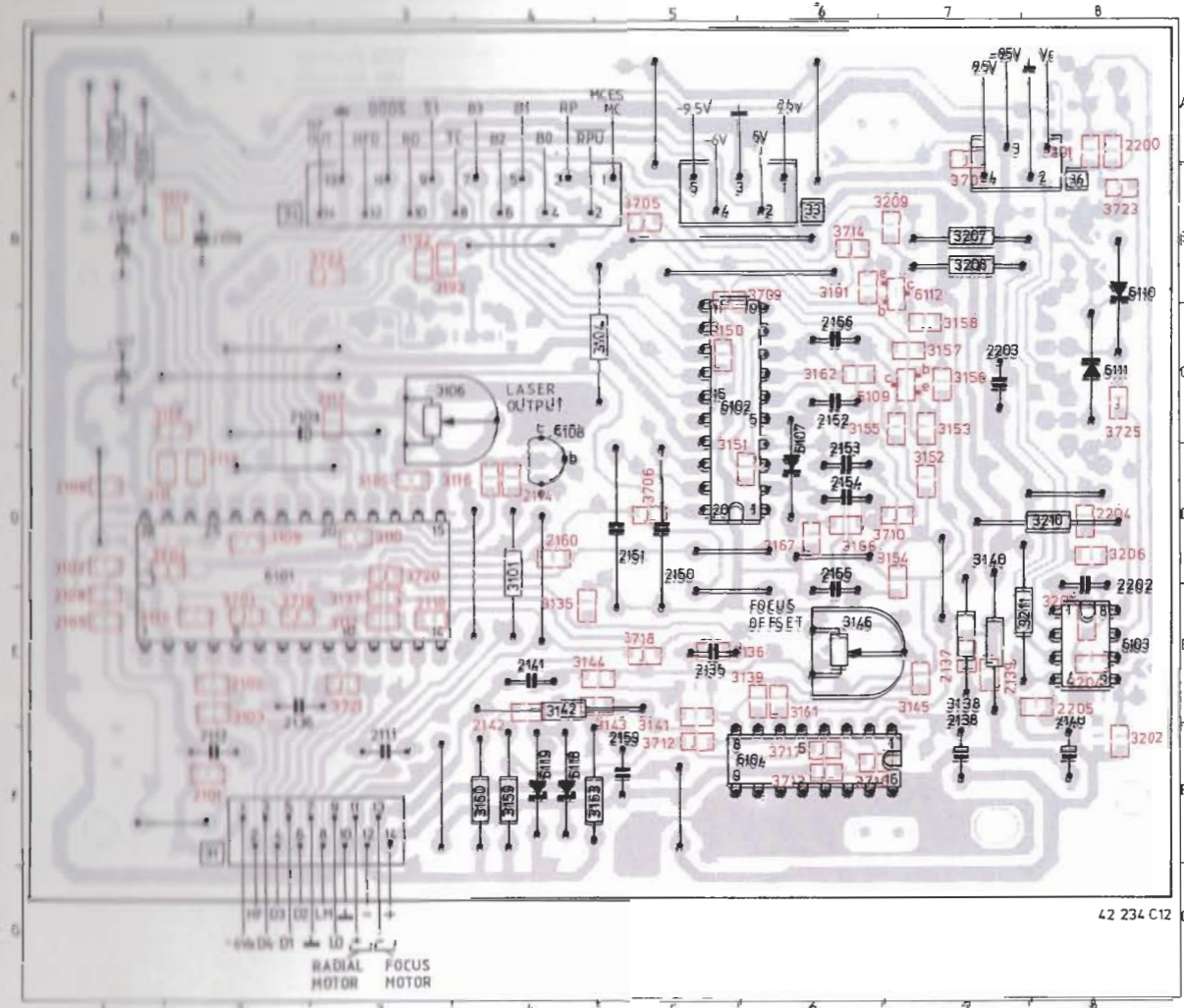

DISC MOTOR CONTROL

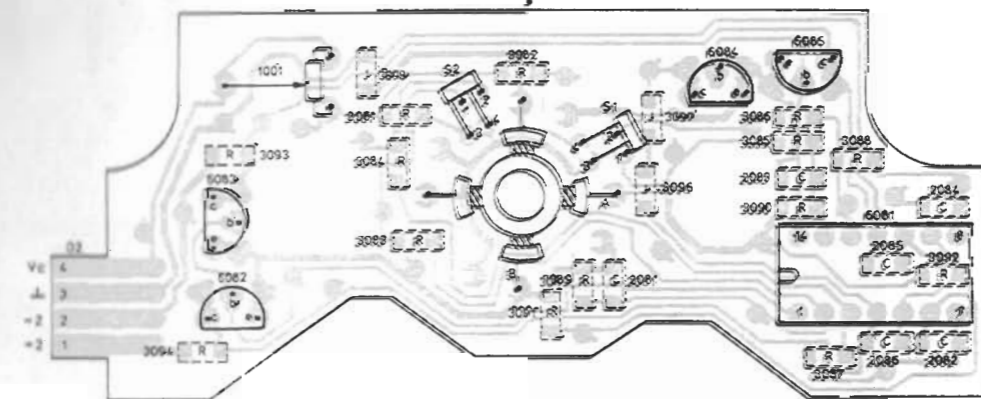
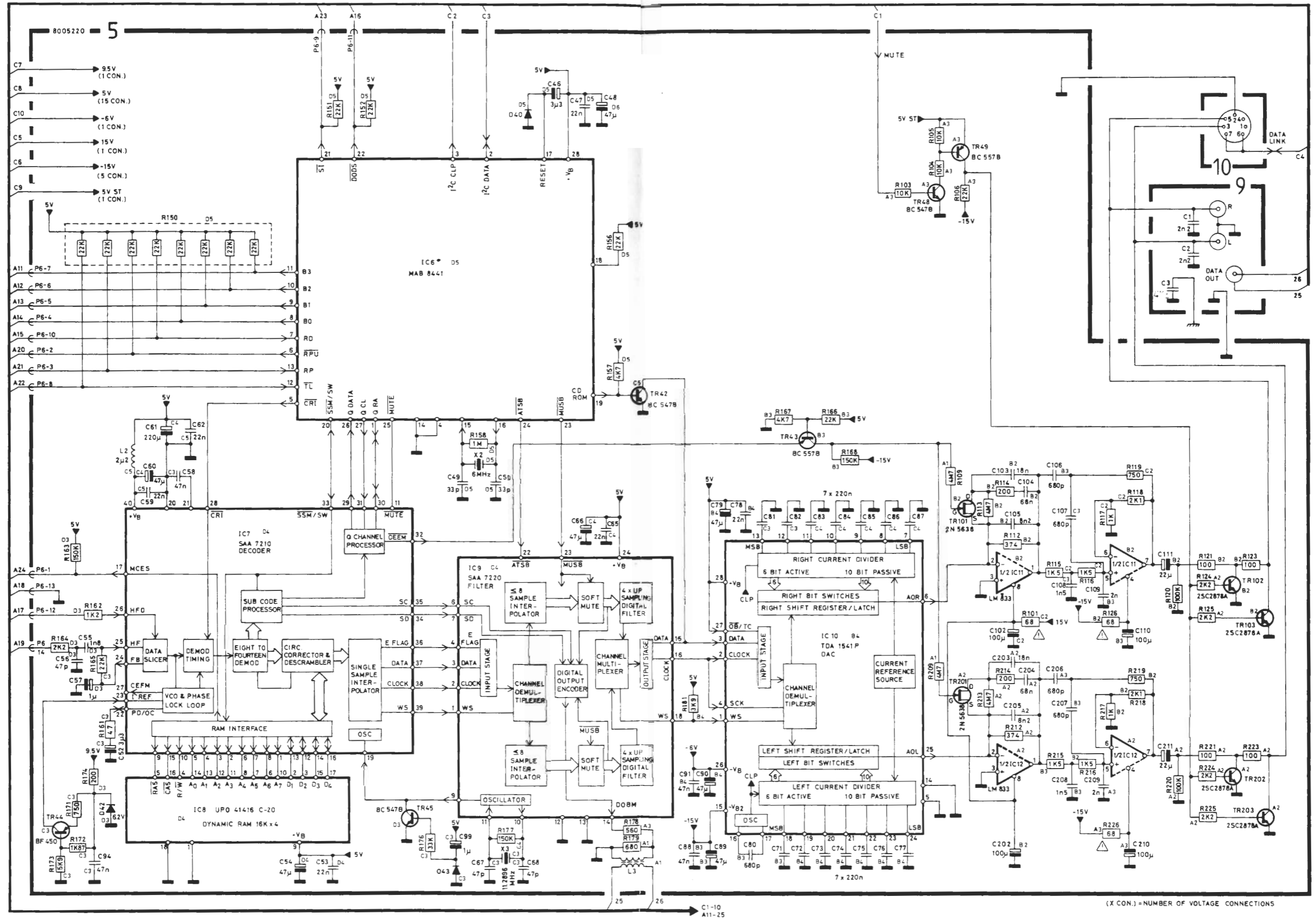
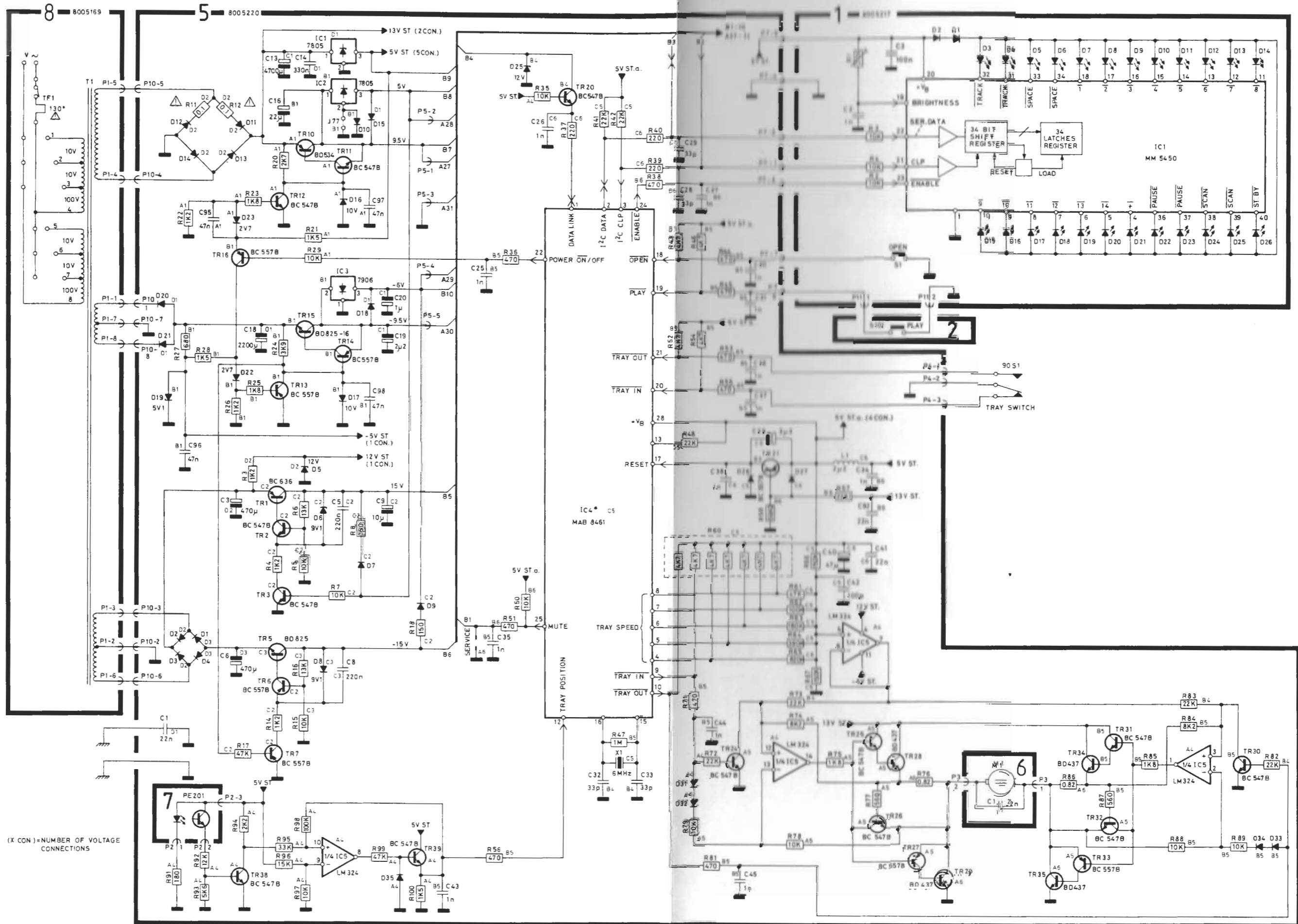

DIAGRAM B (Decoder)



(X CON.) = NUMBER OF VOLTAGE CONNECTIONS

DIAGRAM C (Power Supply, Control and Display)



(X CON.) = NUMBER OF VOLTAGE CONNECTIONS

BLOCK DIAGRAM

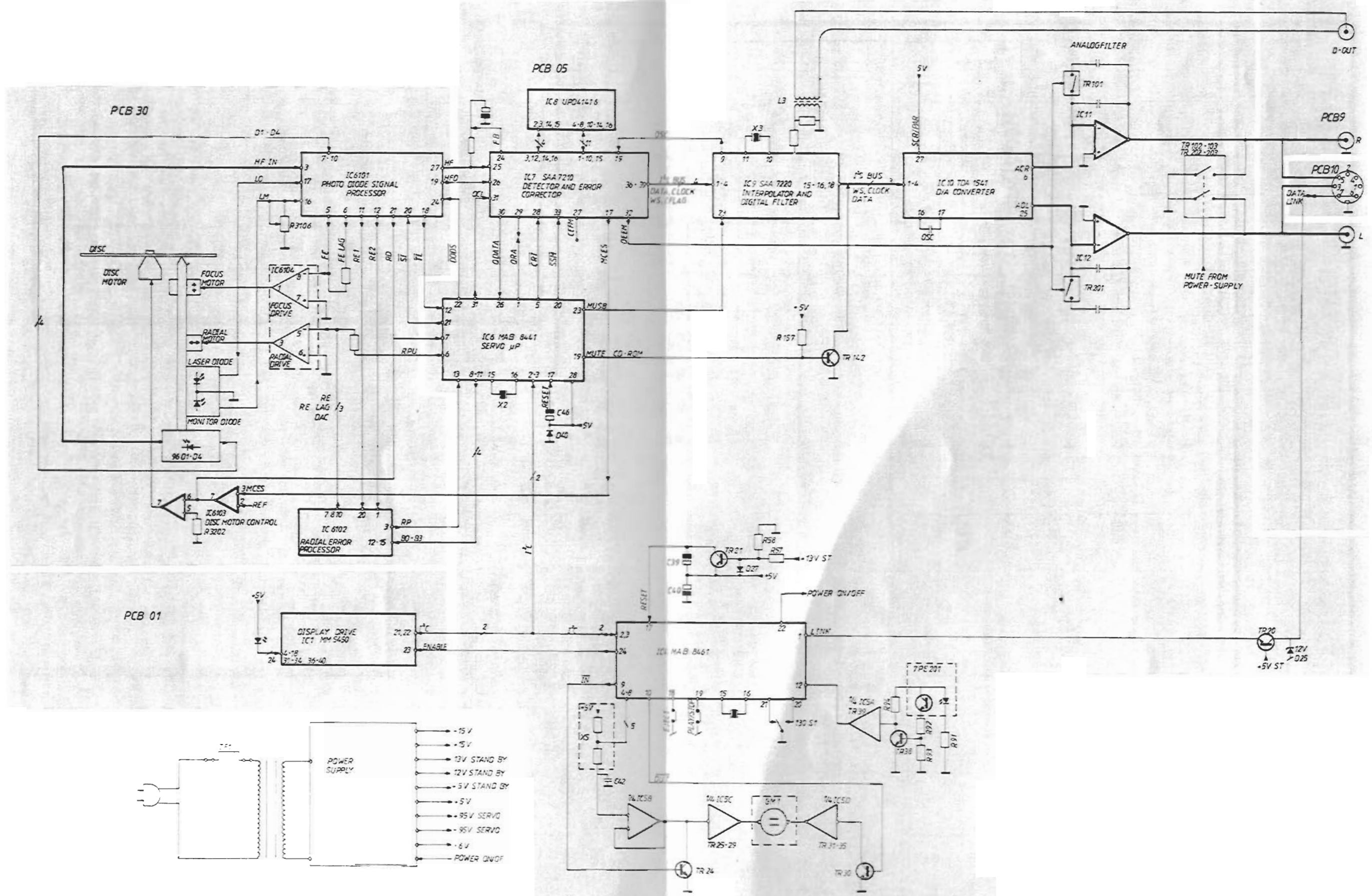

LIST OF ELECTRICAL PARTS

In the player chip components have been applied. For insertion and removal of chip components see the figure below.

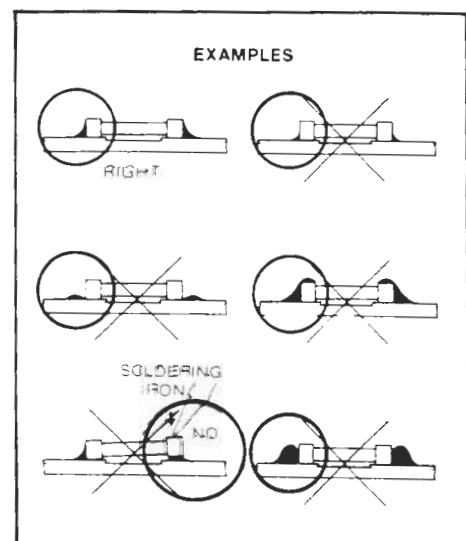
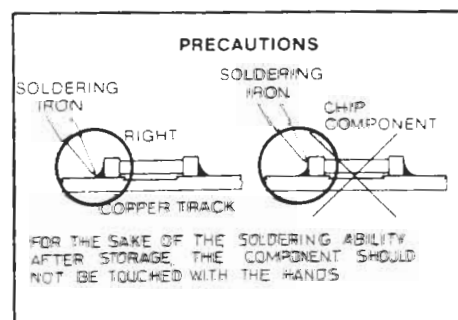
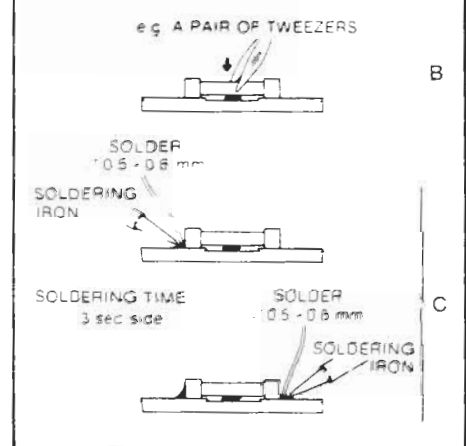
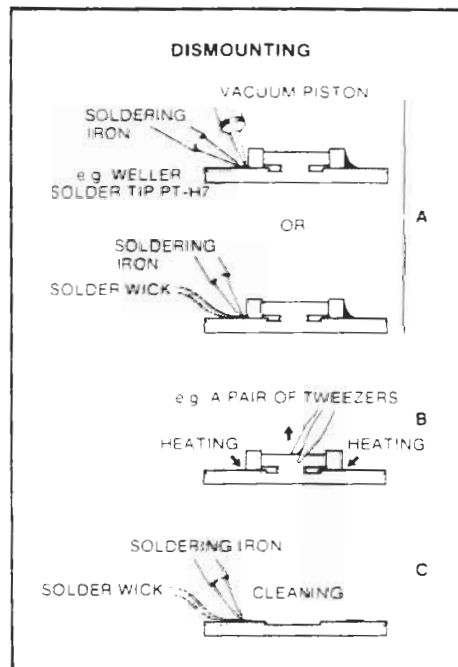
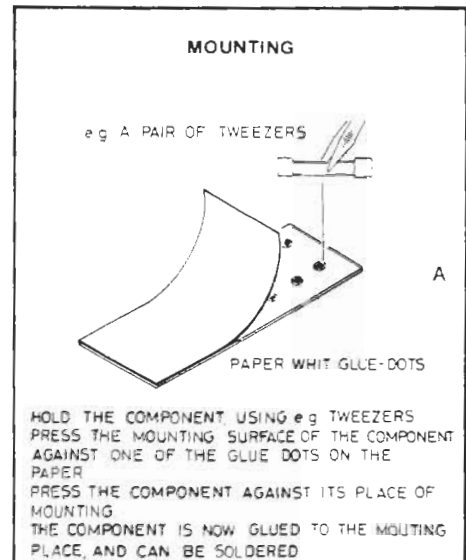
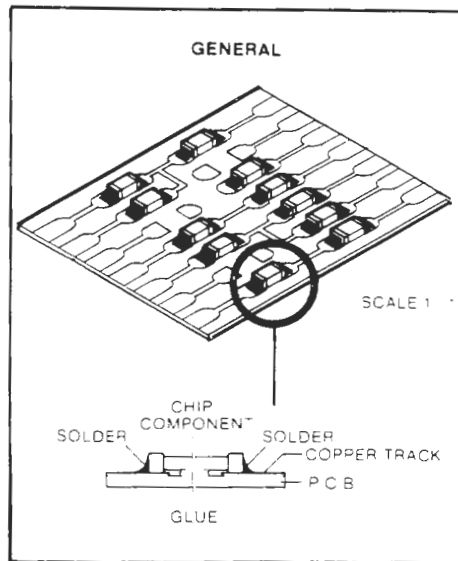

Standard resistors:

Resistors SMD 5% 1/8 W

Resistors not mentioned are standard resistor.

| | X1 | X10 | X100 | X1K | X10K | X100K | X1M | X10M |
|-----|---------|---------|---------|---------|---------|---------|---------|---------|
| 1.0 | 5011333 | 5011295 | 5011274 | 5011197 | 5011272 | 5011207 | 5011320 | 5011332 |
| 1.2 | | 5011296 | 5011299 | 5011273 | 5011310 | 5011195 | 5011321 | |
| 1.5 | | 5011203 | 5011205 | 5011306 | 5011189 | 5011198 | 5011322 | |
| 1.8 | | 5011297 | 5011300 | 5011286 | 5011311 | 5011196 | 5011323 | |
| 2.2 | 5011282 | 5011192 | 5011194 | 5011307 | 5011312 | 5011208 | 5011324 | |
| 2.7 | 5011283 | 5011275 | 5011301 | 5011183 | 5011271 | 5011316 | 5011325 | |
| 3.0 | | | | 5011520 | | | | |
| 3.3 | 5011289 | 5011202 | 5011188 | 5011184 | 5011313 | 5011317 | 5011326 | |
| 3.9 | 5011290 | 5011298 | 5011302 | 5011308 | 5011314 | 5011318 | | |
| 4.7 | 5011291 | 5011191 | 5011303 | 5011193 | 5011284 | 5011206 | | |
| 5.1 | | | | | | 5011436 | | |
| 5.6 | 5011292 | 5011276 | 5011304 | 5011309 | 5011199 | 5011288 | | |
| 6.8 | 5011293 | 5011190 | 5011305 | 5011186 | 5011200 | 5011319 | | |
| 8.2 | 5011294 | 5011185 | 5011187 | 5011285 | 5011315 | 5011201 | | |

Resistors 5% 1/2 W

| | X1 | X10 | X100 | X1K | X10K | X100K | X1M | X10M |
|-----|---------|---------|---------|---------|---------|---------|---------|---------|
| 1.0 | | 5011000 | 5011013 | 5011028 | 5011044 | 5010313 | 5011069 | 5011083 |
| 1.2 | 5011406 | 5011001 | 5011014 | 5011030 | 5011045 | 5011058 | 5010421 | |
| 1.5 | 5010727 | 5011002 | 5011015 | 5011031 | 5011046 | 5011059 | 5011071 | |
| 1.8 | 5010857 | 5010787 | 5011016 | 5011033 | 5011047 | | 5011072 | |
| 2.2 | 5011335 | 5010708 | 5010815 | 5011034 | 5011048 | 5011061 | 5011074 | |
| 2.7 | | 5010803 | 5011018 | 5010055 | 5011049 | 5011062 | 5011075 | |
| 3.3 | 5010255 | 5011007 | 5011019 | 5011037 | | 5011063 | 5010381 | |
| 3.9 | | 5010782 | 5011021 | 5010700 | 5011051 | | 5010392 | |
| 4.7 | 5010765 | 5011009 | 5011022 | 5010035 | 5010036 | 5011065 | 5011078 | |
| 5.6 | | 5011010 | 5011023 | 5011041 | | 5011066 | 5011079 | |
| 6.8 | 5010874 | 5011011 | 5011024 | 5011042 | 5010810 | 5011067 | 5011080 | |
| 8.2 | | 5011012 | 5011026 | 5011043 | 5010038 | 5011068 | 5011081 | |

Resistors 5% 1/4 W

| | X1 | X10 | X100 | X1K | X10K | X100K | X1M | X10M |
|-----|---------|---------|---------|---------|---------|---------|---------|---------|
| 1.0 | 5010592 | 5010506 | 5010065 | 5010040 | 5010059 | 5010049 | 5010054 | 5010638 |
| 1.2 | | 5010595 | 5010128 | 5010153 | 5010046 | 5010047 | 5010665 | |
| 1.5 | 5011348 | 5010468 | 5010057 | 5010247 | 5010053 | 5010063 | 5010093 | |
| 1.8 | | 5010822 | 5010362 | 5010066 | 5010135 | 5010072 | 5010791 | |
| 2.2 | 5010682 | 5010448 | 5010092 | 5010064 | 5010079 | 5010120 | 5010245 | |
| 2.7 | 5010925 | 5010403 | 5010000 | 5010298 | 5010141 | 5010083 | 5010431 | |
| 3.3 | | 5010253 | 5010044 | 5010076 | 5010075 | 5010117 | 5010848 | |
| 3.9 | 5011377 | 5010622 | 5010070 | 5010069 | 5010060 | 5010073 | 5010714 | |
| 4.7 | 5010888 | 5010411 | 5010058 | 5010048 | 5010045 | 5010077 | 5011513 | |
| 5.6 | 5010706 | 5010151 | 5010067 | 5010041 | 5010061 | 5010071 | 5010658 | |
| 6.8 | 5010904 | 5010039 | 5010144 | 5010052 | 5010062 | 5010074 | | |
| 8.2 | 5010880 | 5010056 | 5010068 | 5010154 | 5010091 | 5010505 | | |

Resistors 5% 1/8 W

| | X1 | X10 | X100 | X1K | X10K | X100K | X1M | X10M |
|-----|---------|---------|---------|---------|---------|---------|---------|---------|
| 1.0 | | 5011464 | 5011357 | 5010816 | 5010935 | 5011440 | 5011459 | 5020875 |
| 1.2 | | 5011351 | 5011084 | 5011442 | 5011338 | 5011341 | 5011175 | |
| 1.5 | | 5011463 | 5011443 | 5011178 | 5011364 | 5011398 | 5011460 | |
| 1.8 | | 5011350 | 5011361 | 5011344 | 5011468 | | | |
| 2.2 | 5011032 | 5011376 | 5010886 | 5011353 | 5010833 | 5011369 | 5011342 | |
| 2.7 | | 5011471 | 5011355 | 5011362 | 5011366 | 5011370 | 5011478 | |
| 3.3 | | | 5011337 | 5010827 | 5011346 | 5011371 | 5011462 | |
| 3.9 | | 5011438 | | 5011157 | 5011457 | 5011372 | 5020876 | |
| 4.7 | 5011363 | 5011038 | 5011441 | 5011363 | 5010937 | 5011343 | | |
| 5.6 | | 5011412 | 5011358 | 5010885 | 5011166 | 5011340 | | |
| 6.8 | | 5011356 | 5011336 | 5010839 | 5011367 | 5011458 | | |
| 8.2 | | 5011466 | 5011354 | 5011339 | 5011368 | 5011373 | | |

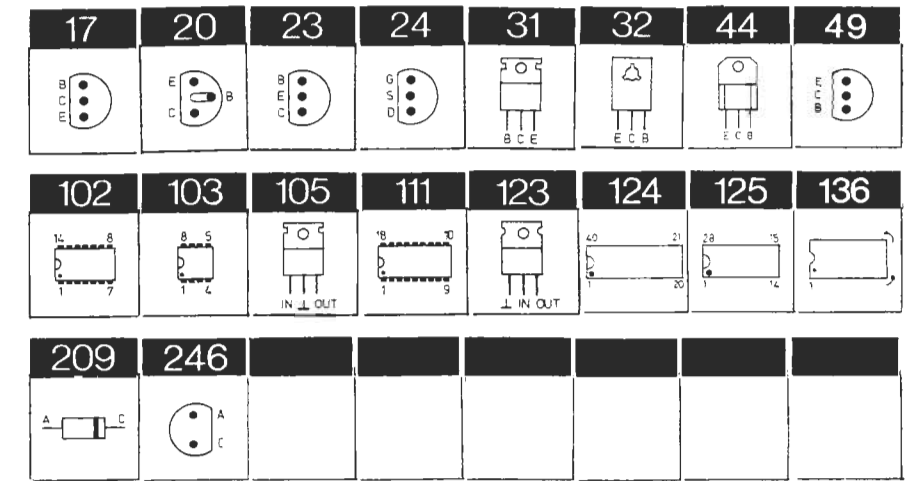

PCB 1, 8005217
Display

IC1Δ 8340467 124 MM 5450N

D1- 8300023 209 1N 4002 D3- 8330150 246 LED red
D2 D26

R1 5370068 22 kΩ 20% 0.1W

C2 4010105 1 nF 10% 63V C3 4130230 100 nF 20% 63V

S1 7400268 contact 1 pol

P11 7220580 Plug 2 pol

To P7 6275711 Wire w/sockets 7/7 pin

PCB 2, 8005218
Contact PCB

S101 7400268 contact 1 pol

To P11 6275712 Wire w/sockets 2/2 pin

PCB 5, 8005220
Decoder

IC1- 8340065 105 7805 PWR supl. +5 1A
IC2
IC3 8340931 123 7906 PWR supl. -6V 1A
IC4Δ 8340957 125 MAB 8461
IC5 8340157 102 LM 324
IC6Δ 8340914 136 MAB 8441 μC
IC7Δ 8340841 136 SAA 7210 Decoder
IC8Δ 8340927 111 UPD 41416 C
IC9Δ 8340855 136 SAA 7220 Digital filter
IC10Δ 8340913 136 TDA 1541 D/A Converter
IC11- 8340930 103 LM 833N DUAL OP-AMP
IC12

TR1 8320640 17 BC 636 TR27 8320152 20 BC 557B
TR2- 8320097 20 BC 547B TR28- 8320427 32 BD 437
TR3 TR29
TR5 8320542 44 BD 825-16 TR30- 8320097 20 BC 547B
TR6- 8320152 20 BC 557B TR32
TR7 TR33 8320152 20 BC 557B
TR10* 8320369 31 BD 534 TR34- 8320427 32 BD 437
TR11- 8320097 20 BC 547B TR35
TR12 TR38- 8320097 20 BC 547B
TR13- 8320152 20 BC 557B TR39
TR14 TR42 8320097 20 BC 547B
TR15 8320542 44 BD 825-16 TR43 8320152 20 BC 557B
TR16 8320152 20 BC 557B TR44 8320567 23 BF 450
TR20 8320097 20 BC 547B TR45 8320097 20 BC 547B
TR21 8320152 20 BC 557B TR48 8320097 20 BC 547B
TR24- 8320097 20 BC 547B TR49 8320152 20 BC 557B
TR26 TR101 8320722 24 2N 5638

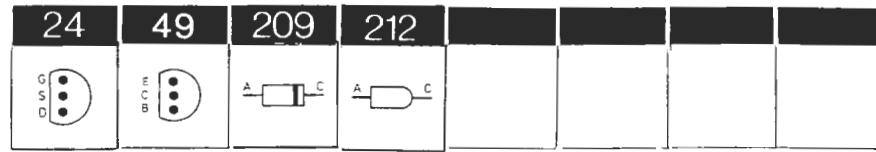

TR102- 8320660 **49** 2SC 2878A
 TR103
 TR201 8320722 **24** 2N 5638

TR202- 8320660 **49** 2SC 2878A
 TR203

| | |
|-------------------------------------|-------------------------------------|
| D1- 8300023 209 1N 4002 | D18 8300023 209 1N 4002 |
| D4 | D19 8300479 209 ZPD 79B 5.1V |
| D5 8300407 209 ZPD 12V | D20- 8300023 209 1N 4002 |
| D6 8300578 209 BZX 79 B9V1 | D21 |
| BZX 55 B9V1 | D22- 8300222 209 ZPD 2.7 V |
| D7 8300058 209 1N 4148 | D23 |
| D8 8300578 209 BZX 79 B9V1 | D25 8300407 209 ZPD 12 V |
| BZX 55 B9V1 | D26- 8300058 209 1N 4148 |
| D9 8300058 209 1N 4148 | D27 |
| D10 8300142 209 AA 143 | D31- 8300058 209 1N 4148 |
| D11- 8300294 212 1N 5401 | D35 |
| D14 | D40 8300058 209 1N 4148 |
| D15 8300023 209 1N 4002 | D42 8300596 209 6.2V 2% |
| D16- 8300579 209 BZX 79 B10V | D43 8300058 209 1N 4148 |
| D17 BZX 55 B10V | |

| | |
|--------------------------------|--------------------------------|
| R5 5020110 10 kΩ 1% 1/4W | R118 5011511 2.1 kΩ 1% 1/4W |
| R6 5020318 13 kΩ 1% 1/4W | R119 5011512 750 Ω 1% 1/4W |
| R11- 5020499 0.1 Ω 10% 0.4W | R126 5020956 68 Ω 5% 0.14W |
| R12 | R150 5030001 8 x 22 kΩ 5% 1/8W |
| R15 5020110 10 kΩ 1% 1/4W | R171 5011512 750Ω 1% 1/4W |
| R16 5020318 13 kΩ 1% 1/4W | R172 5021011 1.87 kΩ 1% 1/4W |
| R57 5020542 22.1 kΩ 1% 1/4W | R173 5020730 590 kΩ 1% 1/4W |
| R58 5020362 56.2 kΩ 1% 1/4W | R174 5011508 200 Ω 1% 1/4W |
| R60 5010862 7 x 4.7 kΩ 5% 1/8W | R212 5011507 374 Ω 1% 1/4W |
| R76 5020980 0.82 Ω 5% 1W | R214 5011508 200 Ω 1% 1/4W |
| R86 5020980 0.82 Ω 5% 1W | R215- 5011509 1.5 kΩ 1% 1/4W |
| R101 5020956 68 Ω 5% 0.14W | R216 |
| R112 5011507 374 Ω 1% 1/4W | R217 5011510 1 kΩ 1% 1/4W |
| R114 5011508 200 Ω 1% 1/4W | R218 5011511 2.1 kΩ 1% 1/4W |
| R115- 5011509 1.5 kΩ 1% 1/4W | R219 5011512 750 Ω 1% 1/4W |
| R116 | R226 5020956 68 Ω 5% 0.14W |
| R117 5011510 1 kΩ 1% 1/4W | |

| | |
|---------------------------------|---------------------------------|
| C1 4000340 22 nF -20+80% 40V | C48 4200617 47 μF 20% 10V |
| C3 4200102 470 μF -10+100% 40V | C49- 4000339 33 pF 5% 63V |
| C5 4130308 220 μF 10% 63V | C50 |
| C6 4200102 470 μF -10+100% 40V | C52 4200625 3.3 μF 20% 50V |
| C8 4130308 220 nF 10% 63V | C53 4000340 22 nF -20+80% 40V |
| C9 4200524 10 μF 20% 25V | C54 4200617 47 μF 20% 10V |
| C13 4200020 4700 μF 25V | C55 4100195 1.8 nF 5% 63V |
| C14 4130309 330 nF 10% 63V | C56 4000137 47 pF 5% 63V |
| C16 4200544 22 μF 20% 16V | C57 4200512 1 μF 20% 50V |
| C18 4200548 2200 μF -10+50% 25V | C58 4130240 47 nF 10% 63V |
| C19 4200517 2.2 μF 20% 50V | C59 4000340 22 nF -20+80% 40V |
| C20 4200512 1 μF 20% 50V | C60 4200617 47 μF 20% 10V |
| C25- 4010035 1 nF 10% 63V | C61 4200122 220 μF -10+100% 10V |
| C27 | C62 4000340 22 nF -20+80% 40V |
| C28- 4000339 33 pF 5% 63V | C65 4000340 22 nF -20+80% 40V |
| C29 | C66 4200617 47 μF 20% 10V |
| C30- 4010035 1 nF 10% 63V | C67- 4000137 47 pF 5% 63V |
| C31 | C68 |
| C32- 4000339 33 pF 5% 63V | C71- 4130308 220 nF 10% 63V |
| C33 | C77 |
| C34- 4010035 1 nF 10% 63V | C78 4000340 22 nF -20+80% 40V |
| C38 | C79 4200617 47 μF 20% 10V |
| C39 4200625 3.3 μF 20% 50V | C80 4010122 680 pF 10% 63V |
| C40 4200617 47 μF 20% 10V | C81- 4130308 220 nF 10% 63V |
| C41 4010107 22 nF -20+80% 40V | C87 |
| C42 4000204 100 pF 5% 63V | C88 4130240 47 nF 10% 63V |
| C43- 4010035 1nF 10% 63V | C89 4200688 47 μF 20% 50V |
| C45 | C90 4200617 47 μF 20% 10V |
| C46 4200625 3.3 μF 20% 50V | C91 4130240 47 nF 10% 63V |
| C47 4000340 22 nF -20+80% 40V | |

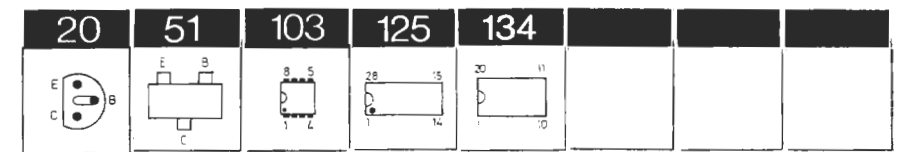

| | |
|----------------------------------|-------------------------------------|
| C92 4000340 22 nF -20+80% 40V | C110 4200403 100 μF -10+100% 25V |
| C93- 4130235 47 nF 20% 63V | C111 4200480 22 μF 20% 10V |
| C94 | C202 4200403 100 μF -10+100% 25V |
| C95- 4130210 47 nF 20% 63V | C203 4130267 18 nF 5% 63V |
| C98 | C204 4130270 68 nF 5% 63V |
| C99 4200512 1 μF 20% 50V | C205 4100278 8.2 nF 2.5% 63V |
| C102 4200403 100 μF -10+100% 25V | C206- 4100249 680 pF 2.5% 63V |
| C103 4130267 18 nF 5% 63V | C207 |
| C104 4130270 68 nF 5% 63V | C208 4100230 1.5 nF 2.5% 63V |
| C105 4100278 8.2 nF 2.5% 63V | C209 4100279 2 nF 2.5% 63V |
| C106- 4100249 680 pF 2.5% 63V | C210 4200403 100 μF 1/4 10+100% 25V |
| C107 | C211 4200480 22 μF 20% 10V |
| C108 4100230 1.5 nF 2.5% 63V | |
| C109 4100279 2 nF 2.5% 63V | |

L1- 8020565 2.2 μH
 L2

L3 8020639 100 μH

X1- 8090009 6.0 MHz
 X2

X3 8090058 11.2896 MHz

| | |
|-----------------------|------------------------|
| P2 7220574 Plug 3 pol | P6 7220582 Plug 14 pol |
| P3 7220312 Plug 2 pol | P7 7220471 Plug 7 pol |
| P4 7220313 Plug 3 pol | P8 7220312 Plug 2 pol |
| P5 7220583 Plug 5 pol | P10 7220584 Plug 8 pol |

C1 4010107 22 nF -20-80% 40V

To P3 6275715 Wire w/sockets 2/2 pin

To P2 6275744 Wire w/sokets 3/3 pin

PE201 8330196 Optocoupler

P1 7220584 Plug 8 pol

TF1 6609029 Thermal fuse 130° C

6275755 Audio wire bundle

| | |
|----------------------------|---------------------------|
| C1- 4010103 2.2 nF 10% 63V | C3 4010128 470 pF 10% 63V |
| C2 | |

7210384 Phono Socket (female)

7210600 DIN socket (female) 7 pol

P12- 7210614 Socket 14 pol.
 P13

| | |
|---------------------------------------|-------------------------------------|
| IC6101 8340991 125 TDA 5708 C3 | IC6103 8340993 103 NJM 4560D |
| IC6102 8340992 134 TDA 5709 | IC6104 8340683 103 L 272BH |

TR6108 8320721 **020** BC 338-16
 TR6109 8320615 **051** BC 848B

TR6112 8320616 **051** BC 858B

PCB 6, 8005221
 Motor

PCB 7, 8005219
 Optocoupler

PCB 8, 8005169
 Mains Transformer

PCB 9, 8005223
 Socket panel

PCB 10, 8005223
 Din socket

PCB 11, 8005222
 PCB Flex Print

PCB 30, 8005204
 Servo

| | | | | | | |
|---|--|--|--|--|--|--|
| 209 | | | | | | |
|  | | | | | | |

| | | | | | | | |
|--------|---------|------------|---------|--------|---------|------------|------------|
| D6107 | 8300058 | 209 | 1N 4148 | D6118- | 8300570 | 209 | HZ 7C2 7V5 |
| D6110- | 8300058 | 209 | 1N 4148 | D6119 | | | |
| D6111 | | | | | | | |

| | | | | | | | | | |
|--------|---------|----------------|-----|------|--------|---------|----------------|----|------|
| R3101 | 5020966 | 12 Ω | 5% | 1/8W | R3151 | 5011254 | 82 k Ω | 2% | 1/8W |
| R3102 | 5011234 | 4.7 k Ω | 2% | 1/8W | R3152 | 5011314 | 39 k Ω | 5% | 1/8W |
| R3103 | 5011256 | 100 k Ω | 2% | 1/8W | R3154 | 5011491 | 39 k Ω | 2% | 1/8W |
| R3104 | 5020967 | 18 Ω | 5% | 1/8W | R3155 | 5011241 | 10 k Ω | 2% | 1/8W |
| R3105 | 5011218 | 100 Ω | 2% | 1/8W | R3156- | 5011245 | 22 k Ω | 2% | 1/8W |
| R3106 | 5370355 | 1 k Ω | 20% | | R3157 | | | | |
| R3107- | 5020965 | 4.7 Ω | 2% | 1/8W | R3158 | 5011233 | 39 k Ω | 2% | 1/8W |
| R3108 | | | | | R3159 | 5010547 | 18 k Ω | 2% | 1/4W |
| R3109 | 5011244 | 18 k Ω | 2% | 1/8W | R3160 | 5020971 | 4.7 Ω | 1% | 1/4W |
| R3110 | 5011490 | 12 k Ω | 2% | 1/8W | R3161 | 5011490 | 12 k Ω | 2% | 1/8W |
| R3111 | 5011230 | 2.2 k Ω | 2% | 1/8W | R3162 | 5011254 | 82 k Ω | 2% | 1/8W |
| R3112 | 5011267 | 1 m Ω | 2% | 1/8W | R3163 | 5010056 | 82 Ω | 5% | 1/4W |
| R3113 | 5011218 | 100 Ω | 2% | 1/8W | R3166 | 5011250 | 47 k Ω | 2% | 1/8W |
| R3114 | 5011238 | 6.8 k Ω | 2% | 1/8W | R3167 | 5011490 | 12 k Ω | 2% | 1/8W |
| R3115 | 5011319 | 680 k Ω | 5% | 1/8W | R3191 | 5011241 | 10 k Ω | 2% | 1/8W |
| R3116 | 5011218 | 100 Ω | 2% | 1/8W | R3192- | 5011245 | 22 k Ω | 2% | 1/8W |
| R3135 | 5011586 | 11 k Ω | 2% | 1/8W | R3193 | | | | |
| R3136 | 5011259 | 150 k Ω | 2% | 1/8W | R3201 | 5011254 | 82 k Ω | 2% | 1/8W |
| R3137 | 5011257 | 120 k Ω | 2% | 1/8W | R3202 | 5011250 | 47 k Ω | 2% | 1/8W |
| R3138 | 5020964 | 1.0 Ω | 2% | 1/8W | R3204 | 5011238 | 6.8 k Ω | 2% | 1/8W |
| R3139 | 5011254 | 82 k Ω | 2% | 1/8W | R3205 | 5011254 | 82 k Ω | 2% | 1/8W |
| R3140 | 5020964 | 1.0 Ω | 2% | 1/3W | R3206 | 5011255 | 91 k Ω | 2% | 1/8W |
| R3141 | 5011587 | 160 k Ω | 2% | | R3207 | 5020263 | 100 k Ω | 1% | 1/4W |
| R3143 | 5011269 | 47 Ω | 2% | 1/8W | R3208 | 5020969 | 47 k Ω | 1% | 1/4W |
| R3144 | 5011255 | 91 k Ω | 2% | 1/8W | R3209 | 5011234 | 4.7 k Ω | 2% | 1/8W |
| R3145 | 5011318 | 390 k Ω | 5% | 1/8W | R3210- | 5020964 | 1.0 Ω | 2% | 1/3W |
| R3146 | 5370254 | 22 k Ω | 20% | 0.1W | R3211 | | | | |
| R3150 | 5011491 | 39 k Ω | 2% | 1/8W | | | | | |

| | | | | | | | | | |
|--------|---------|--------|---------|-----|--------|---------|--------|------|------|
| C2101 | 4000255 | 22 nF | 10% | 50V | C2139 | 4000255 | 22 nF | 10% | 50V |
| C2102 | 4000249 | 470 pF | 5% | 50V | C2140 | 4200745 | 220 mF | 16V | |
| C2103 | 4200414 | 33 mF | -10+50% | 16V | C2141 | 4130245 | 220 nF | 5% | 63V |
| C2104 | 4200482 | 47 mF | 20% | 10V | C2142 | 4000256 | 100 nF | 10% | 50V |
| C2105- | 4000255 | 22 nF | 10% | 50V | C2150- | 4130424 | 3.6 nF | 160V | 1% |
| C2106 | | | | | C2151 | | | | |
| C2107 | 4200482 | 47 mF | 20% | 10V | C2152 | 4130206 | 220 nF | 10% | 100V |
| C2108 | 4000254 | 10 nF | 10% | 50V | C2153 | 4130314 | 180 nF | 10% | 63V |
| C2109 | 4130379 | 270 nF | 5% | 63V | C2154 | 4130206 | 220 nF | 10% | 100V |
| C2110 | 4000253 | 5.6 nF | 10% | 50V | C2155 | 4130405 | 470 nF | 10% | 50V |
| C2111 | 4130405 | 470 nF | 10% | 50V | C2156 | 4130338 | 6.8 nF | 5% | 100V |
| C2112 | 4130406 | 150 nF | 5% | 50V | C2159 | 4130293 | 470 nF | 10% | 63V |
| C2113 | 4000248 | 100 pF | 5% | 50V | C2160 | 4010173 | 4.7 nF | 10% | 50V |
| C2114 | 4000233 | 220 pF | 5% | 50V | C2200 | 4010173 | 4.7 nF | 10% | 50V |
| C2117 | 4010173 | 4.7 nF | 10% | 50V | C2202 | 4130405 | 470 nF | 10% | 50V |
| C2135 | 4130370 | 4.7 nF | 5% | | C2203 | 4130221 | 18 nF | 5% | 63V |
| C2136 | 4130405 | 470 nF | 10% | 50V | C2204- | 4000255 | 22 nF | 10% | 50V |
| C2137 | 4000255 | 22 nF | 10% | 50V | C2205 | | | | |
| C2138 | 4200745 | 220 mF | 16V | | | | | | |

| | | | | | |
|-----|---------|---------------|-----|---------|-------------|
| P31 | 7210614 | Socket 14 pol | P34 | 7220657 | Plug 14 pol |
| P33 | 7220652 | Plug 5 pol | P36 | 7220651 | Plug 4 pol |

| | | | | | |
|-------|---------|--------------------------|-------|---------|----------------------------|
| To P5 | 6275746 | Wire w/sokets 5/5 pin | To P6 | 6275745 | Wire w/sokets 14/14 pin |
|-------|---------|--------------------------|-------|---------|----------------------------|

Δ betyder at statisk elektricitet kan ødelægge komponenten.
 Δ indicates that static electricity may destroy the component.
 Δ bedeutet, daß statische Elektrizität die Komponente zerstören kann.
 Δ signifie que électricité statique peut détruire le composant.

* Speciel udvalgt eller bearbejdet eksemplar.
 * Specially selected or adapted sample.
 * Speziell ausgewähltes und bearbeitets Exemplar.
 * Exempleire, spécialement sélectionné et façonné.

MECHANICAL PARTSLIST

Chassis

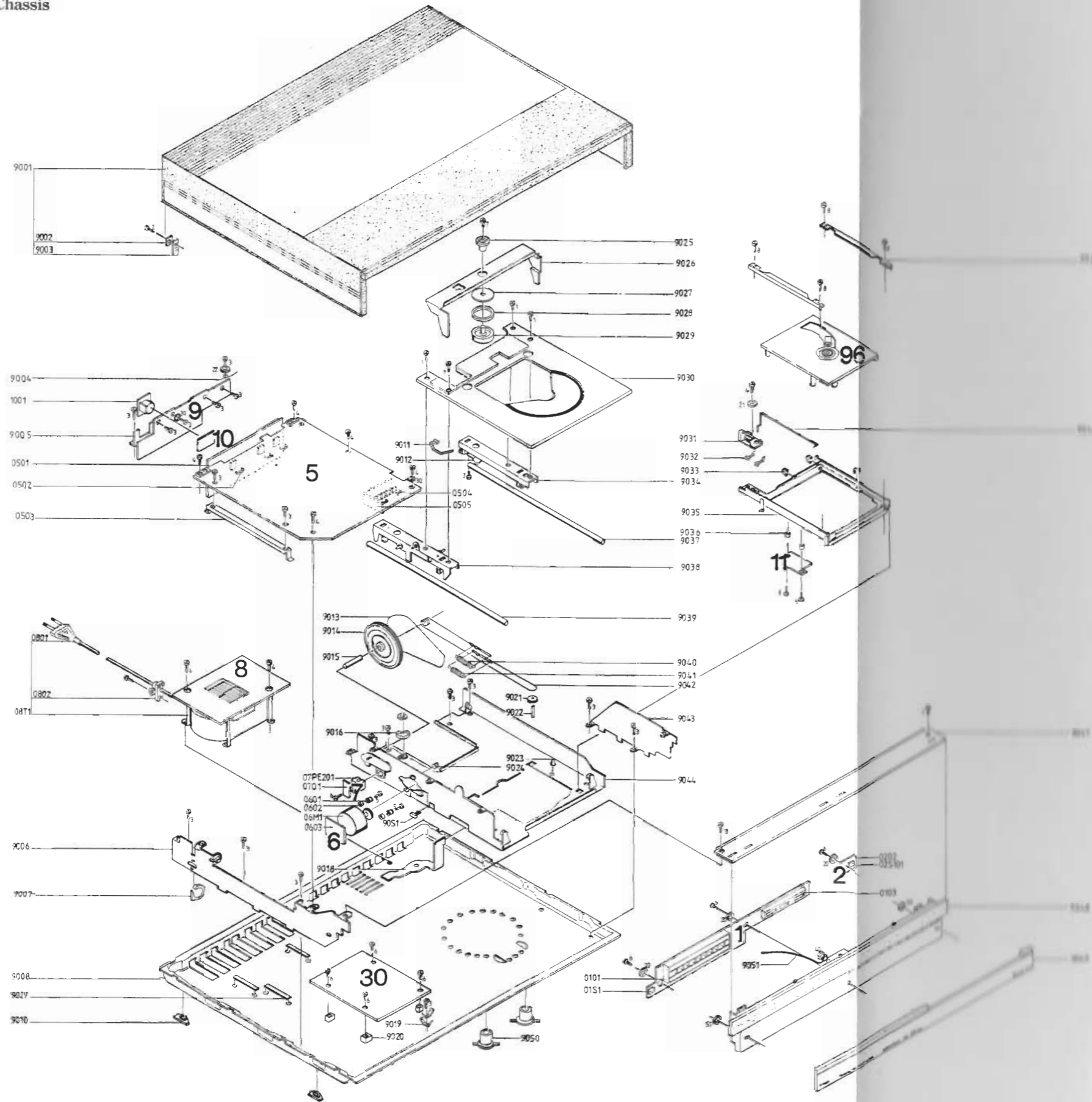

- 01Modul 8005217 Display
- 0101 3131247 Housing Bargraph
- 3370152 Difus Tape Bargraph
- 0181 7400268 Contact
- 0103 3131252 Housing Display
- 3370155 Difus Tape display

- 05Modul 8005220 Decoder
- 0501 3358228 Heat sink
- 0502 2816195 Spring (transistor)
- 0503 2566047 Guide rail
- 0504 2816000 Spring (transistor)
- 0505 3358202 Heat sink

- 09Modul 8005223 PCB socket panel

- 10Modul 8005223 PCB Din socket
- 1001 7210600 Plug 7 pol.

- 11Modul 8005222 Print f. flex print

- 30Modul 8005204 Servo

- 96Modul 8420138 Mechanism

- 02S101 7400268 Contact
- 0201 8005218 PCB
- 06M1 8400169 Motor
- 0601 2938253 Bushing
- 0602 2930074 Bushing
- 0603 8005221 PCB

- 08T1 8005169 PCB 8 w/Transformer
- 0802 3152472 Holder for mains cord
- 0801 6271102 Mains cord (EU)
- 6270251 Mains cord (US)
- 6271119 Mains cord (J)
- 6270297 Mains cord (AUS)

- 07PE201 8330196 Optocoupler
- 0701 8005219 PCB

- 90S1 7400322 Switch

- 9001 3414032 Cabinet
- 9002 3034073 Bracket
- 9003 2391059 Bracket
- 9004 2816243 Spring
- 9005 7219065 Bracket f. socket panel
- 9006 3112331 Chassis (for PCB)
- 9007 3152366 Wire holder
- 9008 3454445 Bottom
- 9009 3132101 Wire holder
- 9010 3035119 Slide shoe
- 9011 2816239 Leaf spring
- 9012 2816240 Spring for trolley shoe
- 9013 2732083 Belt
- 9014 2724076 Tacho wheel
- 9015 2830134 Shaft
- 9016 3010029 Stop block rubber
- 9018 6141178 Flex PCB
- 9019 7509176 Solder tag
- 9020 2576109 Spacer
- 9021 2724069 Cord pulley
- 9022 2830133 Shaft
- 9023 3020007 Stop blok
- 9024 2938253 Rubber bushing
- 9025 2905120 Seat f. CD holder
- 9026 2510158 Bracket f. CD holder
- 9027 2622412 Washer f. CD holder
- 9028 3356048 Magnet
- 9029 3152536 Holder f. CD
- 9030 3454479 CD tray
- 9031 2751020 Driving plate
- 9032 2851214 Arm
- 9033 3152118 Wire holder
- 9034 3150069 Holder
- 9035 3114289 Chassis f. CD mech.
- 9036 2930099 Bushing
- 9037 2830128 Shaft bar short
- 9038 3150068 Holder
- 9039 2830129 Shaft bar long
- 9040 2810216 Spring
- 9041 2810215 Spring
- 9042 3955041 Wire
- 9043 2542698 Angle f. front
- 9044 3112334 Chassis
- 9045 2542699 Angle
- 9046 2850141 Arm
- 9047 2560218 Bracket f. front
- 9048 3114273 Chassis front
- 9049 2568978 Front panel
- 9050 3152560 Transport screw
- 9051 6032258 Wire

Parts not shown

- 7500157 Crimp f. wire
- 3391251 Outer carton
- 3391997 Insert for packing
- 3397571 Foam packing, set
- 3946048 Foil
- 6270213 Signal cable 7 pol.
- 3629107 Blade T6 short
- 3629037 Blade T8 short
- 3629102 Blade T10 long
- 3629038 Blade T10 short
- 3629103 Blade T20 short
- 3629109 Screw driver T6
- 3629108 Screw driver T8
- 3629047 Screw driver T10

- 3629104 Screw driver T20
- 3634030 Glass disc
- 3634031 Test disc 5 and 5A
- 3634032 Magnet ring
- 3505479 Owner's Manual DK
- 3505480 Owner's Manual S
- 3505481 Owner's Manual SF
- 3505482 Owner's Manual GB
- 3505483 Owner's Manual D
- 3505484 Owner's Manual NL
- 3505485 Owner's Manual F
- 3505486 Owner's Manual I
- 3505487 Owner's Manual USA

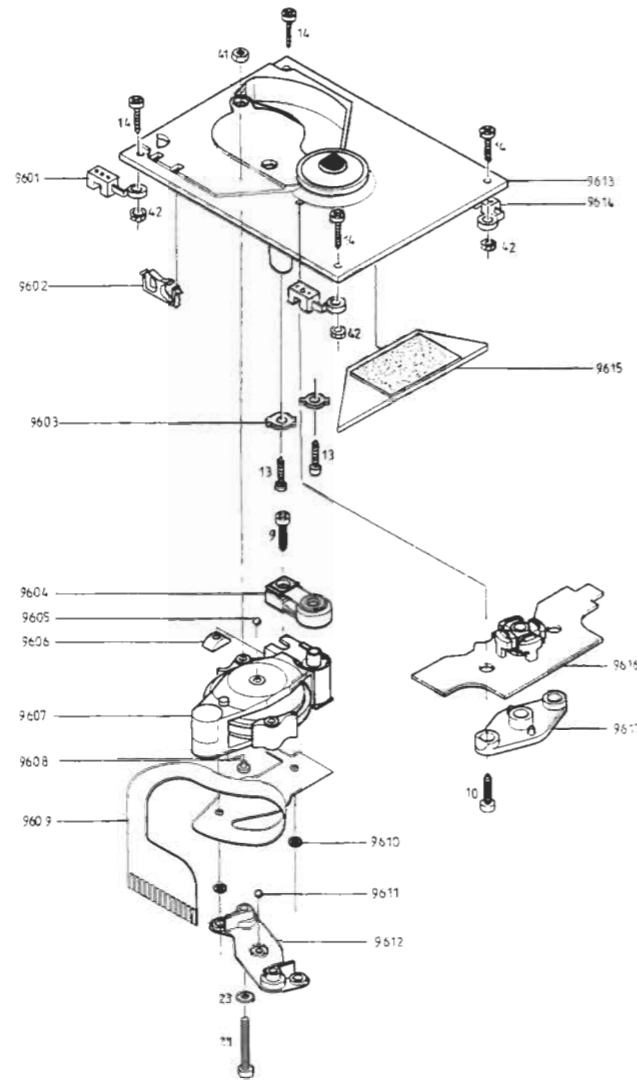

- | | | | | | |
|---------|---------|--------------------|-----------------------------|---------|----------------|
| 9601 | 3333016 | Rubber holders | 9610 | 2622426 | Washer f. foil |
| 9602 | 3152593 | Clamp f. flexprint | 9611 | 2917024 | Ball |
| 9603 | 3034077 | Transport screw | 9612 | 2905116 | Pivot plate |
| □ 9604 | 8330210 | Focusunit | 9614 | 3333015 | Rubber holders |
| 9605 | 2917024 | Ball | 9615 | 3342046 | Weighing block |
| 9606 | 2389077 | Spec. nut | The disc motor system pos. | | |
| ○ 9607△ | 3131296 | Rafoc | no. 9613, 9616 and 9617 are | | |
| 9608 | 3010031 | Rubber stop | one unit, part no. 3114292 | | |
| 9609 | 6141131 | Flex print | | | |

- Replacement of 9604 see page 5-5, 5-9
- Replacement of 9607 see page 5-4, 5-5, 5-12

Screws, washers, etc.

- | | | | | | |
|----|---------|--------------------|----|---------|-----------------------|
| 1 | 2038097 | Screw M3x6 mm | 13 | 2013145 | Screw 3 x 12 mm |
| 2 | 2043016 | Screw AM 4x10 mm | 14 | 2034064 | Screw 2 x 10 mm |
| 3 | 2038096 | Screw M3x5 mm | 20 | 2622052 | Washer 3.2x3x1 mm |
| 4 | 2038098 | Screw M3x8 mm | 21 | 2622348 | Washer 2.3 mm |
| 5 | 2036016 | Screw AM 2.6x6 mm | 22 | 2622321 | Washer 3.2 mm |
| 6 | 2013136 | Screw 3x6 mm | 23 | 2624013 | Washer 3 mm |
| 7 | 2013137 | Screw 3x10 mm | 30 | 2625002 | Tooth lock washer 3.2 |
| 8 | 2038103 | Screw AM 3x12 mm | 40 | 2380011 | Nut M3 |
| 9 | 2011038 | Screw 2.2x10 mm | 41 | 2380012 | Nut M3 |
| 10 | 2013149 | Screw 2.9x16 mm | 42 | 2380147 | Nut M3 |
| 11 | 2038120 | Screw 3x25 mm | 50 | 2390001 | Spring washer 2.3 DIN |
| 12 | 2013094 | Screw M 2.9x6.5 mm | 51 | 2390103 | Spring washer Ø2x0.25 |

MEKANISKE JUSTERINGER

Højde på løbeværket

Justeringen foretages med de 4 skruer i gummidæmperne i hjørnerne på løbeværket. De 2 bageste skruer kan justeres gennem hullerne F i pladeskuffen når skuffen er inde, og de 2 forreste når skuffen er næsten ude. Der bør justeres lige meget og i samme retning på alle 4 skruer. For at nå de 2 forreste skruer skal den lange vinkel over fronten tages af, og for at lette justeringen vippes fronten ned.

Læg CD-plade i og tryk pladeskuffen ind.

Juster de 4 nævnte skruer til CD-pladens underkant er $0,3 \text{ mm} \pm 0,3 \text{ mm}$ over pladeskuffens overkant når pladeskuffen er inde.

Centrering af løbeværk

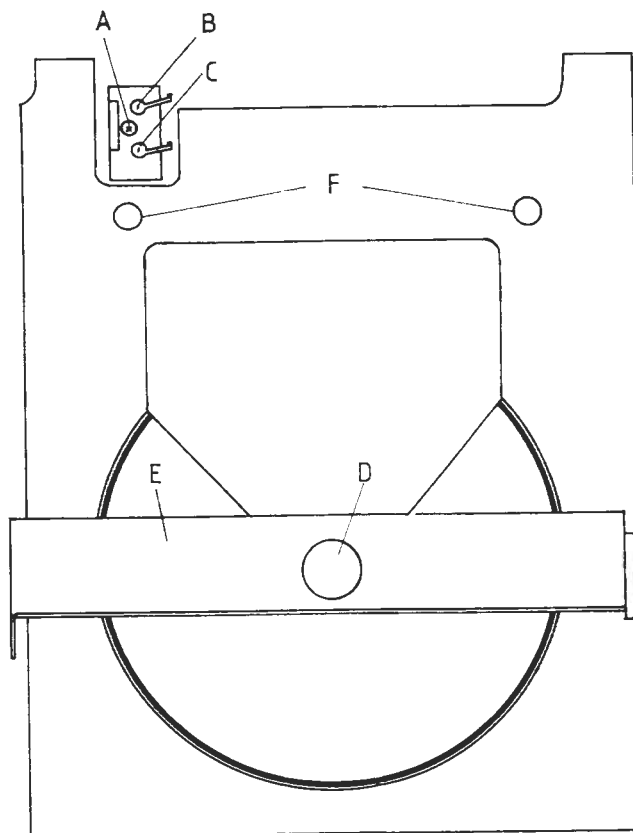

Læg en CD-plade i og tryk pladeskuffen ind.

Skruen A løsnes.

Ekscentrik B justeres til CD pladen er midt i fordybningen i pladeskuffen.

Skruen A spændes.

MECHANICAL ADJUSTMENTS

Height of drive mechanism

Make the adjustment with the 4 screws in the rubber dampers at the corners of the drive mechanism. The 2 rearmost screws may be adjusted through the holes F in the disc drawer when the drawer is in, and the 2 frontmost screws may be adjusted when the drawer is almost out. All 4 screws should be adjusted identically. In order to reach the 2 frontmost screws, the long bracket at the top of the front should be removed, and the front should be tilted down to facilitate the adjustment.

Insert a CD and push in the disc drawer.

Adjust the 4 screws mentioned until the lower edge of the CD is $0.3 \text{ mm} \pm 0.3 \text{ mm}$ above the upper edge of the disc drawer when the disc drawer is in.

Centring of drive mechanism

Load a CD and push the disc drawer in.

Loosen screw A.

Using eccentric B, adjust until the CD is at the centre of the depression in the disc drawer.

Tighten screw A.

Centrering af vinkel for pladeholdermagnet
Pladeskuffen trykkes ind.

Skruen A skal være løsnet.

Ekscentrik C justeres til pladeholdermagneten D ligger midt i hullet i vinklen E.

Skruen A spændes.

Højde af vinkel for pladeholdermagnet

Læg en CD plade og tryk pladeskuffen ind.

Right Hand Side

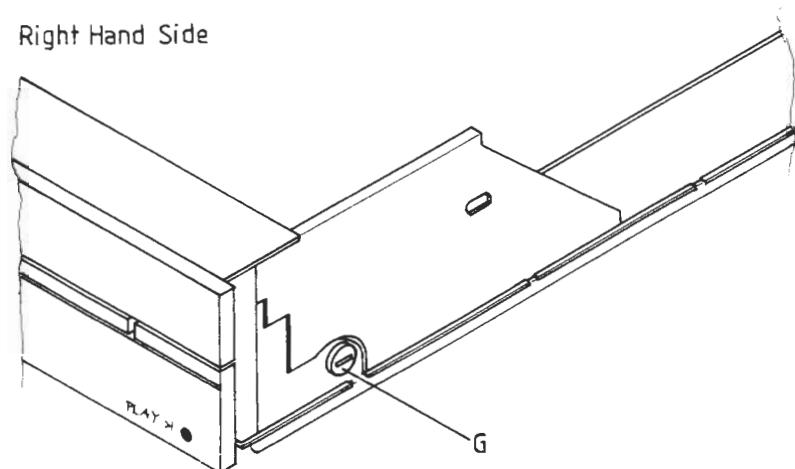

Skruen G justeres til højden af vinklen E ligger midt i frigangen H på plademagneten D.

Kontroller at pladeholdermagneten ikke går imod metalpladen, som er limet på den bageste del af pladeskuffen, når skuffen trækkes ud og ind.

Stop position for pladeskuffe

Pladeskuffen skal være trykket helt ind.

Medens skuffen trykkes ind mod stop, justeres unbra-koskrue (5 mm) under bunden, indtil skuffeforkanten flugter med fronten på apparatet.

Højde pladeskuffe forkant

Pladeskuffen trykkes ind.

De 2 skrue under den forreste del af bunden justeres til overkanten af pladeskuffen flugter med overkanten af aluminiumslisten på fronten.

Centring of bracket for disc clamping magnet
Push in the disc drawer.

Screw A must be loosened.

Using eccentric C, adjust until the disc clamping magnet D is at the centre of the hole in the bracket E.

Tighten screw A.

Height of bracket for disc clamping magnet

Insert a CD and push in the disc drawer.

By means of screw G, adjust until the height of the bracket E is at the centre of the clearance H between the bracket and the disc magnet D.

Make sure that the disc clamping magnet does not hit the metal sheet which is glued onto the rearmost part of the disc drawer when the drawer is pulled out and pushed in.

Stop position for disc drawer

The disc drawer must be fully depressed.

While the drawer is pressed against stop, adjust the allen screw (5 mm) in the bottom until the front edge of the drawer is flush with the front of the set.

Height of front edge of disc drawer

Push in the disc drawer.

By means of the 2 screws under the front part of the bottom, adjust until the upper edge of the disc drawer is flush with the upper edge of the aluminium strip on the front.

ELEKTRISKE JUSTERINGER

Lysintensitet (Brightness)

ELECTRIC ADJUSTMENTS

Brightness

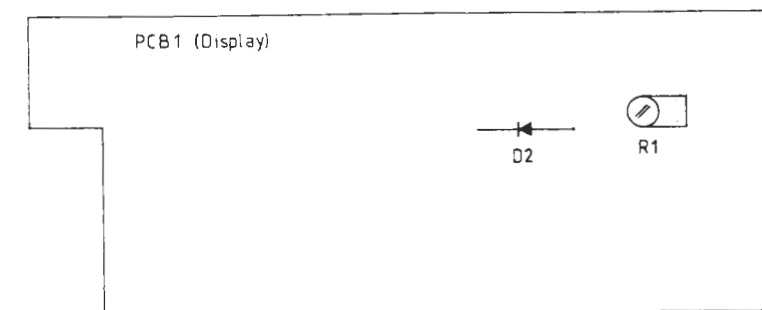

ID2 loddes fri og løftes i den ene ende.

Milliamperemeter sættes ind i serie med ID2.

Ilæg en CD plade med mere end 15 numre.

Tryk PLAY.

1R1 justeres til der måles 153 mA \pm 5 mA.

+5V strømfor-syning

Unsolder ID2 and elevate it at one end.

Connect a milliammeter in series with ID2.

Insert a CD with more than 15 tracks.

Press PLAY.

Adjust 1R1 until a measurement of 153mA \pm 5mA is obtained.

+5V power supply

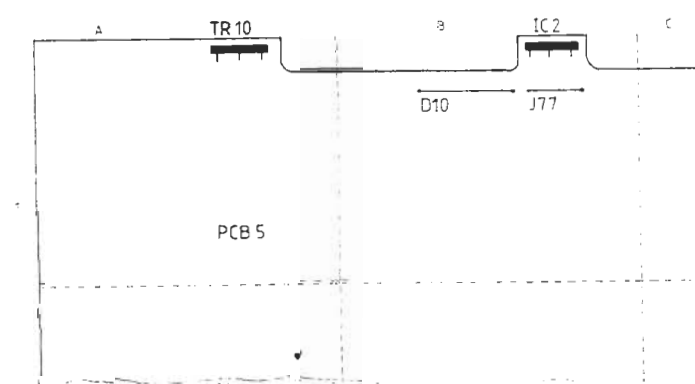

Ilæg en CD plade og tryk PLAY.

Mål DC spændingen fra ben 20 til ben 40 på 5IC7. (SAA 7210).

NB! Der skal måles direkte på IC'en.

5D10 skal være kortsluttet (5J77).

Hvis den målte spænding er lavere end 4,85 V skal 5J77 afbrydes.

Load a CD and press PLAY.

Measure the DC voltage from pin 20 to pin 40 of 5IC7 (SAA 7210).

NOTE: The measurement must be made on the IC directly.

5D10 must be short-circuited (5J77).

If the measured voltage is less than 4.85V, 5J77 has to be disconnected.

KONTROL, REPARATION OG JUSTERING AF CD LØBEVÆRK

For at forhindre metalsplinter i at komme ned i løbeværket, er det nødvendigt at reparationspladsen er helt ren.

PHOTODIODERNE OG LASEREN ER MERE FØLSOMME OVERFOR STATISK EL END MOS IC'er. UFORSIGTIG BEHANDLING UNDER SERVICE KAN REDUCERE LEVETIDEN DRASTISK. DERFOR SKAL DET SIKRES AT ARBEJDSPLADSEN ER BESKYTTET MOD STATISK EL.

Ved reparation af løbeværket skal der udvises forsigtighed for at undgå beskadigelse af focus bladfjederen.

Servicering af RAFOC enheden (= Radial og Focus enhed, pos. nr. 9607, se exploded view).

Tag CD løbeværket ud af apparatet.

RAFOC enheden kan tages ud ved at løsne de 2 stk. 2,9 x 16 mm fastspændingsskruer.

Bemærk: Når de nævnte skruer løsnes, er de 2 møtrikker på oversiden af løbeværket løse. Armlejet pos. 9612 trækkes ud, og RAFOC enheden med det fleksible print kan nu tages ud.

BEMÆRK! Ved montering af RAFOC enheden, er det meget vigtigt, at det fleksible print ligger helt op mod topchassiset på CD løbeværket, der hvor holder pos. 9602 skal holde printet fast. For at forhindre at RAFOC enheden kan gå imod det fleksible print, kan det være nødvendigt at lime printet fast mod topchassiset med hurtig tørrende lim. Dette skal dog gøres meget forsigtigt.

Hvis laser eller monitor diode er defekt, er det nødvendigt at skifte RAFOC enheden pos. 9607. Efter montering af RAFOC enheden skal det sikres, at enheden kan bevæges helt frit gennem hele vandringsen.

Dette kan kontrolleres med en trykfjedermåler, som holdes imod magneten på fokusenheden. Friktionen skal være under 25 mN gennem enhedens hele vandring.

CHECK, REPAIR AND ADJUSTMENT OF THE CD MECHANISM

To prevent loose metal objects from getting in the CD mechanism, it will be necessary to see to a clean repair station.

THE PHOTODIODES AND THE LASER ARE MORE SENSITIVE TO ELECTROSTATIC DISCHARGES THAN MOS ICs. CARELESS HANDLING DURING SERVICING MAY REDUCE LIFE EXPECTATION DRASTICALLY. THEREFORE, CARE SHOULD BE TAKEN, THAT THE REPAIR STATION IS PROTECTED AGAINST STATIC ELECTRICITY.

When effecting repairs to, or making measurements on the CD mechanism, be careful not to damage the flat springs of the focusing unit.

Servicing the RAFOC unit (= Radial and Focusing unit, pos. 9607. See exploded view).

Take the CD mechanism out of the set.

The RAFOC unit can be removed after the two fixing screws 2.9 x 16 mm have been loosened.

Caution: when doing so, the two nuts M3 on the upper side of the CD mechanism come loose. Now the pivot plate pos. 9612 can be removed. After removing the clamping piece, pos. 9602 the RAFOC unit/flexible PCB assembly can be taken out.

ATTENTION: When mounting the RAFOC unit, see to it that the flexible PCB rest well against the mounting plate at the height of the clamping piece (pos. 9602). In some cases, after exchanging the RAFOC unit/flexible PCB assembly, it may be necessary to glue the flexible PCB with a fast-drying glue to prevent the RAFOC unit from rubbing against the flexible PCB.

The gluing should be done very carefully.

When the laser and/or the monitor diodes are defective, it will be necessary to replace the RAFOC unit, pos. 9607.

After mounting the RAFOC unit you should make sure that the arm runs clear over the entire disc diameter.

This can be checked by means of a spring-pressure gauge which is held against the magnet of the focusing unit. The friction of the arm, measured over the entire meter reading, may not be greater than 25 mN.

En hurtig kontrol af RAFOC enhedens frigang kan gøres i service position 1, hvor enheden kan bevæges gennem hele vandringsen med OPEN og PLAY tasterne. (Se reparationstips side 7.1). Efter montering af RAFOC enheden skal laserarmens vinkelindstilling kontrolleres. Playability efter montering af RAFOC enheden kan afprøves med testplade 5A.

Udskiftning af servo PCB30, RAFOC enhed pos. nr. 9607 eller focus enhed pos. nr. 9604

(Kun i apparater med 1 potentiometer på PCB30).

Ved udskiftning af en af de nævnte dele, skal følgende kontrolleres:

Tilslut DC voltmeter med + til 30P31 ben 13 og - til 30P31 ben 14 (stel).

Hvis der er monteret en 820 kohms modstand fra ben 8 på 30IC6104 til -6 Va, afmonteres denne.

CD løbeværket skal stå helt vandret.

Ilæg testplade 5A (bestillingsnr. 3634031). Sæt apparatet i serviceposition. (Kortslut servicestikket på PCB5 samtidig med at netstikket sættes i). Tryk derefter OPEN og PLAY samtidigt 3 gange.

Hvis spænding overstiger +165 mV monteres 820 kohms modstanden fra ben 8 på 30IC6104 til -6 Va.

Justering af Focus offset (er ikke muligt i de først producerede apparater).

Ilæg testplade 5A (bestillingsnr. 3634031).

Sæt apparatet i serviceposition 2 ved at kortslutte servicestikket på PCB5 samtidig med at netstikket sættes i.

Tryk derefter »OPEN« og »PLAY« samtidigt og 2 gange.

Hvis »2« i displayet bliver ved med at blinke, justeres 30R3146 til »2« lyser konstant.

Sæt apparatet i serviceposition 4 ved at trykke »OPEN« og »PLAY« samtidigt og 2 gange (»4« i displayet skal lyse, og pladen skal rotere).

Tilslut DC voltmeter over 30C2136.

Juster 30R3146 til der måles 400 mV ±40 mV.

A fast check of the clearance of the arm is possible in service position 1. The RAFOC unit can be moved across the diameter of the disc by operating the OPEN and PLAY keys. (See repair hints page 7.1). After mounting the RAFOC unit the angle setting of the laser arm should be checked. Playability after mounting the RAFOC unit can be checked using test disc 5A.

Replacing the servo PCB30, RAFOC unit pos. no. 9607 or focusing unit pos. no. 9604

(Only in a CD with a potentiometer on PCB30).

When replacing one of the mentioned parts, the following shall be checked:

Connect DC voltmeter with + to 30P31 pin 13 and - to 30P31 pin 14 (ground).

If a resistor of 820kohms is mounted from pin 8 of 30IC6104 to -6Va, this should be dismantled.

The CD mechanism must be placed completely horizontally.

Put test disc 5A (part no. 3634031) on the turntable. Put the player in service position. (Short circuit the service plug on PCB5 and plug into mains supply at the same time). Then press OPEN and PLAY simultaneously and 3 times.

If the voltage measured, exceeds +165 mV, the resistor of 820kohms shall be mounted from pin 8 of 30IC6104 to -6Va.

Adjustment of DC focus offset (not possible in the first productions of the unit).

Load test disc 5A (order no. 3634031).

Set unit to service position 2 by short-circuiting the service point on PCB5 while inserting the mains plug.

Then press "OPEN" and "PLAY" simultaneously twice.

If "2" on the display keeps flashing, adjust 30R3146 until "2" light constantly.

Set the unit to service position 4 by pressing "OPEN" and "PLAY" simultaneously twice. ("4" on the display should light and the disc rotate).

Connect DC voltmeter across 30R2136.

Adjust 30R3146 until the reading is 400 mV ±40 mV.

Kontrol af vinkel indstilling på laserarm

Vinkel indstillingen kan kontrolleres efter glasplade-metoden, som er forklaret i det efterfølgende.

Checking the angle setting

The angle setting can be checked with the glass-disc method which is explained below.

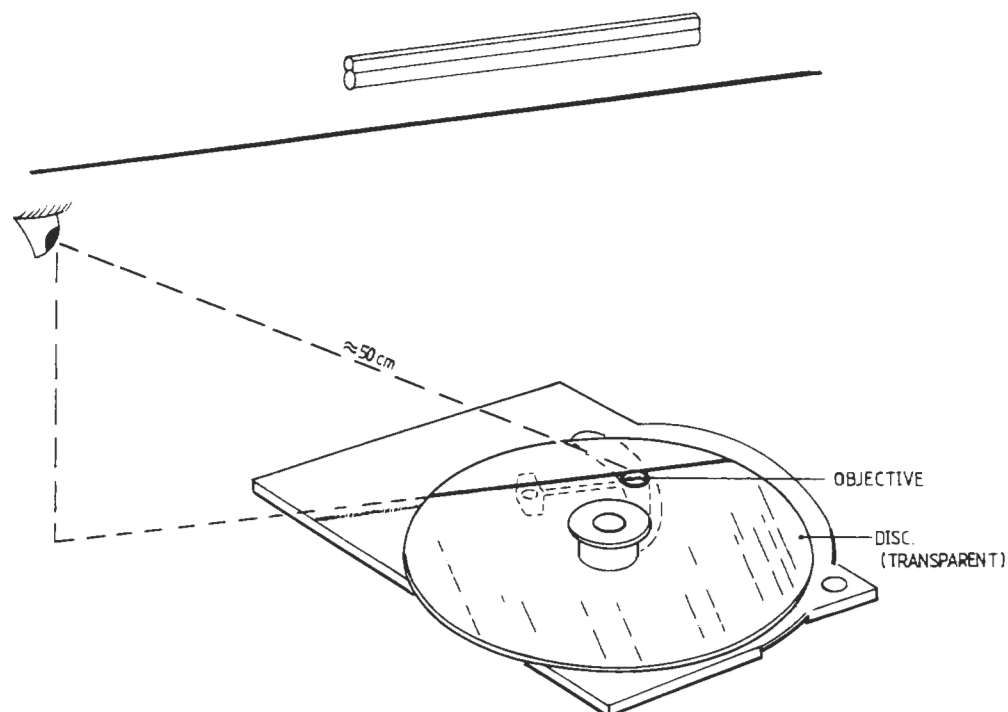

Læg glasplade (bestillingsnr. 3634030) på pladeholderen. Glaspladen skal hvile jævnt mod pladeholderen.

Put glass disc part no. 3634030 on the turntable. Make sure that the glass disc beds down well on the turntable.

Placer CD løbeværket under en lyskilde hvorunder der er en lige linie (f.eks. et lysstofrør med gitter). Afstanden mellem løbeværket og lyskilden skal være større end 1,5 m.

Place the CD mechanism under a light source, under which there is a straight line (e.g. under a fluorescent tube with grid). The distance between the CD mechanism and the light source should be more than 1.5 m.

Placer laserarmen midt i dens radiale vandring.

Set the arm to mid-position of its radial track.

Drej løbeværket indtil laserarmen er parallel med linien fra lyskilden.

Turn the mechanism until the arm is parallel to the line under the light source (see figure below).

Se i forlængelse af den reflekterede linie på henholdsvis glasplade og optik. Der må ikke være mere end 4 mm afstand mellem de 2 linier.

Look into the direction and in the extension of the line to the reflection there of on the glass disc and in the objective. These lines should not be apart more than 4 mm.

Placer CD løbeværket sådan at linien der reflekteres af optikken løber gennem optikkets centrum.

Place the CD mechanism so that the reflected line runs across the centre of the objective.

Hvis linien der reflekteres af glaspladen er indenfor optikkets overfalde, er vinkel indstillingen i orden.

When the line that is reflected by the glass disc stays within the surface of the objective, the angle setting is correct.

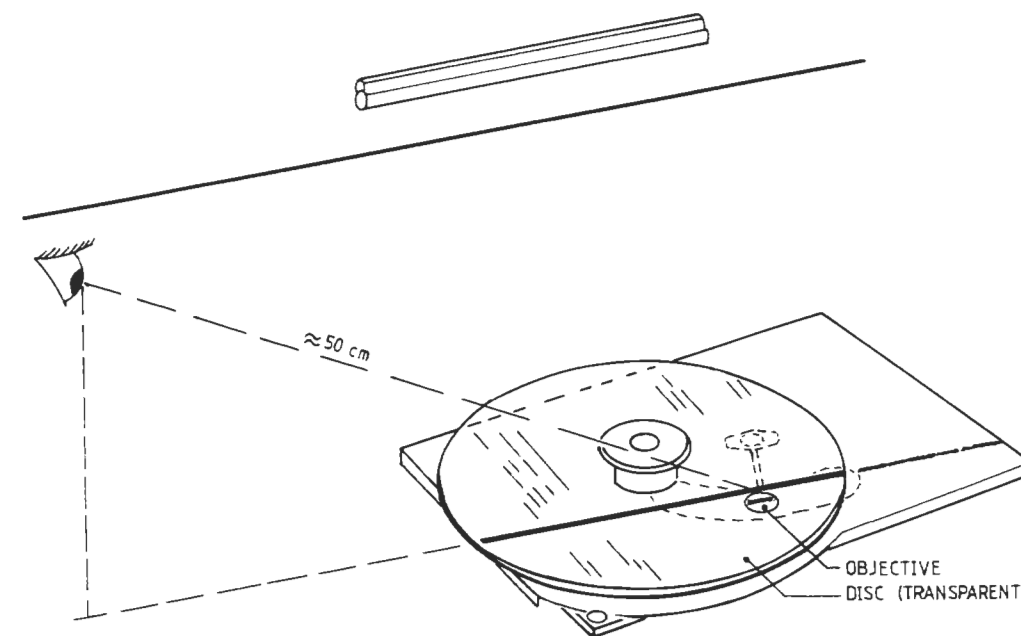

Drej CD løbeværket 90° i forhold til forrige position.

Turn the CD mechanism through 90° relative to the previous position.

Hold laserarmen i midterposition.

The arm must be kept in mid-position (see figure above).

Gentag ovenstående kontrol.

Repeat the previous check.

Justering af vinkel indstilling

Hvis kontrol af vinkel indstilling viser, at vinklen er udenfor tolerance, skal den *ikke* justeres til minimum afvigelse men blot indenfor tolerance.

Adjusting the angle setting

If a check on the angle setting shows that the angle falls outside the tolerance, the angle should *not* be adjusted for minimum deviation, but it should be adjusted within the tolerance.

Efter justering af vinkel indstilling, skal laserarmens friktion kontrolleres. Dette kan gøres med en trykfjedermåler, som holdes mod magneten på focus-enheden.

After adjusting the setting, the friction of the arm must be checked. This is done by means of a spring pressure gauge which is held against the magnet of the focusing unit.

Friktionen skal være under 25 mN gennem enhedens hele vandring.

The friction of the arm, measured over the entire meter reading, should not be greater than 25 mN.

Hvis friktionen er for høj skal RAFOC enheden udskiftes og vinkel indstillingen skal kontrolleres igen.

When the friction appears to be too high, the RAFOC unit must be replaced and the angle setting shall be checked once more.

Justering af vinkel indstilling gøres som beskrevet i det efterfølgende:

Adjustment of the angle setting is performed as follows:

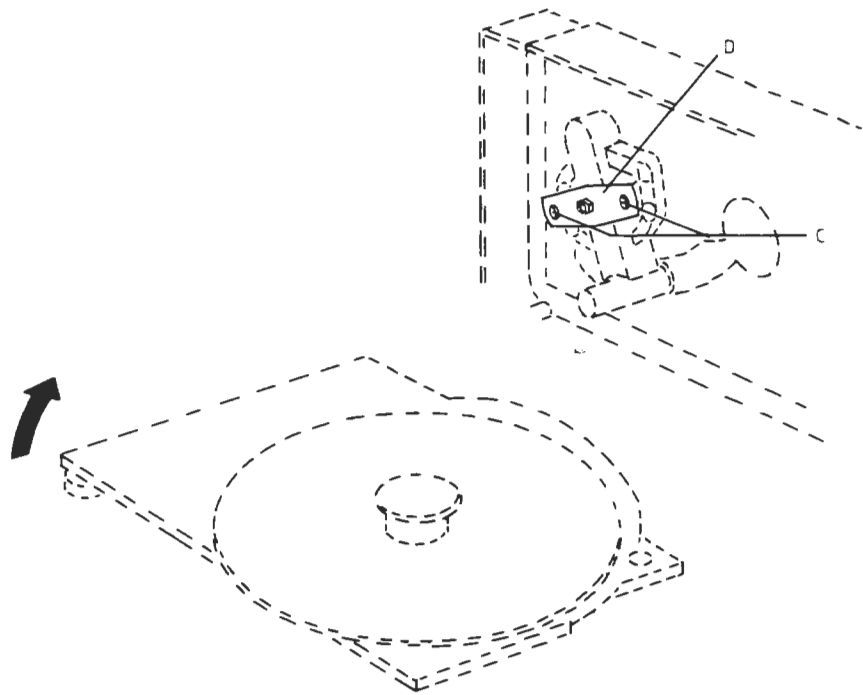

Skruerne C løsnes indtil armlejet D kan forskubbes. Vinkelindstillingen justeres ved at skubbe armlejet D som vist på nedenstående tegning.

Loosen screws C (see figure above) until bearing plate D can be displaced. Correct the angle setting by moving the bearing plate into the direction shown in figure below.

Skruerne C spændes medens det sikres at indstillingen ikke flytter sig.

Tighten screws C, ensuring that the setting does not drift.

Foretag kontrol af vinkelindstilling.

Then double check the setting in two directions.

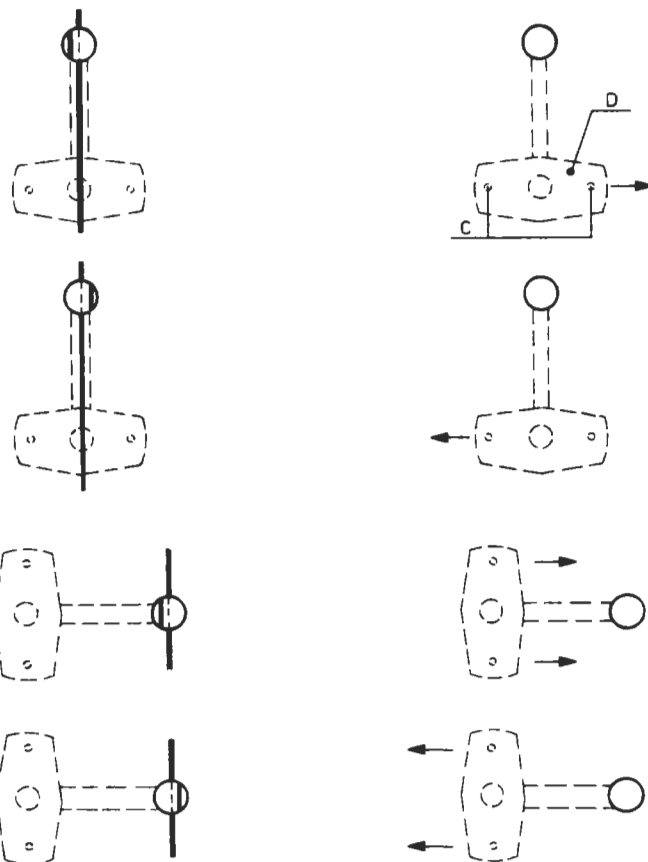

Udskiftning af fleks PCB pos. 9609

Afmonter RAFOC enheden.

Replacing the flexible PCB pos. 9609

Demount the RAFOC unit.

De 2 tilslutninger A kan nu loddes fra, og før tilslutningerne C loddes fra, skal placeringen af fleks-PCB'en markeres på fotodiode PCB'en.

Desolder the connections A of the flexible PCB.

Dette gøres ved hjælp af en blyant, så den nye fleks-PCB kan placeres i nøjagtig samme position.

Before desoldering the connections C of the photodiode PCB, the position of the connecting points of the photodiode PCB should be marked, so that afterwards the PCB can correctly be replaced.

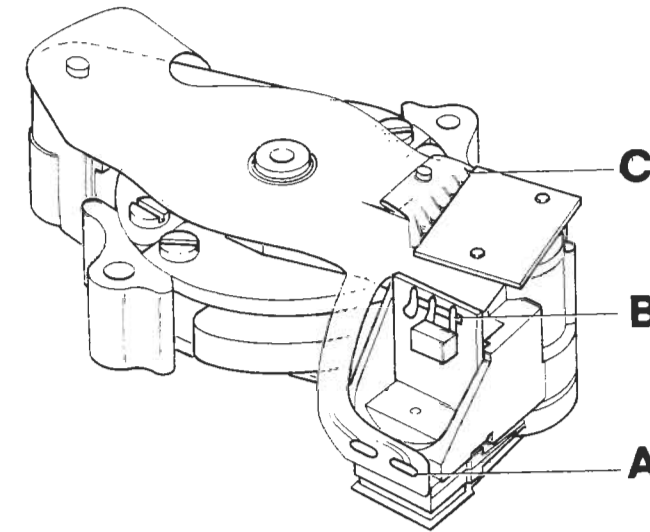

Fralodningen af de 6 tilslutninger C skal gøres ved at varme hver enkelt tilslutning op og løsne forbindelsen med f.eks. bagkanten af et skalpelblad. N.B. Dette skal gøres med stor forsigtighed. Herefter fraloddes de 4 tilslutninger til radiale spolerne inden de 3 tilslutninger (B) til laser PCB'en loddes fra.

Now the 6 connections C of the photodiode PCB can be desoldered by heating the pins C one by one until the flexible PCB comes loose. This should be done very carefully.

PCB'en kan nu løftes af, og inden den nye PCB monteres, loddes et lille lag loddetin på tilslutningerne C.

Desolder the 4 connections of the radial coils. Unsolder the 3 connections (B) of the laser PCB.

Den nye fleks-PCB placeres nu korrekt i.flg. blyantsmærkerne og tilslutningerne til de radiale spoler loddes nu fast inden tilslutningerne A og B.

The PCB can now be taken off, and before the new PCB is mounted, the connections C should be provided with a small coating of tin.

PCB'en placeres på plads under fotodioden PCB'en, og hver enkelt tilslutning varmes let op med en lodde-købe, til lodningerne løber sammen.

The new PCB is now placed according to the marks on the photodiode PCB, and the 4 connections of the radial coils are soldered before the connections A and B.

For montering af RAFOC enheden, se afsnittet om servicering af RAFOC enhed.

Now the PCB is placed correct below the photodiode PCB, and the 6 connections C can now be heated so that they become soldered to the photodiode PCB.

For mounting the RAFOC unit, see section concerning servicing the REFOC unit.

Udskiftning af focus enhed pos. 9604

De 2 tilslutninger fra fleks PCB'en til focus enheden loddes fra.

Replacing the focusing unit pos. 9604

Desolder the 2 connections of the flex PCB on the focusing unit.

Skruen der holder focus enheden skrues ud. Bemærk, gevindstykket (pos. 9606) vil gå løs.

Remove the screw fastening the focusing unit. As a result the fixing piece (pos. 9606) will come loose.

Focus enheden kan nu tages af.

The focusing unit can now be removed.

Ved montering af ny focus enhed er placeringen fikseret, og justering er ikke mulig.

When mounting the new focusing unit the position is fixed, adjustments are not possible.

SERVO PCB 30

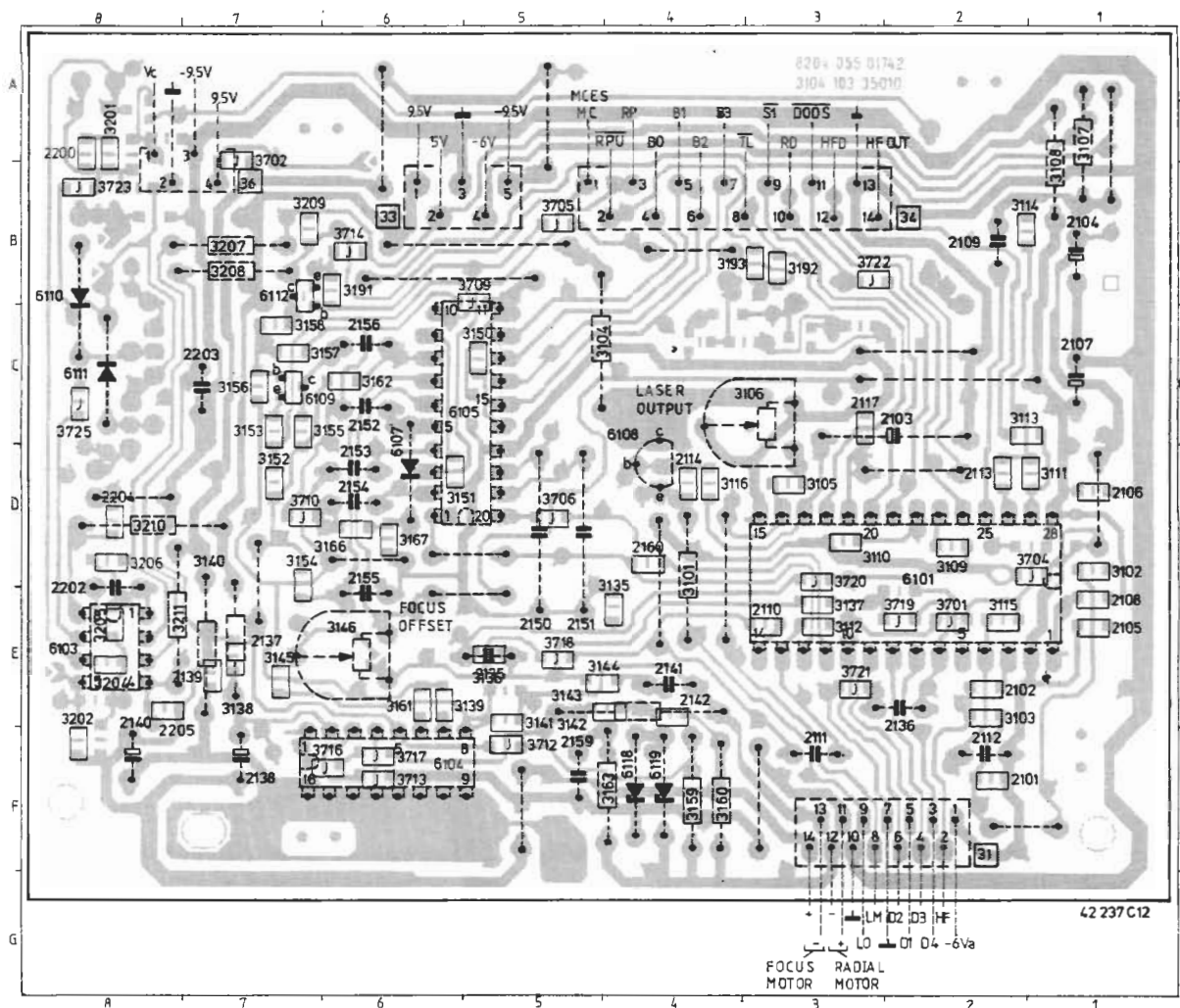

DISC MOTOR CONTROL

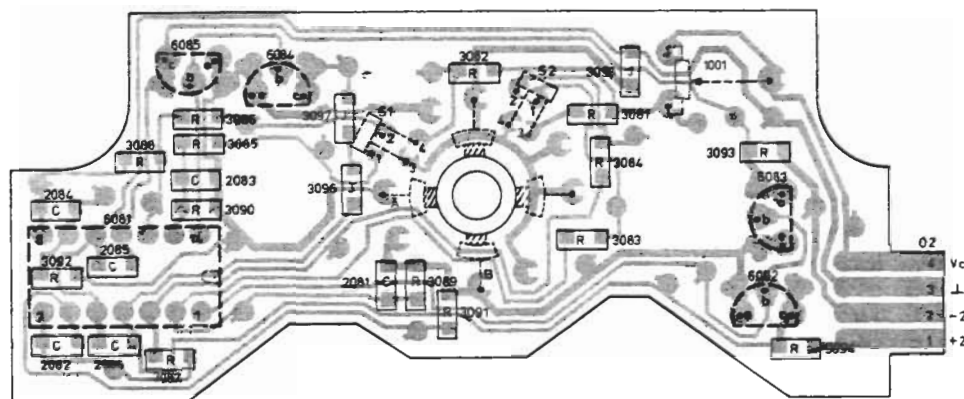

Kontrol af laserforsyning

Laseren, laserforsyningen i 30IC6101 og monitor dioden danner et tilbagekoblings system. En fejl i laserforsyningen kan medføre at laseren ødelægges. Hvis dette er tilfældet, og laseren (= komplet RAFOC enhed) udskiftes, vil den nye laser også ødelægges.

Da det er umuligt at kontrollere og reparere et tilbagekoblingssystem hvor en af komponenterne mangler, kan nedenstående kredsløb bruges til at kontrollere laserforsyningen.

Den grønne LED udgør laseren. Spændingen over 18 ohms modstanden udgør monitor tilbagekoblings spændingen. 33 ohms modstanden og omskifteren gør det muligt at ændre strømforbruget fra laserforsyningen.

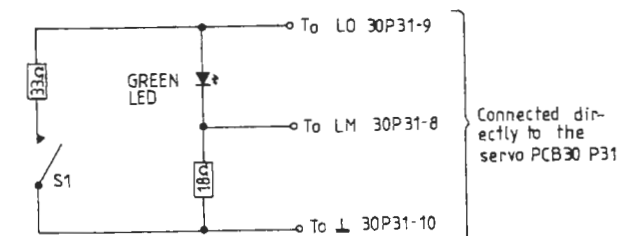

Grøn LED f.eks. CQY94 bestillings. nr. 8330054.

Fleks printet tages ud af P31 på servo PCB'en.

Ovenstående kredsløb loddes på P31 på servo PCB'en.

SI (ben 20 på 30IC6101) kortsluttes til stel.

Når SI (Start initialization) er low, kan laserforsyningen tændes i service position 1. Sæt apparatet i service position 1. (Kortslut service stikket på PCB5 samtidig med at netstikket sættes i). Tryk derefter OPEN og PLAY samtidigt.

LO spændingen på 30P31 ben 9 måles.

S1 afbrudt: LO fra 1,8 V til 2,3 V
LM fra 170 mV til 220 mV
Den grønne lysdiode lyser svagt.

S1 kortsluttet: LO fra 1,8 V til 2,3 V
LM fra 170 mV til 220 mV
Den grønne lysdiode lyser svagt.

Når S1 skiftes fra kortsluttet til afbrudt vil LED'en lyse kraftigere i et kort øjeblik. Tilbagekoblings-systemet bevirker at der går samme strøm i LED hvad enten S1 er kortsluttet eller afbrudt.

Check of laser supply

The laser and the laser supply in 30IC6101 plus the monitor diode form a feedback system. A defect in the laser supply may result in the destruction of the laser.

If, in that case, the laser (= complete RAFOC unit pos. no. 9607) is replaced, the new laser will also become defective.

However, it is impossible to check and repair a feedback system if a link is missing. For this reason the laser supply can be checked with the circuit below.

The green LED replaces the laser, the voltage across the 18-Ohm resistor is fed back as monitor voltage, the 33-Ohm resistor and the switch serve to draw more current from the laser supply.

LED green e.g. CQY94 part no. 8330054.

Take the flex PCB out of P31 on the servo PCB.

Connect above mentioned circuit to P31 on the servo PCB.

Connect SI (pin 20 of 30IC6101) to ground.

With SI (start initialization) low, the laser supply can be switched on. Put the player in service position 1. (Short circuit the service plug on PCB5 and plug into mains supply at the same time). Then press OPEN and PLAY simultaneously.

Measure the voltage LO at 30P31 pin 9.

S1 open: LO from 1.8 V til 2.3 V
LM from 170 mV to 220 mV
The green LED emits little light.

S1 closed: LO from 1.8 V to 2.3 V
LM from 170 mV to 220 V
The green LED emits little light.

During the change over from S1 closed to S1 open, the LED will emit more light for a short moment. The control sees to it that the same amount of current flows through the LED when S1 is open and when S1 is closed.

Justering af laserstrøm

Bemærk! Ved udskiftning af RAFOC enheden (pos. nr. 9607) skal laser current potentiometeret (pos. nr. 30R3106) stilles i mekanisk midt position for at undgå beskadigelse af laseren.

Tilslut DC voltmeter over 30R3102.

Ilæg testplade nr. 5 (plade uden fejl, bestillingsnr. 3634031).

Sæt apparatet i serviceposition 2. (Kortslut servicetikket på PCB5 samtidig med at netstikket sættes i). Tryk derefter OPEN og PLAY samtidigt 2 gange.

Juster 30R3106 indtil spændingen over 30R3102 er ca. 40 mV. (Spændingen varierer hvis pladen roteres).

Gå ud af serviceposition 2 ved at afbryde netspændingen kortvarigt.

Afspil spor 1 på testplade 5.

30R3106 justeres indtil spændingen over 30R3102 er 50 mV \pm 5 mV.

Kontrol af disc motor systemet

1. Afbryd Vc forbindelsen ved at lodde 30D6110 og 30D6111 fra.

2. Tilslut den ene kanal på et dobbelt strålet oscilloskop til emitteren på 96TR6082, og den anden kanal til emitteren på 96TR6084. Indstil oscilloskopet til 2V - 10 mS.

3. Sæt apparatet i serviceposition 1. (Kortslut service stikket på PCB5 samtidig med at netstikket sættes i). Tryk derefter OPEN og PLAY samtidigt.

4. Tilslut en negativ DC spændingsforsyning (V-in) til 30P36-1. NB! Apparatet skal stå i service position 1 (strømforsyningen i apparatet skal være tændt) når dette gøres.

Start fra 0 V og reguler DC forsyningen mod - indtil motoren kører (max. -5 V).

Når motoren kører, ændres spændingen til -1,5 V.

Motoren skal stadig køre.

Adjusting the laser current

Attention: When exchanging the RAFOC unit (pos. nr. 9607), the laser output potentiometer (pos. nr. 30R3106) should be placed in mechanical mid-position to avoid damage to the laser.

Connect CD voltmeter across 30R3102.

Put test disc no. 5 (disc without defects part no. 3634031) on the turntable.

Put the player in service position. (Short circuit the service plug on PCB5 and plug into mains supply at the same time).

Then press OPEN and PLAY simultaneously and twice.

Adjust 30R3106 until the voltage across 30R3102 is about 40 mV. (This voltage varies when the disc is rotated).

Leave service position 2 by switching of the mains briefly.

Play track 1 of test disc 5.

Adjust 30R3106 until the voltage across 30R3102 is 50 mV \pm 5 mV.

Check of disc motor system

1. Interrupt the Vc connection by desoldering 30D6110 and 30D6111.

2. Connect channel A of a dual-beam oscilloscope to the emitter of transistor 96TR6082 on the motor PCB and channel B to the emitter of transistor 96TR6084. Position of the oscilloscope: 2 V/div - 10 ms/div.

3. Put the player in service position 1. (Short circuit the service plug on PCB5 and plug into mains supply at the same time). Then press OPEN and PLAY simultaneously.

4. Inject a *negative* voltage (V-in) to pin 1 of 30P36. This voltage *may only* be injected *after* the player is put in service position 1. (The power supply in the player must be ON).

Start from 0 V and lower this voltage fast until the motor is running (max. -5 V).

When the motor is running, the voltage can be reduced to -1.5 V.

The motor should keep on running.

5. Sinus signaler (V-out) skal nu være synlige på oscilloskopet. Efter ca. 2 sek. skal signalerne ligge symmetrisk omkring 0 V, og være 90° faseforskudt (se tegning). Størrelsesforholdet mellem de 2 signaler må højst være 1:2.

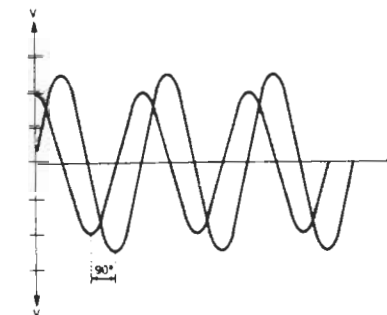

6. Amplituden er afhængig af størrelsen af den tilførte DC spænding.

Forholdet V-in/V-outpp skal ligge mellem 1:2 og 1:3.

DC spændingsforsyningen (V-in) ændres indtil motoren kører 600 omdr. min. (V-out frekvens = 30 Hz).

V-in skal ligge mellem -1,5 V og -3,7 V med 600 omdr. min.

8. Mål med oscilloskop, først over 96R3094, og derefter over 96R3093 på disc motor control PCB'en. De 2 stråler på et dobbelt strålet oscilloskop må ikke tilsluttes over de 2 modstande samtidig, da forsyningsspændingerne ellers kortsluttes. Spændingsforsyningen reguleres, indtil der ses 3 pulser med oscilloskopet på 100 mS. (se tegning).

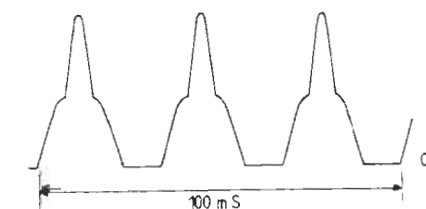

Oscilloskopet polariseres sådan, at pulserne vender som vist.

5. Now sinusoidal signals (v-out) should be present on the oscilloscope (see figure) which, after about 2 seconds, lie symmetrically round the 0-axis and have shifted 90° in phase relative to one another. The amplitudes of these 2 signals have a maximum permissible ratio of 1:2.

6. The amplitude is dependent on the injected voltage. The ratio V-in/V-outpp should lie between 1:2 and 1:3.

7. Now adjust V-in until the motor rotates 600 r.p.m. At 600 r.p.m. the frequency of V-out is 30 Hz. V-in should lie between -1.5 V and -3.7 V at this speed.

8. Measure with an oscilloscope first across 96R3094 and hereafter across 96R3093 on the disc motor PCB. DO not measure across both resistors at the same time, as this will cause short circuit of the power supplies. Now adjust the injected voltage in such a way that 3 complete pulses are visible during 100 mS. (See figure).

The polarity of the oscilloscope must be chosen so that the tops of the pulses are in upward position.

9. DC spændingsforsyningen reguleres til $-1.7 \text{ V} \pm 0.5 \text{ V}$ på P36-1 på servo PCB'en.

Reference spænding over 96R3094 = 56,4 mVpp.
Reference spænding over 96R3093 = 58,8 mVpp.
Hvis forskellen på de 2 spændinger er større end 6 mV, når spændingerne er lavere end reference værdierne, er motoren defekt.

9. Adjust the injected voltage until $-1.7 \pm 0.5 \text{ V}$ are present on pin 1 of P36 on the servo PCB.

Reference voltage across 96R3094 = 56.4 mVpp.
Reference voltage across 96R3093 = 58.8 mVpp.
If the difference of the 2 voltages exceeds 6 mV, while the voltages are below the reference values, the motor is defect.

10

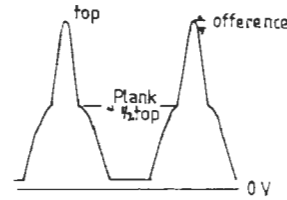

Toppen må højest variere 24 mV i amplitude.
Flanken må højest variere 36 mV i amplituden.

10

Top difference must not exceed 24 mVpp amplitude.
Flank difference must not exceed 36 mVpp amplitude.

11. Eksempler på pulsformer som er udtryk for fejl i disc motor systemet.

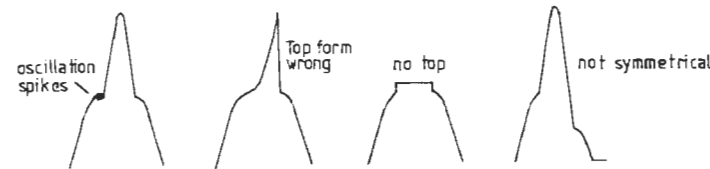

11. Examples of wave forms when the disc motor system is faulty.

12. DC spændingsforsyningen reguleres til -1.5 V på P36-1 på servo PCB'en.
Motoren skal stadig køre.
Pulsens amplitude falder, men pulsformen skal stadig være symmetrisk og afrundet.

12. Adjust the injected voltage until -1.5 V are present on pin 1 of P36 on the servo PCB.
The motor should keep on running
The amplitude of the pulse will be lower, but the wave form has to be symmetrical and rounded.

Konklusion:

Hvis ovennævnte punkter kan opfyldes, er disc motor systemet i orden.

Conclusion:

When all above mentioned conditions are fulfilled it may be assumed that the disc motor system is all right.

ADSKILLELSE

Transportsikring

Før brug fjernes de to transportskruer i bunden, og placeres som beskrevet på bunden.

Kabinet

DISASSEMBLY

Transport protection

Before use remove the two transport screws on the base and insert them as described on the base.

Cabinet

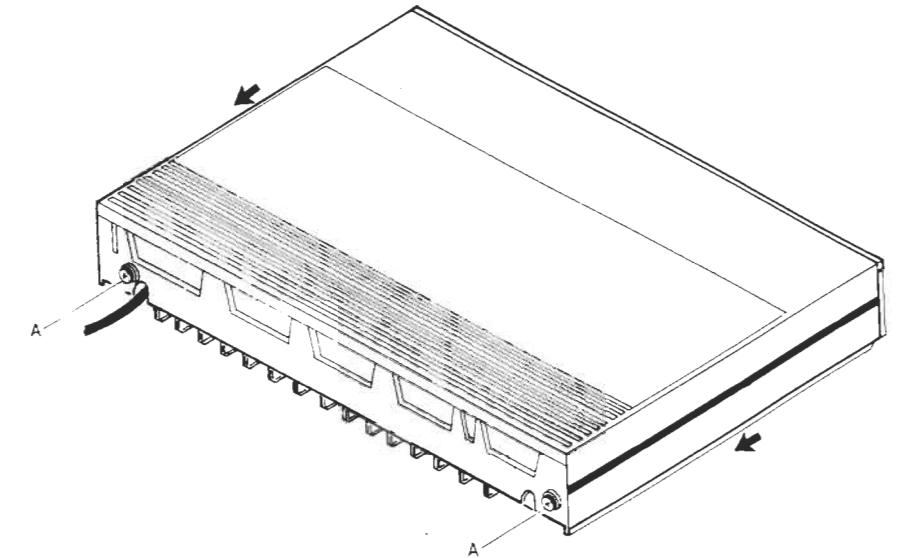
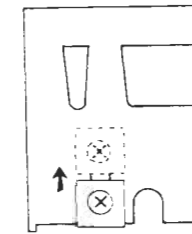

Skruerne (A) løsnes, skubbes op og spændes.

Kabinettet presses ca. 1 cm. bagud, og løftes af.

Loosen, push up and tighten screws (A).

Press the cabinet approx. 1 cm to the rear and lift off.

PCB

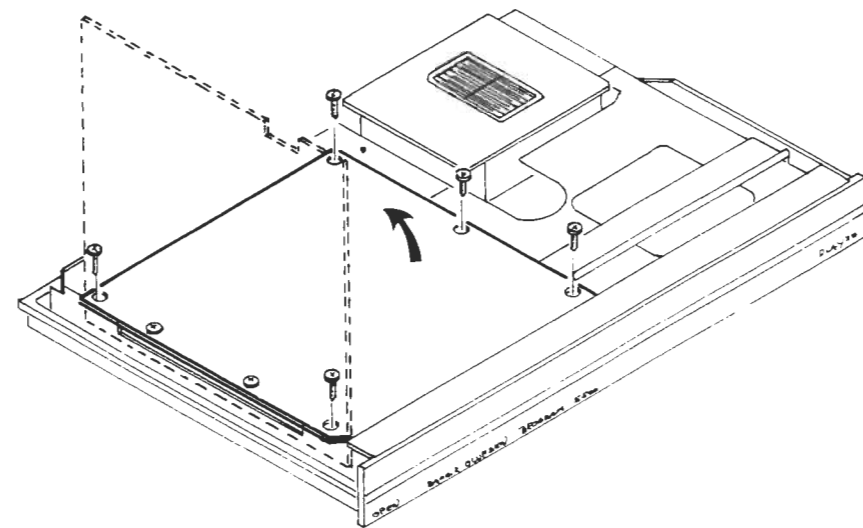

De 5 skruer fjernes.

PCB stilles i service position som vist.

PCB

Remove the five screws.

Place the PCB in service position as shown.

Frontpanel

Front panel

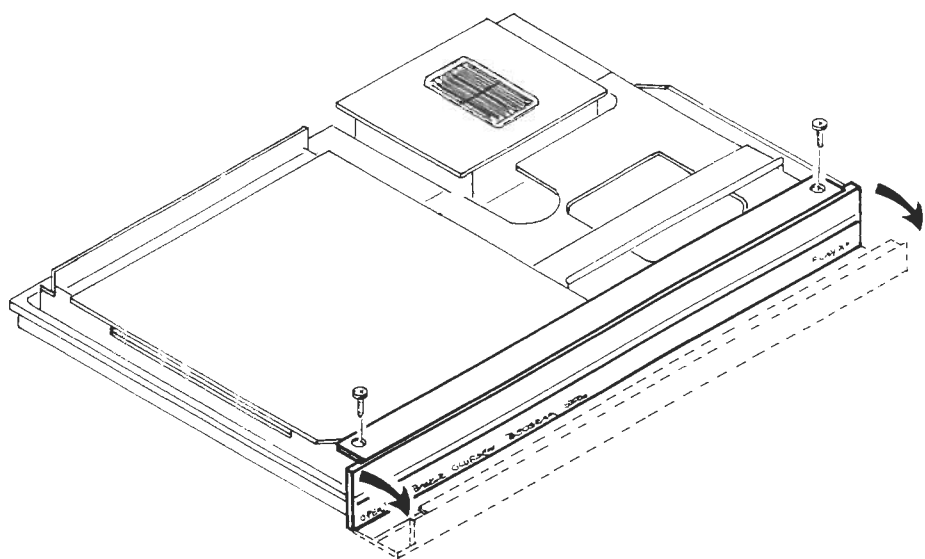

Afmonter de to viste skruer

Vip frontpanelet frem.

Remove the two screws as shown.

Tip the front panel forwards.

Disc skuffe

Disc tray

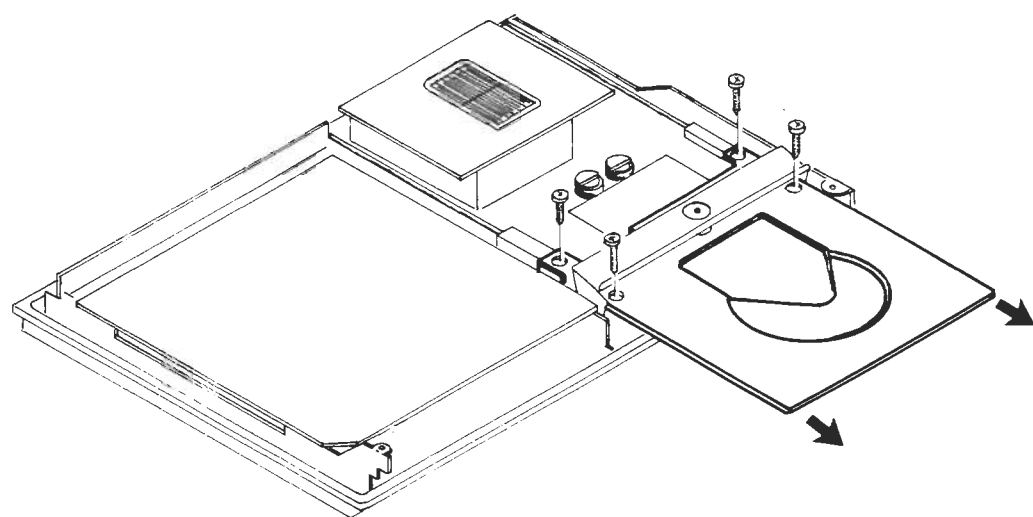

Afmonter de fire viste skruer.

Træk forsigtigt skuffen ud.

Remove the four screws shown.

Pull out the drawer carefully.

Disc holder

Disc holder

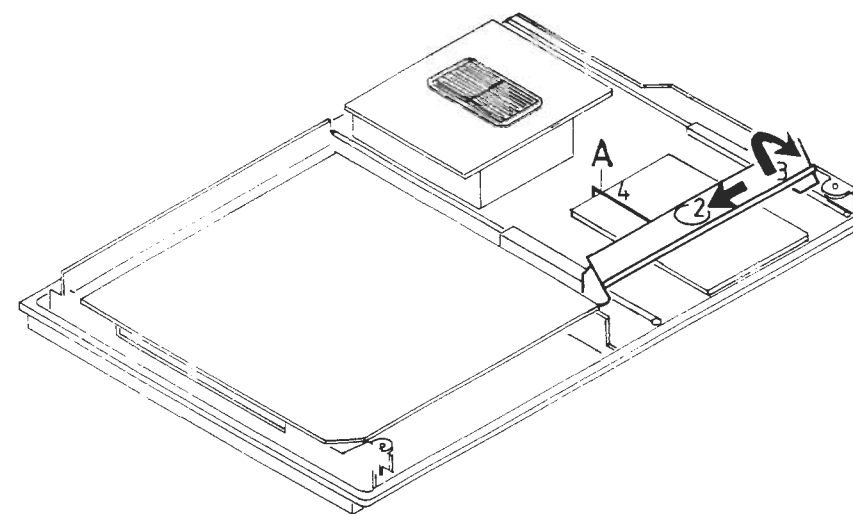
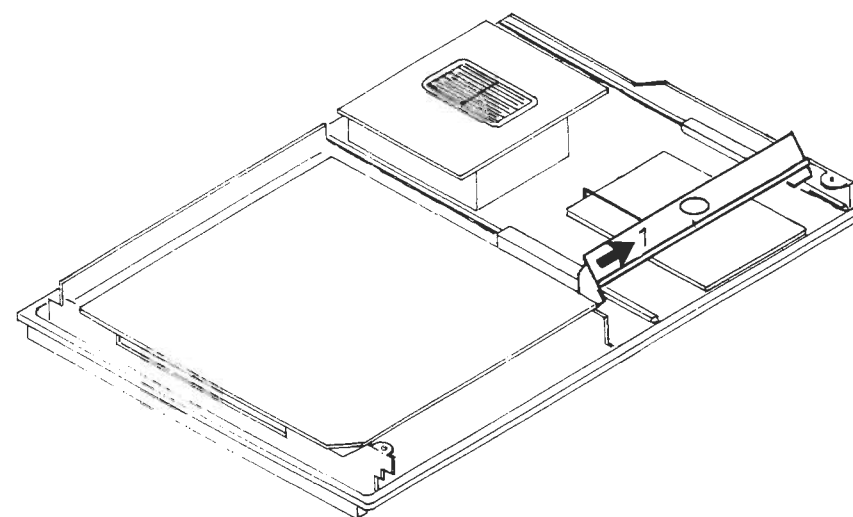

Skuffen skal stå i »OPEN« position.

1. Disc holderen vippes af plastakslen i venstre side.

2. Disc holderen vippes af plastakslen i højre side.

3. Disc holderen drejes i pilens retning.

4. Metalarmen (A) kan derefter trækkes af.

The disc tray must be placed in 'OPEN' position.

1. Tip the disc holder off the plastic shaft in the left side.

2. Tip the disc holder off the plastic shaft in the right side.

3. Carefully turn the disc holder in the direction of the arrow.

4. Carefully pull off the metalholder (A).

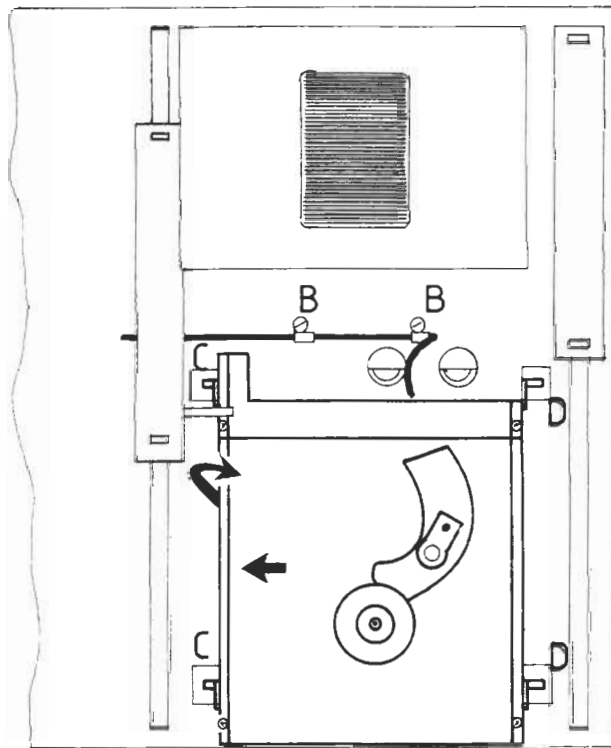

1. De to ledningsholdere (B) drejes med uret
2. De to plastflige (C) i bundpladen til venstre for løbeværket presses ned. Samtidig presses løbeværket mod venstre.
3. Løbeværket kan derefter forsigtigt løftes op i venstre side.
4. Til sidst trækkes løbeværket forsigtigt fri af de to holdere (D) i højre side.

NB! Undgå at trække i selve løbeværket, da det er fastgjort i gummistykker.

Vær også opmærksom på flexprintet mellem løbeværk og servo.
Undgå at udsætte dette flexprint for skarpe bøjninger.

1. Turn the two leadholders (B) clockwise.
2. Push the two plastic tags (C), which are placed in the bottom plate on the left of the CD mechanism, down. Simultaneously push the mechanism to the left.
3. Now carefully lift off the mechanism in the left side.
4. After that the mechanism can be pulled off the lead holders (D) in the right side.

NOTE! Avoid pulling the mechanism itself, as it is hanging in four rubber pieces.

Be aware of the flex PCB between the mechanism and the servo.
Avoid bending this PBC sharply.

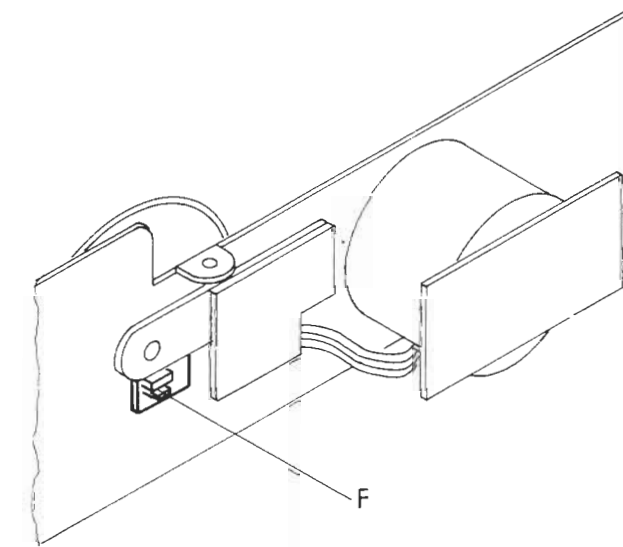

Plastfligen (F) presses op.
Træk snorhjulet af akslen.

Skuffemotor pos. nr. 06M1

Push the plastic tag (F) upwards.
The cord pulley can now be pushed off the shaft.

Tray motor Pos. no. 06M1

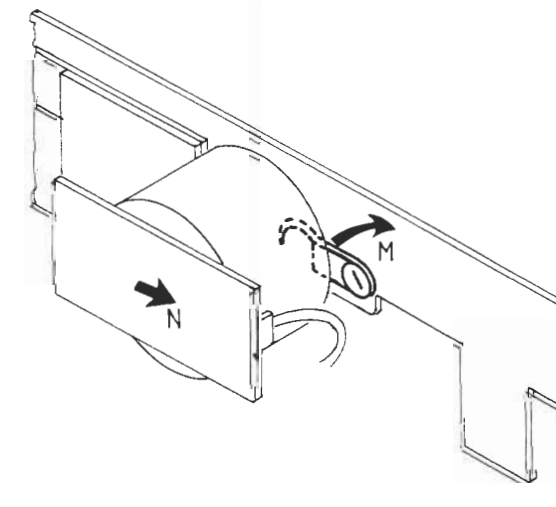

Plastkrogen (M) drejes op.

Skud skuffemotoren ud af holderen i pilens retning (N).

Turn the plastic hook upwards. (M)

The cord pulley can now be pushed out in the direction of the arrow (N)

REPARATIONSTIPS

Serviceprogram

Kortslut servicestikket på PCB5, samtidig med at netstikket sættes i.

REPAIR HINTS

Service program

Short-circuit the service plug on PCB5 and plug into mains supply at the same time.

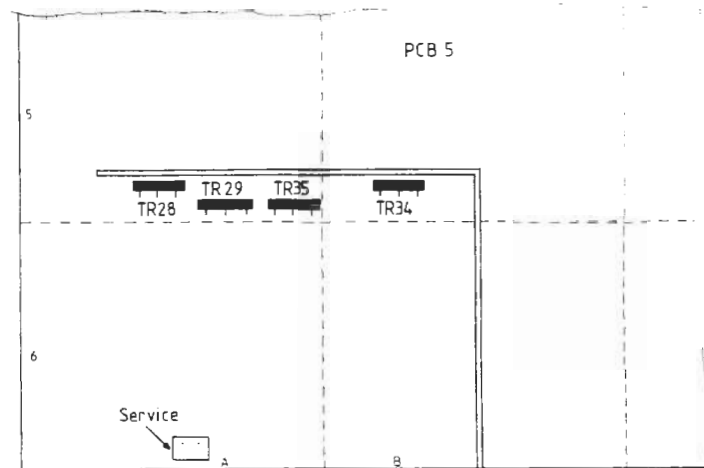

| | | |
|------------------------------------|---|---|
| Tast OPEN og PLAY samtidigt | Display indikerer serviceposition 1. | |
| Press OPEN and PLAY simultaneously | Display indicates service position 1. | |
| Tast PLAY | Laserarm svinger ud. | <i>Hvis arm bliver stående:</i> Er fleks-PCB rigtigt placeret? Går radialspole imod? Er trægheden i armlejet for stor? |
| Press PLAY | Laser arm swings out. | <i>If arm doesn't move:</i> Is flex-PCB placed correctly? Does radial coil touch? Is arm bearing inertia excessive? |
| Tast OPEN | Laserarm svinger ind. | <i>Hvis arm bliver stående:</i> Er fleks-PCB rigtig placeret? Går radialspole imod? Er trægheden i armlejet for stor? |
| Press OPEN | Laser arm swings in. | <i>If arm doesn't move:</i> Is flex-PCB placed correctly? Does radial coil touch? Is arm bearing inertia excessive? |
| Ilæg CD-plade | | |
| Load compact disc | | |
| Tast OPEN and PLAY samtidigt | Display indikerer 2. Laser tænder og søger focus. | <i>Hvis 2 i displayet blinker:</i> CD bliver ved med at søge i focus, indtil der tastes OPEN og PLAY samtidigt. Tændes laser? Regulerer FE-udgangen til focus motoramplifier? Regulerer focusmotor? |
| | Hvis display indikerer 2 konstant: Focussøgning i orden. | |

| | | |
|---|--|--|
| Press OPEN and PLAY simultaneously | Display indicates 2. Laser switches on and searches for focus. If display indicates constant 2: Focus search is OK. | <i>If 2 in the display flashes:</i> CD continues searching for focus until OPEN and PLAY are pressed simultaneously. Does laser switch on? Does FE output controlling focus motor amplifier regulate? Does focus motor regulate? |
| Tast OPEN og PLAY samtidigt | Display indikerer 3. CD-motor starter rotation og laser placeres mod centrum. | <i>Hvis CD-plade ikke roterer:</i> Starter RD-udgangen turntable motoramplifier? Er MCES-pulsen tilstede? |
| Press OPEN and PLAY simultaneously | Display indicates 3. CD motor starts rotation, and the laser is positioned towards the centre. | <i>If compact disc doesn't rotate:</i> Does RD output start the turntable motor amplifier? Is MCES pulse present? |
| Tast OPEN og PLAY samtidigt | Display indikerer 4. Radialsøgning startes. Hvis display indikerer 4 konstant. Radial søgning i orden. | <i>Hvis 4 i displayet blinker:</i> Regulerer RE-udgangen til radial motoramplifier? Subcode info er ignoreret. Musik kan høres, fordi MUSB er høj men er afhængig af lead-in sporets længde. Kan vare op til 1 min. |
| Press OPEN and PLAY simultaneously | Display indicates 4. Radial search is started. If display indicates constant 4. Radial search is OK. | <i>If 4 in the display flashes:</i> Does RE output controlling radial motor amplifier regulate? Subcode info has been ignored. Music is audible because MUSB is high but dependet on length of lead-in track. May last up to 1 minute. |
| Tast PLAY | Display forbliver i 4 konstant. Laserarm springer ud over spor. | <i>Hvis 4 i displayet blinker:</i> Kontroller radialservo. |
| Press PLAY | Display remains in 4 constantly. Laser arm jumps out across tracke. | <i>If 4 in the display flashes:</i> Check radial servo. |
| Tast OPEN | Display forbliver i 4 konstant. Laserarm springer ind over spor. | <i>Hvis 4 i displayet blinker:</i> Kontroller radialservo. |
| Press OPEN | Display remains 4 constantly. Laser arm jumps in across tracks. | <i>If 4 in the display flashes:</i> Check radial servo. |
| Serviceprogrammet kan gentages ved at taste OPEN og PLAY samtidigt. Displayet indikerer da kort efter serviceposition 1. Serviceprogrammet afsluttes ved kortvarigt at fjerne netstikket. | | The service program can be repeated by pressing OPEN and PLAY simultaneously. The display will shortly afterwards indicate service position 1. The service program is terminated by briefly disconnecting the mains supply. |

Oversigt over IC ben

Nedenstående skemaer er en kort beskrivelse af funktionen af de vigtigste ben på servo og decoder IC'erne.

De steder hvor 2 IC'er har direkte forbindelse med hinanden, er der kun nævnt benet på den ene IC.

IC pin survey

The following surveys shortly describes the function of the most important pins of the servo and decoder IC's.

Where 2 IC's are directly connected only one pin is mentioned

51C6 MAB 8441

| PIN | BEMÆRKNINGER/REMARKS | PLAY POSITION | SERVICE POSITION 1 | SERVICE POSITION 2 | SERVICE POSITION 3 | SERVICE POSITION 4 | SEARCH POSITION |
|-----|--|---------------|--------------------|--------------------|--------------------|--------------------|-------------------------------|
| 21 | SI (Start Initialization). Når SI er »low«, er laserforsyningen og focus styring tændt. When SI is 'low' the laser supply and the focus control are switched on. | »Low« | »High« | »Low« | »Low« | »Low« | »Low« |
| 7 | RD (Ready). Med plade på pladeholderen vil RD forblive »high« når focuspunktet er fundet. With a disc on the turntable, RD stays 'high', when the focal point has been found. | »High« | »Low« | »High« | »High« | »High« | »High« |
| 20 | SSM (Motor Start-Stop signal). Når RD er gået »high«, vil SSM være »high« i et kort øjeblik (<0,2 sek.), og discmotor forstærkeren tændes (styret af MCES signalet). When, after RD 'high', the SSM is high for a short moment (<0.2 sec.), the disc motor amplifier will be switched on (controlled by the MCES signal). | 136 µS | »Low« | »Low« | 136 µS | 136 µS | 136 µS |
| 8 | B0 } Tænder radial kontrol. Styrer niveauet på radial servo DAC udgang. I søge position vil der være aktivitet på alle 4 udgange. B1 } B2 } Switches the radial control on. Controls the level on the radial servo DAC output. B3 } In search mode, there should be activity on all 4 pins. | »High« | »Low« | »Low« | »Low« | »High« | »Activity« |
| 9 | | »High« | »High« | »High« | »High« | »High« | »Activity« |
| 10 | | »High« | »High« | »High« | »High« | »High« | »Activity« |
| 11 | | »Low« | »Low« | »Low« | »Low« | »Low« | »Activity« |
| 12 | TL (Track Loss). TL giver information til 51C6 om at tab af spor kan være forestående. 51C6 kan så give korrektionssignaler med B0-B3. TL tells 51C6 that track loss treatmentens. 51C6 can give correction signals with B0-B3 | »High« | »High« | »Low« | »Activity« | »High« | »Activity« |
| 13 | RP (Radial Position). RP bestemmer laserarmens position i forhold til sporet, og korrigerer ved spring over spor og ved mekaniske stød mod apparatet. RP determines the position of the arm relative to the track and to check/correct in case of track jumping or bumping against the player | | | | »Activity« | | »Activity« |
| 22 | DODS (Drop Out Detector Suppression). Når DODS er »low«, har drop out signaler ingen indflydelse på styringen af laserarmen under søg. When DODS is 'low' drop out signals do not influence on the arm control during track jumping. | »High« | »Low« | »Low« | »Low« | »High« | »Activity« |
| 6 | RPU (Radial Pulse). RPU aflader 30C2156 under søg. 30C2156 virker som hukommelse for stigningsgraden på pladen. During search, RPU clears 30C2156. 30C2156 memorizes the degree of inclination of the disc. | »High« | | | | »High« | »Activity« 0.1 mS/ Div. |

| PIN | E |
|-----|--------|
| 17 | M |
| 25 | F * |
| 26 | F * |
| 27 | C * |
| 39 | V |
| 38 | C |
| 37 | I |
| 36 | I |
| 30 | C |
| 31 | C |
| 29 | C |
| 33 | |
| 35 | |
| 34 | |

5IC7 SAA7210

| PIN | BEMÆRKNINGER/REMARKS | PLAY POSITION | SERVICE POSITION 1 | SERVICE POSITION 2 | SERVICE POSITION 3 | SERVICE POSITION 4 | SEARCH POSITION |
|-----|---|---------------|--------------------|--------------------|--------------------|--------------------|-----------------|
| 17 | MCES (Motor Control). MCES styrer discmotorens hastighed. MCES controls the turntable motor speed. | A1/A2 | A2 | A2 | A1/A2 | A1/A2 | A1/A2 |
| 25 | HF (High Frequency). Indgang for HF øje mønster. *Efter lead-in er læst HF eye pattern input. *After lead-in has been read. | B (Stable) | | | B (Unstable) | B* (Stable) | >Activity< |
| 26 | HFD (High Frequency Detector). HFD vil gå »low« når HF signalet er for svagt. *Ved afspilning af testplade 5A, vil HFD give »low« pulser på spor med afbrydelser og sorte pletter. HFD will go 'low' when the HF signal is too low. *When playing test disc 5A, track numbers with interruption or black dot, HFD will make low pulses. | >High<* | | | | >High< | >Activity< |
| 27 | CEFM. Spændings kontrolleret oscillator udgang. *Hvis pladen bremses forsigtigt med hånden, vil oscillator frekvensen falde. CEFM. Voltage controlled oscillator output. *When the disc is slowly braked by hand, the oscillator will lower its frequency. | 4.32 MHz* | 2.82 MHz | 2.82 MHz | 4.32 MHz* | 4.32 MHz* | 4.32 MHz |
| 39 | WS (Word Select) | D | | | D | D | D |
| 38 | Clock | D | | | D | D | D |
| 37 | Data | >Activity< | | | | >Activity< | >Activity< |
| 36 | E Flag (Error Flag). Indikerer utroværdige samples for 8 sample interpolator. Indicates untrustworthy samples for 8 sample interpolator. | | | | | | >Activity< |
| 30 | QRA (Q-channel Request Acknowledge). | F | | | | F | |
| 31 | QCL (Q Clock). | F | | | | F | |
| 29 | QData QRA initieres af 5IC6 med »high«, 5IC7 svarer med »low«. Ved forkanten på næste clock puls sættes QRA »high« igen af 5IC6. Når 5IC6 har modtaget nok information (via Q Data), går QRA »low«. Dette gør at QRA tiden varierer. QRA is initiated by 5IC6 with 'high', 5IC7 answers with 'low'. With the next leading clock (Q CL) the QRA is set 'high' again by 5IC6. When 5IC6 has taken enough information (via Q Data), QRA will go 'low'. This makes the QRA times vary each time. | F | | | | F | |
| 33 | SW (Subcode Word clock). | G | | | G | G | |
| 35 | SC (Subcode Clock). | | | | | | |
| 34 | SD (Subcode DATA) Efter Motor Start Pulse vil Subcode Word Clock være synlig. Medens en burst på 10 clock pulser er synlig på SC, overføres Q-channel information på SD. Herefter følger P-bit indikation. P-bit indikationen kommer mellem 2 bursts på 10 clock pulser. Ved pause er P-bit indikationen »high« og ved musik er den »low«. After Motor Start Pulse, Subcode Word Clock is visible. While the burst of 10 clock pulses appear on SC, the Q-channel information is transferred on SD. Hereafter the P-bit indication follows. The P-bit is 'high' between two bursts of 10 clock pulses in case of pause indication, and 'low' in case of music indication. | | | | | | |

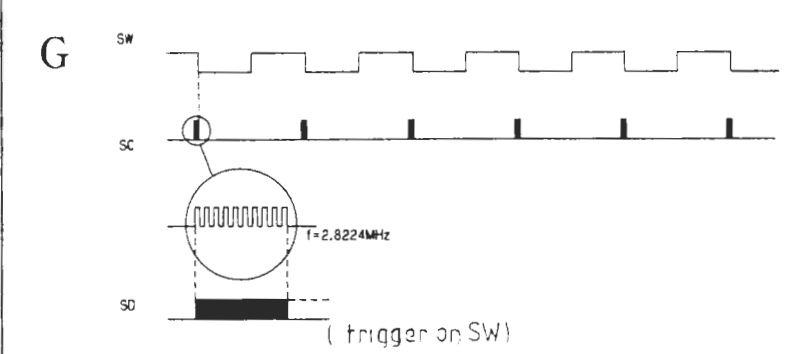
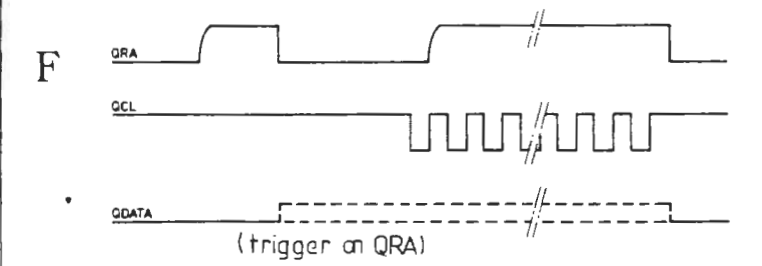
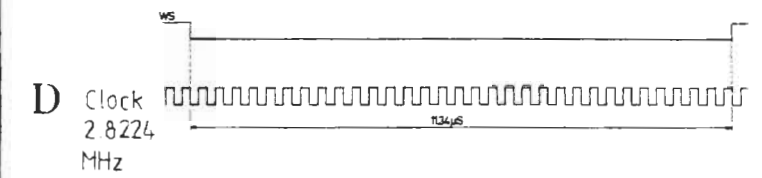
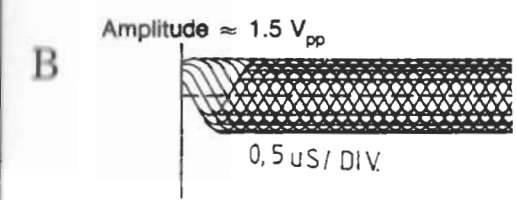
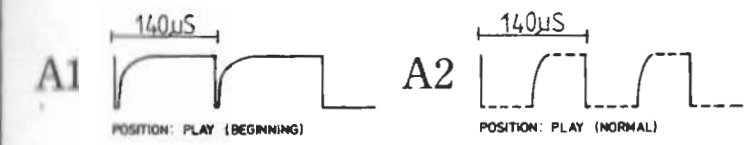

| PIN | BEMÆRKNINGER/REMARKS | PLAY POSITION | SERVICE POSITION 1 | SERVICE POSITION 2 | SERVICE POSITION 3 | SERVICE POSITION 4 | SEARCH POSITION |
|-----|---|---------------|--------------------|--------------------|--------------------|--------------------|-----------------|
| 28 | CRI (Counter Reset Inhibit). CRI er »low« ved spring over spor. CRI is 'low' in case of track jumping. | »High« | | | | »High« | »Activity« |
| 32 | DEEM (Deemphassis). »Low« ved afspilning af testplade 5A spor 14. »High« ved afspilning af testplade 5A spor 15. 'Low' when playing test disc 5 track no. 14 'High' when playing test disc 5 track no. 15 | | | | | | |
| 19 | OSC. Indgang fra krystal oscillator. Input from crystal oscillator | 11.28 MHz | 11.28 MHz | | | 11.28 MHz | |
| 11 | MUTE. Muter audio signalet Mutes the audio signal | »High« | | | | »High« | »High« |
| 22 | PD/OC (Phase Detector/Oscillator Control). Pulser fra fasedetektorens udgang integreres og regulerer oscillatorfrekvensen. Pulses from the output of the phasedetector are integrated and controls the oscillatorfrequency. | | | | | | |
| 23 | IREF. Strøm reference til fasedetektoren. Current reference for the phasedetector. | | | | | | |
| 24 | FB (Feed Back). Fastholder data slicerens arbejds punkt. Keeps the operating point for the data slicer. | | | | | | |

5IC9 SAA 7220

| PIN | BEMÆRKNINGER/REMARKS | PLAY POSITION | SERVICE POSITION 1 | SERVICE POSITION 2 | SERVICE POSITION 3 | SERVICE POSITION 4 | SEARCH POSITION |
|-----|--|---------------|--------------------|--------------------|--------------------|--------------------|-----------------|
| 18 | WS (Word Select) | I | I | I | I | I | I |
| 16 | Clock | | | | | | |
| 15 | Data | »Activity« | »Stable« | »Stable« | »Stable« | »Activity« | »Activity« |
| 22 | ATSB (Attenuation Audio Signal). Ved »low« dæmpes signalet 12 dB. When 'low', the signal is lowered with 12 dB | | | | | | |
| 23 | MUSB (Soft Mute). MUSB er »low« ved spring fra et spor til et andet. *Vil være »high« ved søgning i serviceposition 4. MUSB is 'low' when jumping from one track to another. *Will be 'high' when using search in service position 4. | »High« | | | | »High« | *»Low« |
| 14 | DOBM (Digital Output). Fejlkorrigeret audio og subcode data. Error corrected audio and subcode data. | | | | | | |

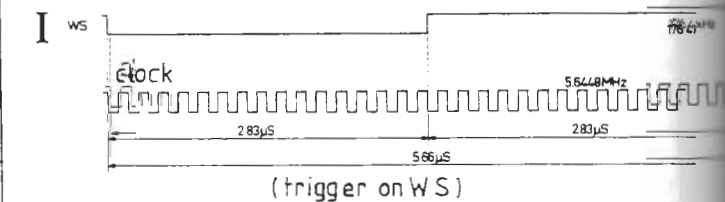

30IC6101 TDA 5708

| PIN | BEMÆRKNINGER/REMARKS | PLAY POSITION | SERVICE POSITION 1 | SERVICE POSITION 2 | SERVICE POSITION 3 | SERVICE POSITION 4 | SEARCH POSITION |
|-----|---|------------------|--------------------|--------------------|---------------------|--------------------|-----------------|
| 17 | LO (Laser Out). | »High« | »Low« | »High« | »High« | »High« | »High« |
| 16 | LM (Laser Monitor) Via LM styres strømforsyningen til laser dioden. Via the LM the power supply for the laser diode is controlled. | 200 mV ±50 mV | | 200 mV ±50 mV | | | |
| 5 | FE (Focus Error). FE styrer focus enheden. Når SI går »high« søges der efter focus punktet. Når apparatet sættes i serviceposition 2 uden plade, vil optikket søge efter focus punktet. På ben 5 vil FE signalet variere mellem 0 V og +4 V. FE drives the focusing unit. When the SI goes 'high', the focal point will be searched for. When the player is brought into servicing position 2 without disc, the objective will search for the focal point. At pin 5 the FE signal varies between 0 V and +4 V. | | | | | | |
| 9 | D1 D1→D4 er korrektionssignaler for fotodiode kredsløbet. Hvis pladen bevæges når apparatet er i serviceposition 2, skal focusenheden holde focus. | | | | | | |
| 10 | D2 Når pladen bevæges, skal der være varierende signaler på ben 7, 8, 9 og 10. | | | | | | |
| 8 | D3 D1→D4 are the error signals from the photodetector circuits. When in servicing position 2 the disc is moved, the focusing unit should keep the laser beam in focus. | | | | | | |
| 7 | D4 When the disc is moving, there should be a changing signal on pin 7, 8, 9, 10. | | | | | | |
| 3 | HF (High Frequency). HF information fra de 4 fotodioder. HF information from the 4 photodiodes. | | | | | | |
| 27 | HF out (High Frequency out). HF out er et forstærket informationssignal til decoderen. *Efter lead-in er læst. HF out is the amplified information signal for the decoder. *After lead-in has been read. | B (Stable) | | | B (Unstable) | B* (Stable) | |
| 26 | DET (Detector). | | | | | | |
| 19 | HFD (High Frequency DETECTOR). | | | | | | |
| 18 | TL (Track Loss). DET giver information om HF signalets niveau til niveau/drop-out detektoren i 30IC6101. Når HF signalets niveau er for lavt, vil HFD gå »low«. TL vil så gå »low« som information til 5IC6 om at sporings signalerne er upålidelige. DET gives information on the level of the HF signal to the level/drop-out detector in 30IC6101. When the level of the HF signal is too low, HFD will go 'low'. TL will then go 'low' in order to tell 5IC6 that the tracking signals are unreliable. | | | | | | |
| 11 | RE1 (Radial Error). RE1-2 er styresignaler til sporing af laseren. | | | | | J | |
| 12 | RE2 RE1-2 are the control signals for the arm during tracking. | | | | | | |
| 25 | SC (Start Capacitor). *Stiger til +5 V hvis focus punktet er fundet. *Rises to +5 V if focus point is found. | | -5 V | * | +5 V | +5 V | |
| 6 | FE lag (Focus Error). *Når pladen bevæges, vil signalet variere. *When the disc is moved by hand, the signal will vary. | | | * | Approx. 100 mVpp | | |
| 13 | AGC. *Ved maksimum HF signal ≤-400 mV. Ved ingen HF signal +5 V. *At maximum HF signal ≤-400 mV. At no HF signal +5 V. | * | »High« | »High« | * | * | |

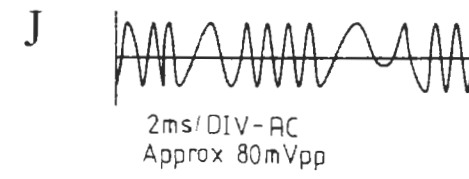
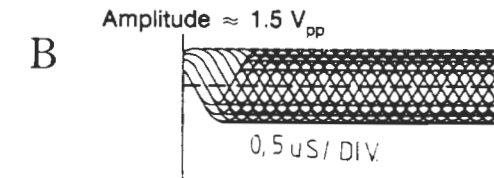

30IC6102 TDA 5709

| PIN | BEMÆRKNINGER/REMARKS | PLAY POSITION | SERVICE POSITION 1 | SERVICE POSITION 2 | SERVICE POSITION 3 | SERVICE POSITION 4 | SEARCH POSITION |
|-----|---|-------------------|--------------------|--------------------|--------------------|--------------------|-----------------|
| 10 | <p>DAC (Digital to Analogue Converter). DAC styrer hastigheden på spring over spor. Signalet er genereret af B0-B3. *Når man banker forsigtigt på apparatet vil der være aktivitet.</p> <p>DAC controls the track jumping speed. The signal is derived from the signals B0-B3. *Knock carefully on the set, and there should be activity.</p> | * | | | »Low« | * | »Activity« |
| 7 | <p>RE (Radial Error). RE holder lyspletten på sporet. *En 650 Hz sinus vil være synlig i RE signalet.</p> <p>RE keeps the light spot on track. *A 650 Hz sine wave should be visible in the RE signal.</p> | * | | | | * | |
| 8 | <p>RE lag (Radial error for lag network). 30C2156 i RE lag kredsløbet har en hukommelsesfunktion. Den husker stigningsgraden på pladen. Når der springes til et givet spor på pladen, skal denne hukommelse tømmes. Det gøres med 5IC6 via 30TR6109. *En 650 Hz sinus vil være synlig i RE lag signalet.</p> <p>30C2156 in the RE lag circuit has a memory function. It memorizes the degree of inclination on the disc. When a jump is made to a certain track on the disc, the memory should be cleared. This is done by 5IC6 via 30TR6109. *A 650 Hz sine wave should be visible in the RE lag signal.</p> | * | | | | * | |
| 4 | D factor. (Offset control). Typical 0V | Min.Gain -2.5V | +4 | | -0.5V | -1V/-1.5V | |
| 5 | K factor. (Gain control). Typical -1V/-1.5V | Max.Gain -0.5V | | | | | |

5IC4 MAB 8461

| PIN | BEMÆRKNINGER/REMARKS | PLAY POSITION | SERVICE POSITION 1 | SERVICE POSITION 2 | SERVICE POSITION 3 | SERVICE POSITION 4 | SEARCH POSITION |
|--------|--|---------------|--------------------|--------------------|--------------------|--------------------|-----------------|
| 1 | DATA LINK Data bus for betjening i forbindelse med Beomaster/Beocenter. Data bus for control in connection to Beomaster/Beocenter. | | | | | | |
| 2 3 | I ² C DATA I ² C DATA og CLOCK for system kontrol. I ² C CLOCK I ² C DATA and CLOCK for system control. | »Activity« | »Activity« | »Activity« | »Activity« | »Activity« | |
| 12 | TRAY POSITION Information til 5IC4 om pladeskuffens øjeblikkelige position ved ind og ud transport, hvorefter ben 4, 5, 6, 7 og 8 kan bestemme hastigheden. 4 } TRAY Information to 5IC4 about the instant position of the CD tray when moving in 5 } SPEED or out, 6 } where upon pin 4, 5, 6, 7 and 8 determines the speed. 7 } 8 } | | | | | | |
| 9 | TRAY IN Bestemmer om pladeskuffen skal gå ind eller ud. | | | | | | |
| 10 | TRAY OUT Determines whether the CD tray moves in or out. | | | | | | |
| 20 | TRAY IN Information til 5IC4 om pladeskuffen er inde eller ude. | | | | | | |
| 21 | TRAY OUT Information to 5IC4 whether the CD tray is in or out. | | | | | | |
| 22 | POWER ON/OFF Tænder og slukker strømforsyningerne til servo og signalbehandlingskredsløbene. Switches the power supplies to the servo and signal processing circuits on and off. | | | | | | |
| 24 | ENABLE Enable signal til displayet. Enables the display. | | | | | | |
| 25 | MUTE Muter audio signalet. Mutes the audio signal. | »Low« | »Low« | »Low« | »Low« | »Low« | |

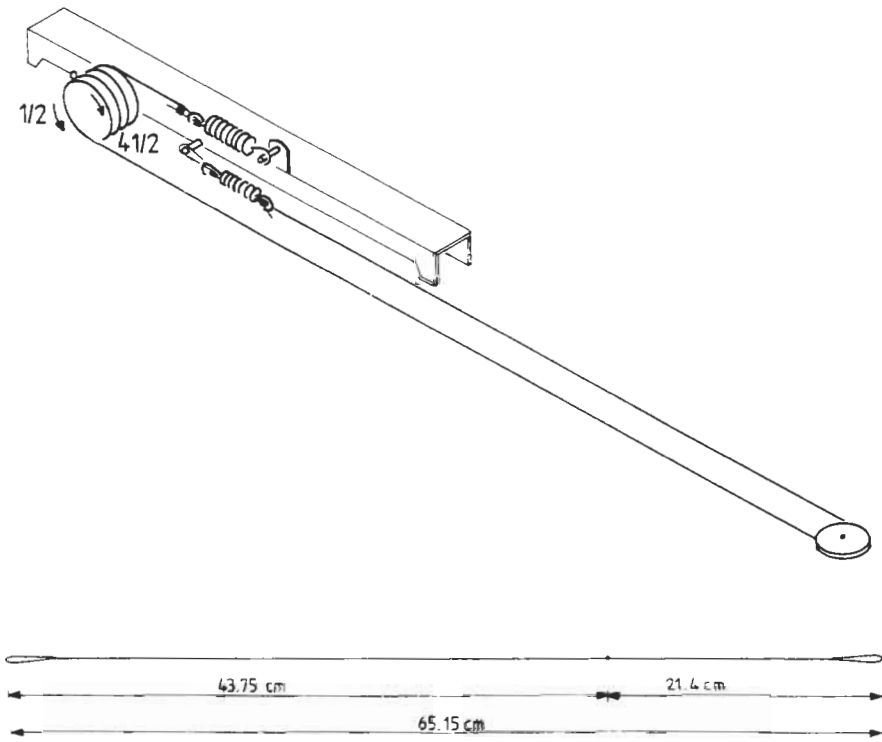

NETSPÆNDINGSVARIANTER AF TRANSFORMATOR 8005169

MAINS VOLTAGES FOR TRANSFORMER 8005169

220 V:

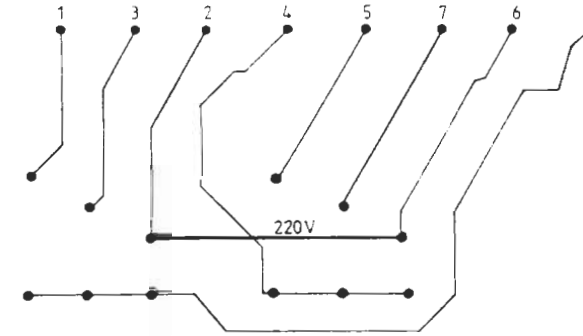

Seen From Copper foil Side

240 V:

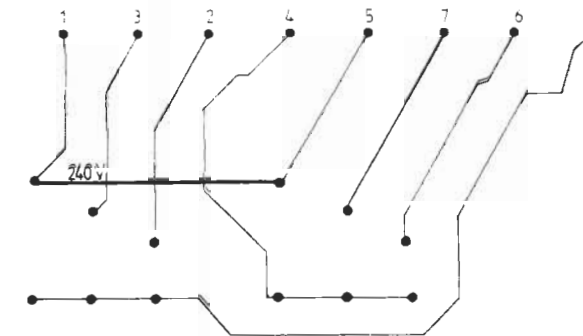

Seen From Copper foil Side

120 V:

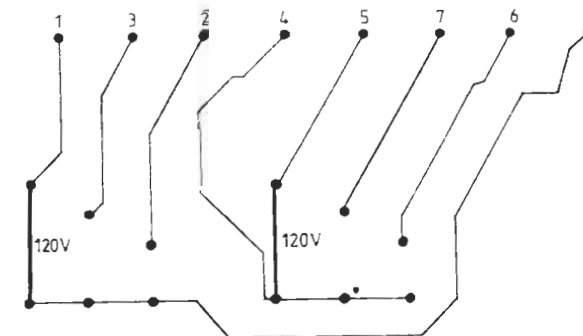

Seen From Copper foil Side

100 V:

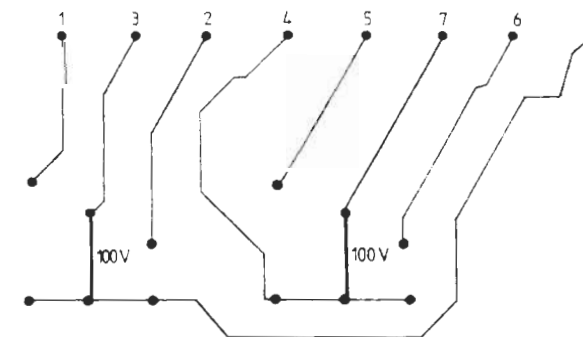

Seen From Copper foil Side

ISOLATIONSTEST

Når et apparat har været skilt ad, *skal* det isolations-testes. Testen skal udføres, efter at apparatet er blevet samlet igen og er klar til levering til kunden.

Isolationstest for Beogram CD5500

Isolationstesten udføres som følger:

Kortslut de to stikben i netstikket og tilslut en af isolationstestapparatets terminaler. Isolationstestapparatets anden terminal tilsluttes stelbenet i en af phono-bøsningerne.

NB!

For at undgå at ødelægge apparatet er det meget vigtigt, at begge isolationstestapparatets terminaler er i virkelig god mekanisk kontakt.

Så drejes isolationstestapparatets spændingsregulator langsomt, indtil man opnår en spænding på 1,5kV. Hold den der i 1 sekund, og skru så langsomt ned for spændingen igen.

Derefter flyttes terminalen fra stelbenet til en skrue i bunden af apparatet.

Så drejes isolationstestapparatets spændingsregulator igen langsomt, indtil man opnår en spænding på 1,5kV. Hold den der i 1 sekund, og skru så langsomt ned for spændingen igen.

Der må på intet tidspunkt i testforløbet forekomme overslag.

INSULATION TEST

Each set *must* be insulation tested after dismantling. The test is to be performed when the set has been re-assembled and is ready for delivery to the customer.

Insulation test for Beogram CD5500

Make the insulation test as follows:

Short-circuit the two plug pins of the mains plug and connect one of the terminals of the insulation tester. Connect the other terminal of the insulation tester to the chassis pin of one of the phono bushings.

NB!

To avoid ruining the set, it is essential that both insulator test terminals are in really good mechanical contact.

Now slowly turn the voltage control of the insulation tester until a voltage of 1.5 kV is obtained. Hold it there for 1 second, and slowly turn down the voltage again.

Now move the terminal from the chassis pin to a screw in the bottom of the set.

Then again slowly turn the voltage control of the insulation tester until a voltage of 1.5 kV is obtained. Hold it there for 1 second, and slowly turn down the voltage again.

At no point during the testing procedure any flash-overs are permissible.

KREDSLØBSBESKRIVELSE

Indledning

Beogram CD 5500 er en nyudviklet Compact Disc af-spiller, der primært er tænkt som en del af Beosystem 5500. Beogram CD 5500 kan naturligvis også tilsluttes og betjenes via Datalink fra andre Bang & Olufsen produkter eller kan tilsluttes forstærkere af andre fabrikater via phonostik.

Beogram CD 5500 er opbygget omkring IC-sættene beskrevet i kredsløbsbeskrivelsen:

Bang & Olufsen Compact Disc
med dekoder IC-sæt SAA 7210
SAA 7220
TDA 1541P
og servo IC-sæt TDA 5708
TDA 5709

Ovennævnte kredsløbsbeskrivelse omhandler dekoder- og servo-kredsløbet. Denne beskrivelse omhandler de øvrige kredsløb i Beogram CD 5500, såsom styring og kontrol, motorkredsløb for CD-skuffe, det analoge filter og digitalt udtag.

Styring/kontrol

Styring af Beogram CD 5500's funktioner foretages af 5IC4 (MAB 8461) og 5IC6 (MAB 8441). 5IC4 varetager den overordnede styring af CD-enheden, hvorimod 5IC6 kontrollerer laserenhedens aftastning af CD-pladen. 5IC6 omtales herefter som servoprocessor.

5IC4 (MAB 8461) er en single-chip 8-bit uC med 6 K ROM/128 RAM bytes og 8-bit LED drive.

5IC6 (MAB 8441) er en single-chip 8-bit uC med 4 K ROM/128 RAM bytes og 8-bit LED drive.

Kommunikationen mellem de to uC'er og display drive IC'en 1IC1 foregår via I²C bus. Servoprocessoren 5IC6 genererer I²C clock pulserne og optræder dermed som master på bussen.

Beogram CD 5500 aktiveres via LINK-forbindelsen fra Beomaster/Beocenter eller via tryk på frontpanelet: PLAY eller EJECT.

Netdelen startes op/afbrydes via 5IC4 ben 22 POWER ON/OFF.

Se benoversigt over 5IC4.

Motorkredsløb for CDskuffe

Den principielle virkemåde

Et nyt motorstyringsprincip for CD-skuffen i Beogram CD 5500 har gjort det muligt at mindske CD-skuffens transporttid væsentligt i forhold til andre kendte CD-pladespillere.

CIRCUIT DESCRIPTION

Introduction

The Beogram CD 5500 is a newly developed Compact Disc player which is primarily intended as a constituent of the Beosystem 5500. Of course, the Beogram CD 5500 may also be connected to and operated via Datalink from other Bang & Olufsen products, or it may be connected to amplifiers of other brands via a phono plug.

The Beogram CD 5500 has been designed around the IC sets described in the circuit description:

Bang & Olufsen Compact Disc
with the decoder IC set SAA 7210
SAA 7220
TDA 1541P
and the servo IC set TDA 5708
TDA 5709

The above-mentioned deals with the decoder and servo circuits. This description deals with the other circuits in the Beogram CD 5500, e.g., control and monitoring, motor circuit for CD tray, the analog filter and digital output.

Control/monitoring

The functions of the Beogram CD 5500 are controlled by 5IC4 (MAB 8461) and 5IC6 (MAB 8441). 5IC4 handles the general control of the CD unit whereas 5IC6 monitors laser unit scanning of the CD. 5IC6 will be termed servo processor below.

5IC4 (MAB 8461) is a single-chip 8-bit uC with 6 K ROM/128 RAM bytes and 8-bit LED drive.

5IC6 (MAB 8441) is a single-chip 8-bit uC with 4 K ROM/128 RAM bytes and 8-bit LED drive.

Communication between the two uC's and the display drive IC 1IC1 is effected via the I²C bus. The servo processor 5IC6 generates the I²C clock pulses and thus behaves as master on the bus.

The Beogram CD 5500 is actuated via the LINK connection from a Beomaster/Beocenter or by pressing PLAY or EJECT on the front panel.

The power-supply unit is switched on/off via 5IC4 pin 22, POWER ON/OFF.

See also pin survey 5IC4 and 5IC5 in section 7, Service Tips.

Motor circuit for CD tray

Principle of operation

A new motor control principle for the CD tray in the Beogram CD 5500 has permitted a significant reduction in CD tray transport time compared to other recognized CD players.

Adgangstiden (tiden fra PLAY er aktiveret til CD-pladen afspilles) er yderligere nedsat, da indføringen af CD-skuffen og fastholdelse af CD-pladen foregår i samme arbejdsproces. Adgangstiden er ca. 5 sek.

Den kortere transporttid er opnået ved at øge CD-skuffens hastighed. For at CD-skuffen ikke skal køre hårdt imod endestop, reduceres hastigheden langsomt under hele transporten.

Fastholdelse af CD-pladen sker mekanisk.

I forbindelse med CD-skuffen er der monteret en lille metalstang, der ved ind-transport af CD-skuffen griber fast i en plastvinkel på CD-løbeværket. Derved »løftes« løbeværket op, og CD-pladen fastholdes.

Ved at motorstyringskredsløbet kontinuerligt får tilbagemelding om CD-skuffens aktuelle hastighed og position, sikres det, at en øget/ændret friktion ingen indflydelse har på CD-skuffens transporthastighed.

Når CD-skuffen er helt åben eller helt lukket (ved endestop) aktiverer skuffen en kontakt (90S1).

Når CD-skuffen er lukket, skal kontakten være aktiveret før Beogram CD 5500 begynder aftastning af pladen. Derudover anvendes aktivering af kontakten som reference for motorstyringskredsløbet.

Opstår der fejl, så kontakten ikke aktiveres, bliver CD-skuffen ført relativt langsomt ind f.eks. hvis CD-skuffen er blokeret i ud-transport. Aktiveres kontakten heller ikke, når skuffen er lukket, forsøger motor-kredsløbet at 'trække' i CD-skuffen igen, hvorefter 'time out' funktionen træder i kraft.

Hvis CD-skuffen er blokeret under ind-transport, kører skuffen lidt ud og derefter forsøger at køre ind igen. Dette gentages, hvorefter CD-skuffen forbliver ude, indtil 'time out' funktionen træder i kraft.

»Time out« funktionen

I motorstyringskredsløbet for CD-skuffen er der indbygget en 'time out' funktion.

Det betyder:

- Når der ikke er fejl på apparatet lukker CD-skuffen automatisk efter 3 min, hvis PLAY ikke er aktiveret forinden.
- Ved fejl forsøger CD-skuffe motorkredsløbet at lukke/trække skuffen ind efter 3 min. Derefter forbliver CD-skuffen ude, og Beogram CD 5500 går i STAND BY.

Access time (the time-lapse from actuation of PLAY till the CD starts playing) has been reduced further because the driving in of the CD tray and clamping of the disc are carried out in one operation. Access time is approx. 5 sec.

The short transport time has been achieved by increasing the speed of the CD tray. The speed is reduced gradually throughout the course of transport in order to avoid the CD tray bumping into the end stop with excessive force.

The disc is clamped mechanically.

A small metal rod is mounted in connection with the CD tray. When the CD tray is driven in, the rod grips a plastic plate on the CD transport mechanism. The transport mechanism is thereby 'lifted', and the disc is clamped.

Continuous feedback to the motor control circuit regarding current speed and position of the CD tray ensures that an increase/change of friction will have no effect on the transport speed of the CD tray.

When the CD tray is completely open or closed (at end stop), the tray actuates a switch (90S1).

When the CD tray is closed, the switch has to be actuated before the Beogram CD 5500 starts scanning the disc. Furthermore, actuation of the switch is used as a reference by the motor control circuit.

If an error occurs which results in the switch not being actuated, the CD tray will be driven in at a relatively low speed, if, for example, the CD tray is blocked while being transported out. Also, if the switch is not actuated when the tray has been closed, the motor circuit tries to 'pull' the CD tray again, and then the 'time-out' function steps in.

If the CD tray is blocked while being driven in, the tray will move out a little and then try to move in again. This is repeated, and then the CD tray remains out until the 'time-out' function steps in.

'Time-out' funktion

A 'time-out' function is incorporated in the motor control circuit for the CD tray.

This means that:

- When there is no error in the product the CD tray will close automatically after 3 minutes unless PLAY is actuated beforehand.
- In case of error, the CD tray motor control circuit will try to close/'pull' in the tray after 3 minutes. Then the CD tray remains out, and the Beogram CD 5500 goes into STAND-BY.

Den elektriske virkemåde

Motorkredsløbet for CD-skuffen består af en D/A-konverter, et forstærkerkredsløb og en optokobler.

Electric operation

The motor circuit for the CD tray comprises a D/A converter, an amplifier circuit and an optocoupler.

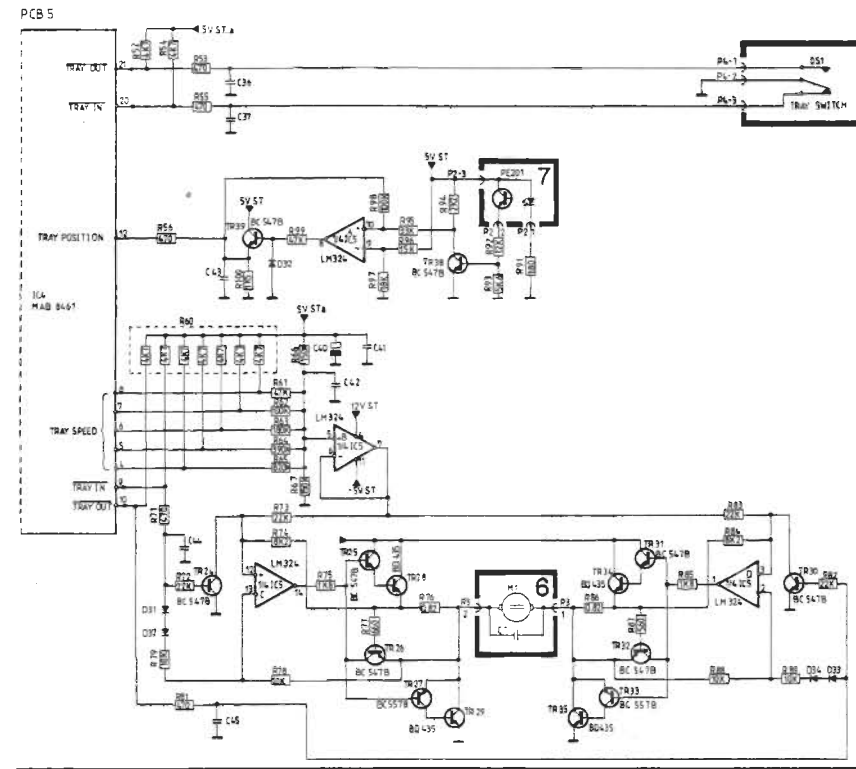

Ved hjælp af D/A-konverteren (dannet af 5R6165 og 5IC5b) styrer 5IC4 CD-skuffemotorens hastighed. Niveaueet på ben 9 og 10 af 5IC4 angiver CD-skuffens retning.

5IC4 controls the CD tray motor's speed by means of the D/A converter (formed by 5R6165 and 5IC5b). The level at pins 9 and 10 of 5IC4 determines the transport direction of the CD tray.

Motorstyringskredsløbet får tilbagemeldingen fra optokobleren 7PE201.

The motor control circuit receives feedback from the optocoupler 7PE201.

Optokobleren 7PE201's opgave er at informere 5IC4 om CD-skuffens aktuelle hastighed og position under transport.

The optocoupler, 7PE201, has to provide 5IC4 with information on the current speed and position of the CD tray during transport.

Lyset i optokobleren brydes af en tacho-skive. Tachoskiven er er støbt sammen med en remskive og et snorhjul.

The light in the optocoupler is broken by a tacho disc. The tacho disc is cast together with a belt pulley and a cord pulley.

Remskiven drejes af CD-skuffemotoren. Omkring snorhjulet er der viklet en nylon snor, hvis ender er fæstnet til CD-skuffen.

The belt pulley is driven by the CD tray motor. A nylon cord with the ends tied to the CD tray is wrapped around the cord pulley.

Tacho-skiven drejer derfor i takt med CD-skuffens bevægelse.

Consequently, the tacho disc rotates in line with the movement of the CD tray.

Ved at 'tælle' impulserne er 5IC4 istand til at beregne CD-skuffens aktuelle hastighed og position. Derved kan 5IC4 tilpasse skuffemotorens hastighed i forhold til CD-skuffens position. Fra endestop til endestop modtager 5IC4 ca. 80 pulser fra optokobleren.

By 'counting' the pulses, 5IC4 is able to calculate the current speed and position of the CD tray. 5IC4 can thus adapt tray motor speed relative to the position of the CD tray. 5IC4 receives approx. 80 pulses from the optocoupler from end stop to end stop.

90S1 aktiveres af CD-skuffen, når skuffen er helt åben eller helt lukket (endestop). Kontakten sluttes normalt ca. 3 sek., efter at PLAY eller EJECT er aktiveret.

90S1 is actuated by the CD tray when the latter is completely open or closed (end stop). The contact is made approx. 3 seconds after PLAY or EJECT has been actuated.

5IC4 kalkulerer med et vist antal impulser fra optokobleren indenfor en bestemt tid. Hvis det forhold ændrer sig væsentligt opfatter 5IC4, at der er fejl i CD-skuffetransporten, og CD-skuffen bliver kørt langsomt ind som omtalt under 'den principielle virkemåde'.

5IC4 expects a certain number of pulses from the optocoupler within a certain period. If that number changes significantly, 5IC4 interprets this as an error in the CD tray transport, and the CD tray is driven in slowly as mentioned under "principles of operation".

Det analoge filter

Det analoge filter er et nyudviklet 3.-ordens Bessel-filter med nulpunkt ved 156.4 kHz. Nulpunktet dannes af et elliptisk filter. Det analoge filter er opbygget uden brug af spoler, hvilket giver en meget lav forvrængning.

The analog filter

The analog filter is a newly-developed 3rd-order Bessel filter with the neutral point at 156.4 kHz. The neutral point is formed by an elliptic filter. The analog filter has been designed without using coils, which results in very low distortion.

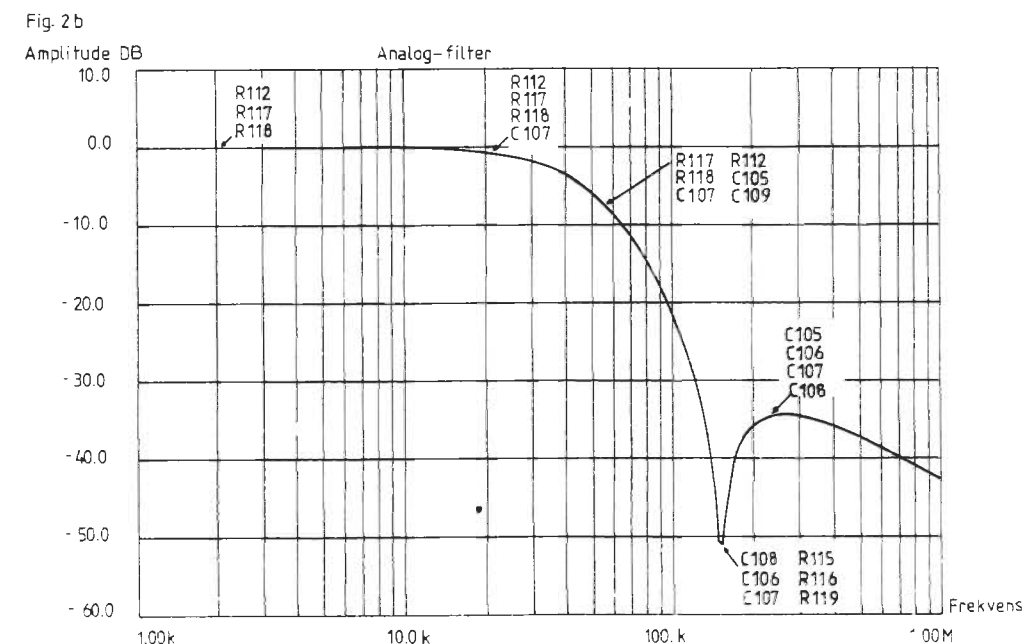
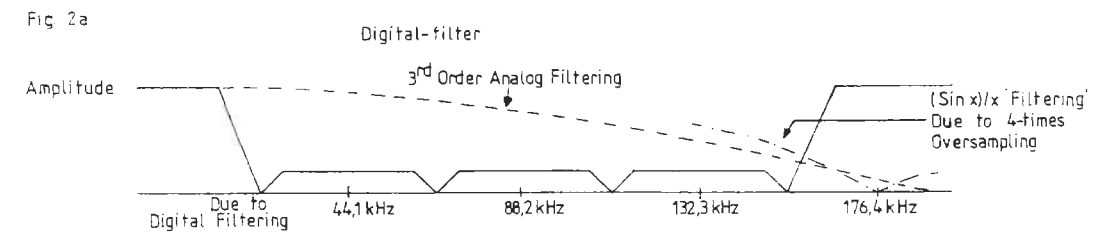

Figur 2a viser det digitale filters og et 3.-ordens Bessel-filters indvirkning på frekvenskarakteristikken.

Fig. 2a shows the frequency characteristic from the digital filter and a 3rd-order Bessel filter's influence on the characteristic.

Figur 2b viser frekvenskarakteristikken for det analoge filter med nulpunkt med indikering af de enkelte komponenters arbejdsområde.

Figure 2b shows the frequency characteristic for the analog filter with neutral point, indicating the operating range of the individual components.

Den analoge signaldel og den digitale signaldel forsynes fra hver deres netdel. Derved elimineres risikoen for at overføre støj til den analoge signaldel via forsyningsspændingen.

The analog signal section and the digital signal section are supplied from independent power-supply units. This eliminates the risk of transferring noise to the analog signal section via the supply voltage.

Digitalt udtag

Fra Beogram CD 5500 kan signalet udtages via phono-bøsningen D-OUT i digital form. Signalet tages fra 5IC9 (SAA 7220) ben 14. 5IC9 og D-OUT bøsningen er galvanisk adskilt. Det digitale signal indeholder foruden det fejlkorrigerede og filtrede audiosignal også subkode-informationer.

Signalet er beregnet for fremtidigt digitalt udstyr, der kan anvende eventuelle supplerende data på CD-plader. F.eks. til at vise tekst og grafik på en skærm eller til optagelse af CD-plader på en digital båndoptager.

Digital output

From the Beogram CD 5500 the signal can be delivered via the phono bush D-OUT in digital form. The signal is obtained from 5IC9 (SAA 7220) pin 14. 5IC9 and the D-OUT bush are galvanically separated. The digital signal contains subcode information in addition to the error corrected and filtered audio signal.

This signal is intended for future digital equipment capable of utilizing any possible supplementary data on CD's. For example, for displaying text and graphics on a screen or for recording CD's on a digital tape recorder

**Diagram, PCB drawing and
partlist for servo PCB30 without
focus off-set adjustment**

DIAGRAM A (Servo and Disc Motor System)

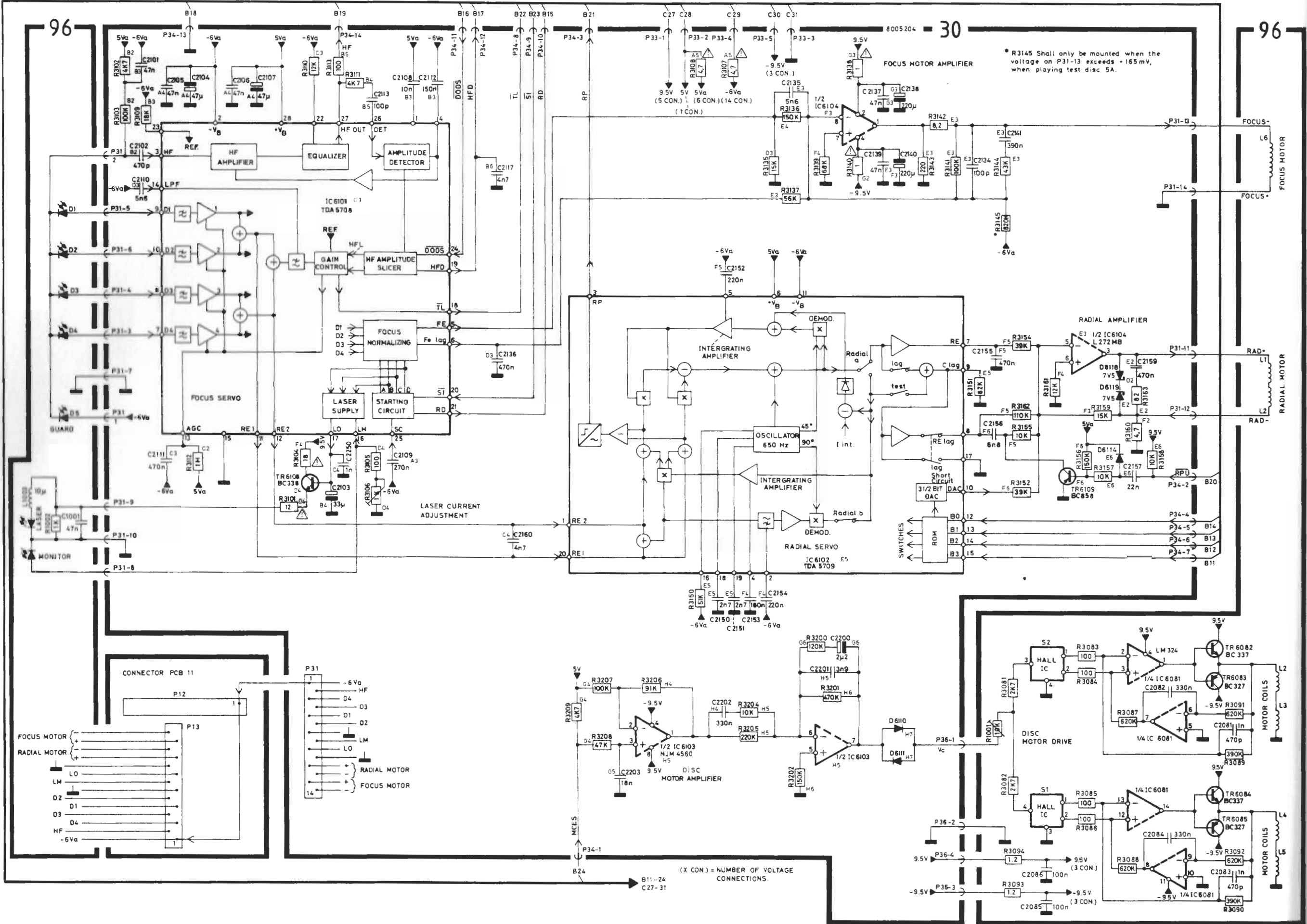

SERVO PCB 30

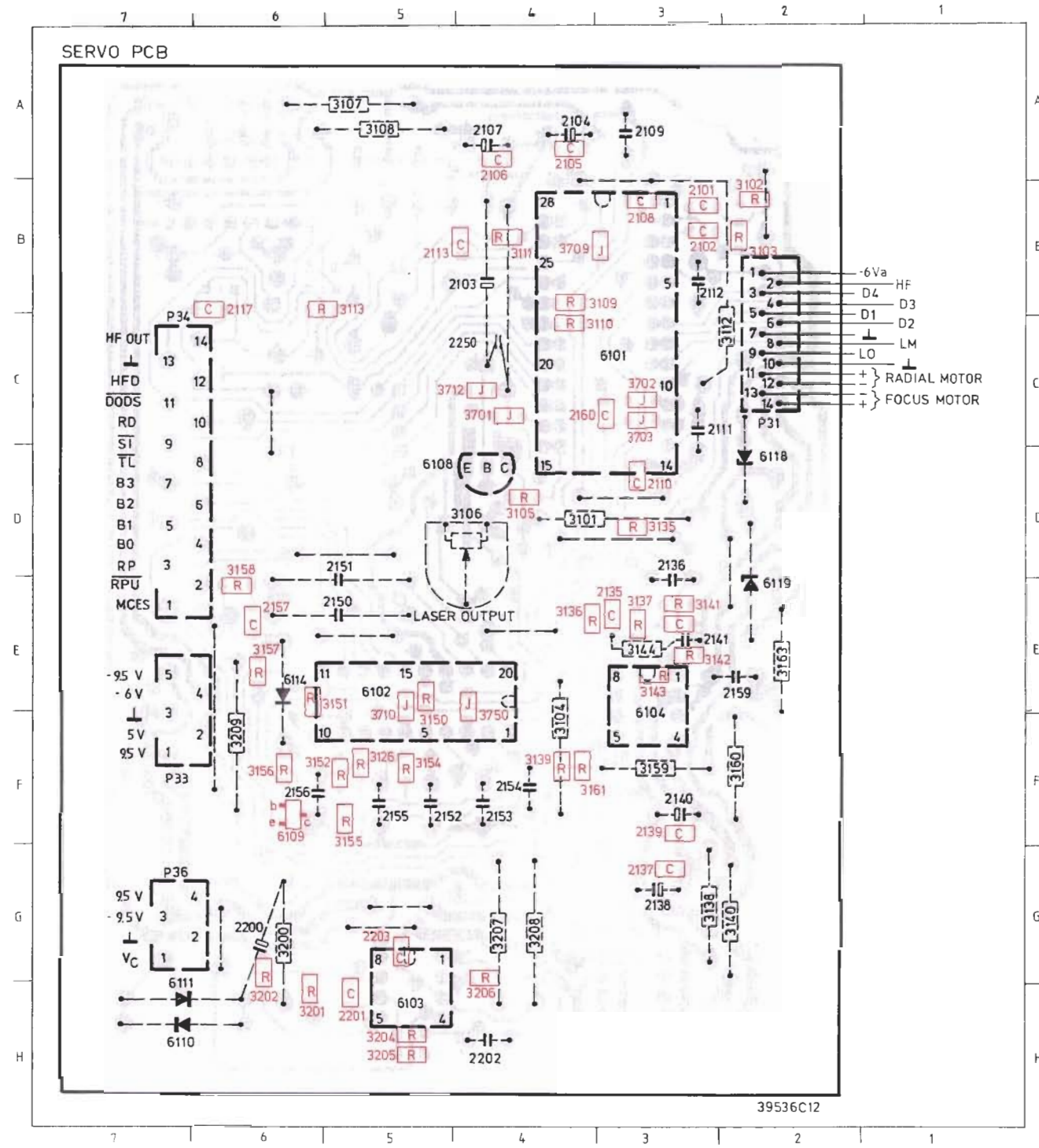

DISC MOTOR CONTROL

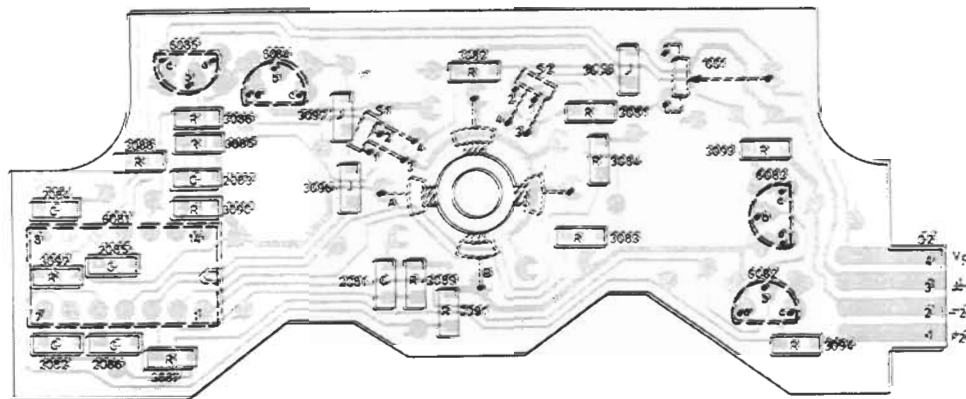

SERVO PCB 30

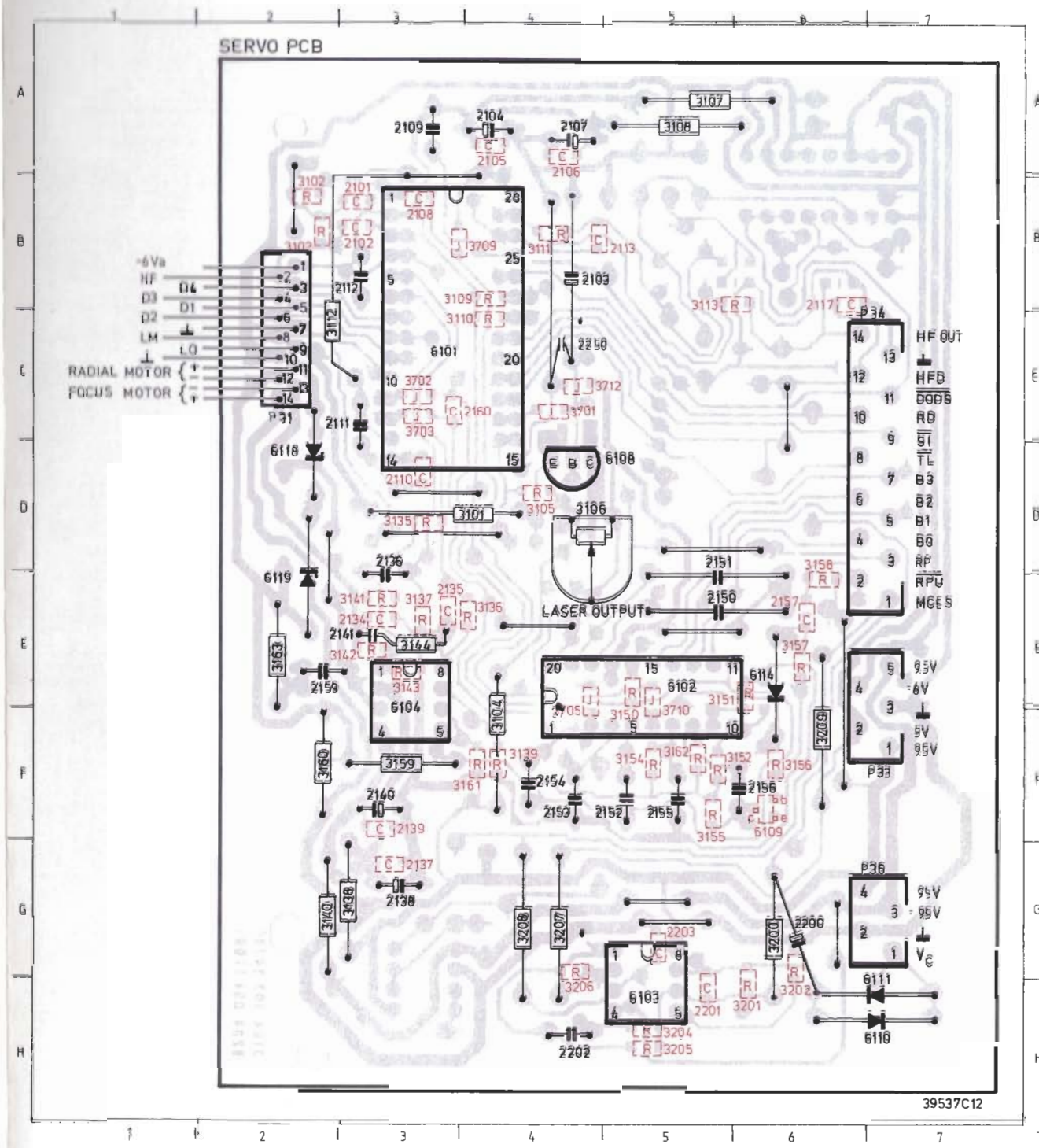

DISC MOTOR CONTROL

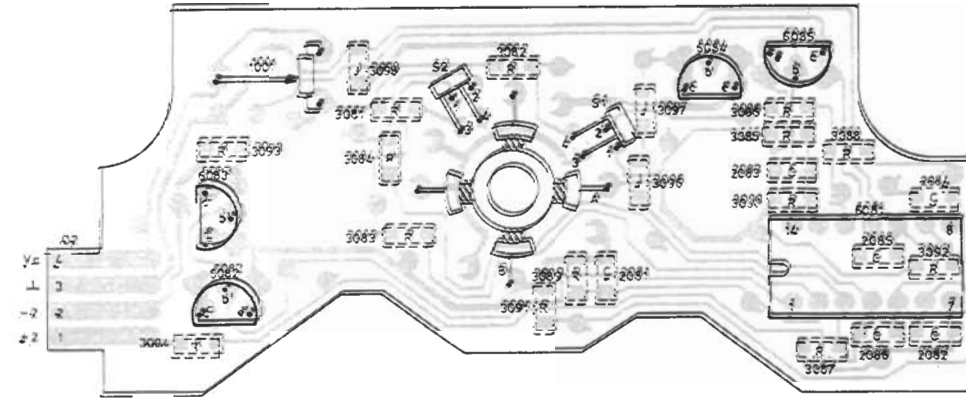

LIST OF ELECTRICAL PARTS

PCB 30, 8005204
Servo



| | | | | | | | |
|---------|---------|-----------------------|-------------|--------|---------|-------------------------|------------|
| IC6101Δ | 8340991 | 125 | TDA 5708 C3 | IC6103 | 8340993 | 103 | NJM 4560D |
| IC6102Δ | 8340992 | 134 | TDA 5709 | IC6104 | 8340605 | 103 | L 272MH |
| TR6108 | 8320721 | 020 | BC 338-16 | TR6109 | 8320616 | 051 | BC 858 B |
| D6110- | 8300058 | 209 | 1N 4148 | D6118- | 8300570 | 209 | HZ 7C2 7V5 |
| D6111 | | | | D6119 | | | |
| D6114 | 8300058 | 209 | 1N 4148 | | | | |
| R3101 | 5020966 | 12 Ω | 5% | R3150 | 5011493 | 51 kΩ | 2% 1/8W |
| R3102 | 5011234 | 4.7 kΩ | 2% 1/8W | R3151 | 5011254 | 82 kΩ | 2% 1/8W |
| R3103 | 5011256 | 100 kΩ | 2% 1/8W | R3154 | 5011491 | 39 kΩ | 2% 1/8W |
| R3104 | 5020967 | 18 Ω | 5% | R3155 | 5011241 | 10 kΩ | 2% 1/8W |
| R3105 | 5011218 | 100 Ω | 2% 1/8W | R3156 | 5011494 | 150 kΩ | 5% |
| R3106 | 5370355 | 1 kΩ | 20% | R3157- | 5011241 | 10 kΩ | 2% 1/8W |
| R3107- | 5020965 | 4.7 Ω | 2% 1/3W | R3158 | | | |
| R3108 | | | | R3159 | 5020074 | 15 kΩ | 1% 1/4W |
| R3109 | 5011244 | 18 kΩ | 2% 1/8W | R3160 | 5020971 | 4.7 Ω | 1% 1/4W |
| R3110 | 5011490 | 12 kΩ | 2% 1/8W | R3161 | 5011490 | 12 kΩ | 2% 1/8W |
| R3111 | 5011234 | 4.7 kΩ | 2% 1/8W | R3162 | 5011504 | 110 kΩ | 2% |
| R3112 | 5020288 | 1 MΩ | 1% 1/4W | R3163 | 5010056 | 82 Ω | 5% 1/4W |
| R3113 | 5011218 | 100 Ω | 2% 1/8W | R3200 | 5020062 | 120 kΩ | 5% 1/4W |
| R3135 | 5011243 | 15 kΩ | 2% 1/8W | R3201 | 5011265 | 470 kΩ | 2% 1/8W |
| R3136 | 5011259 | 150 kΩ | 2% 1/8W | R3202 | 5011494 | 150 kΩ | 5% |
| R3137 | 5011251 | 56 kΩ | 2% 1/8W | R3204 | 5011241 | 10 kΩ | 2% 1/8W |
| R3138 | 5020964 | 1.0 Ω | 2% 1/3W | R3205 | 5011261 | 220 kΩ | 2% 1/8W |
| R3139 | 5011252 | 68 kΩ | 2% 1/8W | R3206 | 5011255 | 91 kΩ | 2% 1/8W |
| R3140 | 5020964 | 1.0 Ω | 2% 1/3W | R3207 | 5020263 | 100 kΩ | 1% 1/4W |
| R3141 | 5011256 | 100 kΩ | 2% 1/8W | R3208 | 5020969 | 47 kΩ | 1% 1/4W |
| R3144 | 5020968 | 43 kΩ | 1% 1/4W | R3209 | 5020049 | 4.7 kΩ | 1% 1/2W |
| R3145 | 5011528 | 820 kΩ | 5% 1/8W | | | | |
| C2101 | 4010192 | 47 nF | 10% 50V | C2139 | 4010192 | 47 nF | 10% 50V |
| C2102 | 4000249 | 470 pF | 5% 50V | C2140 | 4200745 | 220 μF | 16V |
| C2103 | 4200414 | 33 μF | -10+50% 16V | C2141 | 4130407 | 390 nF | 10% 63V |
| C2104 | 4200482 | 47 μF | 20% 10V | C2150- | 4130416 | 2.7 nF | 1% 250V |
| C2105- | 4010192 | 47 nF | 10% 50V | C2151 | | | |
| C2106 | | | | C2152 | 4130206 | 220 nF | 10% 100V |
| C2107 | 4200482 | 47 μF | 20% 10V | C2153 | 4130314 | 180 nF | 10% 50V |
| C2108 | 4000254 | 10 nF | 10% 50V | C2154 | 4130206 | 220 nF | 10% 100V |
| C2109 | 4130379 | 270 nF | 5% 63V | C2155 | 4130293 | 470 nF | 10% 50V |
| C2110 | 4000253 | 5.6 nF | 10% 50V | C2156 | 4130338 | 6.8 nF | 5% 100V |
| C2111 | 4130405 | 470 nF | 5% 50V | C2157 | 4000255 | 22 nF | 10% 50V |
| C2112 | 4130406 | 150 nF | 5% 50V | C2159 | 4130293 | 470 nF | 10% 63V |
| C2113 | 4000248 | 100 pF | 5% 50V | C2160 | 4010173 | 4.7 nF | 10% 50V |
| C2117 | 4010173 | 4.7 nF | 10% 50V | C2200 | 4200740 | 2.2 μF | 25V |
| C2134 | 4000248 | 100 pF | 5% 50V | C2201 | 4010202 | 3.9 nF | 10% |
| C2135 | 4000253 | 5.6 nF | 10% 50V | C2202 | 4130217 | 330 nF | 5% 63V |
| C2136 | 4130405 | 470 nF | 5% 50V | C2203 | 4130410 | 18 nF | 10% |
| C2137 | 4010192 | 47 nF | 10% 50V | C2250 | 4010035 | 1 nF | 10% 63V |
| C2138 | 4200745 | 220 μF | 16V | | | | |
| P31 | 7210614 | Socket 14 pol | | P34 | 7220657 | Plug 14 pol | |
| P33 | 7220652 | Plug 5 pol | | P36 | 7220651 | Plug 4 pol | |
| To P5 | 6275746 | Wire w/sokets 5/5 pin | | To P6 | 6275745 | Wire w/sokets 14/14 pin | |

Δ betyder at statisk elektricitet kan ødelægge komponenten.
 Δ indicates that static electricity may destroy the component.
 Δ bedeutet, daß statische Elektrizität die Komponente zerstören kann.
 Δ signifi que électricité statique peut detruire le composant.

- Speciel udvalgt eller bearbejdet eksemplar.
- Specially selected or adapted sample.
- Speziell ausgewähltes und bearbeitets Exemplar.
- Exempleire, spécialement sélectionné et façonné.

Beogram CD 5500

Nyt CD-løbeværk

New CD drive mechanism

Fra apparat nr. 05858372 er CD-løbeværket ændret fra en type CDM2 til en type CDM4

Ved udskiftning af et CDM2- til et CDM4-løbeværk skal løbeværket og servoprintet udskiftes som en samlet enhed (bestillingsnr. 8420158).

- CD-løbeværk, separat Bestillingsnr. 8420159
- Servoprint, separat Bestillingsnr. 8005264

Laserstrøm og fokus off-set *skal* justeres efter udskiftning af CD-løbeværk eller servoprint.

Servoprintet på et CDM4-løbeværk er ændret på følgende punkter:

| | Ny værdi | Bestillingsnr. |
|-------|--------------------------|----------------|
| R3106 | 4,7 k Ω (trimmer) | 5370058 |
| R3143 | 22 Ω | 5011655 |
| R3145 | 680 k Ω | 5011704 |
| R3155 | 8,2 k Ω | 5011240 |
| R3159 | 15 k Ω | 5010053 |
| R3162 | 91 k Ω | 5011255 |
| R3163 | 15 k Ω | 5010468 |
| C2159 | 1,5 μ F (bipolar) | 4200746 |
| C2141 | 470 nF | 4130405 |

- Der er monteret en modstand (R3214, 220k, bestillingsnr. 5011369) fra ben 6 på IC6103 til ben 21 på IC6101.
- Der er monteret en kondensator (C2143, 1,2 nF, bestillingsnr. 4100283) fra ben 1 på IC6104 til ben 5 på IC6101.

Laserstrøm

Vigtigt:

Efter udskiftning af CD løbeværket eller servo-PCB30 skal laserstrøm-potentiometeret 30R3106 forjusteres, inden apparatet tilsluttes lysnettet.

Tilslut et ohmmeter over 30R3105 + 30R3106. Juster 30R3106, indtil 30R3105 og 30R3106 tilsammen har en værdi på 1 k Ω .

Tilslut et DC-voltmeter over 30R3102.

Tilslut et oscilloskop til ben 27 på 30IC6101.

Ilæg testplade nr. 5 (plade uden fejl, bestillingsnr. 3634031) og tryk PLAY.

Kontroller på oscilloskopet, om der er HF signal. Hvis der ikke er HF signal, slukkes apparatet, og fejlen findes.

Hvis der er HF signal, spilles spor 1 på testplade 5, og 30R3106 justeres, til der måles 50mV \pm 5mV med DC-voltmeteret.

From unit no. 05858372 the CD drive mechanism has been changed from a CDM2 model to a CDM4 model.

When replacing a CDM2 model with a CDM4 model the drive mechanism and the servo PCB are to be replaced as a single unit (part no. 8420158).

- CD drive mechanism, separate Part no. 8420159
- Servo PCB, separate Part no. 8005264

The laser current and focus off-set *must* be adjusted after the CD drive mechanism or servo PCB has been replaced.

The servo PCB of the CDM4 drive mechanism has the following modifications:

| | New value | Part no. |
|-------|--------------------------|----------|
| R3105 | 4.7 k Ω (trimmer) | 5370058 |
| R3142 | 22 Ω | 5011655 |
| R3145 | 680 k Ω | 5011704 |
| R3155 | 8.2 k Ω | 5011240 |
| R3159 | 15 k Ω | 5010053 |
| R3162 | 91 k Ω | 5011255 |
| R3163 | 15 k Ω | 5010468 |
| C2159 | 1.5 μ F (bipolar) | 4200746 |
| C2141 | 470 nF | 4130405 |

- A resistor (R3214, 220k, part no. 5011369) is mounted between pin 6 on IC6103 and pin 21 on IC6101.
- A capacitor (C2143, 1,2 nF, part no. 4100283) is mounted between pin 1 on IC6104 and pin 5 on IC6101.

Laser current

Important:

When replacing the CD mechanism or the servo PCB30, the laser current potentiometer 30R3106 must be preadjusted before the set is connected to mains.

Connect an ohmmeter across 30R3105 + 30R3106. Adjust 30R3106 until the combined value of 30R3105 and 30R3106 is 1 k Ω .

Connect a DC voltmeter across 30R3102.

Connect an oscilloscope to pin 27 of 30IC6101.

Load test disc no. 5 (disc without faults, part no. 3634031) and press PLAY.

Check on the oscilloscope whether there is any HF signal. If not, switch off the CD player and locate the fault.

If there is an HF signal, play track 1 of test disc 5 and adjust 30R3106 until a reading of 50 mV \pm 5 mV is obtained on the DC voltmeter.

Fokus off-set
Se side 5-5.

Focus off-set
See page 5-5.

List of Mechanical Parts

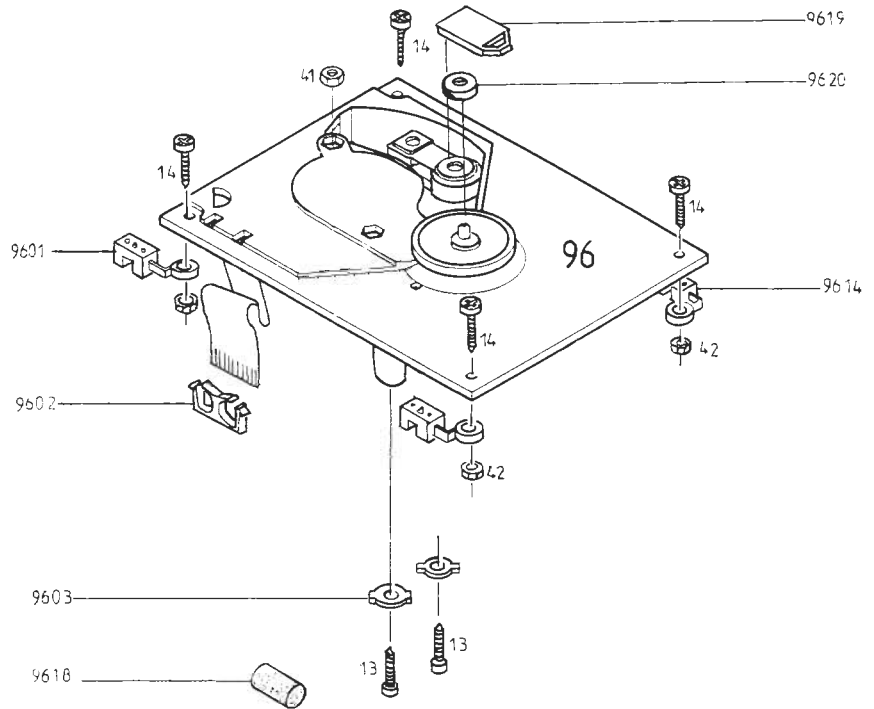

30Modul 8005264 Servo PCB

96Modul 8420158 CD Mechanism and Servo PCB as a kit

96Modul 8420159 CD Mechanism without Servo PCB

8420176

| | |
|------|---------------------------------|
| 9601 | 3333016 Rubber holders |
| 9602 | 3152593 Clamp f. flexible print |
| 9603 | 3034077 Transport screw |
| 9614 | 3333015 Rubber holders |
| 9618 | 3333017 Rubber foam |
| 9619 | 3164797 Cover |
| 9620 | 2893000 Hub |

Survey of screws

| | |
|----|-----------------------|
| 13 | 3013145 Screw 3x12 mm |
| 14 | 2034064 Screw 2x10 mm |
| 41 | 2380012 Nut M3 |
| 42 | 2380147 Nut |

Bang & Olufsen

**CD-Mechanism
Version II
Beogram CD 7000**

Bang & Olufsen

DIAGRAM A (Servo and Disc Motor System)

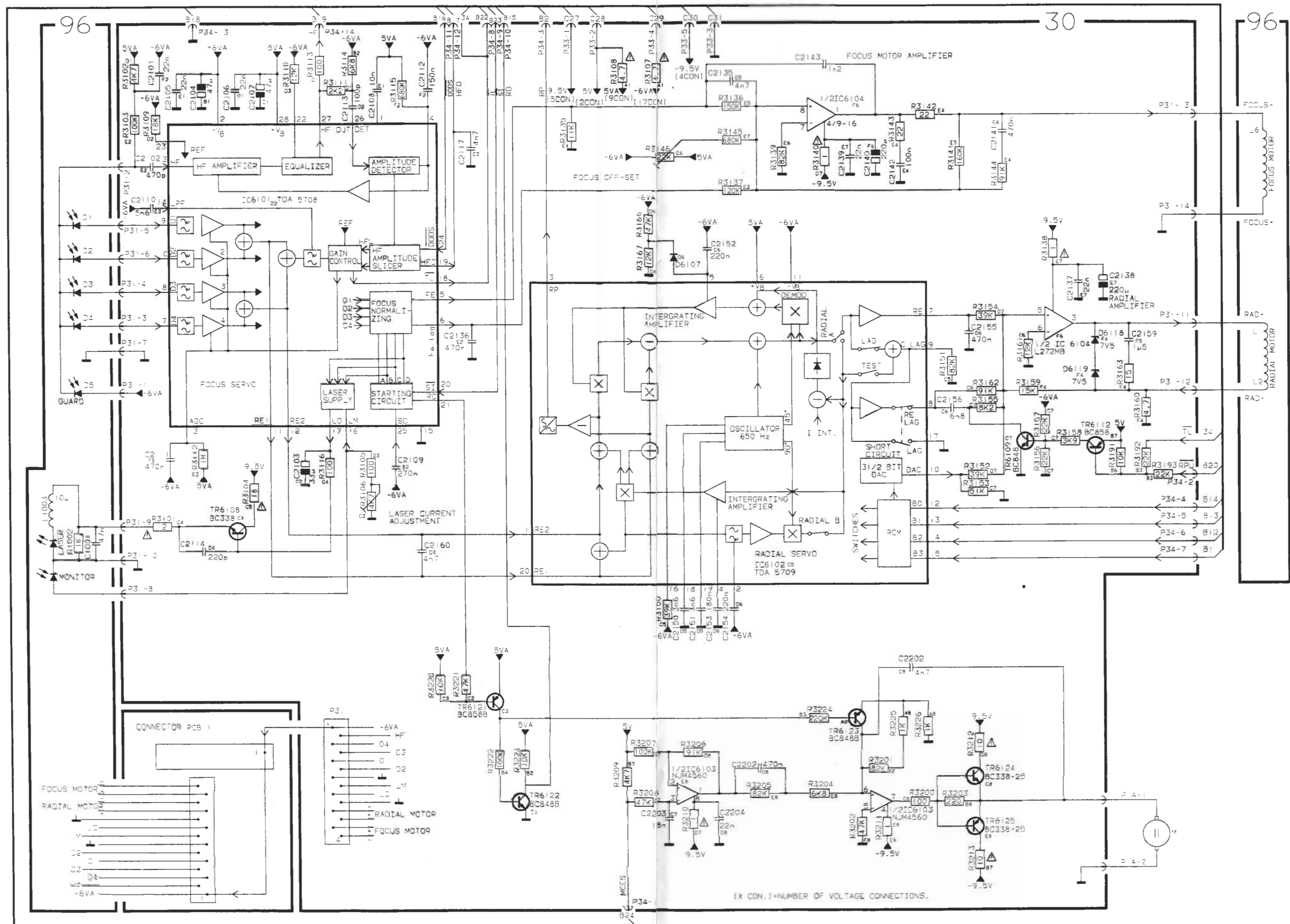

Servo PCB 30

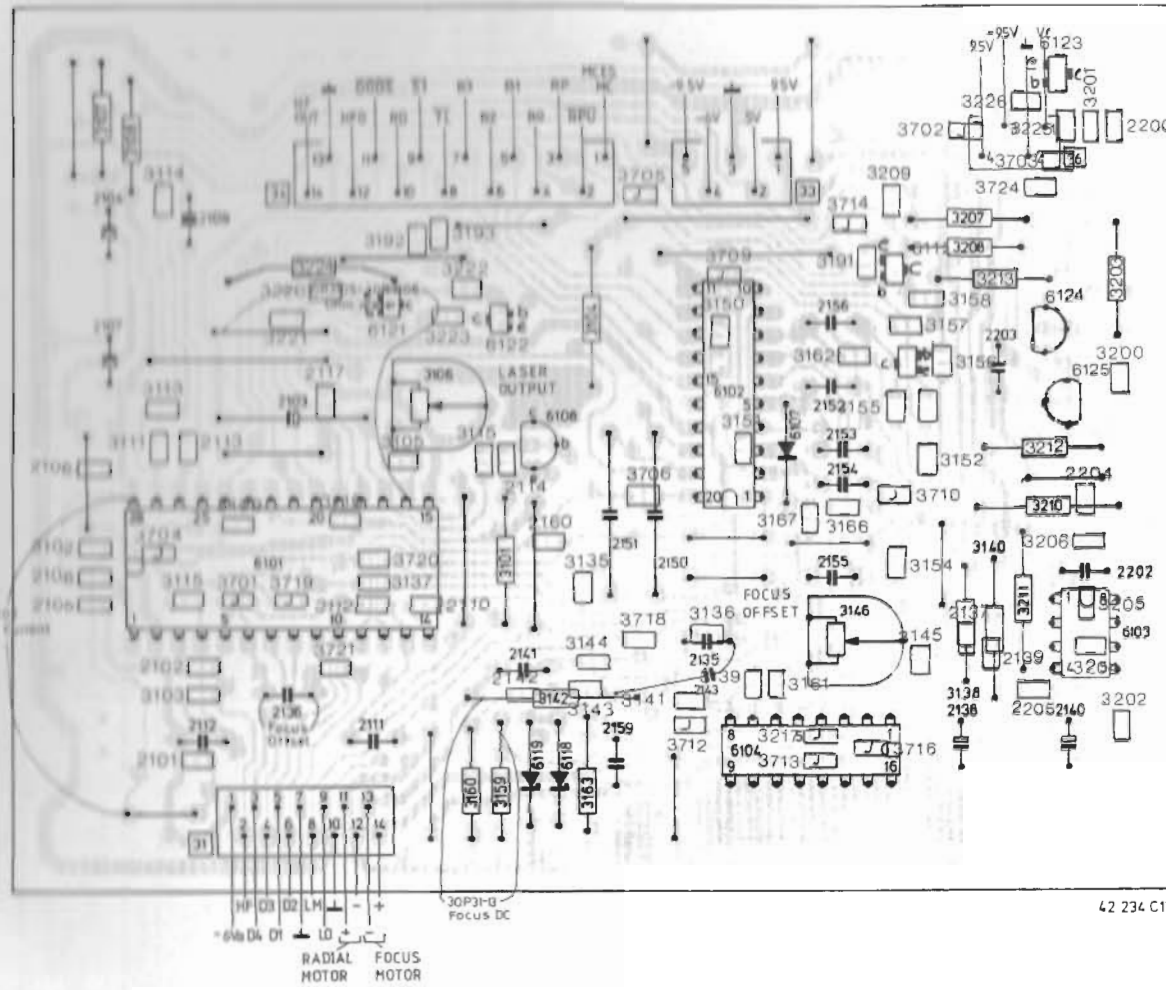

42 234 C12

LIST OF ELECTRICAL PARTS

PCB 30, 8005288 Servo

| 20 | 51 | 103 | 125 | 134 | 209 | | |
|----|----|-----|-----|-----|-----|--|--|
| | | | | | | | |

Δ indicates that static electricity may destroy the component.

Resistors not referred to are standard, see page 3-2

| | | | | | | | |
|---------|---------|-----|-------------|--------|---------|-----|-----------|
| IC6101Δ | 8340991 | 125 | TDA 5708 C3 | IC6103 | 8340993 | 103 | NJM 4560D |
| IC6102Δ | 8340992 | 134 | TDA 5709 | IC6104 | 8340683 | 103 | L 272BH |

| | | | | | | | |
|--------|---------|----|-----------|---------|---------|----|-----------|
| TR6108 | 8320721 | 20 | BC 338-16 | TR6122- | 8320615 | 51 | BC 848B |
| TR6109 | 8320615 | 51 | BC 848B | TR6123 | | | |
| TR6112 | 8320616 | 51 | BC 858B | TR6125 | 8320523 | 20 | BC 328-25 |
| TR6121 | 8320616 | 51 | BC 858B | | | | |

| | | | | | | | |
|-------|---------|-----|---------|--------|---------|-----|------------|
| D6107 | 8300058 | 209 | 1N 4148 | D6118- | 8300570 | 209 | HZ 7C2 7V5 |
| | | | | D6119 | | | |

| | | | | | | | |
|--------|---------|-------|----------|--------|---------|-------|-----------|
| R3101 | 5020966 | 12Ω | 5% 1/3W | R3146 | 5370327 | 22kΩ | 20% 0.1W |
| R3104 | 5020967 | 18Ω | 5% 1/3W | R3160 | 5020971 | 4.7Ω | 1% 1/4W |
| R3106 | 5370324 | 4.7kΩ | 20% 0.1W | R3207 | 5020263 | 100kΩ | 1% 1/4W |
| R3107- | 5020965 | 4.7Ω | 2% 1/3W | R3208 | 5020969 | 47kΩ | 1% 1/4W |
| R3108 | | | | R3210- | 5020964 | 1.0Ω | 2% 1/3W |
| R3138 | 5020964 | 1.0Ω | 2% 1/3W | R3211 | | | |
| R3140 | 5020964 | 1.0Ω | 2% 1/3W | R3212- | 5020489 | 10Ω | 10% 0.30W |
| R3141 | 5011587 | 160kΩ | 1% 1/8W | R3213 | | | |

| | | | | | | | |
|--------|---------|-------|-------------|--------|---------|-------|-------------|
| C2101 | 4000255 | 22nF | 10% 50V | C2139 | 4000255 | 22nF | 10% 50V |
| C2102 | 4000249 | 470pF | 5% 50V | C2140 | 4200745 | 220μ | 16V |
| C2103 | 4200414 | 33μ | -10+50% 16V | C2141 | 4130405 | 470nF | 50V |
| C2104 | 4200482 | 47μ | 20% 10V | C2142 | 4000256 | 100nF | 10% 50V |
| C2105- | 4000255 | 22nF | 10% 50V | C2143 | 4100283 | 1.2nF | 2% 250V |
| C2106 | | | | C2150- | 4130424 | 3.6nF | 1% 160V |
| C2107 | 4200482 | 47μ | 20% 10V | C2151 | | | |
| C2108 | 4000254 | 10nF | 10% 50V | C2152 | 4130206 | 220nF | 10% 100V |
| C2109 | 4130379 | 270nF | 5% 63V | C2153 | 4130314 | 180nF | 10% 63V |
| C2110 | 4000253 | 5.6nF | 10% 50V | C2154 | 4130206 | 220nF | 10% 100V |
| C2111 | 4130405 | 470nF | 10% 50V | C2155 | 4130405 | 470nF | 10% 50V |
| C2112 | 4130406 | 150nF | 5% 50V | C2156 | 4130338 | 6.8nF | 5% 100V |
| C2113 | 4000248 | 100pF | 5% 50V | C2159 | 4200746 | 1.5μ | 50V Bipolar |
| C2114 | 4000233 | 220pF | 5% 50V | C2160 | 4010173 | 4.7nF | 10% 50V |
| C2117 | 4010173 | 4.7nF | 10% 50V | C2200 | 4010173 | 4.7nF | 10% 50V |
| C2135 | 4130370 | 4.7nF | 5% | C2202 | 4130405 | 470nF | 10% 50V |
| C2136 | 4130405 | 470nF | 10% 50V | C2203 | 4130221 | 18nF | 5% 63V |
| C2137 | 4000255 | 22nF | 10% 50V | C2204- | 4000255 | 22nF | 10% 50V |
| C2138 | 4200745 | 220μ | 16V | C2205 | | | |

| | | | | | |
|-----|---------|----------------|-----|---------|---------------|
| P31 | 7210614 | Socket, 14 pol | P34 | 7220657 | Plug, 14 pole |
| P33 | 7220652 | Plug, 5 pole | P36 | 7220651 | Plug, 4 pole |

| | | |
|-------|---------|--------------------------|
| To P5 | 6275746 | Wire w/sockets 5/5 pin |
| To P6 | 6275745 | Wire w/sockets 14/14 pin |

| | |
|---------|----------------------------|
| 8420176 | CD Mechanism with servo |
| 8420177 | CD Mechanism without servo |
| 8005288 | Servo PCB |

6276561 Wire bundle