

# BeoLab 1

Type 6841, 6842, 6843, 6844, 6845, 6846

Service Center repair guide

English, German, French, Italian, Spanish

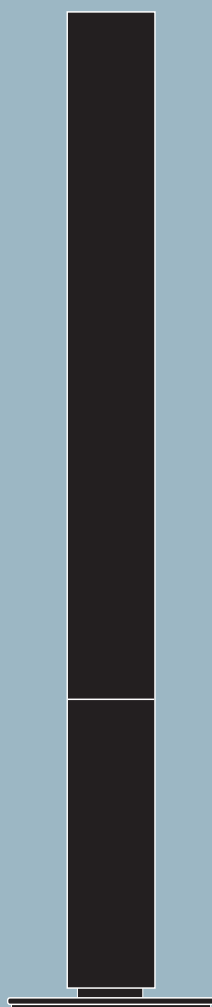

## **CONTENS**

### **How to service.....1**

	English	German	French	Italian	Spanish
How to service	1-1	1-2	1-3	1-4	1-5
Type survey	1-1	1-2	1-3	1-4	1-5
Specification guidelines for service use.....					1-6

### **Brief operation guide.....2**

### **Wiring diagram (not BeoLab 1).....3**

### **List of available parts and exploded view..... 4**

Available documentation.....	4-3
------------------------------	-----

### **Adjustments and repair tips .....5**

English	German	French	Italian	Spanish
5-1	5-1	5-1	5-2	5-2

### **Disassembly.....6**

English	German	French	Italian	Spanish
6-1	6-1	6-1	6-5	6-5

### **After repair tips..... 7**

English	German	French	Italian	Spanish
7-1	7-1	7-1	7-2	7-2

**HOW TO SERVICE****Front line service**

BeoLab 1 must be serviced in the consumers home in terms of electrical symptoms or exchange of mechanical parts as front frame, front cover, cabinet or foot. In this way you avoid having to transport the long and heavy loudspeaker (184cm/36kg) from and back to the consumer. For front line service we offer a back-up suitcase (same principle as for the BeoVision's). All needed electrical parts are found in the back-up suitcase. Mechanical parts (front frame, front cover, cabinet or foot) must be ordered separately.

**Service documentation**

Service Documentation for the BeoLab 1 will be a "On-Site service guide" and this "Service Center repair guide" with part no. for the back-up suitcase, mechanical parts and User's Guide.

**TYPE SURVEY****Converting mains voltage supply**

If it is necessary to change voltage supply, e.g. when moving between two countries, it is necessary to order two back-up suitcases for the type sold in the specific new country (one for each loudspeaker).  
E.g.: Moving from EU (type 6841) to Japan (type 6844); order two Back-up suitcases for type 6844, order no. : 3395147.

<b>Type number</b>	<b>Order no.</b>	<b>Mains voltage</b>	<b>Used in</b>
6841	3395145	230V	Europe/South America
6842	3395145	230V	England
6843	3395146	120V	USA/Taiwan/Canada
6844	3395147	100V	Japan
6845	3395148	240V	Australia
6846	3395145	220V	Korea

**SO WERDEN SERVICEARBEITEN AUSGEFÜHRT**

**Vor-Ort-Service**

Servicearbeiten an der BeoLab1, wie die Beseitigung elektrischer oder mechanischer Fehler, werden direkt vor Ort beim Kunden vorgenommen. Dazu zählt z.B. auch der Austausch von Front- und Lautsprecherabdeckungen, Gehäuse und Standfuß. Auf diese Weise entfällt der Transport dieses langen und schweren Lautsprechers (184 cm/36 kg) vom und zum Aufstellort beim Kunden.

Für diesen Vor-Ort-Service bieten wir einen eigenen Servicekoffer an (ähnlich wie beim BeoVision1), der alle notwendigen elektrischen Bauteile, bzw. Baugruppen enthält. Mechanische Teile (Front- und Lautsprecherabdeckung, Gehäuse, Standfuß) müssen separat bestellt werden (siehe Abb. 4-2).

**Service-Dokumentation**

Die Service-Dokumentation für den BeoLab 1 besteht aus einem „Handbuch für den Vor-Ort-Service“ und dieser „Reparaturanleitung für das Service-Center“ mit Bestellnummern für den Servicekoffer, mechanische Bauteile und Bedienungsanleitung.

**TYPENÜBERSICHT**

**Umstellen auf eine andere Betriebsspannung**

Falls ein Umstellen auf eine andere Betriebsspannung notwendig ist, z. B. beim Umzug in ein anderes Land, müssen zwei Service-Koffer für den im neuen Land angebotenen Typ bestellt werden (je Lautsprecher ein Koffer).

Beispiel: Bei einem Umzug aus der EU (Typ 6841) nach Japan (Typ 6844) bestellen Sie zwei Service-Koffer für den Typ 6844, Bestellnummer: 3395147.

<b>Typen Nr.</b>	<b>Bestell Nr.</b>	<b>Betriebsspannung</b>	<b>verwendet in</b>
6841	3395145	230V	Europe/South America
6842	3395145	230V	England
6843	3395146	120V	USA/Taiwan/Canada
6844	3395147	100V	Japan
6845	3395148	240V	Australia
6846	3395145	220V	Korea

**METHODE D'ENTRETIEN****Entretien sur site**

BeoLab 1 doit être entretenu sur le site des consommateurs en ce qui concerne les problèmes électriques ou l'échange de pièces mécaniques, telles que le cadre frontal, le capot avant, le coffret ou le pied. Vous évitez ainsi de transporter le haut-parleur, qui est long et lourd (184 cm/ 36 kg), hors de chez le consommateur.

Dans le cadre de l'entretien sur site, nous proposons une malette d'accompagnement (même principe que pour BeoVision). Cette malette contient tous les composants électriques nécessaires. Les pièces mécaniques (cadre frontal, capot avant, coffret ou pied) doivent être commandées séparément.

**Documentation d'entretien**

La Documentation d'entretien du BeoLab 1 se présente sous la forme d'un Guide d'entretien sur site et du présent "Guide de réparation en station technique" qui comporte les numéros de pièces pour la malette d'accompagnement, les pièces mécaniques et le Guide d'utilisation.

**EXAMEN TYPE****Conversion de la tension d'alimentation secteur**

S'il s'avère nécessaire de modifier la tension d'alimentation, à l'occasion d'un déménagement à l'étranger par exemple, il convient de commander deux malettes d'accompagnement pour le type vendu dans le pays concerné (une pour chaque haut-parleur).

Exemple : En cas de déménagement des Etats-Unis (type 6841) au Japon (type 6844), commander deux malettes d'accompagnement pour le type 6844, n° de commande : 3395147.

<b>N° de type</b>	<b>N° de commande.</b>	<b>Tension secteur</b>	<b>Pays</b>
6841	3395145	230V	Europe/South America
6842	3395145	230V	England
6843	3395146	120V	USA/Taiwan/Canada
6844	3395147	100V	Japan
6845	3395148	240V	Australia
6846	3395145	220V	Korea

**ASSISTENZA****Prima assistenza**

BeoLab 1 deve essere riparato al domicilio del consumatore relativamente a guasti elettrici o sostituzione di parti meccaniche, quali telaio anteriore, copertura anteriore, cabinet o sostegno. In tal modo si eviterà il trasporto delle lunghe e pesanti casse acustiche (184cm/36kg) dal domicilio del cliente.

Per la prima assistenza offriamo una valigetta di pezzi di ricambio (lo stesso principio di BeoVision), nella quale è possibile trovare tutte le parti elettriche necessarie. Le parti meccaniche (telaio anteriore, copertura anteriore, cabinet o sostegno) devono essere ordinate separatamente.

**Documentazione per l'assistenza**

La documentazione per l'assistenza di BeoLab 1 è costituita da una "guida per l'assistenza a domicilio" e questa "guida alla riparazione del Centro assistenza" con numeri di parte per la valigetta dei pezzi di ricambio, parti meccaniche e Guida dell'utente.

**INFORMAZIONI SUL TIPO****Trasformazione della tensione di alimentazione**

Se è necessario trasformare la tensione di alimentazione, ad esempio a causa del trasferimento in un altro paese, occorre ordinare due valigette di pezzi di ricambio per il tipo venduto nel nuovo paese (una per ciascuna cassa acustica).

Ad esempio: Trasferimento da un paese UE (tipo 6841) in Giappone (tipo 6844); ordinare due valigette di pezzi di ricambio per il tipo 6844, N° ordine: 3395147.

<b>N° di tipo</b>	<b>N° ordine</b>	<b>Tensione alimentaz.</b>	<b>Utilizzato in</b>
6841	3395145	230V	Europe/South America
6842	3395145	230V	England
6843	3395146	120V	USA/Taiwan/Canada
6844	3395147	100V	Japan
6845	3395148	240V	Australia
6846	3395145	220V	Korea

**CÓMO REALIZAR EL MANTENIMIENTO****Mantenimiento inmediato**

El mantenimiento del BeoLab 1 debe realizarse en el domicilio del consumidor, por lo que se refiere a temas eléctricos o sustitución de componentes mecánicos como la estructura frontal, la cubierta frontal, la cabina o el pie. Así se evita tener que transportar el gran y pesado altavoz (184 cm/ 36 kg) desde y hasta el domicilio del consumidor. Para el servicio directo ofrecemos un maletín auxiliar (el mismo principio que para el del BeoVision). Todos los componentes eléctricos se encuentran en este maletín. Los componentes mecánicos (estructura frontal, cubierta frontal, cabina o pie) deben solicitarse por separado.

**Documentación de mantenimiento**

La documentación de mantenimiento para el BeoLab 1 será una "Guía de mantenimiento «in situ»" y esta "Guía de Reparación en taller" con los números de referencia para el maletín auxiliar, los componentes mecánicos y la Guía del Usuario.

**TIPOS****Conversión del voltaje de la red eléctrica**

Si fuera necesario cambiar el voltaje, por ejemplo, al ir de un país a otro, sería necesario solicitar dos maletines auxiliares para el tipo que se venda en cada país concreto (uno para cada altavoz). Por ejemplo: Al viajar de la Unión Europea (tipo 6841) a Japón (tipo 6844), pida dos maletines para el tipo 6844, número de referencia: 3395147.

<b>Tipo</b>	<b>ref. maletin</b>	<b>Tensión de red</b>	<b>Utilizado en</b>
6841	3395145	230V	Europe/South America
6842	3395145	230V	England
6843	3395146	120V	USA/Taiwan/Canada
6844	3395147	100V	Japan
6845	3395148	240V	Australia
6846	3395145	220V	Korea

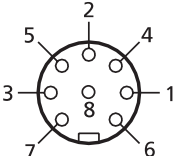
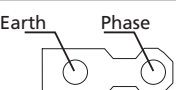
SPECIFICATION GUIDELINE FOR SERVICE USE	BEOLAB 1	
Type no.		
6841	EUROPE	230V
6842	ENGLAND	230 V
6843	USA, CANADA, TAIWAN	120 V
6844	JAPAN	100 V
6845	AUSTRALIA	240 V
6846	KOREA	220 V
<b>Dimensions</b>	Height 1840 mm	
	Foot ø 398 mm,	
	Weight 36 kg	
Box for 1 loudspeaker / cabinet	L 2000 x W 292 x H 262 mm	
Box for 1 foot:	L 500 x W 500 x H 200 mm	
<b>Cabinet finish</b>	Aluminium, black, green, red, blue (Avant colours)	
Power Consumption typical	15 watts or SPL = 70 dB	
	Standby: <0.5 watts	
Input impedance	47kΩ	
Maximum Sound Pressure Level	105 dB (stereo, pair)	
Power amplifiers	3	
Long-term maximum, output power, per amplifier	Bass: 300 watts	
	Midrange: 75 watts	
	Treble: 75 watts	
Effective Frequency range	39 - 20,000 Hz	According to IEC 268-5
Crossover frequency	800/4000 Hz	
Cabinet principle	Closed box	
Magnetically shielded	Yes	
Woofers	2 x 16.5 cm (6.5")	
Midrange	7.6 cm (3")	
Tweeter	2.5 cm (1")	
Net volume	16 litres	
Bass equalisation	ABL (Adaptive Bass Linearisation),	
	Switch for loudspeaker position: Free - Wall - Corner.	
Input sensitivity (line)	125 mV (91dB SPL per channel at 1m)	
Switch off time (line)	3 min.	
<b>Connections</b>	2 x Power Link	
	Phono (line)	
<b>POWER LINK plug for BeoLab 1</b>	<b>Power Link</b>	
Pin 1: Loop through, Power Link plugs		
Pin 2: Signal GND		
Pin 3: Audio Left 0V - 2V RMS		
Pin 4: Power Link speaker ON = > 0.5V, OFF = < 0.5V		
PIN 5: Audio Right 0V - 2V RMS		
Pin 6: Loop through, Power Link plugs		
Pin 7: Loop through, Power Link plugs		
Pin 8: Loop through, Power Link plugs		
		
	<b>Mains Plug</b>	
		
<b>Subject to change without notice</b>		



**BRIEF OPERATION GUIDE**

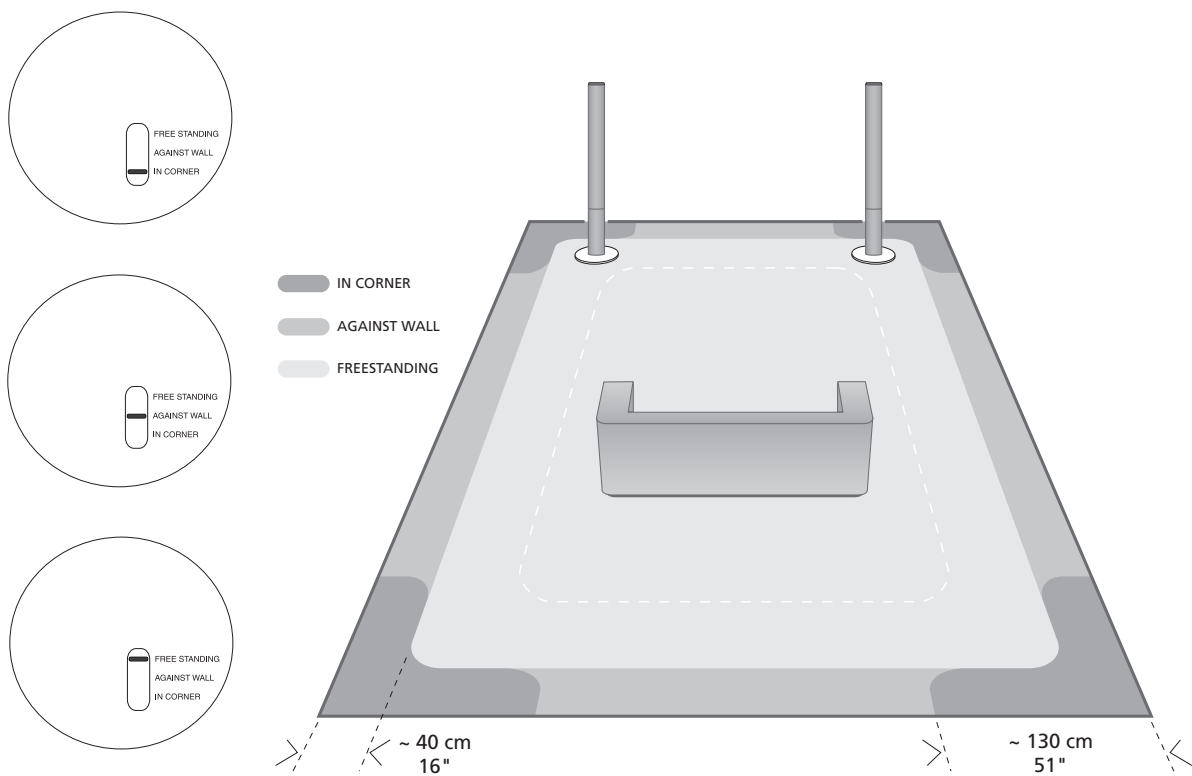
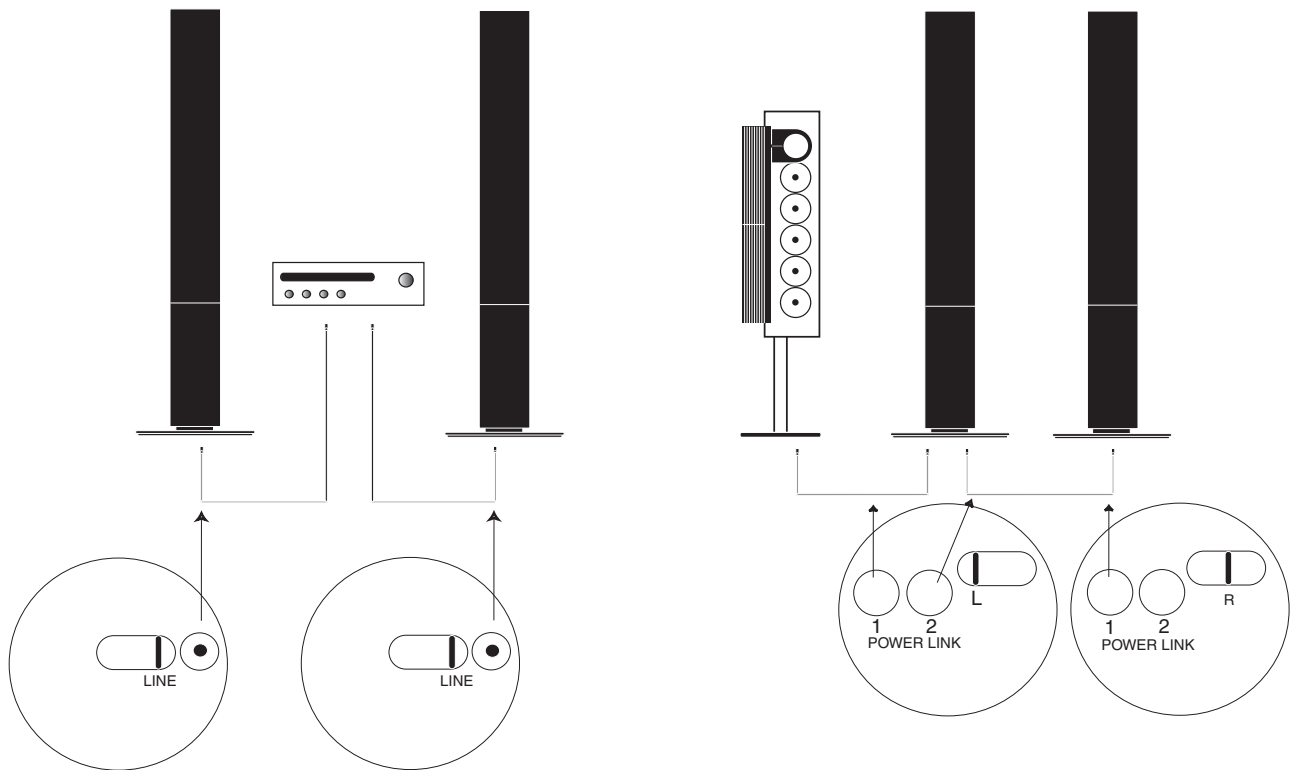

**PARTS LIST**

	3395145	Type 6841	Back-up suitcase, 230V AC
	-	- 6842	-
	-	- 6846	-
	3395146	- 6843	Back-up suitcase, 120V AC
	3395147	- 6844	Back-up suitcase, 100V AC
	3395148	- 6845	Back-up suitcase, 240V AC
9001	3431083	Green	Loudspeaker cabinet
	3431084	Blue	Loudspeaker cabinet
	3431085	Grey	Loudspeaker cabinet
	3431086	Red	Loudspeaker cabinet
	3431087	Black	Loudspeaker cabinet
9002	8006583	NTC-PCB	(included in back-up suitcase)
9003	3320482	Green	Front cloth
	3320483	Blue	Front cloth
	3320484	Grey	Front cloth
	3320485	Red	Front cloth
	3320486	Black	Front cloth
9004	2569663	Grey	Front cover
	2569664	Green	Front cover
	2569665	Blue	Front cover
	2569666	Red	Front cover
	2569667	Black	Front cover
9005	2752051	Complete foot	
9006	8480311	Woofers	(included in back-up suitcase)
9007	8480312	Midrange	(included in back-up suitcase)
9008	8480313	Tweeter	(included in back-up suitcase)
999	8006578	Amplifier EU 230V	(included in back-up suitcase 3395145)
	8006579	Amplifier US 120V	(included in back-up suitcase 3395146)
	8006580	Amplifier JPN 100V	(included in back-up suitcase 3395147)
	8006581	Amplifier AUS 240V	(included in back-up suitcase 3395148)

**Survey of screws etc.**

1	2015139	Screw, 3.5 x 16 mm
2	2054016	Screw, 40 x 18 mm
3	2054018	Screw, 50 x 25 mm
4	3390563	Bag with six screws and Allen key
5	3151551	Holder front profile, upper left
6	3151574	Holder front profile, upper right
7	3151439	Holder front profile, lower
8	3103392	Foot, "soft"

**Mains cable**

9010	6100273	Europe/Korea, type 6841, 6846
9011	6100329	Great Britain, type 6842
9012	6100307	United States/Canada/Taiwan, type 6843
9013	6100331	Japan, type 6844
9014	6100332	Australia, type 6845

**Parts not shown**

3390586	Cable hide set
3392588	Carton box for Iron foot
3396040	Foam pack for Iron foot
3392587	Carton box for loudspeaker
3396027	Foam pack for loudspeaker
3917105	Super foam 1mm+0.015mm (2 pce)
2777037	Handle type 80 (holder sheet)
2777038	Handle type 80 (strap)
3187200	Insert for plugs
6270644	Power Link Cable black, 2.5 m
6270645	Power Link Cable black, 5 m
6270646	Power Link Cable black, 10 m
6270647	Power Link Cable black, 20 m
3658269	Product cover (for transportation)



**AVAILABLE DOCUMENTATION**

**On-site service guide**

3546039 Multi language

---

**User's guide**

3506251 Denmark  
3506252 Sweden  
3506253 Finland  
3506254 England  
3506255 Germany  
3506256 Netherlands  
3506257 Franc  
3506258 Italy  
3506259 Spain  
3506260 Japan  
3506261 Korea  
3506262 Taiwan  
3506263 Hebrew  
3506264 Poland  
3506265 Portugal  
3506266 Saudi Arabia  
3506267 Greece

---

**ADJUSTMENTS AND REPAIR TIPS**

**TIPS FÜR EINSTELLUNGEN UND REPARATUR**

**CONSEILS DE REGLAGE ET DE REPARATION**

For instance, if the value on the tweeter unit is "-1.5 dB", the position of the switch has to be 7.

Wenn der auf der Hochtönergruppe angegebene Wert z. B. "-1.5 dB" beträgt, muß der Schalter in die Position 7 gebracht werden.

Par exemple, si la valeur figurant sur le haut-parleur d'aigus indique "-1,5 dB", la position de l'interrupteur doit être 7.

Value on the back of the loudspeaker unit	Switch position
1.8 – 2.3	0
1.3 – 1.7	1
0.8 – 1.2	2
0.3 – 0.7	3
- 0.2 – 0.2	4
- 0.3 – -0.7	5
- 0.8 – -1.2	6
- 1.3 – -1.7	7
- 1.8 – -2.2	8
- 2.3 – -2.5	9

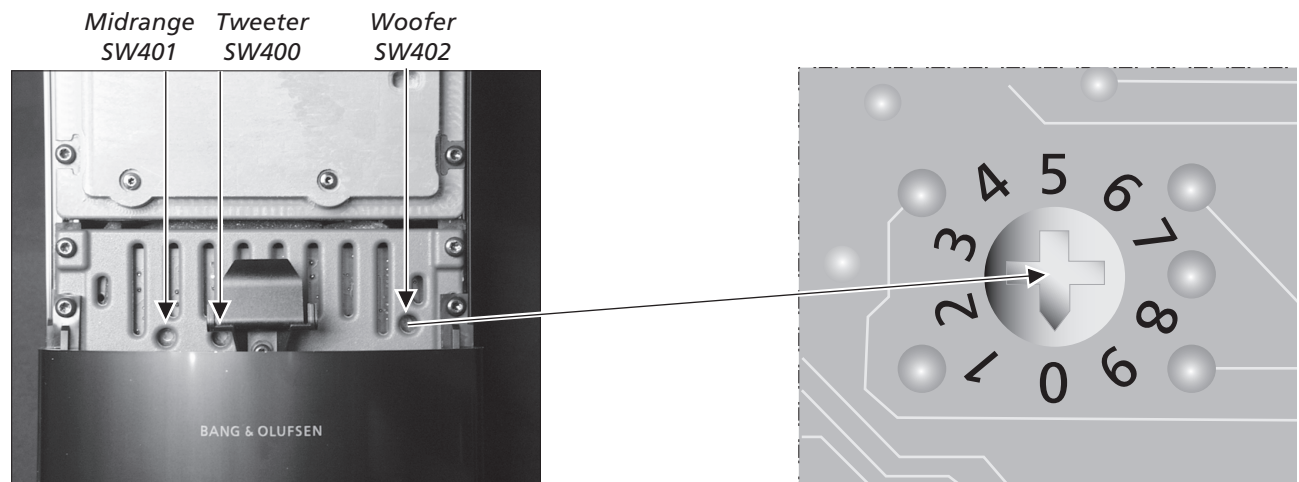

**Check switch**

Make sure that the switch on PCB1 is placed in the position to the right.

**Prüfen der Schalterstellung**

Überprüfen Sie, ob daß der Schalter am PCB1 in der rechten Position steht.

**Vérifier l'interrupteur**

Vérifier que l'interrupteur situé sur la carte PCB1 soit enclenché à droite.

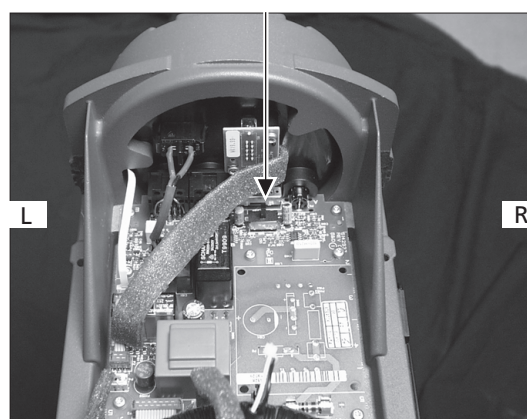

**CONSIGLI PER LA REGOLAZIONE E LA RIPARAZIONE**

Ad esempio, se il valore indicato per l'unità altoparlante è di "1,5 dB", la posizione dell'interruttore sarà 7.

**SUGERENCIAS PARA REPARACIÓN Y AJUSTES**

Por ejemplo, si el valor en el tweeter es "-1,5 dB", la posición del conmutador debe ser 7.

Value on the back of the loudspeaker unit	Switch position
1.8 – 2.3	0
1.3 – 1.7	1
0.8 – 1.2	2
0.3 – 0.7	3
-0.2 – 0.2	4
-0.3 – -0.7	5
-0.8 – -1.2	6
-1.3 – -1.7	7
-1.8 – -2.2	8
-2.3 – -2.5	9

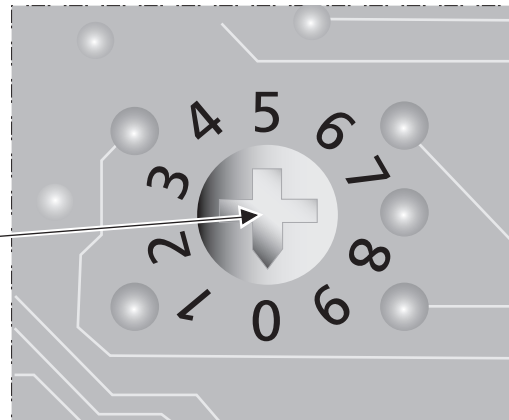
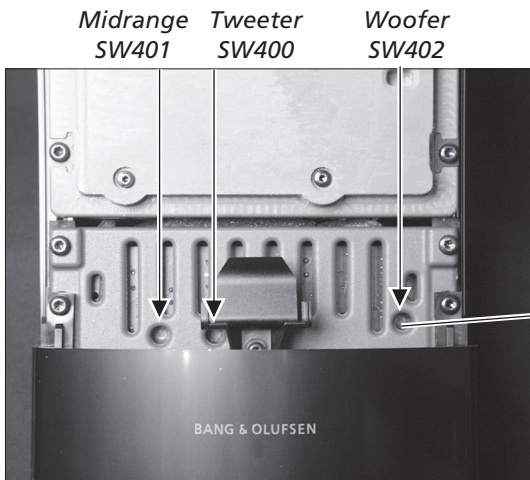

**Controllare gli interruttori**

Verificare che l'interruttore della scheda PCB1 sia posizionato verso destra.

**Comprobación del conmutador**

Asegúrese de que el conmutador de la PCB1 está colocado a la derecha.

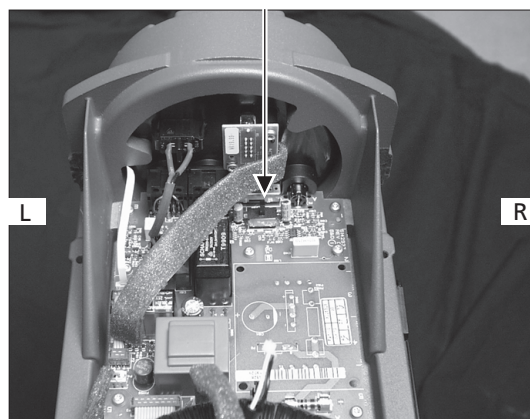

**DISASSEMBLY**

**DEMONTAGE**

**DEMONTAGE**

The loudspeaker in service position.

Für Reparaturarbeiten bringen Sie bitte den Lautsprecher in die abgebildete Position.

Enceinte en position d'entretien.

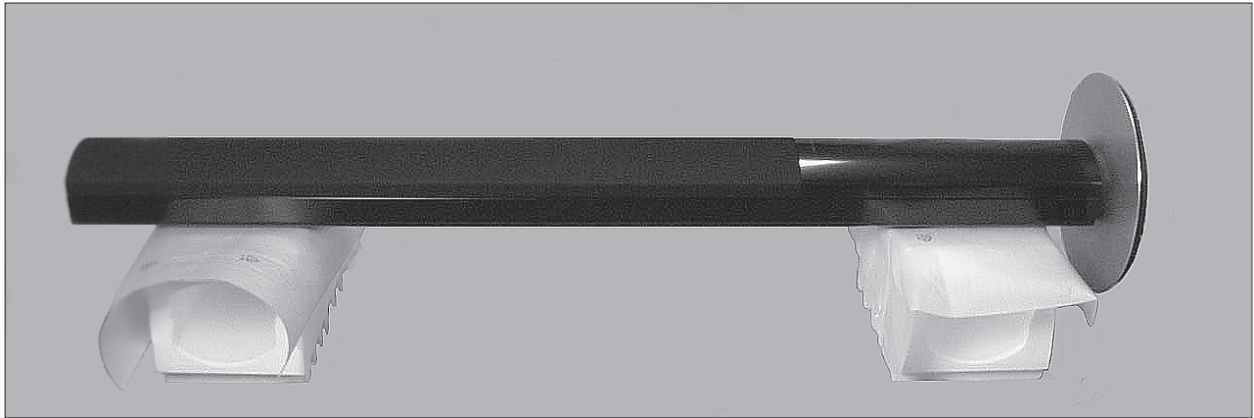

1. Push the release-mechanism.
2. Slide the front frame appr. 10 cm.
3. Lift the front frame up and away.

1. Betätigen Sie den Entriegelungsmechanismus.
2. Schieben Sie die Lautsprecherabdeckung um ca. 10 cm nach oben.
3. Nehmen Sie die Abdeckung vom Gehäuse.

1. Pousser le mécanisme de désemboîtement.
2. Faire coulisser le cadre frontal sur environ 10 cm.
3. Soulever et retirer le cadre frontal.

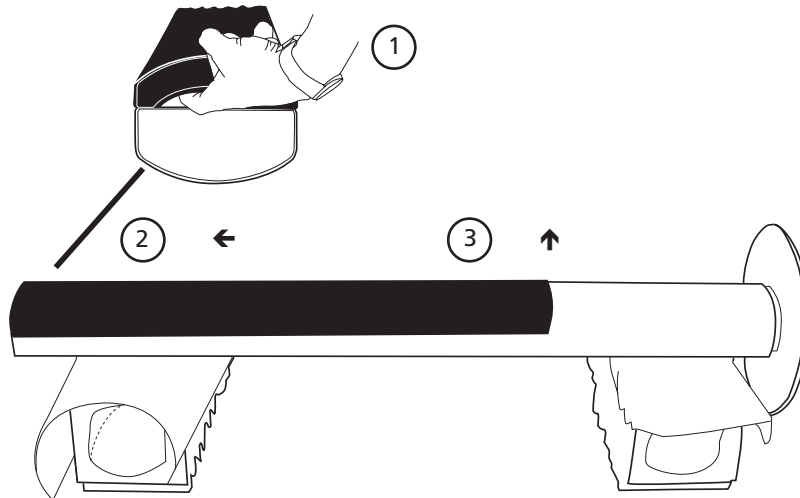

Remove the two screws and slide-off the front cover.

Entfernen Sie die beiden Schrauben , und ziehen Sie die vordere Abdeckung heraus.

Retirer les deux vis et faire coulisser le capot avant pour le déposer.

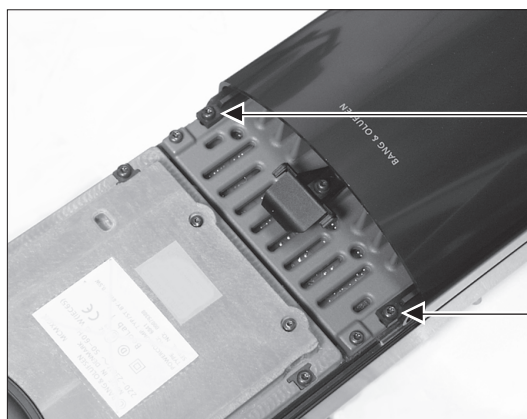



Remove the six screws and pull off the foot.

Entfernen Sie die sechs Schrauben, und ziehen Sie den Fuß ab.

Retirer les six vis et désemboîter le pied.

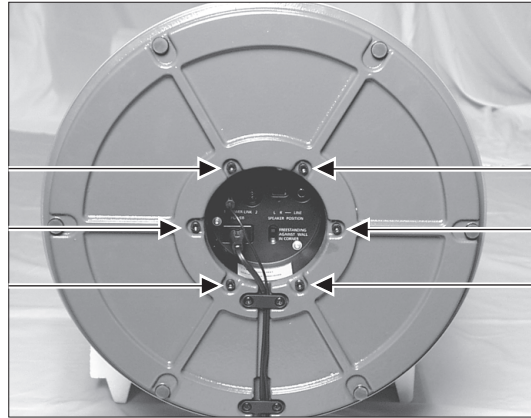

Remove the two screws with the special key.

Entfernen Sie mit Hilfe des Spezialschlüssels die beiden Schrauben.

Retirer les deux vis à l'aide de la clé spéciale.

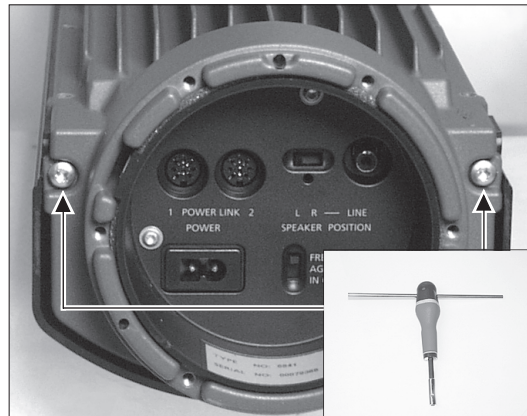

Remove the ten screws, lift and flip the cooling-profile.

Entfernen Sie die zehn Schrauben, heben Sie dann den Kühlkörper an und drehen Sie diesen auf die Rückseite.

Retirer les dix vis, soulever et, d'un petit coup sec, déposer le boîtier muni de fentes d'aération.

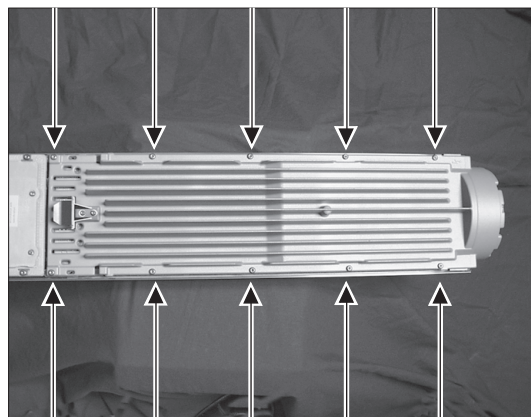



Lay down the cooling-profile in service position.

Legen Sie den Kühlkörper in der Position für Reparaturarbeiten ab.

Placer le boîtier muni de fentes d'aération en position d'entretien.

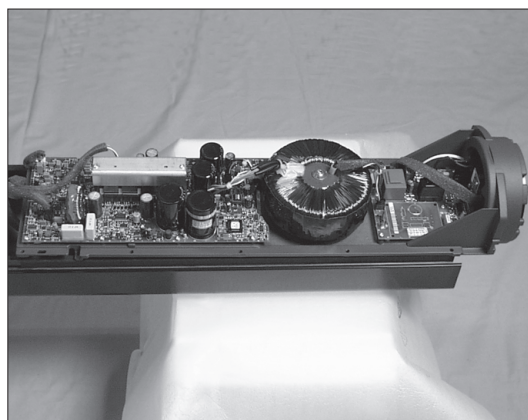

Pull off the two plugs.

Ziehen Sie die beiden Stecker ab.

Déconnecter les deux prises.

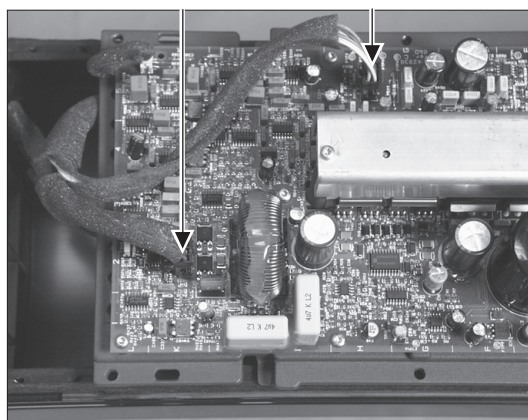

Remove the four screws and lift the bass unit and disconnect the two plugs.

"Lock" 

Entfernen Sie die 4 Schrauben, heben Sie den Baßlautsprecher an und ziehen Sie die beiden Stecker ab.

"Verriegelung" 

Retirer les quatre vis et soulever le haut-parleur de graves, puis débrancher les deux prises.

"Clavette" 

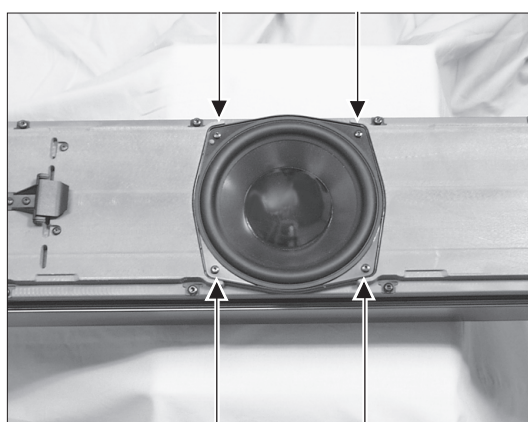

Remove the four screws and lift the bass unit and disconnect the two plugs. "Lock"



Entfernen Sie die 4 Schrauben, heben Sie den Baßlautsprecher an und ziehen Sie die beiden Stecker ab. "Verriegelung"



Retirer les quatre vis et soulever le haut-parleur de graves, puis débrancher les deux prises. "Clavette"

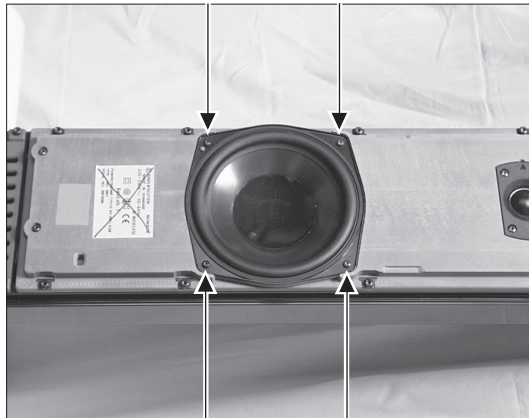
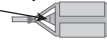

Disconnect the plug to the NTC-PCB.

Ziehen Sie den Stecker zum NTC-PCB ab.

Débrancher la prise reliée à la carte NTC-PCB.

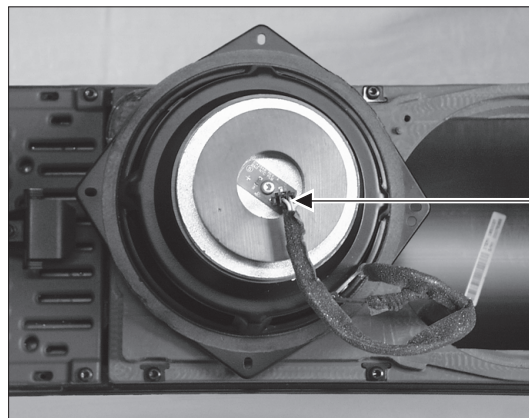

Remove the screws and disconnect the plugs. "Lock"



Entfernen Sie die Schrauben, und ziehen Sie die Stecker ab. "Verriegelung"

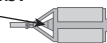

Retirer les vis et débrancher les prises. "Clavette"

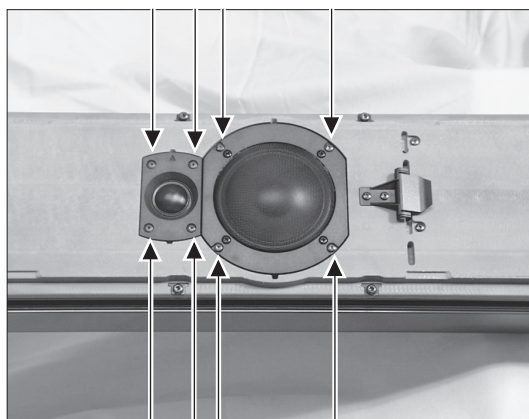
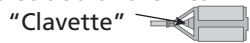

**SMONTAGGIO**

Posizionamento della cassa acustica per la manutenzione.

**DESMONTAJE**

Altavoz en posición de reparación y mantenimiento.



1. Premere il meccanismo di rilascio.
2. Fare scorrere il telaio anteriore di circa 10 cm.
3. Sollevare e togliere il telaio anteriore.

1. Pulse el mecanismo de liberación.
2. Deslice el bastidor frontal aproximadamente 10 cm.
3. Levante y retire la estructura frontal.

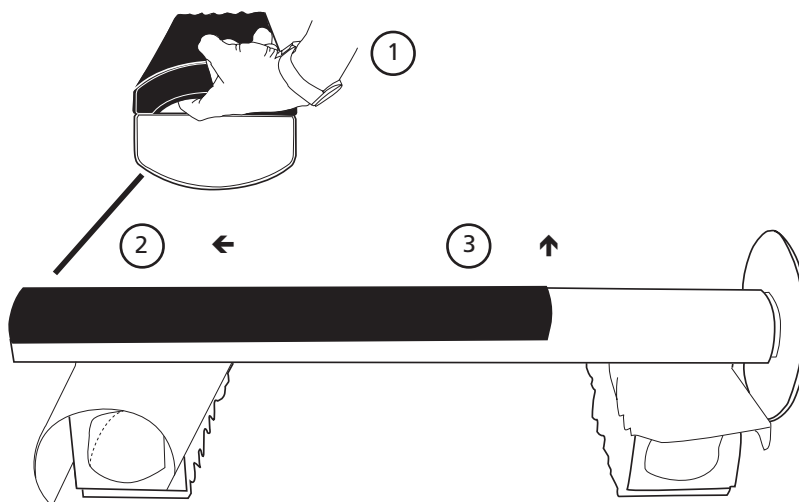

Rimuovere le due viti e far scorrere la copertura anteriore.

Retire los dos tornillos y deslice hacia afuera la cubierta frontal.

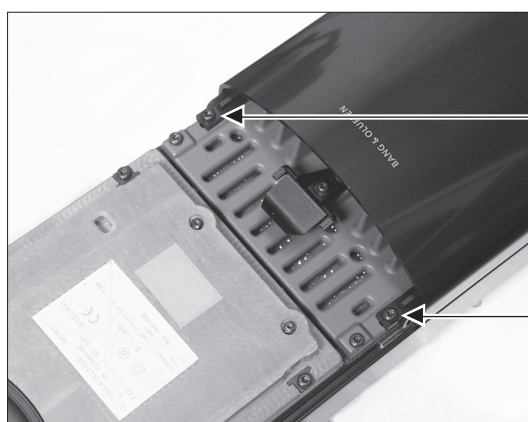

Rimuovere le sei viti ed estrarre il sostegno.

Retire los seis tornillos y saque el pie.

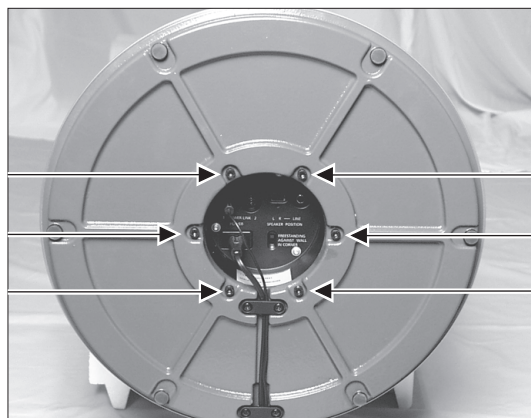

Rimuovere le due viti con l'apposita chiave.

Retire los dos tornillos con la llave especial.

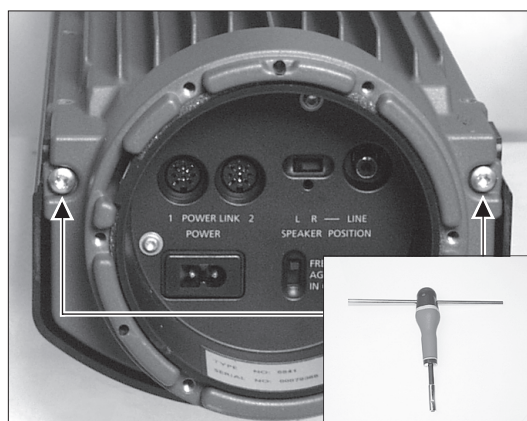

Rimuovere le dieci viti, sollevare e rimuovere l'unità di raffreddamento.

Retire los diez tornillos, levante y dé la vuelta a la placa de refrigeración.

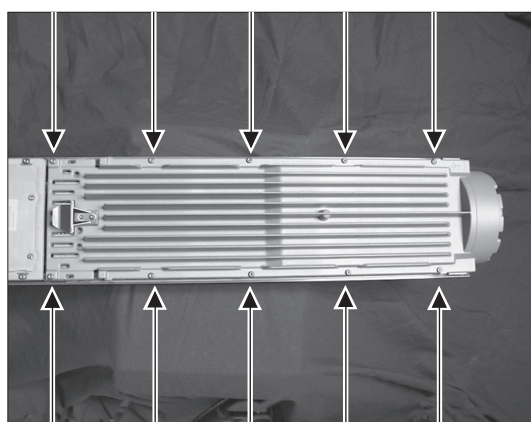



Poggiare l'unità di raffreddamento in posizione di riparazione.

Ponga el perfil de refrigeración en posición de reparación y mantenimiento.

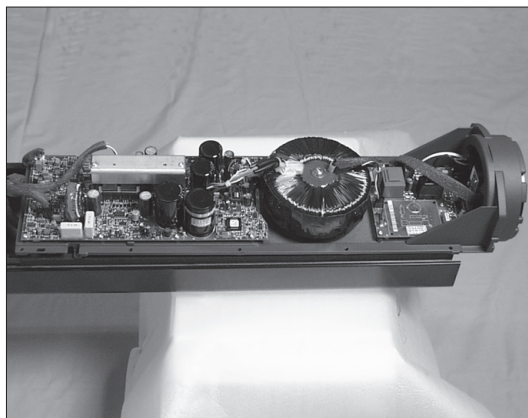

Togliere le due spine.

Saque los dos enchufes.

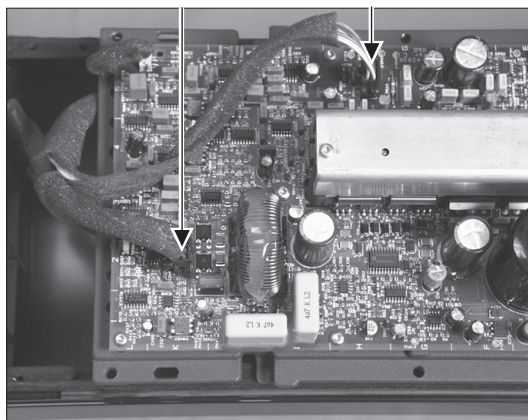

Rimuovere le quattro viti, sollevare l'unità basso e scollegare le due spine. "Blocco"

Retire los cuatro tornillos, levante la unidad de graves y desconecte los dos enchufes. "Bloqueo"

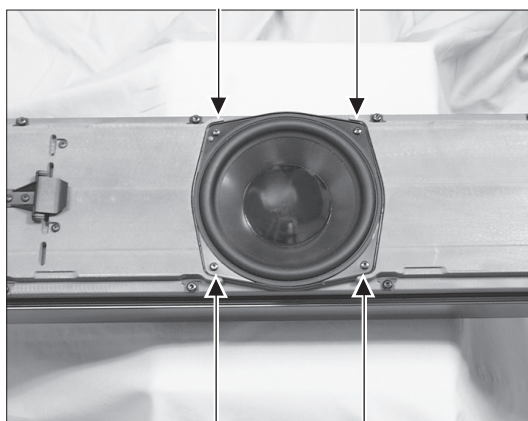
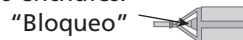
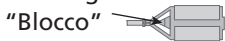

Rimuovere le quattro viti, sollevare l'unità basso e scollegare le due prese. "Blocco"

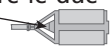

Retire los cuatro tornillos, levante la unidad de graves y desconecte los dos enchufes. "Bloqueo"

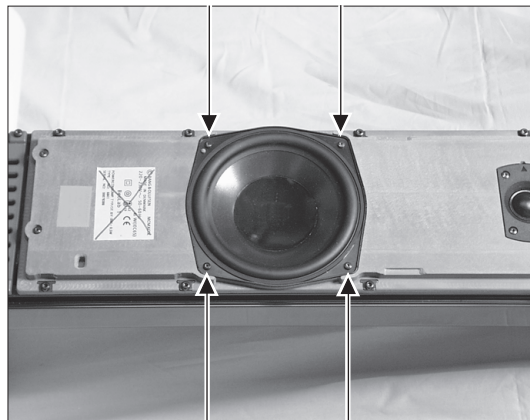
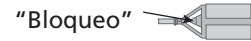

Scollegare la spina dell'NTC-PCB.

Deconecte el enchufe de la NTC-PCB.

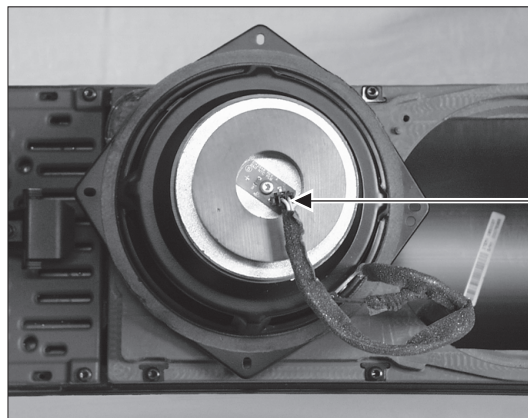

Rimuovere le viti e scollegare le spine. "Blocco"



Retire los tornillos y desconecte los enchufes. "Bloqueo"

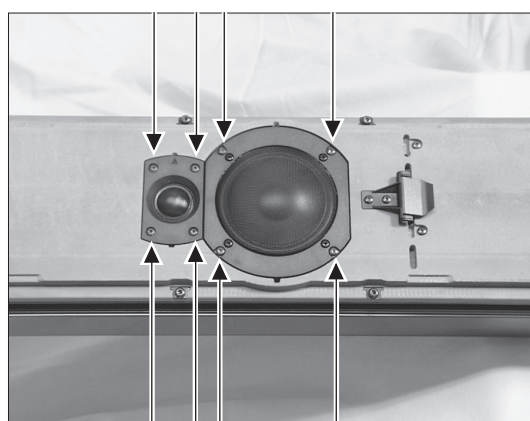

**AFTER REPAIR TIP****Cleaning the product**

Clean the BeoLab 1 using a soft, firmly wrung lint-free cloth which you have dipped in a solution of lukewarm water containing a few drops of mild detergent, e.g. a dish washing liquid.

Use a soft brush to remove any dust on the base, before cleaning it with a soft cloth.

**Do not use alcohol or other solvents to clean BeoLab 1.**

**TIPS NACH DER REPARATUR****Reinigen des Geräts**

Verwenden Sie zur Reinigung der BeoLab1 ein fusselfreies und weiches Tuch. Tauchen Sie dieses in lauwarmes Wasser, in das Sie ein paar Tropfen mildes Reinigungsmittel, z.B. Geschirrspülmittel gegeben haben.

Entfernen Sie mit Hilfe einer weichen Bürste erst den Staub vom Gehäuse, bevor Sie den Lautsprecher mit einem weichen Tuch abwischen.

**Verwenden Sie zum Reinigen des BeoLab1 keinen Alkohol oder andere Lösungsmittel.**

**CONSEIL APRES REPARATION****Nettoyer le produit**

Nettoyer BeoLab 1 à l'aide d'un chiffon doux non pelucheux, préalablement trempé dans une solution d'eau tiède contenant quelques gouttes d'un détergeant léger (liquide vaisselle par exemple), puis essoré.

Utiliser une brosse à poils doux pour éliminer la poussière du coffret, avant de le nettoyer à l'aide d'un chiffon doux.

**Ne pas utiliser d'alcool ou de solvant pour nettoyer BeoLab 1.**

**CONSIGLI SUCCESSIVI ALLA  
RIPARAZIONE**

**Pulitura del prodotto**

Per la pulizia di BeoLab 1 utilizzare un panno morbido, ben strizzato e privo di peli, precedentemente inumidito in una soluzione tiepida di acqua e poche gocce di detersivo non troppo forte, quale ad esempio un detersivo liquido per piatti. Utilizzare una spazzola morbida per rimuovere la polvere eventualmente presente sulla base prima di pulirla con un panno leggero.

**Non utilizzare alcol o altri solventi per la pulizia di BeoLab 1.**

**SUGERENCIA TRAS LA  
REPARACIÓN**

**Limpieza del producto**

Limpie el BeoLab 1 utilizando un paño suave, sin hilos y bien escurrido después de haberlo sumergido en una solución de agua templada con unas cuantas gotas de detergente suave, por ejemplo, un líquido lavavajillas. Utilice un cepillo suave para eliminar el polvo que pueda haber en la base antes de limpiarla con un paño suave.

**No use alcohol ni disolvente de ninguna clase para limpiar el BeoLab 1.**





**BANG & OLUFSEN  
DK - 7600 STRUER  
DENMARK**

**TELEPHONE (+45) 96 84 11 22\*  
TELEFAX (+45) 97 85 39 11**

**3538911 11-99**