

BeoLab 3500 MKII

Type 1601, 1602, 1603, 1604, 1605, 1607, 1608
from serial no. 19343452

Service Manual
English

German and French, versions are available in the Retail System

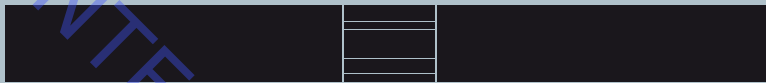

ABO-CENTER V/HENRIKSENS ELEKTRONIK

CONTENTS

Survey of modules	1.1
Adjustments	2.1
Repair tips	3.1
Disassembly	4.1
Insulation test	5.1
Specification guidelines for service use	6.1
Wiring diagram	7.1
Block diagrams	7.3 – 7.5
Available parts	8.1

ABC-CENTER V/HENRIKSENS ELEKTRONIK

Seen from the front

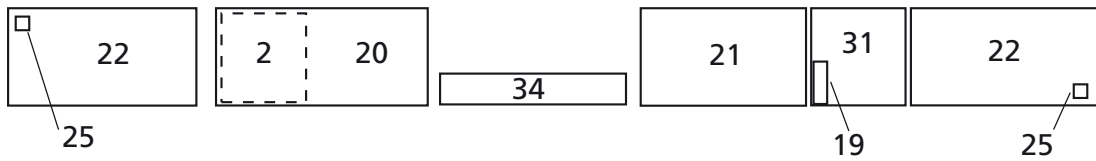

Seen from the back

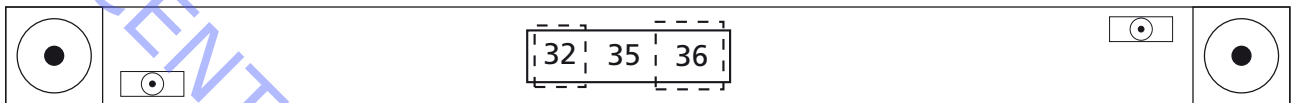

- 2 Switch Mode Power Supply
- 19 DC/DC Converter
- 20 Transformer left
- 21 Transformer right
- 22 Power Amplifier left
- 22 Power Amplifier right
- 25 NTC
- 31 LF Supply and Control
- 32 Cross Field
- 34 Plug PCB
- 35 Display, Keyboard and IR Receiver
- 36 Microcomputer

ABO-CENTER V/HENRIKSENS ELEKTRONIK

ADJUSTMENTS

5V

When replacing IC1, LM3578, on PCB2, Switch-Mode Power Supply, the supply voltage may have to be adjusted to $5V \pm 0.25V$ by means of R2 and R10:

- If 5V is above level, install R2 (R1//R2).
- If 5V is below level, install R10 (R3//R10).

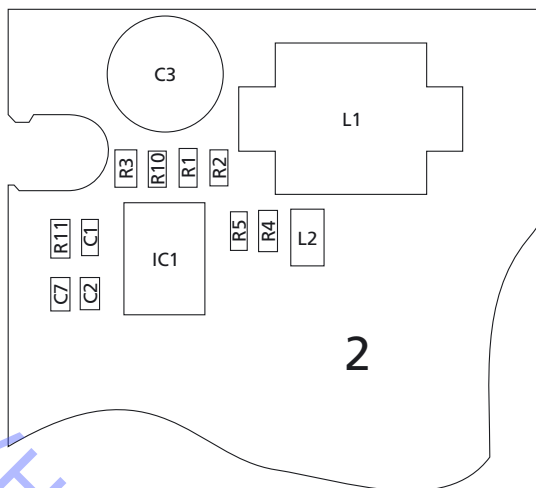

SPEAKER

Adjustment of bass/treble sound level.

To be carried out only when replacing a speaker unit or PCB36, Microcomputer.

TEST MODE 01

This test mode permits manual adjustment of speaker bass and treble levels and can only be executed from stand-by with a Beo4.

- Press **MENU 0 1 GO**.
The display reads SPK.CAL. to indicate that the product is ready for speaker calibration.
- Press **GO**.
The display shows the present adjustment:
'X X X X' = left bass (LB).
'X X X X' = left treble (LT).
'X X X X' = right treble (RT).
'X X X X' = right bass (RB).

The value that can be changed is flashing. Press >> or << to change unit of adjustment, and change the value by pressing the digit keys. When all four speakers have the desired encoding, press **STORE**, and abandon test mode by pressing **STOP**.

Replacement of PCB36, Microcomputer

The bass and treble levels of the speakers are stored electronically in the Microcomputer (PCB36). When replacing PCB36, the original bass and treble level values must be restored:

- Install the new Microcomputer (see section 4, Disassembly, if necessary).
- In TEST MODE 01, enter the values printed on the label in the socket well:
LT (left treble) : X LB (left bass) : X
RT (right treble) : X RB (right bass) : X
- Press **STORE STORE** when all four speakers have been encoded as desired.

Replacement of a speaker unit

A rated value in dB is printed on the back of the new speaker unit. This value is used for adjusting the sound level, which is done in TEST MODE 01:

- Note the value on the back of the new speaker unit
- Replace the old speaker unit.
- Execute the point TEST MODE 01.
- The rated value printed on the back of the speaker may be either positive or negative:

Positive:

If the rated value printed on the back of the speaker is positive, the unit in question must be damped by X number of steps. Press >> to select speaker, if necessary (the active speaker is flashing), and enter a new digit (see table).

Negative:

If the rated value printed on the back of the speaker is negative, the other three units must be damped by X number of steps. Press >> to select the three speakers in question, and enter new digits (see table).

Rated value in dB	X steps down
0.00 +/-0.25 +/-0.50	0 steps down
+/-0.75 +/-1.00 +/-1.25 +/-1.50 +/-1.75	1 step down
+/-2.00	2 steps down

- Press **STORE** when all four speakers have the desired encoding.
- Abandon test mode by pressing **STOP**.

REPAIR TIPS

BeoLab 3500 can be brought into TEST MODE from stand-by with a Beo4, giving access to the following functions:

TEST MODE 00

Display of: Software version number and time of operation in Audio mode, Video mode and stand-by.

- Press **MENU 0 0 GO**.
The display reads: **SW X.Y**, which is the software version number.
- Press **▲**
The display reads: **A: XXXXX**, which is the Audio mode operating time in hours x 10.
- Press **▲**
The display reads: **B: XXXXX**, which is the Video mode operating time in hours x 10.
- Press **▲**
The display reads: **C: XXXXX**, which is the stand-by operating time in hours x 10.
Press **▲** or **▼** to scroll in the scroll menu, and abandon test mode by pressing **STOP**.

TEST MODE 01

Electronic adjustment of the bass and treble levels of the speakers. See section 2, Adjustments.

SERVICE SET-UP

BeoLab 3500 is connected to a Beomaster as an ordinary Master link installation. As regards option programming, see User's Guide.

TEST MODE 02

Display of Master Link error types. Gives an identification of the error types that may occur in the Beolink installation.

- Press **MENU 0 2 GO**
The display reads:
ML OK = The Master Link connection is OK.
Or
NO ML = Master Link is not connected.
Or
ERROR 1 = Address configuration impossible.
Or
ERROR 2 = Master Link data pulled low.
Or
ERROR 3 = Master Link data pulled high.
Or
ERROR 4 = Data collision on Master Link.
- Press **STOP** to abandon display of Master Link error types and to delete registered errors.

The Master Link error system is a part of the software in the product. It registers communication errors between the microcomputer, the data transceiver circuits (PCB35) and the products connected to BeoLink. The error types will be described below, and tips will be given regarding how the cause of the error can be found:

ERROR 1:

Error during address configuration. No address has been allocated because too many units are connected to the BeoLink.

- Remove all products from BeoLink, and connect them again one at a time until the error code occurs. Disconnect that product from BeoLink.

ERROR 2:

It is not possible to transmit on BeoLink, because it has been pulled low. The error may occur if there is no Master Link driver circuit, or as a result of a physical short-circuit on BeoLink or in the data transceiver circuits.

- Disconnect one product from BeoLink at a time, and see if it starts up.
- Reset the faulty product, and check the connection (cable/plug) and signal path (the data transceiver circuits).

ERROR 3:

It is not possible to transmit on BeoLink, because it has been pulled high. This error is caused either by the pull-up resistance in the system having become too small or by an error in the data transceiver circuit.

- Disconnect one product from BeoLink at a time, and see if it starts up.
- Reset the faulty product, check whether the Master Link cable is too long, and check the signal path (the data transceiver circuit).

ERROR 4:

The data traffic on BeoLink has been excessive, or a product has jammed and will not receive telegrams.

- Press the operating sequence again.
- Disconnect one product from BeoLink at a time to determine which product has jammed. Reset the faulty product, and check the Master Link connection (cable/plug) and signal path (amplifiers in the data transceiver circuit).

TEST MODE 0 3

Direct selection of Master Link input. Permits the Master Link signal path to be tested without having a BeoLink master connected.

- Press **MENU 0 3 GO**
The display reads:
ML SEL. = Opens the Master Link signal path.
- Press **STOP** to close the Master Link signal path.

DISASSEMBLY

Front fabric frame

- Push the front fabric frame to the side and lift it off.

When both front fabric frames have been removed, PCB35, Display, Keyboard & IR receiver, PCB36, Microcomputer, and PCB32, Cross field, are accessible:

- Remove the display glass (two screws) and the two plastic covers (four screws). PCB35 can now be tilted out into service position, thereby also providing access to PCB36 and PCB32.

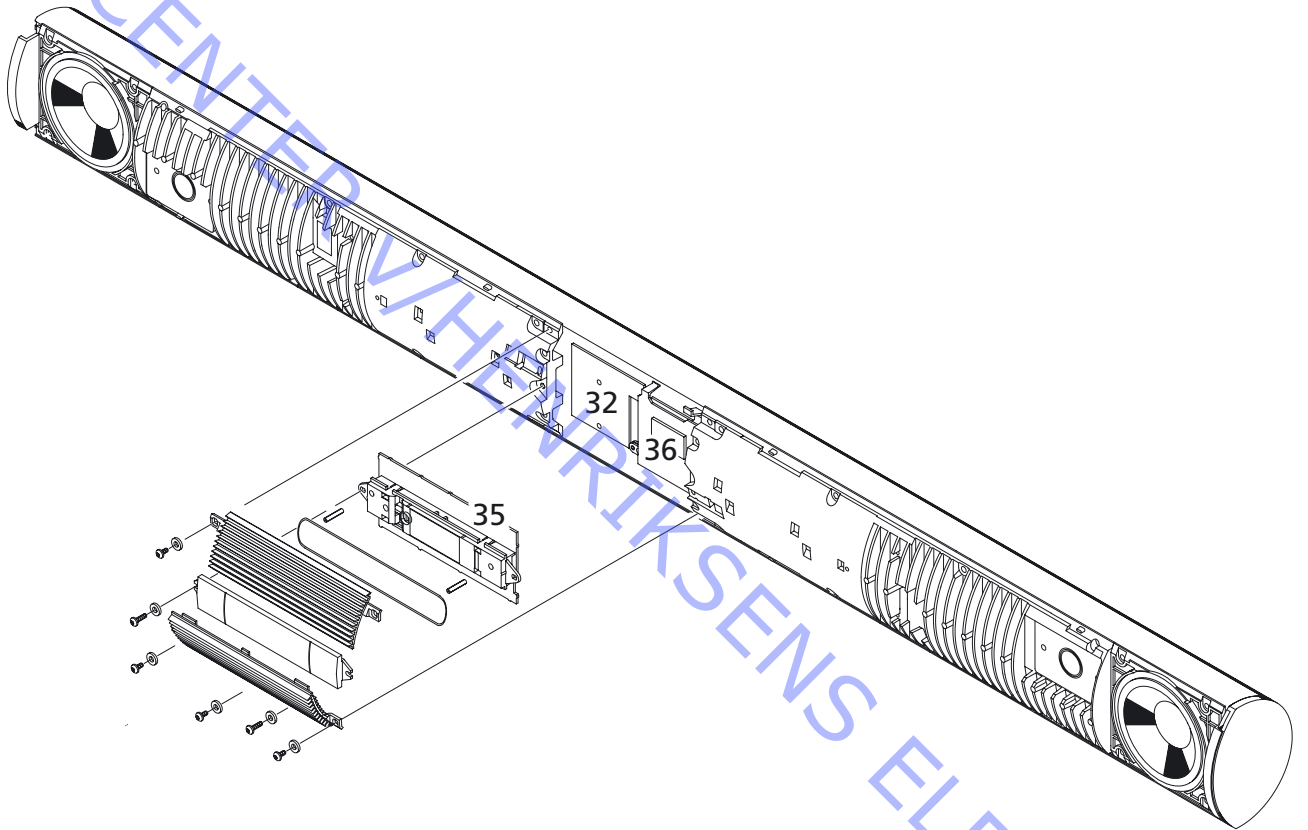

Service position**Important!**

The display glass and cabinet must be protected against scratches by placing them on a soft base.

- Remove the sixteen screws, A, behind the front fabric frames.
- Place the front face down.

- Remove the socket well by first removing the two Allen screws.

- Lift the cabinet up and off carefully. Place the cabinet parallel to the electronics block, and remove the two woofer plugs (22P4) if necessary.

- When assembling the product, lower the electronics block carefully down into the cabinet. Place the woofer leads at the centre of the cabinet so that they will not rattle against the cabinet sides.

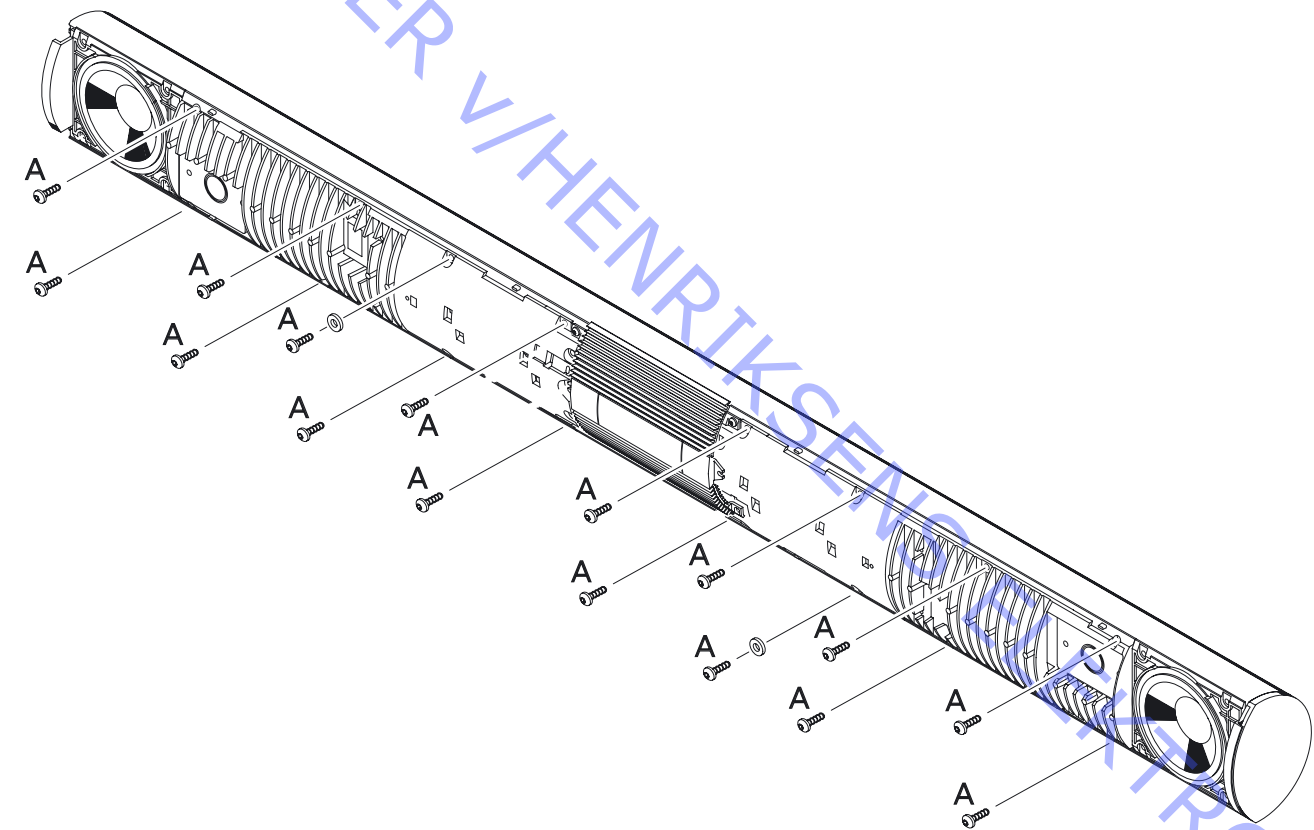

INSULATION TEST

Each set **must** be insulation tested after dismantling. The test is to be performed when the set has been re-assembled and is ready for delivery to the customer.

Make the insulation test as follows: Short-circuit the two plug pins of the mains plug and connect one of the terminals of the insulation tester. Connect the other terminal of the insulation tester to the chassis of the 8-pin DIN socket.

N.B.!

To avoid ruining the set, it is essential that both insulator test terminals are in really good mechanical contact.

Now turn slowly the voltage control of the insulation tester until a voltage of 1.3kV is obtained. Hold it there for 1 second, then turn slowly the voltage down again.

At no point during the testing procedure any flash-overs are permissible.

ABO-CENTER V/HENRIKSENS ELEKTRONIK

ABO-CENTER V/HENRIKSENS ELEKTRONIK

SPECIFICATION GUIDELINES FOR SERVICE USE

BeoLab 3500 MKII	Type 1601 (EU), 1602 (GB), 1603 (USA-CDN), 1604 (JAP), 1605 (AUS) 1607 (KOR), 1608 (CHK)
Concept	
X-tra room product	Active stereo loudspeaker with control circuitry, stand-by relay and IR receiver
Operation	
Local operation	Two sensi-touch fields with restricted operation (Mute/on/off/listen-in, timer on/off)
Remote operation	Beolink 1000 or Beo4, one-way (optional extra)
Status feedback	Red 8 char. LED dot matrix display, (program source, program or track number, record, clock)
Independent sound control	Red LED 1.8mm (Timer indication)
Compatibility	Volume, balance, bass, treble, loudness Master Link Wireless 1 via 8-pin DIN plug
Cabinet	
Rear finish	Polished aluminium, high gloss
Front cloth	Black
Center front	Black aluminium/plastic
Wall bracket	Grey plastic
Placement	
Wall	Wall bracket included
Stand	Polished aluminium (optional extra)
Acoustics	
Cabinet net volume per channel	0.8 litres
Woofers in each channel	9 cm - 3½"
Tweeters in each channel	1.8 cm - ¾"
Crossover frequency	3000 Hz
Bass reflex principle	Port
Electronics	
Overload protection	Yes
Volumecontrol	+12 dB in relation to central room
Bass/treble equalization	±12 dB, 100Hz/20kHz
System data	
Principle	Active, Bass reflex, 2-way, bi-amp, stereo
Frequency response	70 - 22.000 Hz +4 -8 dB, half field
Sound Pressure Level	95 dB weighted noise (IEC 268-5), stereo, half room, 3m
Harmonic distortion 250 - 1,000Hz	<10% 94 dB SPL, 1m
Harmonic distortion 1,000 - 5,000Hz	<3% 94 dB SPL, 1m
Minimum distance to TV	25cm

Power amplifiers

Rated power woofer	35W, 8Ω
Rated power tweeter	35W, 8Ω
Amplifier signal-to-noise ratio	> 80 dBA, 1W/8Ω
Signal-to-noise ratio	> 74 dBA, full volume
Frequency range	20 - 20,000 Hz +0 -1 dB
Harmonic distortion	< 0.1%
Total harmonic distortion	< 0.3% IHF
Cross talk	50 dB
Active crossover network	24 dB/octave Linkwitz/Riley
Low frequency equalization	+12 dB/60 - 250 Hz, ABL
High pass filter	30 dB/octave, 60 Hz

Connections

Mains	Cable included, 3 meters
	230V AC, 1601 EU, 1607 KOR, 1608 CHK
	240V AC, 1602 GB and 1605 AUS
	120V AC, 1603 USA - CDN
	100V AC, 1604 JAP
BeoLink Wireless 1 (W1)	8-pin DIN 45326 socket

Dimensions

Total dimensions W x H x D (on wall)	111 x 9.5 x 11 cm
Power consumption, operation	95 watts (230V)
Power consumption, stand-by	1.1 watt, 'Dot' in display
	3 watt, 'Watch' in display
Weight	10 kg, without stand

Optional accessories

Beo4	Type 1627
Wall bracket	Type 1607 - 3031302
Wall bracket	3031235
Wall plate	3031333
Table stand	Type 1606 - 1160611
Cable cover	2560276 (10 pieces x 2.5m)

Subject to change without notice

Wiring diagram

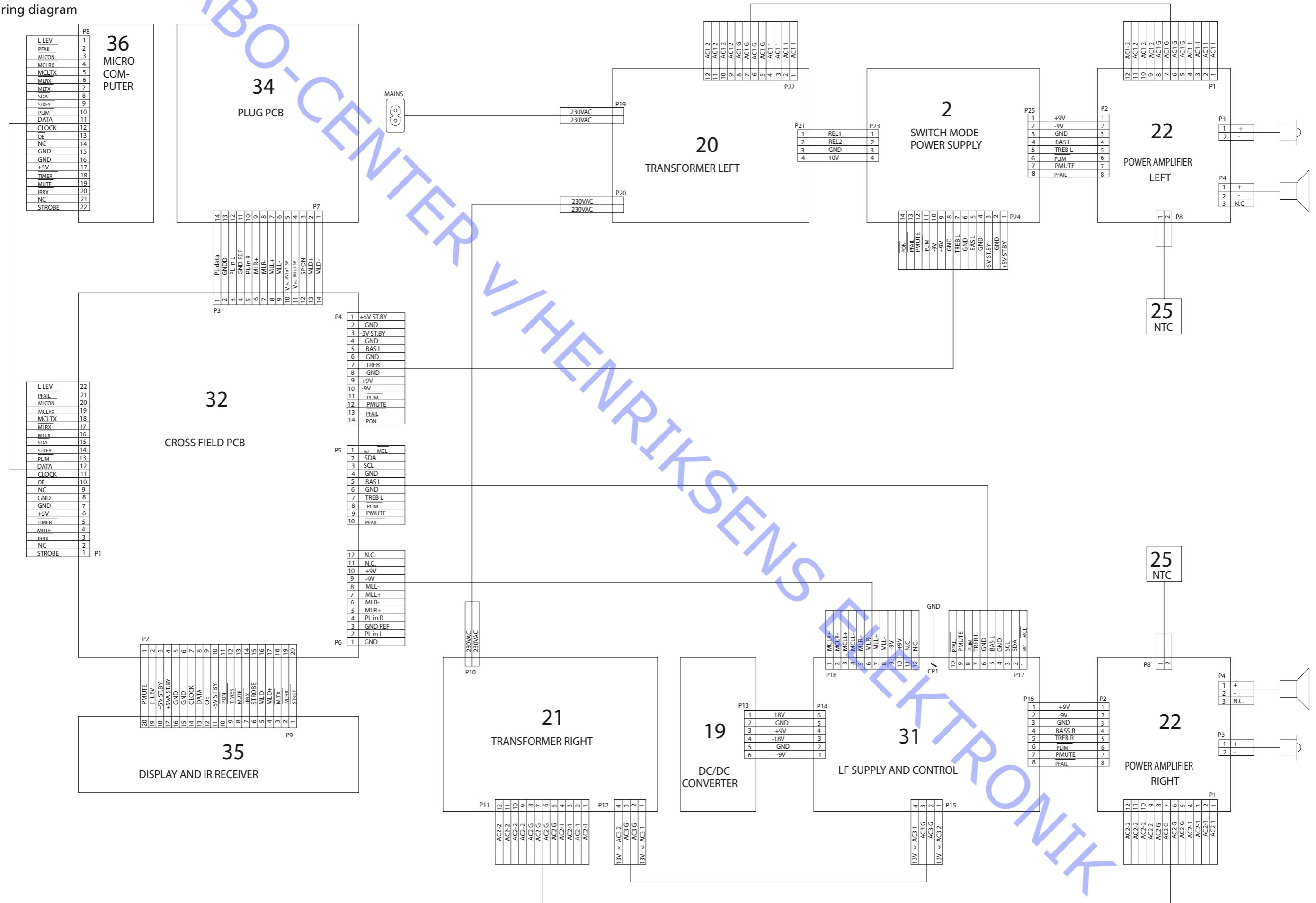

ABO-CENTER V/HENRIKSENS ELEKTRONIK

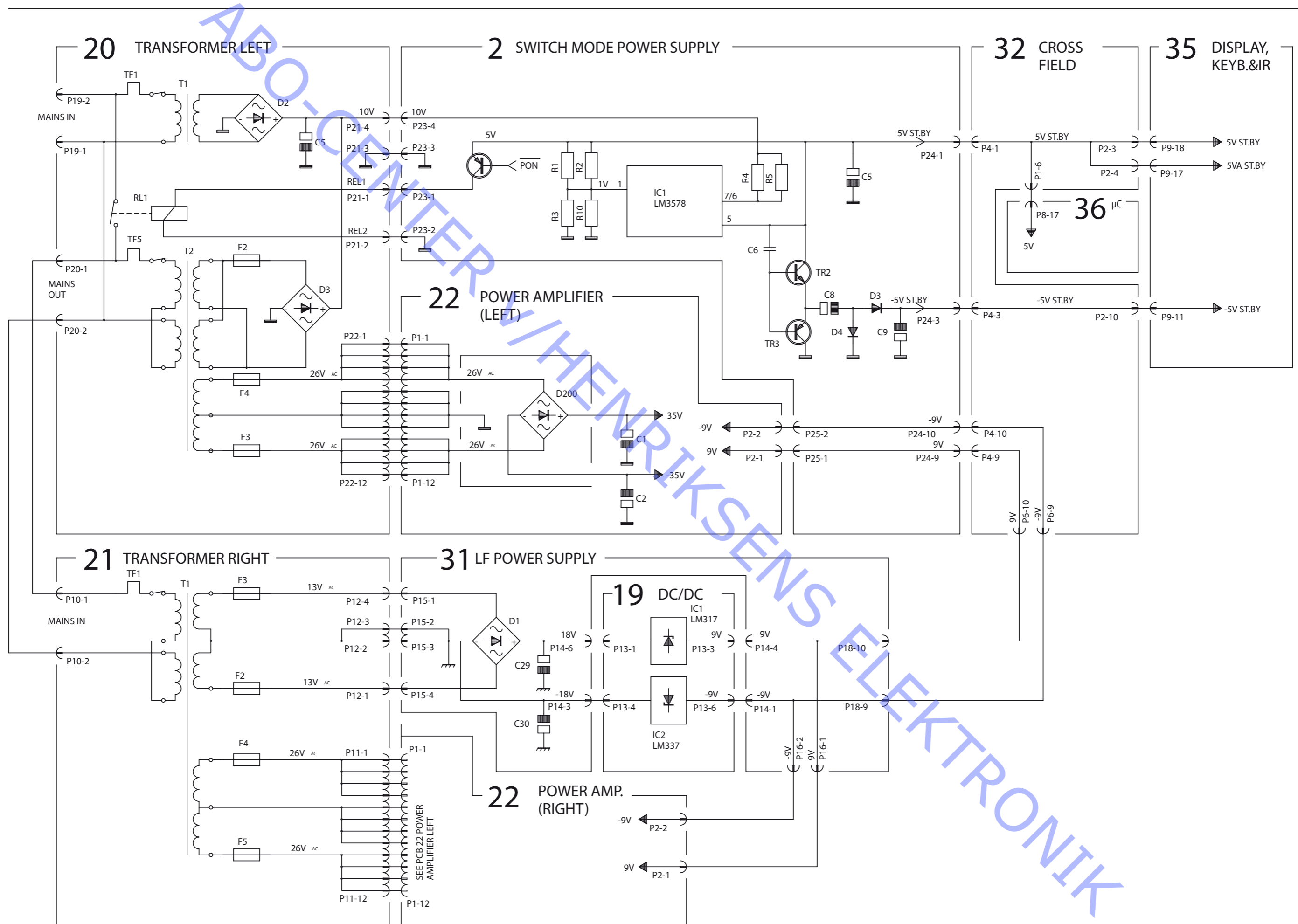

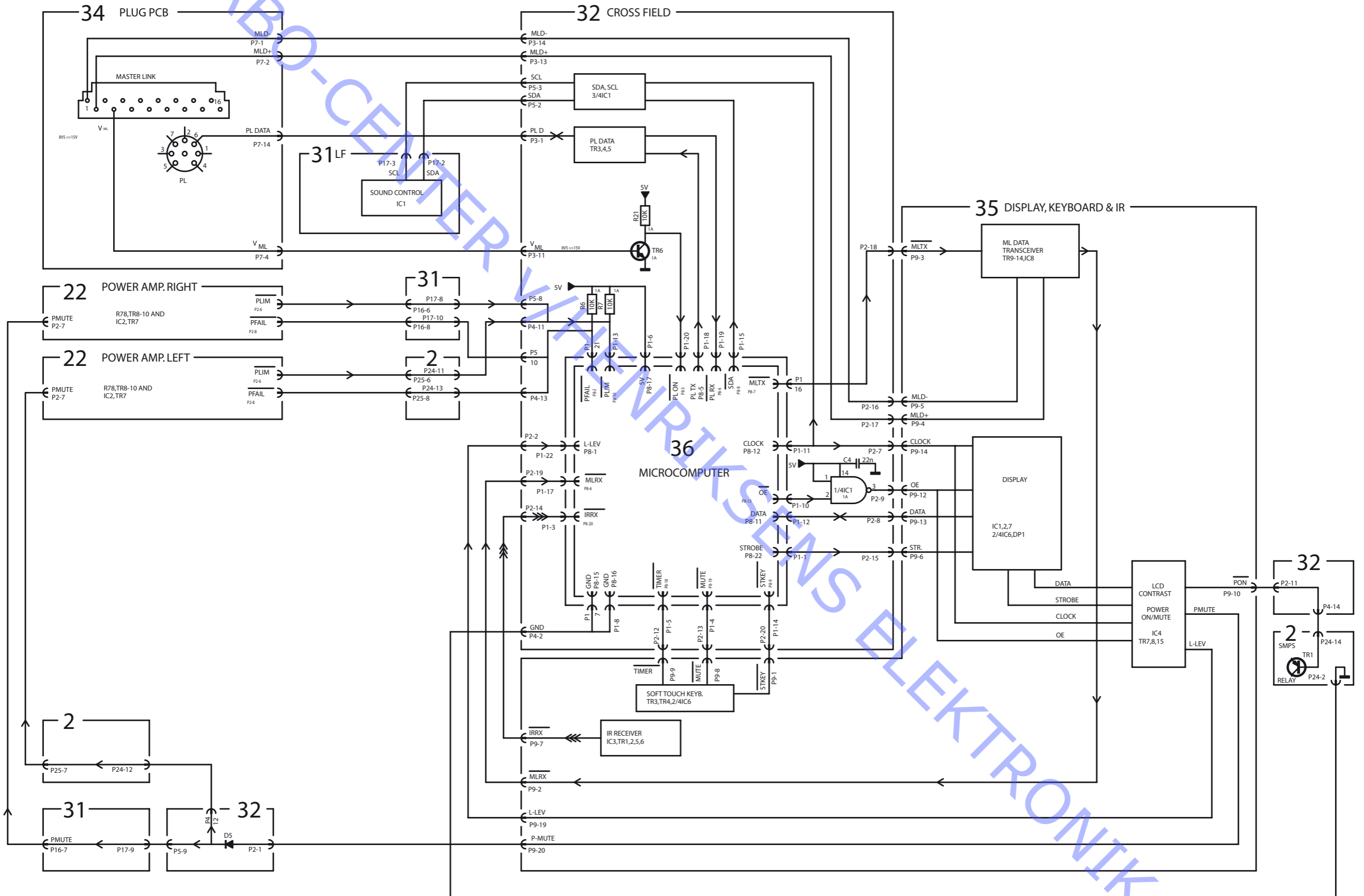

Block diagram for Power amplifier

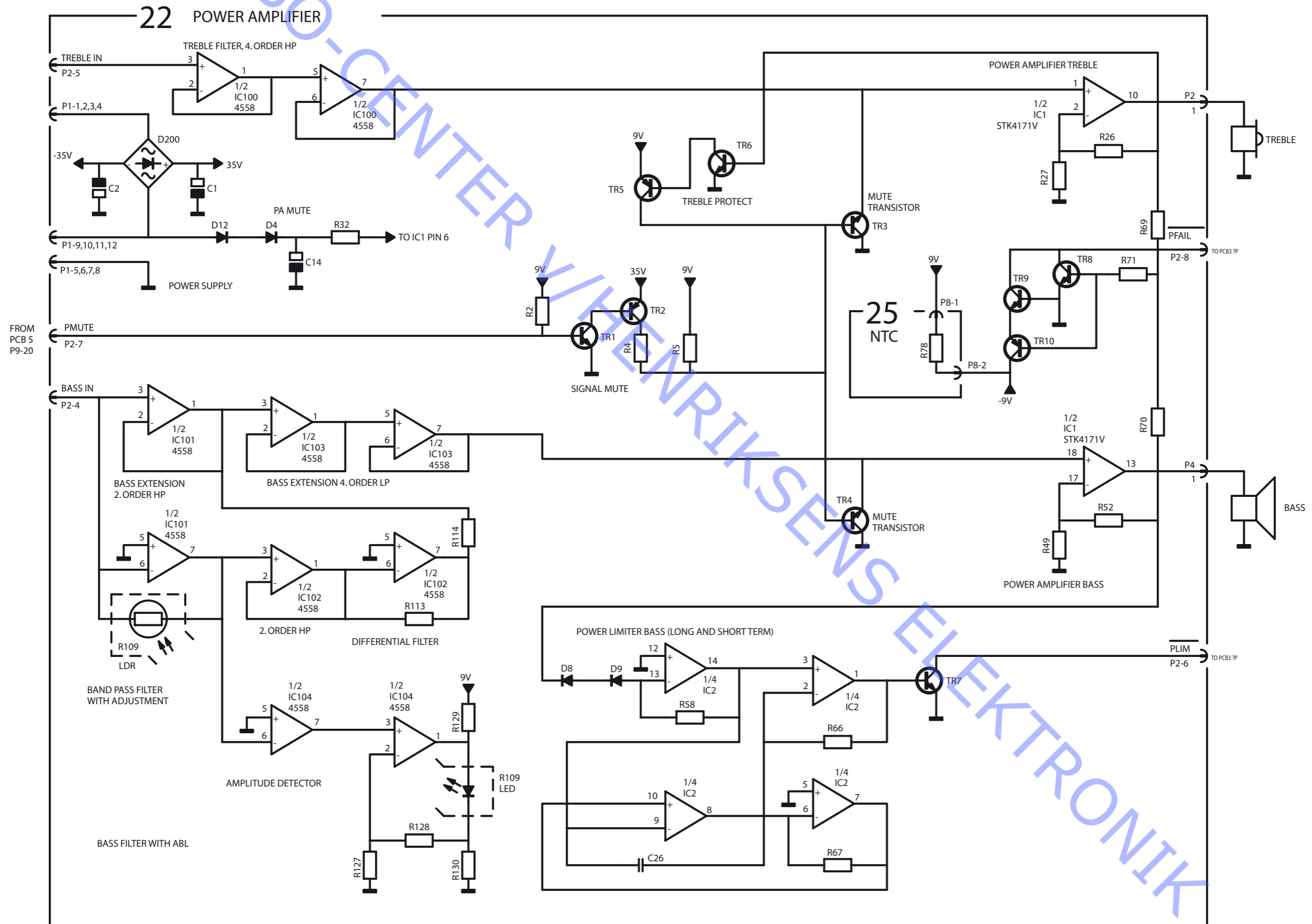

Available parts
BeoLab 3500

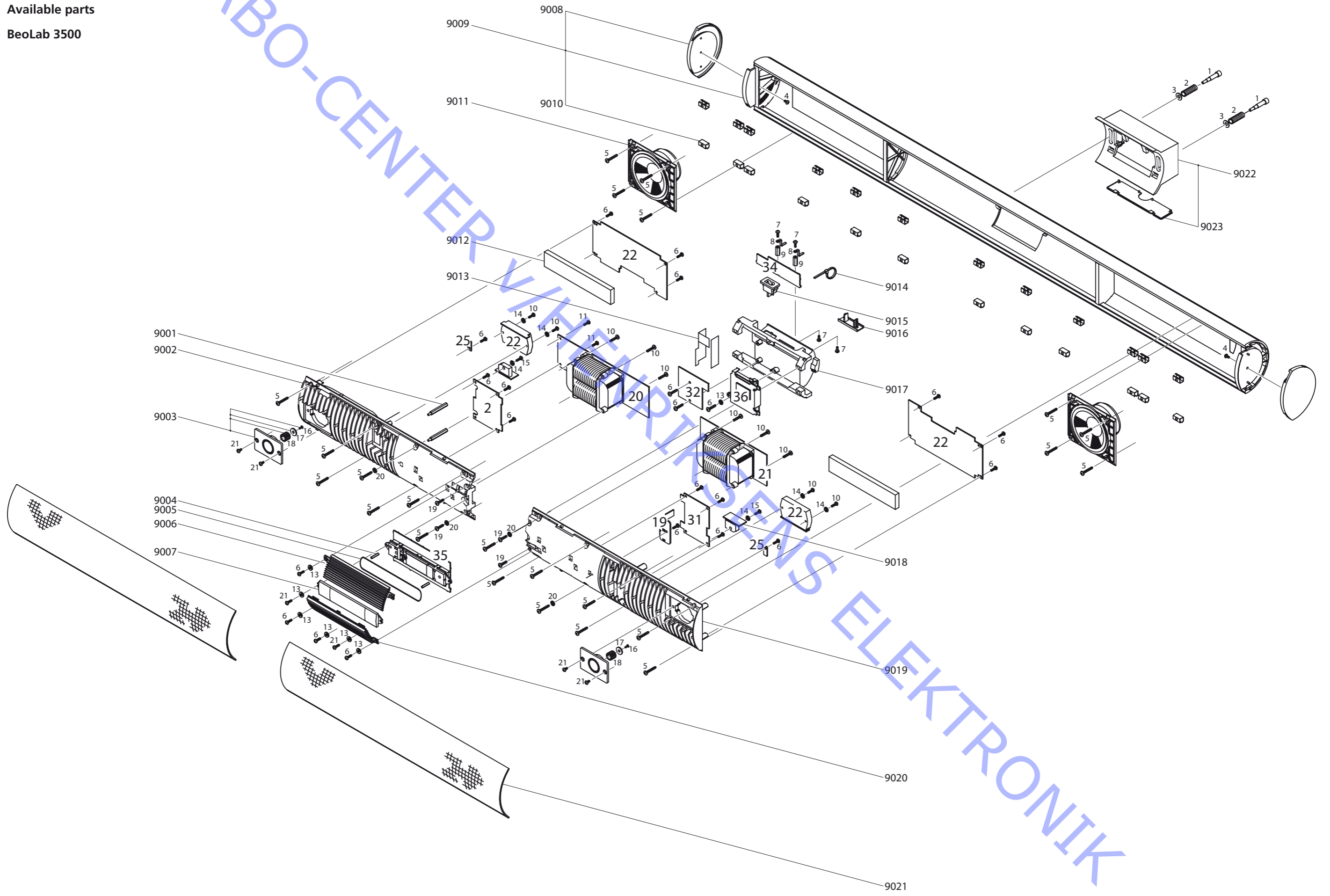

Available parts

9001	2576302	Distance bolt	9012	3332055	Damper
9002	3114422	Chassis	9013	3170300	Insulating piece
9003	8480340	Tweeter	9014	3152214	Wire holder
9004	3907064	Rubber	9015	6276907	Mains socket
9005	3950053	Rubber belt	9016	3164935	Cover
9006	3451207	Front piece	9017	3114406	Chassis f. sockets
9007	3169016	Operating panel	9018	8006108	Rectifier PCB
9008	3459454	Cap, dark grey	9019	3114422	Chassis
	3459108	Cap, black	9020	3451207	Front piece
	3459106	Cap, grey	9021	3451470	Cloth front, dark grey
9009	3430055	Cabinet, dark grey		3451472	Cloth front, silver
	3430056	Cabinet, black		3451244	Cloth front, black
	3430614	Cabinet, grey	9022	3031382	Wall fittings
9010	2816214	Clips	9023	3164920	Cover f. wall fittings
9011	8480259	Woofer			

02Module 8006073 Switch Mode Power Supply

19Module 8006107 DC/DC Converter
 2622423 Insulating piece
 2364066 Rivet
 2816195 Spring clips

20Module 8006091 Transformer left, type 1601, 1607, 1608
 8006092 Transformer left, type 1602, 1605
 8006093 Transformer left, type 1603
 8006094 Transformer left, type 1604

21Module 8006061 Transformer right, type 1601, 1607, 1608
 8006062 Transformer right, type 1602, 1605
 8006063 Transformer right, type 1603
 8006064 Transformer right, type 1604

22Module 8006087 Power Amplifier
 6200044 Band cable

25Module 8006109 NTC PCB

31Module 8002938 LF Supply and Control

32Module 8002935 Cross Field

34Module 8002932 Plug PCB

35Module 8002937 Display, Keyboard and IR Receiver

36Module 8002944 Microcomputer

Survey of screws and washers

1	2046032	Allen screw, 6 x 32.7mm
2	2816267	Spring
3	2622487	Washer
4	2013176	Screw, 3 x 6mm
5	2015154	Screw, 3.5 x 25mm
6	2013188	Screw, 3 x 8mm
7	2036082	Screw, 2.5 x 8mm
8	7530119	Solder tag
9	2640054	Washer
10	2011056	Screw, 3 x 16mm
11	2038111	Screw, 3 x 8mm
13	2622041	Washer
14	2624013	Washer
15	2013177	Screw, 3 x 13mm
16	2038103	Screw, 3 x 12mm
17	2622247	Washer, 3.2 x 10.2 x1mm
18	3358305	Heat sink
19	2015167	Screw, 3.5 x 14mm
20	2625039	Lock washer
21	2011055	Screw, 3 x 10mm

Accessories

3031302 Wall bracket, type 1607
 3031235 Wall bracket
 3390481 Bag with parts f/Wall bracket
 3031333 Wall plate
 3390468 Bag with parts f/Wall plate
 1160611 Table stand
 3390480 Bag with parts f/table stand
 2560276 Cable cover, 10 pieces

Parts not shown

3947547 Foam, 3x19mm x 10m
 3947350 Foam, 3x7mm x 10m
 3947548 Foam, 6x7mm x 10m
 3984215 Heat sink compound
 3040016 Allen key, 4mm
 6100273 Mainscable EU, type 1601
 6100329 Mainscable GB, type 1602
 6100307 Mainscable US, type 1603
 6100247 Mainscable JAP, type 1604
 6100086 Mainscable AUS, type 1605
 6100386 Mainscable KOR, type 1607
 6100047 Mainscable CHK, type 1608

Packing

3392368 Outer carton
 3397921 Foam packing
 3946038 Foam foil

Survey of wire bundles

6276906 Wire bundle, left:
 2P23 - 20P21
 2P24 - 32P4
 2P25 - 22P2
 20P22 - 22P1
 22P3 - Tweeter
 22P4 - Woofer
 6276908 Wire bundle, right:
 31GND - Chassis
 31P14 - 19P13
 31P15 - 21P5
 31P16 - 22P2
 31P17 - 32P5
 31P18 - 32P6
 22P3 - Tweeter
 22P4 - Woofer
 6200239 Varnished tubing PCB set
 6276907 Mains socket wire bundle

Available documentation

See Retail Ordering System

ABO-CENTER V/HENRIKSENS ELEKTRONIK

ABO-CENTER V/HENRIKSENS ELEKTRONIK

Bang & Olufsen
DK-7600 Struer
Denmark

Phone +45 96 84 11 22*
Fax +45 97 85 39 11

06-06 A