

Bang & Olufsen

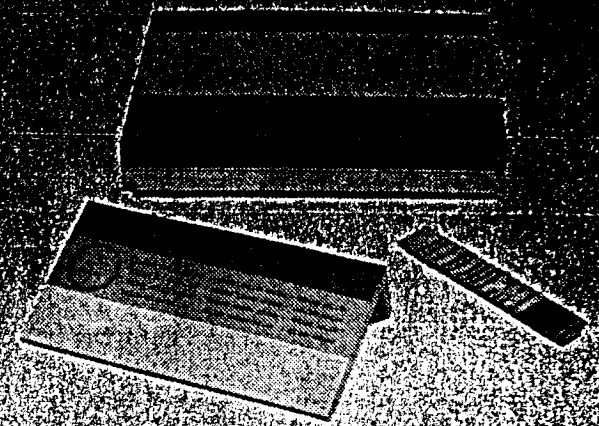

Beomaster 5500

Type 2331, 2332, 2333,
2334, 2335, 2339

Master Control Panel

Type 2048

Audio Terminal

Type 2049

IR-Sensor

Type 2001

SERVICEANVISNING
SERVICE MANUAL

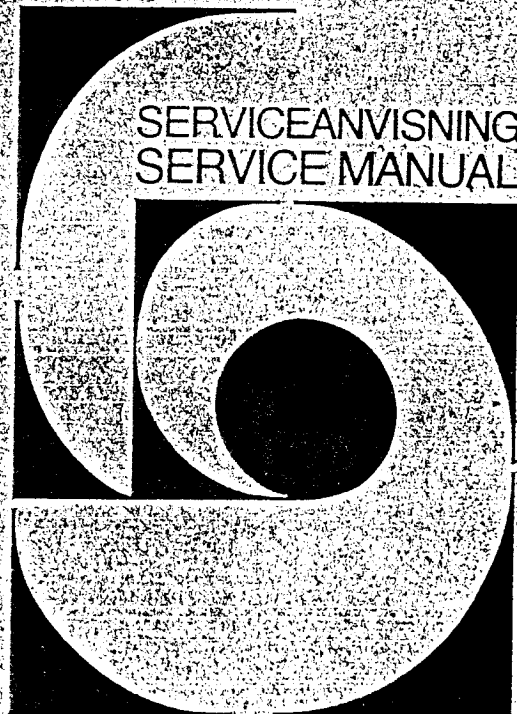

INDHOLD

CONTENTS

Diagrammer.....	1	Circuit diagrams.....	1
Halvlederoversigt.....	2	Semi-conductors.....	2
Elektrisk stykliste.....	3	Electrical parts list.....	3
Mekanisk stykliste.....	4	Mechanical parts list.....	4
Justering.....	5	Adjustment.....	5
Tekniske specifikationer.....	6	Technical specifications.....	6
Adskillelse.....	7	Dismantle.....	7
Servicetips.....	8	Servicetips.....	8
Isolationstest.....	9	Insulation test.....	9
Slutafprovning.....	10	Final test.....	10

1	HF.....	diagr. A page 1-6	12	Master Control, Microcomputer.....	diagr. E page 00
2	Output and Power Supply.....	diagr. B page 7	13	Master Control, IR-left.....	diagr. E page 1-10
3	Preamplifier.....	diagr. B page 1-7	14	Master Control, IR-right.....	diagr. E page 1-10
4	Microcomputer.....	diagr. C page 1-8	15	Master Control, Display.....	diagr. E page 1-10
6	Fan regulation.....	diagr. B page 1-7	17	Tuner - FM.....	diagr. ? page 1-3
9	Display.....	diagr. C page 1-8	20	IR-Sensor.....	diagr. F page 1-11
11	Master Control, keyboard.....	diagr. E page 00	81	Audio Terminal.....	diagr. D page 1-9

20

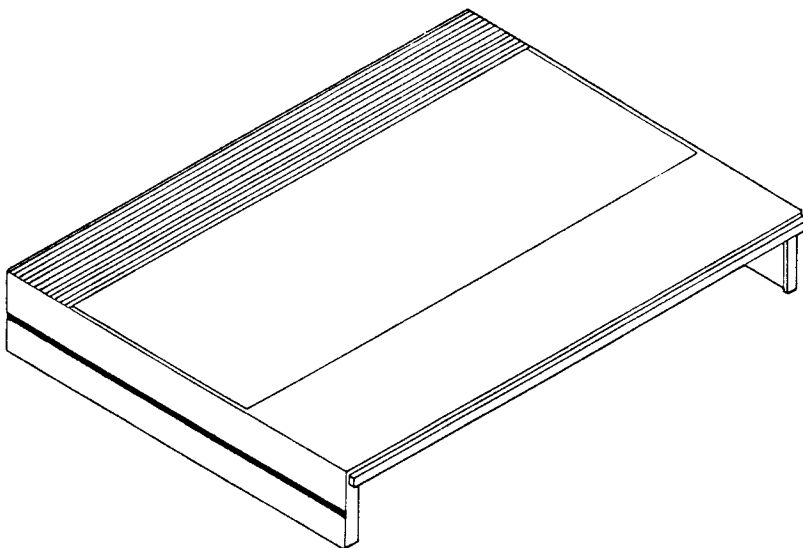

For Service Manuals Contact
MAURITRON TECHNICAL SERVICES
 8 Cherry Tree Rd, Chinnor
 Oxon OX9 4QY
 Tel: 01844-351694 Fax: 01844-352554
 Email: enquiries@mauritron.co.uk

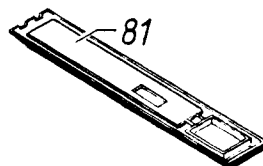
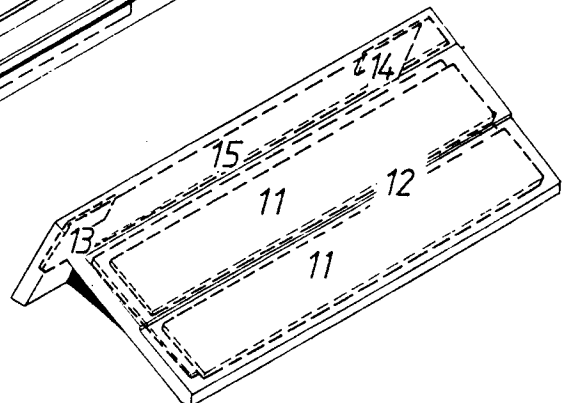
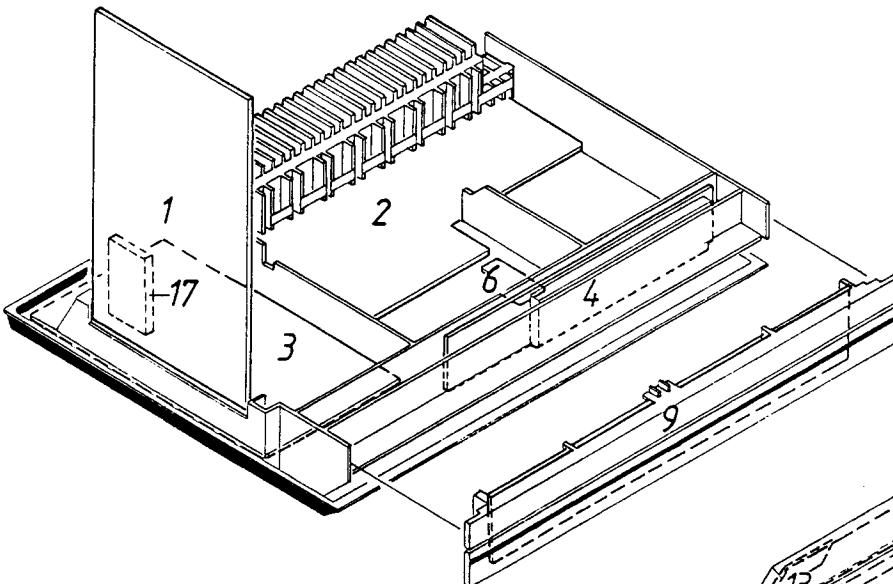

DIAGRAMFORKLARING

På diagrammet er der angivet typenumre på transistorer og IC'er i de tilfælde hvor typenummeret er entydigt for komponenters placering i kredsløbet - f.eks. TR20/BC 557B.

Hvis positionsnummeret er efterfulgt af en stjerne skal reservedelsnummeret benyttes, da denne komponent er specielt udvalgt - f.eks. TR102*.

En pil og spænding viser, hvor forsyningsspændingerne går ind i et print.

Eksempel:

(7CON.) f.eks. ved siden af forsyningsspændingen angiver det antal steder, spændingen går ind på denne diagramside.

Koordinatnumre

De tre største PCB plader er forsynet med et koordinatsystem. Komponenterne på disse PCB plader er forsynet med et koordinatnummer på diagrammet (mindre skrifttype end positions nr.), som fortæller hvilket koordinat, på PCB pladen, de er placeret i. Koordinatnumre for udgangsforstærkerens venstre kanal er angivet i parenteser i diagrammet for højre kanal.

Styrekredsløb

I visse styrekredsløb er den aktive tilstand angivet med en bogstavsbetegnelse (Cr = High med CrO₂ bånd). Hvis betegnelsen er forsynet med negationstegn er den aktive tilstand LOW (Cr = LOW med CrO₂ bånd).

Ledningsforbindelser

Ledningsforbindelserne på diagrammet er samlet i »bundter«. De enkelte ledninger er forsynet med koder, der fortæller hvortil de går.

INTERN FORBINDELSE
PÅ EN DIAGRAMSIDE



INTERNAL CONNECTION
ON ONE DIAGRAM PAGE

Interne forbindelser på en diagramside angives med et tal. Knækket på ledningen viser i hvilken retning den anden ende af ledningen findes.

FORBINDELSE TIL EN ANDEN
DIAGRAMSIDE

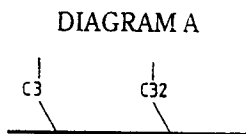

DIAGRAM A

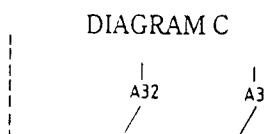

DIAGRAM C

CONNECTION TO ANOTHER
DIAGRAM PAGE

Forbindelsen til en anden diagramside angives med et tal, samt bogstav indikation på det diagram forbindelsen går til.

EXPLANATION OF DIAGRAM

Type numbers of transistors and IC's have been indicated on the diagram in those cases where the type number is unambiguous for the position of the component in a circuitry - e.g. TR20/BC 557B.

If the position number is followed by an asterisk the spare part number **must be used** because this component has been especially selected - e.g. TR102*.

An arrow and the voltage show where the supply voltages are fed to a PCB.

Example:

(7CON.) next to the supply voltage indicates the number of places where to find the voltages in this diagram.

System of Coordinates

The biggest PCB boards are provided with coordinate systems. The components on these PCB boards are provided with a co-ordinate number on the diagram (smaller printing type than the position numbers) indicating in which co-ordinate they are placed on the PCB board.

The co-ordinate numbers for the left channel of the output amplifier are stated in brackets in the diagram for right channel.

Control Circuit

In certain control circuits the active mode has been indicated by means of a letter symbol (Cr = HIGH with CrO₂ tapes). If the symbol has a negation superscript bar the active mode is LOW (Cr = LOW with CrO₂ tapes).

Wiring Connections

The wiring connections on the diagram are assembled in »bundles«. The individual wires are coded to indicate to where they are leading.

Internal connections on a diagram page are indicated by a number. The bend of the wire indicates in which direction the other end of the wire may be found.

Connections to another diagram page are indicated by a number, as well as by a letter of the diagram to which the connections lead.

Symbol for sikkerhedskomponenter



Symbol for Safety Components

Ved udskiftning af komponenter med dette symbol skal der anvendes komponenter med samme reservedelsnummer. Den nye komponent skal monteres på samme måde som den udskiftede.

When replacing components with this symbol components with identical part numbers are to be used. The new component must be fitted in the same way as the one replaced.

MÅLEBETINGELSER

Alle DC spændinger er målt til stel med voltmeter (indre modstand 10 Mohms).
DC spændinger er opgivet i volt (V). Eks. 0.7 V.
Spændinger på diagram A er målt i stilling FM, spændingerne i parentes er målt i stilling MW, spændingerne i firkanter parentes er målt i stilling LW.

Spændingerne på diagram B er målt med 1 W udgangseffekt.
Signalveje er vist for henholdsvis FM, AM, fjernbetjening og for LF højre kanal.

MEASURING CONDITIONS

All DC voltages are measured in relation to chassis with a voltmeter (internal resistor 10 Mohms).
DC voltages are stated in volts (V). Eg. 0.7 V.
Voltages in diagram A are measured in FM mode signal, the voltages in parentheses are measured in MW mode, the voltages in quadrangular parentheses are measured in LW mode.

Voltages in diagram B are measured with 1 W output level.
The signal paths are shown for FM, AM, remote control and AF right channel.

Type 2333 Explanation of the fuse symbols used in the set
Explication de symboles du fusible utilisés dans l'appareil



Replace with same type 5 ampere 250 volts slow acting fuse.
Remplacer par un fusible de même type retardé et de 5 ampères 250 volts.

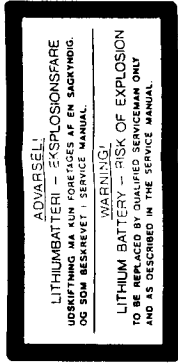

ADVARSEL
Kortslutning og overopladning af visse typer lithium-batterier kan medføre voldsom eksplosion.

Ved udskiftning af lithium-batteriet i dette apparat skal følgende iagttages:

Der skal anvendes batteri af samme fabrikat og type som angivet i denne service manual (se side 4-5).

Batteriet skal monteres nøjagtigt som det originale batteri.

WARNING
Short circuit and overcharging of some types of lithium batteries may result in a violent explosion.

When replacing the lithium battery in this set note the following:

Use only batteries of the same make and type as mentioned in this service manual (see page 4-5).

Place the battery exactly like the old one.

FM TUNER

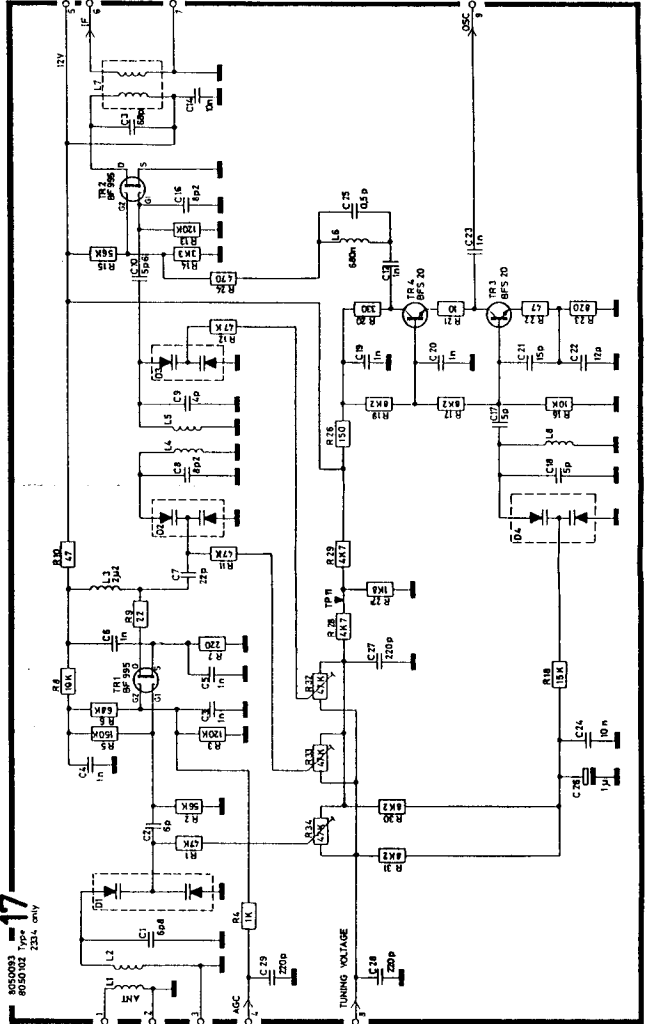

The FM TUNER is a single unit.
What failure in this unit we recommend replacing the whole unit.
However the part nos. of semi-conductors are in the list of semi-conductors.

For Service Manuals Contact
MAURITRON TECHNICAL SERVICES
8 Cherry Tree Rd, Chinnor
Oxon OX9 4QY
Tel: 01844-351694 Fax: 01844-352554
Email: enquiries@mauritron.co.uk

For Service Manuals Contact
MAURITRON TECHNICAL SERVICES
 8 Cherry Tree Rd, Chinnor
 Oxon OX9 4QY
Tel:- 01844-351694 Fax:- 01844-352554
Email:- enquiries@mauritron.co.uk

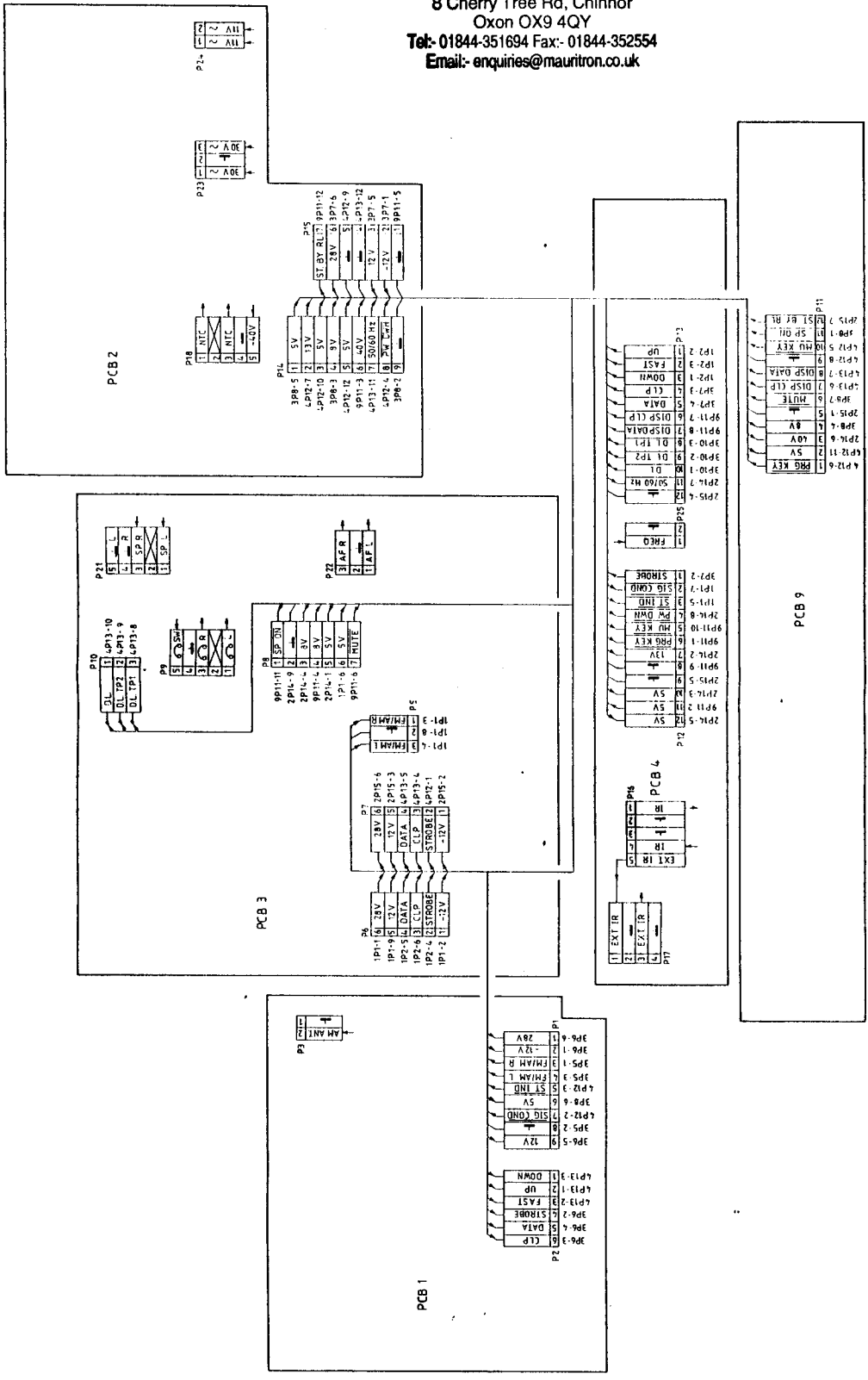
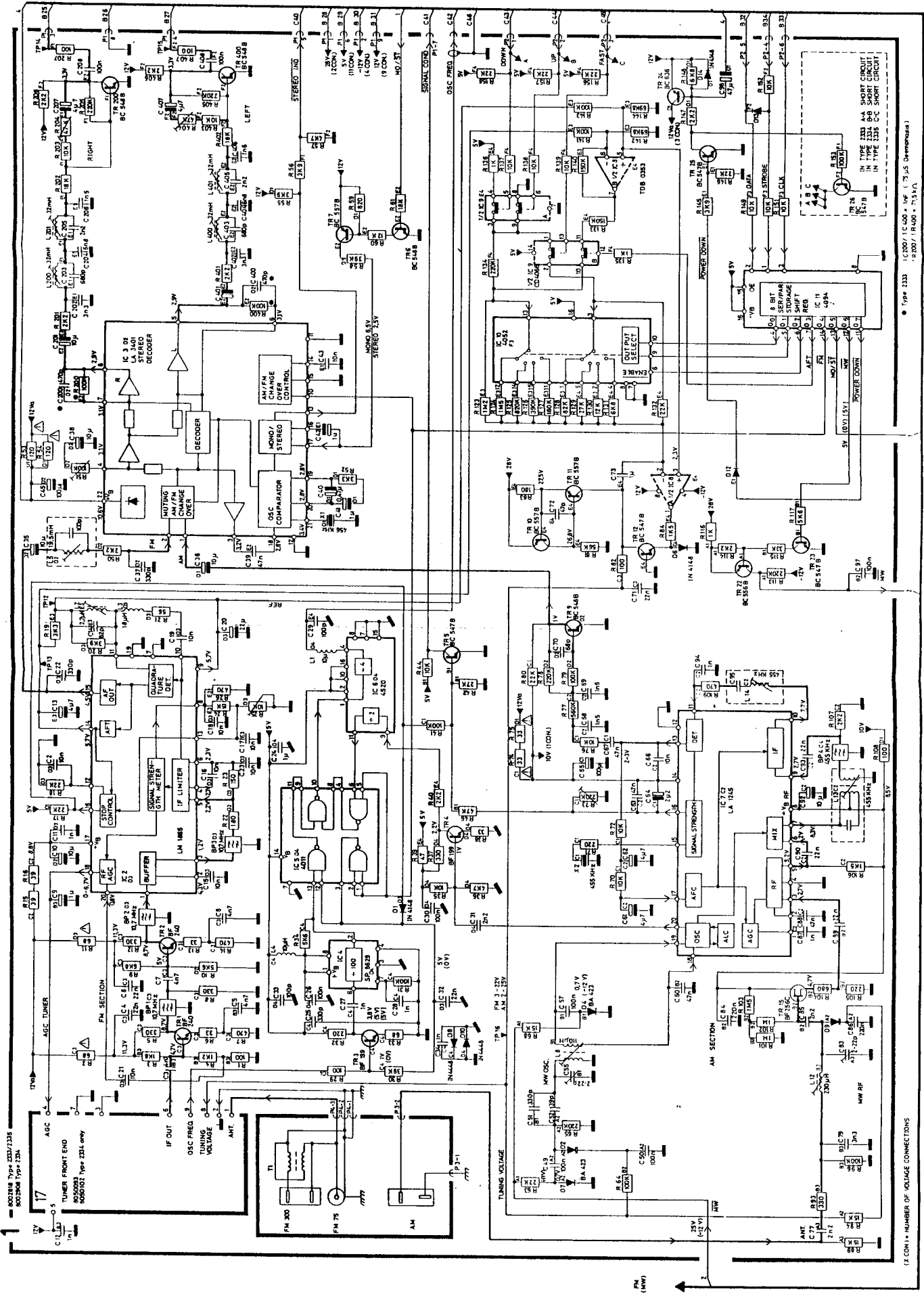

DIAGRAM A AM-FM, TUNER, IF, STEREO DECODER (Type 2333, 2334, 2335)



(1 CON) = NUMBER OF VOLTAGE CONNECTIONS

● TYPE 2333 (1200/1C-00) + ICF (1.75 J&S OVERMOS) + ICF (1.75 J&S OVERMOS) + ICF (1.75 J&S OVERMOS)

DIAGRAM B RIAA AMPL., INPUT SELECT, VOLUME AND TONE CONTROL, OUTPUT AMPL., POWER SUPPLY
8002814 ONLY, TYPE 2333

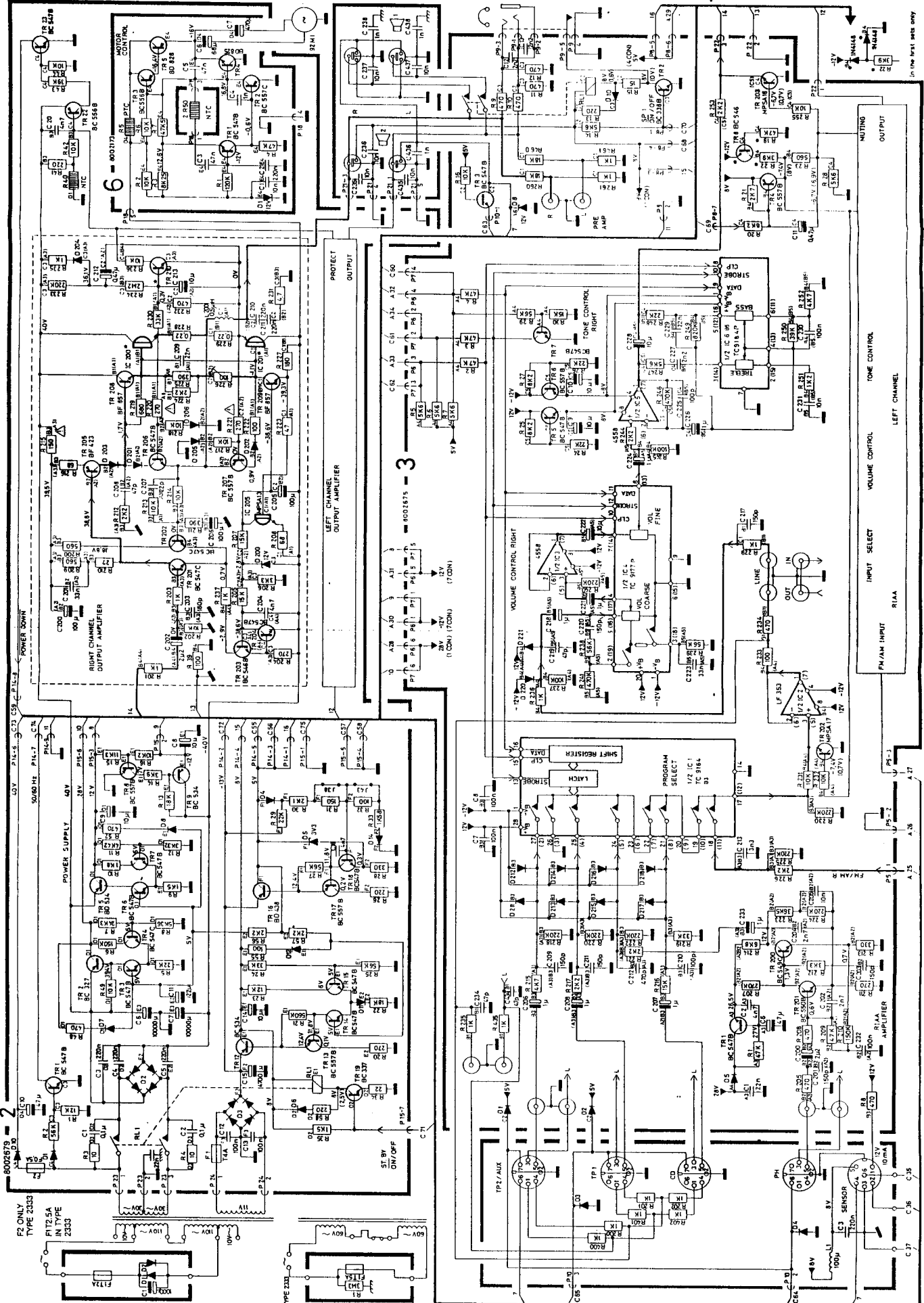

IN THE NEXT PAGE ONLY

BLOCK DIAGRAM

For Service Manuals Contact
MAURITRON TECHNICAL SERVICES
8 Cherry Tree Rd, Chinnor
Oxon OX9 4QY
Tel:- 01844-351694 Fax:- 01844-352554
Email:- enquiries@maurtron.co.uk

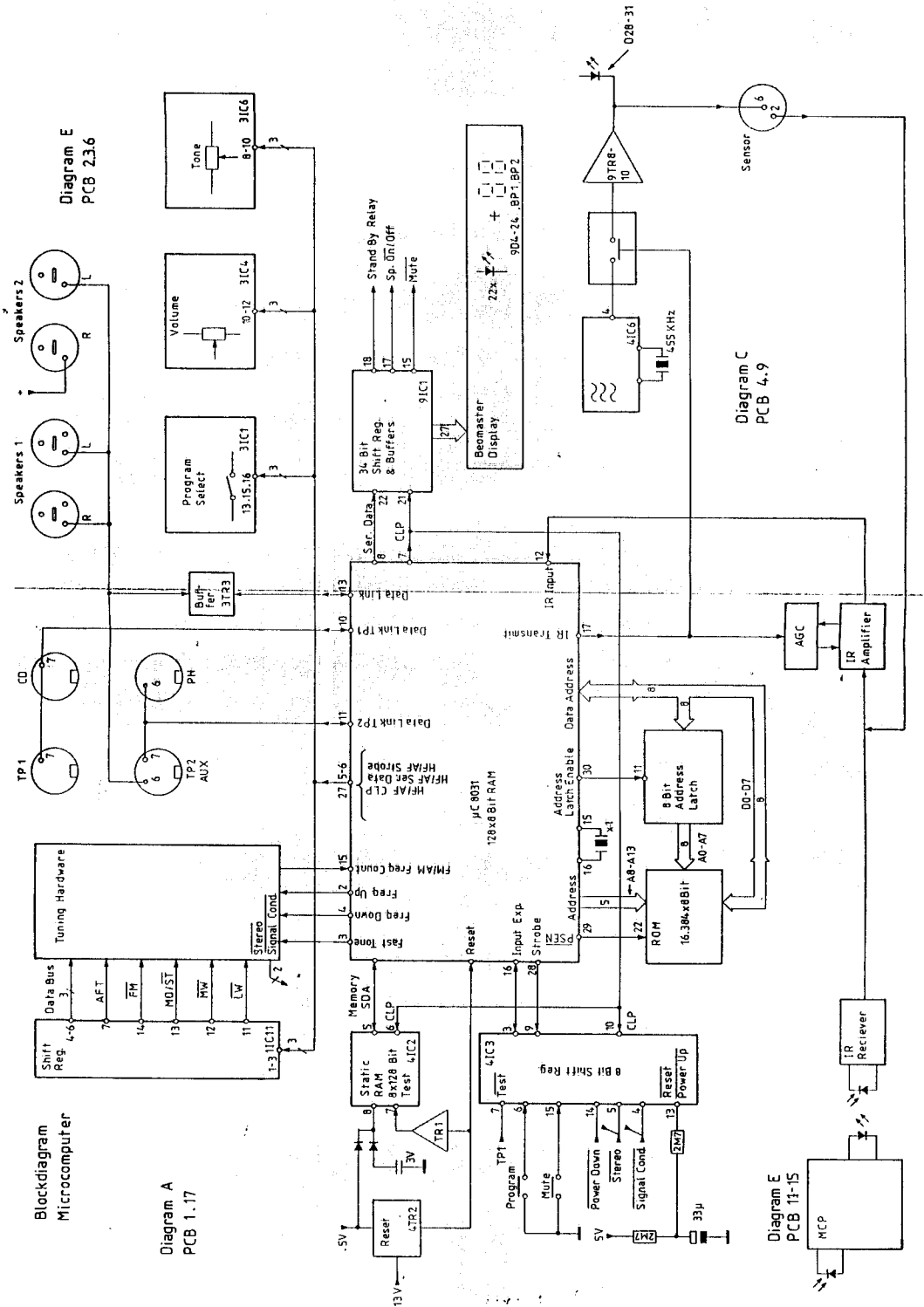

Blockdiagram
Microcomputer

Diagram A
PCB 1..17

Diagram E
PCB 23.6

Diagram C
PCB 4..9

Diagram E
PCB 11-15

BLOCK DIAGRAM

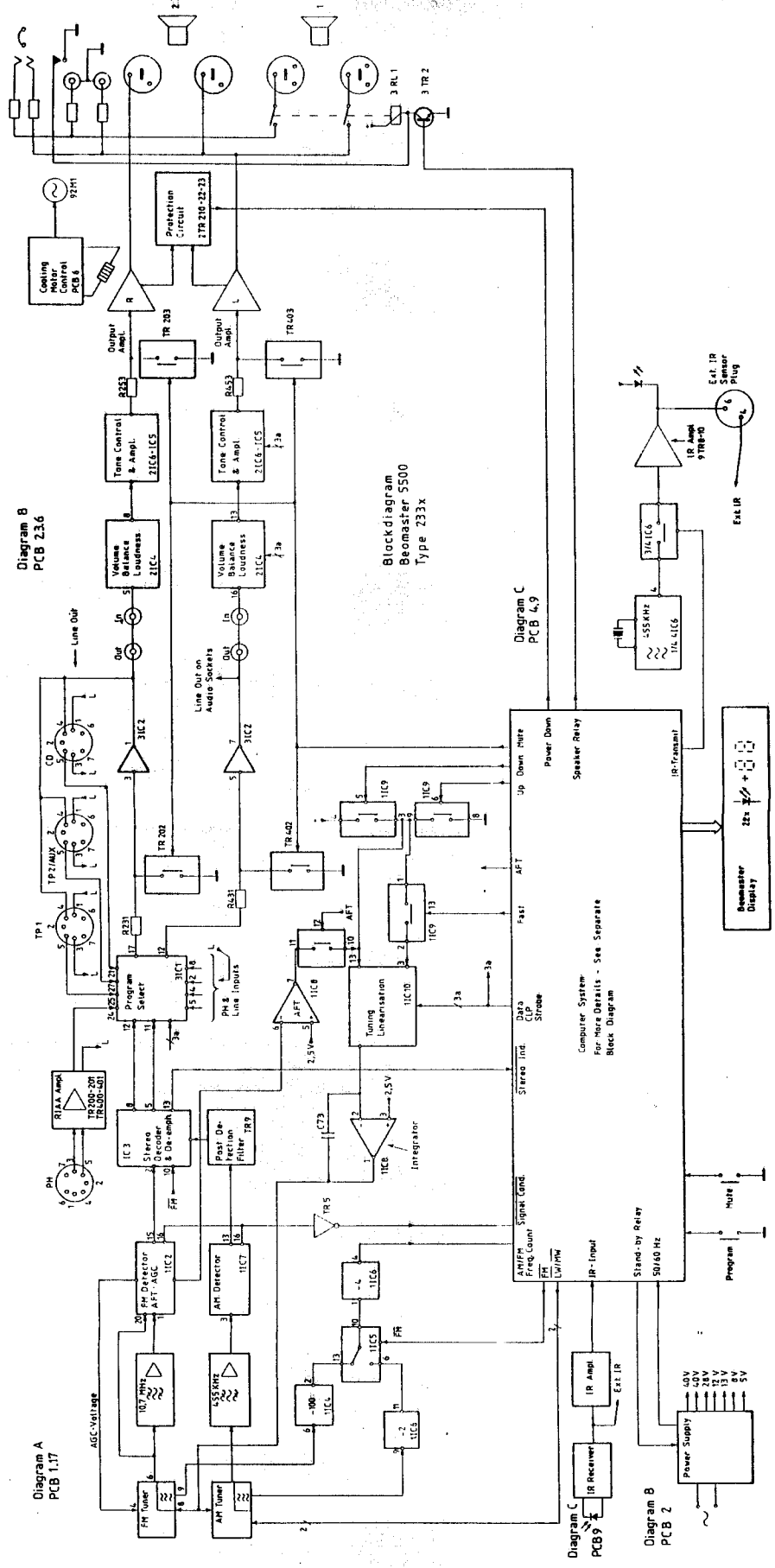

SEMI-CONDUCTORS

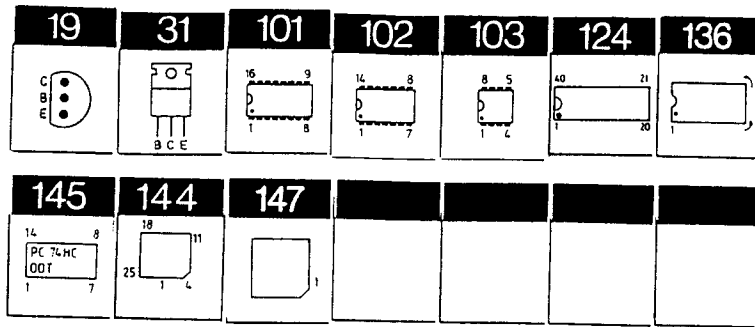

List of IC's

For Service Manuals Contact
MAURITRON TECHNICAL SERVICES
 8 Cherry Tree Rd, Chinnor
 Oxon OX9 4QY
 Tel: 01844-351694 Fax: 01844-352554
 Email: enquiries@mauritron.co.uk

1IC2	8340756	136	LM 1865	3IC6 Δ	8340761	136	TC 9184
1IC3	8340758	136	LA 3401	4IC1 Δ	8340753	136	uC 8031
1IC4	8340492	103	SP 8629 DP	4IC2 Δ	8340616	136	PCD 8571P
1IC5 Δ	8340245	102	CD 4011 BCN	4IC3 Δ	8340276	101	CD 4021 CN
			102 CD 4011 BE			101	HEF 4021 BP
			102 HEF 4011 BE			101	MC 14021 BCP
			102 MC 14011BCP	4IC4 Δ	8340934	136	TMM 27128
1IC6 Δ	8340491	101	HEF 4520BP	4IC5 Δ	8340777	136	74HCT573
1IC7	8340757	136	LA 1245	4IC6 Δ	8340373	136	MC 140001B
1IC8	8340763	136	LF 353- TL072	9IC1 Δ	8340467	124	MM5450 N
1IC9 Δ	8340202	102	CD 4066 BCN	12IC1 Δ	8340884	147	HMC S4040
			102 HEF 4066 BP	12IC2	8340141	103	LM 741
			102 MC 14066 BCP	81IC30 Δ	8340787	144	μP MC 16805
			102 MSM 4066 RS	81IC31 Δ	8340858	145	IC SMD
1IC10 Δ	8340602	101	CD 4052 BC				74HC00
			101 HEF 4052 BP				
			101 MC 14052 BCP				
1IC11 Δ	8340782	101	4094				
2IC200/	8340470	31	BDV 65B				
400*							
2IC201/	8340469	31	BDV 64B				
401*							
2IC205/	8340400	19	MPSA 13				
405							
3IC1 Δ	8340759	136	TC 9164				
3IC2	8340763	136	LF 353 - TL072				
3IC3	8340790	103	4558				
3IC4 Δ	8340760	136	TC 9177				
3IC5	8340790	103	4558				

- Δ Statisk elektricitet kan ødelægge komponenten
- Δ Static electricity may destroy the component
- Δ Statische Elektrizität die Komponente zerstören kann
- * Speciel udvalgt eller bearbejdet eksemplar
- * Specially selected or adapted sample
- * Speziell ausgewähltes und bearbeitets Exemplar

List of Transistors

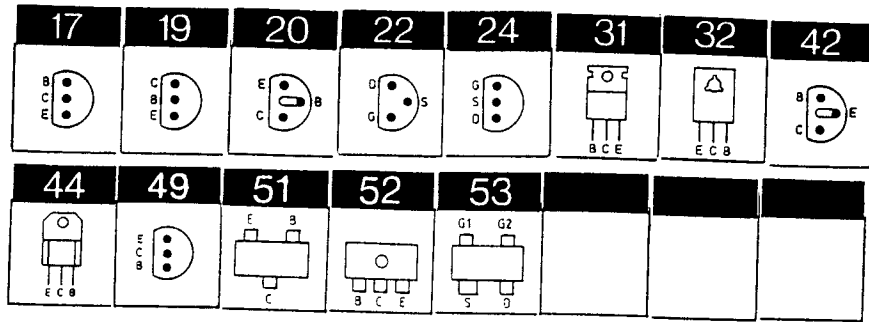

1TR1-2	8320311	42	BF 240	2TR6-7	8320097	20	BC 547B
1TR3-4	8320281	42	BF 199	2TR8	8320152	20	BC 557B
1TR5	8320097	20	BC 547B	2TR9-12	8320369	31	BD 534
1TR6	8320108	20	BC 548B	2TR13	8320152	20	BC 557B
1TR7	8320152	20	BC 557B	2TR14-15	8320097	20	BC 547B
1TR9	8320108	20	BC 548B	2TR16	8320428	32	BD 438
1TR10-11	8320152	20	BC 557B	2TR17	8320152	20	BC 557B
1TR12	8320097	20	BC 547B	2TR18	8320097	20	BC 547B
1TR13	8320329	20	BC 338-25/18	2TR19	8320295	20	BC 337-25/18
1TR14*Δ	8320396	24	MPF 4392 2N 4395 2N 5639	2TR22	8320242	20	BC 556B
1TR15 Δ	8320535	22	BF 256C	2TR23	8320097	20	BC 547B
1TR20	8320242	20	BC 556B	2TR201-	8320377	20	BC 547C 202
1TR21	8320097	20	BC 547B	2TR401-402			
1TR22	8320242	20	BC 556B	2TR203/	8320237	20	BC 546B 403
1TR23	8320097	20	BC 547B	2TR204/	8320097	20	BC 547B 404
1TR24	8320640	49	BC 636	2TR205/	8320631	17	BF 423 405
1TR25	8320097	20	BC 547B	2TR206/	8320097	20	BC 547B 406
1TR200/	8320108	20	BC 548B 400	2TR207/	8320152	20	BC 557B 407
2TR1	8320097	20	BC 547B	2TR208-	8320646	44	BF 858 209
2TR2	8320316	20	BC 327-25/18	2TR408/409			
2TR3	8320097	20	BC 547B	2TR210/	8320546	49	BF 422 410
2TR4	8320377	20	BC 547C				
2TR5	8320369	31	BD 534				

3TR1	8320097	20	BC 547B
3TR2	8320329	20	BC 338-25/18
3TR3	8320097	20	BC 547B
3TR4	8320152	20	BC 557B
3TR5	8320152	20	BC 547B
3TR6	8320152	20	BC 557B
3TR7	8320097	20	BC 547B
3TR200/ 400	8320221	20	BC 549C
3TR201/ 401	8320344	20	BC 550B
3TR202/ 402*	8320639	49	MPSA 17
3TR203/ 403*	8320366	19	MPSA 16
4TR1	8320108	20	BC 548B
4TR2	8320104	20	BC 558B
4TR5-6	8320108	20	BC 548B
4TR7	8320104	20	BC 558B
4TR8	8320311	42	BF 240
4TR9	8320104	20	BC 558B
4TR10-11	8320108	20	BC 548B
6TR1	8320097	20	BC 547B
6TR2	8320540	20	BC 557B
6TR3	8320242	20	BC 556B
6TR4	8320542	44	BD 825-16
6TR5	8320541	44	BD 828-10
9TR2	8320095	20	BC 549B
9TR3	8320311	42	BF 240
9TR8-9	8320237	20	BC 546B
9TR10	8320682	32	BD 788

12TR1	8320108	20	BC 548B
12TR2	8320104	20	BC 558B
12TR3	8320311	42	BF 240
12TR4-5	8320108	20	BC 548B
12TR6	8320104	20	BC 558B
12TR7	8320108	20	BC 548B
12TR11	8320104	20	BC 558B
12TR12	8320450	17	BC 369
12TR13	8320104	20	BC 558B
12TR14	8320450	17	BC 369
12TR15	8320104	20	BC 558B
12TR16	8320450	17	BC 369
12TR17	8320104	20	BC 558B
12TR18	8320450	17	BC 369
12TR19	8320329	20	BC 338-25/18
12TR20- 25	8320108	20	BC 548B
12TR26	8320640	49	BC 636
12TR27	8320108	20	BC 548B
12TR28	8320640	49	BC 636
12TR29	8320108	20	BC 548B
12TR30	8320640	49	BC 636
12TR31	8320108	20	BC 548B
12TR32	8320640	49	BC 636
12TR33	8320108	20	BC 548B
12TR34	8320640	49	BC 636
12TR35	8320108	20	BC 548B
12TR36- 39	8320104	20	BC 558B

12TR40- 41	8320108	20	BC 548B
13TR1	8320311	42	BF 240
13TR2	8320095	20	BC 549B
14TR1	8320311	42	BF 240
14TR2	8320095	20	BC 549B
15TR1-30	8320615	51	BC 848B
17TR1-2	8320610	53	BF 995
17TR3-4	8320672	53	BFS 20
20TR1-3	8320424	17	BC 368
20TR4-5	8320095	20	BC 549B
20TR6	8320311	42	BF 240
20TR7	8320069	20	BC 559B
81TR30- 31	8320615	51	BC 848B
81TR32	8320616	51	BC 858B
81TR33	8320684	52	BC 869
81TR34	8320616	51	BC 858B
81TR35	8320684	51	BC 869

For Service Manuals Contact
MAURITRON TECHNICAL SERVICES
 8 Cherry Tree Rd, Chinnor,
 Oxon OX9 4QY
 Tel: 01844-351694 Fax: 01844-352554
 Email: enquiries@mauritron.co.uk

- Δ Statisk elektricitet kan ødelægge komponenten
- Δ Static electricity may destroy the component
- Δ Statische Elektrizität die Komponente zerstören kann
- * Speciel udvalgt eller bearbejdet eksemplar
- * Specially selected or adapted sample
- * Speziell ausgewähltes und bearbeitetes Exemplar

List of Diodes

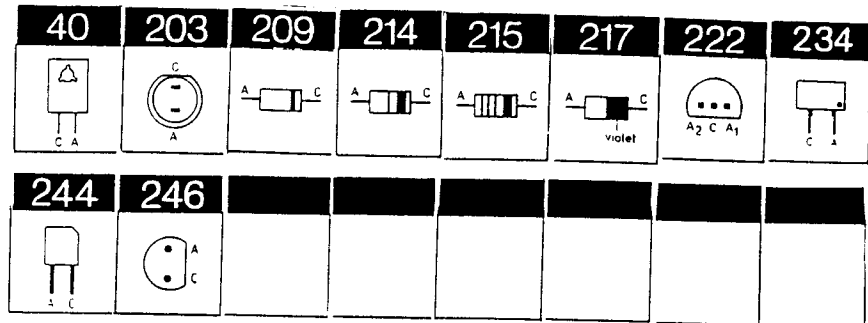

0D1-2	8300023	209	1N4002	2D11-14	8300058	217	SFD 184
						209	1N 4148
1D1 NB!	8300058	217	SFD 184			215	1N 4148
		209	1N 4148				
		215	1N 4148	2D200-	8300407	209	BZX79B 12
1D2	8300384	234	KV 1226Y	203		209	BZX29B 12
				2D400-		209	ZPD 12V
1D3-5	8300385	209	BA 423	403			
				2D204/	8300409	214	BAV 20
1D6	8300058	217	SFD 184	404			
		209	1N 4148	2D205-	8300058	217	SFD 184
		215	1N 4148	206		209	1N 4148
1D7	8300385	209	BAA 423	2D405-		215	1N 4148
				406			
1D8	8300212	209	1N 4448	3D1-5	8300058	217	SFD 184
1D9 NB!	8300384	234	KV 1226Y			209	1N 4148
						215	1N 4148
1TR10	8300212	209	1N 4448	3D8	8300407	209	BZX79B 12
1D11-13	8300058	217	SFD 184			209	BZX83B 12
		209	1N 4148			209	ZPD 12V
		215	1N 4148	3D10	8300058	217	SFD 184
2D1	8300058	217	SFD 184	3D220-		209	1N 4148
		209	1N 4148	221			
		215	1N 4148	3D420-		215	1N 4148
2D2	8300011		B80 C5000/3300	421			
2D3	8300297		B80 C3700/2200	4D1	8300296	209	BZX79B 5V6
2D4	8300058	217	SFD 184			209	BZX83B 5V6
		209	1N 4148			209	ZPD 5.6V
		215	1N 4148	4D2-12	8300058	217	SFD 184
2D5	8300541		3V3 2% 0.4W			209	1N 4148
						215	1N 4148
2D6-8	8300058	217	SFD 184	6D1	8300407	209	BZX79B 12
		209	1N 4148			209	BZX83B 12
		215	1N 4148			209	ZPD 12V
2D10	8300023	209	1N 4002	9D1	8002681		BPW 82

9D4-25	8330183	40	LED Green	15D1-79	8330152	246	LED reed
9DP1-2	8330131		HD 1075R/ P 100PA	15D85-97	8330151	246	LED Green
9D28-31	8330140	203	TSHA 5502	15DP1-5	8330131		HD 1075R / P 100PA
12D1-19	8300058	217	SFD 184 209 1N 4148 215 1N 4148	17D1-4	8300308	222	BB 204 blue
12D20	8300404	209	BZX79B 12 209 BZX83B 12 209 ZPD 12V	20D4	8300058	217	SFD 184 209 1N 4148 215 1N 4148
12D24-33	8300058	217	SFD 184 209 1N 4148 215 1N 4148	20D5	8330145	244	BPW 82
13D1	8330145	244	BPW 82	20D6	8300058	217	SFD 184 209 1N 4148 215 1N 4148
13D2-3	8330140	203	TSHA 5502	81D30-36	8300482	217	LL 4148
14D1	8330145	244	BPW 82	81D37-38	8330140	203	TSHA 5502
14D2-3	8330140	203	TSHA 5502	81D39	8300482	217	LL 4148

NB! 1D2 and 1D9 are made in sets of two and therefore they both have to be replaced.

For Service Manuals Contact
MAURITRON TECHNICAL SERVICES
 8 Cherry Tree Rd, Chinnor
 Oxon OX9 4QY
 Tel:- 01844-351694 Fax:- 01844-352554
 Email:- enquiries@mauritron.co.uk

LIST OF ELECTRICAL PARTS

Resistors not mentioned are standard

PCB 1,
8002671 HF type 2331/32
8002818 HF type 2333/35
8002908 HF type 2334

* only type 2333/34

For Service Manuals Contact
MAURITRON TECHNICAL SERVICES
8 Cherry Tree Rd, Chinnor
Oxon OX9 4QY
Tel: 01844-351694 Fax: 01844-352554
Email: enquiries@mauritron.co.uk

0R1	5000194	3.3 M Ω 10% 1/2W			
0C1	4200421	100 μ F -10+50% 63V			
0F1	6600009	Fuse 2A-T/250	0F1	6600019	Fuse 5A
R25	5370074	10 k Ω 20% 1W	R142	5020336	69.8 k Ω 1% 1/4W
R51	5370128	100 k Ω 20% 0.1W	R143	5020263	100 k Ω 1% 1/4W
R73	5370156	220 k Ω 20% 0.1W	R200*	5020257	71.5 k Ω 1% 1/4W
R141	5020263	100 k Ω 1% 1/4W	R204	5370061	47 k Ω 20% 0.1W
C2	4010041	10 nF -20+80% 40V	C56	4340003	5.5-65 pF
C3	4010063	4.7 nF 10% 63V	C57	4130179	100 nF 20% 63V
C4	4010076	22 nF -20+80% 40V	C58	4130179	100 nF 20% 63V
C5	4010063	4.7 nF 10% 63V	C59	4130215	220 nF 20% 63V
C6	4010076	22 nF -20+80% 40V	C60	4130210	47 nF 20% 63V
C7	4010063	4.7 nF 10% 63V	C61	4200477	4.7 μ F 20% 25V
C8	4010063	4.7 nF 10% 63V	C62	4200477	4.7 μ F 20% 25V
C9	4200426	1 μ F 20% 50V	C63	4130210	47 nF 20% 63V
C10	4200431	10 μ F 20% 16V	C64	4200423	2.2 μ F 20% 50V
C11	4010027	1 nF 10% 63V	C65	4200628	100 μ F 20% 16V
C12	4010027	1 nF 10% 63V	C66	4010041	10 nF -20+80% 40V
C13	4200477	4.7 μ F 20% 25V	C67	4130210	47 nF 20% 63V
C14	4000199	82 pF 5% 63V	C68	4100210	1.5 nF 5% 63V
C15	4010041	10 nF -20+80% 40V	C69	4100210	1.5 nF 5% 63V
C16	4010041	10 nF -20+80% 40V	C70	4000215	68 pF 5% 63V
C17	4010041	10 nF -20+80% 40V	C71	4010076	22 nF -20+80% 40V
C18	4010041	10 nF -20+80% 40V	C72	4000057	47 pF 5% 63V
C19	4010041	10 nF -20+80% 40V	C73	4130136	1 μ F 20% 100V
C20	4200480	22 μ F 20% 10V	C76	4100247	1.8 nF 5% 63V
C21	4010041	10 nF -20+80% 40V	C77	4010061	2.2 nF 10% 63V
C22	4010062	330 pF 10% 63V	C78	4130179	100 nF 20% 63V
C23	4010041	10 nF -20+80% 40V	C79	4130210	1.5 nF 5% 63V
C24	4130310	1 μ F 10% 50V	C79*	4100238	3.3 nF 5% 63V
C25	4010062	330 pF 10% 63V	C80	4130179	100 nF 20% 63V
C26	4130179	100 nF 20% 63V	C81	4340003	5.5-65 pF
C27	4010027	1 nF 10% 63V	C82	4130179	100 nF 20% 63V
C28	4010027	1 nF 10% 63V	C83	4340002	2-22 pF
C29	4000069	100 pF 5% 63V	C84	4130215	220 nF 20% 63V
C30	4130179	100 nF 20% 63V	C85	4010061	2.2 nF 10% 63V
C31	4010061	2.2 nF 10% 63V	C86	4130215	220 nF 20% 63V
C32	4010076	22 nF -20+80% 40V	C87	4010027	1 nF 10% 63V
C33	4000069	100 pF 5% 63V	C88	4130210	47 nF 20% 63V
C34	4200431	10 μ F 20% 16V	C89	4010076	22 nF -20+80% 40V
C36	4200431	10 μ F 20% 16V	C90	4010076	22 nF -20+80% 40V
C37	4010062	330 pF 10% 63V	C92	4200431	10 μ F 20% 16V
C38	4200431	10 μ F 20% 16V	C93	4010076	22 nF -20+80% 40V
C39	4030023	47 nF -20+80% 16V	C94	4010027	1 nF 10% 63V
C40	4200476	0.47 μ F 20% 50V	C96	4130179	100 nF 20% 63V
C41	4200426	1 μ F 20% 50V	C97	4130179	100 nF 20% 63V
C42	4200426	1 μ F 20% 50V	C200	4100209	470 pF 5% 63V
C43	4010041	10 nF -20+80% 40V	C200*	4100236	1 nF 5% 63V
C45	4200628	100 μ F 20% 16V	C201	4200431	10 μ F 20% 16V
C48	4000057	47 pF 5% 63V	C202	4100238	3.3 nF 5% 63V
C49	4130179	100 nF 20% 63V	C203	4100235	680 pF 5% 63V
C50	4130179	100 nF 20% 63V	C204	4100261	6.8 nF 2.5% 63V
C51	4100228	330 pF 5% 63V	C205	4100260	2.2 nF 2.5% 63V
C52	4003135	39 pF 5% 63V	C206	4100210	1.5 nF 5% 63V
C53	4003135	39 pF 5% 63V	C207	4200477	4.7 μ F 20% 25V
C54	4100233	150 pF 5% 63V	C208	4130179	100 nF 20% 63V
C55	4340002	2-22 pF			
L1	8020578	Coil 10 μ H 10%	L8	8020559	Coil osc. MB
L2	8020568	Coil 2.7 μ H	L9	8020560	Coil osc. LB
L3	8020569	Coil 18 μ H 10%	L11	8020558	Coil antenne LB
L4	8020627	Coil 10 μ H 10%	L12	8020557	Coil antenne MB
L5	8022240	Coil 19.5 MH 2%	L13	8020561	Coil 455 Hz

L14	8020562	Coil 455 Hz	L201	8022239	Coil 32 MH 2% 19-38 kHz
L200	8022239	Coil 32 MH 2% 19-38 kHz			

BP1	8030118	10.7 MHz	BP3	8030118	10.7 MHz
BP2	8030118	10.7 MHz	BP4	8030056	455 kHz ± 1 kHz

TU1	8050093	Tuner type 2331/ 32/33/35	TU1	8050102	Tuner type 2334
-----	---------	------------------------------	-----	---------	-----------------

X1	8030087	Crystal 456 kHz ± 1 kHz	X2	8030088	Crystal 455 kHz
----	---------	----------------------------	----	---------	-----------------

P1	7220431	Plug 9/9 pins	P3	7220312	Plug
P2	7220428	Plug 6/6 pins	P4	7210612	Socket

R7	5020239	24.3 kΩ 1% 1/4W	R50	5220036	330 kΩ 10% 1/2W
R8	5020219	5.36 kΩ 1% 1/4W	R211	5010797	390 Ω 2% 1/4W
R11	5020770	4.42 kΩ 1% 1/4W	R214	5020110	10 kΩ 1% 1/4W
R12	5020291	3.32 kΩ 1% 1/4W	R215	5020633	150 Ω 5% 0.35W
R15	5020231	11.3 kΩ 1% 1/4W	R220	5020658	270 Ω 5% 0.3W
R16	5020335	10.2 kΩ 1% 1/4W	R221	5020658	270 Ω 5% 0.3W
R30	5020200	2.1 kΩ 1% 1/4W	R226	5370240	100 Ω 20% 0.1W
R40	5220036	330 kΩ 10% 1/2W	R228	5102016	0.22 Ω 10% 1W
R33	5020194	1.58 kΩ 1% 1/4W	R229	5100334	0.22 Ω 10% 1W

C1	4130103	100 nF 20% 250V	C200	4200368	100 μF -10+100% 63V
C2	4130103	100 nF 20% 250V	C201	4130176	33 nF 20% 63V
C3	4130280	220 nF 20% 100V	C202	4200423	2.2 μF 20% 50V
C4	4130280	220 nF 20% 100V	C203	4000092	180 pF 5% 63V
C5	4130280	220 nF 20% 100V	C204	4010063	4.7 nF 10% 63V
C8	4200431	10 μF 20% 16V	C205	4200478	100 μF 20% 10V
C9	4200431	10 μF 20% 16V	C206	4200478	100 μF 20% 10V
C16	4010063	4.7 nF 10% 63V	C207	4000136	22 pF 5% 63V
C10	4200688	47 μF 20% 50V	C208	4003130	47 pF 2% 63V
C11	4200480	22 μF 20% 10V	C209	4130193	22 nF 20% 63V
C12	4130179	100 nF 20% 63V	C210	4130215	220 nF 20% 63V
C13	4130179	100 nF 20% 63V	C211	4130215	220 nF 20% 63V
C14	4200431	10 μF 20% 16V	C212	4200476	0.47 μF 20% 50V
C15	4200423	4700 μF -10+50% 16V	C213	4200431	10 μF 20% 16V
C20	4010063	4.7 nF 10% 63V			

L200	6850114	Coil 0.5 μH
------	---------	-------------

RL6	7600046	Relay 6V
-----	---------	----------

F1	6600020	Fuse T2.5-T/250V	F2	6600076	Fuse 0.5A-F
F1(2333)	6600075	Fuse T2.5A-T			

P14	7220431	Plug 9/9 pins	P24	7220195	Plug 2/2 pins
P15	7220429	Plug 7/7 pins		7220580	Plug 2 pins
P18	7220160	Plug 5/4 pins		7220510	Jack plug
P23	7220185	Plug 3/3 pins			

7200223	Fuse holder
---------	-------------

R9	5020455	470 Ω 5% 1W	R223	5020019	36.5 kΩ 1% 1/4W
R10	5020455	470 Ω 5% 1W			

C1	4130193	22 nF 20% 63V	C11	4200476	0.47 μF 20% 50V
C2	4010063	4.7 nF 10% 63V	C12	4010006	2.2 nF 10% 63V
C3	4130226	220 nF 10% 63V	C13	4010006	2.2 nF 10% 63V
C6	4200688	47 μF 20% 50V	C200	4200423	2.2 μF 20% 50V
C7	4130224	100 nF 10% 63V	C201	4000094	150 pF 5% 63V
C8	4130224	100 nF 10% 63V	C202	4010065	2.7 nF 10% 63V
C9	4200431	10 μF 20% 16V	C203	4000094	150 pF 5% 63V
C10	4200431	10 μF 20% 16V	C204	4010167	2.7 nF 10% 100V

PCB 2, 8002679,
8002914 Type 2333
Output and Power supply.

For Service Manuals Contact
MAURITRON TECHNICAL SERVICES
8 Cherry Tree Rd, Chinnor
Oxon OX9 4QY
Tel:- 01844-351694 Fax:- 01844-352554
Email:- enquiries@mauritron.co.uk

PCB 3, 8002675,
Pre-amplifier.

C205	4130213	10 nF 10% 63V	C223	4130176	33 nF 20% 63V
C206	4200426	1 μ F 20% 50V	C224	4200426	1 μ F 20% 50V
C207	4200426	1 μ F 20% 50V	C225	4003128	100 pF 5% 63V
C208	4200426	1 μ F 20% 50V	C226	4200426	1 μ F 20% 50V
C209	4000094	150 pF 5% 63V	C227	4010061	2.2 nF 10% 63V
C210	4003128	100 pF 5% 63V	C228	4200431	10 μ F 10% 63V
C211	4000094	150 pF 5% 63V	C229	4130244	22 nF 10% 63V
C212	4010024	470 pF 10% 63V	C230	4130224	100 nF 10% 63V
C213	4010111	3.3 nF 10% 63V	C231	4130213	10 nF 10% 63V
C217	4000023	150 pF 5% 63V	C232	4130224	100 nF 10% 63V
C218	4200426	1 μ F 20% 50V	C233	4200426	1 μ F 20% 50V
C219	4000173	47 pF 5% 63V	C235	4130214	10 nF 20% 63V
C220	4000094	150 pF 5% 63V	C236	4130214	10 nF 20% 63V
C221	4200426	1 μ F 20% 50V	C237	4130214	10 nF 20% 63V
C222	4200431	10 μ F 20% 16V	C238	4010027	1 nF 10% 63V

L1 8020621 Coil 100 μ H

RL1 7600073 Relay 6V

P5	7220425	Plug 3/3 pins	P9	7220585	Plug 5/5 pins
P6	7220428	Plug 6/6 pins	P10	7220425	Plug 3/3 pins
P7	7220428	Plug 6/6 pins	P21	7220206	Plug 5/4 pins
P8	7220429	Plug 7/7 pins	P22	7220313	Plug 3/3 pins

PCB 4. 8022607,
Microcomputer.

C1	4200364	47 μ F -10+50% 10V	C28	4010035	1 nF 10% 63V
C2	4010041	10 nF -20+80% 40V	C29	4010035	1 nF 10% 63V
C3	4130228	470 nF 20% 63V	C30	4000167	18 pF 5% 63V
C4	4130225	150 nF 10% 63V	C31	4000167	18 pF 5% 63V
C5	4010035	1 nF 10% 63V	C32	4010041	10 nF -20+80% 40V
C6	4010035	1 nF 10% 63V	C35	4130225	150 nF 10% 63V
C7	4010035	1 nF 10% 63V	C36	4010024	470 pF 10% 63V
C8	4010035	1 nF 10% 63V	C37	4003128	100 pF 5% 63V
C9	4010035	1 nF 10% 63V	C38	4010061	2.2 nF 10% 63V
C10	4200414	33 μ F -10+50% 16V	C39	4130228	470 nF 20% 63V
C12	4010041	10 nF -20+80% 40V	C40	4010024	470 pF 10% 63V
C15	4130225	150 nF 10% 63V	C41	4000173	47 pF 5% 63V
C16	4010035	1 nF 10% 63V	C42	4010024	470 pF 10% 63V
C17	4010035	1 nF 10% 63V	C43	4010301	15 nF 10% 63V
C18	4010035	1 nF 10% 63V	C44	4010024	470 pF 10% 63V
C19	4010035	1 nF 10% 63V	C45	4100173	47 pF 5% 63V
C20	4010035	1 nF 10% 63V	C46	4003128	100 pF 5% 63V
C21	4010035	1 nF 10% 63V	C47	4003128	100 pF 5% 63V
C22	4000173	47 pF 5% 63V	C48	4010024	470 pF 10% 63V
C23	4010035	1 nF 10% 63V	C49	4010041	10 nF -20+80% 40V
C24	4010035	1 nF 10% 63V	C50	4010024	470 pF 10% 63V
C25	4010035	1 nF 10% 63V	C51	4010027	1 nF 10% 63V
C26	4010035	1 nF 10% 63V			

L1	8020342	Coil 10 μ H	L3	8020342	Coil 10 μ H
L2	8020342	Coil 10 μ H			

BP1 8030056 455 kHz \pm 1 kHz

X1	8090056		X2	8030024	455 kHz \pm 1 kHz
----	---------	--	----	---------	---------------------

F1 6604009 Fuse 1 A

P12	7220554	Plug 12/12 pins	P17	7220317	Plug 4/4 pins
P13	7220554	Plug 13/12 pins	P25	7220176	Plug 2/2 pins
P16	7220585	Plug 5/5 pins			

R3	5020565	8.25 k Ω 1% 1/4W	R7	5020539	47.5 k Ω 1% 1/4W
R5	5230012	15 Ω 20% 1.8W			

PCB 6, 8002173,
Fan regulation

PCB 9, 8002268, Display

C1	4010041	10 nF -20+-80% 40V	C5	4130210	47 nF 20% 63V
C2	4130259	220 nF 1% 160V	C6	4200102	470 pF -10+-100% 40V
C3	4130260	47 nF 1% 160V			
C4	4010027	1 nF 10% 63V			Heatzink 3358186
C1	4130179	100 nF 20% 63V	C12	4010027	1 nF 10% 63V
C3	4010024	470 pF 10% 63V	C15	4200380	1 pF -20+-50% 63V
C4	4000173	47 pF 5% 63V	C16	4010088	220 pF 10% 63V
C5	4010024	470 pF 10% 63V	C17	4010024	470 pF 10% 63V
C6	4010024	470 pF 10% 63V	C18	4000199	82 pF 5% 63V
C7	4010041	10 nF -20+-80% 40V	C19	4201035	22 pF -10+-50% 63V
C8	4003128	100 pF 5% 63V	C20	4200342	10 pF -10+-50% 63V
C9	4003128	100 pF 5% 63V	C21	4130179	100 nF 20% 63V
C11	4010027	1 nF 10% 63V			

PCB 12, 8002690 Microcomputer

L1	8020562	Coil 455 kHz	L3	8020621	Coil 100 pF
S1	7400268	Switch 1 pol	S2	7400268	Switch 1 pol
P11	7220548	Plug 12/12 pins			Plug 17 pins 7220577
R37	5011378	0.82 Ω 5% 1/4W	R58	5020288	1 MΩ 1% 1/4W
R39	5011378	0.82 Ω 5% 1/4W	R117	5370074	10 kΩ 20% 0.1W
R48	5011378	0.82 Ω 5% 1/4W			
C1	4003128	100 pF 5% 63V	C20	4000136	22 pF 5% 63V
C2	4130228	470 nF 20% 63V	C21	4000136	22 pF 5% 63V
C3	4010103	2.2 nF 10% 63V	C22	4010041	10 nF -20+-80% 40V
C4	4010024	470 pF 10% 63V	C27	4010041	10 nF -20+-80% 40V
C5	4200634	47 pF -10+-50% 10V	C28	4010041	10 nF -20+-80% 40V
C6	4000057	47 pF 5% 63V	C29	4010041	10 nF -20+-80% 40V
C7	4010024	470 pF 10% 63V	C30	4010041	10 nF -20+-80% 40V
C8	4130179	100 nF 20% 63V	C31	4010041	10 nF -20+-80% 40V
C9	4010024	470 pF 10% 63V	C32	4130171	330 nF 20% 63V
C10	4000057	47 pF 5% 63V	C33	4200396	220 pF -20+-50% 16V
C11	4010041	10 nF -20+-80% 40V	C34	4200364	47 pF -10+-50% 10V
C13	4130215	220 nF 20% 63V	C35	4130210	47 pF 20% 63V
C14	4200364	47 pF -10+-50% 10V	C36	4130228	470 nF 20% 63V
C18	4010088	220 pF 63V	C37	4130210	47 nF 20% 63V
C19	4010088	220 pF 63V	C38	4010041	10 nF -20+-80% 40V

PCB 13, 8002873 IR - Left

L1	8020342	Coil 10 pF 10%
BP1	8030056	455 kHz ± 1kHz
X1	8090057	Crystal 3.64 MHz
S1	7400268	Switch 1 pol.
C1	4000057	47 pF 5% 63V
C2	4010024	470 pF 10% 63V
C3	4130356	100 nF 20% 63V
L1	8020590	Coil 270 pF 10%
L2	8020590	Coil 270 pF 10%
P5	7220447	Plug 5/5 pins
C1	4000057	47 pF 5% 63V
C2	4010024	470 pF 10% 63V
C3	4130356	100 nF 20% 63V
L1	8020590	Coil 270 pF 10%
L2	8020590	Coil 270 pF 10%
P6	7220447	Plug 5/5 pins

PCB 14, 8002874 IR - Right

L1	8020590	Coil 270 pF 10%
L2	8020590	Coil 270 pF 10%
P5	7220447	Plug 5/5 pins
C1	4000057	47 pF 5% 63V
C2	4010024	470 pF 10% 63V
C3	4130356	100 nF 20% 63V
L1	8020590	Coil 270 pF 10%
L2	8020590	Coil 270 pF 10%
P6	7220447	Plug 5/5 pins

PCB 15, 8002694 Display
PCB 20, 8002839 IR - Sensor

P1	7220581	Plug 7/7 pins	P2	7220587	Plug 7/7 pins
C1	4200522	470 pF -20+-50% 16V	C3	4010024	470 pF 10% 63V
C2	4130224	100 nF 10% 63V	C4	4010024	470 pF 10% 63V
L1	8020562	Coil MF 455 kHz			Socket 8/8 pin 7210290
L2	8020342	Coil 10 pF			
C30	4010166	100 nF -20+-50%	C34	4000321	220 pF 5% 50V
C31	4200635	4.7 pF 20% 16V	C35	4200664	470 pF 20% 63V
C32	4000229	150 pF 5% 50V	C36	4000321	220 pF 5% 50V
C33	4000229	150 pF 5% 50V			
X30	8030024	455 kHz ± 1kHz			

Standard resistors:

Resistors SMD 5% 1/8 W

X1	X10	X100	X1K	X10K	X100K	X1M	X10M
1.0	5011285	5011271	5011197	5011272	5011207	5011207	
1.2	5011286	5011298	5011273	5011310	5011195	5011195	
1.5	5011283	5011203	5011206	5011189	5011198	5011198	
1.8	5011287	5011300	5011286	5011311	5011196		
2.2	5011282	5011192	5011194	5011307	5011208		
2.7	5011283	5011275	5011301	5011183	5011271	5011316	
3.3	5011289	5011202	5011188	5011184	5011313	5011317	
3.9	5011290	5011288	5011202	5011308	5011314	5011318	
4.7	5011291	5011191	5011303	5011193	5011284	5011206	
5.6	5011292	5011276	5011304	5011309	5011199	5011288	
6.8	5011293	5011190	5011305	5011048	5011200	5011319	
8.2	5011294	5011185	5011187	5011285	5011315	5011201	

Resistors 5% 1/2 W

X1	X10	X100	X1K	X10K	X100K	X1M	X10M
1.0	5011000	5011013	5011028	5011044	5010313	5011069	5011083
1.2	5011406	5011001	5011014	5011030	5011045	5011058	5010421
1.5	5010727	5011002	5011015	5011031	5011046	5011059	5011071
1.8	5010857	5010787	5011019	5011033	5011047	5011072	
2.2	5011335	5010708	5010818	5011034	5011048	5011061	5011074
2.7	5011083	5011018	5011035	5011049	5011062	5011075	
3.3	5010255	5011007	5011019	5011037	5011063	5010381	
3.9	5010782	5011021	5010700	5011051	5011065	5011078	
4.7	5010765	5011009	5011022	5010035	5011036	5011065	5011079
5.6	5011010	5011023	5011041	5011041	5011066	5011079	
6.8	5011011	5011024	5011042	5010810	5011067	5011080	
8.2	5011012	5011025	5011043	5010038	5011068	5011081	

Resistors 5% 1/4 W

X1	X10	X100	X1K	X10K	X100K	X1M	X10M
1.0	5010592	5010506	5010065	5010040	5010059	5010049	5010638
1.2	5010595	5010128	5010153	5010046	5010047	5010065	
1.5	5010488	5010057	5010247	5010053	5010063	5010093	
1.8	5010822	5010362	5010066	5010135	5010072	5010791	
2.2	5010682	5010448	5010092	5010064	5010079	5010120	5010245
2.7	5010925	5010403	5010000	5010298	5010141	5010083	5010431
3.3	5010253	5010044	5010076	5010075	5010117	5010948	
3.9	5010622	5010070	5010069	5010060	5010073	5010714	
4.7	5010888	5010411	5010058	5010048	5010045	5010077	
5.6	5010706	5010151	5010067	5010041	5010061	5010071	5010658
6.8	5010904	5010039	5010144	5010052	5010062	5010074	
8.2	5010880	5010056	5010068	5010154	5010091	5010505	

Resistors 5% 1/8 W

X1	X10	X100	X1K	X10K	X100K	X1M	X10M
1.0	5011357	5010816	5011442	5010935	5011440	5011174	
1.2	5011351	5011351	5011442	5011338	5011338	5011175	
1.5	5011443	5011178	5011364	5011364	5011398	5011176	
1.8	5011350	5011361	5011344	5011344	5011369	5011370	
2.2	5011032	5011376	5010886	5011353	5010833	5011369	
2.7	5011355	5011355	5011366	5011366	5011370	5011370	
3.3	5011337	5010827	5011346	5011346	5011371	5011177	
3.9	5011337	5011157	5011346	5011346	5011372	5011177	
4.7	5011363	5011038	5011441	5011363	5010937	5011372	
5.6	5011358	5010885	5011166	5011166	5011166	5011166	
6.8	5011356	5011356	5010839	5011367	5011367	5011367	
8.2	5011354	5011354	5011339	5011368	5011368	5011373	

For Service Manuals Contact
MAURITRON TECHNICAL SERVICES
8 Cherry Tree Rd, Chinnor
Oxon OX9 4QY
Tel: 01844-351694 Fax: 01844-352554
Email: enquiries@mauritron.co.uk

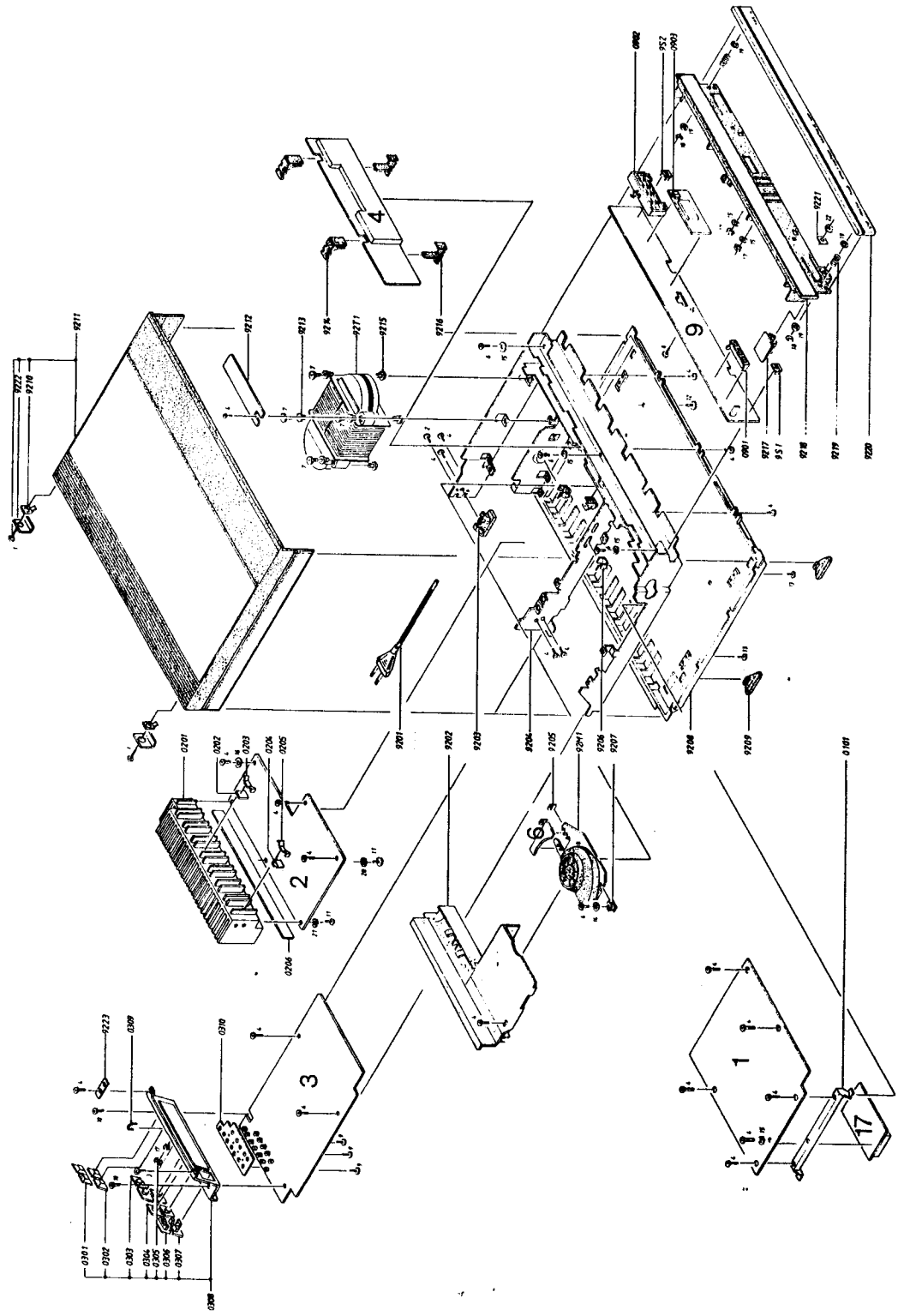

MEKANISK STYKLISTE MECHANICAL PARTS LIST

01Modul	8002671	PCB HF, type 2331/32	PCB RF, type 2331/32
	8002818	PCB HF, type 2333/35	PCB RF, type 2333/34/35
	8002908	PCB HF, type 2334	PCB HF, type 2334
0101	2566047	Skinne	Rail
02Modul	8002679	PCB Udgang & Netdel	PCB Output and power supply
0201	2568679	Køleprofil	Heatsink
0202	6141103	Print	PC-Board
0203	2819175	Fjeder	Spring
0204	2622231	Glimmerskive	Mica sheet
0205	2819175	Fjeder	Spring
0206	2560123	Skinne	Rail
03Modul	8002675	PCB Indgang	PCB Preamplifier
0301	7210520	Stikdåse højttaler 3 pol	Socket loudspeaker 3 pole
0302	7210521	Stikdåse højttaler 4 pol	Socket loudspeaker 4 pole
0303	7210519	Stikdåse 6 pol	Socket 6-pole
0304	7210600	Stikdåse 7 pol	Socket 7-pole
0305	2382009	Fingermøtrik	Milled nut
0306	7210558	Stikdåse AM	Socket AM
0307	7210557	Stikdåse FM	Socket FM
0308	8002866	Stikpanel kompl.	Socket panel compl.
0309	2510134	Kortslutningsbøjle	Shortcircuit bracket
0310	3014059	Styr	Guide
04Modul	8002607	PCB Microcomputer	PCB Microcomputer
06Modul	8002173	PCB Motorstyring	PCB Fan regulation
09Modul	8002268	PCB Display	PCB Display
0901	3131252	Hus, display	Housing, display
0902	3131260	Hus, program	Housing, programme
0903	8002683	Print	PC-Board
9S1	7400268	Omskifter 1 pol.	Switch 1-pole
9S2	7400268	Omskifter 1 pol.	Switch 1-pole
17Modul	8002262	PCB Tuner FM	
9201	6271102	Netledning m/eurostik	Mains cable with Euro plug
	6270251	Netledning for type 2333	Mains cable for type 2333
	6271119	Netledning for type 2334	Mains cable for type 2334
	6271091	Netledning for type 2335	Mains cable for type 2335
9202	3131211	Hus for blæser	Housing for fan
9203	3152367	Ledningsholder	Cable holder
9204	3454373	Ramme	Frame
9205	2938205	Bøsning	Bushing
9206	3152366	Ledningsholder	Cable holder
9207	2938206	Bøsning	Bushing
9208	3454384	Bund	Bottom
9209	3035119	Gummifod	Rubber foot
9210	2391059	Låseplade	Locking plate
9211	3413008	Kabinet - alu	Cabinet - aluminium
9212	8002778	PCB mont. sikring	PCB mount. fuse,
		type 2331/32/35	type 2331/32/35
	8002814	PCB mont. sikring	PCB mount. fuse,
		type 2333/2334	type 2333//2334
9213	2938154	Bøsning	Bushing
9214	3152341	Holder	Holder
9215	2938154	Bøsning	Bushing
9216	3014060	Holder	Holder
9217	8002680	PCB hovedtelefon med stik	PCB Headphones with plugs
9218	3114262	Display - hus	Display - housing
9219	2812095	Fjeder	Spring
9220	2568920	Skinne	Rail
9221	2640050	Låseplade	Locking plate
9222	3034073	Låseplade	Locking plate
9223	3170152	Isolationsstykke	Insulation piece

For Service Manuals Contact
MAURITRON TECHNICAL SERVICES
 8 Cherry Tree Rd, Chinnor
 Oxon OX9 4QY
 Tel: 01844-351694 Fax: 01844-352554
 Email: enquiries@mauratron.co.uk

Master Control Panel,
Type 2048
Master Control Panel,
Type 2048

92T1	8013354	Transformator type 2331	Transformer type 2331
	8013362	Transformator type 2332	Transformer type 2332
	8013363	Transformator type 2333	Transformer type 2333
	8013364	Transformator type 2334	Transformer type 2334
	8013365	Transformator type 2335	Transformer type 2335

92M1	8410011	Blæser kompl.	Fan complete
------	---------	---------------	--------------

	6275615	Hoved lednings bundt	Main cable bundel
--	---------	----------------------	-------------------

11Modul	8002685	PCB Betjening	PCB Keyboard
1101	7500211	Kontaktfjeder	Contact spring
1102	7500211	Kontaktfjeder	Contact spring

12Modul	8002690	PCB Microcomputer	PCB Microcomputer
---------	---------	-------------------	-------------------

13Modul	8002873	PCB IR - venstre	PCB IR - left
---------	---------	------------------	---------------

14Modul	8002874	PCB IR - højre	PCB IR - right
---------	---------	----------------	----------------

15Modul	8002694	PCB, Display	PCB, display
---------	---------	--------------	--------------

9501	2804056	Skive, volume	Washer, volume
9502	2776036	Knapp, status	Button, status
9503	8002872	Print m. switch	PC-Board with switch
	7400336	Switch	Switch
9504	2804053	Hjul	Wheel
9505	3322103	IR - rude	IR - window
9506	2622405	Pakning	Packing
9507	2900013	Kugleleje	Ball bearing
9508	3168707	Panel kompl.	Panel compl.
9509	2776081	Knapsæt	Set of buttons
9510	2854125	Arm	Arm
9511	2570050	Afstandsstykke	Spacer
9512	2952015	Holder	Holder
9513	3454326	Bund	Bottom
9514	2818075	Fjeder	Spring
9515	2805000	Skærm	Screen
9516	3010007	Gummifod	Rubber foot
9517	3164460	Batteridæksel	Battery cover
9518	2576050	Afstandsstykke	Spacer
9519	2568923	Låg	Cover
9520	2805000	Skærm	Screen
9521	2818074	Fjeder	Spring
9522	3131253	Hus, display	Housing, display
9523	3131254	Hus, program	Housing, programme
9524	3131255	Hus, volume	Housing, volume
9525	6200062	Båndkabel	Ribbon cable
9526	6200133	Båndkabel	Ribbon cable
9527	6200128	Båndkabel	Ribbon cable
	8700015	Batteri	Battery

95S1	7400356	Switch	Switch
------	---------	--------	--------

For Service Manuals Contact
MAURITRON TECHNICAL SERVICES
8 Cherry Tree Rd, Chinnor
Oxon OX9 4QY
Tel: 01844-351694 Fax: 01844-352554
Email: enquiries@mauritron.co.uk

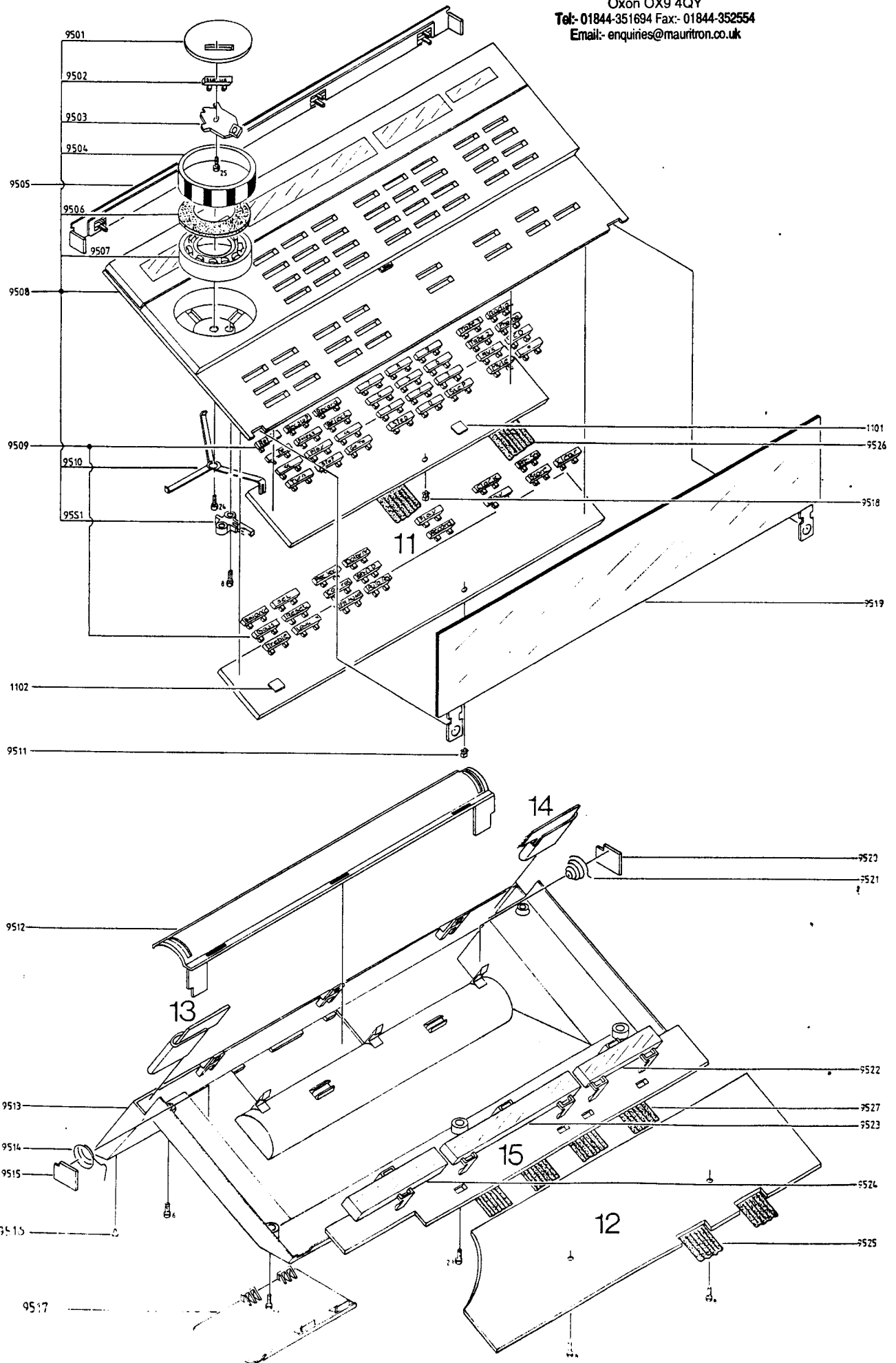

Audio Terminal Type 2049

For Service Manuals Contact
MAURITRON TECHNICAL SERVICES
 8 Cherry Tree Rd, Chinnor
 Oxon OX9 4QY
 Tel: 01844-351694 Fax: 01844-352554
 Email: enquiries@mauritron.co.uk

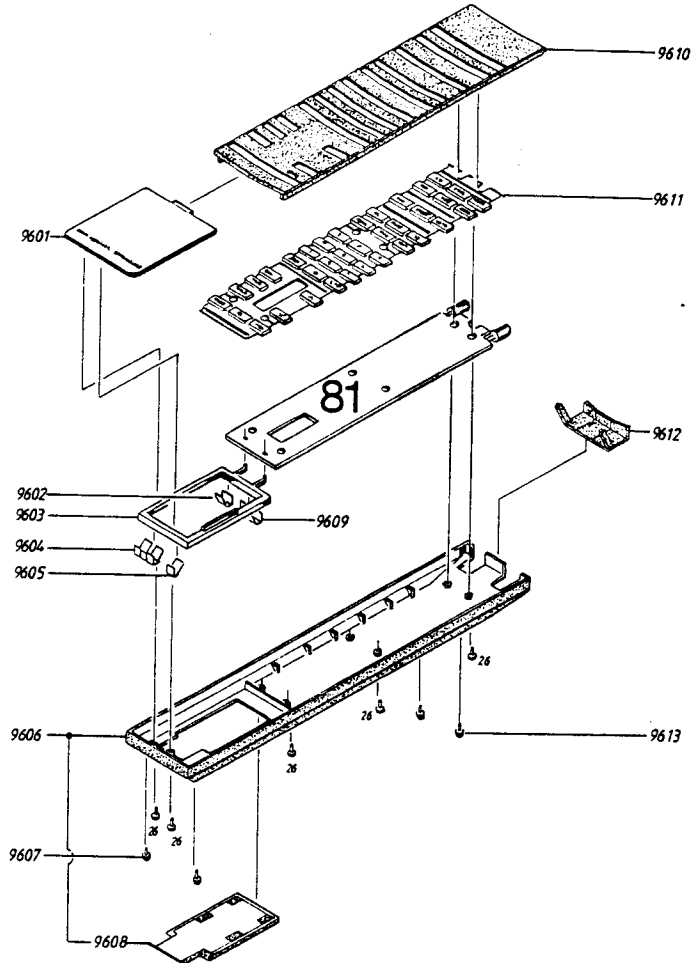

81Modul 8002806 PCB Audio terminal

PCB Audio terminal

9601	3164609	Dæksel	Cover
9602	2819229	Fjeder	Spring
9603	3015131	Styr for batteri	Guide for battery
9604	2819204	Fjeder	Spring
9605	2819205	Fjeder	Spring
9606	3131265	Bund	Bottom
9607	3341020	Glidesko	Plastic foot
9608	3164552	Dæksel	Cover
9609	2819228	Fjeder	Spring
9610	3131268	Top	Top
9611	2776038	Knapsæt	Set of buttons
9612	3375047	Linse	Lenze
9613	3341020	Glidesko	Plastic foot
	8700017	Batteri	Battery

IR - Sensor
Type 2001

4-6

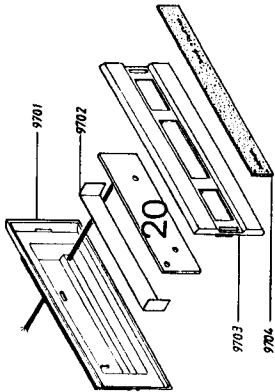

20 Modul 8002839 PCB IR-Sensor
312118 Ledingholder

9701	3452535	Bagpart	Rear part
9702	3302431	Skærm	Screen
9703	3114263	Skjulte	Locking plate
9704	2568975	Tangent	Key
	3390286	Tilbehør 1	Accessories 1
	3390282	Tilbehør 2	Accessories 2
	3502582	Installations vejl.	Mounting instructions
	3397571	Skumemballage f. Beomaster	Foam packing set for Beomaster
	3917049	Indlæg f. Beomaster	Insert for Beomaster
	3391251	Yderkasse for Beomaster	Outer carton for Beomaster
	3397495	Skumemballage sæt f. MCP	Foam packing set for MCP
	3391687	Indlæg f. MCP	Insert for MCP
	3391273	Yderkasse f. MCP	Outer carton for MCP
	3395003	Skumemballage f. Terminal	Foam packing for Terminal
	3395001	Yderkasse f. Terminal	Outer carton for Terminal
	3391840	Yderkasse f. IR-Sensor	Outer carton for IR Sensor
	6270349	Adaptor Sensor/Remote Main switch	Adaptor Sensor/Remote Main switch

Ikke viste dele:
Parts not shown:

Skruer, skiver m.m.
Screws, washers etc.

1	2043016	Skrue AM 4x10 DIN 7985	Screw AM 4x10 DIN 7985
2	2015913	Skrue M 3,5x9,5 DIN 7981	Screw M 3,5x9,5 DIN 7981
3	2039019	Skrue AM 3x5 DIN 965	Screw AM 3x5 DIN 965
4	2039020	Skrue AM 3x5 DIN 7985	Screw AM 3x5 DIN 7985
5	2039030	Skrue AM 3x10 DIN 7985	Screw AM 3x10 DIN 7985
6	2039035	Skrue M 3x8	Screw M 3x8
7	2043003	Skrue AM 4x25 DIN 7985	Screw AM 4x25 DIN 7985
8	2013118	Skrue PT 3x8	Screw PT 3x8
9	2039028	Skrue AM 3x8 DIN 7985	Screw AM 3x8 DIN 7985
10	2039069	Skrue AM 3x8 DIN 7985	Screw AM 3x8 DIN 7985
11	2013069	Skrue U 2,9x7,9 DIN 7981	Screw U 2,9x7,9 DIN 7981
12	2039062	Skrue M 3x5	Screw M 3x5
13	2043020	Skrue AM 4x6 DIN 7985	Screw AM 4x6 DIN 7985
14	2622015	Skive 3,2	Washer 3,2
15	2622041	Skive 3,2 DIN 125	Washer 3,2 DIN 125
16	2625002	Skive 3,2 DIN 6798	Washer 3,2 DIN 6798
17	2380011	Møtrik M3 DIN 934	Nut M3 DIN 934
18	2380001	Skive 2,3 Dm 6799	Washer 2,3 Dm 6799
19	2620020	Skive 3,2	Washer 3,2
20	2622014	Skive 3,2	Washer 3,2
21	2622052	Skive 3,2	Washer 3,2
22	2380145	Møtrik	Nut
23	2029033	Skrue M 3x6	Screw M 3x6
24	2013080	Skrue U 2,9x9,5	Screw U 2,9x9,5
25	2013099	Skrue U 2,9x6,5	Screw U 2,9x6,5
26	2034006	Skrue AM 2x5 DIN 965	Screw AM 2x5 DIN 965

Modulemballage/
Modulpacking

4-6

4-6

Modul no.	Designation	Emb. no.
1	HF	3391792
2	Output and Power supply	3391792
3	Preamplifier	3391792
4	Microcomputer	3391792
9	Display	3391854
11	Keyboard (MCP)	3391792
12	Microcomputer (MCP)	3391576
15	Display (MCP)	3391792

For Service Manuals Contact
MAURITRON TECHNICAL SERVICES
8 Cherry Tree Rd, Chinnor
Oxon OX9 4QY
Tel: 01844-351694 Fax: 01844-352554
Email: enquiries@mauritron.co.uk

ELEKTRISKE JUSTERINGER

Henvisningerne er for højre kanal. (Henvisningerne i parantes er for venstre kanal).
Alle betjeninger gøres på Master Control Panellet.

5V Netdel

Tilslut DC voltmeter til 2P14-5.
Juster til $5.1V \pm 0.1V$ ved at afbryde eller kortslutte 2J38 og 2J43.

Tomgangsstrøm

Tomgangsstrømmen justeres medens modtageren er kold og med neddrejet volumekontrol.
Højtalere må ikke være tilsluttet.
Tilslut DC voltmeter mellem 2TP200 og 2TP201 (2TP400 og 2TP401).
Juster 2R226 (2R426) til 11mV.

Brightness (Display)

Tilslut DC voltmeter over 9R15.
Tryk AUX.
Juster 9R12 til 3.75V.

Strømforsyning (MCP)

Kortslut 12TP3 til stel.
Tilslut et DC voltmeter til kollektor på 12TR37.
Juster 12R117 til 4.75V.

Volume sensor (MCP)

Tilslut DC voltmeter til ben 2 på 12IC2.
Når volume hjulet drejes skal spændingen svinge minimum mellem 2V og 2.8V.
Eventuel justering kan gøres ved at klippe eller lodde 12R23, 12R25 eller 12J57.

ELECTRICAL ADJUSTMENTS

Instructions apply to the right channel. (Instructions given in brackets apply to the left channel). All operations are carried out from the Master Control Panel.

5V Power-supply unit

Connect DC voltmeter to 2P14-5.
Adjust to $5.1V \pm 0.1V$ by disconnecting or short-circuiting 2J38 and 2J43.

No-load current

Adjust the no-load current while the receiver is cold and with the volume control turned down.
Speakers must not be connected.
Connect DC voltmeter between 2TP200 and 2TP201 (2TP400 and 2TP401).
Adjust 2R226 (2R426) to 11mV.

Brightness (Display)

Connect DC voltmeter across 9R15.
Press AUX.
Adjust 9R12 to 3.75V.

Power supply (MCP)

Short-circuit 12TP3 with chassis.
Connect a DC voltmeter to the collector at 12TR37.
Adjust 12R117 to 4.75V.

Volume sensor (MCP)

Connect DC voltmeter to pin 2 at 12IC2.
When the volume wheel is turned, the voltage should oscillate between 2V and 2.8V as a minimum.
Any adjustments which might be necessary may be performed by cutting or soldering 12R23, 12R25 or 12J57.

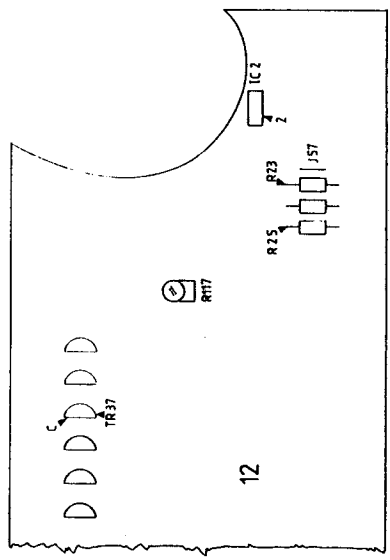
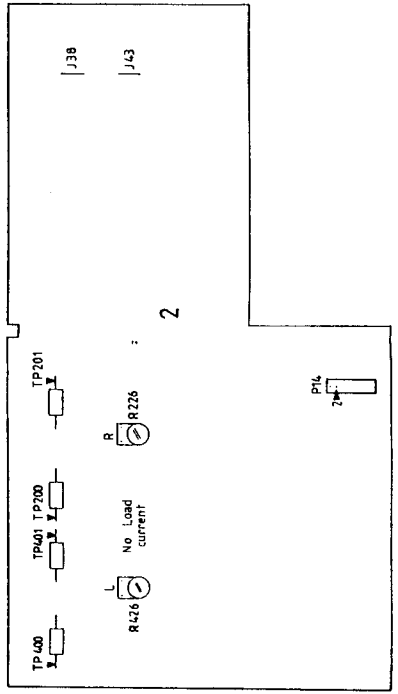
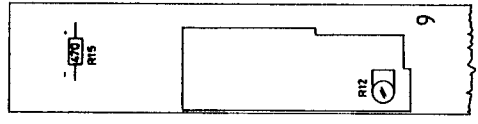
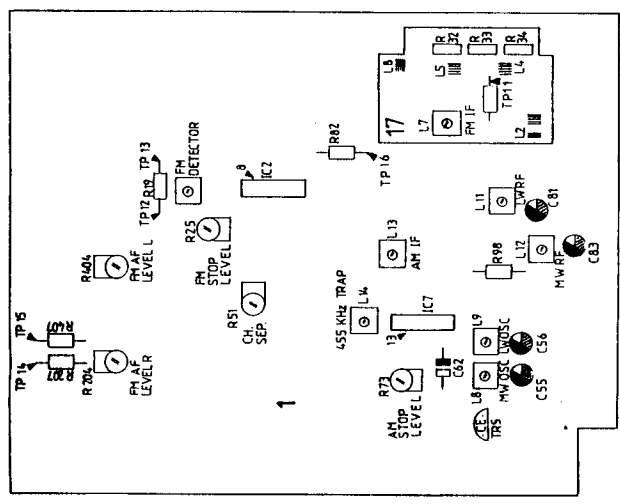

HF JUSTERINGER

Ved visse justeringer skal AFT'en være in-aktiv. Dette ses ved at LOCKED indikatorens skal være slukket (LOCKED off). Ved justeringer uden AFT skal signalgeneratoren først tilsluttes, når modtagerens frekvens er indstillet.

Alle betjeninger gøres på Master Control Panelet.

Udskiftning på FM tuner

Ved udskiftning af FM tuner er det kun nødvendigt at justere MF spolen 17L7.

MF

Tilslut et oscilloskop til 11C2 ben 8.
Tryk RADIO.
Tryk TURN til displayet viser 87.5.
Tryk GO TO (LOCKED off).
Tilslut en sweepgenerator til antenneindgangen og indstil den til 87,5MHz.
Juster 17L7 til maksimum og symmetrisk MF kurve.

TUNER JUSTERINGER (KUN HVIS TUNEREN ER MISJUSTERET)

Oscillator

Der skal ikke tilføjes signal.
Tilslut DC voltmeter mellem 17TP11 og ben 8 på tuneren.
Tryk RADIO.
Tryk TURN til displayet viser 87,5.
Juster 17L8 til 0V.

HF 87,5 MHz

Tilslut et oscilloskop til 11C2 ben 8.
Tryk RADIO.
Tryk TURN til displayet viser 87,5.
Tryk GO TO (LOCKED off).
Tilslut en sweepgenerator til antenneindgangen og indstil den til 87,5MHz.
Juster 17L2, 17L4, 17L5 og 17L7 til maksimum og symmetrisk MF kurve.

HF 108 MHz

Tryk GO TO.
Tryk 1080.
Når displayet slukker, tryk GO TO (LOCKED off).
Sweepgeneratorens frekvens ændres til 108 MHz.
Juster 17R32, 17R33 og 17R34 til maksimum.

Detektor

Tilslut oscilloskop til 11C2 ben 8.
Tilslut DC voltmeter over 1R19 (1TP12 og 1TP13).
Tryk RADIO.
Tryk TURN til displayet viser 87,5.
Tryk GO TO.
Tryk 940.
Når displayet slukker, tryk GO TO (LOCKED off).

RF ADJUSTMENTS

The AFT needs to be inactive for certain adjustments. This is shown by the LOCKED indicator being off (LOCKED off). When adjustments are made without the AFT, the signal generator should not be connected until the frequency of the receiver has been set.

All operations are carried out from the Master Control Panel.

Replacement of FM tuner

When replacing an FM tuner, it is only necessary to adjust the IF coil 17L7.

IF

Connect an oscilloscope to 11C2 pin 8.
Press RADIO.
Press TURN until the display shows 87.5.
Press GO TO (LOCKED off).
Connect a sweep generator to the aerial input and adjust it to 87.5MHz.
Adjust 17L7 to maximum and symmetrical IF curve.

TUNER ADJUSTMENT (ONLY IF TUNER IS MALADJUSTED)

Oscillator

Do not input a signal.
Connect DC voltmeter between 17TP11 and the tuner's pin 8.
Press RADIO.
Press TURN until the display shows 87.5.
Adjust 17L8 to 0V.

RF 87.5 MHz

Connect an oscilloscope to 11C2 pin 8.
Press RADIO.
Press TURN until the display shows 87.5.
Press GO TO (LOCKED off).
Connect a sweep generator to the aerial input and adjust it to 87.5MHz.
Adjust 17L2, 17L4, 17L5 and 17L7 to maximum and symmetrical IF curve.

RF 108 MHz

Press GO TO.
Press 1080.
When the display goes off, press GO TO (LOCKED off).
Change sweep generator frequency to 108MHz.
Adjust 17R32, 17R33 and 17R34 to maximum.

Detector

Connect oscilloscope to 11C2 pin 8.
Connect DC voltmeter across 1R19 (1TP12 and 1TP13).
Press RADIO.
Press TURN until the display shows 87.5.
Press GO TO.
Press 940.
When the display goes off, press GO TO (LOCKED off).

Tilslut en målesender til antenneindgangen og indstil den til 94 MHz.

Finindstil målesenderens frekvens til minimum 2. harmonisk forvrængning af signalet, som vist på kurven.

Connect a signal generator to the aerial input and adjust it to 94MHz.

Fine-tune the signal generator to at least second harmonic distortion of the signal as indicated on the curve.

For Service Manuals Contact
MAURITRON TECHNICAL SERVICES
8 Cherry Tree Rd, Chinnor
Oxon OX9 4QY
Tel: 01844-351694 Fax: 01844-352554
Email: enquiries@mauriton.co.uk

RIGTIG



CORRECT

FORKERT



INCORRECT

Juster 1L2 så tæt mod 0V DC som muligt.
NB! Spændingen over 1R19 vil hele tiden variere p.g.a. korrektionspulser fra mikrocomputeren.

Efter detektor justering indstil FM DISPLAY
INDIKERING se afsnit 8.

FM LF output

Tilslut en målesender til antenneindgangen og indstil den til mono, 94MHz, 1mV EMF, $\Delta \pm 75$ kHz.

Tilslut LF voltmeter til 1TP14 (1TP15).

Tryk RADIO.

Tryk TURN til displayet viser 87,5.

Tryk GO TO.

Tryk 940.

Juster 1R204 (1R404) til 1V RMS.

(Type 2333 justeres til 700mV RMS).

Kanalseparation

Tilslut en stereokoder (Encoder) til antenneindgangen og indstil den til 94 MHz og umoduleret signal i den ene kanal.

Tilslut LF voltmeter til 1TP14 eller 1TP15 (den umodulerede kanal).

Tryk RADIO.

Tryk TURN til displayet vises 87,5.

Tryk GO TO.

Tryk 940.

Juster 1R51 til minimum signal i den umodulerede kanal.

Tilslut LF voltmeter til den anden kanal, og indstil stereokoderen til umoduleret signal i den samme kanal.

Kontroller, juster til symmetrisk kanalseparation.

FM stop niveau

Tilslut en målesender til antenneindgangen, og indstil den til 94MHz, 20 μ V EMF, $\Delta \pm 75$ kHz.

Tryk RADIO.

Tryk TURN til displayet visere 87,5.

Tryk GO TO.

Tryk 940.

Drej 1R25 mod uret til stop.

Drej 1R25 med uret til LOCKED indikatoren netop tænder.

Adjust 1L2 as close to 0V DC as possible.

NOTE! The voltage across 1R19 will vary continuously because of correction pulses from the micro-computer.

After adjustment of the detector, adjust the FM DISPLAY INDICATION, see section 8.

FM AF output

Connect a signal generator to the aerial input and adjust it to mono, 94MHz, 1mV EMF, $\Delta \pm 75$ kHz.

Connect AF voltmeter to 1TP14 (1TP15).

Press RADIO.

Press TURN until the display shows 87.5.

Press GO TO.

Press 940.

Adjust 1R204 (1R404) to 1V R.M.S.(Adjust type 2333 to 700mV R.M.S.)

Channel separation

Connect a stereo encoder to the aerial input and adjust it to 94MHz and unmodulated signal in one channel.

Connect AF voltmeter to 1TP14 or 1TP15 (the unmodulated channel).

Press RADIO.

Press TURN until the display shows 87.5.

Press GO TO.

Press 940.

Adjust 1R51 to minimum signal in the unmodulated channel.

Connect AF voltmeter to the other channel, and adjust the stereo encoder to unmodulated signal in the same channel.

Check, adjust to symmetrical channel separation.

FM stop level

Connect a signal generator to the aerial input, and adjust it to 94MHz, 20 μ V EMF, $\Delta \pm 75$ kHz.

Press RADIO.

Press TURN until the display shows 87.5.

Press GO TO.

Press 940.

Turn 1R25 anticlockwise to stop.

Turn 1R25 clockwise until the LOCKED indicator just goes on.

AM

For at undgå indvirkning fra ACC'en, anbefales det at kortslutte 1C62.

LW oscillator

Der skal ikke tilføres signal.
Tilslut DC voltmeter til 1TP16.
Tryk RADIO.
Tryk TURN til frekvensdisplayet viser 150.
Juster 1L9 til $2V \pm 0,25V$.
Tryk GO TO.
Tryk 350.
Juster 1C56 til $25V \pm 0,5V$
Gentag evt. proceduren.

MW oscillator

Der skal ikke tilføres signal.
Tilslut DC voltmeter til 1TP16.
Tryk RADIO.
Tryk TURN til frekvensdisplayet viser 150.
Tryk GO TO.
Tryk 520.
Juster 1L8 til $2V \pm 0,25V$.
Tryk GO TO.
Tryk 1610.
Juster 1C55 til $25V \pm 0,5V$.
Gentag evt. proceduren.

AM MF

Tilslut en sweepgenerator til antenneindgangen, og indstil den til centerfrekvens 455 kHz Δ 10 kHz.
Tilslut et oscilloskop til 1IC7 ben 13.
Tryk RADIO.
Tryk TURN til frekvensdisplayet viser 150.
Tryk GO TO.
Tryk 1500.
Kortslut 1R98.
Juster 1L13 og 1L14 til maksimum og symmetrisk MF kurve.
Kortslutningen over 1R98 fjernes.

ANTENNEKREDSE

MW antennekredsene skal justeres først.

MW

Tilslut en målesender til antenneindgangen, og indstil den til 1500 kHz, 30% modulation.
Tilslut oscilloskop eller LF voltmeter til 1IC7 ben 13.
Tryk RADIO.
Tryk TURN til frekvensdisplayet viser 150.
Tryk GO TO.
Tryk 1500.
Juster 1C83 til maksimum output.
Målesenderens frekvens ændres til 575 kHz.
Tryk GO TO.
Tryk 575 kHz.
Juster 1L12 til maksimum output.
Gentag evt. proceduren.

AM

In order to avoid any kind of influence from the AGC, it is recommended that 1C62 be short-circuited.

LW oscillator

Do not input a signal.
Connect DC voltmeter to 1TP16.
Press RADIO.
Press TURN until the frequency display shows 150.
Adjust 1L9 to $2V \pm 0.25V$.
Press GO TO.
Press 350.
Adjust 1C56 to $25V \pm 0.5V$.
Repeat this procedure if necessary.

MW oscillator

Do not input a signal.
Connect DC voltmeter to 1TP16.
Press RADIO.
Press TURN until the frequency display shows 150.
Press GO TO.
Press 520.
Adjust 1L8 to $2V \pm 0.25V$.
Press GO TO.
Press 1610.
Adjust 1C55 to $25V \pm 0.5V$.
Repeat this procedure if necessary.

AM IF

Connect a sweep generator to the aerial input, and adjust it to centre frequency, 455 kHz Δ 10 kHz.
Connect an oscilloscope to 1IC7 pin 13.
Press RADIO.
Press TURN until the frequency display shows 150.
Press GO TO.
Press 1500.
Short-circuit 1R98.
Adjust 1L13 and 1L14 to maximum and symmetrical IF curve.
Remove the short-circuit across 1R98.

AERIAL CIRCUITS

The MW aerial circuits must be adjusted first

MW

Connect a signal generator to the aerial input, and adjust it to 1500 kHz, 30% modulation.
Connect oscilloscope or AF voltmeter to 1IC7 pin 13.
Press RADIO.
Press TURN until the frequency display shows 150.
Press GO TO.
Press 1500.
Adjust 1C83 to maximum output.
Signal generator frequency is changed to 575 kHz.
Press GO TO.
Press 575 kHz.
Adjust 1L12 to maximum output.
Repeat this procedure if necessary.

LW

Målesenderens frekvens ændres til 330 kHz.
Tryk GO TO.
Tryk 330.
Juster 1C81 til maksimum output.
Målesenderens frekvens ændres til 160 kHz.
Tryk GO TO.
Tryk 160.
Juster 1L11 til maksimum output.
Gentag evt. proceduren.

AM stop niveau

Kortslutninger over 1C62 fjernes.
Tilslut en målesender til antenneindgangen, og indstil den til 1MHz 30% modulation, og 30 μ V.
Tilslut DC voltmeter til kollektor på 1TR5.
Tryk RADIO.
Tryk TURN til frekvensdisplayet viser 150.
Tryk GO TO.
Tryk 1000.
Juster 1R73 til 2,5 V.

LW

The signal generator frequency is changed to 330kHz.
Press GO TO.
Press 330.
Adjust 1C81 to maximum output.
Change the signal generator frequency to 160 kHz.
Press GO TO.
Press 160.
Adjust 1L11 to maximum output.
Repeat this procedure if necessary.

AM stop level

Remove the short-circuit across 1C62.
Connect a signal generator to the aerial input, and adjust it to 1MHz 30% modulation, and 30 μ V.
Connect DC voltmeter to the collector at 1TR5.
Press RADIO.
Press TURN until the frequency display shows 150.
Press GO TO.
Press 1000.
Adjust 1R73 to 2.5V.

For Service Manuals Contact
MAURITRON TECHNICAL SERVICES
8 Cherry Tree Rd, Chinnor
Oxon OX9 4QY
Tel:- 01844-351694 Fax:- 01844-352554
Email:- enquiries@mauritron.co.uk

TECHNICAL SPECIFICATIONS

Power output RMS DIN/IEC	2 x 60 watts/8 ohms
Power output music	2 x 85 watts/8 ohms
Harmonic distortion DIN/IEC	<0.02%
Power output 20-20,000 Hz IHF	2 x 50 watts/8 ohms
Total harmonic distortion IHF	<0.09%
Dynamic headroom	1.5 db/8 ohms
Intermodulation IHF	<0.1%

Response vs frequency:

Phono	20-20,000 Hz \pm 1.5 dB
Tape	20-20,000 Hz \pm 1.5 dB
Wideband damping factor	50

Input sensitivity/impedance:

Phono	0.3 mV/47 kohms
Tape - AUX	30 mV/100 kohms
CD player	20 mV/47 kohms
Line	25 mV/47 kohms

Signal-to-noise ratio:

Phono A-weighted, 1 W IHF	>78 dB
Tape A-weighted, 1 W IHF	>80 dB
Tape A-weighted, 50 W output	>97 dB
Channel separation 10,000 Hz	>60 dB

Output:

Tape	500 mV/1 kohms
Line	500 mV/1 kohms
External power amplifier	1 V/1 kohms
Headphones	Max. 10 V/470 ohms
Bass control at 40 Hz	\pm 10 dB
Treble control at 12,500 Hz	\pm 8 dB
FM range	87.5 - 108 MHz
FM aerial impedance	75 and 240 ohms
Usable sensitivity mono	14 dBf-1.4 μ V/75 ohms
Usable sensitivity stereo	19 dBf-2.5 μ V/75 ohms
50 dB quieting sensitivity mono	19 dBf-2.5 μ V/75 ohms
50 dB quieting sensitivity stereo	40 dBf-28 μ V/75 ohms
Signal-to-noise ratio 65 dBf mono	75 dB
65 dBf stereo	70 dB
Frequency response	20-15,000 Hz \pm 1 db
Distortion at 65 dBf mono	0.16%
Distortion at 65 dBf stereo	0.2%
Intermodulation mono	0.1%
Intermodulation stereo	0.1%
Capture ratio	1.7 dB
Adjacent channel selectivity	10 dB
Alternate channel selectivity	70 dB
Spurious response	100 dB
Image response ratio	80 dB
IF response ratio	120 dB
AM suppression	57 dB
Stereo channel separation	45 dB
Subcarrier product rejection	70 dB

AM tuner section:

LW range	150-350 kHz
MW range	520-1610 kHz
LW sensitivity 20 dB S/N ratio	80 μ V
MW sensitivity 20 dB S/N ratio	60 μ V
Power supply	220 (110-130-240) volts
Power frequency	50-60 Hz
Power consumption	Max. 225 watts
Dimensions W x H x D	42 x 7.5 x 32.5 cm
Weight	8.5 kg

Subject to change without notice

For Service Manuals Contact
MAURITRON TECHNICAL SERVICES
8 Cherry Tree Rd, Chinnor
Oxon OX9 4QY
Tel: 01844-351694 Fax: 01844-352554
Email: enquiries@mauritron.co.uk

ADSKILLELSE Kabinet

DISMANTLING Cabinet

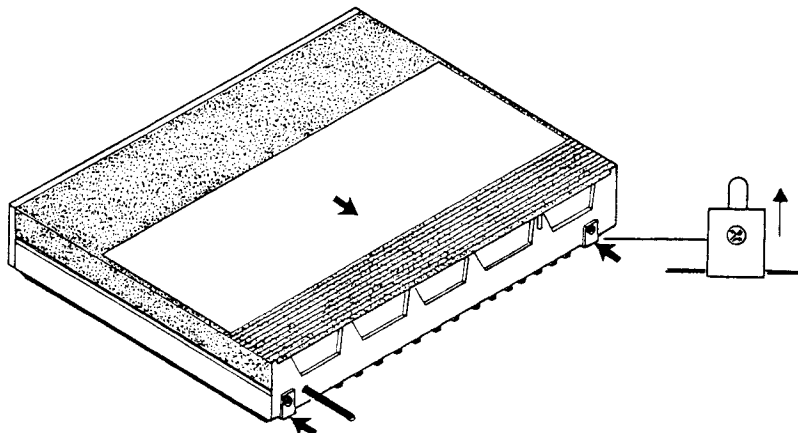

De to viste skruer i bagkanten løsnes og løftes op.

Loosen and lift out the two screws in the rear edge as shown.

Kabinettet presses ca. 1 cm bagud og løftes op.

Press the cabinet approx. 1 cm backwards and lift it out.

PCB 1

PCB 1

For Service Manuals Contact
MAURITRON TECHNICAL SERVICES
8 Cherry Tree Rd, Chinnor
Oxon OX9 4QY
Tel:- 01844-351694 Fax:- 01844-352554
Email:- enquiries@mauritron.co.uk

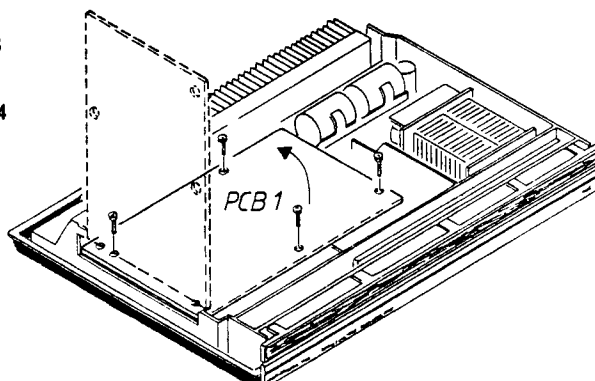

De fire skruer fjernes.

Remove the four screws.

PCB 1 stilles i service position som vist.

Place PCB 1 in service position as shown.

PCB 4

PCB 4

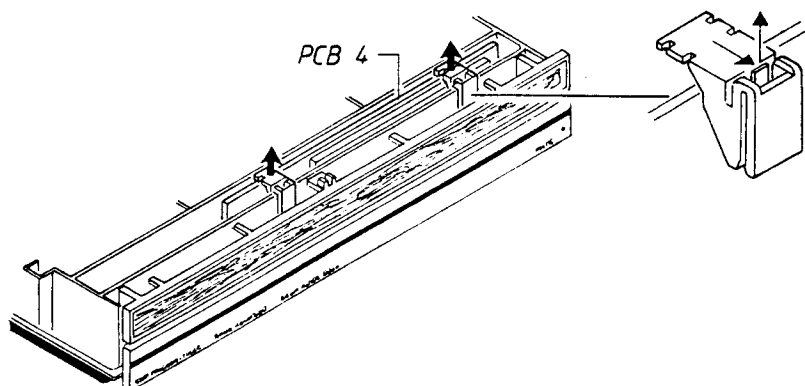

De to viste plastholder løsnes og løftes op.

Loosen and lift out the two plastic holders as shown.

PCB 4 trækkes op.

Pull out PCB 4.

Hus og blæser.

Housing and fan

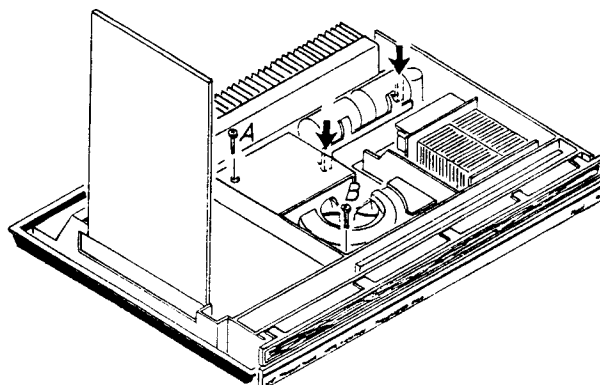

Fjern skruen A

Remove the screw A.

Frigør de to plastappe (ved pilene).

Disengage the two plastic pins (at the arrows).

Huset afmonteres.

Dismantle the housing.

Skruen B fjernes.

Remove the screw B.

Blæseren løftes op.

Lift out the fan.

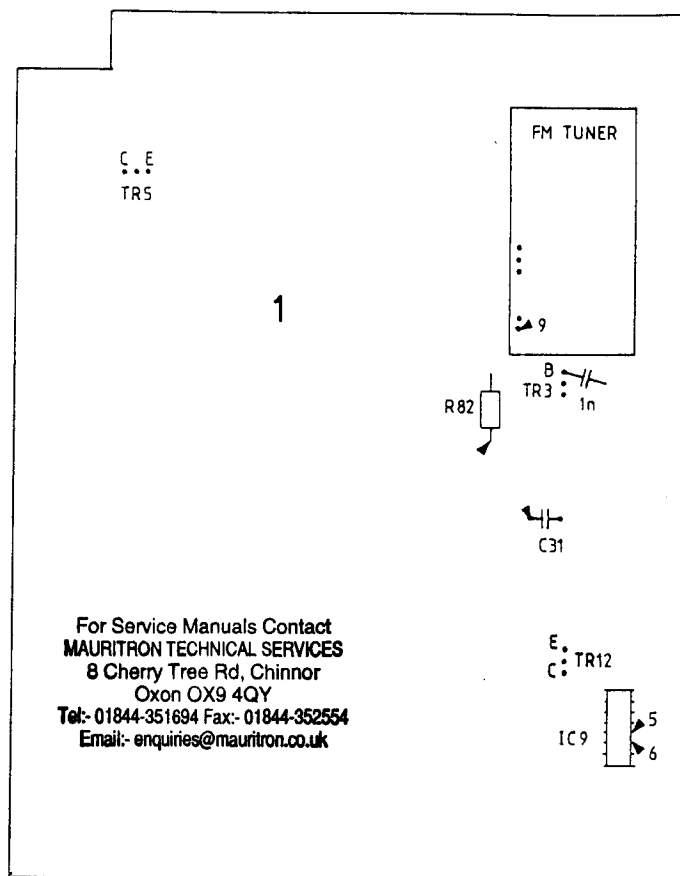

Reparation i tuningssystemet

Ved reparation i tuningssystemet kan det være vanskeligt at lokalisere en fejl.

Følgende servicetips kan benyttes til at »åbne sløjfen« mellem mikrocomputeren og resten af tuningssystemet.

Alle betjeninger gøres på Master Control Panelet.

1. Neddeler af oscillatorfrekvens:

Kortslut kollektor og emitter på 1TR5. Ben 9 på tunerens suges fri for tin, så der ikke er forbindelse til loddeøen.

Tilslut en målesender til basis på 1TR3 via en 1nF kondensator.

Indstil målesenderen til FM, og en frekvens på f.eks. 100,7 MHz, output større end 15mV.

Tryk RADIO.

Tryk TURN til frekvensdisplayet viser 87,5.

Tryk >>.

MCP'ens frekvensdisplay skal nu vise en frekvens, der er 10,7MHz under målesenderens frekvens, i dette tilfælde 90MHz.

Frekvensdeleren deler med 400.

Kortslutningen fjernes.

Repairs in the tuning system.

When carrying out tuning system repairs, it may be difficult to localize a fault. The following service tips may be used for "opening the loop" between the microcomputer and the rest of the tuning system.

All operations are carried out from the Master Control Panel.

1. Oscillator frequency divider:

Short-circuit collector and emitter at 1TR5. Remove all solder from tuner pin 9 so that there is no connection to the soldering point.

Connect a signal generator to the base of 1TR3 via a 1nF capacitor.

Set the signal generator to FM and a frequency of, for example, 100.7MHz, the output being greater than 15mV.

Press RADIO.

Press TURN until the frequency display shows 87.5.

Press >>.

The MCP frequency display will now show a frequency which is 10.7MHz less than the frequency of the signal generator, i.e., 90MHz in this example.

The frequency divider divides by 400.

Remove the short-circuit.

2. Korrektion af afstemningsspænding:

Ben 9 på tunerens suges fri for tin, så der ikke er forbindelse til loddeøen.

Tilslut en målesender til basis på 1TR3 via en 1nF kondensator.

Indstil målesenderen til FM, 100,7MHz, output større end 15mV.

Tilslut et oscilloskop til 1IC9 ben 5 og ben 6.

Tilslut et DC voltmeter til kollektoren på 1TR12.

Tryk RADIO.

Tryk TURN til frekvensdisplayet viser 87,5.

Tryk GO TO.

Tryk 900.

Når frekvensdisplayet slukkes, tryk GO TO.

Målesenderens frekvens reguleres langsomt op.

Dette opfattes som oscillator drift mod højere frekvens af mikrocomputeren, som så skal sende positive korrektionspulser til 1IC9 ben 5.

Reguleres der ned for målesenderens frekvens, i forhold til 100,7 MHz, skal mikrocomputeren sende positive korrektionspulser til 1IC9 ben 6.

Opregulering af frekvensen skal give faldende spænding på DC voltmeteret.

Nedregulering af frekvensen skal give stigende spænding på DC voltmeteret.

3. FM oscillator og HF:

1R82 løftes (den side af 1R82 som vender mod 1TR12 loddes fra).

En variabel DC strømforsyning tilsluttes med + til den fraloddede side af 1R82, og indstilles til 0V.

Tilslut en målsender til FM antenneindgangen.

Indstil senderen til 88MHz.

Tryk RADIO.

Tryk TURN til frekvensdisplayet viser 87,5.

Tryk GO TO.

Tryk 880.

Når frekvensdisplayet slukker, tryk GO TO.

DC strømforsyningen skrues langsomt op, og når modtageren »fanger« 88MHz skal spændingen være ca. 4V.

Målesenderens frekvens ændres til 107 MHz.

Strømforsyningen skrues op, og når modtageren »fanger« frekvensen skal spændingen være ca. 19V.

4. AM oscillator og HF:

1R82 løftes (den side af 1R82 som vender mod 1TR12 loddes fra).

En variabel DC strømforsyning tilsluttes med + til den fraloddede side af 1R82, og indstilles til 0V.

Tilslut en målesender til AM antenneindgangen.

Indstil senderen til 150kHz.

Tryk RADIO.

Tryk TURN til frekvensdisplayet viser 150.

DC strømforsyningen skrues langsomt op, og når modtageren »fanger« 150 kHz skal spændingen være ca. 2V.

Målesenderens frekvens ændres til 350 kHz.

Strømforsyningen skrues op, og når modtageren »fanger« frekvensen skal spændingen være ca. 25V.

2. Correction of tuning voltage:

Remove all solder from tuner pin 9 so that there is no connection to the soldering point.

Connect a signal generator to the base of 1TR3 via a 1nF capacitor.

Set the signal generator to FM, 100.7MHz, output greater than 15mV.

Connect an oscilloscope to 1IC9 pins 5 and 6.

Connect a DC voltmeter to the collector of 1TR12.

Press RADIO.

Press TURN until the frequency display shows 87.5.

Press GO TO.

Press 900.

When the frequency display goes off, press GO TO.

Increase the signal generator frequency slowly.

The microcomputer understands this as oscillator drift towards higher frequency, and it therefore has to send positive correction pulses to 1IC9 pin 5.

If the signal generator frequency is decreased compared to 100.7MHz, the microcomputer has to send positive correction pulses to 1IC9 pin 6.

A frequency increase should result in decreasing voltage on the DC voltmeter.

A frequency decrease should result in increasing voltage on the DC voltmeter.

3. FM oscillator and RF:

Lift 1R82 (desolder the side of 1R82 facing 1TR12).

Connect a variable DC power supply with + at the desoldered side of 1R82, and adjust to 0V.

Connect a signal generator to the FM aerial input.

Set the generator to 88MHz.

Press RADIO.

Press TURN until the frequency display shows 87.5.

Press GO TO.

Press 880.

When the frequency display goes off, press GO TO.

Turn up the DC power supply slowly, and when the receiver "catches" 88MHz the voltage should be approx. 4V.

The signal generator frequency is changed to 107MHz.

Turn up the power supply, and when the receiver "catches" the frequency the voltage should be approx. 19V.

4. AM oscillator and RF:

Lift 1R82 (desolder the side of 1R82 facing 1TR12).

Connect a variable DC power supply with + at the desoldered side of 1R82, and adjust to 0V.

Connect a signal generator to the AM aerial input.

Set the generator to 150kHz.

Press RADIO.

Press TURN until the frequency display shows 150.

Turn up the DC power supply slowly, and when the receiver "catches" 150kHz the voltage should be approx. 2V.

The signal generator frequency is changed to 350kHz.

Turn up the power supply, and when the receiver "catches" the frequency the voltage should be approx. 25V.

Samme procedure kan benyttes i mellembølgeområdet:

520 kHz spænding ca. 2V.

1610 kHz spænding ca. 25V.

Testpunkter i Master Control Panel (MCP)

MCP'en har 4 testpunkter, som kan anvendes ved service:

»CONTINUE« 12TP1

Hvis 12TP1 kortsluttes kortvarigt til 4,75V vil senderen sende et signal med et puls/pause forhold på 200µs/3,1ms.

Senderen slukkes ved at trykke på en knap.

»DISPLAY ON« 12TP2

»DISPLAY ON« anvendes hvis man ønsker at holde på display billedet.

Tryk på en knap for det ønskede display billede. Når displayet er tændt, kortsluttes 12TP2 til stel og MCP'en vendes væk fra Beomasteren, så MCP'en ikke modtager »stopordre« fra Beomasteren.

Displayet fastholdes til der trykkes på en knap.

»SUPPLY CONSTANT ON« 12TP3

Når 12TP3 kortsluttes til stel, tændes netdelen.

Netdelen slukker igen når kortslutningen fjernes.

»BATTERY SENSOR« 12TP4

Når 12TP4 kortsluttes, afprøves battery sensor funktionen.

Tryk på en knap. Når displayet er tændt, kortsluttes 12TP4 til stel, og displayet skal blinke.

The same procedure may be followed in the medium wave range:

520 kHz voltage approx. 2V.

1610 kHz voltage approx. 25V.

Test points in the Master Control Panel (MCP)

The MCP has four test points which may be used when servicing:

“CONTINUE” 12TP1

If 12TP1 is short-circuited briefly to 4.75V, the transmitter will transmit a signal with a pulse/pause ratio of 200µs/3.1ms.

The transmitter is switched off by pressing a button.

“DISPLAY ON” 12TP2

“DISPLAY ON” is used when it is desirable to hold the display picture.

Press a button for the desired display picture.

When the display is on, short-circuit 12TP2 to chassis, and turn the MCP away from the Beomaster so that the MCP will not receive a “stop order” from the Beomaster.

The display is held until a button is pressed.

“SUPPLY CONSTANT ON” 12TP3

When 12TP3 is short-circuited to chassis, the power-supply unit is switched on. The power-supply unit switches off again when the short-circuit is removed.

“BATTERY SENSOR” 12TP4

When 12TP4 is short-circuited, the battery sensor function is tested.

Press a button. When the display is on, short-circuit 12TP4 to chassis, and the display should flash.

For Service Manuals Contact
MAURITRON TECHNICAL SERVICES
8 Cherry Tree Rd, Chinnor
Oxon OX9 4QY
Tel:- 01844-351694 Fax:- 01844-352554
Email:- enquiries@mauritron.co.uk

TESTFUNKTIONER

Beomasteren kan bringes i forskellige »test-modes«, ved at kortslutte 4TP1 til stel i få sekunder.

Der er mulighed for:

- Kontrol af lysdioder i forpladen
- Test af IRsender
- Test af mikroprocessor
- Test af RAM
- Test af displayindikering på AM og FM.

Resultatet af hver test indikeres i displayet, i form af et tal.

Hver test afsluttes med, at apparatet sættes i stand by.

TEST FUNCTIONS

The Beomaster may be brought into different "test modes" by shortcircuiting 4TP1 with the chassis for a few seconds.

Available modes:

- Checking the LED's in the front panel
- Testing the IR transmitter
- Testing the microprocessor
- Testing the RAM
- Testing the display indication for AM and FM.

The result of each test is given on the display in the form of a number.

Each test is concluded by the unit being put on stand by.

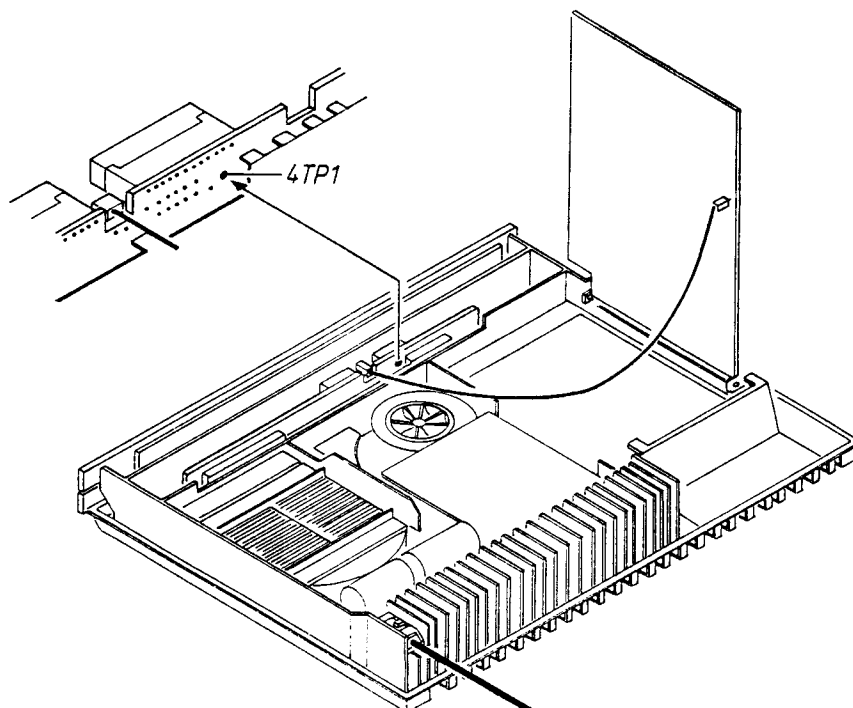

For Service Manuals Contact
MAURITRON TECHNICAL SERVICES
 8 Cherry Tree Rd, Chinnor
 Oxon OX9 4QY
 Tel: 01844-351694 Fax: 01844-352554
 Email: enquiries@mauritron.co.uk

Lysdiodekontrol:

Kortslut kortvarigt 4TP1.
(til stel)

De første 4 sekunder efter kortslutning af 4TP1 vil samtlige lysdioder på frontpladen lyse.

Hvis 4TP1 kortsluttes 2 gange til stel efter hinanden, bringes apparatet straks i »testmode«, og dette indikeres ved, at lysdioderne på forpladen blinker.

Checking LED's:

Short-circuit 4TP1 briefly.
(with chassis).

For the first 4 seconds after the short-circuit of 4TP1, all LED's on the front panel will be on.

If 4TP1 is short-circuited with chassis twice in a row, the unit will immediately be brought into "test mode", indicated by the flashing of the LED's on the front panel.

IRtest:

Tast **RADIO**

Kortslut 4TP1.
(2 gange kortvarigt)

Tast **STEP** på forpladen eller **RADIO** på MCP'en

Display: 1
IR i Beomaster sender

IR test:

Press **RADIO**

Short-circuit 4TP1.
(twice briefly)

Press **STEP** on front plate or **RADIO** on the MCP

Display: 1
IR in Beomaster transmitter

Mikroprocessortest:

Tast RADIO

Kortslut (2 gange kortvarigt) 4TP1.

Tast TAPE

Display: 2 Processor i orden 3 Processor er fejlbehæftet

Microprocessor test:

Press RADIO

Short-circuit (twice briefly) 4TP1

Press TAPE

Display: 2 Processor OK 3 Error in processor

Hvis yderligere kontrol af mikroprocessor er nødvendig, kan følgende gøres:

4P12, 4P13, 4P16, og 4P25 afmonteres, og PCB 4 tages ud af Beomasteren.

Tilslut en strømforsyning med +5V til ben 12 på 4P12, og stel på afskærmningslåget.

PCB 4 skal nu vise følgende spændinger:

	DC	AC
4IC1		
Ben 1-15	ca. 5V	
Ben 16	0V/5V	
Ben 17	ca. 5V	
Ben 18-19		8,8MHz 1-3Vss
Ben 20	0V (stel)	
Ben 21-30	ca. 5V	
Ben 31	0V (stel)	
Ben 40	ca. 5V	
4IC6		
Ben 4		455KHz ca. 3Vss

RAM-test:

Advarsel: RAM nulstilles.

Skal udføres ved udskiftning af PCB04, 04IC2, 04D2, 04R4 eller 3V batteri.

Tast RADIO

Kortslut (2 gange kortvarigt) 4TP1

Tast RESET

Display: 10 RAM-test kører ca. 30 sec.

Display: 11 RAM i orden og nulstillet 12 Der er fejl i RAM

If further microprocessor checks are necessary, the following procedure may be followed:

Dismount 4P12, 4P13, 4P16 and 4P25, and remove PCB 4 from the Beomaster.

Connect a +5V power supply to pin 12 at 4P12 and chassis on the shield lid.

PCB 4 should now display the following voltages:

	DC	AC
4IC1		
Pins 1-15	Approx. 5V	
Pin 16	0V/5V	
Pin 17	Approx. 5V	
Pin 18-19		8.8MHz 1-3Vss
Pin 20	0V (chassis)	
Pins 21-30	Approx. 5V	
Pin 31	0V (chassis)	
Pin 40	Approx. 5V	
4IC6		
Pin 4		455KHz approx. 3Vss

RAM test:

Warning: RAM reset

Should be done when replacing PCB04, 04IC2, 04D2, 04R4 or 3V battery.

Press RADIO

Short-circuit (twice briefly) 4TP1

Press RESET

Display: 10 RAM test runs for approx. 30 sec.

Display: 11 RAM OK and reset 12 Error in RAM

Efter RAM-test skal test af AM- og FM-displayindikering udføres som afslutning.

After the RAM test, testing should be completed with a test of AM and FM display indication.

FM-displayindikering:

Skal udføres ved udskiftning af båndpasfilterne 1BP1, 1BP2 og 1BP3 eller PCB01.

Tast

Tast

Tast
(til MCP indikerer 87,5)

Indstil på en station hvor du kender den nøjagtige frekvens eller

Kontrollere at LOCKED lyser

Kortslut (2 gange kortvarigt) 4TP1

Tast

Indtast den nøjagtige frekvens (eks. 98,5MHz)

Tast
(inden 3 sec.)

Display: 4 Indstillet korrekt 5 Frekvens kan ikke indlæses.

FM display indication:

This test should be carried out in connection with replacement of the band-pass filters 1BP1, 1BP2 and 1BP3, or PCB01.

Press

Press

Press
(until MCP indicates 87.5)

Tune in to a station for which you know the exact frequency or

Check that LOCKED is lit

Short-circuit (twice briefly) 4TP1

Press

Enter the exact frequency (e.g., 98.5MHz)

Press
(within 3 sec.)

Display: 4 Set correctly 5 Frequency input not possible

AM-displayindikering:

Skal gennemføres, hvis det keramiske filter 1BP4 eller PCB01 udskiftes.

Tast

Tast

Tast
(til MCP indikerer 150)

Kortslut (2 gange kortvarigt) 4TP1

Tast

*Indtast frekvens 455 kHz.

Tast
(inden 3 sec.)

AM display indication:

This test should be carried out in connection with replacement of the band-pass filter 1BP4 or PCB01.

Press

Press

Press
(until MCP indicates 150)

Short-circuit (twice briefly) 4TP1

Press

*Enter frequency 455 kHz

Press
(within 3 sec.)

Display: 4 Indstillet korrekt
5 Frekvens kan ikke indlæses.

Display: 4 Set correctly
5 Frequency input not possible

* Ved udskiftning af 1BP4 indtastes den frekvens der står på det nye filter.

* When replacing 1BP4, enter the frequency stated on the new ceramic filter.

Omstilling mellem HF varianter

På diagram A i nederste højre hjørne er vist forskellige koblingsmåder mellem HF varianter. De forskellige koblingsmåder gør, at mikrocomputeren softwaremæssigt kan »se« forskel på varianterne.

Switching between RF variants

Different ways of switching between RF variants are showed in the lower right corner of diagram A. As to the software the different ways of switching enables the microcomputer to "see" the difference between the variants.

Forbindelse A-A: USA og Canada (type 2333).
Søgning på AM i 10 kHz trin, ingen langbølge.

Connection A-A: USA and Canada (type 2333).
Searching on AM in steps of 10 kHz, no long wave.

Forbindelse B-B: Japan (type 2334).
Søgning på AM i 9 kHz trin, ingen langbølge.
FM frekvensområde 76-90 MHz
(kræver speciel FM tuner, bestilingsnr. 8050102)

Connection B-B: Japan (type 2334).
Searching on AM in steps of 9 kHz, no long wave.
FM frequency range 76-90 MHz
(demands a special FM tuner, part no. 8050102).

Forbindelse C-C: Australien (type 2335).
Søgning på AM i 9 kHz trin, ingen langbølge.

Connection C-C: Australia (type 2335).
Searching on AM in steps of 9 kHz, no long wave.

For Service Manuals Contact
MAURITRON TECHNICAL SERVICES
8 Cherry Tree Rd, Chinnor
Oxon OX9 4QY
Tel: 01844-351694 Fax: 01844-352554
Email: enquiries@mauritron.co.uk

Tilslutning af nettransformer/ Connection of Mains Transformer

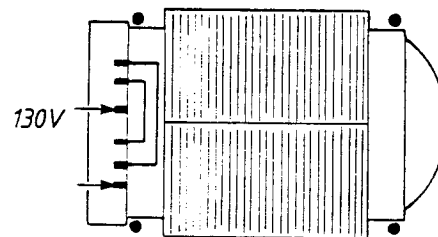
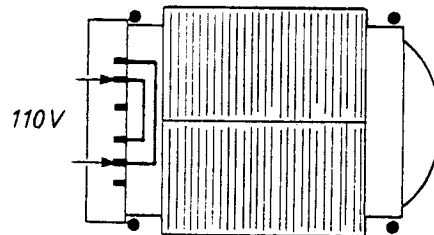
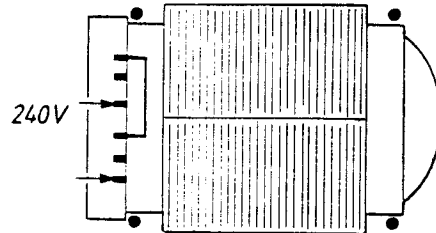
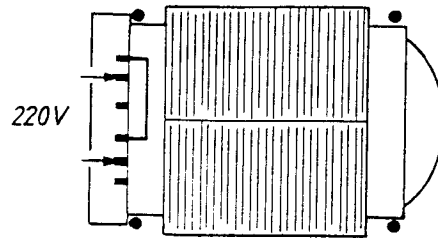

For Service Manuals Contact
MAURITRON TECHNICAL SERVICES
8 Cherry Tree Rd, Chinnor
Oxon OX9 4QY
Tel: 01844-351694 Fax: 01844-352554
Email: enquiries@mauritron.co.uk

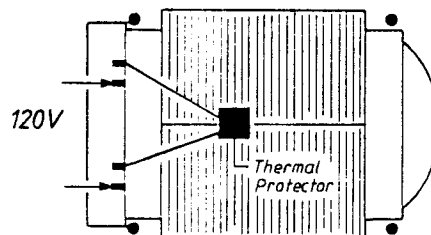

8013363 for type 2333

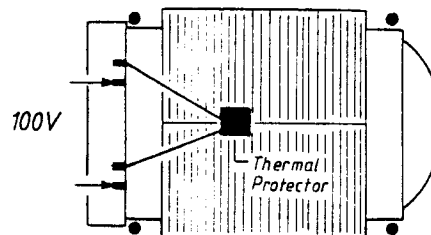

8013364 for type 2334

ISOLATIONSTEST

Ethvert apparat **skal** isolationstestes efter at det har været adskilt. Testen udføres når apparatet igen er helt samlet og klar til udlevering til kunden.

Isolationstest for Beomaster 5500

Isolationstesten udføres på følgende måde:

De to stikben på netstikket kortslyttes og tilsluttes en af terminalerne på isolationstesteren. Den anden terminal fra isolationstesteren tilsluttes stelbenet i hovedtelefonstikdåsen.

OBS!

For at undgå beskadigelser på apparatet er det vigtigt, at **begge** terminaler fra isolationstesteren har virkelig god mekanisk kontakt.

Der drejes nu langsomt med spændingsreguleringen på isolationstesteren indtil en spænding på 1,5 - 2 kV er opnået. Her skal den holdes i 1 sekund, derefter drejes der langsomt ned for spændingen igen.

Der må **ikke** på noget tidspunkt under testen forekomme overslag.

INSULATION TEST

Each set **must** be insulation tested after dismantling. The test is to be performed when the set has been re-assembled and is ready for delivery to the customer.

Insulation test for Beomaster 5500

Make the insulation test as follows: Short-circuit the two plug pins of the mains plug and connect one of the terminals of the insulation tester. Connect the other terminal of the insulation tester to the chassis pin of the headphone socket.

N.B.!

To avoid ruining the set, it is essential that both insulator test terminals are in really good mechanical contact.

Now turn slowly the voltage control of the insulation tester until a voltage of 1.5-2 kV is obtained. Hold it there for 1 second, then turn slowly the voltage down again.

At no point during the testing procedure any flash-overs are permissible.

SLUTAFPRØVNING MCP

Denne afprøvning sikrer at hovedparten af MCPens elektriske funktioner er i orden.

FINAL TESTING

This test ensures that most of the MCP's electrical functions are in order.

TAST/BETJENING	DISPLAY (Kun test displays er nævnt)
Tilslut Beomaster 5500 til lysnet	St.By diode på Beomaster skal lyse
Placer MCPen foran Beomasteren, så de kan kommunikere sammen.	
Tryk RADIO	RADIO og SET CLOCK skal lyse
Tryk STATUS	Volumeskala og frekvensudlæsning i cifferdisplay skal vises. AM eller FM skal lyse.
Drej min.  max.	Ved max. volume skal alle dioder i volumeskala lyse.
Tryk GO TO	MANUAL skal lyse
Tryk TAPE 2	TAPE 2 skal lyse
Tryk CONTROL	CONTROL skal lyse
Afbryd Beomaster 5500 fra lysnettet	
Tryk STATUS	NO CONTACT skal lyse

KEY/OPERATION	DISPLAY (Test displays mentioned only)
Connect Beomaster 5500 to mains	St.BY. LED on the Beomaster should be on
Place the MCP in front of the Beomaster to allow them to communicate	
Press RADIO	RADIO and SET CLOCK should be on
Press STATUS	Volume dial and frequency read-out in digit display should be shown. AM or FM should be on.
Turn min.  max.	When at maximum volume, all LED's in the volume dial should be on
Press GO TO	MANUAL should be on
Press TAPE 2	TAPE 2 should be on
Press CONTROL	CONTROL should be on
Disconnect the Beomaster 5500 from mains	
Press STATUS	NO CONTACT should be on

For Service Manuals Contact
MAURITRON TECHNICAL SERVICES
 8 Cherry Tree Rd, Chinnor
 Oxon OX9 4QY
 Tel: 01844-351694 Fax: 01844-352554
 Email: enquiries@mauritron.co.uk