

BeoSound 9000 MKIII

Type 2571, 2572, 2573, 2574, 2575, 2576, 2577, 2580

Service Manual
English, German, French

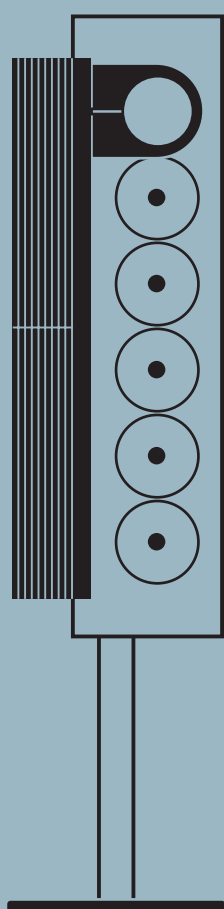

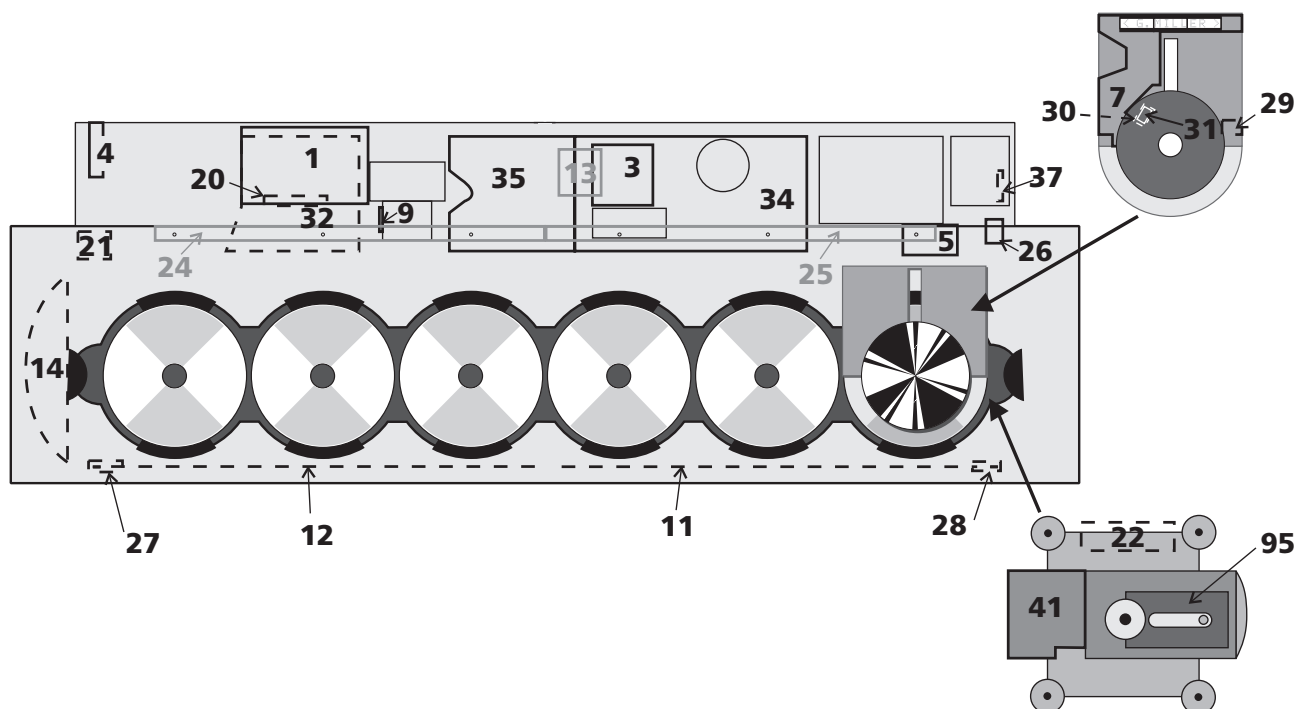

1 FM/AM - RDS.....	diagram A, AA, B, BB	26 End Stop Detector	diagram M
	page 2.11, 12, 13, 14		page 2.28
3 Main Microcomputer	diagram J	27 Safety TX	diagram M
	page 2.24		page 2.28
4 Mains Filter	diagram N	28 Safety RX	diagram M
	page 2.29		page 2.28
5 Mains Relay	diagram N, O	29 Lamp	diagram I
	page 2.29, 30		page 2.23
7 Display	diagram I	30 IR Transmitter, tacho clamber	diagram I
	page 2.23		page 2.23
9 Sledge Position	diagram M	31 IR Reciever, tacho clamber	diagram I
	page 2.28		page 2.23
11 Main Keyboard, right	diagram H	32 Input/output Select, Sound Adj.	diagram E, F, G
	page 2.22		page 2.18, 19, 20
12 Main Keyboard, left	diagram H	34 Power Supply	diagram C, D, G, H, I, J, L, N
	page 2.22		page 2.16, 17, 20, 22, 23, 24, 26, 29
13 Secondary Keyboard	diagram H	35 Motor Control	diagram L, M
	page 2.22		page 2.26, 28
14 IR Receiver	diagram H	37 Lid Motor	diagram M
	page 2.22		page 2.28
20 ML Interface	diagram E	41 CD VAM 1250	
	page 2.18	CD	diagram C
21 Headphone	diagram G		page 2.16
	page 2.20,	Turn Table Motor Control	diagram D
22 Clamber Position	diagram I, L		page 2.17
	page 2.23, 26	95 CD Mechanism, VAM 1250	diagram C, D
24 Light Indication, left	diagram J		page 2.16, 17
	page 2.24		
25 Light Indication, right	diagram J		
	page 2.24		

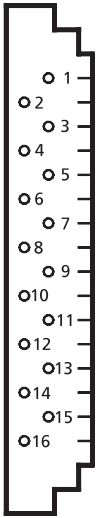
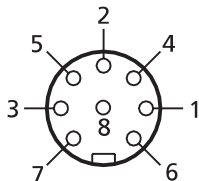
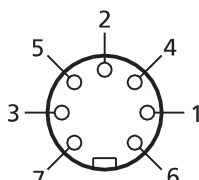
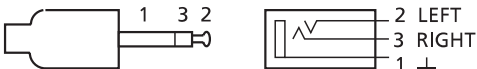

= PCB13, PCB24 and PCB25 placed on the chassis topplate

SPECIFICATION GUIDELINES FOR SERVICE USE	BeoSound 9000 MKIII
With FM and AM range and RDS	Type 2571 (EU), 2572 (GB), 2573 (USA-CDN), 2574 (J), 2575 (AUS), 2576 (TWN), 2577 (KOR), 2580 (LAT)
Operation	Direct keyboard Beo4, BeoLink 1000
Mechanical functions	
Change from playing CD1 to playing CD6 (Lid closed and known CD's)	< 6.5 sec., typical 4 sec.
Position of CD	Typical $\pm 1^\circ$
Tuner	
Number of Programmes	60
Stereo / Mono selection	Automatic / manual
Tuner, FM section	
Range	87.5-108 MHz 76-90 MHz f. type 2564
Aerial impedance	75 ohm
Usable sensitivity mono (30 dB)	Typical 11dBf - 1 μ V
50 dB quieting stereo	≤ 41 dBf
Signal-to-noise at 65 dBf mono	≥ 69 dB
Signal-to-noise at 65 dBf stereo	≥ 64 dB
Frequency response	20-15000Hz
Distortion + noise mono	$\leq 0.6\%$
Distortion + noise stereo	$\leq 0.6\%$
Intermodulation stereo	Typical 0.1%
Stereo channel separation	Typical 30dB
Subcarrier product rejection	≥ 50 dB
Tuner, AM section	
Range	LW 153-279 kHz f. type 2571, 2572, 2575, 2576, 2577 MW 522-1611 kHz f. type 2571, 2572, 2575, 2576, 2577 MW 530-1710 kHz f. type 2573, 2580 MW 522-1629 kHz f. type 2574
Antenna	Loop 18.1 μ H (Special)
LW sensitivity 20 dB S/N ratio	Typical 66dB μ V/m (2mV/m)
MW sensitivity 20 dB S/N ratio	Typical 60dB μ V/m (1mV/m)
Harmonic distortion	Typical 0.4 %
CD Player	
Number of CD's	6
Disc types	12 cm (5"), 8 cm (3") with adaptor
Frequency range	20-20.000 Hz ± 1 dB
Signal-to-noise ratio A-weighted	Typical 101dB
Dynamic range	≥ 98 dB
Harmonic distortion	$\leq 0.1\%$
Channel separation	≥ 50 dB
Channel difference	$\leq \pm 1$ dB
Converter system	Bitstream
Preamplifier section	
Harmonic distortion	$\leq 0.1\%$
Frequency range ± 1 dB	10-20000Hz
Channel separation	≥ 50 dB
Source separation	≥ 80 dB
Signal-to-noise A-weight	≥ 90 dB
Volume control	≥ 90 dB
Bass control	7.0dB ± 2 dB at 100Hz
Treble control	7.0dB ± 2 dB at 10kHz

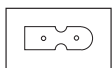
Connections																									
Master Link	 <table border="1"> <tr><td>Pin 1</td><td>Data-, -0.5 V ±0.2 V in relation to Data+</td></tr> <tr><td>Pin 2</td><td>Data+, +0.5 V ±0.2 V in relation to Data-</td></tr> <tr><td>Pin 3</td><td>ML connect > 3 V</td></tr> <tr><td>Pin 4-6</td><td>+supply voltage, +7 V to +15 V (in stand-by +3 V to +15 V)</td></tr> <tr><td>Pin 7-10</td><td>Not used</td></tr> <tr><td>Pin 11</td><td>-supply voltage, -7 V to -15 V (in stand-by -2 V to -15 V)</td></tr> <tr><td>Pin 12</td><td>+supply voltage, +7 V to +15 V (in stand-by +3 V to +15 V)</td></tr> <tr><td>Pin 13</td><td>Audio L- in/out, 2 V Bal, in relation to Audio L+, Rin 4.4 MW, Rout 150 Ω</td></tr> <tr><td>Pin 14</td><td>Audio L+ in/out, 2 V Bal, in relation to Audio L-, Rin 4.4 MW, Rout 150 Ω</td></tr> <tr><td>Pin 15</td><td>Audio R- in/out, 2 V Bal, in relation to Audio R+, Rin 4.4 MW, Rout 150 Ω</td></tr> <tr><td>Pin 16</td><td>Audio R+ in/out, 2 V Bal, in relation to Audio R-, Rin 4.4 MW, Rout 150 Ω</td></tr> <tr><td>Shield</td><td>GND</td></tr> </table>	Pin 1	Data-, -0.5 V ±0.2 V in relation to Data+	Pin 2	Data+, +0.5 V ±0.2 V in relation to Data-	Pin 3	ML connect > 3 V	Pin 4-6	+supply voltage, +7 V to +15 V (in stand-by +3 V to +15 V)	Pin 7-10	Not used	Pin 11	-supply voltage, -7 V to -15 V (in stand-by -2 V to -15 V)	Pin 12	+supply voltage, +7 V to +15 V (in stand-by +3 V to +15 V)	Pin 13	Audio L- in/out, 2 V Bal, in relation to Audio L+, Rin 4.4 MW, Rout 150 Ω	Pin 14	Audio L+ in/out, 2 V Bal, in relation to Audio L-, Rin 4.4 MW, Rout 150 Ω	Pin 15	Audio R- in/out, 2 V Bal, in relation to Audio R+, Rin 4.4 MW, Rout 150 Ω	Pin 16	Audio R+ in/out, 2 V Bal, in relation to Audio R-, Rin 4.4 MW, Rout 150 Ω	Shield	GND
Pin 1	Data-, -0.5 V ±0.2 V in relation to Data+																								
Pin 2	Data+, +0.5 V ±0.2 V in relation to Data-																								
Pin 3	ML connect > 3 V																								
Pin 4-6	+supply voltage, +7 V to +15 V (in stand-by +3 V to +15 V)																								
Pin 7-10	Not used																								
Pin 11	-supply voltage, -7 V to -15 V (in stand-by -2 V to -15 V)																								
Pin 12	+supply voltage, +7 V to +15 V (in stand-by +3 V to +15 V)																								
Pin 13	Audio L- in/out, 2 V Bal, in relation to Audio L+, Rin 4.4 MW, Rout 150 Ω																								
Pin 14	Audio L+ in/out, 2 V Bal, in relation to Audio L-, Rin 4.4 MW, Rout 150 Ω																								
Pin 15	Audio R- in/out, 2 V Bal, in relation to Audio R+, Rin 4.4 MW, Rout 150 Ω																								
Pin 16	Audio R+ in/out, 2 V Bal, in relation to Audio R-, Rin 4.4 MW, Rout 150 Ω																								
Shield	GND																								
Power Link	 <table border="1"> <tr><td>Pin 1</td><td>Power up (ON = >2.7 V -1mA)</td></tr> <tr><td>Pin 2</td><td>Signal GND</td></tr> <tr><td>Pin 3</td><td>Audio L out 0 V to 2 V RMS</td></tr> <tr><td>Pin 4</td><td>Speaker ON (ON = >2.7 V -1 mA)</td></tr> <tr><td>Pin 5</td><td>Audio R out 0 V to 2 V RMS</td></tr> <tr><td>Pin 6</td><td>Datalink out (High = >4 V, Low = <0.2 V)</td></tr> <tr><td>Pin 7</td><td>Data GND</td></tr> <tr><td>Pin 8</td><td>PL+ ON</td></tr> </table>	Pin 1	Power up (ON = >2.7 V -1mA)	Pin 2	Signal GND	Pin 3	Audio L out 0 V to 2 V RMS	Pin 4	Speaker ON (ON = >2.7 V -1 mA)	Pin 5	Audio R out 0 V to 2 V RMS	Pin 6	Datalink out (High = >4 V, Low = <0.2 V)	Pin 7	Data GND	Pin 8	PL+ ON								
Pin 1	Power up (ON = >2.7 V -1mA)																								
Pin 2	Signal GND																								
Pin 3	Audio L out 0 V to 2 V RMS																								
Pin 4	Speaker ON (ON = >2.7 V -1 mA)																								
Pin 5	Audio R out 0 V to 2 V RMS																								
Pin 6	Datalink out (High = >4 V, Low = <0.2 V)																								
Pin 7	Data GND																								
Pin 8	PL+ ON																								
Audio Aux Link	 <table border="1"> <tr><td>Pin 1</td><td>Audio L out 1 V RMS, Rout 1 kΩ</td></tr> <tr><td>Pin 2</td><td>GND</td></tr> <tr><td>Pin 3</td><td>Audio L in 0.25 V RMS to 2 V RMS, Rin 47 kΩ</td></tr> <tr><td>Pin 4</td><td>Audio R out 1 V RMS, Rout 1 kΩ</td></tr> <tr><td>Pin 5</td><td>Audio R in 0.25 V RMS to 2 V RMS, Rin 47 kΩ</td></tr> <tr><td>Pin 6-7</td><td>Not used</td></tr> </table>	Pin 1	Audio L out 1 V RMS, Rout 1 kΩ	Pin 2	GND	Pin 3	Audio L in 0.25 V RMS to 2 V RMS, Rin 47 kΩ	Pin 4	Audio R out 1 V RMS, Rout 1 kΩ	Pin 5	Audio R in 0.25 V RMS to 2 V RMS, Rin 47 kΩ	Pin 6-7	Not used												
Pin 1	Audio L out 1 V RMS, Rout 1 kΩ																								
Pin 2	GND																								
Pin 3	Audio L in 0.25 V RMS to 2 V RMS, Rin 47 kΩ																								
Pin 4	Audio R out 1 V RMS, Rout 1 kΩ																								
Pin 5	Audio R in 0.25 V RMS to 2 V RMS, Rin 47 kΩ																								
Pin 6-7	Not used																								
Headphones	 <p>Ø 3.5 mm, 220 W</p>																								
Digital output CD	 <table border="1"> <tr><td>AES / EBU</td></tr> <tr><td>IEC 958</td></tr> <tr><td>0.5Vpp, 75W, 1%</td></tr> </table>	AES / EBU	IEC 958	0.5Vpp, 75W, 1%																					
AES / EBU																									
IEC 958																									
0.5Vpp, 75W, 1%																									
Mains	 <table border="1"> <tr><td>Cable included</td></tr> <tr><td>Type 2571, 2572, 2577, 2580 – 230V AC</td></tr> <tr><td>Type 2573, 2576 – 120V AC</td></tr> <tr><td>Type 2574 – 100V AC</td></tr> <tr><td>Type 2575 – 240V AC</td></tr> </table>	Cable included	Type 2571, 2572, 2577, 2580 – 230V AC	Type 2573, 2576 – 120V AC	Type 2574 – 100V AC	Type 2575 – 240V AC																			
Cable included																									
Type 2571, 2572, 2577, 2580 – 230V AC																									
Type 2573, 2576 – 120V AC																									
Type 2574 – 100V AC																									
Type 2575 – 240V AC																									
Power frequency	50-60 Hz																								
Power consumption Stand.by	Typical 1.0W																								
Power consumption	Typical 15W																								

Dimensions

W x H x D	86.9 x 7 x 30.1 cm
Weight	11.5kg
Finish	Black, aluminium

Optional accessories

Beo4	Type 1624, 1625 (I)
Wall bracket horizontal	Type 2054
Wall bracket vertical	Type 2063
Bracket	Type 2053
Stand, adjustable in two heights	Type 2065
Cable cover	Type 2062
AM loop antenna	8720047
FM antenna	8720048

Type	Transformer	PCB5 Mains Relay	PCB34 Power Supply	PCB1 FM/AM	Mains cable
2571 EU	8013551 EU-230V AC	8005661 EU	8000512 EU	8000462 EU	6100273
2572 GB	8013551 EU-230V AC	8005661 EU	8000512 EU	8000462 EU	6100329
2573 US	8013549 US-120V AC	8005664 US	8000536 US	8000462 EU	6100307
2574 JAP	8013548 JAP-100V AC	8005661 EU	8000512 EU	8000535 JAP	6100331
2575 AUS	8013550 AUS-240V AC	8005661 EU	8000512 EU	8000462 EU	6100332
2576 TWN	8013549 US-120V AC	8005664 US	8000536 US	8000462 EU	6100307
2577 KOR	8013551 EU-230V AC	8005661 EU	8000512 EU	8000462 EU	6100386
2580 LAT	8013551 EU-230V AC	8005661 EU	8000512 EU	8000462 EU	6100273

Subject to change without notice

BRIEF OPERATION GUIDE

For more detailed operation see User's guide.

Closeup operation:

Loading CDs

- Press to raise the glass door
- Press to lower the glass door
- or
- Press to lower the door and start playing

CD playback

- Press to play a CD

- Press to play the next track on a CD
- or
- Press to play the same track again or press twice to play the previous track

- Press to pause playback
- Press to resume playing

Random

- Press to display [RANDOM ON] and cut in the random play function

- Press twice to display [RANDOM OFF] and cancel the random play function

- Press to switch to stand-by

Choosing a sequence of discs

- Press to start playback of a CD

- Press SELECT and [SELECT DISC] will appear on the display

Press the direct CD selection buttons next to the CDs you want to include...

- Press SELECT to start clearing a sequence and play all six CDs
- then
- Press to clear the sequence

Programming a series of tracks for one CD

- Press to play CD

- Press to scan the CD [EDITING?] appears on the display
- then
- Press to start scanning the tracks

- Press to include a track number in the series
- or
- Press to exclude a track number from the series

- [EDITING OK] appears on the display when you have included or excluded the last track...
- then
- Press to accept the track series

- To clear a track series...
- Choose the CD whose track series you want to clear
 - then
 - Press to access the programming option
 - then
 - Press to clear the track series altogether

Playing edited CDs

- Press to start playback of a CD
- then
- Press to display [EDIT ON] and start edited playback

- Press twice to play a CD in full and cancel EDIT – [EDIT OFF] appears on the display

Positioning CDs

- Load and adjust a CD manually...
- Then press the direct CD selection button next to this CD to move the carriage to the CD ...
-
- then
- Press to access the positioning function for CDs
- then
- Press to store the position for this CD

Repeat this procedure for all the CDs you have loaded...

If you want to clear the positions for a CD, move the carriage to the CD in question...

- Press to access the positioning function to clear the position
- then
- Press to clear the position

Naming CDs

- Press to play CD
- then
- Press to access the naming function
- then
- Press to reveal the characters or numbers one by one
- or
- Press to move to next character position
- then
- Press to store the name

- Press while you are naming CDs or track series in order to automatically store the name and exit the naming function

To clear a name, follow this procedure...

- Press to access the naming function
- then
- Press to clear the name
- then
- Press to return to normal source operation

Listing CDs

- Press to play CD

- Press to access the naming list [CD LIST] appears briefly, then the name of the current CD appears

- Press to list the names one by one and return to names further up the list

- Press to clear a name while the appropriate name is displayed

- Press to return to normal source operation

Playing your radio programs

- RADIO** Press to turn on the radio

- ▲** Press to step through your radio programs
or
▼

- Press to switch to stand-by

Presetting radio stations

- RADIO** Press to turn on the radio
- TUNE** Press to start the tuning function
- AM/FM** Press to select [AM] or [FM], switches from one to the other, check display for an indication of which one you have chosen
- then
▲ Press to search for a radio station up or down the frequency band
or
▼
then
OK Press to accept the station you have found

- P. NO.** Press to change the displayed program number
- then
▲ Press to select for a program number – up or down
or
▼
then
OK Press to store your new radio program – [STORED] appears on the display

Fine tuning a radio station

- RADIO** Press to turn on the radio program you want to fine tune
- TUNE** Press to start the fine tuning function
then
TUNE
- ▲** Press to fine tune your program towards a higher or lower frequency
or
▼
then
OK Press to accept your fine tuned program
- then
OK Press again to store program and program number

Mono/stereo reception

- RADIO** Press to turn on the relevant radio program
- TUNE** Press to choose [MONO] or [STEREO]
then
TUNE
then
TUNE
then
▲ Press to switch from stereo to mono
or
▼
- OK** Press to store your new tuning on the program number

Clearing presets...

- RADIO** Press to turn on the radio
- ▲** Press to search for program number
or
▼
- CLEAR** Press to clear the program
then
OK Press to confirm the clearing of the radio program

Naming radio programs

- RADIO** Press to turn on the radio program you want to name
- NAMING** Press to start the naming function. The first of the twelve character positions blinks, indicating that you can start "writing" a name
- ▲** Press to reveal the characters one by one
or
▼ Press to reveal previously shown characters
- then
OK Press to move to the next character position
- then
OK Press to store the name of the radio station [NAMING OK] will appear on the display
- or
RADIO Press to store the name and exit the naming function. You can press RADIO at any time to store and exit the naming function

To clear a name...

- NAMING** Press to access the naming function
then
CLEAR Press to clear the name

Playing auxiliary sources

- A. AUX** Press to select extra equipment

Adjusting sound

- VOL ▲** Press to raise the volume
- VOL ▼** Press to lower the volume
- TREBLE** Press to access treble
- BASS** Press to access bass
- BALANCE** Press to access balance
- ▲** Press to raise or lower the treble and bass levels; or adjust the balance between the left and the right speaker
or
▼
- LOUDNESS** Press to see the status of the loudness adjustment function – [LOUDNESS ON] or [LOUDNESS OFF]. Press LOUDNESS again to change the setting
- OK** Press to accept all sound levels - [SOUND OK?] appears on the display
- then
OK Press to store all sound levels

If you have not stored your sound adjustments...

- RESET** Press to reset the sound levels to their previously stored settings

Switching displays, example

- RADIO** Press to turn on the radio
- OK** Press repeatedly to change the radio display indication

Programming Timers

- TIMER** Press to start programming timers
- then
▲ Press to choose a source for your Timer or choose a Timer stand-by
or
▼
then
OK Press to accept the Timer
- Then program when you want the Timer to start and stop...
- ▲** Press repeatedly until you have found the exact time for starting a Timer play
or
▼
then
OK Press to accept start

Repeat the procedure with the ▲ and ▼ buttons and OK to program the exact timer for stopping a Timer

To program a [SINGLE DATE] Timer...

- ▶ Press to display the date you want to program a Timer for
- ▶ Press to accept the selection
- ▶ Press to store your Timer programming and return to normal source operations

Checking or clearing Timers

- ▶ Press to check your timers
- ▶ Press to see timer programming number, source and program number of individual timer entries
- ▶ Press repeatedly to display the details of a particular programming

- When the display reads [OK ?]
- ▶ Press to display [NEXT ?] to see your next timer programming entry
- ▶ Press to see your next entry – If there are no more entries, [NO MORE], will appear on the display

- ▶ Press clear while information regarding a timer programming is displayed on the display – [CLEARED] will appear on the display after pressing CLEAR

Setting and using the built-in clock

- ▶ Press to call up the built-in clock
- ▶ Press to set time, date/month or year...
- ▶ Press to accept the changes and reveal the next display - Repeat this setting procedure for date/month and year...
- When you have set or changed the year, the display now reads [CLOCK OK?]
- ▶ Press to store your new setting of the clock

- ▶ Press to show the clock
- ▶ Press to see the date and year
- To display the clock permanently...
- ▶ Press when Date and Year is displayed and change the display to time and ON e.g. [14:40 ON] – press again to cancel the permanent showing of the clock e.g. [14:41 OFF].

Option programming Beo4

- hold
- ▶ while pressing
- ▶ Until the Beo4 display reads OPTIONS?
- then
- ▶ Until the display reads A:OPT
- then
- ▶ Disable the remote control function
- or
- ▶ Enable the remote control function

Option programming BeoLink 1000

- ▶ Disable the remote control function
- or
- ▶ Enable the remote control function

Automatic demonstration

The product can be brought into automatic demonstration mode in which it plays back 90 randomly chosen tracks. Each track is played back for 20 seconds.

Load six CD's with at least ten tracks each.

Bring the product into stand-by.

Press: SHIFT 9 1 9 9 6.
The remote control terminal must be in audio mode.
(SHIFT is found under LIST on Beo4)

The automatic demonstration can be stopped by bringing BeoSound 9000 into stand-by, which is done by actuating stand-by on the product.

During the automatic demonstration the sound will be muted. Demute the product if you want sound.

Locking of glass lid

The glass lid can be locked so that it cannot be operated on the product.

Press: SHIFT 9 0 3 6 9.
The remote control terminal must be in audio mode.

The display reads: LOCK.

The function is stopped by pressing: SHIFT 9 0 3 6 9.
The remote control terminal must be in audio mode.

SHIFT is found under LIST on Beo4

The display reads: UNLOCK.

Centering the CD drive mechanism

The sledge must be in position 1.

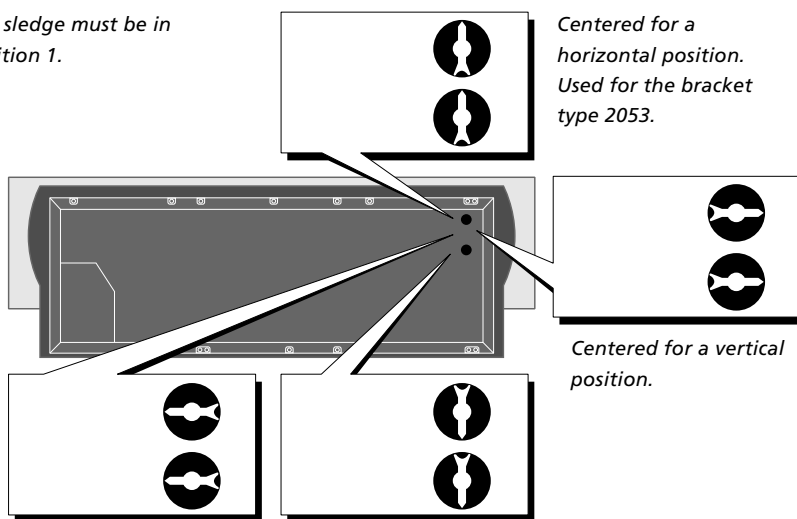

Centered for a flat or near flat position. This is the factory setup.

Centered for a horizontal position. Used for the bracket type 2054.

The PIN-code system

Activate the PIN-code system

While the BeoSound 9000 is in stand-by mode you can set up the PIN-code.

▼ ▼ PAUSE NEW PIN	Press ▼ twice followed by PAUSE to activate the PIN-code function. The display shows NEW PIN for 1.5 sec....
PIN _ _ _ _	...then you can enter a PIN-code
▲ ▼	Press to select a digit*
OK	Press to accept the digit

The digit is replaced by a * and the next underscore blinks. Continue to enter the last three digits in the same manner.

If you wish to change the entered digits...

RESET	Press to start entering from the beginning
--------------	--

When the PIN-code has been entered...

OK	Press to accept the PIN-code. The display shows CONFIRM for 1.5 sec....
CONFIRM	

PIN _ _ _ _	...then re-enter the PIN-code
-------------	-------------------------------

OK	Press to confirm the PIN-code
-----------	-------------------------------

STORED	The display shows that your setting is stored
--------	---

If an incorrect code is entered the second time you must set up the PIN-code from the beginning.

Change or delete your PIN-code

While the PIN-code function is turned on you can always make changes to the PIN-code.

▼ ▼ PAUSE PIN _ _ _ _ NEW PIN?	Press ▼ twice followed by PAUSE to activate the PIN-code function. Enter the current PIN-code. The display shows NEW PIN?
▲ ▼ NEW PIN? PIN OFF?	Press to choose from the two options NEW PIN? or PIN OFF?

Select NEW PIN? to change your PIN-code

PIN _ _ _ _	Enter the new PIN-code
OK CONFIRM	Press to accept the new PIN-code. The display shows CONFIRM for 1.5 sec....

PIN _ _ _ _	...then re-enter the new PIN-code
-------------	-----------------------------------

OK	Press to confirm the new PIN-code
-----------	-----------------------------------

STORED	The display shows that your new PIN-code is stored
--------	--

Select PIN OFF? to delete your PIN-code

DELETED	The PIN-code function is disabled and the display shows DELETED for 3 sec.
---------	--

For security reasons it is only possible to change or verify the PIN-code five times within a period of 3 hours. If an incorrect code is entered five times, BeoSound 9000 is turned off, and must be left in stand-by mode for 3 hours, before you may try again.

Using your PIN-code

When a PIN-code has been programmed, and the BeoSound 9000 has been disconnected from the mains for more than 30 minutes, you must enter the PIN-code when the BeoSound 9000 is turned back on.

PIN _ _ _ _	Enter the PIN-code
▲ ▼	Press to select a digit
OK	Press to accept the digit
RADIO 1	When the PIN-code has been entered the display returns to the relevant source display e.g. RADIO 1

If an incorrect PIN-code is entered the display will show ERROR and you may try again. After the fifth try, the BeoSound 9000 is turned off, and must be left in stand-by mode for 3 hours, before you can try again.

Did you forget your PIN-code?

Should you forget your PIN-code you can require a five-digit Master Code from your Bang & Olufsen retailer.

When you have received a Master Code...

PIN _ _ _ _	When the display is open for PIN-code input...
-------------	--

▼ PIN _ _ _ _ _	Press the ▼ button for more than 3 seconds to change the display to fit 5 digits
--------------------	--

PIN _ _ _ _ _	Enter the Master Code
---------------	-----------------------

▲ ▼	Press to select a digit
--------	-------------------------

OK	Press to accept the digit
-----------	---------------------------

DELETED	The display shows that the PIN-code lock is off
---------	---

When the Master Code is entered, the BeoSound 9000 can be used without entering the code again.

*NOTE!: It is also possible to enter the digits using the number keys 0 – 9 on your Beo4 remote control.

Explanation of diagram

Type numbers of transistors and ICs are indicated on the diagrams. If the position is followed by an asterisk the spare part number must always be used because the component in question has been specially selected, e.g. IC4*.

Component print and coordinate system

The largest PCBs have component prints and a coordinate system on both the primary and the secondary side.

On the diagrams every component has a coordinate number.

This indicates in which coordinate on the PCB the component is situated. The coordinate numbers are written in smaller print types than the position numbers.

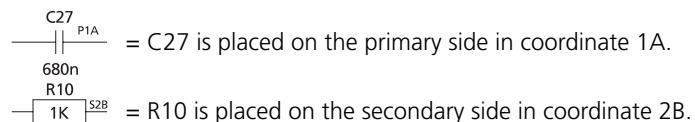

Control circuit

In certain control circuits the active mode is indicated by a function term or by an abbreviation. This may be e.g. $\overline{\text{ST.BY.}}$ = low in the stand-by mode or ST.BY. = high in the stand-by mode.

Wiring connections

The wiring connections on the diagrams are assembled in 'bundles'.

The individual wires are provided with one of the following codes:

INTERNAL CONNECTION ON ONE DIAGRAM PAGE



Internal connections on a diagram page are indicated by a number. The bend of the wire indicates in which direction the other end of the wire is found.

CONNECTION TO ANOTHER DIAGRAM PAGE



A connection to another diagram page is indicated by a number as well as by a letter of the diagram to which the connection leads.

Ground symbols

Three different ground symbols are used in the set.

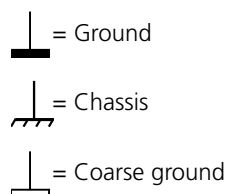

Symbol of safety components



When replacing components with this symbol, components with identical part numbers must be used. The new component must be mounted in the same way as the one replaced.

Measuring conditions

All DC voltages have been measured in relation to ground with a voltmeter with an input impedance of 10 Mohms.

The DC voltages are stated in volts (V), e.g. 0.7V.

All oscillograms and AC voltages have been measured in relation to ground with an oscilloscope or a voltmeter with an input resistance of 1Mohm.

AC voltages are stated in millivolts (mV), e.g. 660mV.

Caution

The use of any controls, adjustments or procedures other than those specified herein may result in hazardous radiation exposure.



The black and yellow label on the compact disc player serves as a warning that the apparatus contains a laser system and is classified as a class 1 laser product. The apparatus must be opened by qualified servicemen only.

CD laserdiode

Wavelength 780 nm \pm 20 nm, 30°C

Effect 2 mW \pm 0.1 mW, 30°C

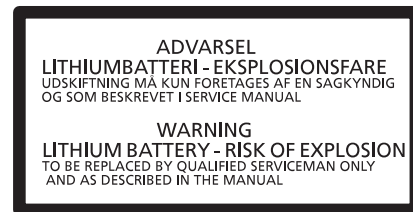
Lithium battery**WARNING**

Short-circuit and overcharging of some types of lithium batteries may result in a violent explosion.

When replacing the lithium battery in this set, note the following:

Use only batteries of the same make and type as mentioned in this service manual (see page 3.9).

Place the battery exactly like the old one.

Explanation of the fuse symbols used in the set

Replace with the same type 1 ampere 250 volts quick acting fuse.

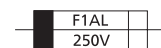

Replace with the same type 2.5 ampere 250 volts slow acting fuse.

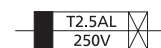
**Explanation des symboles de fusible utilisés dans l'appareil**

Remplacer par un fusible rapide de même type et de 1 ampères 250 volts.

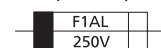

Remplacer par un fusible retardè de même type et de 2.5 ampères 250 volts.

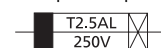

Wiring diagram

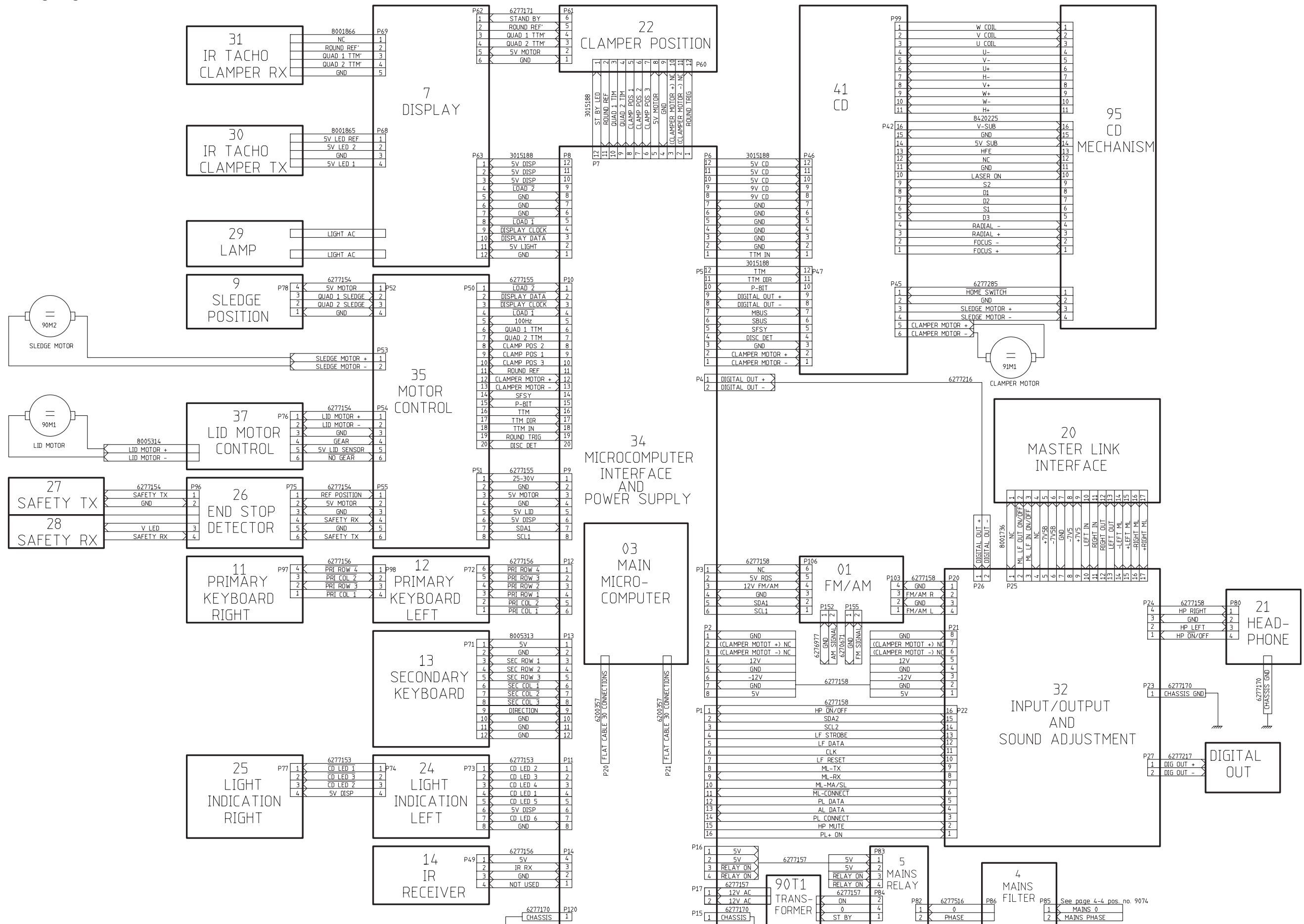

Overall block diagram

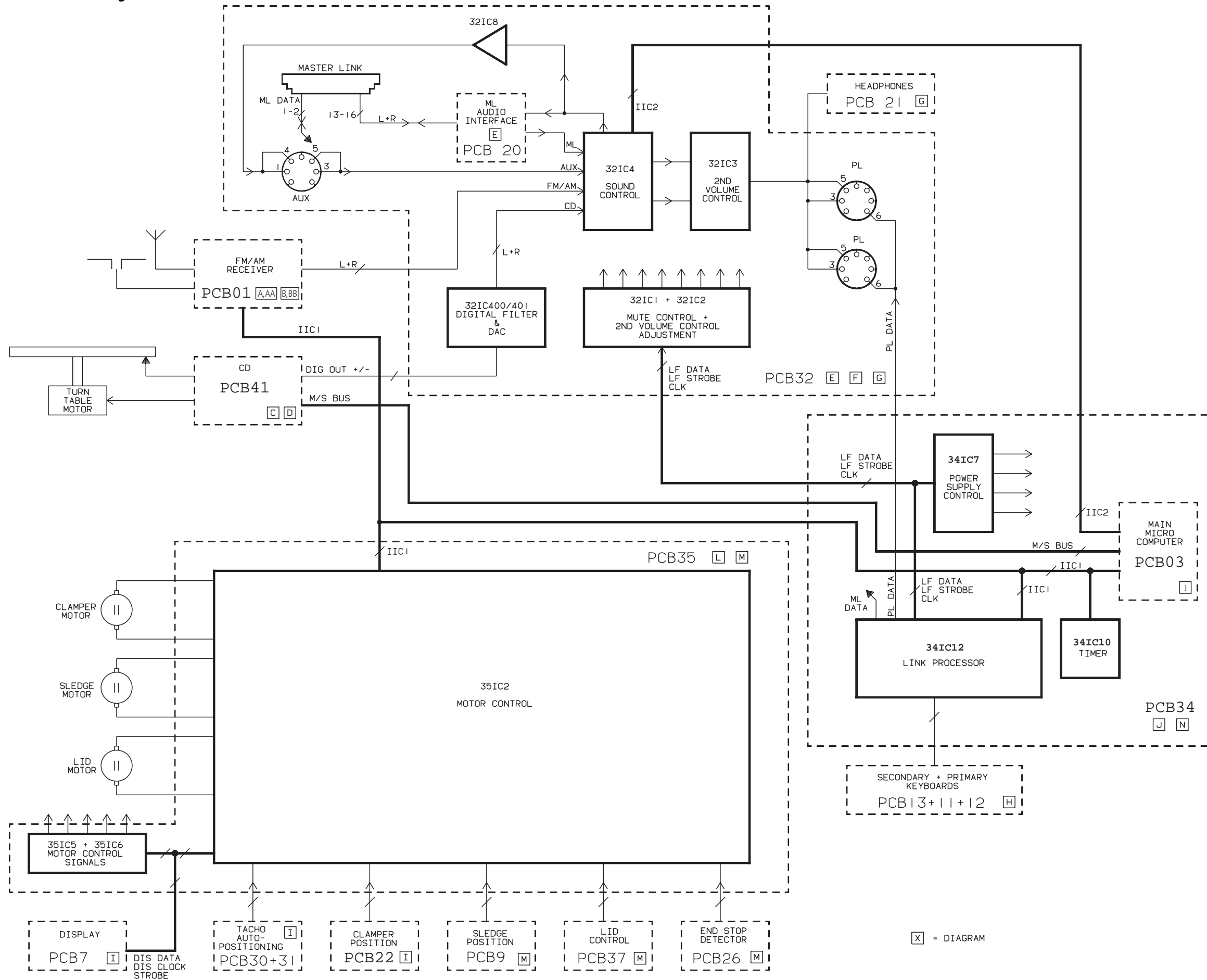

Block diagram for AM

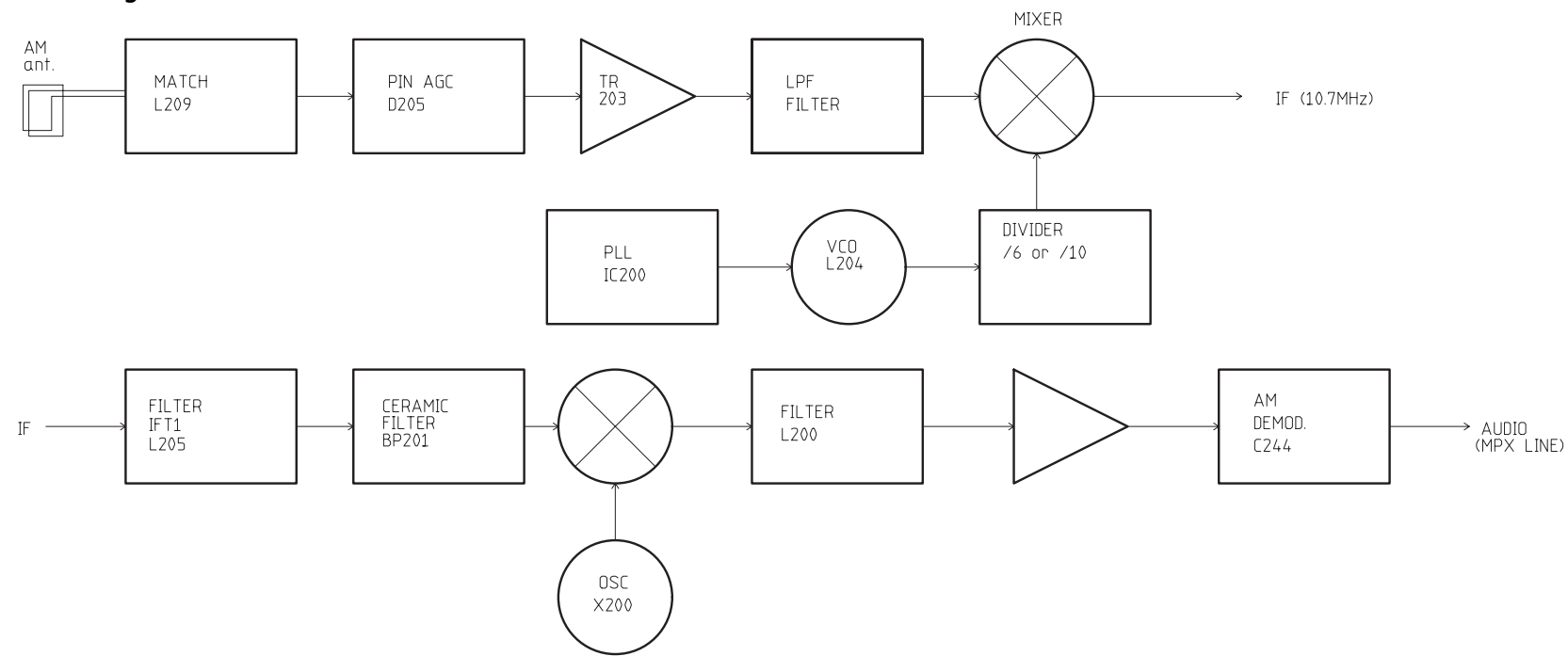

Block diagram for Frontend Tuner

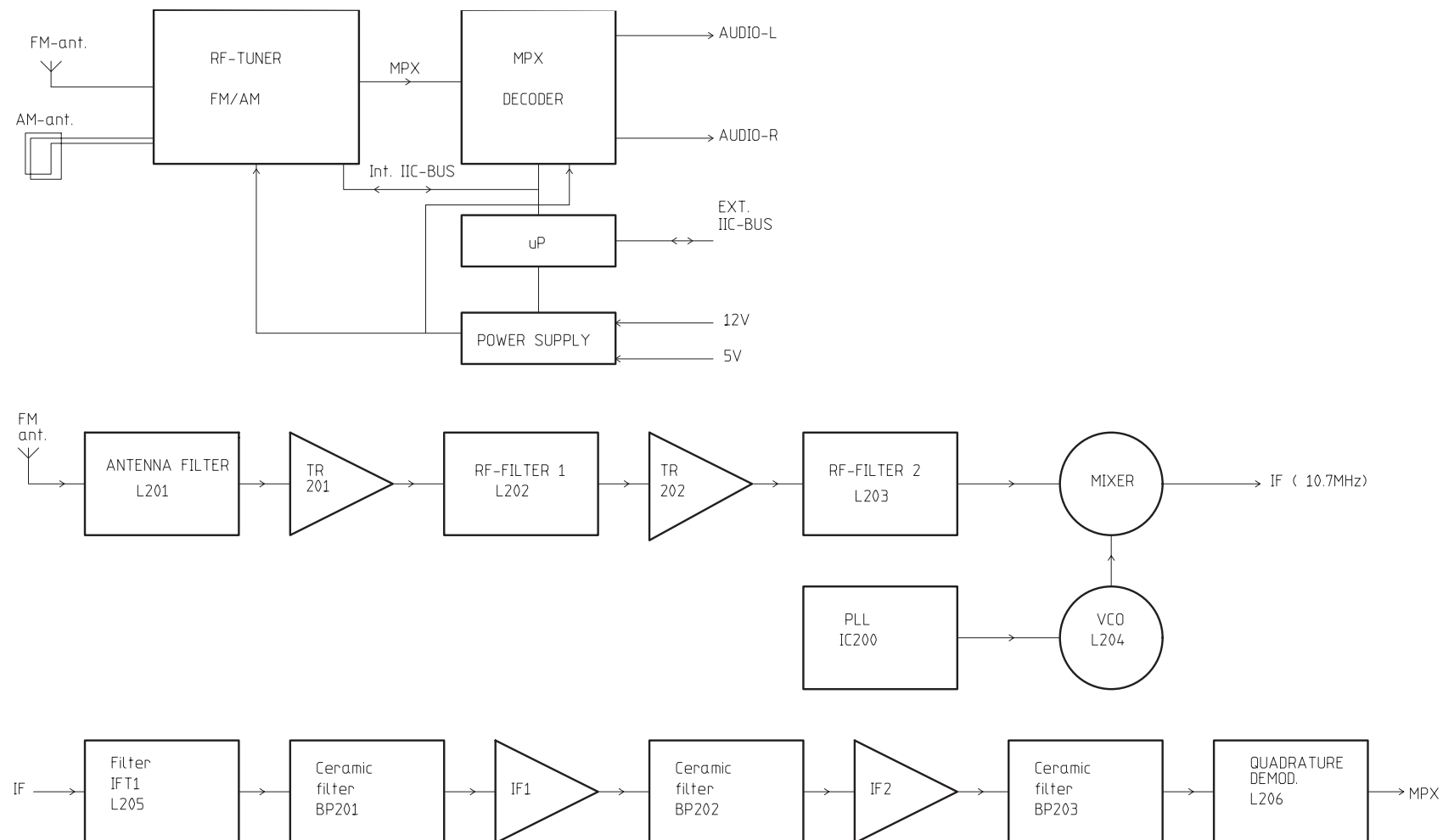

Block diagram for CD

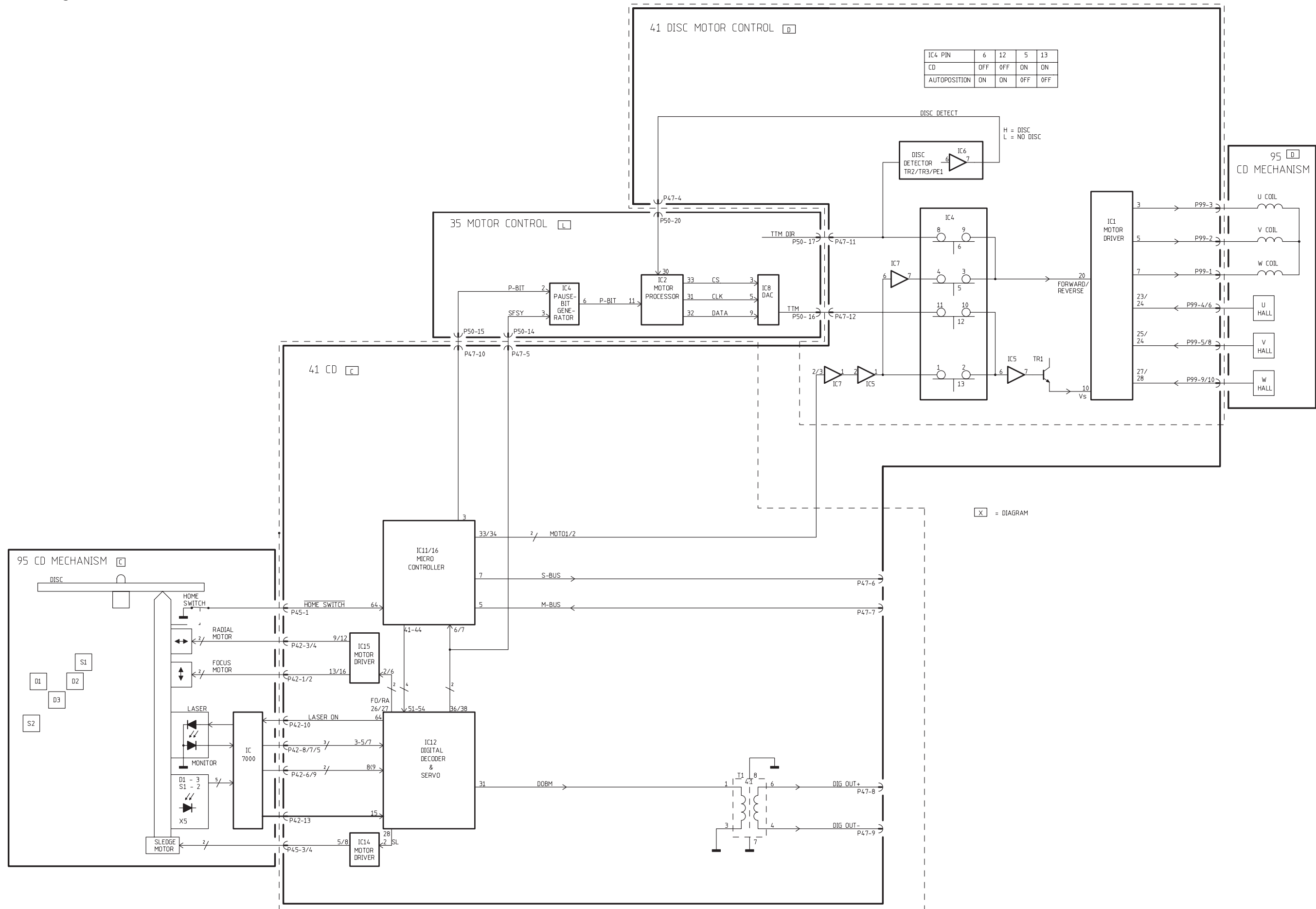

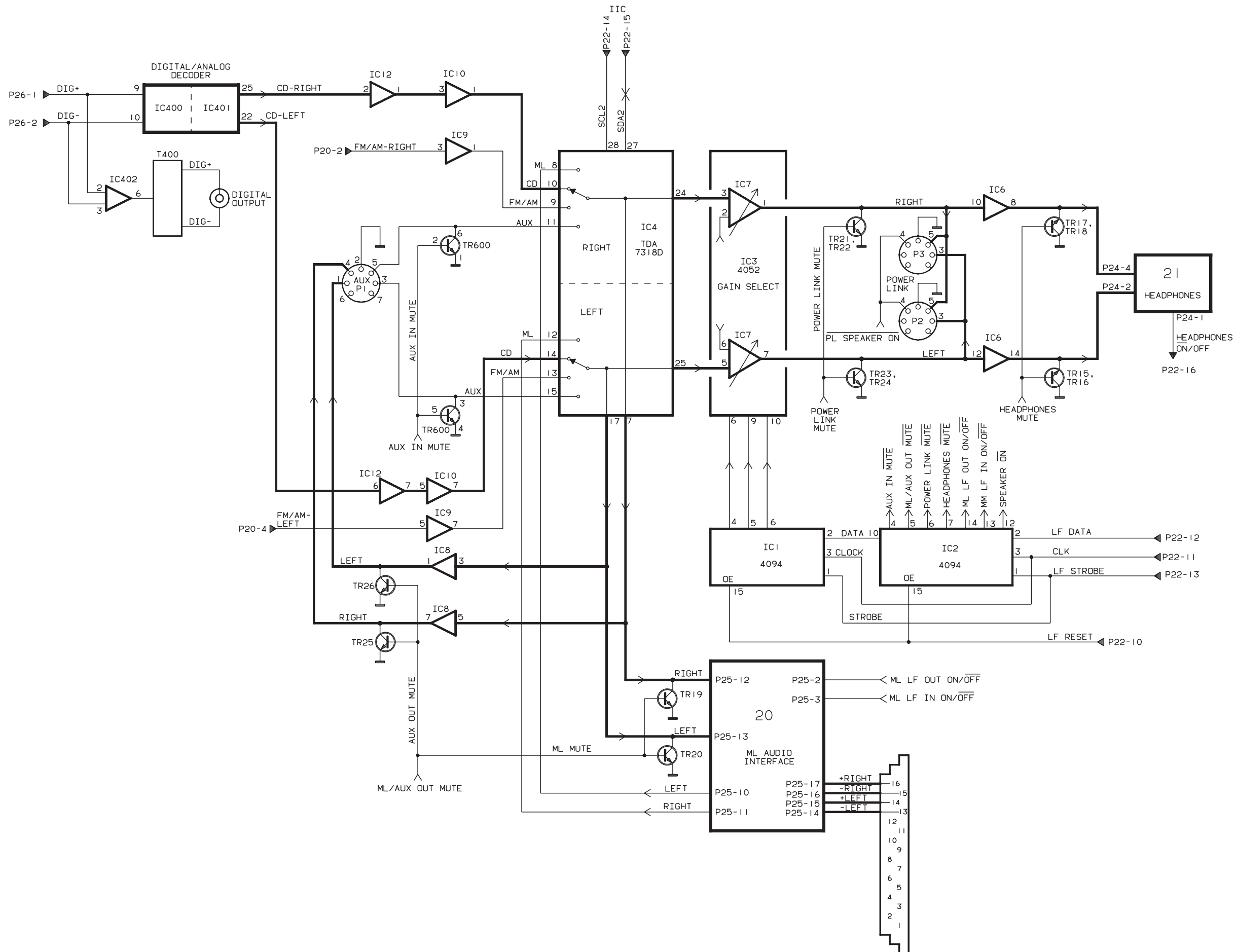

Block diagram for Data

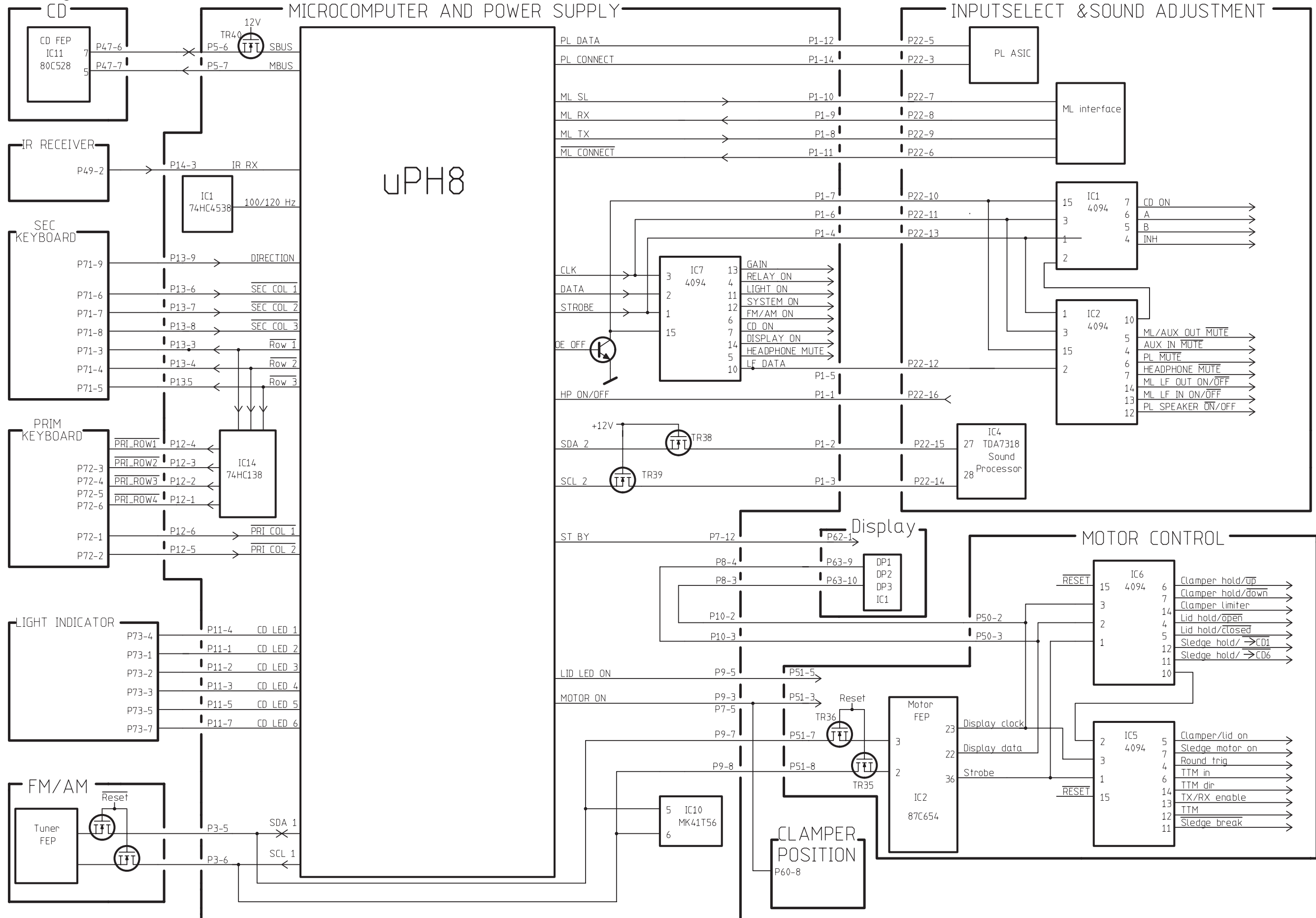

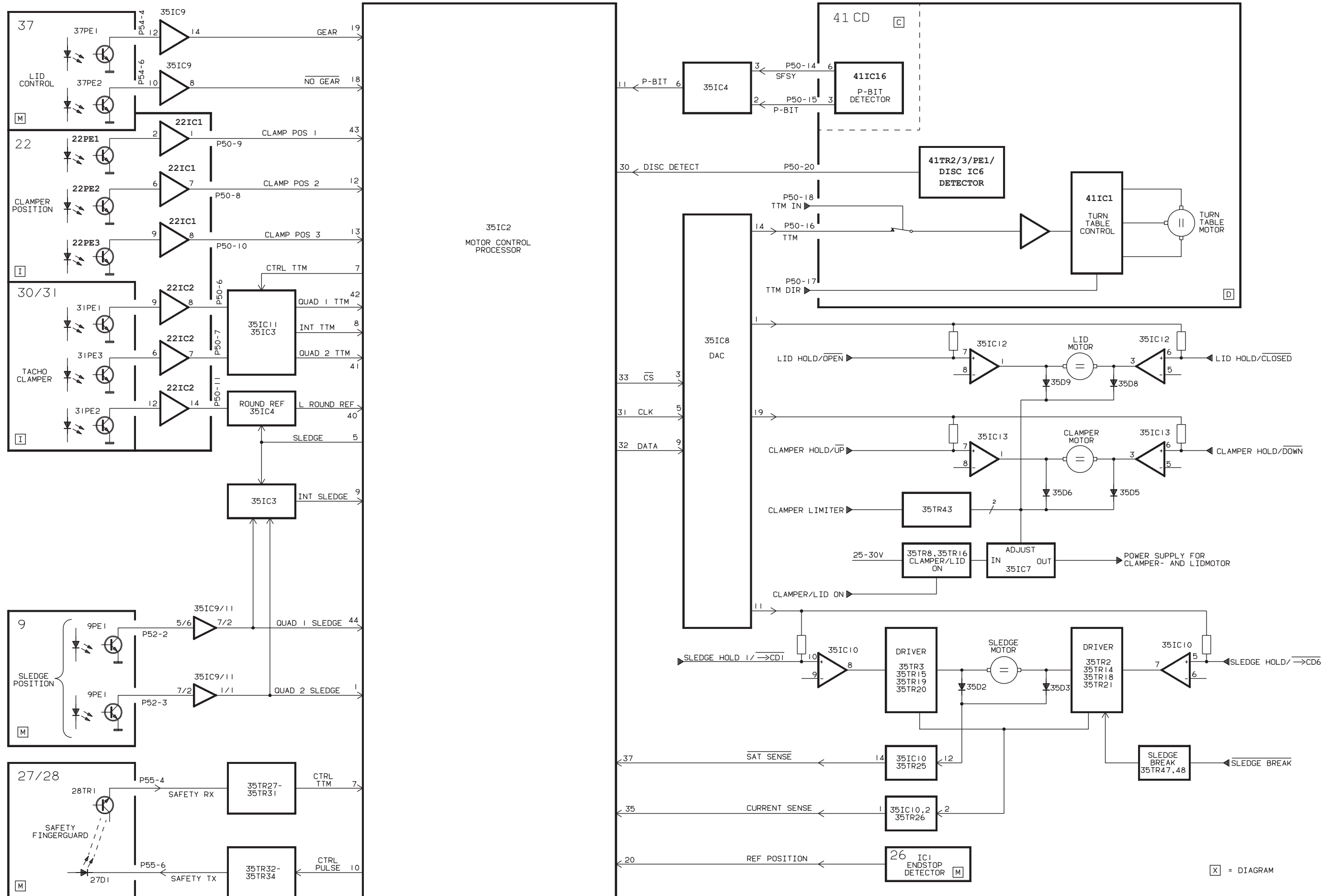

Block diagram for Power Supply

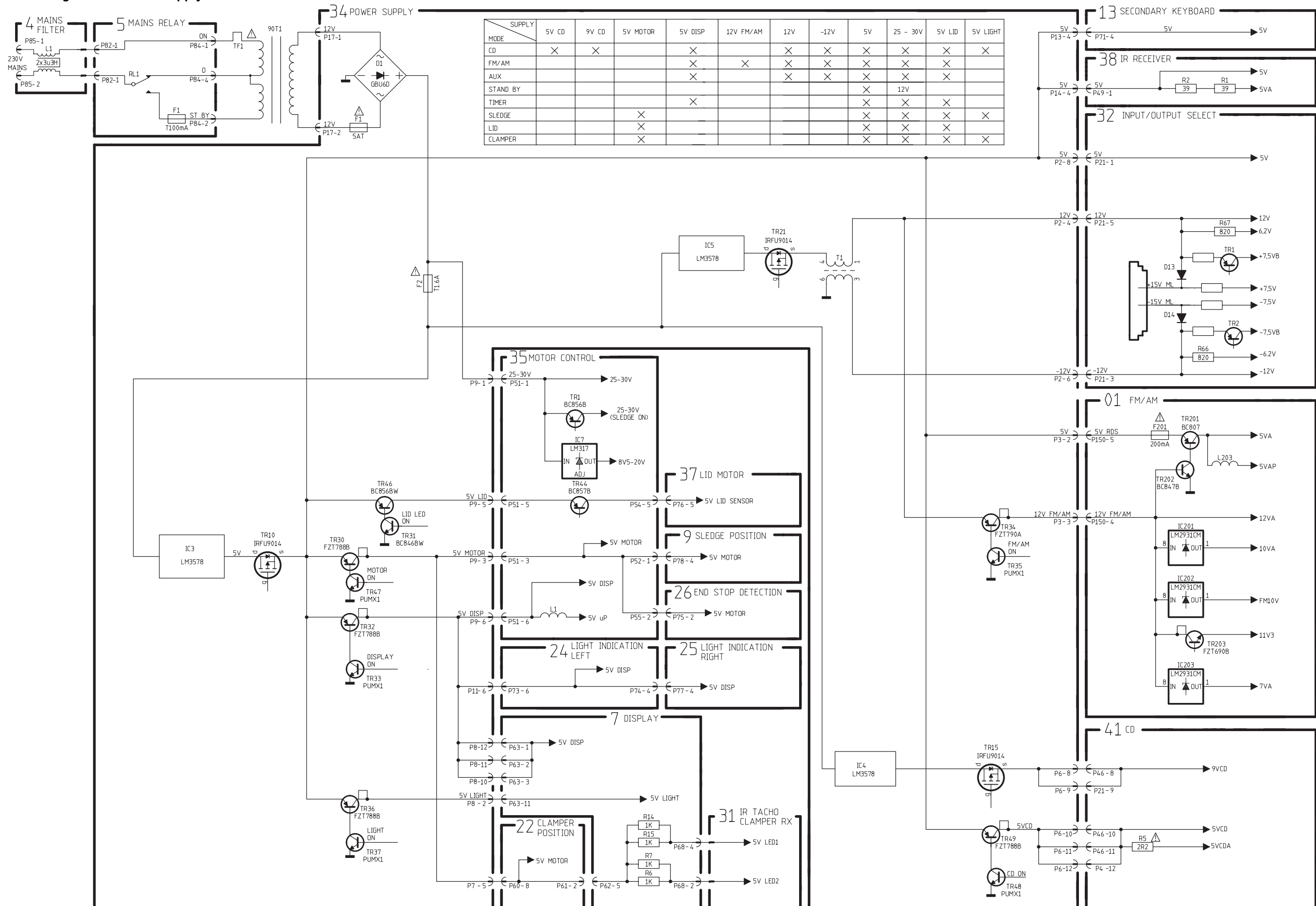

DIAGRAM A – Frontend tuner

PCB drawing for PCB1 see page 2.15

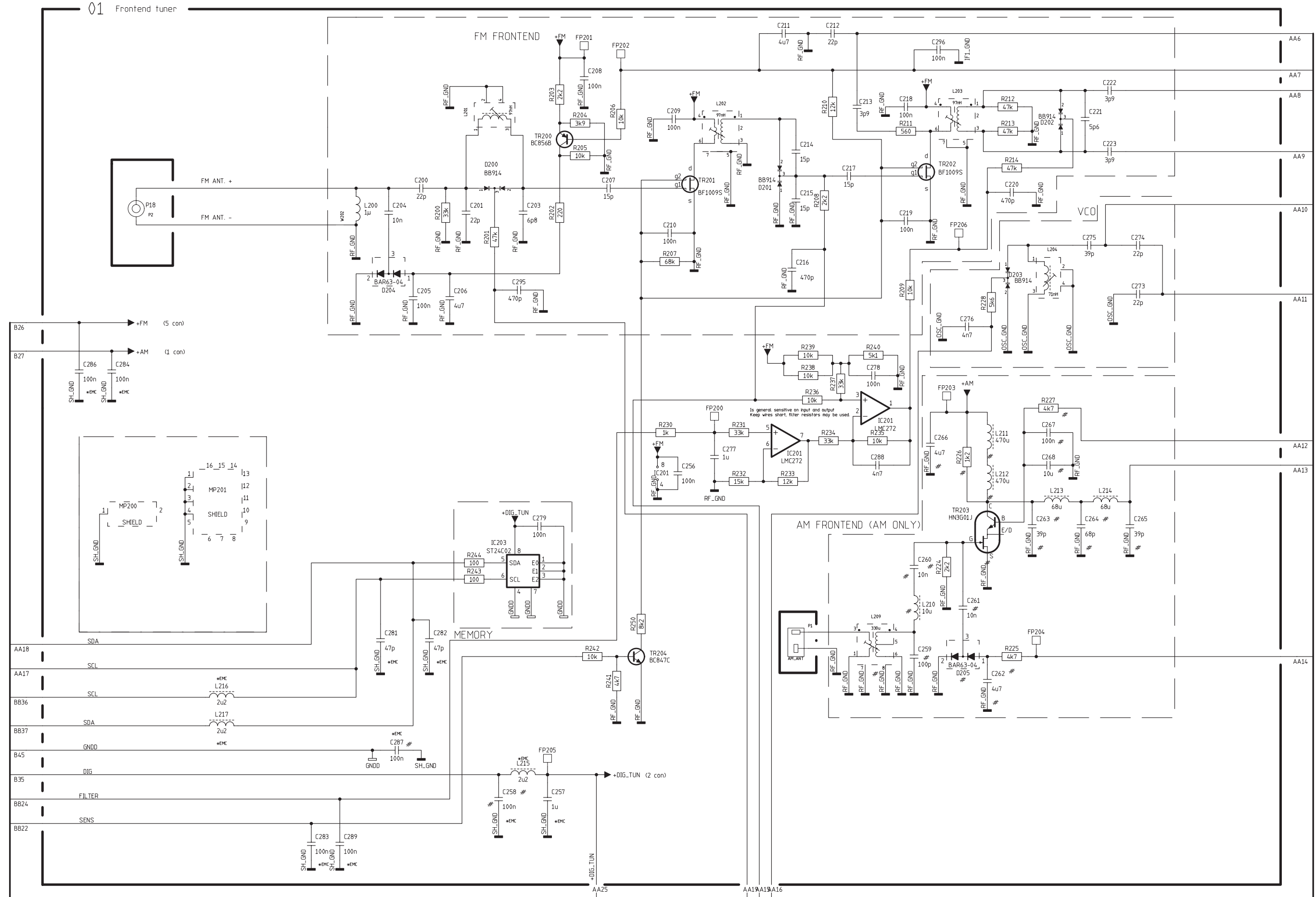
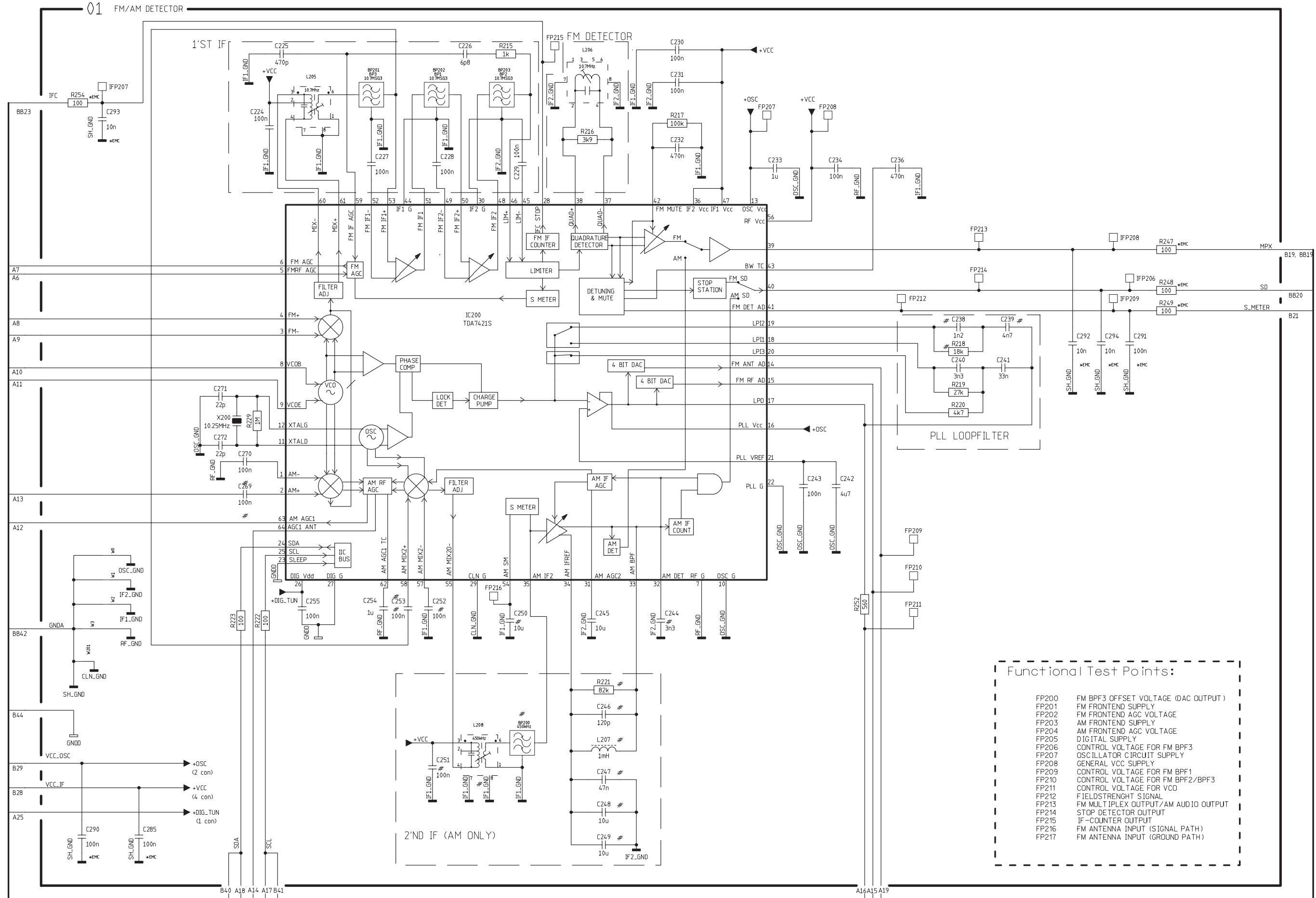

DIAGRAM AA – FM/AM detector PCB drawing for PCB1 see page 2.15



- Functional Test Points:
- FP200 FM BPF3 OFFSET VOLTAGE (DAC OUTPUT)
 - FP201 FM FRONTEND SUPPLY
 - FP202 FM FRONTEND AGC VOLTAGE
 - FP203 AM FRONTEND SUPPLY
 - FP204 AM FRONTEND AGC VOLTAGE
 - FP205 DIGITAL SUPPLY
 - FP206 CONTROL VOLTAGE FOR FM BPF3
 - FP207 OSCILLATOR CIRCUIT SUPPLY
 - FP208 GENERAL VCC SUPPLY
 - FP209 CONTROL VOLTAGE FOR FM BPF1
 - FP210 CONTROL VOLTAGE FOR FM BPF2/BPF3
 - FP211 CONTROL VOLTAGE FOR VCO
 - FP212 FIELDSTRENGTH SIGNAL
 - FP213 FM MULTIPLEX OUTPUT/AM AUDIO OUTPUT
 - FP214 STOP DETECTOR OUTPUT
 - FP215 IF-COUNTER OUTPUT
 - FP216 FM ANTENNA INPUT (SIGNAL PATH)
 - FP217 FM ANTENNA INPUT (GROUND PATH)

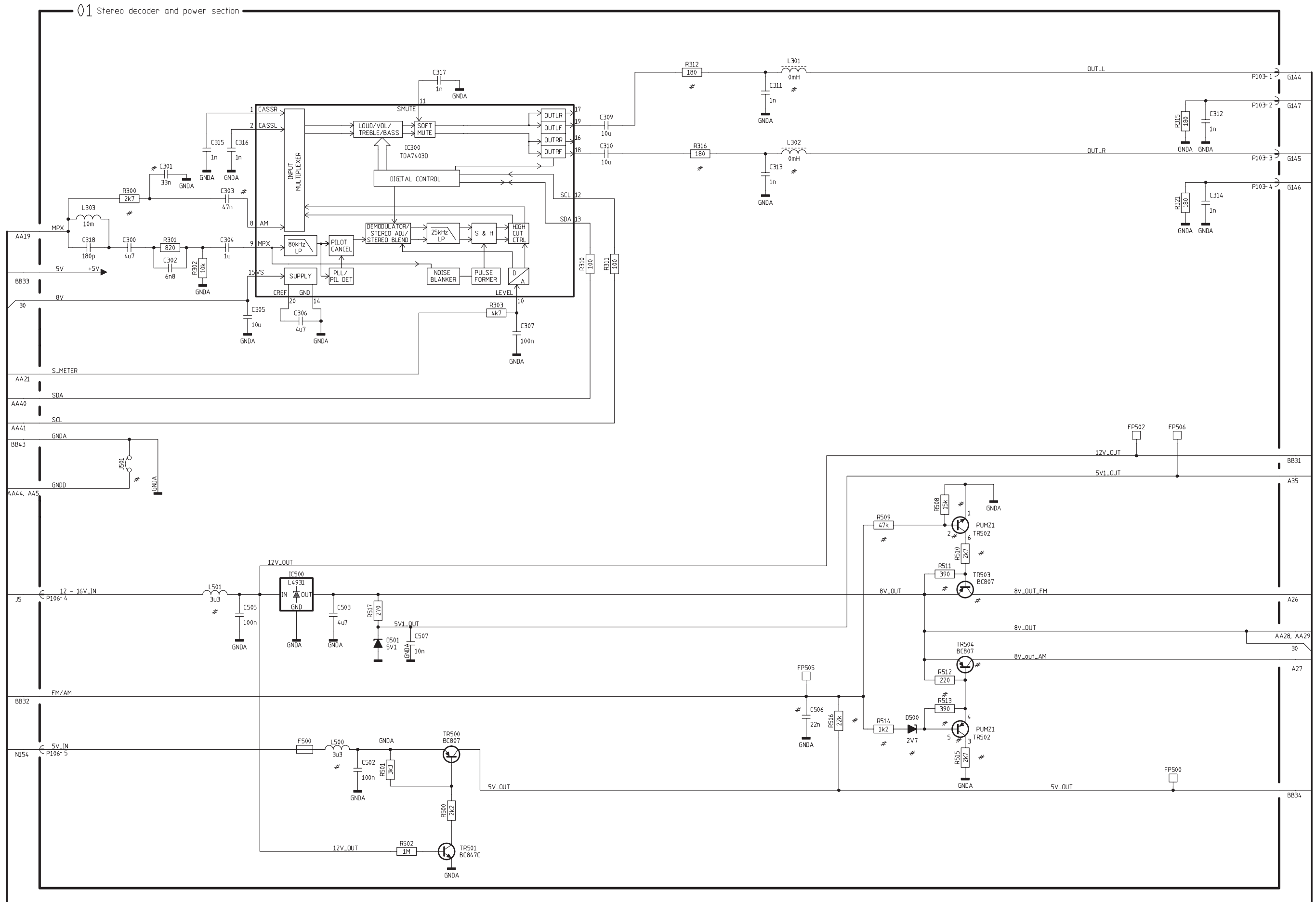
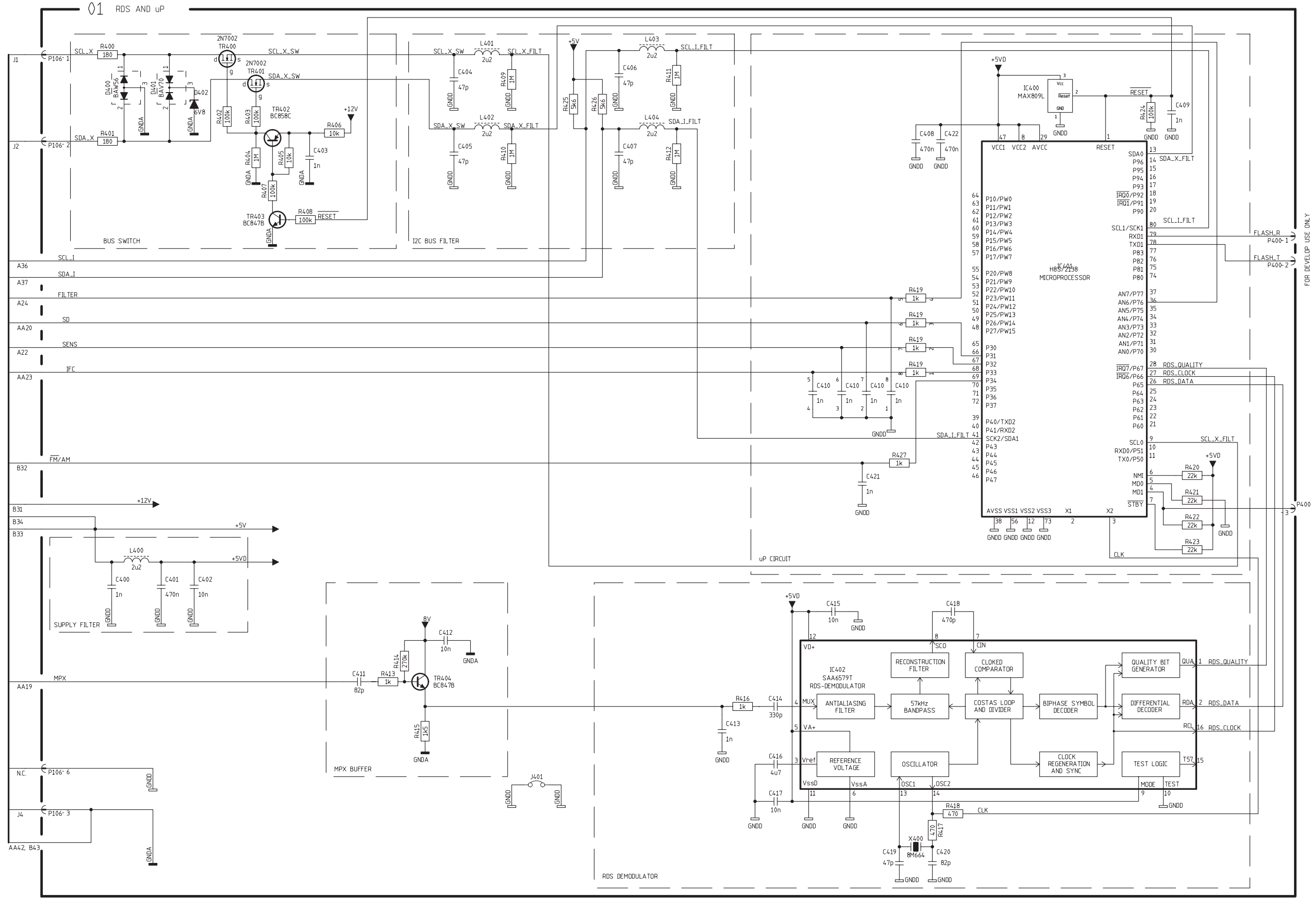

DIAGRAM BB – RDS and μP PCB drawing for PCB1 see page 2.15



FOR DEVELOP USE ONLY

FOR DEVELOP USE ONLY

PCB1, FM/AM - RDS - secondary side

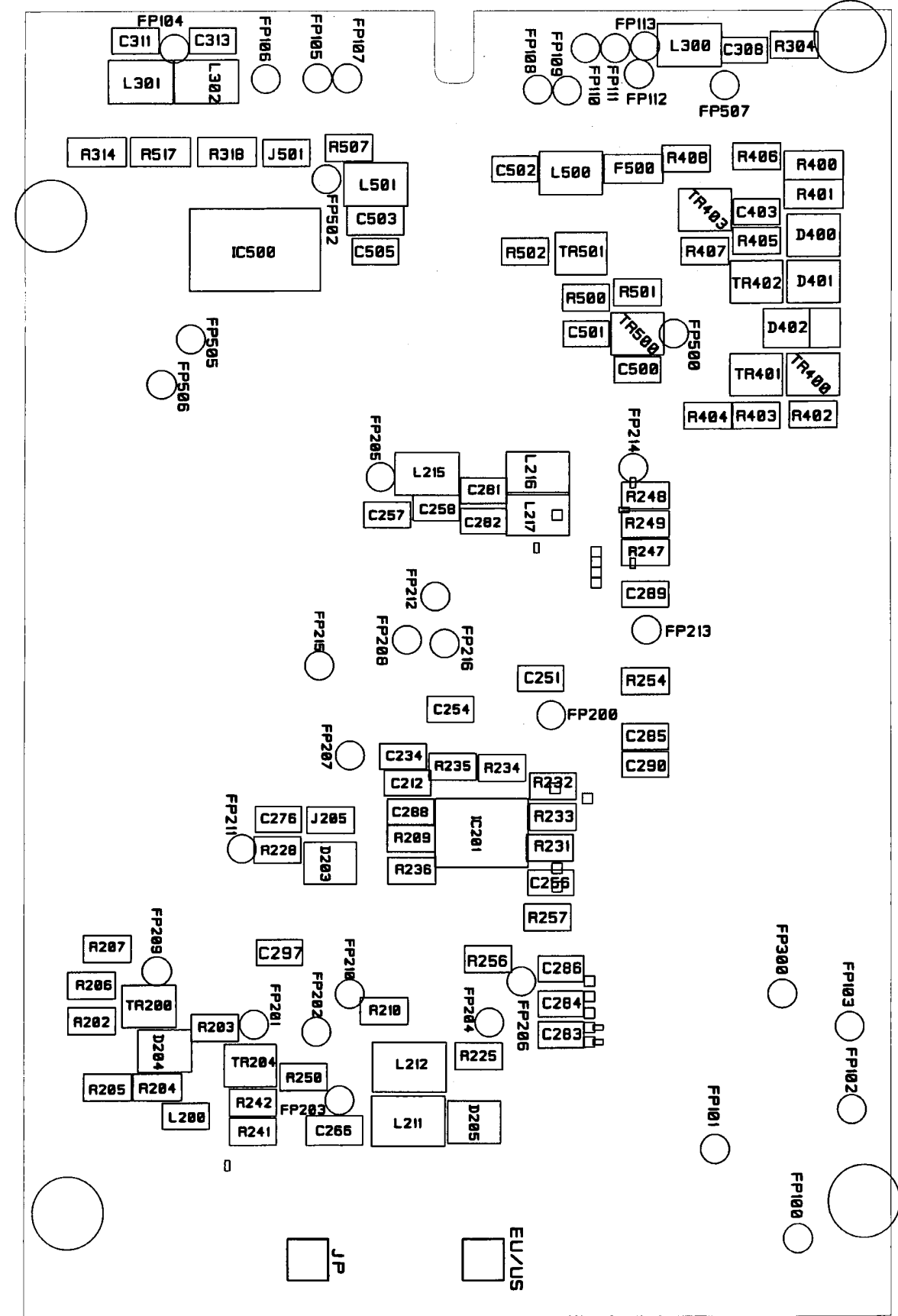
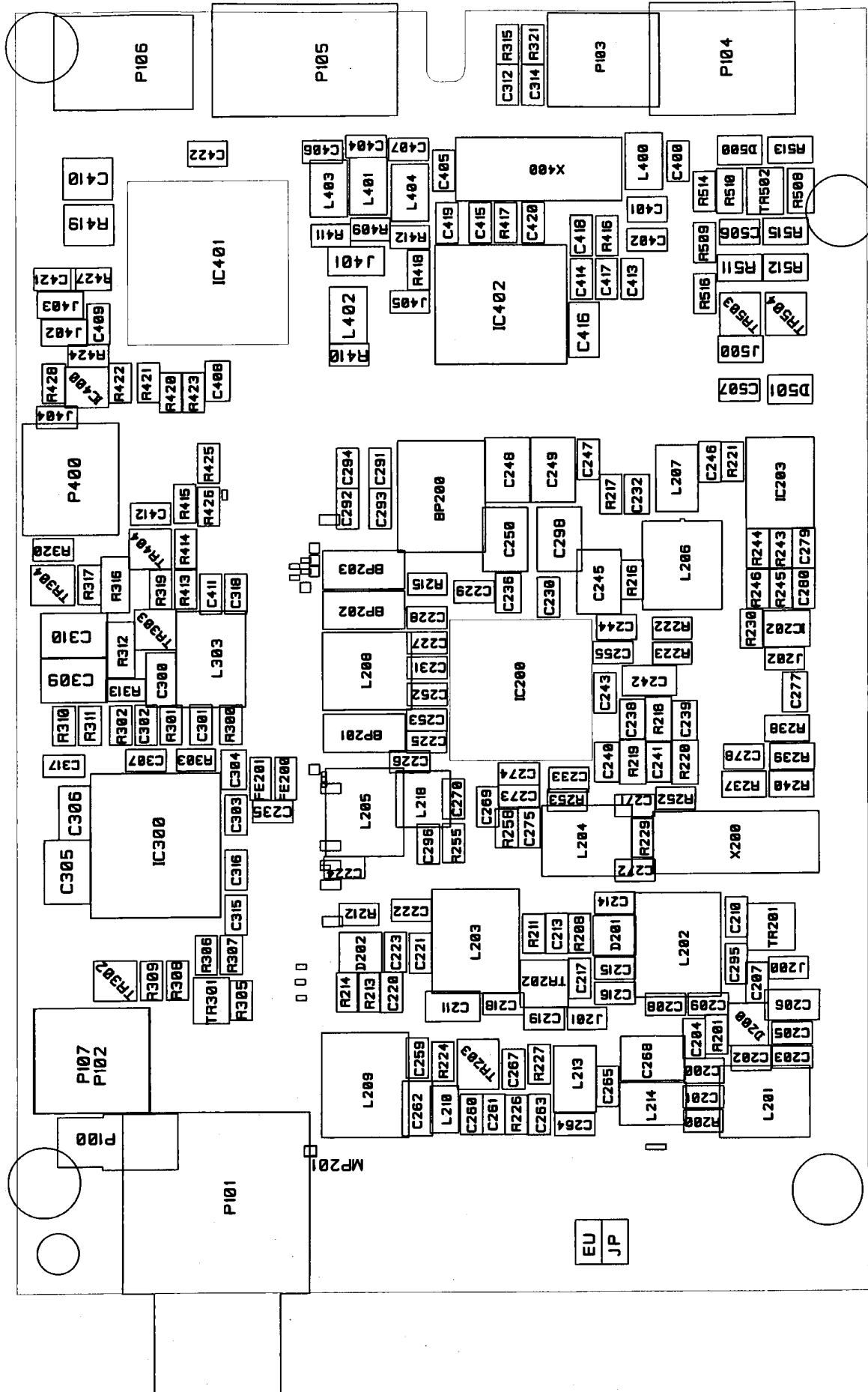
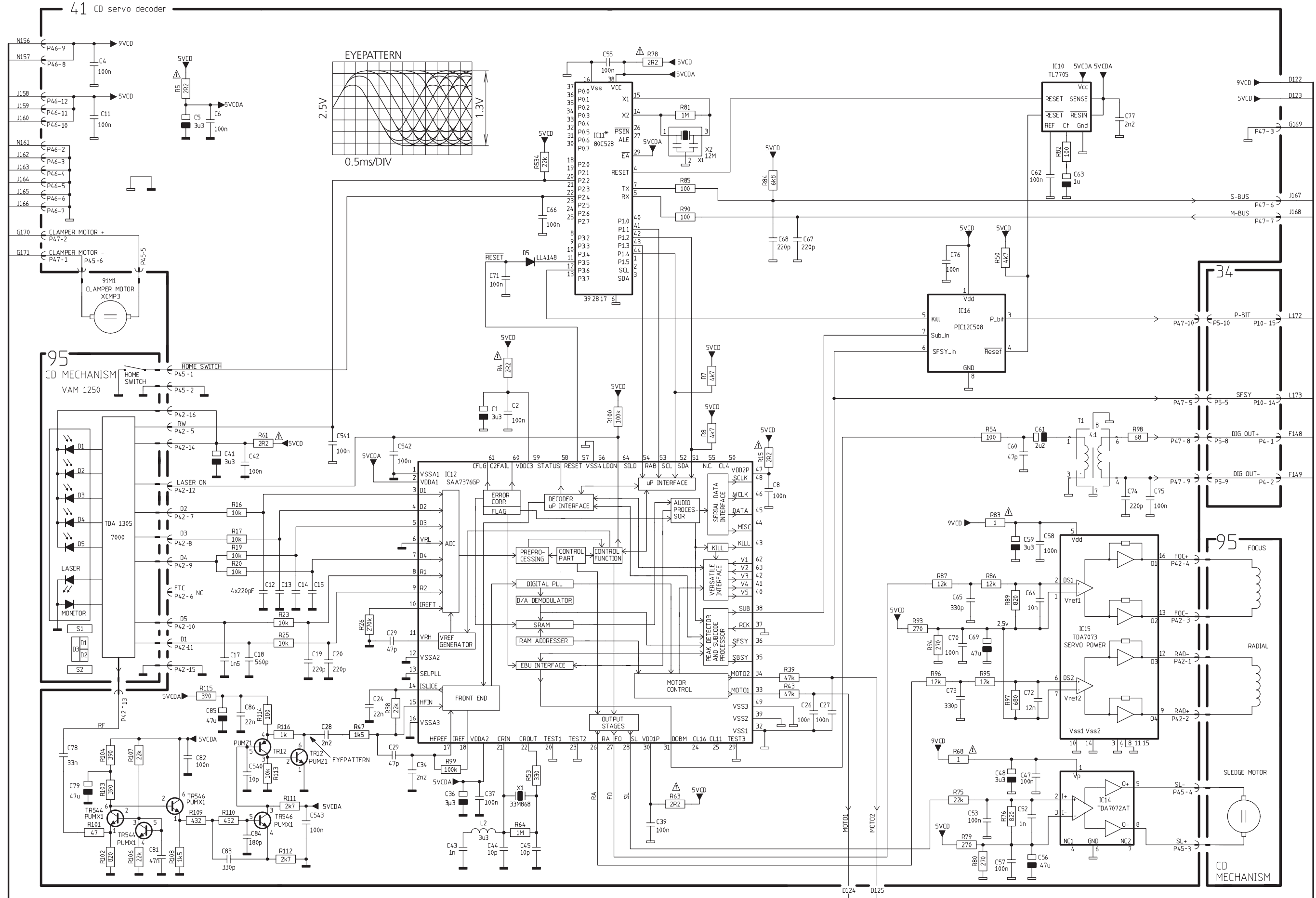
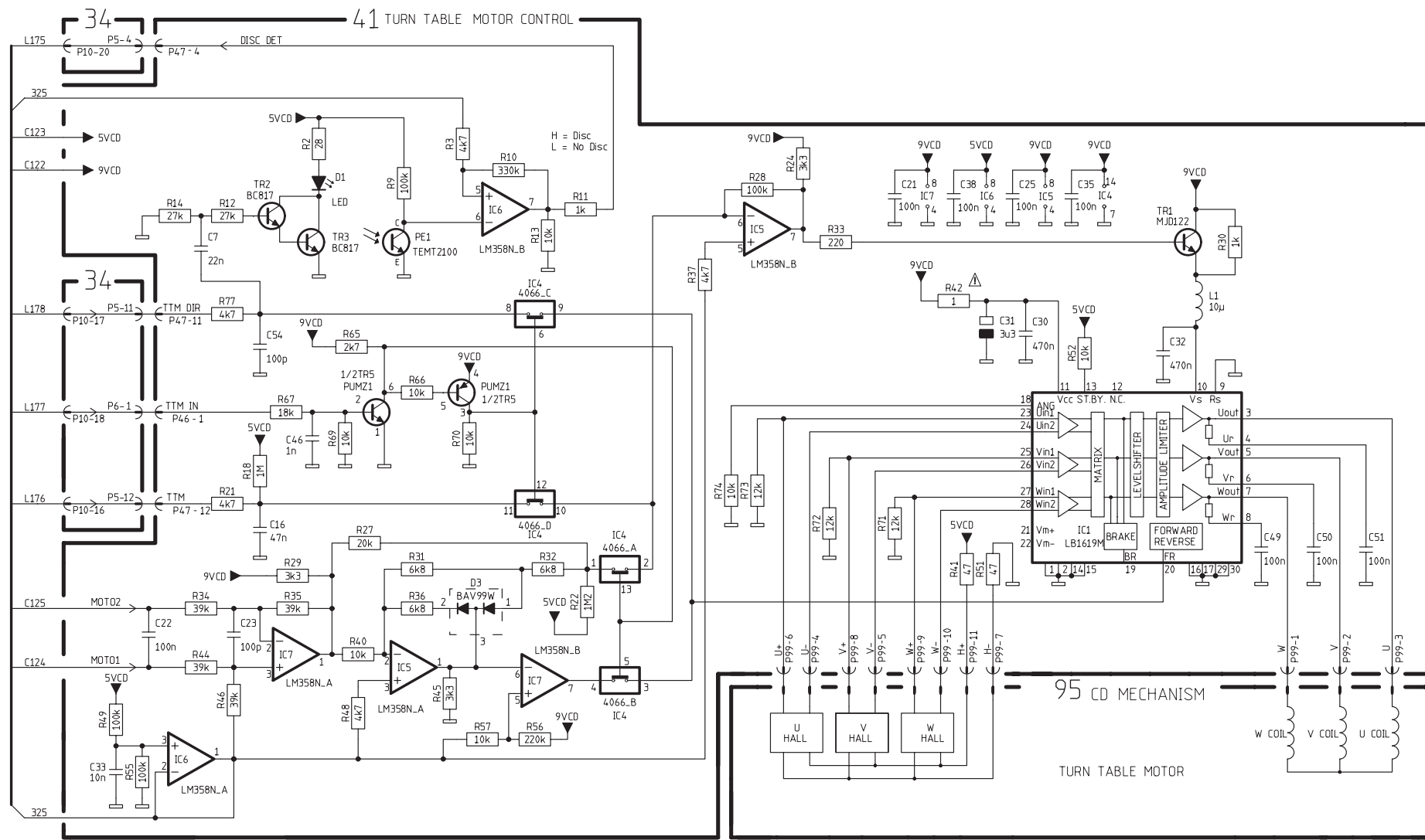
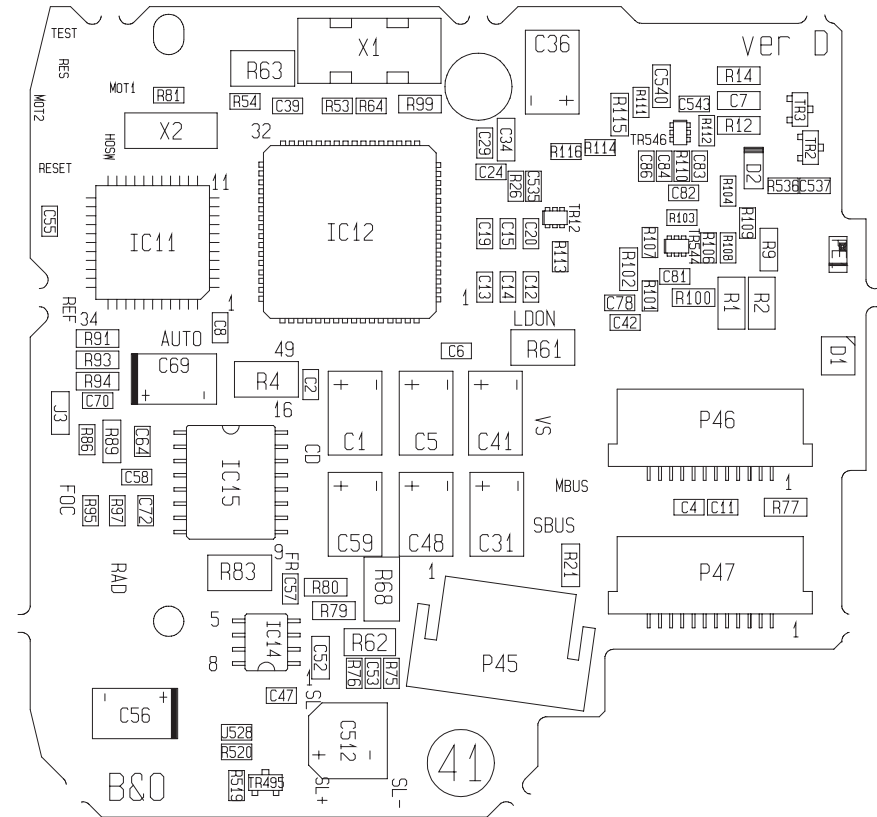

DIAGRAM C - CD servo decoder PCB drawing for PCB41 see page 2.17





PCB41, CD – primary side



PCB41, CD – secondary side

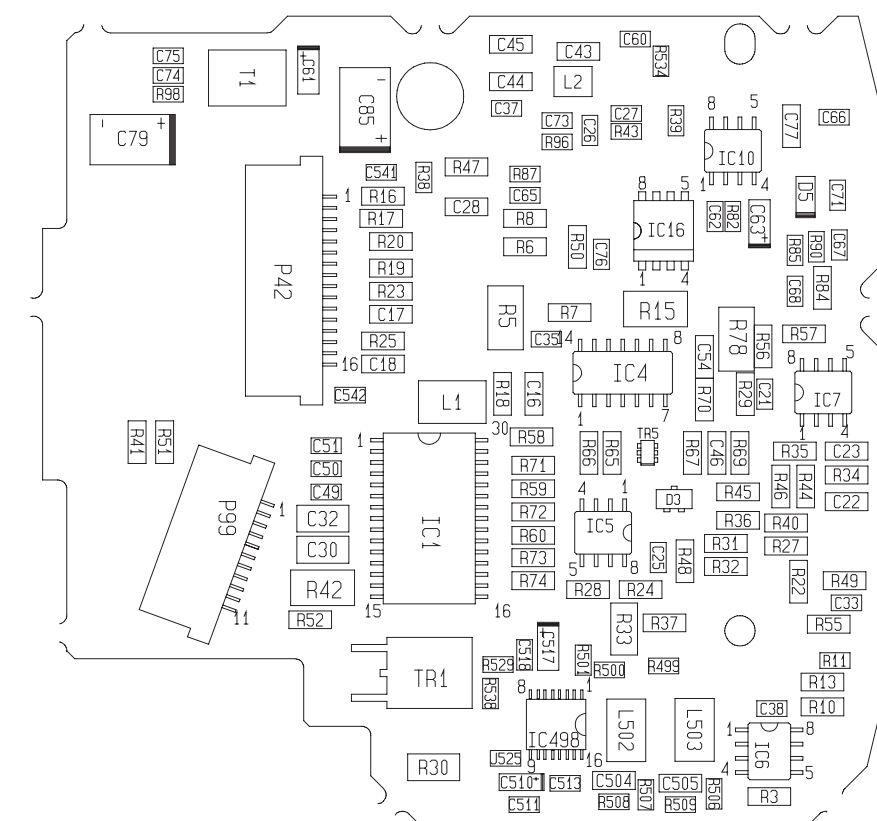
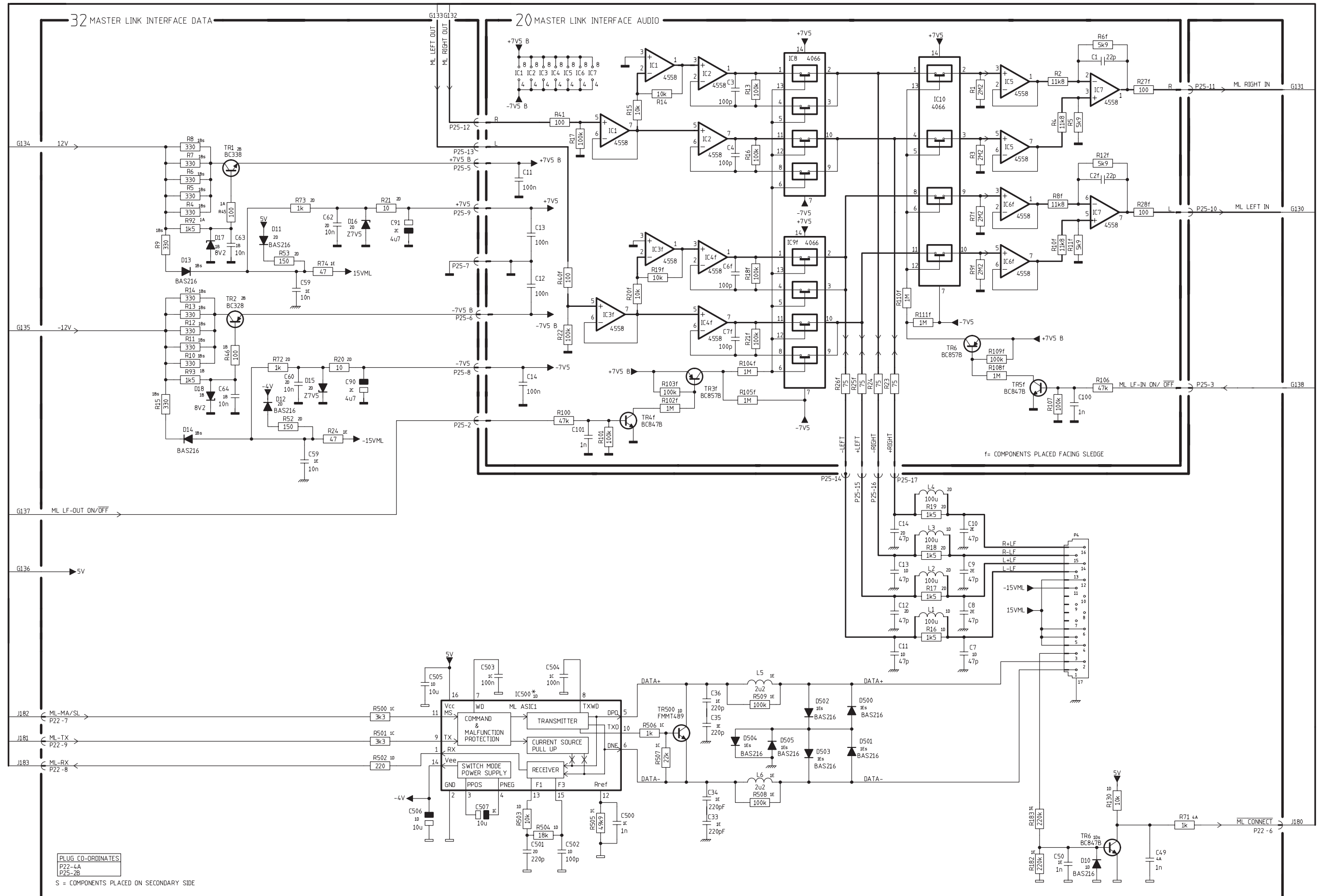

DIAGRAM E – Master Link interface data/audio PCB drawing for PCB32 see page 2.21



PLUG CO-ORDINATES
 P22-4A
 P25-2B

S = COMPONENTS PLACED ON SECONDARY SIDE

f = COMPONENTS PLACED FACING SLEDGE

32 DIGITAL/ANALOG DECODER
From version 0

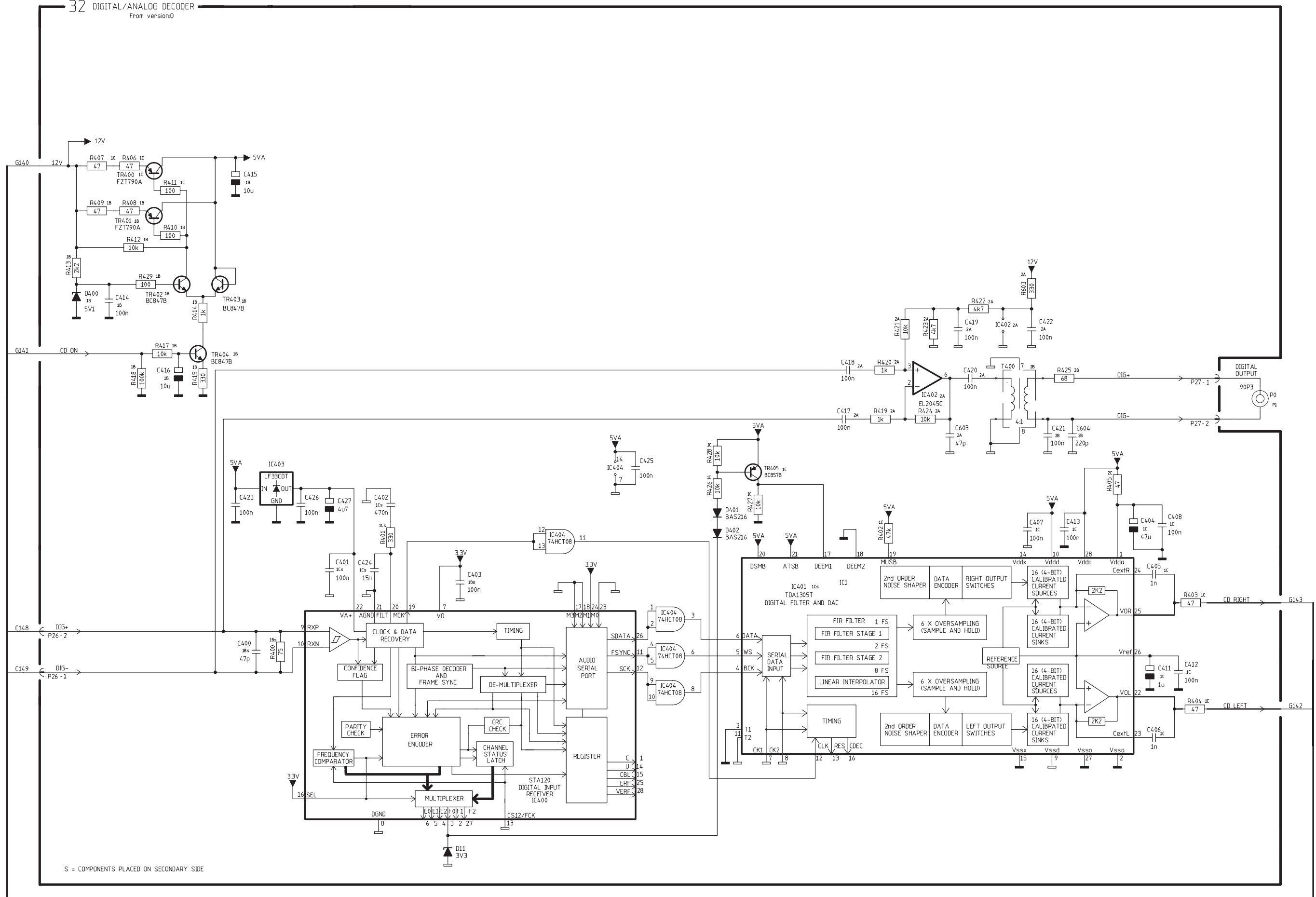

S = COMPONENTS PLACED ON SECONDARY SIDE

DIAGRAM G – Input select and Sound adjustment PCB drawing for PCB21 and PCB32 see page 2.21

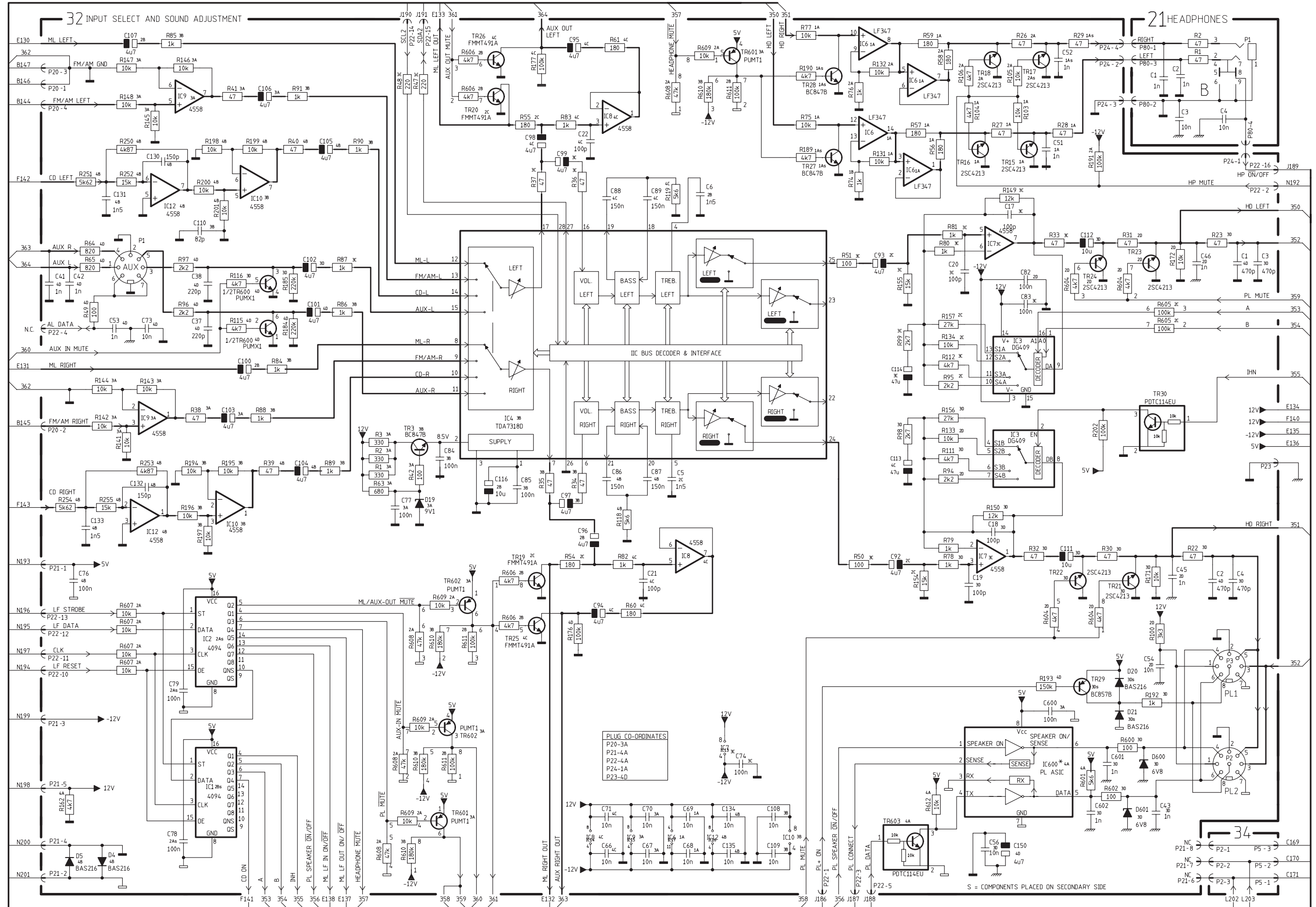

PCB21, Headphone

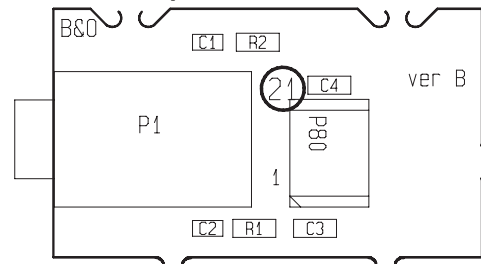

PCB32, Input/output Select, Sound Adjustment – preliminary side



PCB32, Input/output Select, Sound Adjustment – secondary side

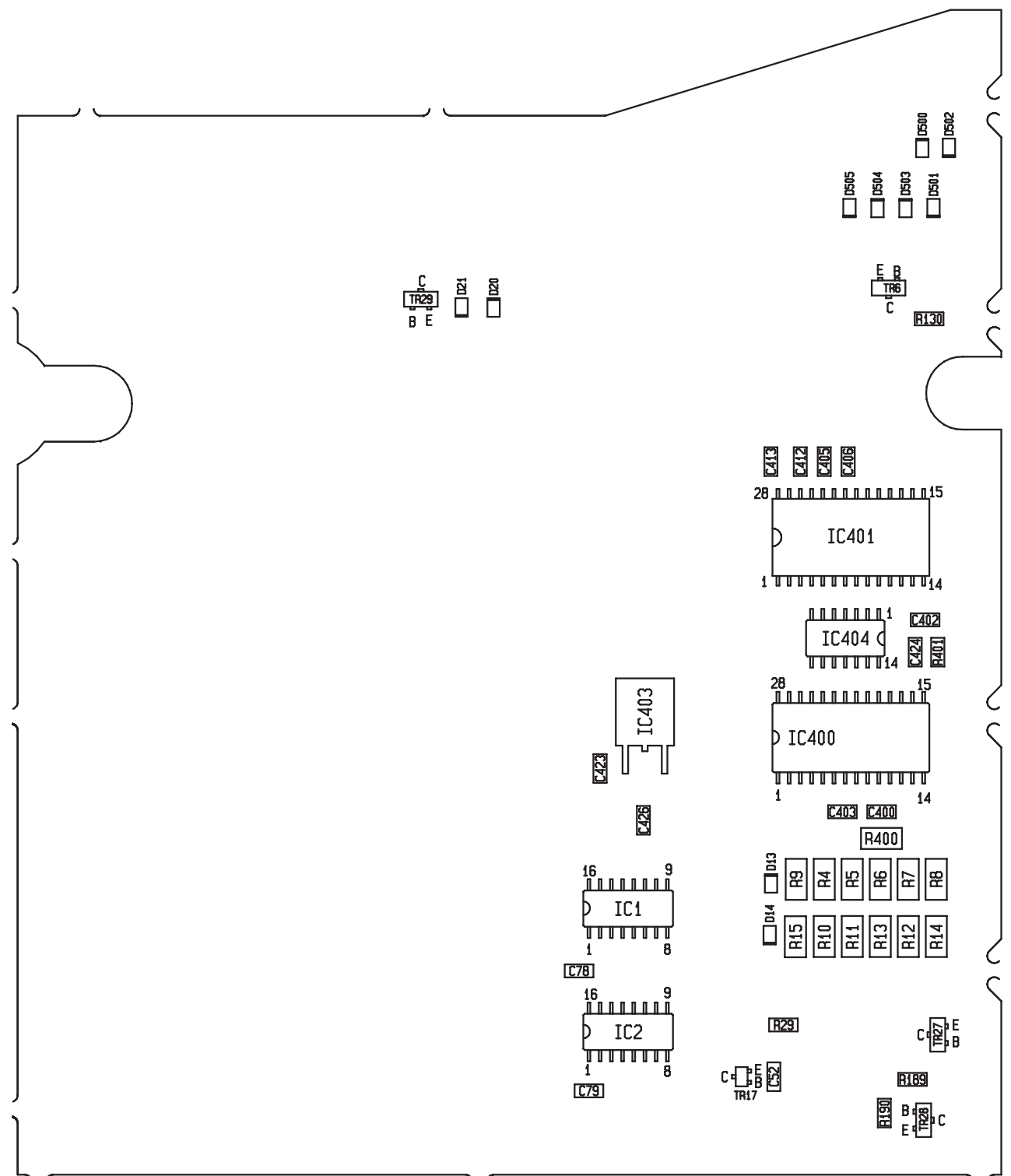
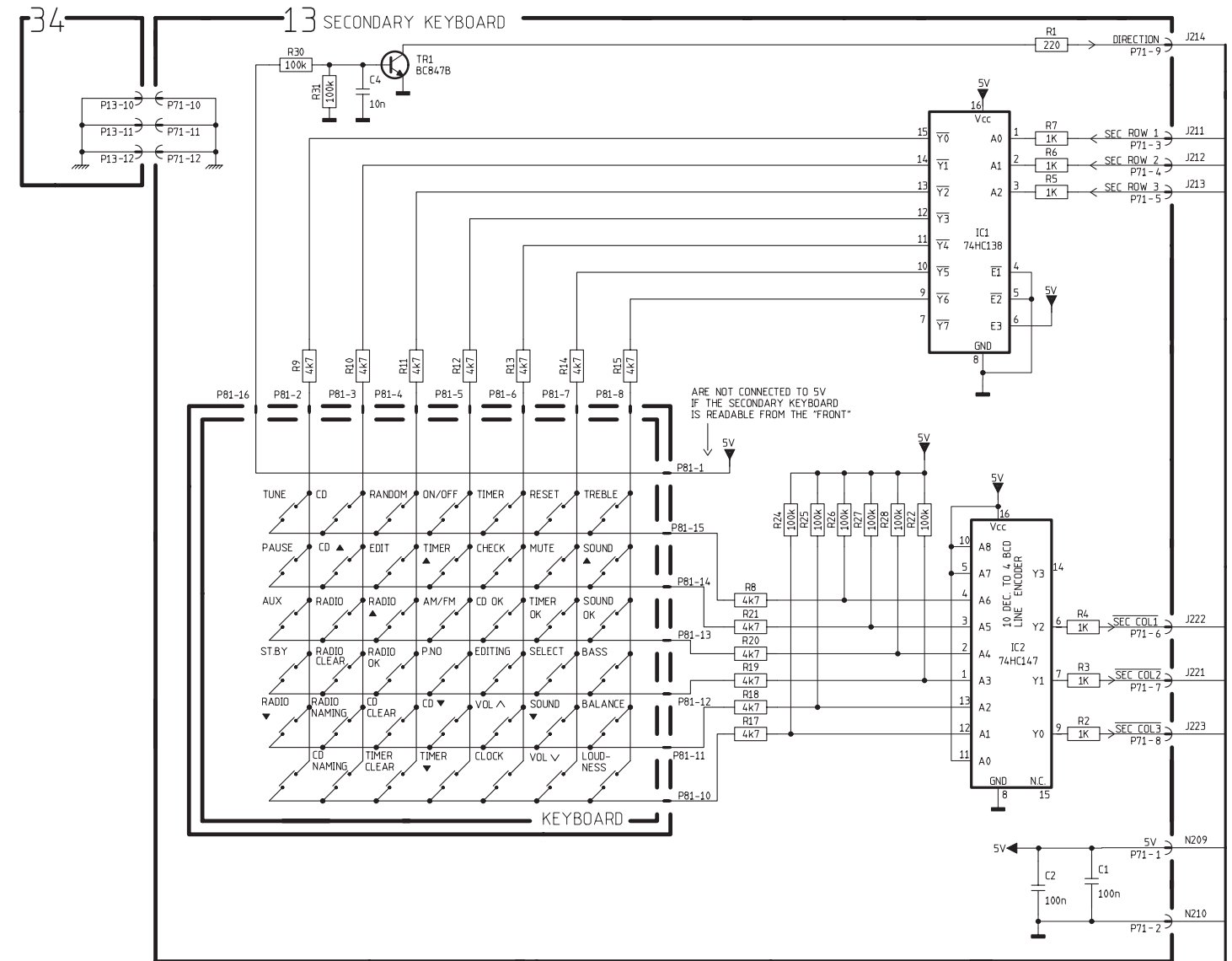
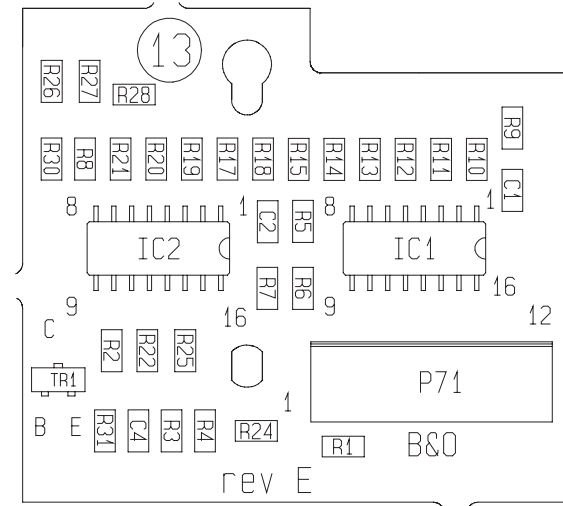

DIAGRAM H – Keyboard and IR Receiver

PCB13, Secondary Keyboard



PCB drawing for PCB14 see page 2.30

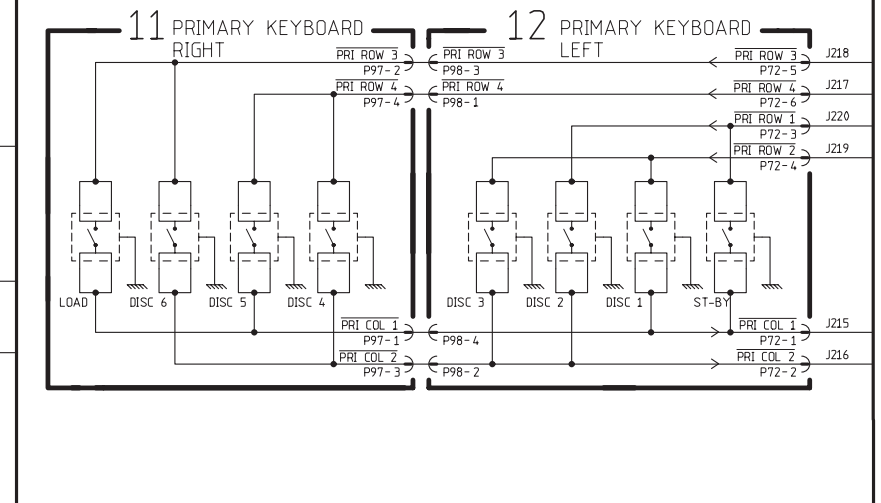
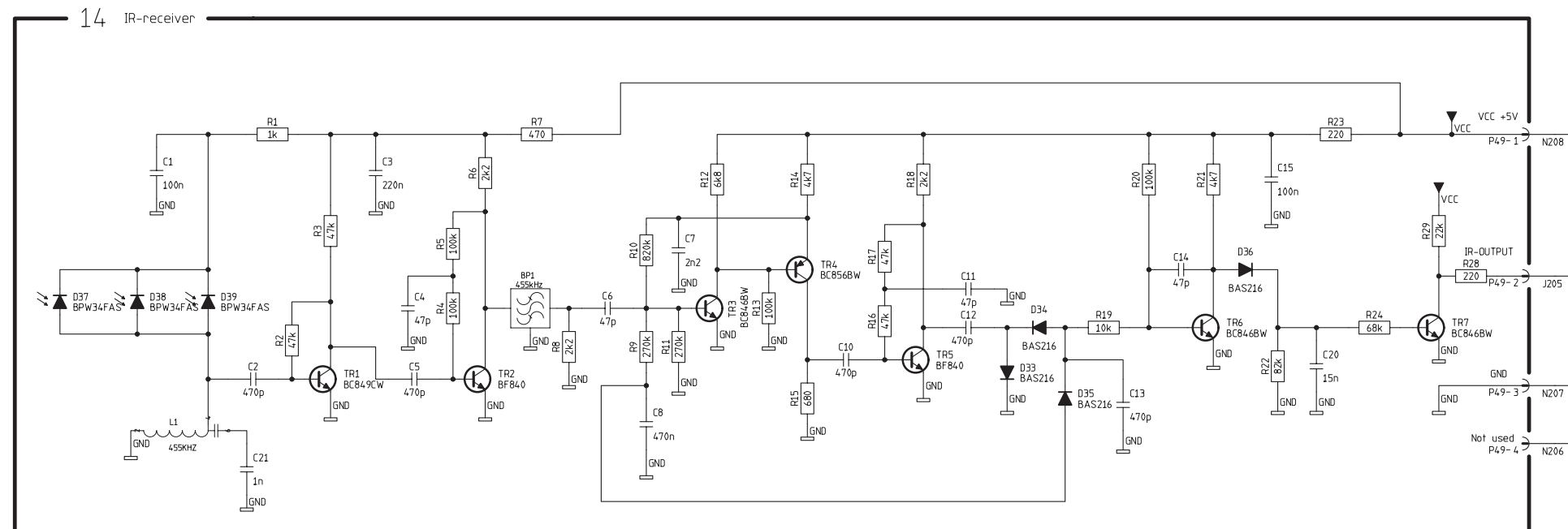
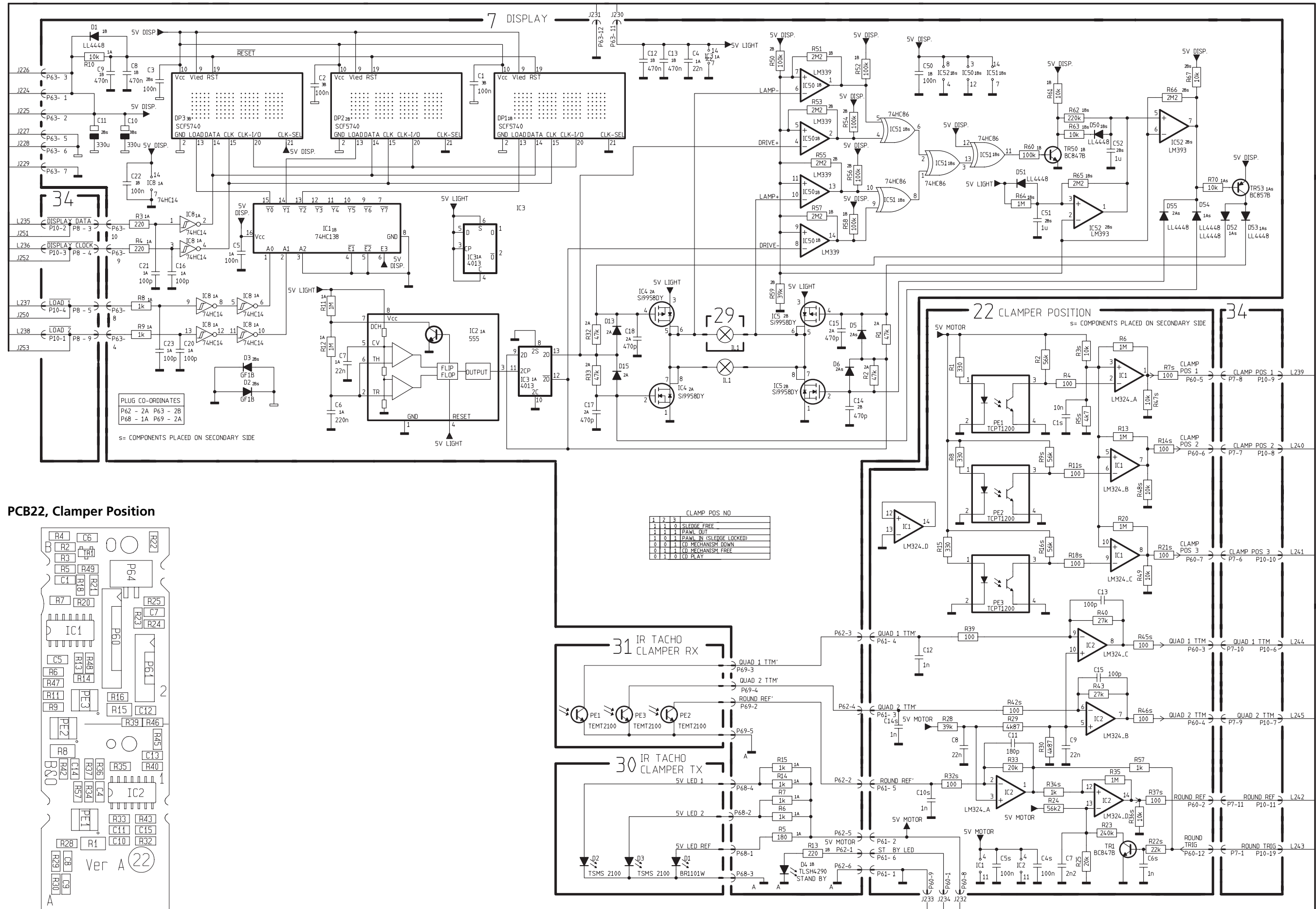

DIAGRAM I – Display and clamber position PCB drawing for PCB7 see page 2.31



PCB22, Clamber Position

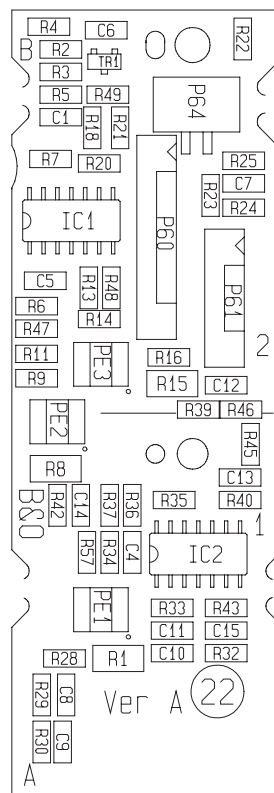
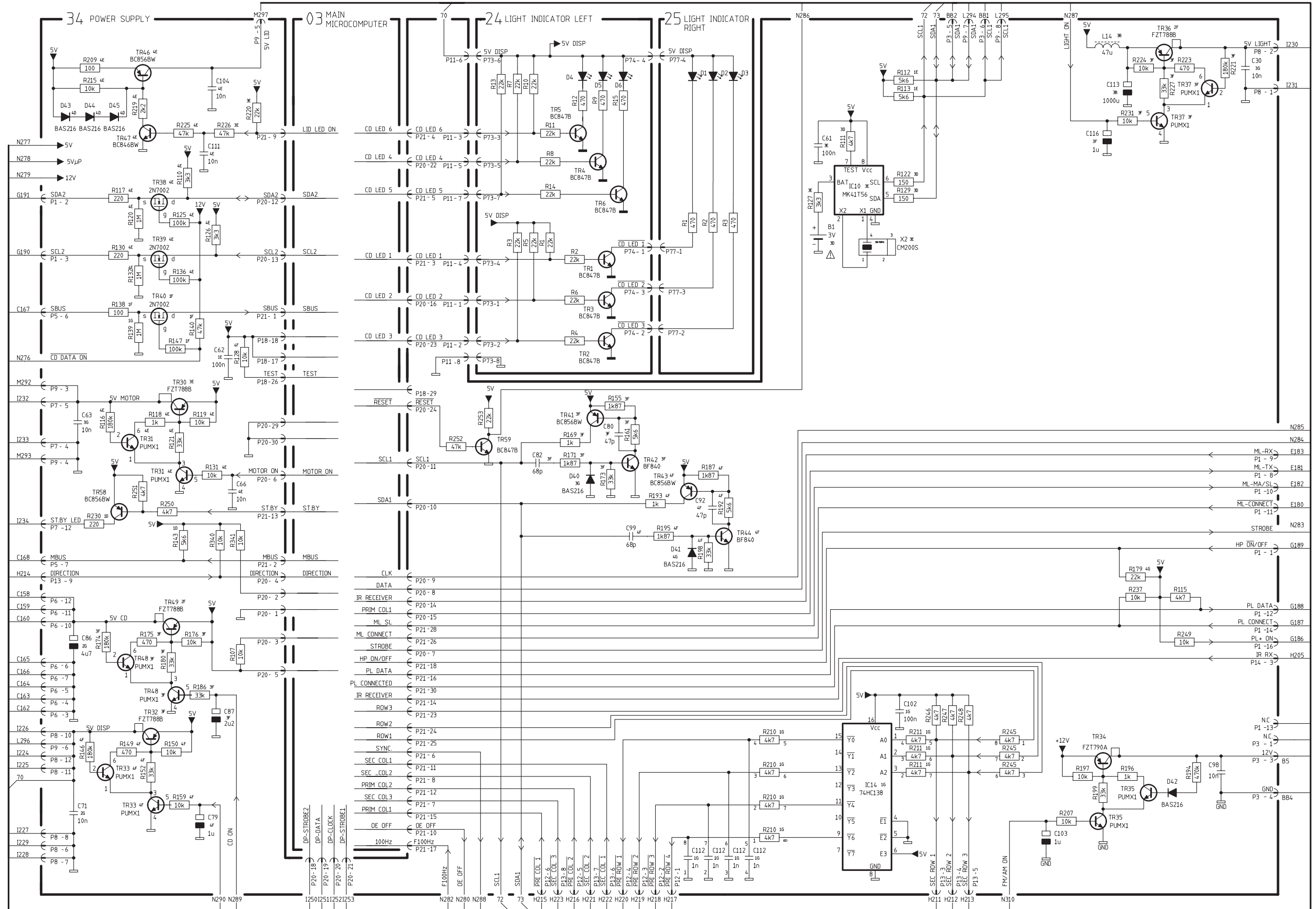

DIAGRAM J – Microcomputer, Power supply & Light Indicator

PCB drawing for PCB24 see page 2.30 – PCB34 see page 2.25



PCB34, Power Supply

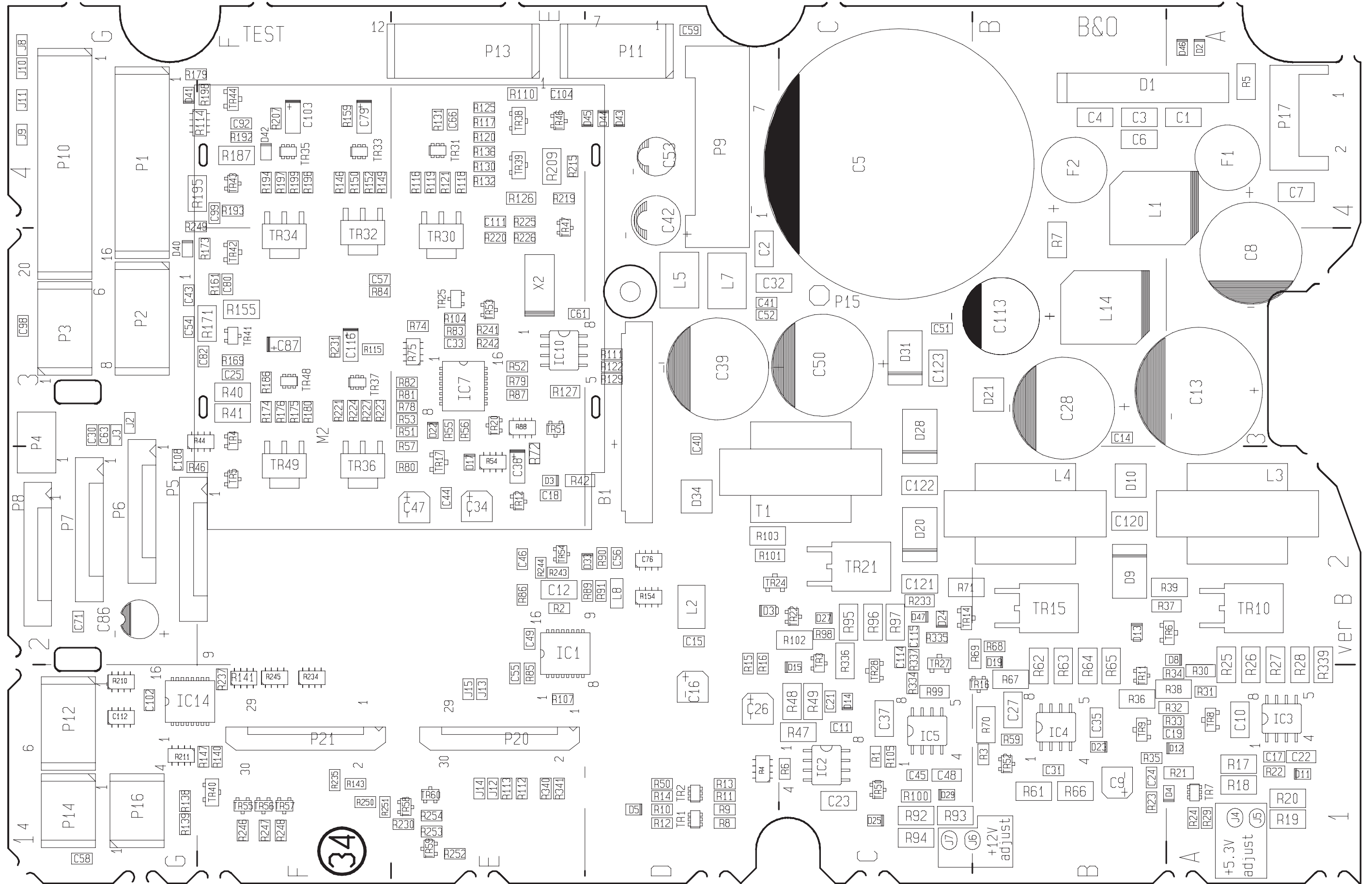
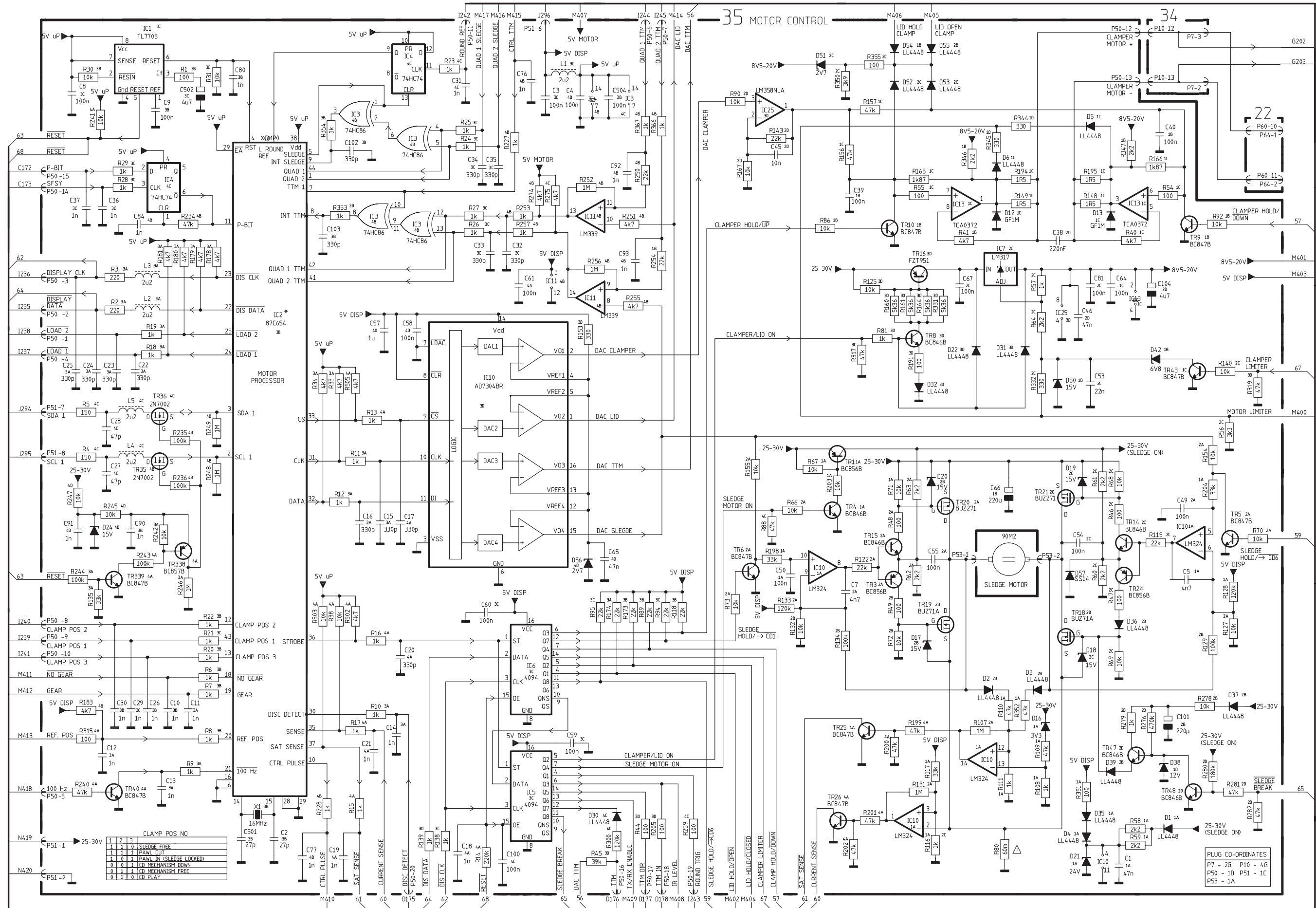
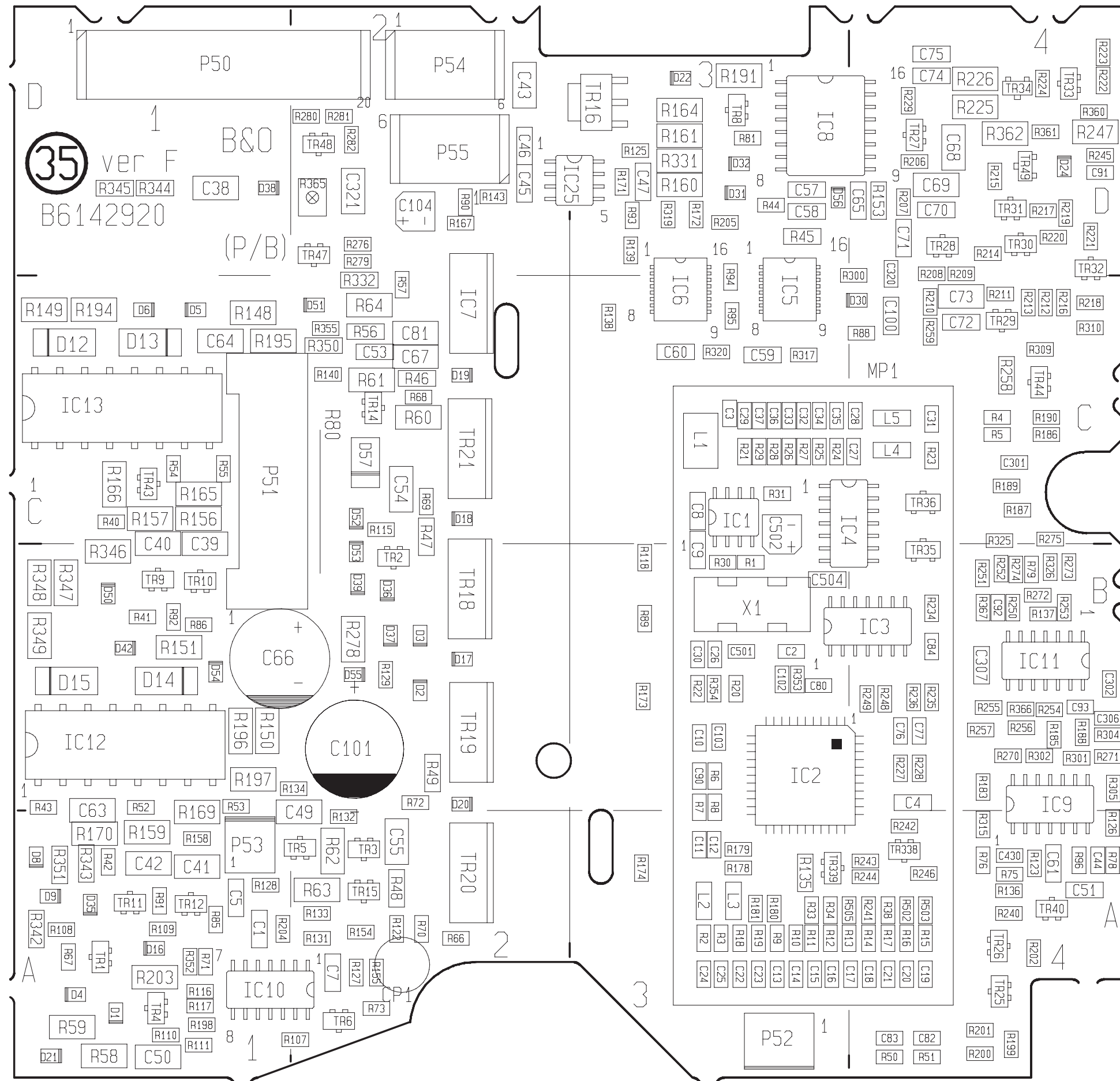

DIAGRAM L - Motor Control



PCB35, Motor Control



35 ver F
B6142920
B&O
(P/B)

PCB9, Sledge Position

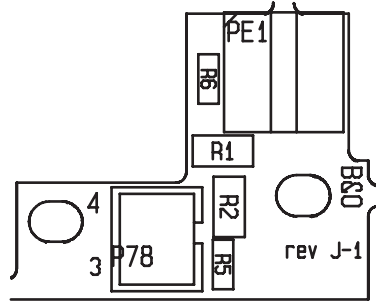

PCB26, End Stop Detector

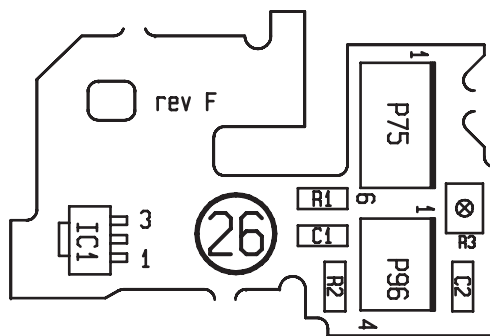

PCB28, Safety RX

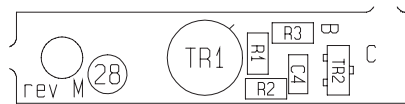

PCB37, Lid Motor

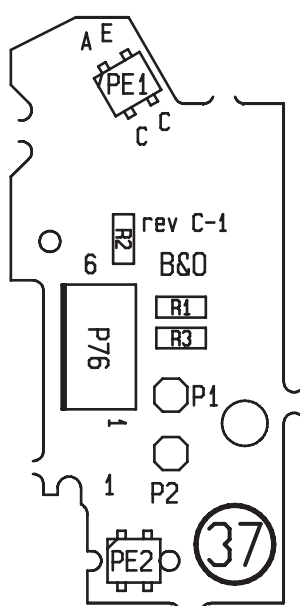

DIAGRAM M – Motor Control and Detection

PCB drawing for PCB35 see page 2.27

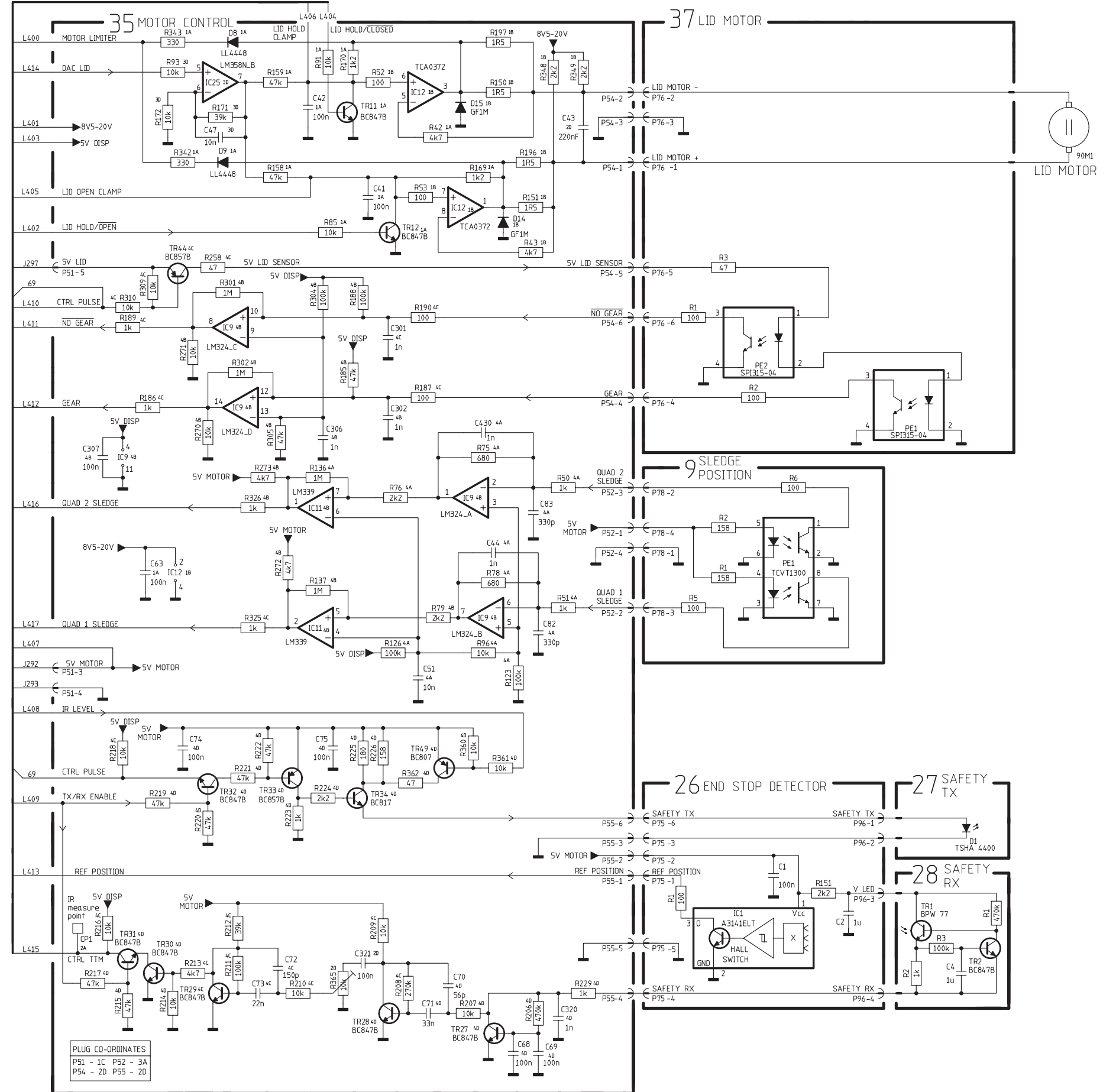

DIAGRAM N – Power Supply PCB drawing for PCB4 see page 2.31 – PCB5 see page 2.30 – PCB34 see page 2.25

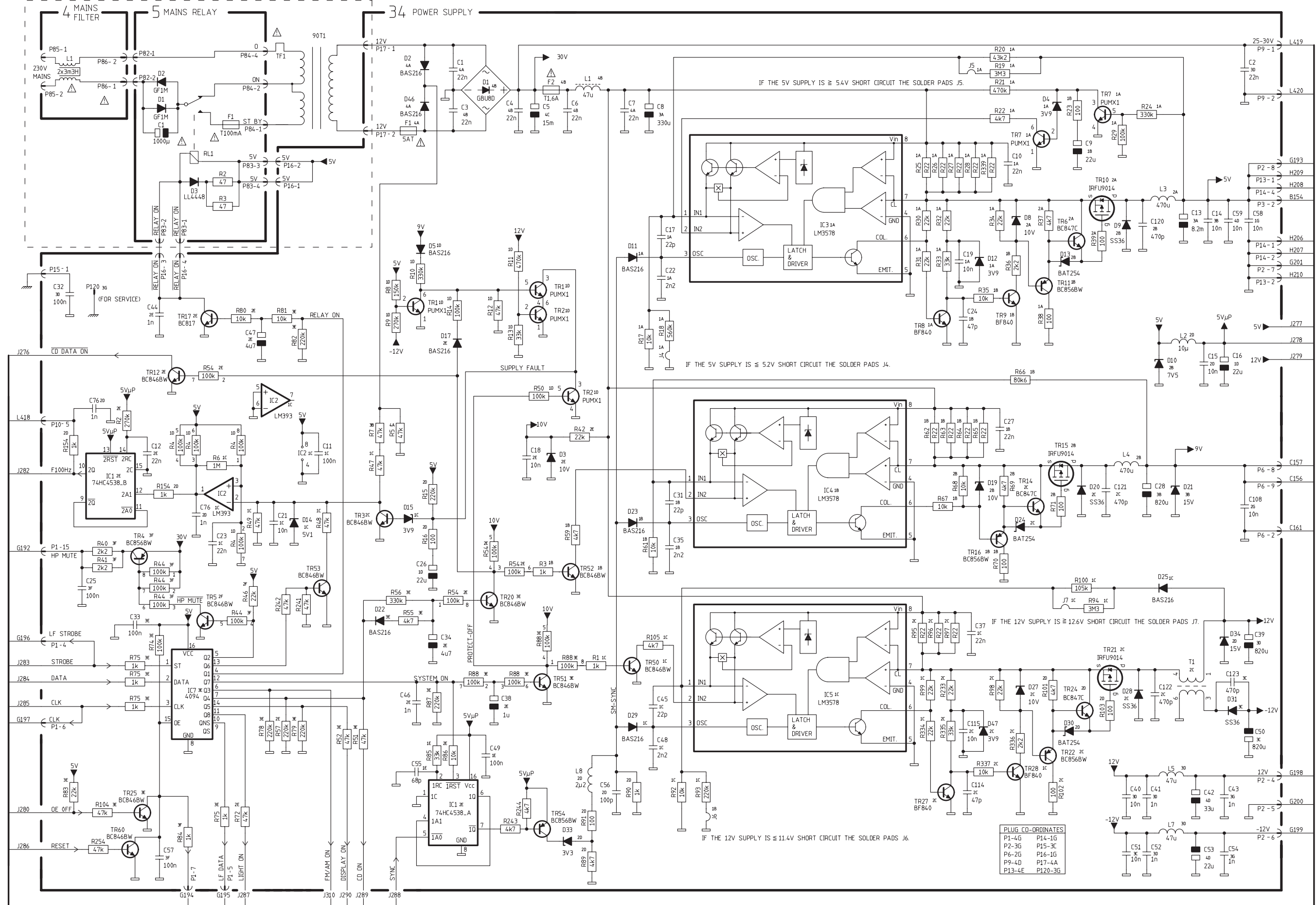
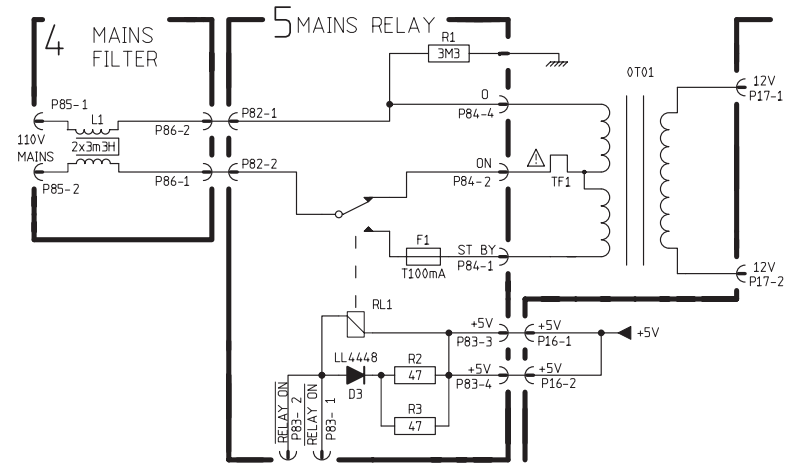
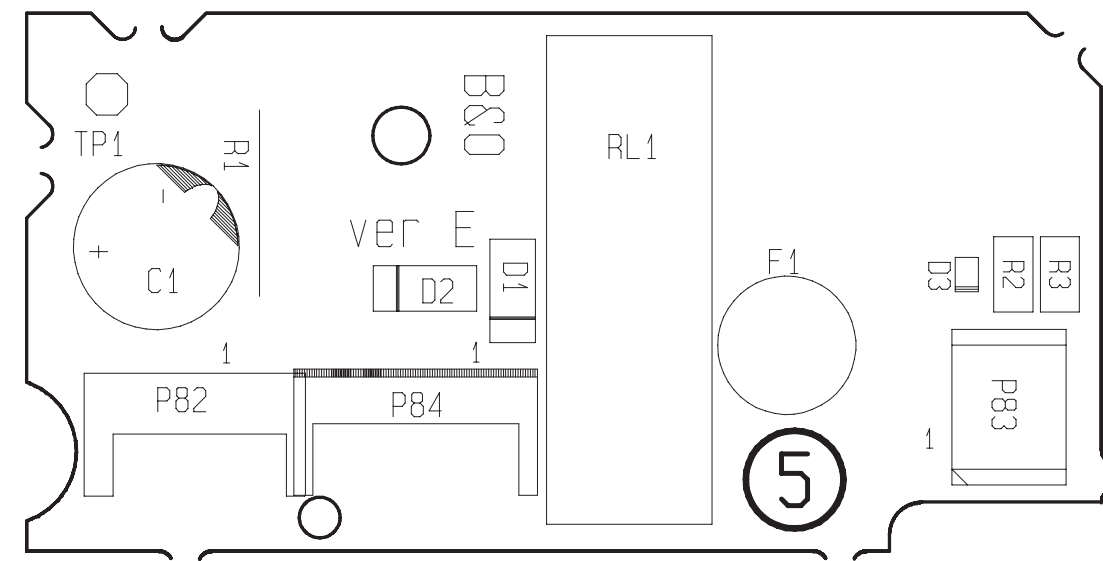

DIAGRAM O – Mains relay USA



PCB5, Mains Relay



PCB14, IR Receiver

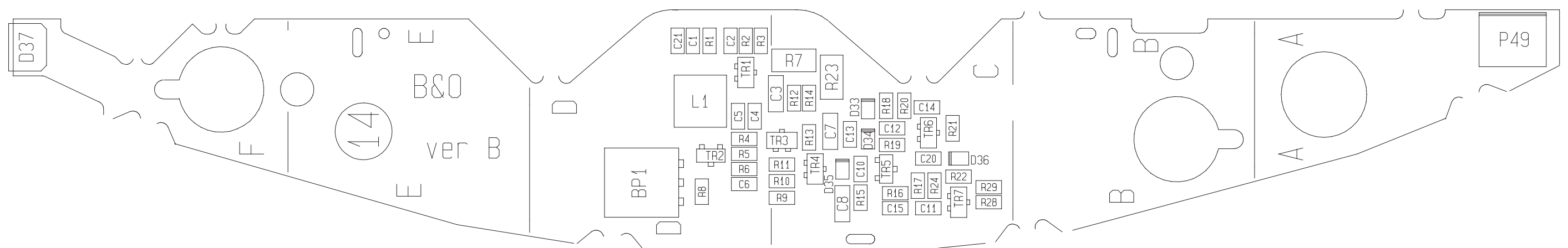

PCB24, Light indication, left

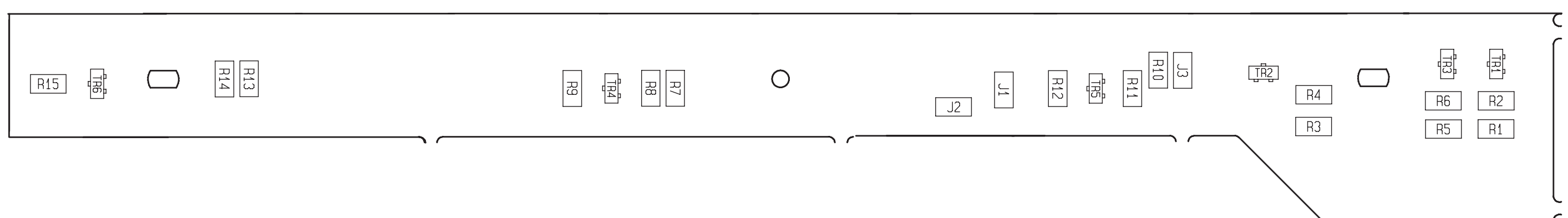

PCB4, Mains Filter

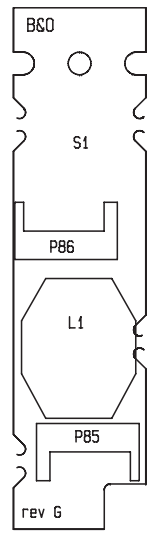

PCB7, Display

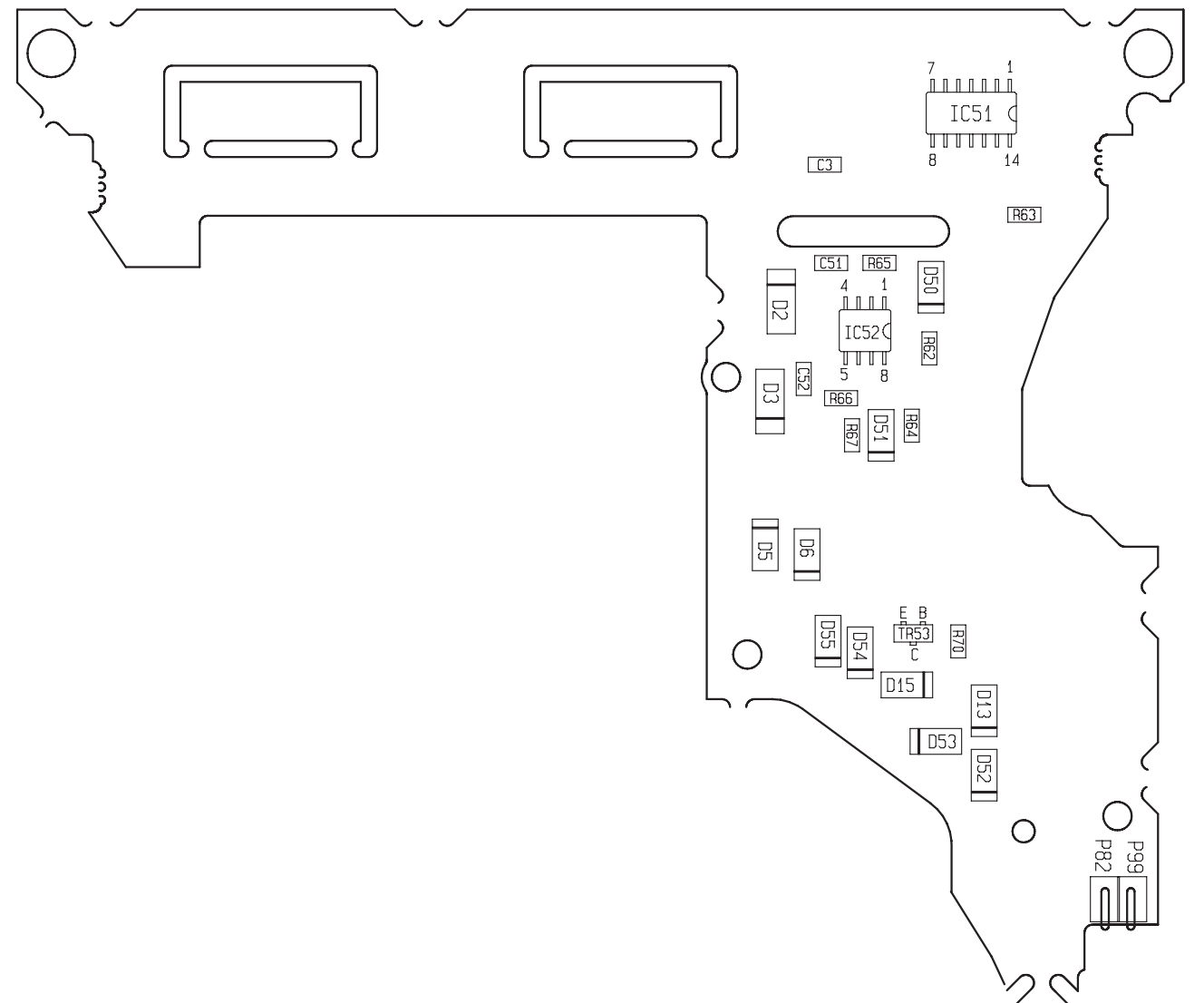
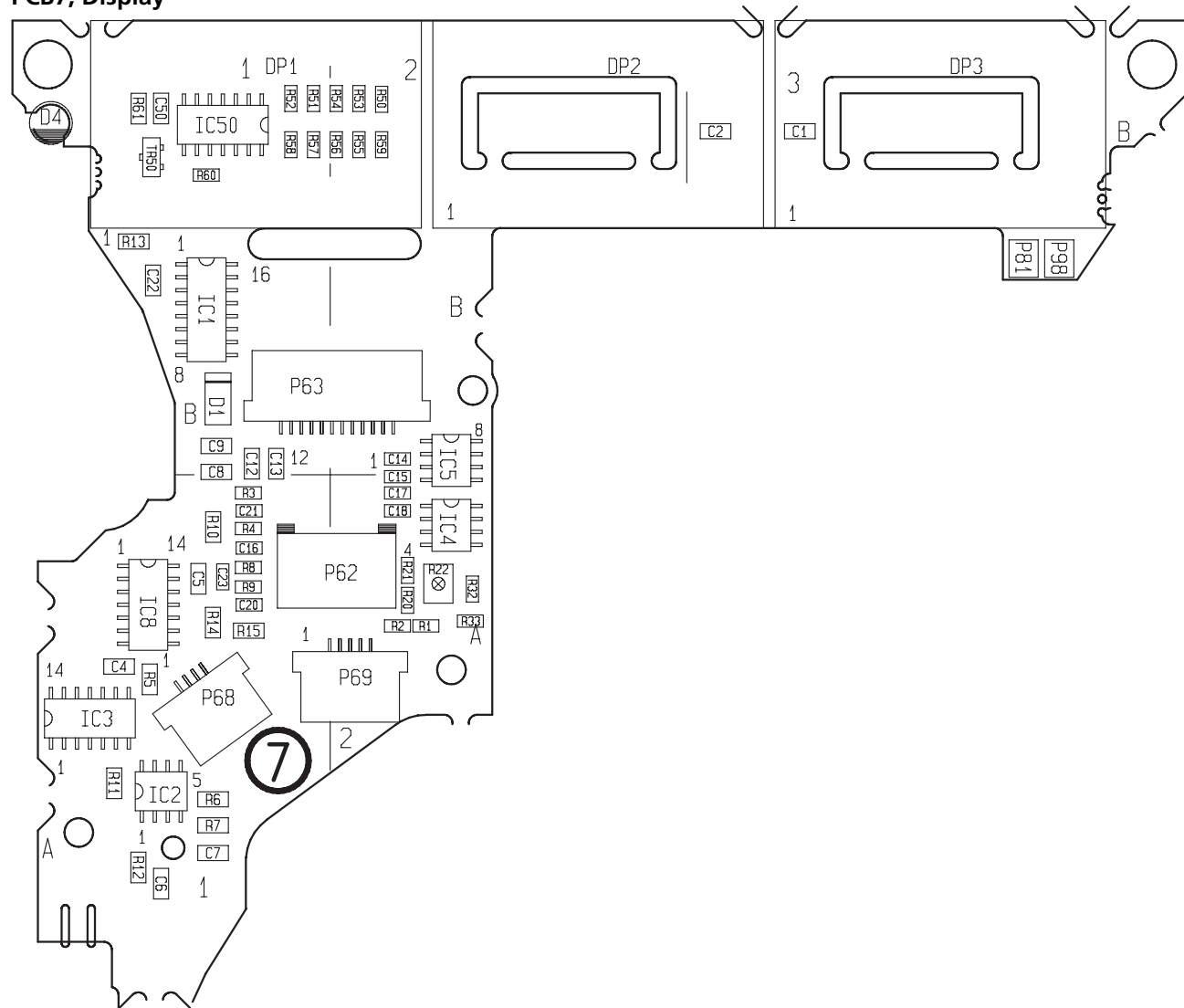

PCB1, 8000535 FM/AM - RDS
Type 2574

C202	4000401	12pF 50V	C274	4001127	22pF 50V
C203	4001125	15pF 50V	C275	4001131	47pF 50V
C213	4001120	5.6pF 50V	C297	4000401	12pF 50V
C221	4001126	18pF			
C222- C223	4001119	4.7pF 50V			

L201	8021385	Coil 108nH
L202- L203	8021384	Coil 108nH
L204	8021350	Coil164nH

Other electrical parts like PCB1, type 2571, 2572, 2573, 2575, 2576, 2577, 2580

PCB3, 8000513 Main Microcomputer

IC3Δ	8343945	147	SW IC
------	---------	-----	-------

PCB4, 8000463 Mains Filter

L1▲	8022318	Coil 2 x 3.3mH
-----	---------	----------------

P85- P86	7221057	Plug 2/3 pole
-------------	---------	---------------

PCB5, 8005661 Mains relay
Type 2571, 2572, 2574, 2575,
2577, 2580

D1- D2	8300915	209	GF 1M
D3	8301045	250	BAS216

C1	4200821	1000μF -20+50% 6.3V
----	---------	---------------------

RL1▲	7600120	Relay 5V
------	---------	----------

F1▲	6600084	Fuse 100mAT 250V
-----	---------	------------------

P82	7221057	Plug 2/3 pole
P83	7211221	Socket 4 pole
P84	7221163	Plug 4/3 pole

PCB5, 8005664 Mains relay
Type 2573, 2576

R1	5000194	3.3MΩ 10% 1/2W
----	---------	----------------

F1▲	6600164	Fuse 100mAT 125V
-----	---------	------------------

Other electrical parts like PCB5, type 2571, 2572, 2574, 2575, 2577, 2580

PCB7, 8005364 Display

IC1Δ	8342095	138	74HC138	IC8Δ	8341277	138	74HC14
IC2Δ	8342270	138	TIMER 555	IC50Δ	8341857	138	LM339
IC3Δ	8340740	138	4013	IC51Δ	8340433	138	74HC86
IC4Δ- IC5Δ	8342681	138	SI9958DY	IC52Δ	8341812	138	LM393

TR50	8320755	51	BC847B	TR53	8320811	51	BC857B
------	---------	----	--------	------	---------	----	--------

D1	8300606	250	LL4448	D13	8300606	250	LL4448
D2-	8300907	256	GF1B	D15	8300606	250	LL4448
D3				D50-	8300606	250	LL4448
D4	8330387	265	Led red	D55			
D5- D6	8300606	250	LL4448				

R59	5013256	39KΩ 1% 1/16W
-----	---------	---------------

C1- C3	4010274-	100nF -20+80% 25V	C10-	4201448	330μF 20% 6.3V
C4	4010272	22nF -20+80% 50V	C11		
C5	4010274	100nF -20+80% 25V	C12-	4010321	470nF -20+80% 16V
C6	4010314	220nF -20+80% 25V	C13		
C7	4010315	22nF 10% 25V	C14-	4001143	470pF 5% 50V
C8- C9	4010321	470nF -20+80% 16V	C15		
			C16	4001135	100pF 5% 50V

▲ symbol of safety component, see page 2.1

Δ indicates that static electricity may
destroy the component

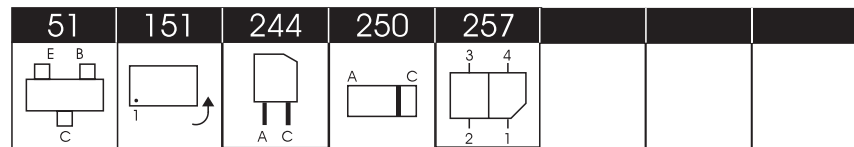

Resistors not referred to are standard, see page 3.13 and 3.14

C17- C18 C20- C21 C22	4001143 4001135 4010274	470pF 5% 50V 100pF 5% 50V 100nF -20+80% 25V	C23 C50 C51- C52	4001135 4010274 4010323	100pF 5% 50V 100nF -20+80% 25V 1µF -20+80% 16V	
IL1	8230125	Bulb, 190mA 6.3V				
P62 P63	7211134 7210893	Socket 6 pole Socket 12 pole	P68 P69	7210889 7211133	Socket 4 pole Socket 5 pole	
PCB9, 8005312 Sledge position	PE1Δ	8330388	TCVT1300			
R1- R2	5011853	158Ω 1% 1/4W				
P78	7211221	Socket 4 pole				
PCB11, 8005295 Main keyboard, right	S1- S4	7400429	Switch 1 pole			
P97	7211136	Socket 4 pole				
PCB12, 8005296 Main keyboard, left	S1- S4	7400429	Switch 1 pole			
P72 P98	7211054 7211136	Socket Socket 4 pole				
PCB13, 8005313 Secondary keyboard	IC1Δ IC2Δ	8342095 8342297	151 74HC138 151 74HC147			
TR1	8320755	51 BC847B				
C1- C2 C4	4010316 4010271	100nF 10% 25V 10nF 10% 50V				
P71	7211057	Socket 12 pole				
PCB14, 8005299 IR Receiver	TR1 TR2 TR3 TR4	8321278 8320740 8321187 8321188	BC849CW 51 BF840 51 BC846BW 51 BC856BW	TR5 TR6- TR7	8320740 8321187	51 BF840 51 BC846BW
D33- D36 D37	8301045 8330145	250 BAS216 244 IR detector 880nm 455KHz	D38- D39	8330393	244 IR detector 880nm BPW34FAS	
R7	5011303	470Ω 5% 1/4W	R23	5021512	220Ω 1% 1/4W	
C1 C2 C3 C4 C5	4011134 4001143 4010334 4001131 4001143	100nF 10% 16V 470pF 5% 50V 220nF 10% 16V 47pF 5% 50V 470pF 5% 50V	C6 C7 C8 C10 C11	4001131 4000442 4010387 4001143 4001131	47pF 5% 50V 2.2nF 5% 50V 470nF 10% 16V 470pF 5% 50V 47pF 5% 50V	

Δ indicates that static electricity may destroy the component

	C12-	4001143	470pF 5% 50V		C15	4011134	100nF 10% 16V
	C13				C20	4011124	15nF 10% 50V
	C14	4001131	47pF 5% 50V		C21	4011110	1nF 10% 50V
	L1	8020744	Coil 455KHz				
	BP1	8030392	Cer. filter 455KHz				
	P49	7211053	Socket 4 pole				
PCB20, 8001824 ML interface	IC1Δ- IC7Δ	8341022	151 4558		IC8Δ- IC10Δ	8341024	151 4066
	TR3	8320811	51 BC857B		TR6	8320811	51 BC857B
	TR4- TR5	8320755	51 BC847B				
	R2	5011841	11.8KΩ 1% 1/8W		R14-	5011557	10KΩ 1% 1/8W
	R4	5011841	11.8KΩ 1% 1/8W		R15		
	R5-	5011531	5.9KΩ 1% 1/8W		R19-	5011557	10KΩ 1% 1/8W
	R6				R20		
	R8	5011841	11.8KΩ 1% 1/8W		R23-	5011571	75Ω 1% 1/8W
	R10	5011841	11.8KΩ 1% 1/8W		R26		
	R11- R12	5011531	5.9KΩ 1% 1/8W				
	C1- C2	4000277	22pF 5% 50V		C11- C14	4010166	100nF -20+80% 50V
	C3- C4	4000241	100pF 5% 50V		C100- C101	4000345	1.0nF 5% 50V
	C6- C7	4000241	100pF 5% 50V				
PCB21, 8005301 Headphone	C1- C2	4011110	1.0nF 10% 50V		C3- C4	4010271	10nF 10% 50V
	P1	7210510	Jack socket		P80	7211221	Socket 4 pole
PCB22, 8000514 Clamper position	IC1- IC2	8341041	151 LM324				
	TR1	8320755	51 BC847B				
	PE1- PE3	8330478	257 Optocoupler				
	R1	5011188	330Ω 5% 1/4W		R25	5012366	20KΩ 1% 1/8W
	R8	5011188	330Ω 5% 1/4W		R28	5012239	39KΩ 1% 1/8W
	R15	5011188	330Ω 5% 1/4W		R29-	5012290	4.87KΩ 1% 1/8W
	R23	5012278	240KΩ 1% 1/8W		R30		
	R24	5012316	56.2KΩ 1% 1/8W		R33	5012366	20KΩ 1% 1/8W
	C1	4010271	10nF 10% 50V		C10	4010237	1nF 10% 50V
	C4-	4010274	100nF -20+80%		C11	4000415	180pF 5% 50V
	C5				C12	4010237	1nF 10% 50V
	C6	4010237	1nF 10% 50V		C13	4000412	100pF 5% 50V
	C7	4010263	2.2nF 10% 50V		C14	4010237	1nF 10% 50V
	C8- C9	4010272	22nF -20+80% 50V		C15	4000412	100pF 5% 50V
	P60	7211234	Socket 12 pole				
	P61	7211340	Socket 6 pole				
	P64	7221272	Plug 2 pole				

Δ indicates that static electricity may destroy the component

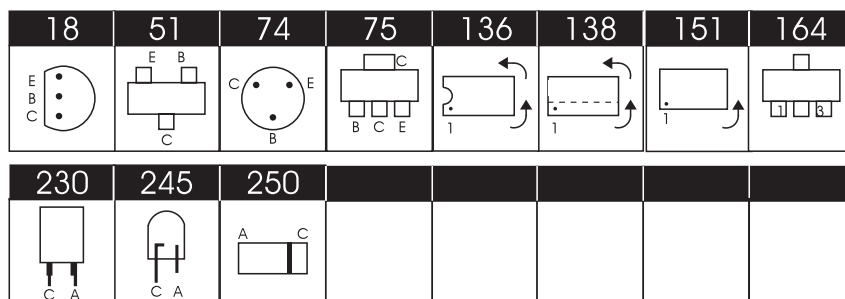

Resistors not referred to are standard, see page 3.13 and 3.14

PCB24, 8005304
Light indication, left

TR1- TR6	8320755	51	BC847B
D4- D6	8330387	230	Led red
P73	6276998	Plug 8 pole	
P74	6276913	Plug 4 pole	

PCB25, 8005305
Light indication, right

D1- D3	8330387	230	Led red
-----------	---------	-----	---------

PCB26, 8005315 End stop detector

IC1Δ	8342715	164	A3141ELT
C1	4010274	100nF -20+80% 25V	
C2	4010323	1μF -20+80% 16V	
P75	7211054	Socket 6 pole	
P96	7211053	Socket 4 pole	

PCB27, 8005377 Safety TX

D1	8330266	245	TSHA4480
----	---------	-----	----------

PCB28, 8005303 Safety RX

TR1	8330363	74	BPW77
TR2	8320755	51	BC847B
C4	4010323	1μF -20+80% 16V	

PCB29, 8005309 Lamp

IL1	8230125	Bulb, 190mA 6.3V	
-----	---------	------------------	--

PCB30, 8001865
IR transmitter, tacho clamper

PCB31, 8001866
IR receiver, tacho clamper

PCB32, 8005399
Input/Output select and sound adj.

IC1Δ-	8341025	138	4094	IC12Δ	8341022	138	4558
IC2Δ				IC400Δ	8342869	151	CS8412
IC3Δ	8341059	138	4052	IC401Δ	8342497	151	TDA1305
IC4Δ	8342238	151	TDA7318D	IC402Δ	8342950	151	EL2045CS
IC6Δ	8340205	151	LF347	IC500Δ*	8342500	151	Asic-ML Data
IC7Δ-	8341022	138	4558	IC600Δ*	8342900	151	Asic-PL Data
IC10Δ							

* specially selected or adapted sample

Δ indicates that static electricity may destroy the component

TR1	8320512	18	BC338-25	TR15-	8320941	51	2SC4213
TR2	8320523	18	BC328-25	TR18	8320941	51	2SC4213
TR3	8320755	51	BC847B	TR19-	8321080	51	FMMT491A
TR6	8320755	51	BC847B	TR26			

TR27- TR28	8320755	51	BC847B	TR405	8320811	51	BC857B
TR29	8320811	51	BC857B	TR500	8321159	51	FMMT489
TR400- TR401	8321171	75	FZT790A	TR600	8321198	136	PUMX1
TR402- TR404	8320755	51	BC847B	TR601- TR602	8321197	136	PUMT1
				TR603	8321202	51	PDTC114EU
D2- D3	8300644	250	Z6.2V 2% 0.5W	D19	8300762	250	Z9.1V 2% 0.5W
D4- D5	8301045	250	BAS216	D20- D21	8301045	250	BAS216
D10- D14	8301045	250	BAS216	D400	8300563	250	Z5.1V 2% 0.5W
D15- D16	8300636	250	Z7.5V 5% 0.5W	D500- D505	8301045	250	BAS216
D17- D18	8300723	250	Z8.2V 2% 0.5W	D600- D601	8300520	250	Z6.8V 5% 0.5W
R141- R148	5012331	10K Ω	1% 1/10W	R505	5011599	49.9K Ω	1% 1/8W
R194- R201	5012331	10K Ω	1% 1/10W	R600	5021484	100 Ω	1% 1/4W
R250	5012290	4.87K Ω	1% 1/10W	R602	5021484	100 Ω	1% 1/4W
R251	5012297	5.62K Ω	1% 1/10W	R604	5030052	4 x 4.7K Ω	5% 1/16W
R253	5012290	4.87K Ω	1% 1/10W	R605	5030054	4 x 100K Ω	5% 1/16W
R254	5012297	5.62K Ω	1% 1/10W	R606	5030052	4 x 4.7K Ω	5% 1/16W
R400	5021391	75 Ω	1% 1/4W	R607	5030050	4 x 10K Ω	5% 1/16W
R406- R409	5021524	47 Ω	1% 1/4W	R608	5030053	4 x 47K Ω	5% 1/16W
R425	5013223	68 Ω	1% 1/16W	R609	5030050	4 x 10K Ω	5% 1/16W
				R610	5030055	4 x 180K Ω	5% 1/16W
				R611	5030054	4 x 100K Ω	5% 1/16W
C1- C4	4000420	470pF	5% 50V	C113- C114	4201164	47 μ F	20% 10V
C5- C6	4000351	1.5nF	5% 50V	C116	4201391	10 μ F	20% 50V
C7- C14	4000408	47pF	5% 50V	C130	4000414	150pF	5% 50V
C17- C22	4000412	100pF	5% 50V	C131	4000457	1.5nF	5% 50V
C33- C38	4000416	220pF	5% 50V	C132	4000414	150pF	5% 50V
C41- C42	4000424	1nF	5% 50V	C133	4000457	1.5nF	5% 50V
C43	4010237	1.0nF	10% 50V	C134- C135	4010271	10nF	10% 50V
C45- C46	4000424	1nF	5% 50V	C150	4200972	4.7 μ F	20% 10V
C49- C50	4010237	1.0nF	10% 50V	C400	4000408	47pF	5% 50V
C51- C52	4000424	1nF	5% 50V	C401	4010274	100nF	-20+80% 25V
C53	4010237	1.0nF	10% 50V	C402	4010273	47nF	-20+80% 50V
C54	4010271	10nF	10% 50V	C403	4010274	100nF	-20+80% 25V
C56	4010271	10nF	10% 50V	C404	4201164	47 μ F	20% 10V
C59- C64	4010271	10nF	10% 50V	C405- C406	4000424	1nF	5% 50V
C66- C71	4010271	10nF	10% 50V	C407- C408	4010274	100nF	-20+80% 25V
C73	4010271	10nF	10% 50V	C411	4201348	1 μ F	10% 16V
C74- C79	4010274	100nF	-20+80% 25V	C412- C414	4010274	100nF	-20+80% 25V
C82- C85	4010274	100nF	-20+80% 25V	C415- C416	4201163	10 μ F	20% 35V
C86- C89	4130307	150nF	10% 63V	C417- C422	4010274	100nF	-20+80% 25V
C90- C107	4200916	4.7 μ F	20% 25V	C500	4010237	1.0nF	10% 50V
C108- C109	4010271	10nF	10% 50V	C501	4000416	220pF	5% 50V
C110	4000281	82pF	5% 50V	C502	4000412	100pF	5% 50V
C111- C112	4201163	10 μ F	20% 35V	C503	4010316	100nF	10% 25V
				C504	4010274	100nF	-20+80% 25V
				C505- C507	4201163	10 μ F	20% 35V
				C600	4010274	100nF	-20+80% 25V
				C601- C602	4010132	1.0nF	10% 50V
				C603	4000408	47pF	5% 50V
				C604	4000416	220pF	5% 50V

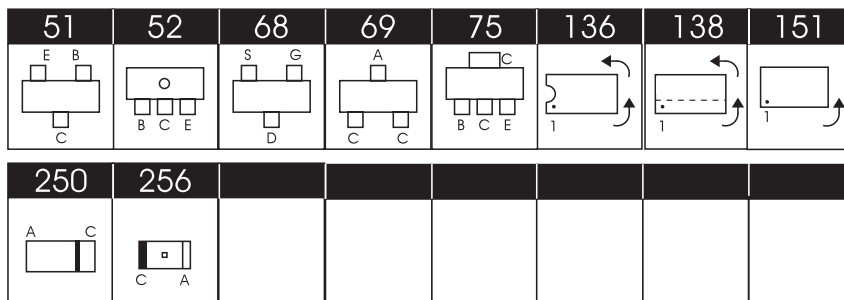

Resistors not referred to are standard, see page 3.13 and 3.14

L1- L4	8020705	Coil 100µH 10%	L5- L6	8020821	Coil 2.2µH 5%
T400	8021159	Transformer 796KHz			
P1	7210418	Socket 7 pole	P22	7211227	Socket 16 pole
P2-	7210689	Socket 8 pole	P23	7500296	Contact pin
P3			P24	7211221	Socket 4 pole
P4	7210904	Socket 16 pole	P26	7221272	Plug 2/2 pole
P20	7211221	Socket 4 pole	P27	7221181	Plug 2 pole
P21	7211223	Socket 8 pole			

PCB34, 8000512

Power Supply

Type 2571, 2572, 2574, 2575, 2577, 2580

IC1Δ	8343327	138	74HC4538	IC7Δ	8343333	138	4094B
IC2Δ	8341812	138	LM393	IC10Δ	8342397	138	M41T56M6
IC3Δ- IC5Δ	8342673	151	LM3578	IC14Δ	8343330	138	74HC138

TR1-	8321198	136	PUMX1	TR32	8321193	75	FZT788B
TR2				TR33	8321198	136	PUMX1
TR3	8321187	51	BC846BW	TR34	8321171	52	FZT790A
TR4	8321188	51	BC856BW	TR35	8321198	136	PUMX1
TR5	8321187	51	BC846BW	TR36	8321193	75	FZT788B
TR6	8320936	51	BC847C	TR37	8321198	136	PUMX1
TR7	8321198	136	PUMX1	TR38-	8320856	68	2N7002
TR8-	8320740	51	BF840	TR40			
TR9				TR41	8321188	51	BC856BW
TR10	8321363	69	STD10PF06	TR42	8320740	51	BF840
TR11	8321188	51	BC856BW	TR43	8321188	51	BC856BW
TR12	8321187	51	BC846BW	TR44	8320740	51	BF840
TR14	8320936	51	BC847C	TR46	8321188	51	BC856BW
TR15	8321363	69	STD10PF06	TR47	8321187	51	BC846BW
TR16	8321188	51	BC856BW	TR48	8321198	136	PUMX1
TR17	8320752	51	BC817-40	TR49	8321193	75	FZT788B
TR20	8321187	51	BC846BW	TR50-	8321187	51	BC846BW
TR21	8321363	69	STD10PF06	TR53			
TR22	8321188	51	BC856BW	TR54	8321188	51	BC856BW
TR24	8320936	51	BC847C	TR55-	8321187	51	BC846BW
TR25	8321187	51	BC846BW	TR57			
TR27-	8320740	51	BF840	TR58	8321188	51	BC856BW
TR28				TR59-	8321187	51	BC846BW
TR30	8321193	75	FZT788B	TR60			
TR31	8321198	136	PUMX1				

D1	8300949		Bridge	D15	8301061	256	Z3.9V 2% 0.4W
D2	8301045	250	BAS216	D17	8301045	250	BAS216
D3	8301072	256	Z10V 2% 0.4W	D19	8301072	256	Z10V 2% 0.4W
D4	8301061	256	Z3.9V 2% 0.4W	D20	8301217	250	STPS3L60S
D5	8301045	250	BAS216	D21	8301104	250	SM6T15C
D8	8301072	256	Z10V 2% 0.4W	D22-	8301045	250	BAS216
D9	8301217	250	STPS3L60S	D23			
D10	8301103	250	SM6T7V5CA	D24	8301218	256	BAT254
D11	8301045	250	BAS216	D25	8301045	250	BAS216
D12	8301061	256	Z3.9V 2% 0.4W	D27	8301072	256	Z10V 2% 0.4W
D13	8301218	256	BAT254	D28	8301217	250	STPS3L60S
D14	8301064	256	Z5.1V 2% 0.4W	D29	8301045	250	BAS216

Δ indicates that static electricity may destroy the component

D30	8301218	256	BAT254	D40-	8301045	250	BAS216
D31	8301217	250	STPS3L60S	D46			
D33	8301059	256	Z3.3V 2% 0.4W	D47	8301061	256	Z3.9V 2% 0.4W
D34	8301104	250	SM6T15C				
R4	5030054	4 x 100K Ω 5% 1/16W		R92	5012382	10K Ω 0.1% 1/4W	
R5	5021508	47K Ω 1% 1/4W		R93	5012169	220K Ω 1% 1/4W	
R7	5021508	47K Ω 1% 1/4W		R94	5023032	3.3M Ω 1% 1/4W	
R17	5012382	10K Ω 0.1% 1/4W		R95-	5021542	0.22 Ω 5% 1/4W	
R18	5023035	560K Ω 1% 1/4W		R97			
R19	5023052	470K Ω 1% 1/4W		R100	5013172	105K Ω 1% 1/8W	
R20	5012175	43.2K Ω 1% 1/4W		R102-	5021484	100 Ω 1% 1/4W	
R25-	5021542	0.22 Ω 5% 1/4W		R103			
R28				R114	5030052	4 x 4.7K Ω 5% 1/16W	
R36	5012200	2.2K Ω 1% 1/4W		R141	5030052	4 x 4.7K Ω 5% 1/16W	
R38-	5021484	100 Ω 1% 1/4W		R143	5013247	6.8K Ω 1% 1/16W	
R39				R146	5013264	180K Ω 1% 1/16W	
R40-	5012200	2.2K Ω 1% 1/4W		R154	5030051	4 x 1K Ω 5% 1/16W	
R41				R155	5012209	1.87K Ω 1% 1/4W	
R44	5030054	4 x 100K Ω 5% 1/16W		R161	5013246	5.6K Ω 1% 1/16W	
R47-	5021508	47K Ω 1% 1/4W		R171	5012209	1.87K Ω 1% 1/4W	
R49				R187	5012209	1.87K Ω 1% 1/4W	
R54	5030054	4 x 100K Ω 5% 1/16W		R192	5013246	5.6K Ω 1% 1/16W	
R61	5012382	10K Ω 0.1% 1/4W		R195	5012209	1.87K Ω 1% 1/4W	
R62-	5021542	0.22 Ω 5% 1/4W		R209	5021484	100 Ω 1% 1/4W	
R65				R210-	5030052	4 x 4.7K Ω 5% 1/16W	
R66	5011843	80.6K Ω 1% 1/4W		R211			
R67	5021225	10K Ω 1% 1/4W		R234	5030053	4 x 47K Ω 5% 1/16W	
R70-	5021484	100 Ω 1% 1/4W		R245	5030052	4 x 4.7K Ω 5% 1/16W	
R71				R336	5012200	2.2K Ω 1% 1/4W	
R75	5030051	4 x 1K Ω 5% 1/16W		R339	5021542	0.22 Ω 5% 1/4W	
R88	5030054	4 x 100K Ω 5% 1/16W					
C1-	4010216	22nF 10% 100V		C43-	4011110	1nF 10% 50V	
C4				C44			
C5	4201179	15000 μ F 20% 50V		C45	4001127	22pF 5% 50V	
C6-	4010216	22nF 10% 100V		C46	4011110	1nF 10% 50V	
C7				C47	4200916	4.7 μ F 20% 25V	
C8	4201406	330 μ F 20% 50V		C48	4000442	2.2nF 5% 50V	
C9	4201163	22 μ F 20% 6.3V		C49	4011135	100nF -20+80% 16V	
C10	4010216	22nF 10% 100V		C50	4201407	820 μ F 20% 25V	
C11	4011135	100nF -20+80% 16V		C51	4011122	10nF 10% 50V	
C12	4010216	22nF 10% 100V		C52	4011110	1nF 10% 50V	
C13	4201178	8200 μ F 20% 10V		C53	4201541	22 μ F 20% 50V	
C14-	4011122	10nF 10% 50V		C54	4011110	1nF 10% 50V	
C15				C55	4001133	68pF 5% 50V	
C16	4201163	22 μ F 20% 6.3V		C56	4001135	100pF 5% 50V	
C17	4001127	22pF 5% 50V		C57	4011135	100nF -20+80% 16V	
C18-	4011122	10nF 10% 50V		C58-	4011122	10nF 10% 50V	
C19				C59			
C21	4011122	10nF 10% 50V		C61	4011135	100nF -20+80% 16V	
C22	4000442	2.2nF 5% 50V		C63	4011122	10nF 10% 50V	
C23	4010216	22nF 10% 100V		C66	4011122	10nF 10% 50V	
C24	4001131	47pF 5% 50V		C71	4011122	10nF 10% 50V	
C25	4011135	100nF -20+80% 16V		C76	4011056	4 x 1nF 10%	
C26	4201163	22 μ F 20% 6.3V		C79	4201348	1 μ F 10% 16V	
C27	4010216	22nF 10% 100V		C80	4001131	47pF 5% 50V	
C28	4201407	820 μ F 20% 25V		C82	4001133	68pF 5% 50V	
C30	4011122	10nF 10% 50V		C86	4200972	4.7 μ F 20% 10V	
C31	4001127	22pF 5% 50V		C87	4201362	2.2 μ F 10% 10V	
C32	4010220	100nF 10% 50V		C92	4001131	47pF 5% 50V	
C33	4011135	100nF -20+80% 16V		C98	4011122	10nF 10% 50V	
C34	4200916	4.7 μ F 20% 25V		C99	4001133	68pF 5% 50V	
C35	4000442	2.2nF 5% 50V		C102	4011135	100nF -20+80% 16V	
C37	4010216	22nF 10% 100V		C103	4201348	1 μ F 10% 16V	
C38	4201348	1 μ F 10% 16V		C104	4011122	10nF 10% 50V	
C39	4201407	820 μ F 20% 25V		C108	4011122	10nF 10% 50V	
C40	4011122	10nF 10% 50V		C111	4011122	10nF 10% 50V	
C41	4011110	1nF 10% 50V		C112	4011056	4 x 1nF 10%	
C42	4201254	33 μ F 20% 16V		C113	4201337	1000 μ F 20% 10V	

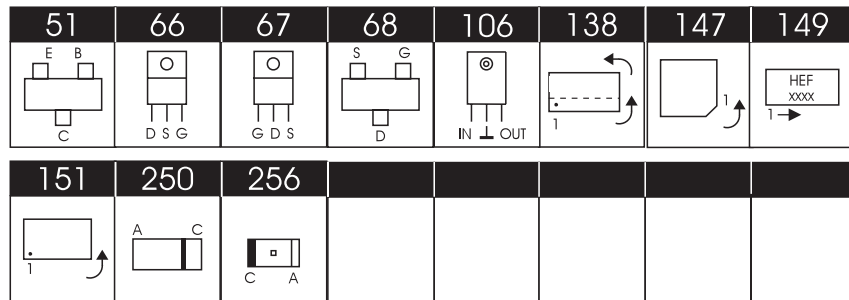

Resistors not referred to are standard, see page 3.13 and 3.14

C114	4001131	47pF 5% 50V	C120-	4000466	470pF 5% 100V
C115	4011122	10nF 10% 50V	C123		
C116	4201348	1µF 10% 16V			

L1	8021113	Coil 47µH 10%	L5	8020916	Coil 47µH 5%
L2	8020772	Coil 10µH 20%	L7	8020916	Coil 47µH 5%
L3-	8020914	Coil 470µH 15%	L8	8021079	Coil 2.2µH 10%
L4			L14	8021113	Coil 47µH 10%

F1▲	6600145	Fuse 5AT 250V	F2▲	6600155	Fuse 1.6AT 250V
-----	---------	---------------	-----	---------	-----------------

T1	8021268	Transformer 2 x 470µH
----	---------	-----------------------

X2	8090230	Crystal 32.768KHz
----	---------	-------------------

B1▲*	8700029	Lithium battery
------	---------	-----------------

P1	7211227	Socket 16 pole	P12	7211222	Socket 6 pole
P2	7211223	Socket 8 pole	P13	7211225	Socket 12 pole
P3	7211222	Socket 6 pole	P14	7211221	Socket 4 pole
P4	7221272	Plug 2 pole	P15	6030359	Ground wire
P5-	7211234	Socket 12 pole	P16	7211221	Socket 4 pole
P8			P17	7221057	Plug 2/3 pole
P9	7221133	Plug 8/8 pole	P20-	7221357	Socket 30 pole
P10	7211229	Socket 20 pole	P21		
P11	7211223	Socket 8 pole			

PCB34, 8000536 Power Supply
Type 2573, 2576

F1▲	6600163	Fuse 5AT 125V
F2▲	6600162	Fuse 1.6AT 125V

Other electrical parts like PCB34, type 2571, 2572, 2574, 2575, 2577, 2580

PCB35, 8006777 Motor Control

IC1Δ	8341747	138	TL7705BCD	IC8Δ	8342552	138	DAC 0854
IC2Δ*	8343407	147	87C654	IC9Δ-	8341041	138	LM324
IC3Δ	8340433	138	74HC86	IC10Δ			
IC4Δ	8340571	138	74HC74	IC11Δ	8341857	138	LM339
IC5Δ-	8343333	149	4094B	IC12Δ-	8341682	151	TCA0372
IC6Δ				IC13Δ			
IC7Δ	8340244	106	LM317	IC25Δ	8341098	138	LM358

TR1-	8321188	51	BC856BW	TR25-	8321187	51	BC846BW
TR3				TR32			
TR4-	8321187	51	BC846BW	TR33	8321188	51	BC856BW
TR6				TR34	8320752	51	BC817-40
TR8-	8321187	51	BC846BW	TR35-	8320856	68	2N7002
TR12				TR36			
TR14-	8321187	51	BC846BW	TR40	8321187	51	BC846BW
TR15				TR43	8321187	51	BC846BW
TR16	8321176	51	FZT951	TR44	8321188	51	BC856BW
TR18-	8321016	67	BUZ71A	TR47-	8321187	51	BC846BW
TR19				TR48			
TR20-	8321154	66	BUZ271	TR49	8320971	51	BC807-40
TR21				TR338	8321188	51	BC856BW
				TR339	8321187	51	BC846BW

▲ symbol of safety component, see page 2.1

* specially selected or adapted sample

Δ indicates that static electricity may destroy the component

D1- D6	8301045	250	BAS216	D30- D32	8301045	250	BAS216
D8- D9	8301045	250	BAS216	D35- D37	8301045	250	BAS216
D12- D15	8300915	250	GF1M	D38	8301074	256	Z12V 2% 0.4W
D16	8301059	256	Z3.3V 2% 0.4W	D39	8301045	250	BAS216
D17- D20	8301076	256	Z15V 2% 0.4W	D42	8301067	250	Z6.8V 2% 0.4W
D21	8301081	256	Z24V 2% 0.4W	D50	8301077	256	Z16V 2% 0.4W
D22	8301045	250	BAS216	D51	8301056	256	Z2.7V 2% 0.4W
D24	8301076	256	Z15V 2% 0.4W	D52- D55	8301045	250	BAS216
R45	5012239	39K Ω	1% 1/10W	R169- R170	5023000	1.2K Ω	1% 1/4W
R58- R64	5012200	2.2K Ω	1% 1/4W	R171	5013256	39K Ω	1% 1/16W
R75	5013235	680 Ω	1% 1/16W	R191	5021484	100 Ω	1% 1/4W
R78	5013235	680 Ω	1% 1/16W	R194- R197	5021151	1.5 Ω	1% 1/4W
R80	5012142	60m Ω		R203	5021225	10K Ω	1% 1/4W
R148- R151	5021151	1.5 Ω	1% 1/4W	R212	5013256	39K Ω	1% 1/16W
R152	5023002	11.3K Ω	1% 1/4W	R225	5011903	180 Ω	1% 1/4W
R153	5021225	10K Ω	1% 1/4W	R226	5011853	158 Ω	1% 1/4W
R156- R157	5021508	47K Ω	1% 1/4W	R247	5021225	10K Ω	1% 1/4W
R159	5021508	47K Ω	1% 1/4W	R278	5021225	10K Ω	1% 1/4W
R160- R161	5021372	5.36K Ω	1% 1/4W	R280	5013264	180K Ω	1% 1/16W
R164	5021372	5.36K Ω	1% 1/4W	R331	5021372	5.36K Ω	1% 1/4W
R165- R166	5012209	1.87K Ω	1% 1/4W	R346- R349	5012200	2.2K Ω	1% 1/4W
R362	5023026	39.2 Ω	1% 1/4W	R365	5370470	10K Ω	
C1	4010274	100nF	-20+80% 25V	C57- C61	4010274	100nF	-20+80% 25V
C2	4001127	22pF	5% 50V	C63- C64	4010220	100nF	10% 50V
C3	4011110	1.0nF	10% 50V	C65	4200898	22 μ F	20% 6V3
C4	4010274	100nF	-20+80% 25V	C66	4201330	220 μ F	20% 50V
C5	4010267	4.7nF	10% 50V	C67- C69	4010220	100nF	10% 50V
C7	4010267	4.7nF	10% 50V	C70	4000409	56pF	5% 50V
C8- C9	4010274	100nF	-20+80% 25V	C71	4010307	33nF	10% 25V
C10- C14	4011110	1.0nF	10% 50V	C72	4000414	150pF	5% 50V
C15- C17	4001141	330pF	5% 50V	C73	4010216	22nF	10% 100V
C18- C19	4011110	1.0nF	10% 50V	C74- C75	4010274	100nF	-20+80% 25V
C20	4001141	330pF	5% 50V	C76- C77	4011110	1.0nF	10% 50V
C21	4011110	1.0nF	10% 50V	C80	4011110	1.0nF	10% 50V
C22- C25	4001141	330pF	5% 50V	C81	4010220	100nF	10% 50V
C26	4011110	1.0nF	10% 50V	C82- C83	4001141	330pF	5% 50V
C27- C28	4001131	47pF	5% 50V	C84	4011110	1.0nF	10% 50V
C29- C31	4011110	1.0nF	10% 50V	C90- C93	4011110	1.0nF	10% 50V
C32- C35	4001141	330pF	5% 50V	C100	4010274	100nF	-20+80% 25V
C36- C37	4011110	1.0nF	10% 50V	C101	4200858	220 μ F	20% 50V
C38	4000287	220nF	-20+80% 25V	C102- C103	4001141	330pF	5% 50V
C39- C42	4010220	100nF	10% 50V	C104	4200916	4.7 μ F	20% 25V
C43	4000287	220nF	-20+80% 25V	C186	4010274	100nF	-20+80% 25V
C44	4011110	1.0nF	10% 50V	C301- C302	4011110	1.0nF	10% 50V
C45	4010271	10nF	10% 50V	C306	4011110	1.0nF	10% 50V
C46	4010274	100nF	-20+80% 25V	C307	4010274	100nF	-20+80% 25V
C47	4010271	10nF	10% 50V	C320	4011110	1.0nF	10% 50V
C49- C50	4010220	100nF	10% 50V	C321	4010220	100nF	10% 50V
C51	4010271	10nF	10% 50V	C430	4011110	1.0nF	10% 50V
C53	4010272	22nF	-20+80% 50V	C501	4001127	22pF	5% 50V
C54- C55	4010220	100nF	10% 50V	C502	4200916	4.7 μ F	20% 25V
				C504	4010274	100nF	-20+80% 25V

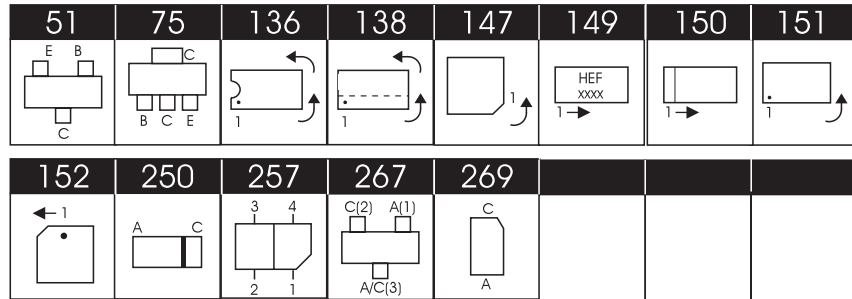

Resistors not referred to are standard, see page 3.13 and 3.14

L1	8020772	Coil 10μH 20%			
L2- L5	8021079	Coil 2.2μH 10%			
X1	8090182	Crystal 16MHz			
CP1	7530117	Contact pin			
P50	7211229	Socket 20 pole	P53	7221159	Plug 2 pole
P51	7221133	Plug 8/8 pole	P54-	7211222	Socket 6 pole
P52	7211053	Socket 4 pole	P55		
MP1	3302352	Screen			
PCB37, 8005314 Lid motor	PE1Δ- PE2Δ	8330235 257	Optocoupler		
	P76	7211075	Socket 6 pole		
PCB41, 8001872 VAM 1250	IC1Δ	8342559 151	LB1619M	IC11Δ	8343709 87C528 OTP
	IC4Δ	8341024 150	4066	IC12Δ	8342941 147 SAA7376GP
	IC5Δ-	8341098 138	LM358	IC14Δ	8343083 149 TDA7072AT
	IC7Δ			IC15Δ	8342495 138 TDA7073A
	IC10Δ	8341612 138	TL7705	IC16Δ	8343365 152 PIC12C508
	TR1	8321184 75	MJD122	TR12	8321196 136 PUMZ1
	TR2-	8320752 51	BC817-40	TR544	8321198 136 PUMX1
	TR3			TR546	8321198 136 PUMX1
	TR5	8321196 136	PUMZ1		
	D1	8330422 269	IR emitter	D5	8300482 250 LL4148
	D3	8301035 267	BAV99W		
	PE1	8330453	Photo transistor		
	R2	5021490 28Ω 1% 1/4W		R46	5012239 39KΩ 1% 1/8W
	R4▲-	5024001 2.2Ω		R61▲	5024001 2.2Ω
	R5▲			R63▲	5024001 2.2Ω
	R15▲	5024001 2.2Ω		R68▲	5024000 1Ω
	R21	5012332 4.7KΩ 1% 1/8W		R78▲	5024001 2.2Ω
	R22	5012267 1.2MΩ 5% 1/8W		R83▲	5024000 1Ω
	R27	5012366 20KΩ 1% 1/8W		R86-	5013250 12KΩ 1% 1/16W
	R28	5012240 100KΩ 1% 1/8W		R87	
	R30	5012154 1KΩ 1% 1/4W		R95-	5013250 12KΩ 1% 1/16W
	R31-	5012237 6.8KΩ 1% 1/8W		R96	
	R32			R97	5013151 680Ω 5% 1/10W
	R33	5011194 220Ω 5% 1/4W		R101	5013003 47Ω 1% 1/16W
	R34-	5012239 39KΩ 1% 1/8W		R103-	5013232 390Ω 1% 1/16W
	R35			R104	
	R36	5012237 6.8KΩ 1% 1/8W		R106-	5013305 22KΩ 1% 1/10W
	R40	5012331 10KΩ 1% 1/8W		R107	
	R41	5011928 47Ω 5% 1/8W		R108	5013239 1.5KΩ 1% 1/16W
	R42	5024000 1Ω		R109-	5013041 432Ω 1% 1/16W
	R44	5012239 39KΩ 1% 1/8W		R110	

▲ symbol of safety component, see page 2.1

Δ indicates that static electricity may destroy the component

R111- R112	5013242	2.7K Ω 1% 1/16W	R113 R116	5013063 5013124	10K Ω 1% 1/16W 1.0K Ω 1% 1/16W
C1	4201359	3.3 μ F 20% 16V	C49-	4011135	100nF -20+80% 16V
C2	4011135	100nF -20+80% 16V	C50		
C4	4011135	100nF -20+80% 16V	C51	4011135	100nF -20+80% 16V
C5	4201359	3.3 μ F 20% 16V	C52	4000424	1nF 5% 50V
C6	4011135	100nF -20+80% 16V	C53	4011135	100nF -20+80% 16V
C7	4010315	22nF 10% 25V	C54	4000412	100pF 5% 50V
C8	4011135	100nF -20+80% 16V	C55	4011135	100nF -20+80% 16V
C11	4011135	100nF -20+80% 16V	C56	4201349	tantal 47 μ F 20% 10V
C12-	4001139	220pF 5% 50V	C57-	4011135	100nF -20+80% 16V
C15			C58		
C16	4010273	47nF -20+80% 50V	C59	4201359	3.3 μ F 20% 16V
C17	4010261	1.5nF 10% 50V	C60	4001131	47pF 5% 50V
C18	4000421	560pF 5% 50V	C61	4201362	2.2 μ F 10% 10
C19-	4001139	220pF 5% 50V	C62	4011135	100nF -20+80% 16V
C20			C63	4201348	1 μ F 10% 16V
C21	4011135	100nF -20+80% 16V	C64	4011122	10nF 10% 50V
C22	4010274	100nF -20+80% 2V	C65	4001141	330pF 5% 50V
C23	4000412	100pF 5% 50V	C66	4011135	100nF -20+80% 16V
C24	4011126	22nF 10% 25V	C67-	4001139	220pF 5% 50V
C25-	4011135	100nF -20+80% 16V	C68		
C26			C69	4201349	47 μ F 20% 10V
C27	4011135	100nF -20+80% 16V	C70-	4011135	100nF -20+80% 16V
C28	4000442	2.2nF 5% 50V	C71		
C29	4001131	47pF 5% 50V	C72	4011123	12nF 10% 25V
C30	4010282	470nF -20+80% 25V	C73	4001141	330pF 5% 50V
C31	4201359	3.3 μ F 20% 16V	C74	4001139	220pF 5% 50V
C32	4010282	470nF -20+80% 25V	C75-	4011135	100nF -20+80% 16V
C33	4011122	10nF 10% 50V	C76		
C34	4000442	2.2nF 5% 50V	C77	4000442	2.2nF 5% 50V
C35	4011135	100nF -20+80% 16V	C78	4011128	33nF 10% 25V
C36	4201359	3.3 μ F 20% 16V	C79	4201349	47 μ F 20% 10V
C37-	4011135	100nF -20+80% 16V	C81	4011130	47nF 10% 16V
C39			C82	4011135	100nF -20+80% 16V
C41	4201359	3.3 μ F 20% 16V	C83	4001141	330pF 5% 50V
C42	4011135	100nF -20+80% 16V	C84	4001138	180pF 5% 50V
C43	4000424	1nF 5% 50V	C85	4201349	47 μ F 20% 10V
C44-	4000400	10pF 5% 50V	C86	4011126	22nF 10% 25V
C45			C535	4011135	100nF -20+80% 16V
C46	4010237	1nF 10% 50V	C540	4000400	10pF 5% 50V
C47	4011135	100nF -20+80% 16V	C541-	4011135	100nF -20+80% 16V
C48	4201359	3.3 μ F 20% 16V	C543		
L1	8021135	Coil 10 μ H	L2	8020822	Coil 3.3 μ H 5%
T1	8021159	Transformer 796KHz			
X1	8090157	Crystal 33.868MHz	X2	8030246	Crystal 12MHz
P42	7210895	Socket 16 pole	P99	7211146	Socket 11 pole
P45	7221157	Plug 6/6 pole			
P46-	7211148	Socket 12 pole			
P47					

PCB95, 8420254 CD mechanism
VAM 1250 (Turntable black)
From serial no. 15143261

WARNING! Static electricity may destroy the component

Mechanical part numbers

90M1	8400214	Gear motor
90M2	8400213	Sledge motor, complete w/wire
90T1	8013551	Transformer 230V f/type 2571, 2572, 2577, 2580
	8013549	Transformer 120V f/type 2573, 2576
	8013548	Transformer 100V f/type 2574
	8013550	Transformer 240V f/type 2575
90P1	6270671	FM socket
90P2	6276977	AM socket
90P3	7219095	Socket f/digital output
91M1	8400212	Clamper motor

Standard resistors

Resistors 5% 1/2 W

	x1	x10	x100	x1k	x10k	x100k	x1M	x10M
1.0		5011000	5011013	5011028	5011044	5010313	5011069	5011083
1.2	5011406	5011001	5011014	5011030	5011045	5011058	5010421	
1.5	5010727	5011002	5011015	5011031	5011046	5011059	5011071	
1.8	5010857	5010787	5011016	5011033			5011072	
2.2	5011335	5010708	5010815	5011034	5011048	5011061	5011074	
2.7	5011612	5010803	5011018	5010055	5011049	5011062	5011075	
3.3	5012147	5011007	5011019	5011037		5011063	5010381	
3.9		5010782	5011021	5010700	5011051		5010392	
4.7	5010765	5011009	5011022	5010035		5011065	5011078	
5.6		5011010	5011023	5011041		5011066		
6.8	5010874	5011011	5011024	5011042	5010810	5011067	5011080	
8.2		5011012	5011026	5011043	5010038	5011068	5011081	

Resistors 5% 1/4 W

	x1	x10	x100	x1k	x10k	x100k	x1M	x10M
1.0	5010592	5010506	5010065	5010040	5010059	5010049	5010054	5010638
1.2		5010595	5010128	5010153	5010046	5010047	5010665	
1.5	5011348	5010468	5010057	5010247	5010053	5010063	5010093	
1.8		5010822	5010362	5010066	5010135	5010072	5010791	
2.2	5010682	5010448	5010092	5010064	5010079	5010120	5010245	
2.7	5010925	5010403	5010000	5010298	5010141	5010083	5010431	
3.3	5011860	5010253	5010044	5010076	5010075	5010117	5010848	
3.9	5011377	5010622	5010070	5010069	5010060	5010073	5010714	
4.7	5010888	5010411	5010058	5010048	5010045	5010077	5011513	
5.6	5010706	5010151	5010067	5010041	5010061	5010071	5010658	
6.8	5010874	5010039	5010144	5010052	5010062	5010074		
8.2	5010880	5010056	5010068	5010154	5010091	5010505		

Resistors 5% 1/8 W

	x1	x10	x100	x1k	x10k	x100k	x1M	x10M
1.0		5011464	5011357	5010816	5010935	5011440	5011459	5020875
1.2		5011351	5011084	5011442	5011338	5011341	5011175	
1.5		5011463	5011443	5011178	5011364	5011398	5011460	
1.8			5011350	5011361	5011344	5011468		
2.2	5011032	5011376	5010886	5011353	5010833	5011369	5011342	
2.7		5011471	5011355	5011362	5011366	5011370	5011478	
3.3		5011519	5011337	5010827	5011346	5011371	5011462	
3.9		5011438	5011883	5011157	5011457	5011372	5020876	
4.7		5011038	5011441	5011363	5010937	5011343	5011611	
5.6		5011412	5011358	5010885	5011166	5011340		
6.8		5011356	5011336	5010839	5011367	5011458		
8.2		5011466	5011354	5011339	5011368	5011373		

Resistors SMD 2% 1/8 W
SMD 5% 1/8 W

Glue dots, approx. 200, part no. 3181932

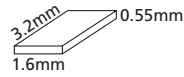

	5%	2%	2%	2%	2%	2%	5%	2%
	x1	x10	x100	x1k	x10k	x100k	x1M	x10M
1.0	5011623	5011647	5011218	5011227	5011241	5011256	5011267	5011730
1.1	5011624	5011648	5011669	5011681	5011689	5011694	5011707	
1.2	5011625	5011649	5011219	5011682	5011490	5011257	5011708	
1.3	5011626	5011650	5011670	5011683	5011242	5011258	5011709	
1.5	5011627	5011651	5011220	5011228	5011243	5011259	5011710	
1.6	5011628	5011652	5011671	5011684	5011690	5011695	5011711	
1.8	5011629	5011653	5011672	5011229	5011244	5011260	5011712	
2.0	5011630	5011654	5011673	5011685	5011691	5011696	5011713	
2.2	5011216	5011655	5011674	5011230	5011245	5011261	5011714	
2.4	5011634	5011656	5011675	5011686	5011246	5011697	5011715	
2.7	5011635	5011657	5011497	5011231	5011247	5011262	5011716	
3.0	5011731	5011658	5011499	5011500	5011692	5011698	5011717	
3.3	5011217	5011659	5011676	5011232	5011248	5011263	5011718	
3.6	5011636	5011660	5011677	5011687	5011249	5011264	5011719	
3.9	5011637	5011661	5011221	5011233	5011491	5011699	5011720	
4.3	5011638	5011662	5011498	5011688	5011492	5011700	5011721	
4.7	5011639	5011269	5011222	5011234	5011250	5011265	5011722	
5.1	5011640	5011663	5011678	5011235	5011493	5011701	5011723	
5.6	5011641	5011664	5011223	5011236	5011251	5011702	5011724	
6.2	5011642	5011665	5011224	5011237	5011693	5011703	5011725	
6.8	5011643	5011666	5011225	5011238	5011252	5011704	5011726	
7.5	5011644	5011667	5011679	5011239	5011253	5011705	5011727	
8.2	5011645	5011270	5011226	5011240	5011254	5011266	5011728	
9.1	5011646	5011668	5011680	5011489	5011255	5011706	5011729	

Resistors SMD 5% 1/10W

Glue dots, approx. 200, part no. 3181932

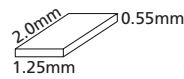

	x1	x10	x100	x1K	x10K	x100K	x1M	x10M
0.0	6000072							
1.0		5011920	5011932	5011944	5011956	5011968	5011980	5012275
1.2	5012326	5011921	5011933	5011945	5011957	5011969	5012267	
1.5	5012379	5011922	5011934	5011946	5011958	5011970	5012268	
1.8	5012380	5011923	5011935	5011947	5011959	5011971	5011989	
2.2		5011924	5011936	5011948	5011960	5011972	5012220	
2.7		5011925	5011937	5011949	5011961	5011973	5012269	
3.3		5011926	5011938	5011950	5011962	5011974	5012261	
3.9		5011927	5011939	5011951	5011963	5011975	5012270	
4.7	5012472	5011928	5011940	5011952	5011964	5011976	5012271	
5.6		5011929	5011941	5011953	5011965	5011977	5012272	
6.8		5011930	5011942	5011954	5011966	5011978	5012273	
8.2		5011931	5011943	5011955	5011967	5011979	5012274	

Resistors SMD 5% 1/16W

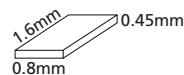

	x1	x10	x100	x1K	x10K	x100K	x1M	x10M
1.0	5013201	5013213	5013225	5013237	5013249	5013261	5013273	5013285
1.2	5013202	5013214	5013226	5013238	5013250	5013262	5013274	
1.5	5013203	5013215	5013227	5013239		5013263		
1.8	5013204	5013216	5013228	5013240		5013264	5013276	
2.2	5013205	5013217	5013229	5013241	5013253	5013265	5013277	
2.7	5013206	5013218		5013242	5013254	5013266	5013278	
3.3	5013207		5013231		5013255	5013267	5013279	
3.9	5013208	5013220		5013244		5013268	5013280	
4.7	5013209	5013221	5013233	5013245	5013257	5013269	5013281	
5.6	5013210	5013222	5013234	5013246	5013258	5013270	5013282	
6.8	5013211	5013223	5013235	5013247	5013259	5013271	5013283	
8.2	5013212	5013224	5013236	5013135	5013260	5013272	5013284	

List of mechanical parts**Top**

13Module	8005313	PCB13, Secondary Keyboard
24Module	8005304	PCB24, Light indication, left
25Module	8005305	PCB25, Light indication, right
27Module	8005377	PCB27, Safety TX
28Module	8005303	PCB28, Safety RX
9001	3162785	Glass lid
9002	3160059	Cover
9003	3169064	Secondary keyboard
	3169297	Secondary keyboard – new colour from serial no. _____
9004	3030123	Hinge f/cover, right
9005	3114481	Chassis top plate, complete (without switch)
	3114488	Chassis top plate, complete (without switch) – new colour from serial no. _____
9006	3458925	Top plate, complete
	3459273	Top plate, complete – new colour from serial no. _____
9007	3375163	Lens
9008	2622510	Holder f/lens f/5 mm diode
9009	3151325	Disc holder, front
	3151724	Disc holder, front – new colour from serial no. _____
9010	3322176	Window, right
9011	2810283	Spring f/disc holder, rear
9012	2810282	Spring f/disc holder, front
9013	3031528	Holder f/springs, rear
9014	3031527	Holder f/springs, front
9015	3947582	Tape
9016	2569447	Guide rail, front
9017	3160063	Cover for chassis top plate
	3160266	Cover for chassis top plate – new colour from serial no. _____
9018	3030124	Hinge f/cover, left
9019	2816288	Spring, chassis connection
9020	3333021	Contact rubber
9021	3114445	Damper f/cover
9022	3356064	Magnet
9023	3031533	Holder f/hinge
9024	3151324	Disc holder rear
	3151723	Disc holder rear – new colour from serial no. _____
9025	3322175	Window, left
9026	3947581	Tape
9027	2569448	Guide rail, rear
	3984049	Barrierta

Survey of screws etc.

1	2013137	Screw 3 x 10mm
2	3103328	Damper
3	3341104	Damper
4	2038111	Screw 3 x 8mm
5	2732129	O-ring
6	2054005	Screw 3 x 8mm
11	2515059	Holder f/wire

Top

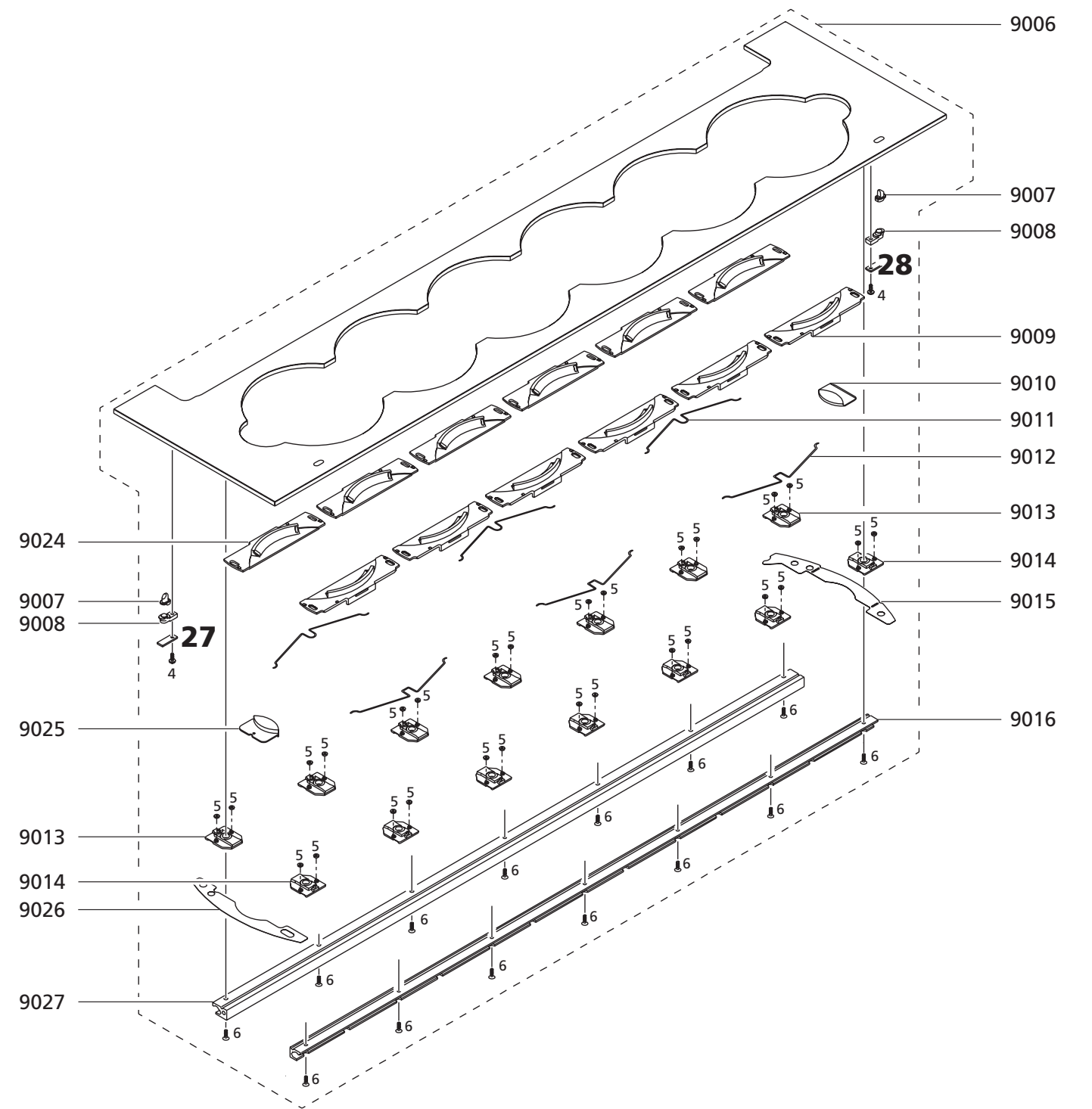
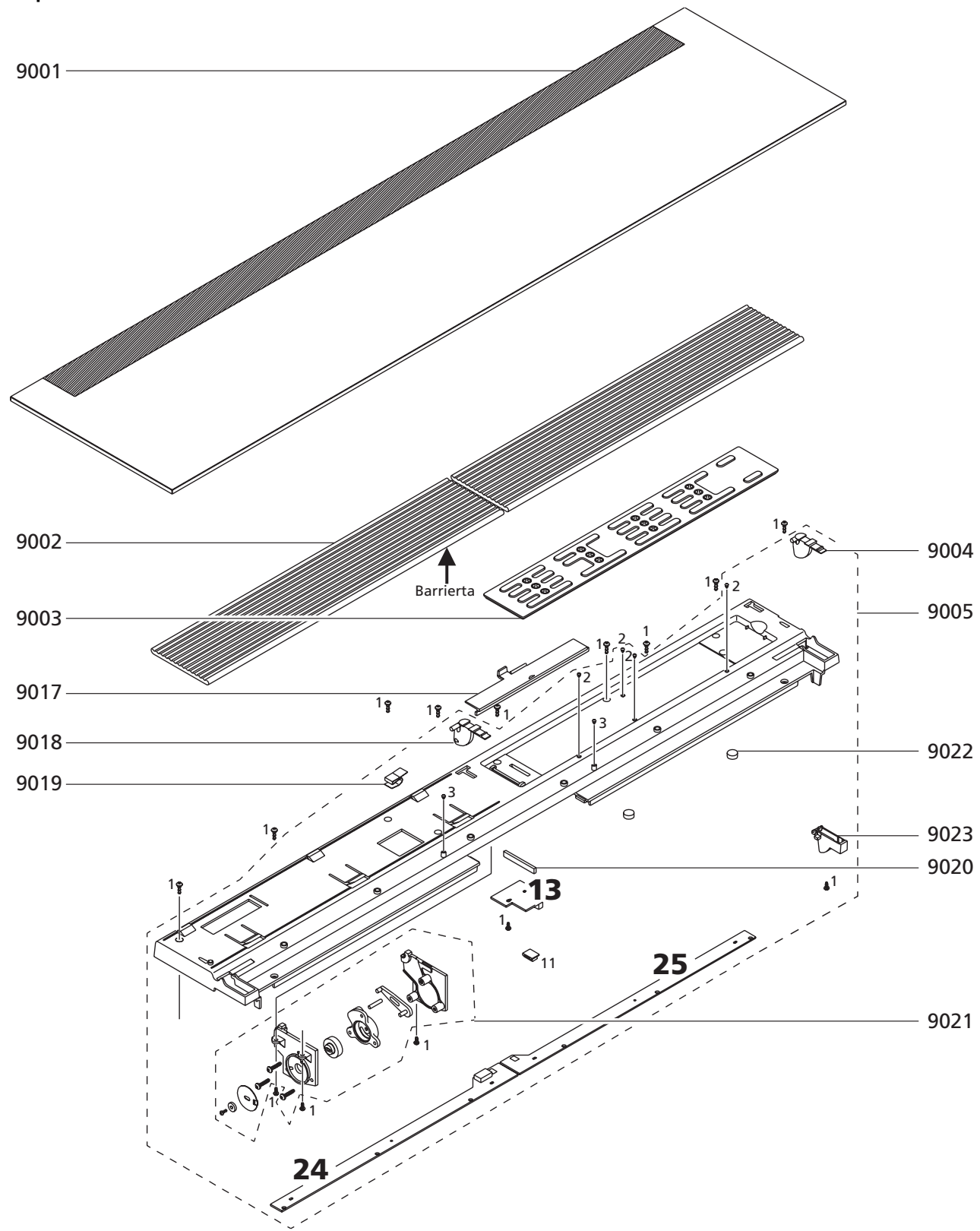

Chassis

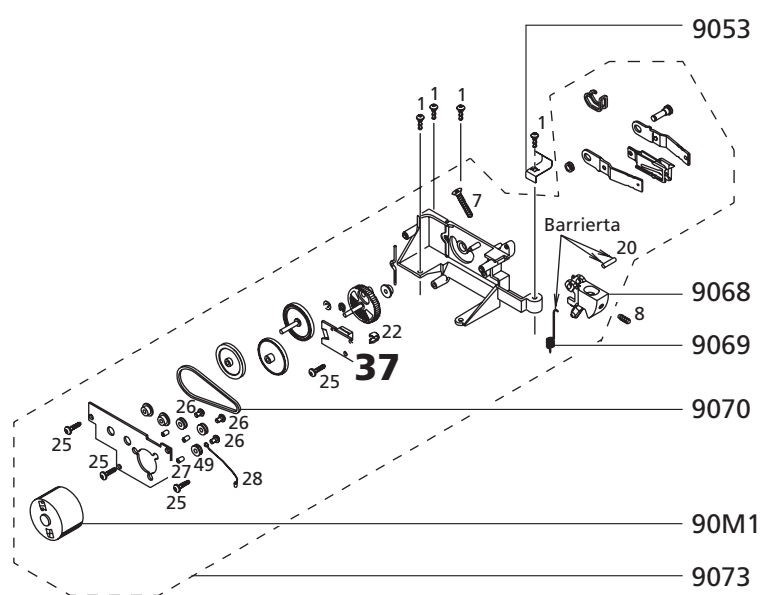
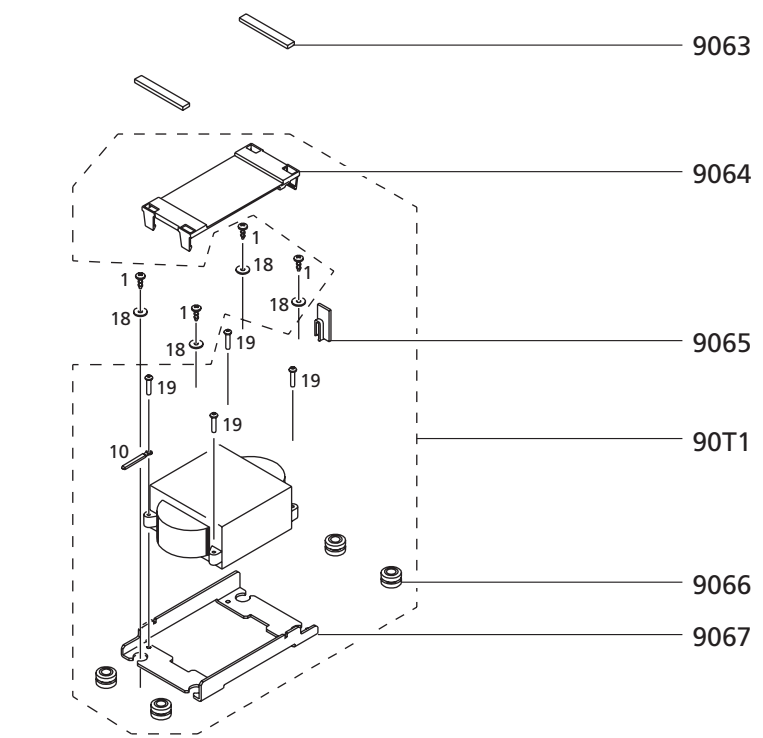
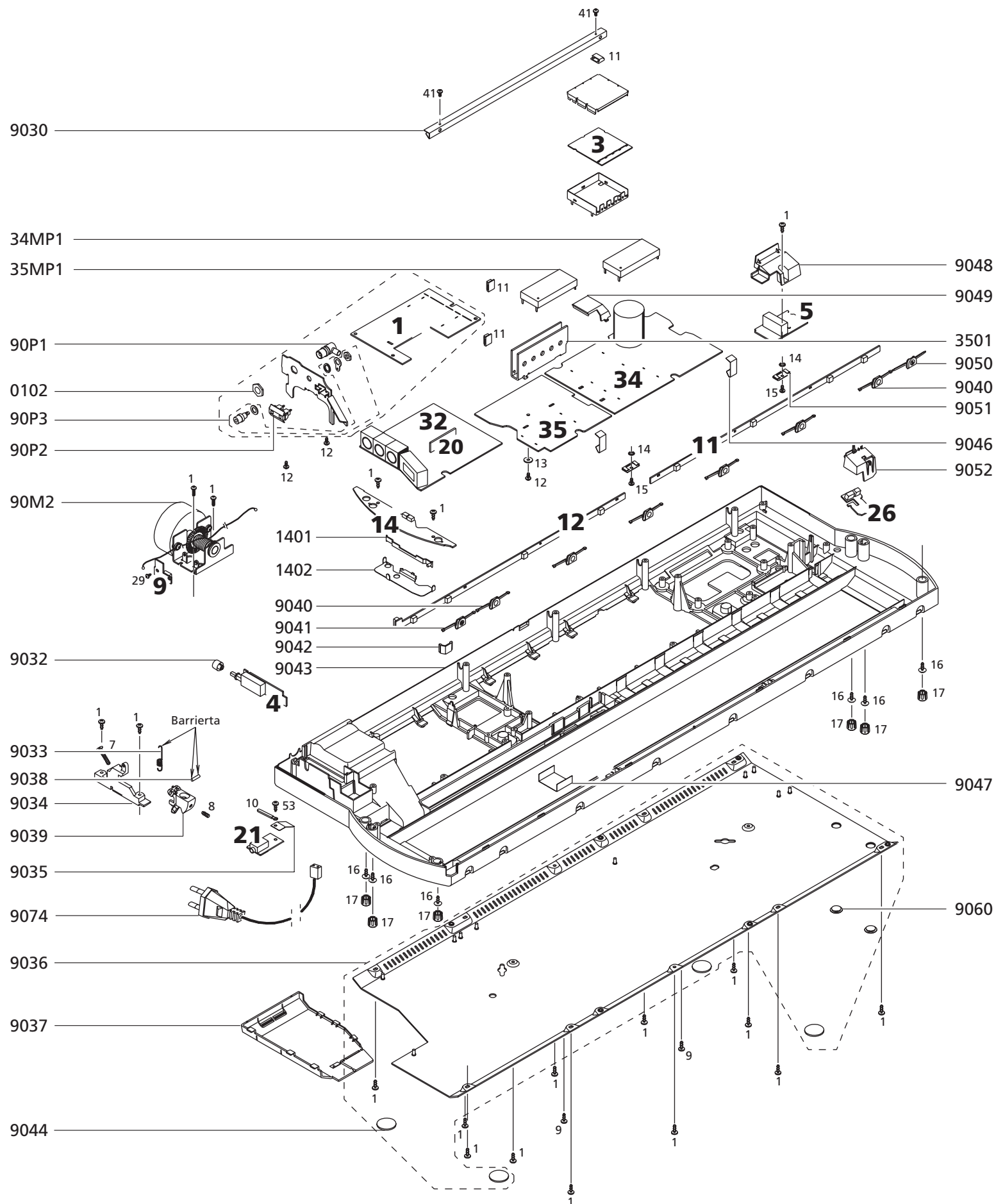

Chassis

01Module	8000462	PCB1, FM/AM-RDS f/type 2571, 2572, 2573, 2575, 2576, 2577, 2580
	8000535	PCB1, FM/AM-RDS f/type 2574
0102	2380170	Nut f/FM socket
<i>If PCB88 are mounted instead of PCB01 see service manual BeoSound 9000 -3538887/3538888</i>		
03Module	8000513	PCB3, Main microcomputer
04Module	8000463	PCB4, Mains filter without mains switch
05Module	8005661	PCB5, Mains relay f/type 2571, 2572, 2574, 2575, 2577, 2580
	8005664	PCB5, Mains relay f/type 2573, 2576
09Module	8005312	PCB9, Sledge Position
11Module	8005295	PCB11, Main Keyboard, right
12Module	8005296	PCB12, Main Keyboard, left
14Module	8005299	PCB14, IR Reciever – Plasma from serial no. 14758303
1401	3302560	Shield, plastic
1402	3302555	Shield
20Module	8001824	PCB20, ML Interface
21Module	8005301	PCB21, Headphone
26Module	8005315	PCB26, End stop detector
32Module	8005399	PCB32, Input/output Select and sound adjustment
34Module	8000512	PCB34, Power supply f/type 2571, 2572, 2574, 2575, 2577, 2580
	8000536	PCB34, Power supply f/type 2573, 2576
34MP1	3302352	Shield
35Module	8006777	PCB35, Motor control
3501	3358312	Heat sink
35MP1	3302352	Shield
37Module	8005314	PCB37, Lid motor
9030	3300149	Shield
9032	2776517	Button, on/off
9033	2810292	Spring f/glass lid, left
9034	3031338	Fitting f/hinge, glass lid
9035	2815045	Spring, chassis connection
9036	3454845	Rear panel
	3454983	Rear panel – new colour from serial no. _____
9037	3162436	Cover
	3162822	Cover – new colour from serial no. _____
9038	2830161	Axle
9039	3131407	Hinge f/glass lid, left
9040	2776487	Button, select
	2776724	Button, select – new colour from serial no. _____
9041	2776493	Button, stand by
	2776725	Button, stand by – new colour from serial no. _____
9042	3322158	IR window
9043	3114453	Chassis
	3114486	Chassis – new colour from serial no. _____
9044	3103326	Foot
9046	2816290	Spring, chassis connection
9047	3302589	Shield f/ribbon cables
9048	3160058	Cover f/PCB5
9049	3302561	Cover f/ribbon cables
9050	2776494	Button, load
	2776726	Button, load – new colour from serial no. _____
9051	3151322	Holder f/screw
9052	3162505	Cover f/PCB26
9053	2815049	Spring, chassis connection
9060	3341088	Plastic plug
9063	3947350	Foam tape
9064	3302568	Cover f/transformer

9065	3302562	Shield f/wire
9066	2938277	Bush
9067	3124131	Fittings
9068	3131384	Hinge f/glass lid, right
9069	2810291	Spring f/glass lid, right
9070	2732120	Rubber belt
9073	2755051	Gearbox, complete
9074	6100273	Mains cable f/ type 2571, 2580
	6100329	Mains cable f/type 2572
	6100307	Mains cable f/type 2573, 2576
	6100331	Mains cable f/type 2574
	6100332	Mains cable f/type 2575
	6100386	Mains cable f/type 2577

90M1	8400214	Gear motor
90M2	8400213	Sledge motor complete w/wire

90P1	6270671	FM socket
90P2	6276977	AM socket
90P3	7219095	Socket f/digital output

90T1	8013551	Transformer 230V AC f/type 2571, 2572, 2577, 2580
	8013549	Transformer 120V AC f/type 2573, 2576
	8013548	Transformer 100V AC f/type 2574
	8013550	Transformer 240V AC f/type 2575

3984049 Barrierta

Survey of screws etc.

1	2013137	Screw 3 x 10mm
7	2058018	Screw 4 x 25mm
8	2072115	Pointed screw 4 x 8mm
9	2011050	Screw 3 x 8mm
10	7530119	Solder tag
11	2515059	Holder f/wire
12	2038137	Screw 3 x 6mm
13	2625002	Washer
14	2390106	Lock washer
15	2058006	Screw 3 x 5mm
16	2058007	Screw 3 x 10mm
17	3341110	Plug
18	2622490	Washer
19	2039064	Screw 3 x 12mm
20	2830161	Axle 3 x 13.8mm
22	3151388	Holder f/optocoupler
25	2054012	Screw 3 x 10mm
26	2036061	Screw 2.6 x 6.5mm
27	2930074	Bush 2.6 x 3.2 x 4.8mm
28	6032961	GND wire
29	2038117	Screw 3 x 4mm
41	2011043	Screw 2.2 x 6mm
49	2938306	Bushing
53	2052009	Screw 3 x 8mm

Sledge

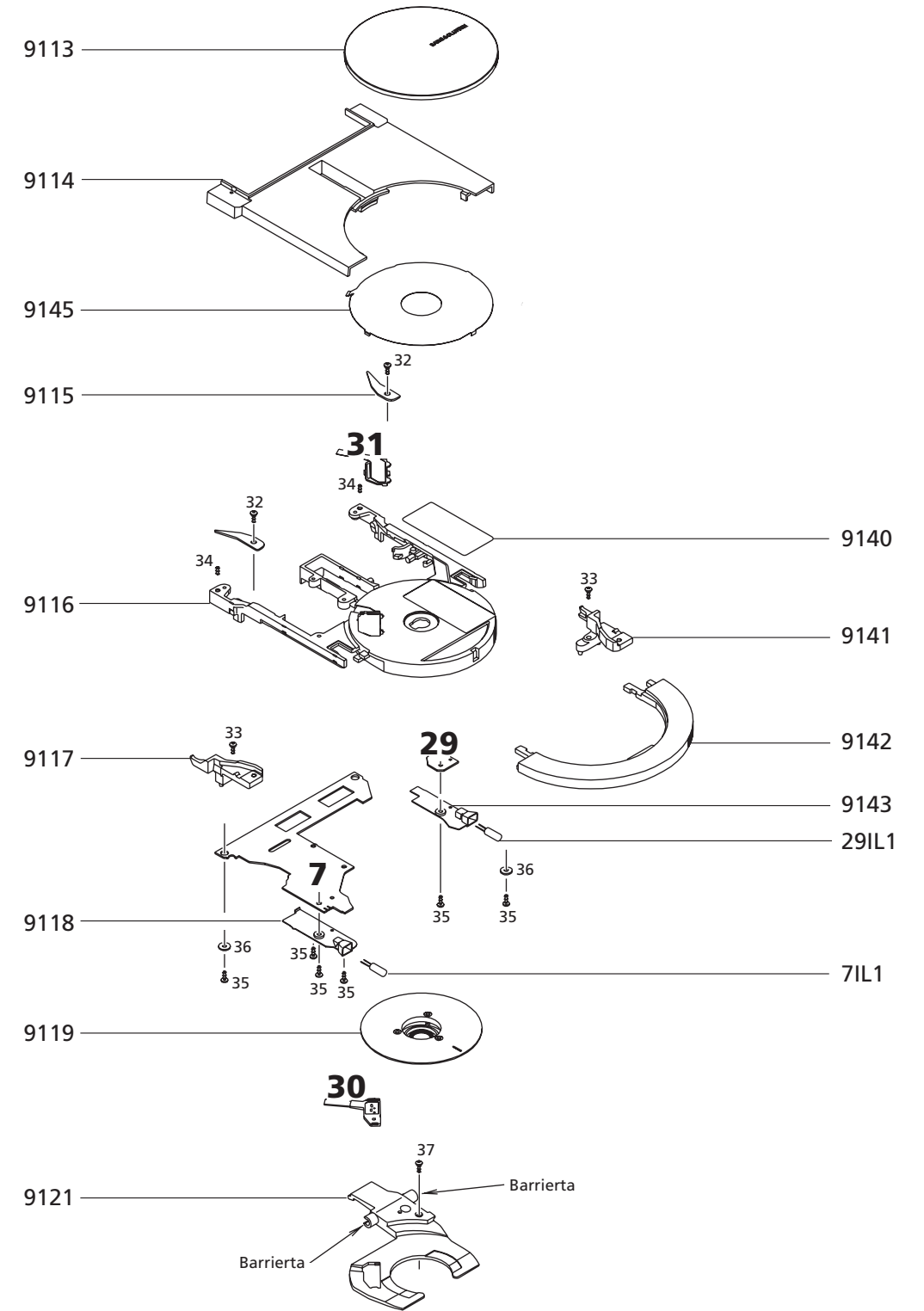
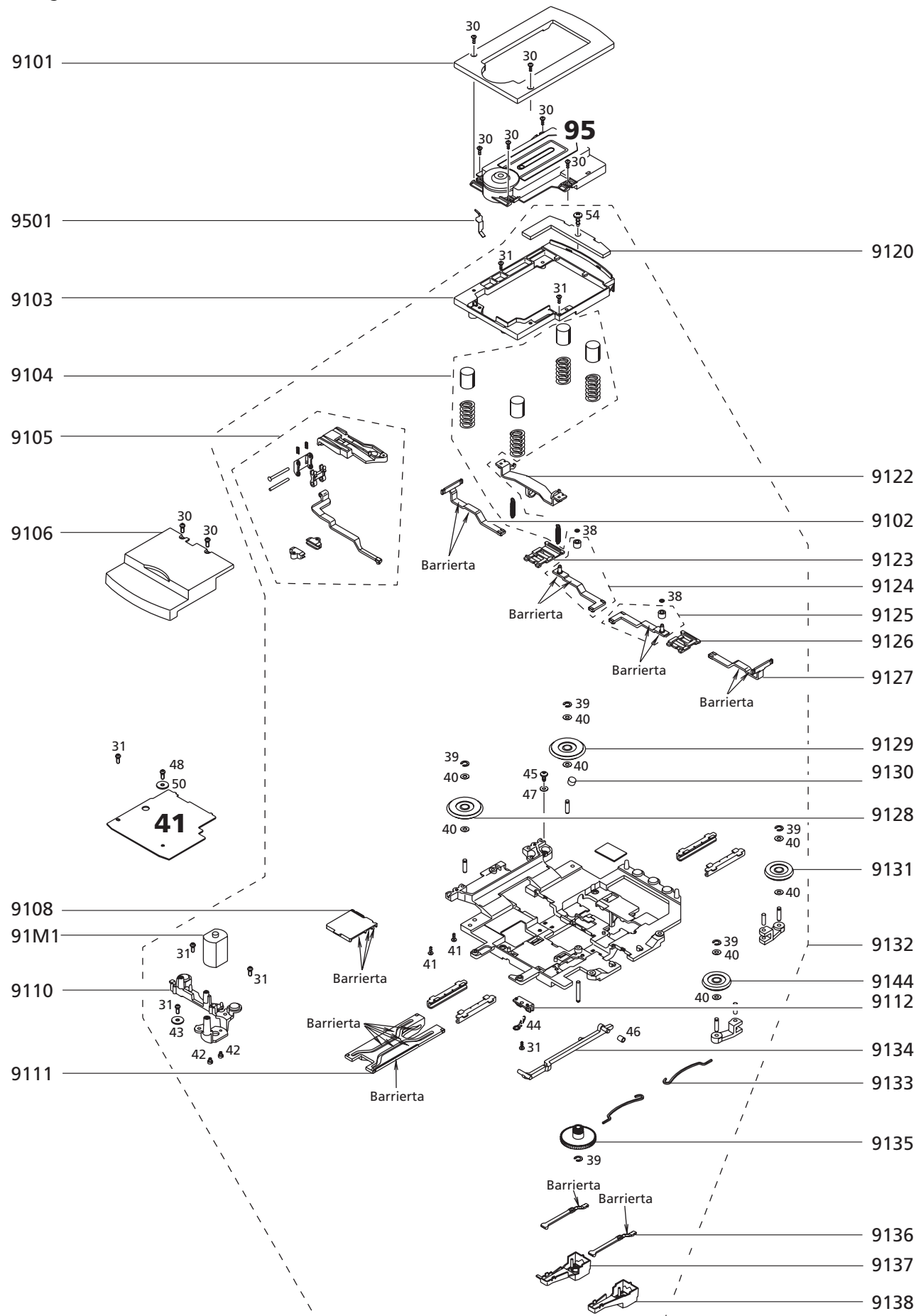

Sledge

07Module	8005364	PCB7, Display
7IL1	8230125	Bulb, 190mA 6.3V
29Module	8005309	PCB29, Lamp
29IL1	8230125	Bulb, 190mA 6.3V
30Module	8001865	PCB30, IR transmitter, tacho clamper
31Module	8001866	PCB31, IR Receiver, tacho clamper
41Module	8001872	PCB41, CD VAM 1250 from serial no. 15143261
95Modul	8420254	CD mechanism VAM 1250 (Turntable black) from serial no. 15143261 WARNING! Static electricity may destroy the component
9501	2815050	Spring, chassis connection
9101	3459272	Cover f/CD mechanism – VAM 1250 from serial no. 15143261
9102	2854206	Arm f/release of CD
9103	3114427	Chassis f/CD mechanism
9104	2810293	Springs f/CD mechanism complete
9105	2854204	Clamper arm
9106	3459011	Cover f/CD PCB
9108	3014128	Holder
9110	3151333	Holder f/springs
9111	3014134	Guide f/clamping
9112	3031534	Holder f/rocker arm
9113	3162462	Cover f/CD clamper
9114	3162477	Top plate for CD mechanism
9115	2810281	Flat spring
9116	3114431	Clamper
9117	2570088	Clamper holder, left
9118	3358331	Heat sink, left
9119	3151684	Holder, clamper
9120	3342058	Counterbalance
9121	2854207	Clamper arm
9122	2854198	Arm f/pull springs
9123	3014112	Holder f/arms, rear
9124	2854203	Arm f/pawl, rear
9125	2854202	Arm f/pawl, front
9126	3014111	Holder f/arms, front
9127	2854206	Arm f/release of CD
9128	3032030	Sledge wheel, rear
9129	3032030	Sledge wheel, rear
9130	3356065	Magnet f/endstop detector
9131	3032031	Sledge wheel, front
9132	3114447	Sledge complete
9133	2810280	Spring f/sledge wheel
9134	2854196	Rocker arm
9135	2700105	Gearwheel
9136	2854205	Adjustment arm f/pull spring
9137	3131399	House f/adjustment arm, rear
9138	3131401	House f/adjustment arm, front
9140	3181048	Lable, laser
9141	2570084	Clamper holder, right
9142	3370164	Lens f/light
9143	3358332	Heat sink, right
9144	3032031	Sledge wheel, front
9145	3302594	Cover
91M1	8400212	Clamper motor
	3984049	Barrierta

Survey of screws etc.

30	2052007	Screw 2.5 x 6mm
31	2058013	Screw 2.5 x 6mm
32	2058011	Screw 3 x 5mm
33	2058015	Screw 2.5 x 10mm
34	2072116	Pointed screw 3 x 4mm
35	2054003	Screw 2.2 x 4.5mm
36	2625044	Washer
37	2052004	Screw 2.2 x 5mm
38	2622110	Washer
39	2390001	Washer
40	2620020	Washer
41	2011043	Screw 2.2 x 6mm
42	2058008	Screw 2 x 2mm
43	2622041	Washer
44	7530087	Solder tag
45	2036036	Screw 2.5 x 4mm
46	3333022	Damper f/rocker arm
47	2622379	Washer
48	2036082	Screw 2.5 x 8mm
50	2625044	Washer
54	2052009	Screw 3 x 8mm

Guide f/wire and ribbon cables

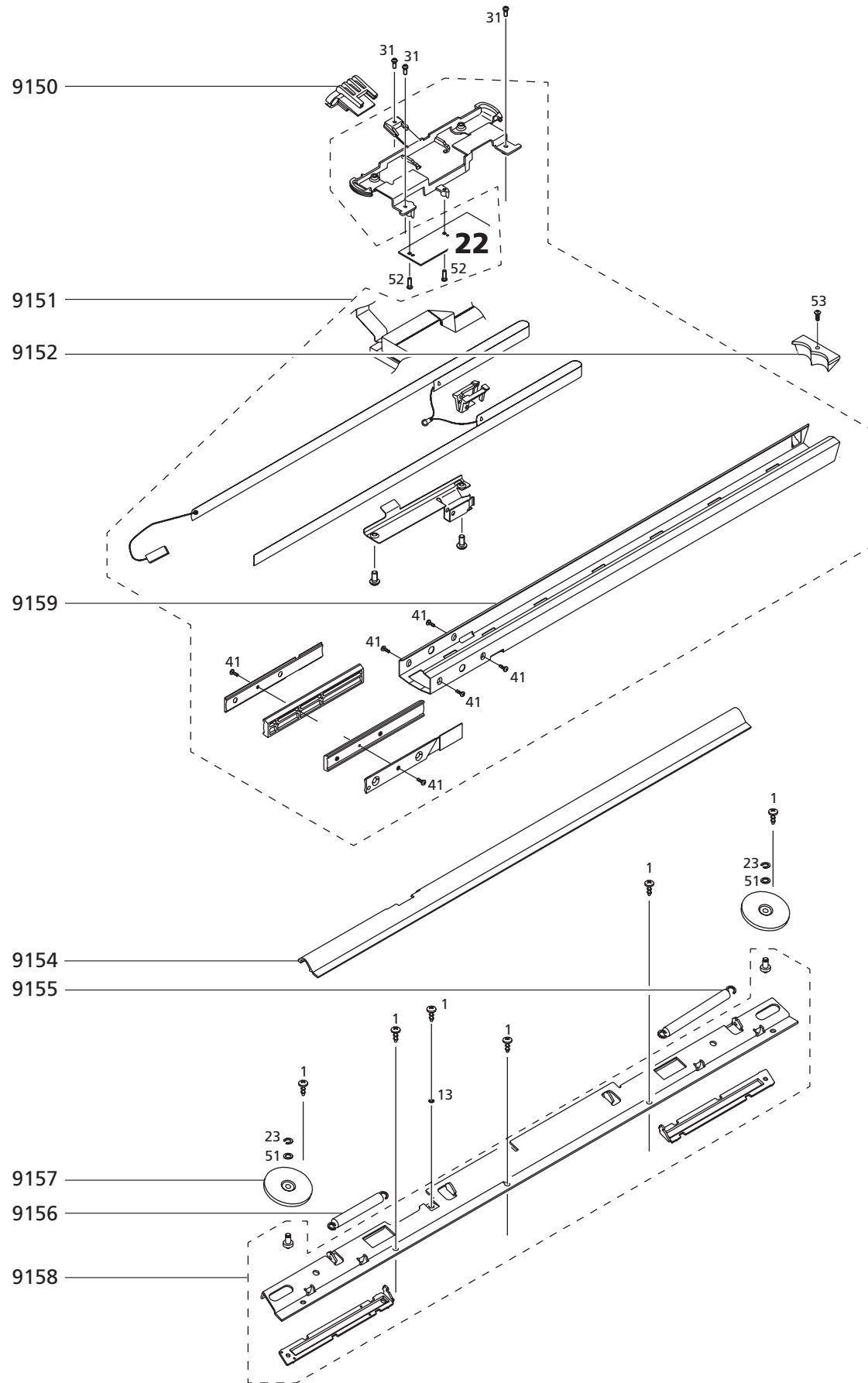

Guide f/wire and ribbon cables

22Module 8000514 PCB22, Clamper position

9150	2510178	Holder
9151	3015197	Ribbon cables complete with guide
9152	3151463	Holder
9154	2560284	Cover
9155	2810277	Spring f/wire, right
9156	2810278	Spring f/wire, left
9157	3032029	Wheel f/wire
9158	3031535	Fittings f/wire
9159	3014098	Guide f/ribbon cables

Survey of screws etc.

1	2013137	Screw 3 x 10mm
13	2625002	Washer
23	2390002	Washer
31	2058013	Screw 2.5 x 6mm
41	2011043	Screw 2.2 x 6mm
51	2622499	Washer
52	2036064	Screw 2.5 x 5mm
53	2013150	Screw 2.5 x 8mm

Packing

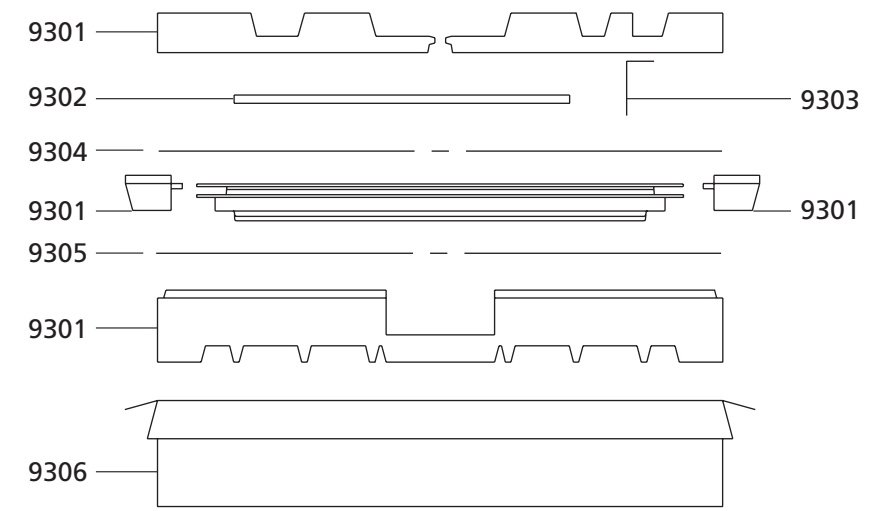

9301	3397920	Foam packing, set
9302	3397983	Insert f/cover
9303	3392468	Insert f/clamper
9304	3946038	Foil 1 x 1m
9305	3946038	Foil 1 x 1m
9306	3392228	Outer carton
	2777037	Holder f/handle
	2777038	Handle

Wire bundles

See wiring diagram page 2.3.
The part no. is printed on the diagram above the wire bundle, as shown.

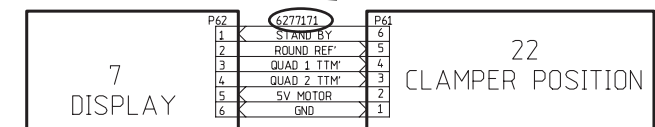

Accessories	8720047	AM loop antenna
	8720048	FM antenna

Guide	3505745	Danish
	3505746	Swedish
	3505747	Finnish
	3505748	English, EU
	3505749	German
	3505750	Dutch
	3505751	French
	3505752	Italian
	3505753	Spanish
	3505754	Portuguese
	3505755	Greek
	3505756	Brazil
	3505757	Polish
	3505758	Russian
	3505759	Hebrew
	3505760	Japanese
	3505761	Taiwanese
3505762	Korean	
3505763	Norwegian	

Reference book	3508389	Danish
	3508390	Swedish
	3508391	Finnish
	3508392	English, EU
	3508393	German
	3508394	Dutch
	3508395	French
	3508396	Italian
	3508397	Spanish
	3508398	Portuguese
	3508399	Greek
	3508400	Brazil
	3508401	Polish
	3508402	Russian
	3508403	Hebrew
	3508404	Japanese
	3508405	Taiwanese
3508406	Korean	
3508407	Norwegian	

Product Informations	3507000	English
	3507001	Danish
	3507002	German
	3507003	French

Circuit descriptions	3540273	English
	3540274	Danish
	3540275	German
	3540276	French
	3540277	Dutch

Bracket 2053

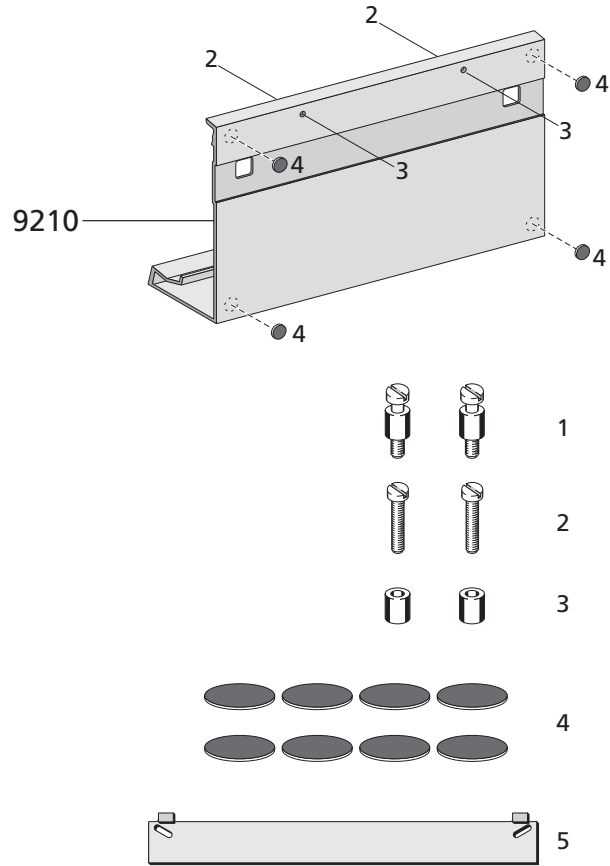

9210 2569423 Bracket

Survey of screws etc.

- | | | |
|---|---------|--------------------|
| 1 | 2930133 | Adjustment bushing |
| 2 | 2042211 | Screw 4 x 12mm |
| 3 | 2930132 | Bushing |
| 4 | 3103326 | Foot, 1 piece |
| 5 | 2569438 | Wall profile |
-

Parts not shown

- | | |
|---------|------------------------|
| 3103372 | Foot, set incl. screws |
| 3040037 | Red adjustment key |
| 3390455 | Bag w/parts |
| 3392440 | Outer carton |
| 3397970 | Foam packing |
| 3502941 | Setting-up guide |
| 3504533 | Setting-up guide |
-

Wall Bracket horizontal 2054

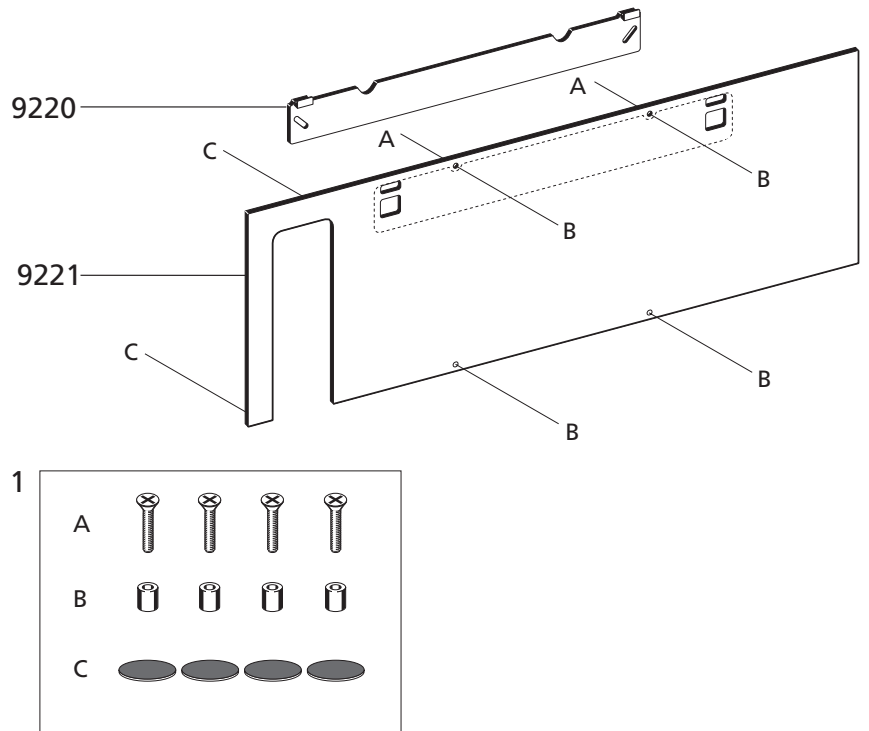

9220	2569470	Wall profile
9221	3452692	Rear plate

Survey of screws etc.

1	3390533	Bag w/parts
---	---------	-------------

Parts not shown

3392518	Packing, complete
3502942	Setting-up guide

Cable cover 2062



2569440	Profile
3031545	Bracket
3392517	Packing, complete

Wall Bracket Vertical 2063

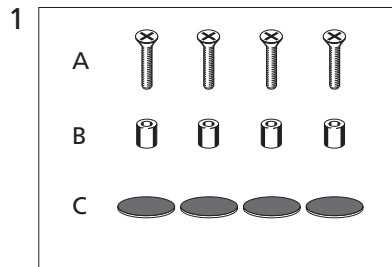
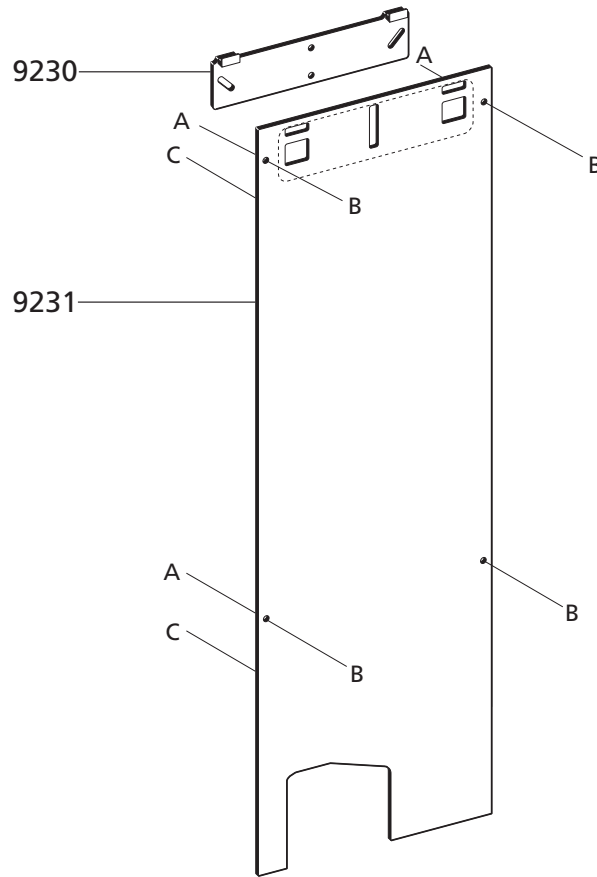

9230	2569471	Wall profile
9231	3452693	Rear plate

Survey of screws etc.

1	3390533	Bag w/parts
---	---------	-------------

Parts not shown

3392518	Packing, complete
3502984	Setting-up guide

Stand 2065

Adjustable in two heights

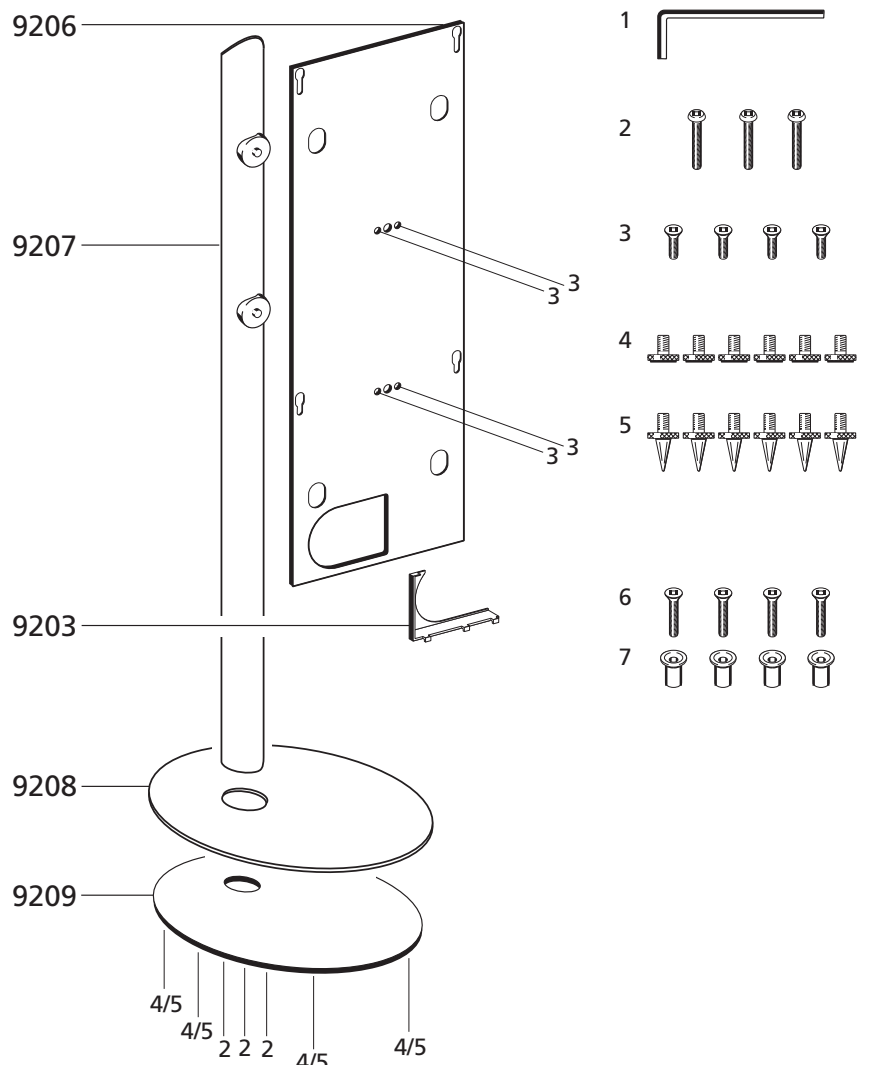

9203	3162463	Cover
	3162823	Cover – new colour from serial no. _____
9206	3452701	Back plate
9207	2569601	Tube, high 118,6 cm
9208	3162731	Cover plate, aluminium
9209	2752070	Iron foot

Survey of screws etc.

1	3040023	Allen key
2	2058009	Allen screw 4 x 25mm
3	2058010	Screw 4 x 12mm
4	3103392	Foot, "Soft"
5	3103390	Foot, "Spike" adjustable
6	2058012	Screw 4 x 20mm
7	2930135	Bushing

Parts not shown

3040037	Red adjustment key
3390550	Bag w/parts
3397944	Foam, 1 piece
3392621	Wrapper
3504553	Setting-up guide

Adjustments

Adjustment of sensitivity of finger protection system

1. Install the glass lid, and close the lid. (Important!)
2. Switch off the product at the mains switch.
3. Connect an ohmmeter between ground and the middle pin on 35R365, and adjust to minimum value.
4. Connect an oscilloscope (DC) to 35CP1 (coordinate 2A).
5. Switch on the product.
6. Select CD6. The sledge will now try to move but it must stop.
7. Adjust by means of 35R365 until the bottom of the pulse is between 1.5 and 2V.

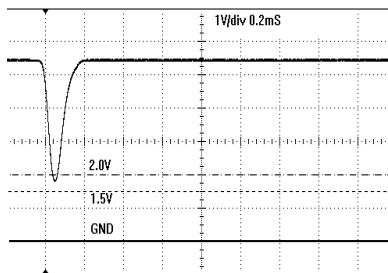

After approx. 30 seconds the pulses will disappear.

8. Switch off the mains, and then short-circuit 35CP1 to ground which is the chassis of the cooling plate.
9. Connect an oscilloscope (set to position AC) to the middle pin on 35R365.
10. Switch on the product.
11. Select CD6. The sledge will now try to move but it must stop.

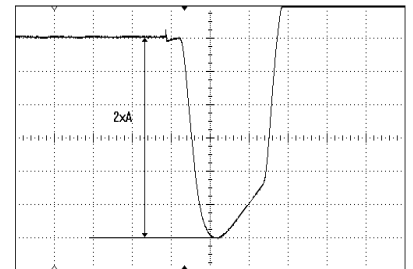
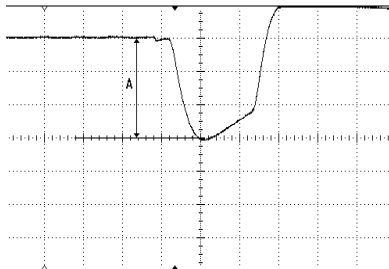

12. Then measure the pulse height.
13. Now adjust by means of 35R365 until the pulse has twice the amplitude measured under point 12 above.
14. Switch off the mains. Remove the short-circuiting lead between 35CP1 and ground.
15. Switch the product back on, and select CD6. The sledge will now move quickly to the CD6 position.
16. Then select CD1 and check with a finger that the sledge is able to stop.
17. Open the glass lid.
18. Select CD6, and the sledge will now move slowly towards the CD6 position.
19. Then select CD1 and check with a finger that the sledge is able to stop.

Mechanical adjustments

Adjustment of CD mechanism

See Brief Operation Guide, page 1.5.

Adjustment of lid

Remove the left aluminium plate (see point 2 under dismantling for further information, if necessary) and open the lid covering the secondary keyboard.

Adjust the lid until it is parallel with the top plate (15 mm).

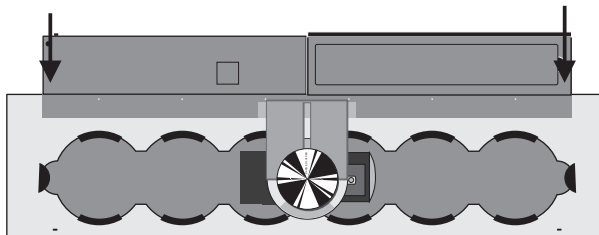

Adjustment of clamber arm

Remove the top plate for the clamber arm (see dismantling for further information, if necessary).

Adjust the clamber until it is parallel with the top plate.

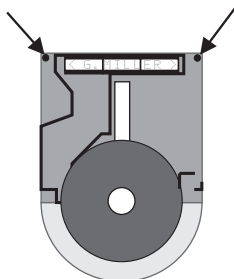

Test modes

Because of the high complexity of BeoSound 9000 MKIII it is important to use the built-in test and service functions during and after servicing the product. A good approach to finding an error is test mode 27 in which a report can be seen. Remember always to execute test modes 71 and 73 after a repair situation.

TM (test mode) names/function for adjustments and service

Tuner test modes

TM 01: Automatic offset-adjustment for FM
TM 02: Manual offset-adjustment for FM
TM 03: Status for offset-adjustment
TM 04: Variant status
TM 06: Check RDS name
TM 07: Setting up of tuner variant

Master test modes

TM 20: Test of display functions
TM 21: Open ML-out
TM 22: Test of keyboard functions
TM 23: Software version
TM 24: Service operation counter
TM 25: Open ML-in
TM 27: Service of error detection
TM 28: Validity test for ROM/RAM/EEPROM
TM 31: Set default settings
TM 32: Read-out of product ID
TM 34: Read-out of options
TM 35: Power down ON
TM 36: Power down OFF

CD test modes

TM 61: Focus on
TM 62: Focus off
TM 63: Starts turntable motor
TM 64: Stops turntable motor
TM 65: Light pen to outermost position
TM 66: Light pen to the innermost position
TM 67: Starts CD
TM 68: Stops CD
TM 71: Mechanical test of finger protection, sledge and led
TM 73: Adjustment of autopositioning
TM 74: Safeguard level set to max

WRONG SRC/TM

Having selected test mode, select CD before using test modes associated with CD and select radio before using test modes associated with radio.

If you select a test mode that is not valid, e.g. a CD test while CD has not been selected, the display will read:

WRONG SRC/TM

Test mode activating (by Beo4)

Wait 20 - 30 sec. after connecting to mains.

Since BeoSound 9000 is in option 0 if Power Link speakers are not connected, the option has to be changed to 1.

Option 1 can be obtained by short-circuiting pins 2 and 4 on the Power Link sockets. See Brief operation guide for further information, if necessary.

By means of remote control from St.by (can only be done if the product is not in option 0) :

Press **SHIFT 9 0 2 5 8** with no more than 2 sec. between the individual entering.

The remote control has to be in RADIO or CD option.

In test modes the tuner is fully functional and may overwrite the display but the TM will continue.

Select CD to view CD test modes.

Deactivating test mode (by Beo4)

Press ● and the display shows "TESTMODE OFF" or disconnect from mains.

TM01

Automatic offset-adjustment for FM.

This is done by letting the tuner search for the frequency 100 MHz (84 MHz for Japan) and when the signal is found the offset will be calculated and stored in NVRAM. The display shows "A OFFSET".

If failure the display shows "TM ERROR".

TM02

Manual offset-adjustment for FM.

This is done by keying in a frequency.

The tuner search for this frequency and the offset will be calculated and stored in NVRAM.

The display shows "M OFFSET".

If failure the display shows "TM ERROR".

TM03

Read-out offset status.

If the offset-adjustment is needed the display shows "TM ERROR".

If the result of the offset-adjustment is positive the display shows "OFFSET n".

If the result of the offset-adjustment is negative the display shows "OFFSET -n".

The figure n is in steps of 12.5 kHz.

TM04

Read-out variant status:

EUROPA (EU) FM, EUROPA (EU) FM/AM, USA (US) and JAPAN (JP). The display shows e.g. "EU FM/AM".

If failure the display shows "TM ERROR".

TM06

Checking that the RDS name of the radio programme in question is RDS-PS.

The display shows "TM OK".

If wrong RDS name or if name is missing the display shows "TM ERROR".

TM07

Tuner variant setup:

If from EU or AUS to US:

Key in the 3 digits indicating the choice.

No. 0: 003 = variant US

No. 1: 001 = RDS on, or 000 = RDS off

No. 2: 175 = FM starts in 500 kHz

No. 3: 216 = FM stops in 500 kHz

No. 4: 075 = Deemphas in μ s

No. 5: 000 = LW starts in kHz dividing with AM raster. 0 if no LW

No. 6: 000 = LW stops in kHz dividing with AM raster. 0 if no LW

No. 7: 053 = MW starts in kHz dividing with AM raster. 0 if no MW

No. 8: 171 = MW stops in kHz dividing with AM raster. 0 if no MW

No. 9: 010 = AM raster. Steps in kHz. 0 if no AM

If from US or AUS to EU.

No. 0: 001 = variant EU FM. (002 if EU FM/AM)

No. 1: 001 = RDS on, or 000 = RDS off

No. 2: 175 = FM starts in 500 kHz

No. 3: 216 = FM stops in 500 kHz

No. 4: 050 = Deemphas in μ s

No. 5: 017 = LW starts in kHz dividing with AM raster. 0 if no LW

No. 6: 031 = LW stops in kHz dividing with AM raster. 0 if no LW

No. 7: 058 = MW starts in kHz dividing with AM raster. 0 if no MW

No. 8: 179 = MW stops in kHz dividing with AM raster. 0 if no MW

No. 9: 009 = AM raster. Steps in kHz. 0 if no AM

If from EU or US to AUS

No. 0: 005 = variant AUS

No. 1: 001 = RDS on, or 000 = RDS off

No. 2: 175 = FM starts in 500 kHz

No. 3: 216 = FM stops in 500 kHz

No. 4: 050 = Deemphas in μ s

No. 5: 000 = LW starts in kHz dividing with AM raster. 0 if no LW

No. 6: 000 = LW stops in kHz dividing with AM raster. 0 if no LW

No. 7: 058 = MW starts in kHz dividing with AM raster. 0 if no MW

No. 8: 179 = MW stops in kHz dividing with AM raster. 0 if no MW

No. 9: 009 = AM raster. Steps in kHz. 0 if no AM

TM20

Checking the display by showing 2 types of icons in 2 rounds to test the pixels.
Press **GO** to shift between icons in the display.

TM21

Opens the signal from AUX-plug to the ML-output.

TM22

Test of key-board functions.

By pressing a key for instance **CD** the display will show "CD".

The testmode can only be ended by IR-remote control command "STOP".

This testmode can only be activated by IR-remote control command.

TM23

Read out of Software version.
Press **GO** to continue.
APP xx.xxx = Application processor. (Main CPU)
OS xx.xxx = APOS
IOP xx.xxx = I/O processor
MOT xx.xxx = Motor processor. (MOT-FEP)
TUN xx.xxx = Tuner processor. (Tuner-FEP)
CD xx.xxx = CD processor. (CD-FEP)

TM24

Service running counter.
First the Standby time will appear.
Press **GO** to toggle between the different counters.

- Standby time
- Radio-mode time
- CD-mode time
- AUX-mode time
- ML net radio time
- ML net music time
- Time with other ML source
- Theft protection active time

Number of times the theft protection has been unlocked.
Number of times the product has been powered up.
All numbers are stated at intervals of 10. (e.g. 3 = 30.)
When all counters have been shown the display will ask for a new test mode.

TM25

Opens ML-in.
A source must be selected to have a correct measurement.
Signal coming from the ML-in, exit on the PL and AUX as by normal selection.

TM27

Service Error detection.
The last registered errors regarding EEPROM, ML, IIC-bus, RS232 driver, CD, CD-sledge and lids can be readout. This test mode is also used for deleting all error-registrations.
To toggle between error indications press **GO**. When all errors are read press **GO** to reset all errors registered or press **STOP** to keep error register.
By pressing **▲** or **▼** the time of the errors will be shown.
YY.MM.DD - hh.mm.ss.
MEM: last EEPROM error.

- 02: EEPROM writes error
- 03: EEPROM reads error
- 04: EEPROM reads error only FF
- 11: EEPROM writes overflow
- 12: EEPROM controls init fail
- 13: EEPROM controls calloc fail
- 99: EEPROM content error

ML: Last error regarding to ML.

- 08: Link tied down
It is impossible to transmit on Master Link because it is pulled low. The error may occur if there is an error in the Master Link driver circuit, or because a short circuit has occurred on the Master Link.
- 16: Link tied up
It is impossible to transmit on Master Link because it is pulled low. The error may occur either because the pull-up resistance in the system has become too low or as a result of an error in the data receiver circuit.
- 32: Configuration impossible
Disconnect all products from the Master Link system and reconnect them one by one until the error shows up.

IIC: Component which gave the last error regarding IIC-bus.

- 102: Tuner FEP
- 104: Motor FEP
- 136: Sound Processor
- 208: Clock

SER: The last error from the RS232 driver.

- 01: CDA queue not attached
SW communication error
- 02: CDA error timeout
SW communication error
- 03: CDA error unknown buf addr
Communication error. Check the bus and the components connected to it.
- 04: CDA error data expected
Communication error. Check the bus and the components connected to it.
- 05: CDA error unknown CMD
Communication error. Check the bus and the components connected to it.
- 06: CDA error checksum
Communication error. Check the bus and the components connected to it.
- 07: CDA error RX timeout
SW communication error
- 08: CDA error out of buffers
- 09: CDA error uart overrun
- 10: CDA error uart framing
- 11: CDA error uart parity

CD: CD error.

- 02: Focus error
The CD could not focus within the time limit.
- 03: Radial error
Set when the CD did not get on track after several retries.
- 04: Turntable motor error
Set when the disc did not spin up or down within the time limit.
- 05: PLL lock error
Set when PLL is out of lock during tracking mode.
- 06: Jump error
Set when a seek could not be performed or an error occurred during a binary search.
- 07: Subcode error
Set when a subcode could not be read within the time limit.
- 08: TOC read error
Set when the TOC could not be read, no access possible to lead-in.

- 20: Serial communication overrun error
Expected command byte, but received a data byte.
 - 22: Serial communication noise error
Check sum did not match.
 - 23: Serial communication software error
Queue full.
 - 37: Selection error
Unknown command
- OS: Error in the operation system.
- 08: IL TGL from APOS to FEP
 - 09: IL RX TX BUF limit
 - 13: FEP does not exist
- IO: Last error in the I/O driver.
- 01: IIC1 2 error
 - 05: Cannot configure FEP
 - 06: FEP communication error
 - 07: IL TGL from FEP to APOS
 - 08: IL TGL from APOS to FEP
 - 09: Interlink RX TX BUF limit
 - 14: FEP does not exist
 - 33: MLSL timeout error
 - 34: MLSL TX BUF full TGL does not send
 - 35: ML key lost key repaired
 - 36: External communication not allowed in preproject
 - 37: LSL format error
 - 38: LS IR format error
 - 39: LSL TX imposs
 - 40: LSL link tied up
 - 41: LSL link tied down
 - 42: Generic ICB error
 - 43: ICB L7 timeout
 - 44: ICB L7 illegal timeout
 - 45: ICB L7 out of repositories
 - 46: ICB L7 illegal L7 ack
 - 47: ICB L7 Acknowledge unexpected
 - 48: ICB L7 read response unexpected
 - 49: ICB L7 illegal resource type
 - 50: ICB L7 resource still running
 - 51: ICB L7 resource already free
 - 52: ICB L7 illegal IOP service
 - 53: ICB L7 illegal IOP object
 - 54: ICB L7 telegram flushed
 - 55: ICB L7 resource disabled
 - 56: ICB L7 HW clock illegal command
 - 57: ICB L7 HW clock illegal event
 - 58: ICB L2 retrans limit reached
 - 59: IIC component disabled
 - 60: CDS bus disabled
 - 61: Power down of IOP impossible

AP: Application processor errors.

- 16: Illegal timer ID
- 17: Timer not free
- 21: Illegal date value
- 22: Illegal time value
- 23: Illegal timer parameters
- 32: Illegal simple message ID
- 33: Out of message buffers
- 34: Message buffer virtual limit reached
- 64: Non ISR func. called from ISR
- 65: Physical stack limit reached
- 66: Stack virtual limit reached
- 67: Out of IAS objects
- 68: IAS signal lost
- 69: Overflow in IAS FIFO
- 70: IR queue not attached
- 71: LSL queue not attached
- 72: Scan queue not attached
- 73: Active keyscan queue not attached
- 74: Uart 0 queue not attached
- 75: TIIC queue not attached
- 76: RIIC queue not attached
- 77: Out of power down callback OBJ
- 78: Power down entered with timer running
- 79: Watchdog reset

IOP: Last error in the I/O microprocessor.

- 02: ICB layer 2 timeout
- 03: ICB layer 7 illegal service
- 04 ICB layer 7 illegal object
- 05: Reg mem data frame not valid
- 06: Data frame not valid
- 07: Illegal port ID
- 08: LSL TX impossible
- 09: LSL tied up
- 10: LSL tied down
- 11: IIC slave buffer full
- 12: IIC slave transmit timeout
- 13: IIC illegal switch port
- 14: IIC2 slave addressed
- 15: IIC conditional polling timeout
- 16: IOP IIC error
- 17: PD entered while service waitning
- 18: TP ICBL7 illegal command
- 19: TP module HW error APOS
- 21: TP clock error APOS

SLG: Sledge errors.

- 13: CC info finger detected.
The IR beam in the finger protection system has bin broken while the sledge was moving.
- 30: CC sledge pos count error.
A counter error has been registered on the signal from the sledge tacho. It is registered at 35IC2 pin 1, 44, 5 and 9.

- 31: CC sledge pos opto error.
Microprocessor 35IC2 cannot register pulses from 9PE1.
- 32: CC sledge calib switch error.
Microprocessor 35IC2 cannot register the signal REF. POS from the end stop detector at pin 20.
This error also occurs if the tacho system is not working.
- 33: CC clamp pos error.
The clamper cannot go to the desired position. The reason may be that it is locked or that there it is an error on PCB22, clamper position, or that the motor driver is defective.
- 38: CC current sense error.
35IC2 pin 35 registers that the sledge uses too much current. The reason may be that the sledge is blocked or that the sledge control is defective.
- 39: CC disc detect error.
The disk detector is not operating. Carry out test mode 71 to test the circuit.
- 40: CC sat sense error.
35IC2 pin 37 registers that the sledge uses too much current. The reason may be that the sledge is blocked or that the sledge control is defective.
- 41: CC sledge blocked error.
The sledge is blocked, or the power supply to the sledge control may be too low.
- 42: Finger protection is out of operation.
The finger protection circuit is out of operation. Use test mode 71 during troubleshooting.

PLT: Lid errors.

- 17: CC info plate pos error.
Position error. The lid may be blocked, the lid motor may be defective, or the optocouplers 37PE1 and 37PE2 may be defective.
- 37: CC door pos error / CC plate pos error.
(Occurs during test mode 71 only) Position error. The lid may be blocked, the lid motor may be defective, or the optocouplers 37PE1 and 37PE2 may be defective.

APS: Autoposition errors.

- 10: CC info P bit not found error
P bit has not been detected. If a CD-I Ready disc for example has been played back at some point or if there is an error in the detection circuit. The error has been detected at pin 11 of 35IC2.
- 11: CC info too many P bits.
Too many P bits have bin detected. May be caused by scratches in the disk.
- 12: CC info TTM opto adjusted.
Information that the turntable tacho has been adjusted. Data in EEPROM has been lost.
- 14: CC info TTM pos count error.
An error has occurred in connection with scanning of the turntable motor position. The position is not stored in EEPROM. Optocoupler / tacho may be defective.
- 15: CC info TTM timeout error.
It has taken more than 5 seconds to carry out autopositioning. The turntable motor driver may be defective.
- 18: CC info TTM pos opto error.
It has not been possible to make a correct adjustment of the autopositioning circuit. The optocoupler circuit may be defective.
- 19: CC info TTM ref opto error.
The signal ROUND REF from PCB31 IR tacho clamper RX is missing.

- 34: CC TTM pos count error.
A counter error has occurred in connection with an adjustment (test mode 73).
Check the signals QUAD 1 TTM and QUAD 2 TTM from PCB31 IR tachometer RX.
- 35: CC TTM pos opto error.
(Occurs during test mode 73 only) It has not been possible to carry out a correct adjustment of the aut positioning circuit. The optocoupler / tachometer circuit may be defective.
- 36: CC TTM ref opto error.
(Occurs during test mode 73 only) The signal ROUND REF from PCB31 IR tachometer RX is missing.

PWR: Power errors.

- 20: CC power error.
Mains drop-out while the sledge was moving.
- 100: CC motor FEP power fail.

TM28

This TM checks the function of ROM, RAM, EEPROM. (O, A, P).
To readout TM, O and A have to be (+).
E.g. MEM +- indicates error in the EEPROM.

TM31

Default settings for sales purposes.

Option: 1

Volume: 32

Balance: 0

Bass: 0

Treble: 0

Loudness: OFF

Radio programmes erased.

CD settings erased.

Timer settings erased.

After default settings the display shows "DEFAULT TM ERROR".

If error occurs in TM the display will show "TM ERROR".

Item-number, serial-number, type-number, master pin-code, running counter and all offset adjustments will not be erased.

TM32

ID-readout of the product.

Press **GO** to toggle between the ID-numbers.

Item no = 7 figures.

Type no = 4 figures.

Serial no = 8 figures.

Master PIN = OK or ERROR.

If error in the readout all figures = 0.

TM34

Option readout.

TM35

Power down ON.

When power down mode is possible the display = "TM OK".

TM36

Power down OFF.
When power down mode is not possible the display = "TM OK".

To use CD test modes it is necessary to select CD, in the TM the HF-signal will not be used

TM61

Focus ON.
The CD-pen will try to focus.
This TM can only be turned off by using TM62.

TM62

Focus OFF.
The CD-pen will be turned OFF.

TM63

Starts turntable motor.
In order to ensure a controlled rotation, TM61 should be completed before you activate this Test Mode.
This TM can only be turned off by using TM64.

TM64

Turns off the turntable motor.

TM65

Light pen to outermost position.
The optical pickup unit goes to the outermost position and stays there.
This TM can only be turned off by TM66. Do not give other commands in the meantime.
Display = "LIGHTPEN OUT".

TM66

Light pen to the innermost position.
The optical pickup unit goes to the innermost position and stays there.
Display = "LIGHTPEN IN".

TM67

The CD starts playing.

TM68

The CD stops playing.

TM71

Mechanical test of finger protection, sledge and led.
CDs must be loaded in positions 6, 5, 4, 3, 2 but no CD in position 1, (the position nearest the LOAD button).
The CD must be stopped and the lid must be shut when the test is activated.
The following sequence is executed:

- End stop is found, the sledge runs slowly.
This tests sledge tacho, sledge motor, calibration of the end stop switch.
- Lid opens and closes.
This tests optocoupler for glass lid.
- Test of finger protection circuit.
- The sledge runs the longest possible distance slowly once, then quickly twice. This tests the sledge tacho for phase errors between quad 1 and quad 2 (the finger

protection circuit is cut out during the test). When the sledge is running it must run "properly".

- The lid opens.
- Autocalibration of CD positions.
This tests calibration, disc detector, sledge motor, sledge tacho, clamper motor, clamper optocoupler, and jaws.
The clamper is noise-optimized during the autocalibration.
- The sledge runs to the original position, i.e. the sledge position prior to activation of sledge test.

When error in CD test mode the Error-number refers to TM27 CD-errors.

TM72

Release of sledge.

Display = "RELEASE SLG"

When test mode 72 has been used the mains voltage to the product has to be disconnected to ensure correct calibration.

TM73

Adjustment of autopositioning.

Test mode 71 must have been executed.

- Press **SHIFT 9 0 2 5 8**
- Open the lid and load a CD.
- The sledge must be placed in the position where the CD is loaded.
- Press **7 3**
- If the test is OK the display will show: APS ADJUSTED.
- If an error has occurred during the test, the applicable error code can be seen during a test mode 27.

TM74

Changing transmitter power for the finger protection circuit.

Safeguard level is set to maximum and the display show: SAFEGUARD TM

This function can only be switched off by the main switch.

Glass doors lock

The glass doors can only be locked if the product is in Standby, the glass doors closed and only by remote control.

Press **SHIFT 9 0 3 6 9** with no more than 2 sec. between the individual entering.

The display shows "LOCKED".

To unlock the glass doors press **SHIFT 9 0 3 6 9** with no more than 2 sec. between the individual entering.

The display shows "UNLOCKED".

The function will be remembered in NVRAM after disconnecting from mains.

Theft protection

The theft protection is a 4 digit PIN-code of the user's own choice, which must be entered if the product has been disconnected from the mains for 15-30 min.

The theft protection is always deactivated from the factory, it is up to the user to activate it.

If the theft protection is activated, and the product has been without mains for 15-30 minutes, the user will be asked to enter the 4 digit PIN-code.

Before the product is handed in to service it is a good idea to ask the customer to deactivate the theft protection.

Service code

If the PIN-code is activated and the product is in a service situation, there is a possibility of 12 hours service by entering a 5 digit Service code which is 11111. This gives 12 hours of full functionality to service the product and make module changes without naming/registering the exchanged modules to the Customer's product. The 12 hours are only running when the product is connected to mains! If the customer's PIN-code or Master-code is entered the exchanged modules will be named/registered to the product. Registration of the modules cannot be changed. The service code must be entered when a source is selected and the product asks for the PIN-code "PIN _ _ _ _" press down the ▼ button (Keyboard) for three seconds and the display now writes "PIN _ _ _ _ _", press ▼▲ (Keyboard) to select digit, press OK (Keyboard) to accept digit.

Master code

If the PIN-code has been forgotten (5 tries every 3 hours with mains connected), the only way to unlock the product again is by entering the 5 digit Master code. The Master code can be ordered at Bang & Olufsen.

When a source is selected and the product asks for the PIN-code "PIN _ _ _ _" press down the ▼ button (Keyboard) for three seconds and the display asks for 5 digits instead of 4: "PIN _ _ _ _ _" ; enter the 5 digit Master code. Press ▼▲ (Keyboard) to select digit, press OK (Keyboard) to accept digit.

How to order Master code

The Master code is ordered by sending a request either via the Retail System or on the Master code formula, if non of these options are available please contact Bang & Olufsen.

Exchange of micro-processor module PCB3

When exchanging PCB3 remember to insert the EEPROM from the defective module, because it contains valuable data (serial no., type no., PIN-code etc.). The data is not transferred to the new module until you have been in contact with the theft protection or after 12 hours connected with mains. This means that you can try out a new PCB3 without transferring the products serial no. etc.

Note !

When the serial no. has been transferred to the micro-processor it can only be used for this specific product. Otherwise the module must go back to Bang & Olufsen's module repair department as an exchange module to be erased again. If the product functions are OK the theft protection is also OK; there is no need for testing the functionality of the theft protection.

When the product is connected to mains, wait 20-30 sec. before operating. All addresses in ML hav to be updated after disconnecting mains voltage.

Exchange of software EEPROM on PCB3

When exchanging the EEPROM on PCB3, the data from the micro-processor will be written into the EEPROM when selecting any source e.g. RADIO.

It is possible to borrow an EEPROM from another BeoSound 9000 to test if there is suspicion of a fault in the original EEPROM. The EEPROM will always adopt the data from the main micro-processor.

Exchange of both micro-processor module PCB3 and software EEPROM on PCB3

If both the micro-processor and the EEPROM need to be exchanged it is necessary to have them pre-programmed from Bang & Olufsen with the correct serial number, otherwise they will not work.

Please contact Bang & Olufsen.

Important

When the product is reconnected to mains, wait 20-30 sec. before operating. All addresses in ML hav to be updated after disconnecting mains voltage.

Set and enter PIN code

It is the customer's choice whether or not to activate the PIN code system.

However, if the customer has chosen to activate the system, BeoSound 9000 is protected against theft with a four-digit PIN code.

The use of a PIN code means that if BeoSound 9000 is disconnected from the mains for more than 15-30 minutes, the system can only be activated again by keying in a personal PIN code.

If the PIN code is not entered, BeoSound 9000 automatically switches to standby after 3 minutes.

If a wrong PIN code is entered, you get five attempts to key in the code, after which the system is switched off and cannot be switched on for 3 hours.

Should you forget the PIN code, please contact a retailer who can assist you in receiving a Master code from Bang & Olufsen. You need the Master code to reactivate BeoSound 9000.

Activate the PIN code system

The PIN code system is easily activated, and you choose the four-digit code yourself.

Press **MENU** **◀◀STOP** (Beo4) to key in a four-digit PIN code of your own choice.

NEW PIN appears briefly, and PIN _ _ _ _ appears.

Key in a four-digit PIN code of your own choice.

The PIN code is not displayed.

Press **GO** (Beo4) to store the PIN code.

CONFIRM appears briefly, and then PIN _ _ _ _ appears. Re-enter your code. The PIN code is not displayed. Press **GO** (Beo4) to store.

STORED appears, indicating that your PIN code is stored.

Enter the PIN code

If the PIN code system is activated and your BeoSound 9000 is disconnected from the mains for more than 15-30 minutes, you are requested to key in the four-digit PIN code when the system is first switched on. The cue PIN _ _ _ _ is displayed.

Key in your personal PIN code. The PIN code is not displayed. When the four-digit code has been entered, the display returns to the relevant source e.g. RADIO 1.

Deactivate the PIN code system

You can deactivate the PIN code system at any time. All you need is to enter your PIN code first and then deactivate the system.

Press **MENU** **◀◀** **STOP** (Beo4) or press **▼** **▼** **PAUSE** buttons (Keyboard) to key in the four-digit PIN code.

PIN _ _ _ _ appears. Key in your personal four-digit PIN code.

The PIN code is not displayed. NEW PIN ? appears.

Press **▲** or **▼** (Keyboard) to switch the display. PIN OFF appears.

Press **GO** (Beo4) or **OK** (Keyboard) to deactivate the PIN code system.

DELETED appears, indicating that the PIN code system is deactivated.

If you have forgotten your PIN code

If you have forgotten your PIN code, you must contact a retailer who then requests a five-digit Master code from Bang & Olufsen. Once you have keyed in this code, your BeoSound 9000 is operational again and the PIN code system is deactivated.

The cue PIN _ _ _ _ is displayed.

Press down the **▼** button (Keyboard) for three seconds and the display asks for 5 digits instead of 4: "PIN _ _ _ _ _" ; enter the 5 digit Master code. DELETED appears, indicating that the PIN code system is deactivated and the set is ready for use.

Change PIN code

The PIN code can be changed at any time. However, for security reasons it is only possible to change the PIN code five times within a period of 3 hours.

Press **MENU** **◀◀** **STOP** (Beo4) or press **▼** **▼** **PAUSE** buttons (Keyboard) to key in the four-digit PIN code.

PIN _ _ _ _ appears.

Key in your personal PIN code.

The PIN code is not displayed.

NEW PIN ? appears.

Press **GO** (Beo4) or **OK** (KeyBoard) to enter a new PIN code.

PIN _ _ _ _ appears.

Key in the new PIN code. The PIN code is not displayed.

Press **GO** (Beo4) or **OK** (KeyBoard) to store.

CONFIRM appears briefly, and then PIN _ _ _ _ appears.

Re-enter the new PIN code. The PIN code is not displayed.

Press **GO** (Beo4) or **OK** (KeyBoard) to store. STORED appears, indicating that your changed PIN code is stored.

Replacement of components

Exchange of microprocessor module PCB3

When exchanging PCB3 remember to insert the EEPROM from the defective module, because it contains valuable data (serial no., type no., PIN-code etc.). The data is not transferred to the new module until you have been in contact with the theft protection or after 12 hours connected with mains. This means that you can try out a new PCB3 without transferring the products serial no. Etc..

Note !

When the serial no. has been transferred to the micro-processor it can only be used for this specific product; it must go back to Bang & Olufsen's module repair department as an exchange module to be erased again.

If the product functions are OK the theft protection is also OK; there is no need for testing the functionality of the theft protection.

When the product is connected to mains, wait 20-30 sec. before operating.

All addresses in ML has to be updated after disconnecting mains voltage.

Exchange of software EEPROM on PCB3

When exchanging the EEPROM on PCB3, the data from the micro-processor will be written into the EEPROM when selecting any source e.g. RADIO.

It is possible to borrow an EEPROM from another BeoSound 9000 to test if there is suspicion of a fault in the original EEPROM. The EEPROM will always adopt the data from the main micro-processor.

Exchange of both micro-processor module PCB3 and software EEPROM on PCB3

If both the micro-processor and the EEPROM need to be exchanged it is necessary to have them pre-programmed from Bang & Olufsen with the correct serial number, otherwise they will not work.

Please contact Bang & Olufsen.

Replacement of 7DP1, 7DP2 or 7DP3

When display 7DP1, 7DP2 or 7DP3 is replaced, all three displays must be replaced to ensure an uniform light intensity.

Replacement of 29IL1 and 7IL1

When 29IL1 or 7IL1 is replaced, both light bulbs must be replaced.

Replacement of light indicator

When either Light indicator PCB's is replaced, it must be fixed again with double-sided adhesive tape.

Replacement of PCB35, PCB27, PCB28 and the mechanical parts of the finger protection system

Remember to carry out adjustment of the sensitivity of the finger protection system.

Repair tips

Voltage to sledge motor

Disconnect the voltage supply to the sledge motor while servicing (lift 35P53).

Repair of aut positioning

TM73 is used in connection with repair of aut positioning. The circuit can be measured each time the test is run. Use a storage oscilloscope, if necessary.

Only the signals SWAB and SDAB can be measured during lead-in, i.e. during ordinary play-back of a CD.

Aut positioning errors of less than 5 degrees may occur in rare cases.

Why does the product not work?

If the product does not work, the reason may be one of the following:

When the glass lid is not installed the sledge may stop during movement. That is because the IR beam in the finger protection system transmits at reduced power when the lid is closed. Run the lid hinges to the open position for maximum IR transmitter power (see test mode 74, if required).

A lid acknowledgment must be given for the product to operate. The lid may be subject to an adjustment error so that no acknowledgment is received.

If the finger protection beam is broken, the sledge cannot move.

If end stops have not been detected, the product will not operate.

If the optocouplers in the product are affected by external light the product will not operate.

CD

In connection with repair of the CD the following tips may be useful:

THE PHOTO DIODES AND THE LASER ARE MORE SENSITIVE TO STATIC ELECTRICITY THAN THE MOS IC'S. OMISSION TO TAKE THIS INTO CONSIDERATION DURING SERVICING MAY REDUCE THEIR LIVES DRAMATICALLY. SO BE SURE THAT THE WORK SITE IS PROTECTED AGAINST STATIC ELECTRICITY.

The product may not be connected to the mains while the CD mechanism or PCB41 are removed.

Focus can be checked by placing a CD over the light pen. The light pen will now "follow" the CD (up/down).

In normal operation the CD will first search for Focus, and when that has been found it will start the turntable motor, i.e. if the motor cannot start, the reason may be that focus has not been found.

The CD can run without clasper and disc detector. In test mode select CD as source. Move the sledge to position 1, disconnect the voltage supply to the sledge motor while servicing the CD (lift 35P53), load a CD, press CD, and the CD can now be played back.

By using one of the flat cables provided at the back of the service manual (type 252x - 3538847 or order no. 6277184) the display can be engaged by connecting 7P63 and 34P8.

In connection with test modes the CD has reduced operation.

If the clamper arm is not installed, no tachometer pulses will come from the autopositioning system, and the turntable motor may therefore run in the reverse direction.

SLEDGE

In connection with repair of the sledge function the following tips may be useful:

The wire for the sledge must be placed correctly; otherwise periodic errors may occur.

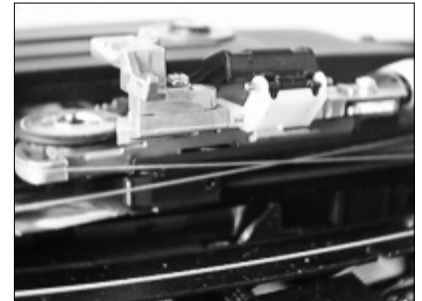
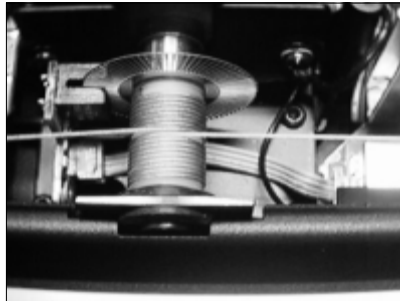

GLASS LID

The glass lid may be "pulled" out of mesh. The product has been designed in that way in order to allow the customer to remove his CD's without switching on the power supply to the product.

MISCELLANEOUS

When replacing the top, the number label must be transferred to the new top.

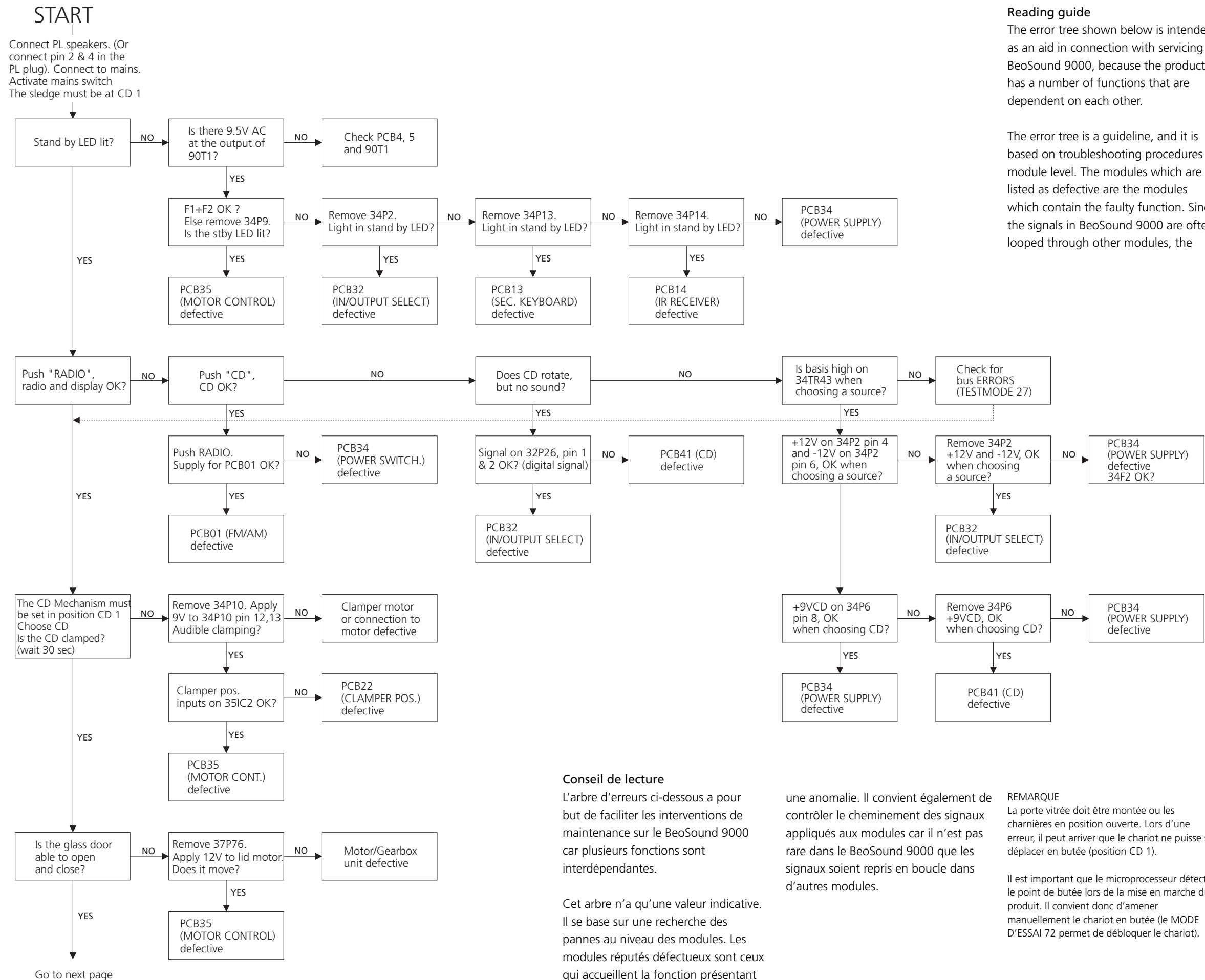

Reading guide

The error tree shown below is intended as an aid in connection with servicing BeoSound 9000, because the product has a number of functions that are dependent on each other.

The error tree is a guideline, and it is based on troubleshooting procedures at module level. The modules which are listed as defective are the modules which contain the faulty function. Since the signals in BeoSound 9000 are often looped through other modules, the

signal paths to the modules also have to be checked.

NOTE:
The glass lid must either be on, or the hinge for the lid must be in the open position. In a fault situation the sledge may be unable to move to its end stop (CD 1 position).

End stop detection is important for the microprocessor when powering up the product. Therefore the sledge should manually be brought to the end stop position (the sledge is released in TEST MODE 72).

Anleitung

Der unten gezeigte Fehlerbaum ist als eine Hilfe im Zusammenhang mit der Wartung des BeoSound 9000 gedacht, indem nämlich eine Reihe von Funktionen voneinander abhängig ist.

Der Fehlerbaum dient als Anleitung und basiert auf Fehlersuche auf Modulebene.

Die Module, die als fehlerhaft angegeben werden, sind die Module, auf denen sich die defekte Funktion untergebracht ist. Da die Signale im BeoSound 9000 oft durch andere Module hindurchgeschleift werden, sind die jeweiligen Signalwege zu den Modulen ebenfalls zu kontrollieren.

HINWEIS!
Entweder muß die Glastür montiert sein oder die Türscharniere müssen in Position 'offen' stehen. Bei Fehlern kann es vorkommen, daß sich der Schlitten nicht ganz bis zum Endschalter (CD 1 Position) bewegen kann.

Die Erkennung der Endschalterposition ist für den Mikroprozessor bei jeder Inbetriebnahme des Produktes wichtig. Deshalb muß der Schlitten evtl. von Hand zur Endschalterposition bewegt werden (der Schlitten wird in TEST MODE 72 gelöst).

Conseil de lecture

L'arbre d'erreurs ci-dessous a pour but de faciliter les interventions de maintenance sur le BeoSound 9000 car plusieurs fonctions sont interdépendantes.

Cet arbre n'a qu'une valeur indicative. Il se base sur une recherche des pannes au niveau des modules. Les modules réputés défectueux sont ceux qui accueillent la fonction présentant

une anomalie. Il convient également de contrôler le cheminement des signaux appliqués aux modules car il n'est pas rare dans le BeoSound 9000 que les signaux soient repris en boucle dans d'autres modules.

REMARQUE

La porte vitrée doit être montée ou les charnières en position ouverte. Lors d'une erreur, il peut arriver que le chariot ne puisse se déplacer en butée (position CD 1).

Il est important que le microprocesseur détecte le point de butée lors de la mise en marche du produit. Il convient donc d'amener manuellement le chariot en butée (le MODE D'ESSAI 72 permet de débloquent le chariot).

Go to next page

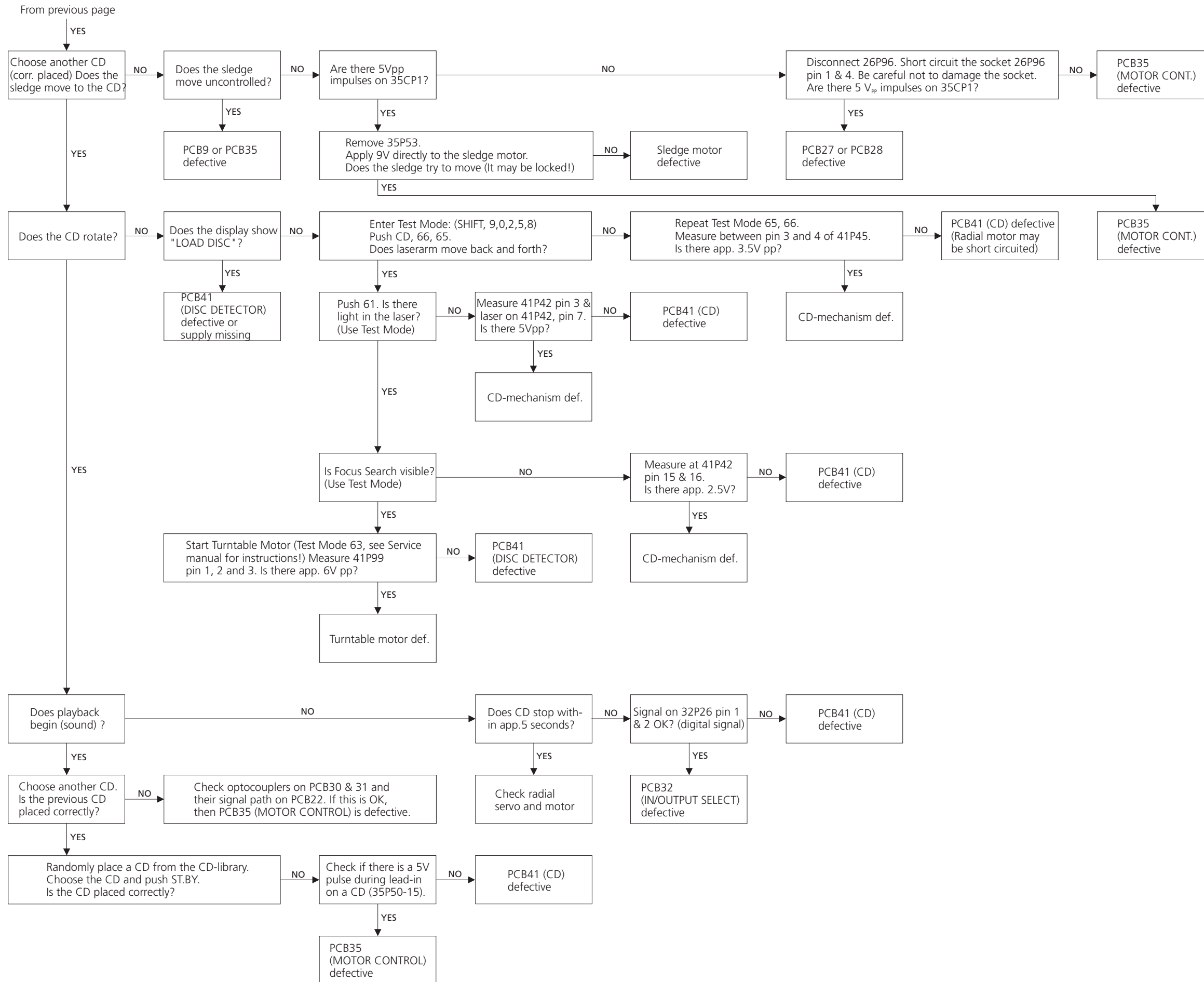

Dismantling and assembly

READING GUIDE

BeoSound 9000 has a high level of integration of mechanics and electronics. To achieve optimum servicing it is therefore important to follow these dismantling instructions carefully when servicing the product.

The dismantling instructions are divided into two main sections:

- a) A section that describes how to gain access to the individual modules. This section includes a description of the mechanical parts that have to be dismantled.
- b) A section that describes how to remove/dismantle the individual mechanical/ electrical parts:
 1. Glass lid
 2. Left aluminium plate
 3. Release of sledge
 4. Cover for chassis top plate
 5. Chassis top plate
 6. Cover for CD clamper
 7. Top plate for CD mechanism
 8. Clamper arm
 9. CD mechanism
 10. Top plate
 11. Sledge and ribbon cables
 12. Sledge motor and wires
 13. Gearbox
 14. Rear panel

Remember always to execute TEST MODES 71 + 73, after a repair. When the product has been assembled, check the finger protection system by interrupting the IR beam between the two "towers".

If the optocouplers in the product are affected by external light the product will not operate. If the optocouplers in the product are affected by external light the product will not operate.

ACCESS TO THE INDIVIDUAL MODULES

PCB1 FM/AM, RF IF Decoder

- Carry out points 1 to 5.
- Remove 35P53, power supply for sledge motor.
- Lift up the PCB for service.

PCB3 Main microcomputer

- See PCB34.

PCB4 Mains Filter

- Carry out points 1 to 5.
- Remove 35P53, power supply for sledge motor.
- The PCB is placed in service position.

PCB5 Mains Relay

- Carry out points 1 to 5.
- Remove 35P53, power supply for sledge motor.
- Remove the screw for the cover over PCB5. Take off the cover. Do not cut the Tyrap.
- Remove the leads in 5P82 and 5P84, and loosen the lead between 5P83 and 34P16. Make sure that the lead does not obstruct the wire.

PCB7 Display

- Carry out the points 1 and 6 to 8.
- If necessary, use one of the cables supplied at the back of the service manual during servicing. Connect it between 34P8 and 7P63.
- Please note that the sledge runs at high speed when switching among the individual CD's.

PCB9 Sledge Position

- Carry out points 1 to 5.
- Remove 35P53, power supply for sledge motor.
- The PCB is placed in service position.

PCB11 Main Keyboard, left

- Carry out point 10.
- The PCB can be lifted up.
- Remember the chassis spring when reassembling.

PCB12 Main Keyboard, right

- Carry out point 10.
- The PCB can be lifted up.
- Remember the chassis spring when reassembling.

PCB13 Secondary Keyboard

- Carry out points 1 to 5.
- Remove one screw on the PCB.

PCB14 IR Receiver

- Carry out points 1 to 5.
- Remove 35P53, power supply for sledge motor, and 26P96.
- Remove the screws for the top plate (C, D, E) (see under point 10), lift the top plate carefully (approx. 2 cm), and carefully pull the top plate a little to the right.
- Remove two screws for PCB14 and lift off the PCB.

PCB20 Master Link Interface

- See PCB32.

PCB21 Headphones

- Carry out points 1 to 5.
- Remove 35P53, power supply for sledge motor, and 26P96.
- Remove the screws for the top plate (C, D, E) (see under point 10), lift the top plate carefully (approx. 2 cm), and carefully pull the top plate a little to the right.
- Remove one screw. PCB21 can now be pulled up.
- When reassembling, make sure that the leads do not obstruct the sledge.

PCB22 Clamper Position

- Carry out point 14.

PCB24 Light indication right

- Carry out points 1 to 5.
- The diodes can be removed through the "front".
- The PCB is riveted to the chassis top plate and cannot be removed any further. If the PCB is removed, it MUST be fixed again with double-sided adhesive tape.

PCB25 Light indication left

- Carry out points 1 to 5.
- The diodes can be removed through the "front".
- The PCB is riveted to the chassis top plate and cannot be removed any further. If the PCB is removed, it MUST be fixed again with double-sided adhesive tape.

PCB26 End stop detector

- Carry out points 1 to 5.
- Remove 35P53, power supply for sledge motor.
- Remove 26P96 and 26P75. The PCB holder can now be lifted up.

PCB27 Safety TX

- Carry out points 1 to 8.
- Remove 35P53, power supply for sledge motor, and 26P96.
- Remove the screws for the top plate (see under point 10). Carefully pull the top plate towards the right. PCB27 is fixed under the top with a screw.

PCB28 Safety RX

- Carry out points 1 to 8.
- Remove 35P53, power supply for sledge motor, and 26P96.
- Remove the screws for the top plate (see under point 10). Carefully pull the top plate towards the right. PCB28 is fixed under the top with a screw.

PCB29 Lamp

- Carry out point 1 and the points 6 to 8.
- Remove one screw for the PCB.
- Please note that the sledge runs at high speed when switching among the individual CD's.

PCB30 IR transmitter, tacho clamper

- Carry out points 1 and 6 and 7.
- Remove PCB29 and push up the Tacho holder. It is now possible to unclip PCB30.
- Please note that the sledge runs at high speed when switching among the individual CD's.

PCB31 IR receiver, tacho clamper

- Carry out point 1 and points 6 to 8.
- Remove PCB29 and push up the Tacho holder. Push out the PCB via the two small holes from the opposite side of the Tacho holder.
- Please note that the sledge runs at high speed when switching among the individual CD's.

PCB32 Input/output Select and Sound adjustment

- Carry out points 1 to 5.
 - Remove 35P53, power supply for sledge motor.
 - Remove PCB1. Push in the clip on the right-hand side and lift up (at a slant) the PCB for service.
- P24, Headphones, may be removed if necessary.

PCB34 Microcomputer and Power Supply

- Carry out points 1 to 5.
- Remove 35P53, power supply for sledge motor.
- Remove the plastic screen over the flex cables from the sledge.
- Lift up PCB34 and PCB35 simultaneously - watch out for the flex cables. Lift up PCB34 and PCB35 at the rear edge of the product.
- When carrying out service, lift up PCB34 and PCB35 and place them against the rear edge of the chassis. Make sure that the wire is able to run.
- The connection between 9P78 and 35P52 can be re-established by means of the cable supplied in the plastic pocket at the very back of the service guide.
- When returning PCB34 and PCB35 to their places, make sure that no leads get jammed.

PCB35 Motor control

- See PCB34.

PCB37 Lid Motor

- Carry out point 13.
- Unsolder the leads for the motor.
- Remove three screws on the flange with the motor.

PCB41 CD

- Carry out points 1 to 8.
- Remove 35P53, power supply for sledge motor.
- Remove the two screws for the cover for the CD PCB.
- Remove the two screws that hold PCB41, CD, and tilt PCB41 over to the side.
- Make sure that the ribbon cables do not get into contact with the CD.
- Push the sledge into position.

MECHANICAL/ELECTRICAL DISMANTLING**1. Glass lid**

- Open the glass lid. The lid can be forced up if necessary.
- Disconnect the mains voltage.
- First loosen the screw on the left-hand side (approx. 3 turns).
- Hold the left-hand side of the glass while loosening the screw on the right-hand side.
- Lift off the glass.
- Tighten the screws again, otherwise the screws will damage the top plate when the lid function is activated.
- WHEN THE GLASS LID HAS BEEN REMOVED THE SLEDGE IS ONLY ABLE TO RUN WHEN THE LID HINGES ARE IN THE OPEN POSITION. (SEE TEST MODE 74, IF REQUIRED).
- Check finger protection after assembly.

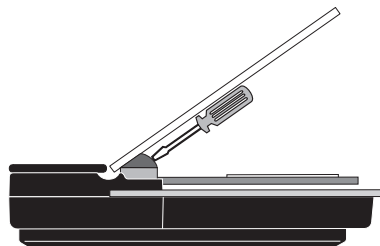
Fig. 1

2. Left aluminium plate (grooved profile)

- Lift the front edge on the left-hand side, push the plate to the left (it fits tightly), and lift it off.

Fig. 2

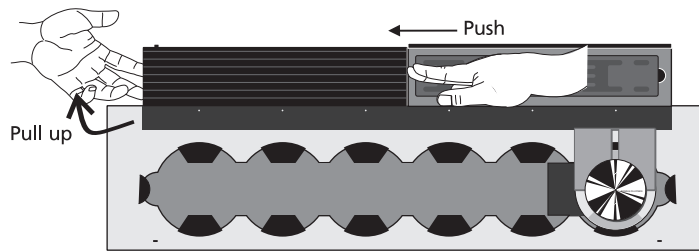

3. Release of sledge

- The sledge can be released in four different ways:
 - a) With the product switched on.
 - Carry out point 1.
 - Carry out test mode 72 (CD72, see TESTMODES page 5.13).
 - b) If the product cannot be switched on.
 - Turn the big gearwheel under the sledge (in the middle on the left-hand side) clockwise. Use a screw driver, if necessary (be careful not to scratch the bottom), Fig. 3.
 - Or point c.
 - c) If the product cannot be switched on and the sledge is placed in positions 5 or 6.
 - Carry out points 6 to 8.
 - Remove the two screws for the cover for the CD PCB. Remove the cover by pulling it to the left.
 - Remove the plug for the clamper motor (41P45).
 - The clamper motor terminals are now accessible. Apply +9V DC. The sledge will now be released.
 - d) If the sledge is placed in position 6 and cannot be moved.
 - Remove the rear panel of the product, see point 14. The sledge is released by turning the big gearwheel.

Fig. 3

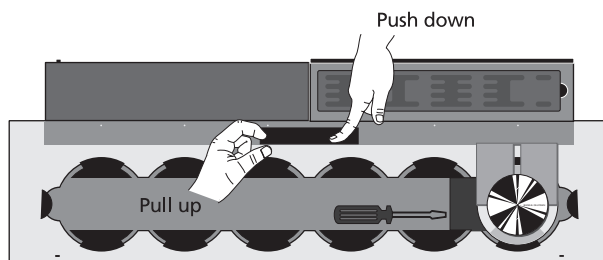

4. Cover for chassis top plate

- Carry out points 1 to 3.
- Push down the cover, tilt it out, and take it up, Fig. 3.
- Push the sledge into the notch that has been created.

5. Chassis top plate

- Carry out points 1 - 4.
- Switch off the product.
- Lift out the operating panel, and remove the nine screws marked A.
- Lift up and tilt backwards.

Fig. 4

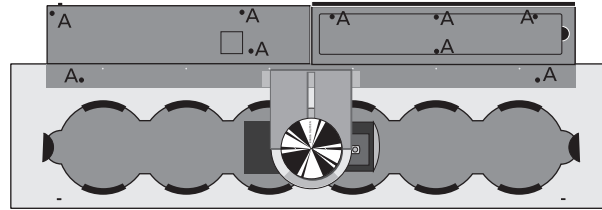

6. Cover for CD clamper

- Turn the cover until BANG & OLUFSEN is aligned with the hole, and then lift it off, see Fig. 4.

7. Top plate for CD mechanism

- Carry out point 1 and point 6.
- Lift off the plate (it has some small barbs that hold it back).

8. Clamper arm

- Carry out point 1 as well as points 6 and 7.
- Remove the three screws marked B and two flat springs.
- Loosen 7P62 and 7P63.
- Push down the clamper holder and then lift.

Fig. 5

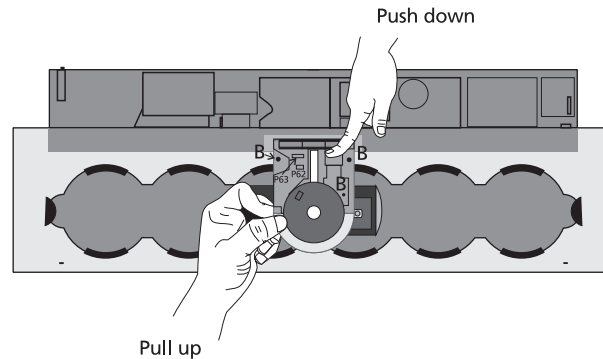

9. CD mechanism

- Carry out points 1 and 3 as well as points 6 to 8.
- Remove two screws from the cover over the CD mechanism.
- Lift the cover on the left-hand side and push it towards the right.
- Remove the two screws (C) for the cover of the CD PCB. Remove the cover by pulling it towards the left.
- Remove two screws for PCB41, CD.
- Lift up PCB41 a little and remove P99.
- Remove one screw for the bracket on the CD mechanism.
- Remove the four screws (D) that hold the CD mechanism.
- Lift up the CD mechanism a little and loosen the flex cable. Watch out for the flex cable under the CD mechanism; the cable runs under the arm for the tension springs.

Fig. 6

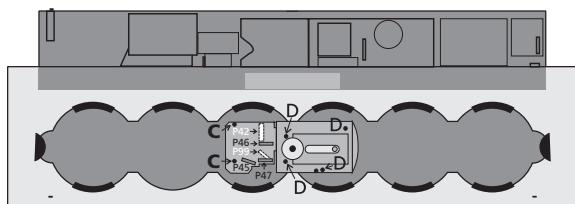

10. Top plate

- Carry out the points 1 to 8.
- Remove 35P53, power supply for sledge motor.
- Remove two screws (E) for the clammer holder, and remove the holder, Fig. 8.
- Remove the six plugs with a thin hook or a similar object.
- Remove the six screws in the bottom (F), and loosen the two screws (G) (approx. six turns), Fig. 7.
- PLACE THE SLEDGE AT THE CENTRE.
- Loosen 26P96.
- The top can now be removed by pulling it towards the right while holding the sledge. It will be released from the sledge automatically when it reaches the end.
- LIFT THE TOP PLATE AS LITTLE AS POSSIBLE AND VERY CAREFULLY IN ORDER TO AVOID DAMAGING THE RIBBON CABLE AND STEEL BAND FOR THE SLEDGE.
- IT IS IMPORTANT TO HOLD ON TO THE SLEDGE. THE WIRE SYSTEM HAS BEEN "TIGHTENED" SO THAT IT IS VERY TIGHT.
- Remove the plastic strip over the well containing the ribbon cables and the wires by lifting up the strip.
- Place the sledge at the centre of the product.
- Instal the red holder on the bracket for wires/cable, Fig. 9.
- Loosen the spring on the right-hand side of the product, if necessary. The spring is very tight. Be careful not to let the sledge turn around.

Fig. 7



Fig. 8

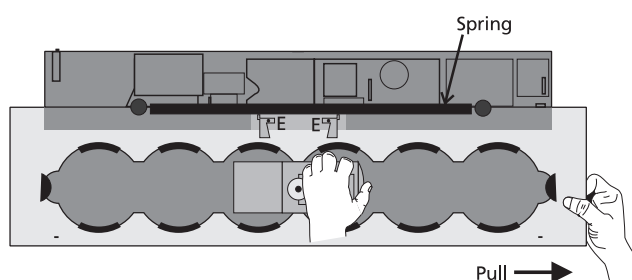

11. Sledge and ribbon cables

- Carry out the points 1 to 8, and remove the screws for the top plate (C, D, E), see point 10.
- Remove the plastic strip over the well containing the ribbon cables and the wires by lifting up the strip.
- Instal the red holder on the bracket for wires/cable, Fig. 9.
- Remove two screws from the cover over the CD mechanism.
- Lift the cover on the left-hand side and push it towards the right.
- Remove the two screws for the cover for the CD PCB. Remove the cover.
- Loosen 41P46 and 41P47, Fig. 6.
- Remove 35P53, power supply for the sledge motor.
- Remove three screws (H) for the bracket for wires/cable, Fig. 9.
- Loosen 26P96.
- Lift up the top plate with the sledge carefully. Look out for the lead and ribbon cables.
- Place a holder, perhaps a Tyrapp, around the wire drive by the motor.
- Loosen the spring on the right-hand side of the product. The spring is very tight. Be careful not to let the sledge turn around.
- When the reassembly has been completed the sledge must not catch when it is moved while it is being pushed down at the same time.

Fig. 9

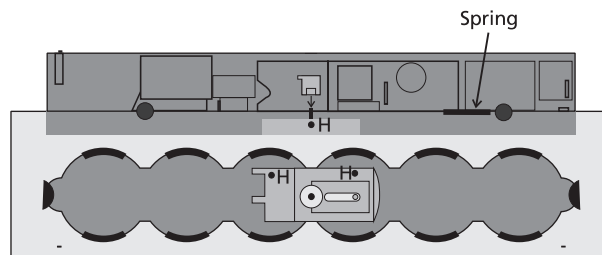

12. Sledge motor and wire drive

- Carry out point 11.
- Remove the wires from the sledge.
- Remove three screws and lift up the motor section.
- Watch out for the tachometer disc.
- Assembly, if necessary see pictures on page 5.19.

13. Gearbox

- Carry out the points 1 - 5.
- Remove four screws. The gearbox can now be lifted out.
- Remember to instal the chassis spring when the product is reassembled. The pointed end must be facing the top plate.

14. Rear panel

- Remove twelve screws (J) and lift it off. Watch out for the 8 ground connections .
- When the rear panel is installed the product must not be upside down. Place it in upright position, for example.

Fig. 10



Insulation test

Each set must be insulation tested after having been dismantled. Make the test when the set has been reassembled and is ready to be returned to the customer.

Flashovers must not occur during the testing procedure!

Make the insulation test as follows:

Short-circuit the two pins of the mains plug and connect them to one of the terminals of the insulation tester. Connect the other terminal of the insulation tester to ground on the FM-aerial socket.

NOTE!

To avoid damaging the set it is essential that both terminals of the insulation tester have good contact.

Slowly turn the voltage control of the insulation tester until a voltage of 2.5kV is obtained. Maintain that voltage for one second, then slowly turn it down again.

During the testing the current must not exceed 10 mA.

Isolationsprüfung

Nach einer Zerlegung ist bei jedem Gerät eine Isolationsprüfung vorzunehmen. Die Prüfung wird dann ausgeführt, wenn das Gerät wieder vollständig zusammengebaut und zur Auslieferung an den Kunden bereit ist.

Überschläge dürfen während der Prüfung nicht vorkommen!

Die Isolationsprüfung in folgender Weise durchführen:

Die beiden Steckerstifte am Netzstecker kurzschließen und an eine der Anschlußklemmen des Isolationsprüfers anschließen. Die andere Anschlussklemme des Isolationsprüfers an die Masse des FM-Antennenanschlusses anschließen.

ACHTUNG!

Um Beschädigungen des Gerätes zu vermeiden, ist es wichtig, daß beide Anschlußklemmen des Isolationsprüfers einen sehr guten Kontakt haben.

Die Spannungsregelung des Isolationsprüfers langsam nach oben drehen, bis eine Spannung von 2,5kV erreicht wird. Diese Einstellung 1 Sekund aufrechter-halten, und anschließend die Spannung wieder langsam nach unten drehen.

Der Strom darf während der Prüfung nicht 10 mA übersteigen.