

# Bang & Olufsen

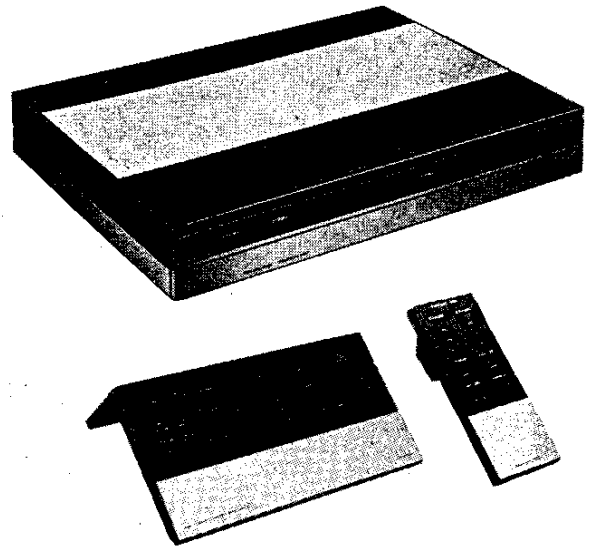

## **Beomaster 5000**

Type 2321-2322-2323-2324-2325-2329

## **Master Control Panel**

Type 2038

## **Master Terminal**

Type 2039

FOR SERVICE MANUALS  
CONTACT:  
**MAURITRON TECHNICAL SERVICES**

[www.mauritron.co.uk](http://www.mauritron.co.uk)

TEL: 01844 - 351694

FAX: 01844 - 352554



*mPC*

## INDHOLD

Betjeningsanvisning, diagrammer og PCB plader .....	1
Halvlederoversigt .....	2
Elektrisk stykliste .....	3
Mekanisk stykliste .....	4
Elektrisk justering .....	5
Tekniske data .....	6
Adskillelse .....	7
Servicetips og modifikationer .....	8
Isolationstest .....	9
Slutafprøvning .....	10

## CONTENTS

Operating manual, circuit diagrams and PCB boards .....	1
Semi-conductors .....	2
Electrical parts list .....	3
Mechanical parts list .....	4
Electrical adjustment .....	5
Technical data .....	6
Dismantle .....	7
Service tips and modifications .....	8
Insulation test .....	9
Final test .....	10

FOR SERVICE MANUALS  
CONTACT:  
**MAURITRON TECHNICAL SERVICES**  
[www.mauritron.co.uk](http://www.mauritron.co.uk)  
TEL: 01844 - 351694  
FAX: 01844 - 352554

### INTRODUKTION

Beosystem 5000 består af Master Control Panel 5000 (MCP 5000) Beomaster 5000, Beocord 5000 og Beogram 5000.

MCP 5000 er den enhed i Beosystem 5000, som samler enhederne og gør den til et hele. MCP 5000 kommunikerer på infrarød basis med Beomaster 5000, hvorfra kommunikationen med resten af systemet foregår via en data link.

### INTRODUCTION

Beosystem 5000 is made up of Master Control Panel 5000 (MCP 5000), Beomaster 5000, Beocord 5000 and Beogram 5000.

MCP 5000 is the unit in Beosystem 5000 which combines the units and makes them an entity. MCP 5000 communicates on an infrared basis with Beomaster 5000 which then communicates with the remainder of the system via a data link.

Designmæssigt er MCP 5000 udformet, således at topbetjeningens fordele fuldt ud kommer til sin ret, i modsætning til de øvrige enheder i systemet, hvor hovedvægten designmæssigt er lagt på de placeringsmæssige muligheder, hvilket giver frontbetjening.

MCP 5000 er Bang & Olufsen's fjernbetjeningspanel nummer 2, som giver visuel tilbagemelding om systemets aktuelle status.

MCP 5000 giver i forhold til Beocenter 7700's Master Control Panel en endnu højere grad af betjeningens komfort, idet samtlige funktioner (bortset fra handling af plader og bånd) i hele Beosystem 5000 kan betjenes herfra.

Beomaster 5000 er det første Bang & Olufsen produkt, som har indbygget automatisk opsøgning af AM og FM stationer.

Beomaster 5000 har indbygget memory for lagring af indtil 9 stationer (forvalg), AM eller FM i det ønskede mix. Indikation af program frekvens og volume foregår på ciffer display.

Betjeningstasterne, der normalt er skjult bag frontpanelet, kan vippes ud, således at en stor part af produktets funktioner kan betjenes herfra, men den komplette udnyttelse af Beomaster 5000 (Beosystem 5000) fås kun ved betjening via MCP 5000.

Beocord 5000 har, i forhold til tidligere båndoptagere fra Bang & Olufsen, indbygget et søgesystem, som arbejder med pauserne mellem optagelserne. Systemet kan opsøge indtil 8 pauser frem eller tilbage på båndet.

Beocord 5000 har endvidere et løbeværk med kurvehjulscontrolleret »afdæmpning« af indkoblingen af tonehovedbroen og spolefunktionerne.

Beocord 5000 er opbygget med en »skuffe«, som glider frem ved hjælp af en motor, når der skal skiftes/ilægges bånd.

Hovedparten af båndoptagerens funktioner kan betjenes direkte på skuffens panel, når skuffen er kørt frem, Play kan endvidere betjenes på frontens højre side uden aktivering af »skuffen«.

Beogram 5000 er en videreudvikling af Beogram 1800.

Beogram 5000 har indbygget en repeat funktion med tilhørende indikator. Repeat funktionen kan »huske« indtil 7 repeat indtastninger.

Denne serviceanvisning er gældende for MCP 5000 og Beomaster 5000.

Beocord 5000 og Beogram 5000 forefindes i separate serviceanvisninger.

MCP 5000 is designed in such a way that the advantages of the topside operation are fully utilized as opposed to the other units of the systems where designwise most considerations have been given to the location options which have resulted in frontal operation.

MCP 5000 is Bang & Olufsen's remote control panel No. 2 and it provides a visual feedback on the actual status of the system.

As compared with the Master Control Panel of Beocenter 7700, the MCP 5000 affords an even higher degree of operational comfort since all functions (apart from handling of records and tapes) of the complete Beosystem 5000 can be controlled from MCP 5000.

Beomaster 5000 is the first Bang & Olufsen product to have integrated automatic search of AM and FM stations.

Beomaster 5000 has integrated memory for storing of up to 9 stations (pre-selection), AM or FM in the mix required. Programme, frequency and volume are indicated on a digital display.

The operational keys which are normally concealed behind the front panel, are tiltable outwards so that a considerable part of the functions of this system can be operated from this location, but the full utilization of Beomaster 5000 (Beosystem 5000) is only achievable by operation via MCP 5000.

Compared with earlier Bang & Olufsen tape recorders Beocord 5000 has an integrated search system which inserts pauses between the recordings.

The system is capable of searching up to 8 pauses forwards or backwards on the tape.

Furthermore, Beocord 5000 has a drive train with camwheel controlled »damping« of the engagement of the tape head bridge and the coil functions.

Beocord 5000 has a »drawer« with a motordriven forward motion for tape changing/loading.

It is possible to operate the main part of the functions of the tape recorder direct on the drawer panel when the drawer is in its forward position. Furthermore, Play is operable on the right side of the front without activation of the »drawer«.

Beogram 5000 is a further development of Beogram 1800.

Beogram 5000 has an integrated repeat function with associated indicator. The repeat function is able to »remember« up to 7 repeat entries.

This service manual applied to MCP 5000 and Beomaster 5000.

Beocord 5000 and Beogram 5000 have separate service manuals.

- 1 AM/FM ..... diagr. A
- 2 Output Amplifier and Power ..... diagr. B
- 3 Preamplifier ..... diagr. B-C
- 4 Microcomputer ..... diagr. C
- 5 Keyboard ..... diagr. C
- 6 Fan-regulation ..... diagr. B
- 7 Display-Right ..... diagr. C
- 8 Display-Left ..... diagr. C
- 9 Remote control ..... diagr. C
- 10 RF Level adjustment ..... diagr. A
- 11 Master Control, Keyboard ..... diagr. D
- 12 Master Control, Microcomputer ..... diagr. D
- 13 Master Control, IR-Left ..... diagr. D
- 14 Master Control, IR-Right ..... diagr. D
- 16 Master Terminal, Microcomputer ..... diagr. E
- 17 Master Terminal, Keyboard ..... diagr. E

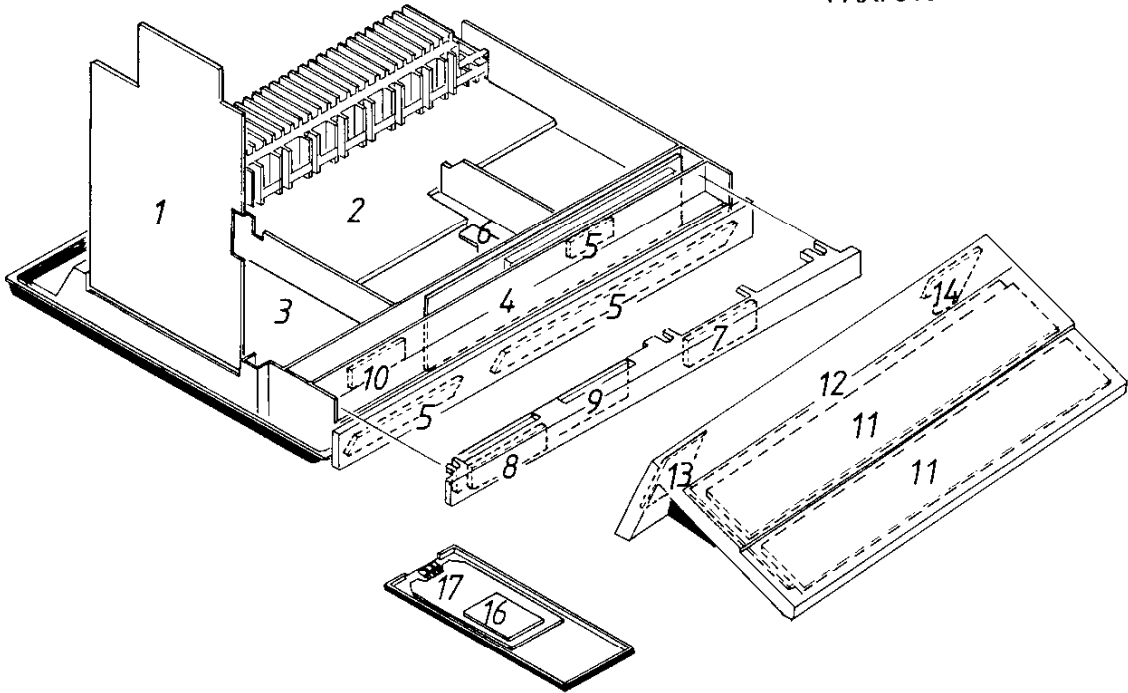
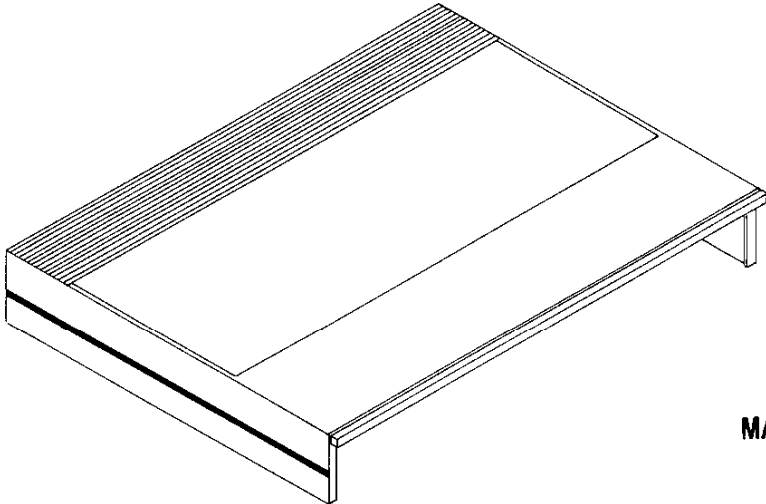

FOR SERVICE MANUALS  
CONTACT:  
**MAURITRON TECHNICAL SERVICES**  
[www.mauritron.co.uk](http://www.mauritron.co.uk)  
TEL: 01844 - 351694  
FAX: 01844 - 352554

# 1-3

## Operating Manual for Beomaster 5000

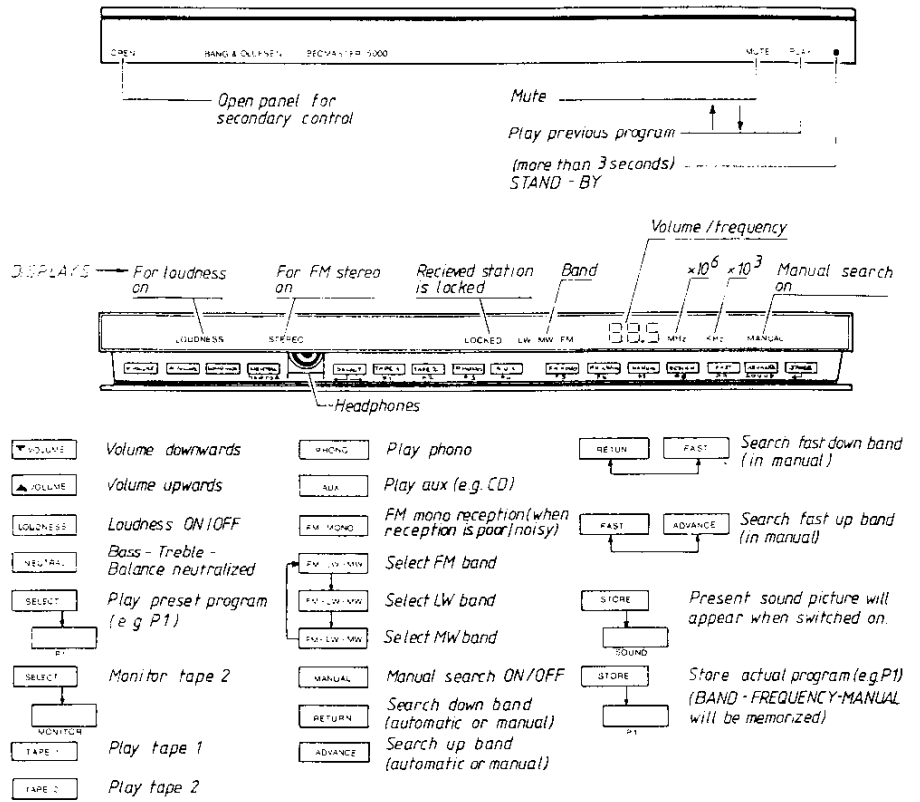

## Operating Manual for Master Control Panel

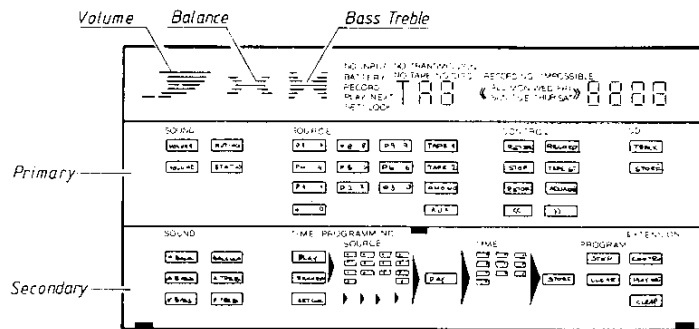

### PRIMARY CONTROL

#### SOUND:

- Volume upwards
- Volume downwards
- Sound instant OFF - ON
- Display actual function

#### SOURCE:

- Select preset FM/AM station
- Select preset FM/AM station
- PLAY taperecorder connected TP1
- PLAY taperecorder connected TP2
- PLAY recordplayer connected PH
- PLAY recordplayer (CD) connected AUX
- STAND BY

#### CONTROL:

Green buttons for record - functions

- Recording possible (pause)
- Recording
- Pause (4 sec. pause on tape)
- Recording possible OFF
- Fast rewind to startposition of sequence

White buttons influence source chosen

- Autosearch backwards (AM-FM-TP-CD)
- Autosearch forwards (AM-FM-TP-CD)
- AM/FM: Autosearch from bottom of opposite band  
TAPE: Fast forward  
CD: Move pick-up forward
- AM/FM: Autosearch from top of opposite band  
TAPE: Fast rewind  
CD: Move pick-up backward
- Stops searchfunctions

#### CD:

- Open for track sequence selection
- Select track 12
- Memorize 12 as next in sequence

### SECONDARY CONTROL

#### SOUND:

- Balance towards left
- Balance towards right
- Bass upwards
- Bass downwards
- Treble upwards
- Treble downwards

#### TIME PROGRAMMING

- Open for clock set
- Select actual day by stepping
- Select actual time (eg. 8.30)
- Memorize time setting
- Select function of time - if memory is occupied NO INPUT is displayed
- Source selection
- Select day by stepping
- Select time (eg. 7.00)
- Memorize time programming (one out of a capacity of 12)
- Recalls and displays programmes one by one stepping - After last program the display will be NO INPUT.
- Remove displayed program from memory

#### EXTENSION

- You can control tape or disc without influencing source
- eg. TAPE 2
- Tape 2 is rewinding
- Event programming is possible (after any auto stop)
- P3 is played after tape auto stop - You can select any source you want
- Remove play next function
- Remove play next function

#### STORE AM/FM FREQUENCIES:

- 
- 
- 

#### STORE SOUND:

- 
- 
- Or treble or bal.

## DIAGRAMFORKLARING

På diagrammet er der angivet typenumre på transistorer og IC'er i de tilfælde hvor typenummeret er entydigt for komponentes placering i kredsløbet – f.eks. TR20/BC 557B.

Hvis positionsnummeret er efterfulgt af en stjerne skal reservedelsnummeret benyttes, da denne komponent er specielt udvalgt – f.eks. TR102\*.

### Koordinatnumre

De tre største PC plader er forsynet med et koordinatsystem. Komponenterne på disse PC plader er forsynet med et koordinatnummer på diagrammet (mindre skrifttype end positions nr.), som fortæller hvilket koordinat, på PC pladen, de er placeret i. Koordinatnumre for udgangsforstærkerens venstre kanal er angivet i parenteser i diagrammet for højre kanal.

### Styrekredsløb

I visse styrekredsløb er den aktive tilstand angivet med en bogstavsbetegnelse (Cr = High med CrO<sub>2</sub> bånd). Hvis betegnelsen er forsynet med negationstegn er den aktive tilstand LOW ( $\bar{C}r$  = LOW med CrO<sub>2</sub> bånd).

### Ledningsforbindelser

Ledningsforbindelserne på diagrammet er samlet i »bundter«. De enkelte ledninger er forsynet med koder, der fortæller hvortil de går.

#### INTERN FORBINDELSE PÅ EN DIAGRAMSIDE



Interne forbindelser på en diagramside angives med et tal. Knækket på ledningen viser i hvilken retning den anden ende af ledningen findes.

#### FORBINDELSE TIL EN ANDEN DIAGRAMSIDE

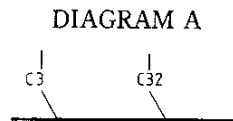

Forbindelsen til en anden diagramside angives med et tal, samt bogstav indikation på det diagram forbindelsen går til.

#### Symbol for sikkerhedskomponenter

Ved udskiftning af komponenter med dette symbol skal der anvendes komponenter med samme reservedelsnummer. Den nye komponent skal monteres på samme måde som den udskiftede.

## EXPLANATION OF DIAGRAM

Type numbers of transistors and IC's have been indicated on the diagram in those cases where the type number is unambiguous for the position of the component in a circuitry – e.g. TR20/BC 557B.

If the position number is followed by an asterisk the spare part number **must be used** because this component has been especially selected – e.g. TR102\*.

### System of Coordinates

The biggest PCB boards are provided with co-ordinate systems. The components on these PCB boards are provided with a co-ordinate number on the diagram (smaller printing type than the position numbers) indicating in which co-ordinate they are placed on the PCB board. The co-ordinate numbers for the left channel of the output amplifier are stated in brackets in the diagram for right channel.

### Control Circuit

In certain control circuits the active mode has been indicated by means of a letter symbol (Cr = HIGH with CrO<sub>2</sub> tapes). If the symbol has a negation superscript bar the active mode is LOW ( $\bar{C}r$  = LOW with CrO<sub>2</sub> tapes).

### Wiring Connections

The wiring connections on the diagram are assembled in »bundles«. The individual wires are coded to indicate to where they are leading.

#### INTERNAL CONNECTION ON ONE DIAGRAM PAGE

Internal connections on a diagram page are indicated by a number. The bend of the wire indicates in which direction the other end of the wire may be found.

#### CONNECTION TO ANOTHER DIAGRAM PAGE

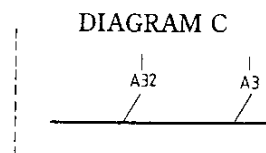

Connections to another diagram page are indicated by a number, as well as by a letter of the diagram to which the connections lead.



#### Symbol for Safety Components

When replacing components with this symbol components with identical part numbers are to be used. The new component must be fitted in the same way as the one replaced.

**MÅLEBETINGELSER**

Alle DC spændinger er målt til stel med voltmeter (indre modstand 10 Mohms).

DC spændinger er opgivet i volt (V). Eks. 0,7 V.  
Spændinger på diagram A er målt i stilling FM og ca. 1 mV signal, spændingerne i parentes er målt i stilling MW.

Spændinger på diagram B er målt med 1 W udgangseffekt.

Signalveje er vist for henholdsvis FM, AM, fjernbetjening og for LF højre kanal.

**MEASURING CONDITIONS**

All DC voltages are measured in relation to chassis with a voltmeter (internal resistor 10 Mohms).

DC voltages are stated in volts (V). E.g. 0.7 V.  
Voltages in diagram A are measured in FM mode and with approx. 1 mV signal, the voltages in parentheses are measured in MW mode.

Voltages in diagram B are measured with 1 W output level.

The signal paths are shown for FM, AM, remote control and AF right channel.

Type 2323 Explanation of the fuse symbols used in the set.  
Explanation de symboles du fusible utilisés dans l'appareil.



Replace with same type 5 ampere 250 volts slow acting fuse.

Remplacer par un fusible de meme type retardé et de 5 amperes 250 volts.

**FOR SERVICE MANUALS**

**CONTACT:**

**MAURITRON TECHNICAL SERVICES**

[www.mauritron.co.uk](http://www.mauritron.co.uk)

TEL: 01844 - 351694

FAX: 01844 - 352554



# Bang & Olufsen

Plug Survey

FOR SERVICE MANUALS  
CONTACT:  
**MAURITRON TECHNICAL SERVICES**  
www.mauritron.co.uk  
TEL: 01844 - 351694  
FAX: 01844 - 352554

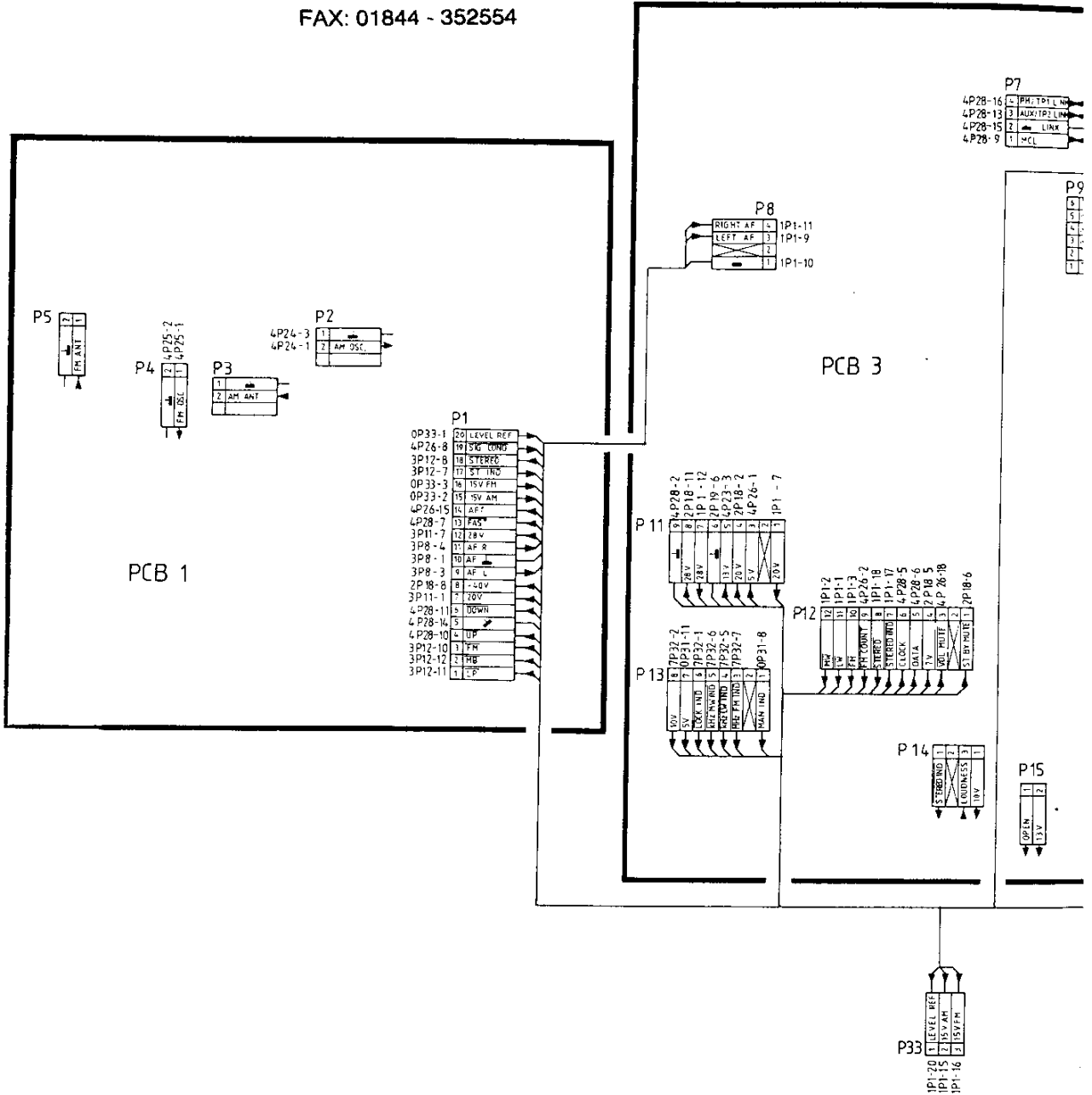

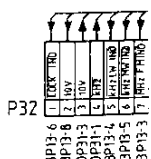
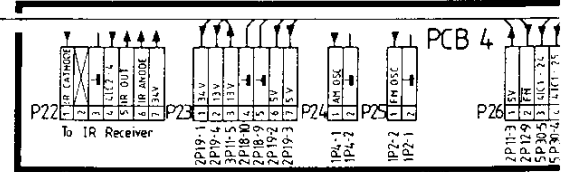
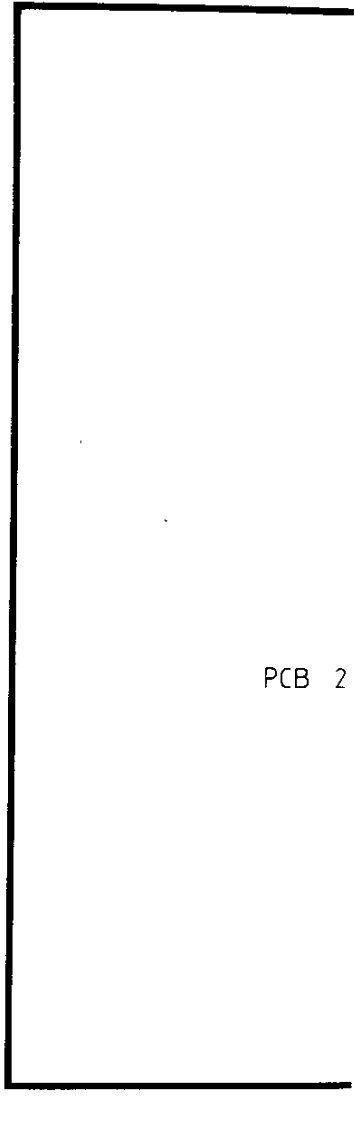
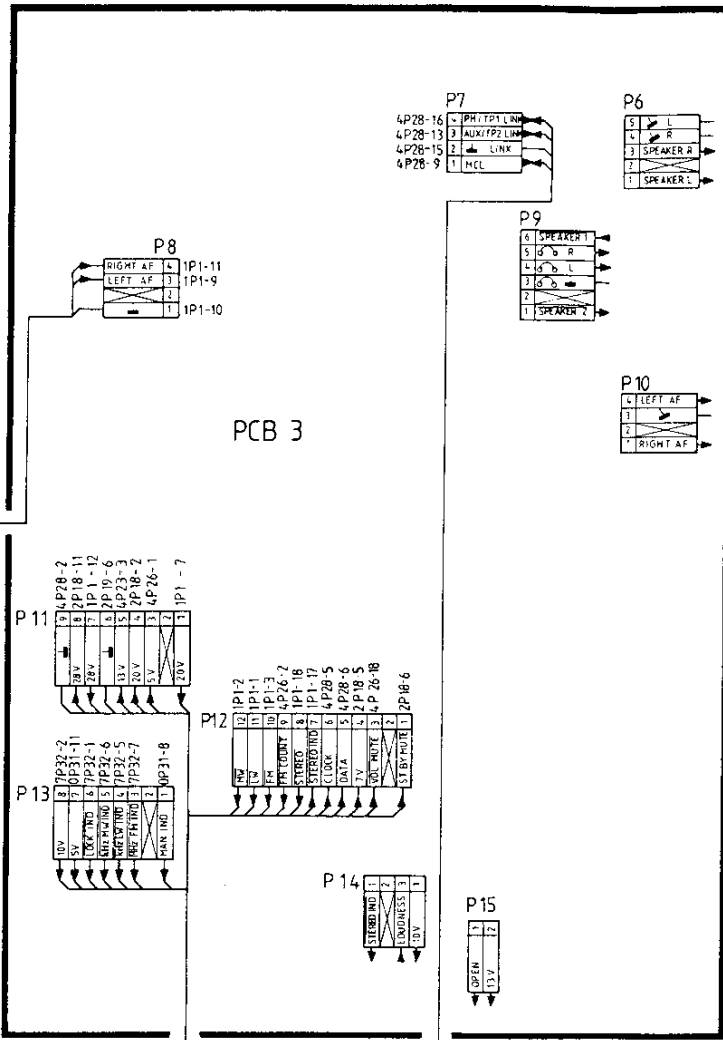
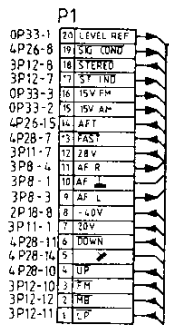

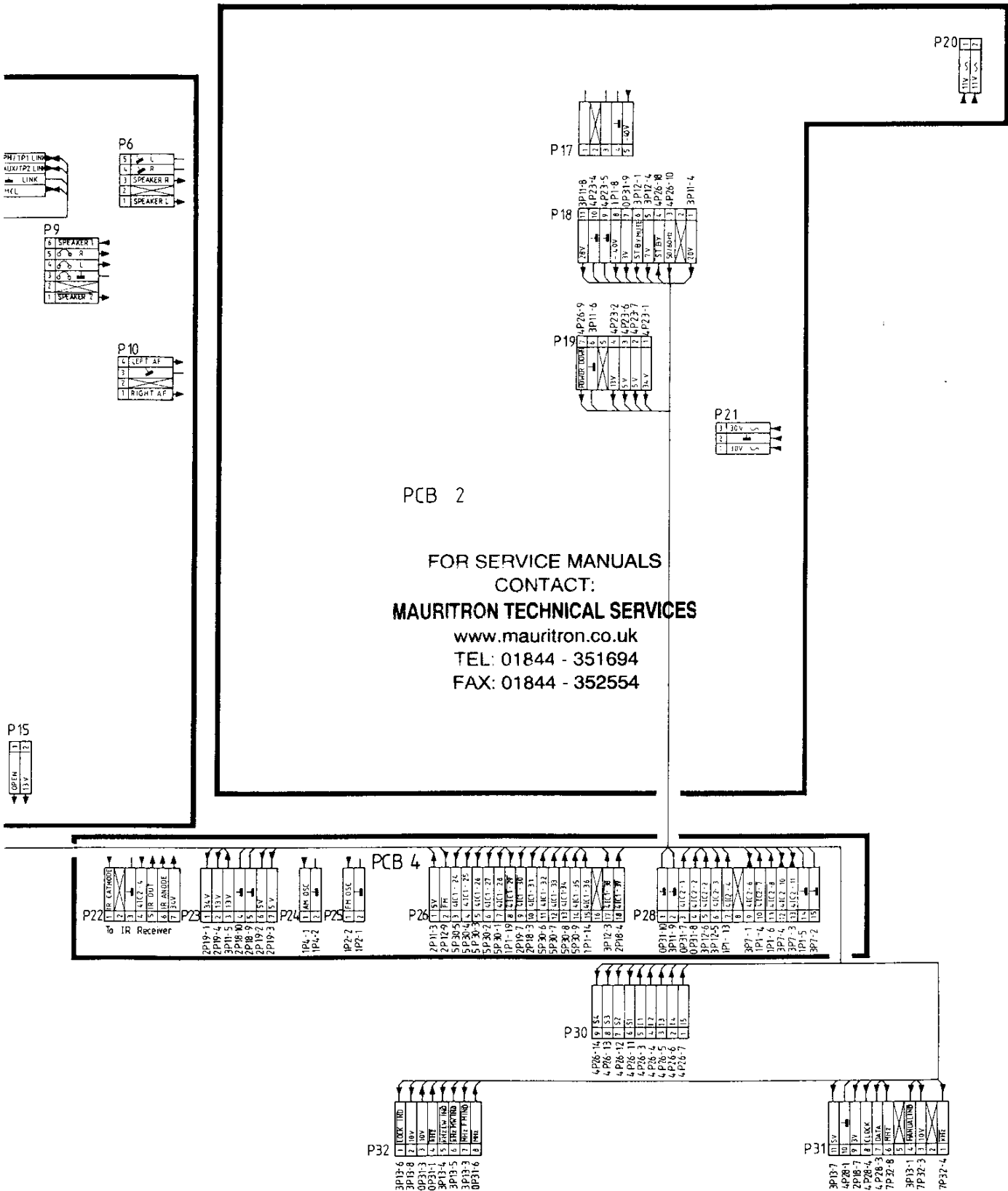

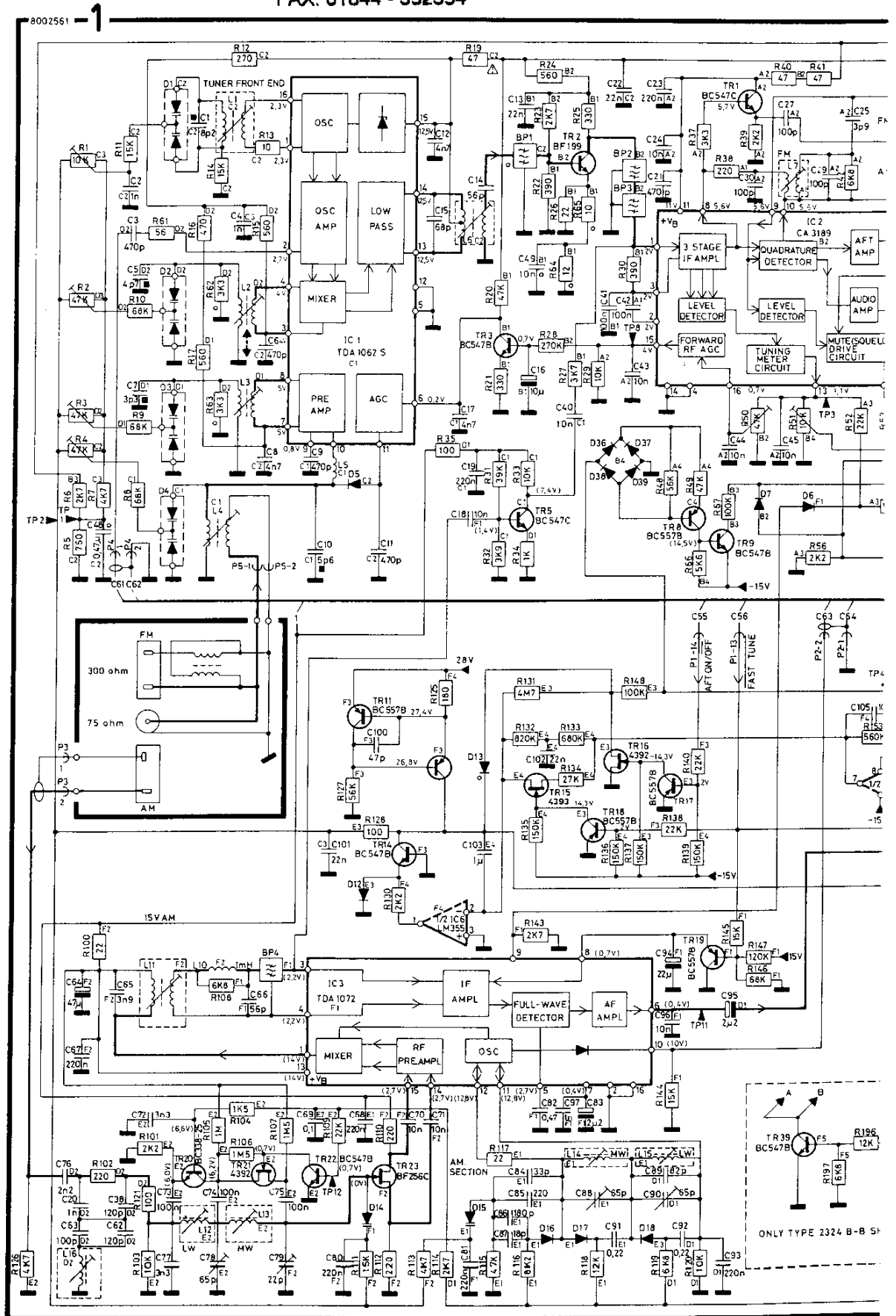

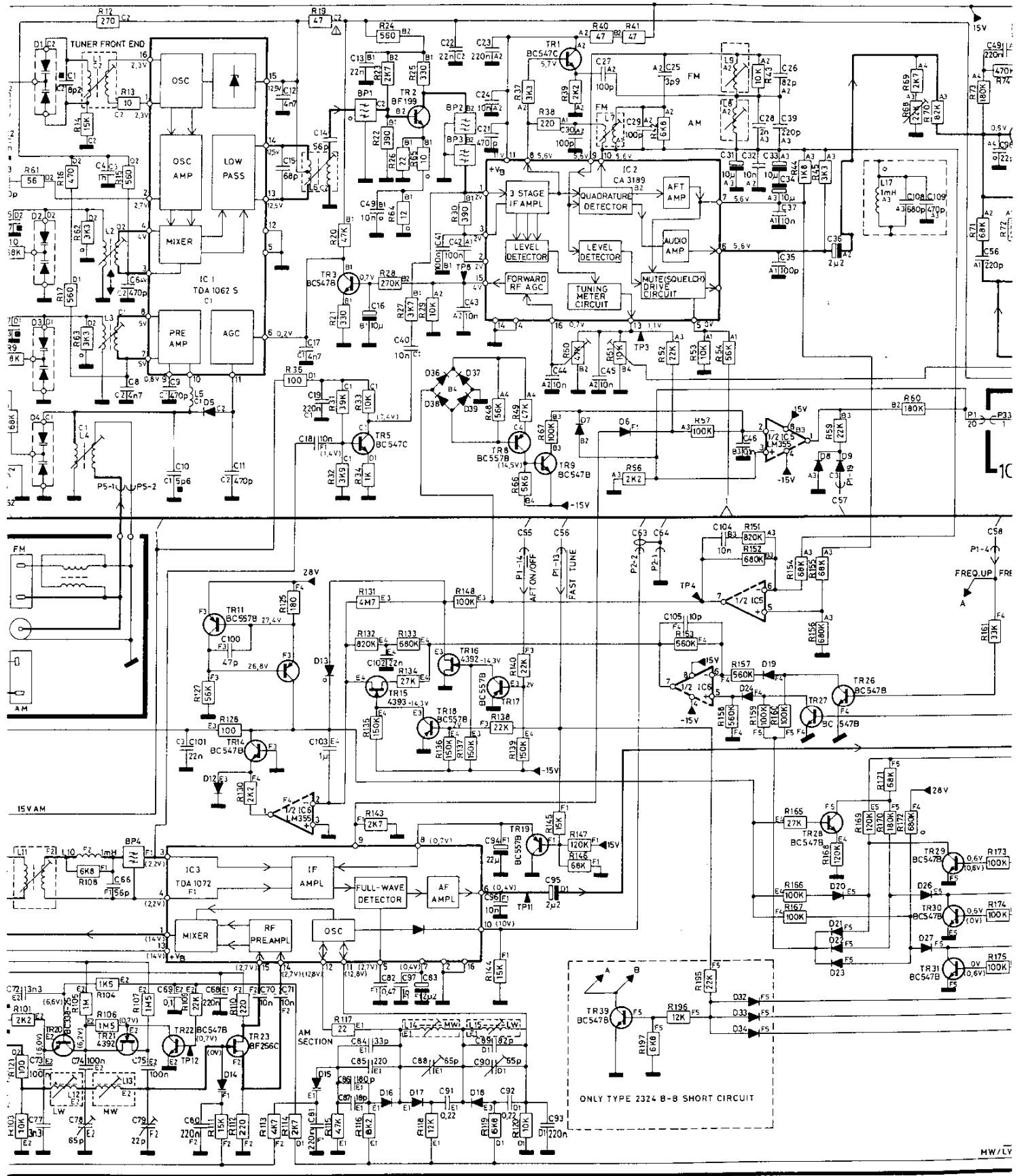

ONLY TYPE 2324 B-B SHORT CIRCUIT

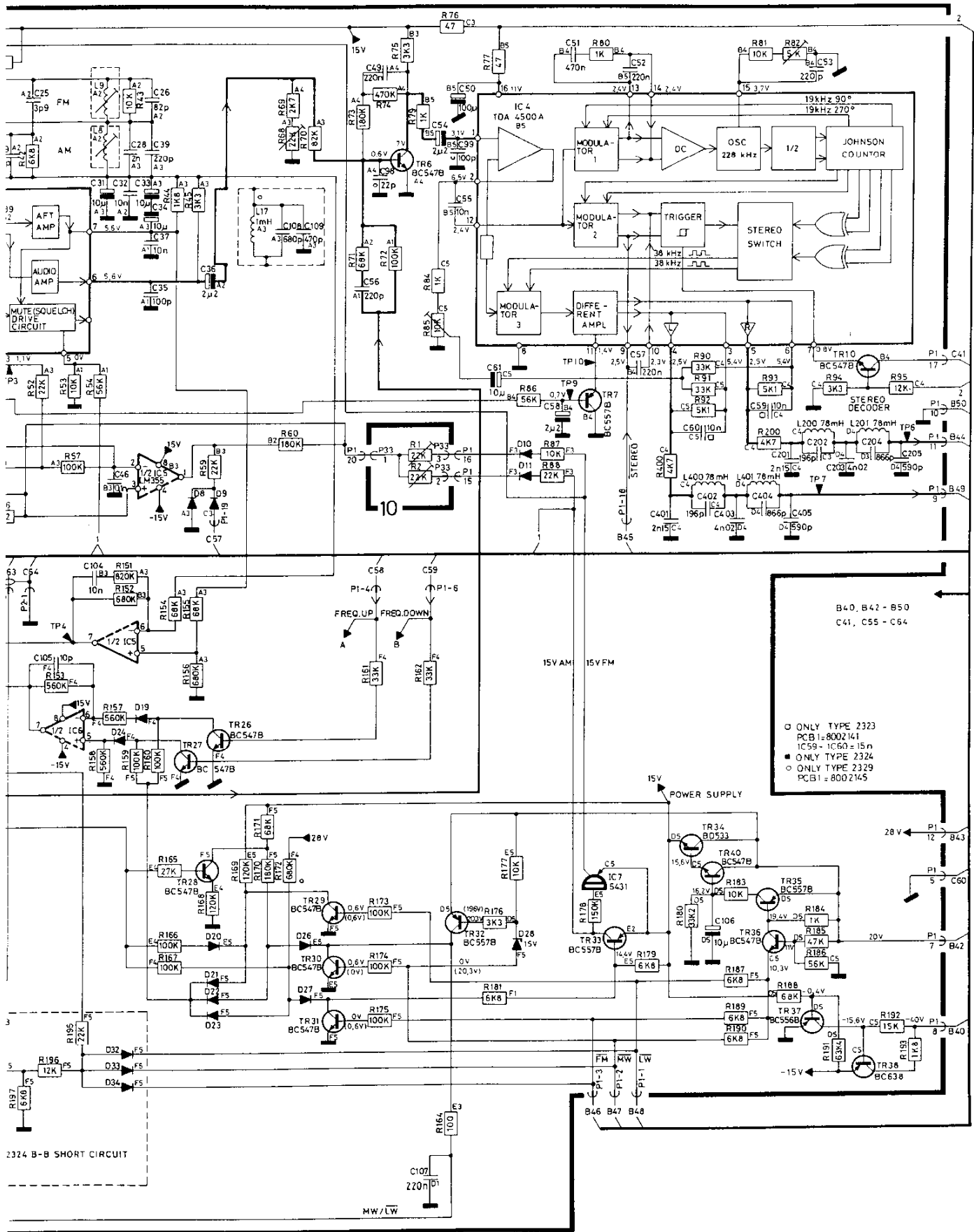

# Bang & Olufsen

Diagram B

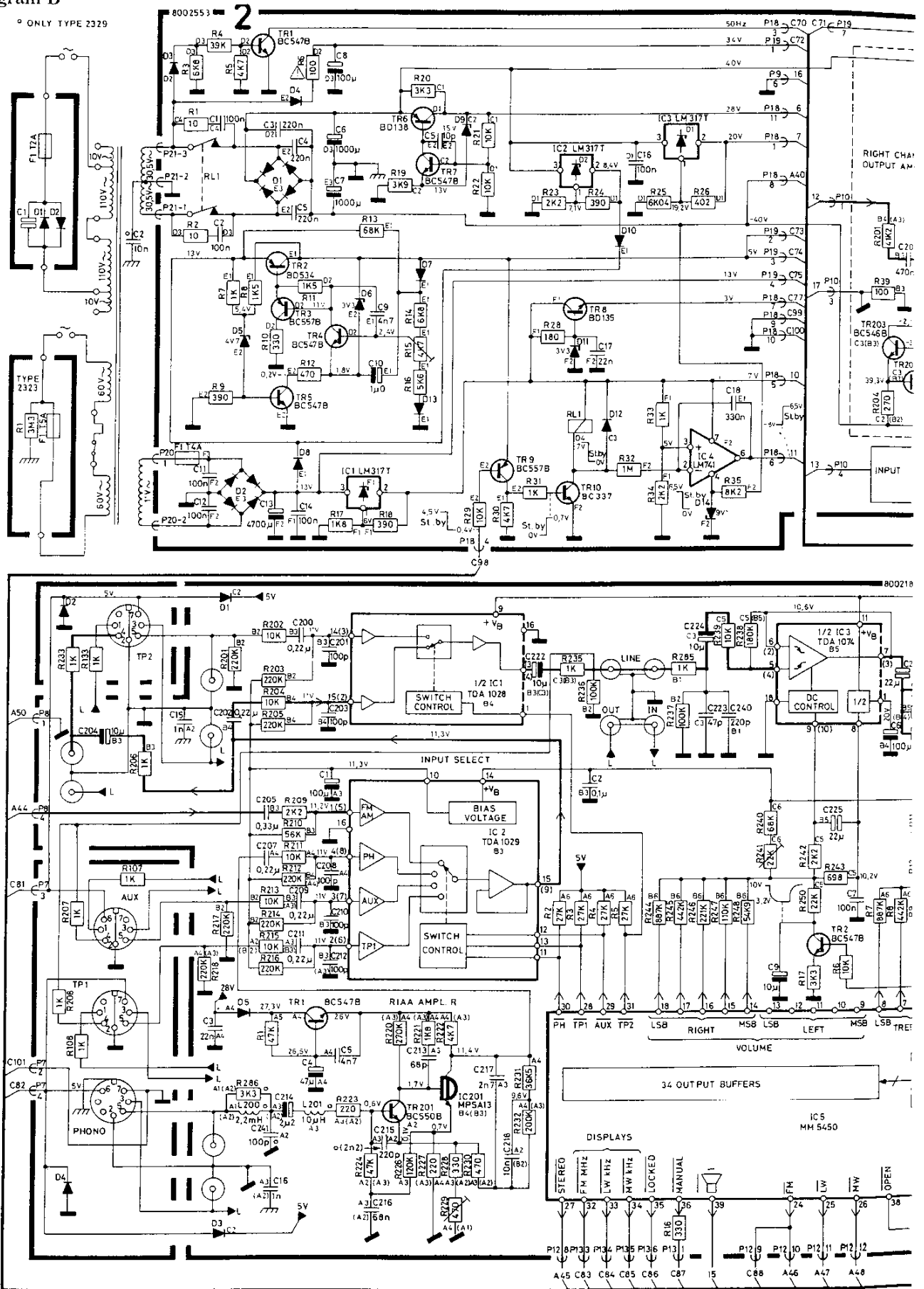

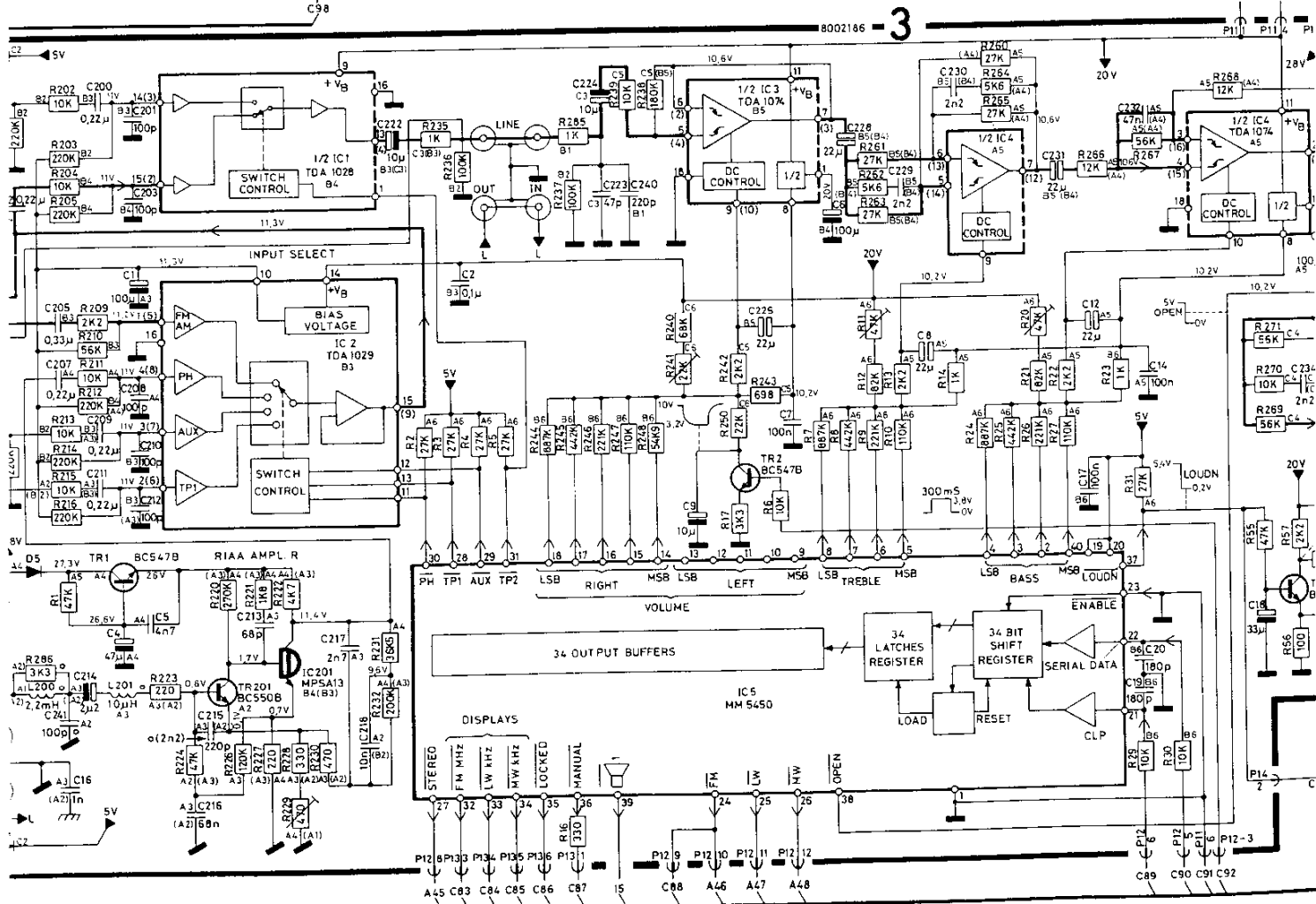
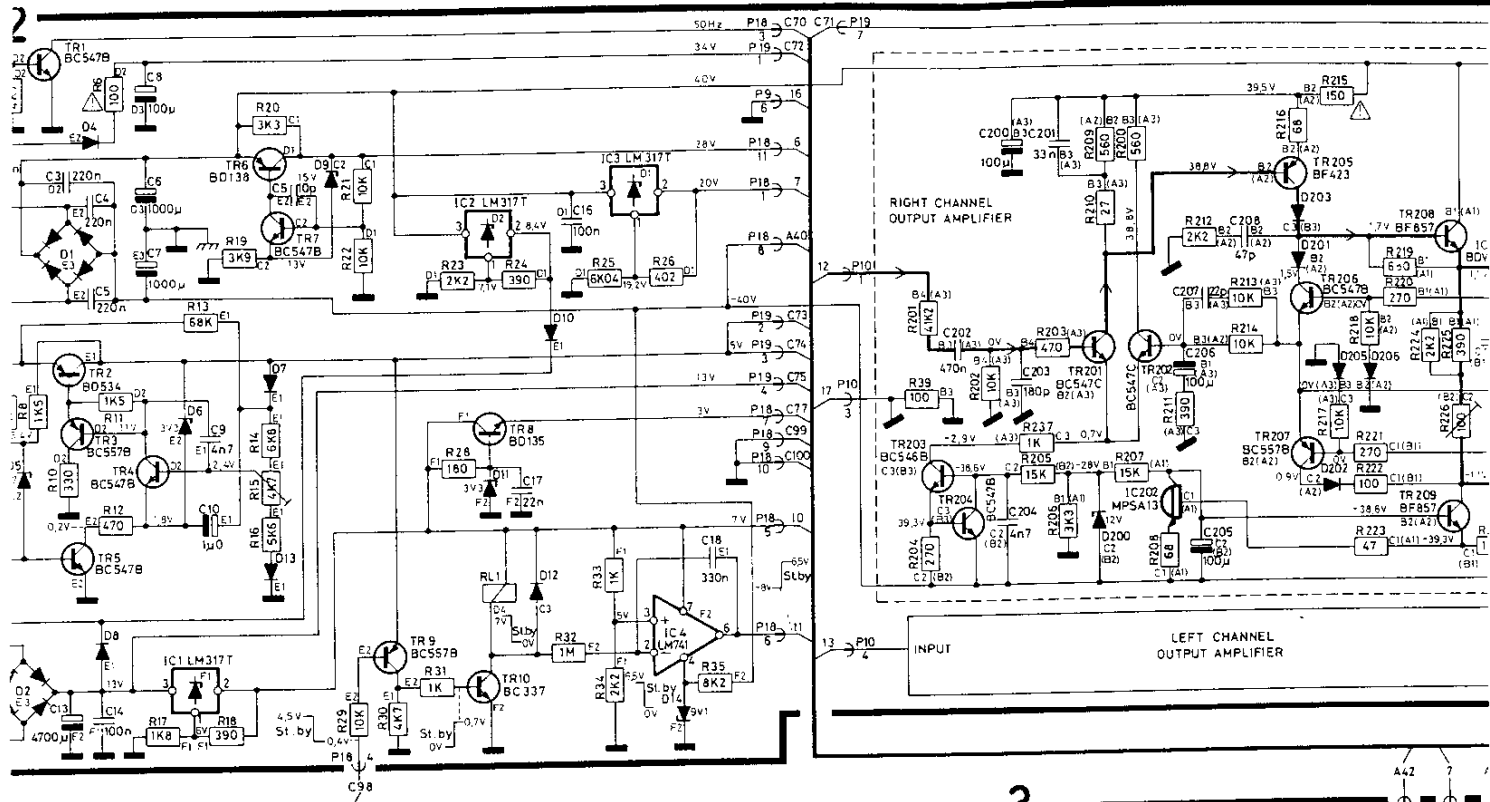



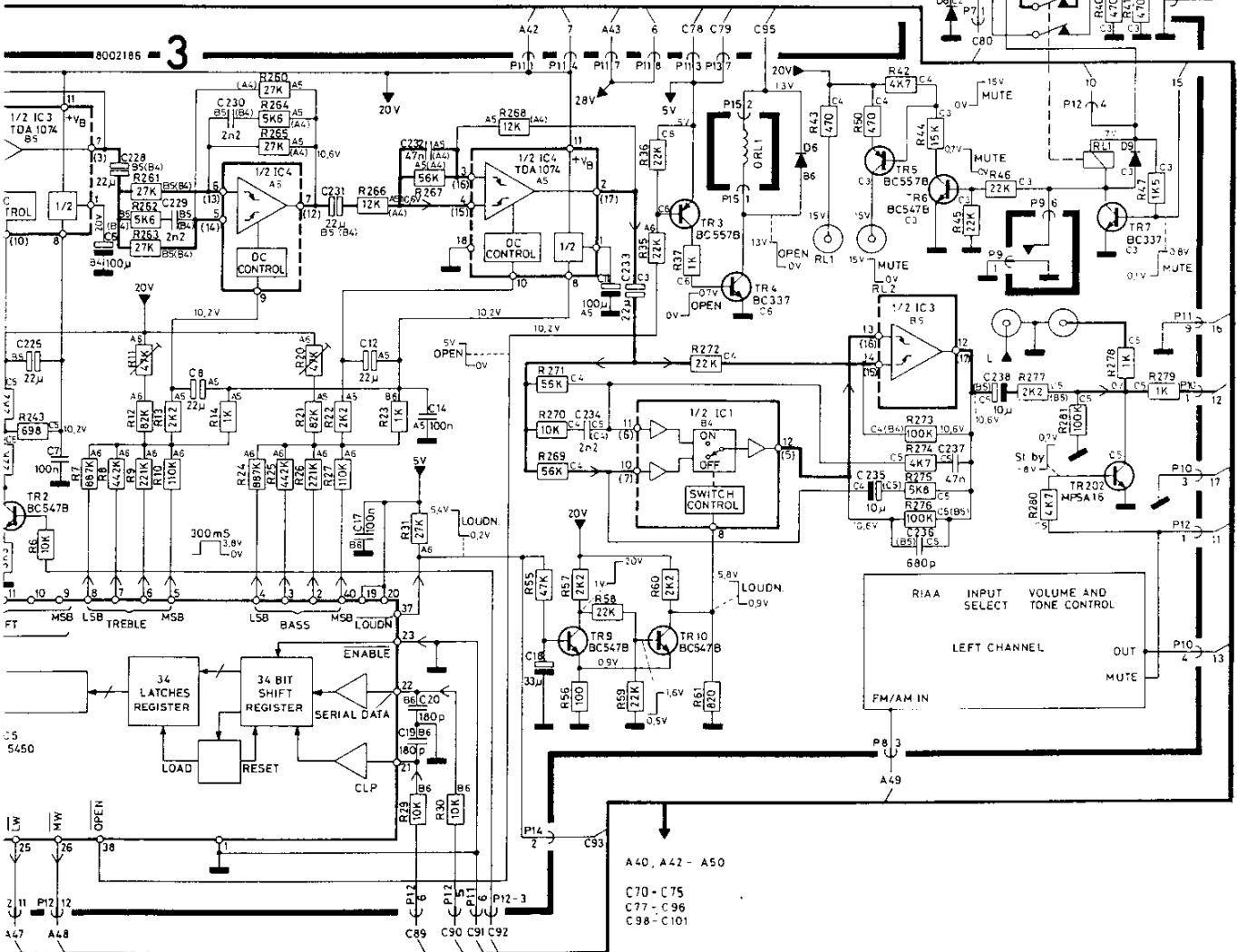
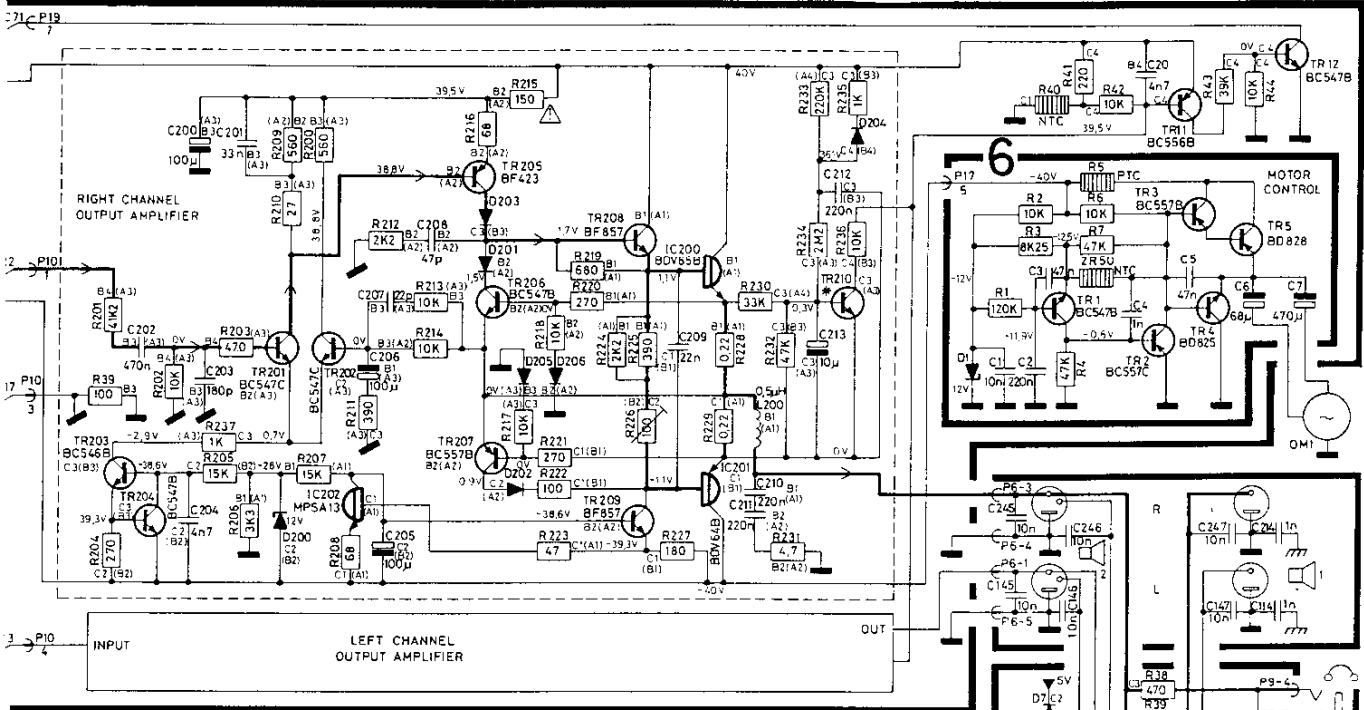

# 1-9

Diagram C

FOR SERVICE MANUALS  
CONTACT:  
**MAURITRON TECHNICAL SERVICES**  
www.mauritron.co.uk  
TEL: 01844 - 351694  
FAX: 01844 - 352554

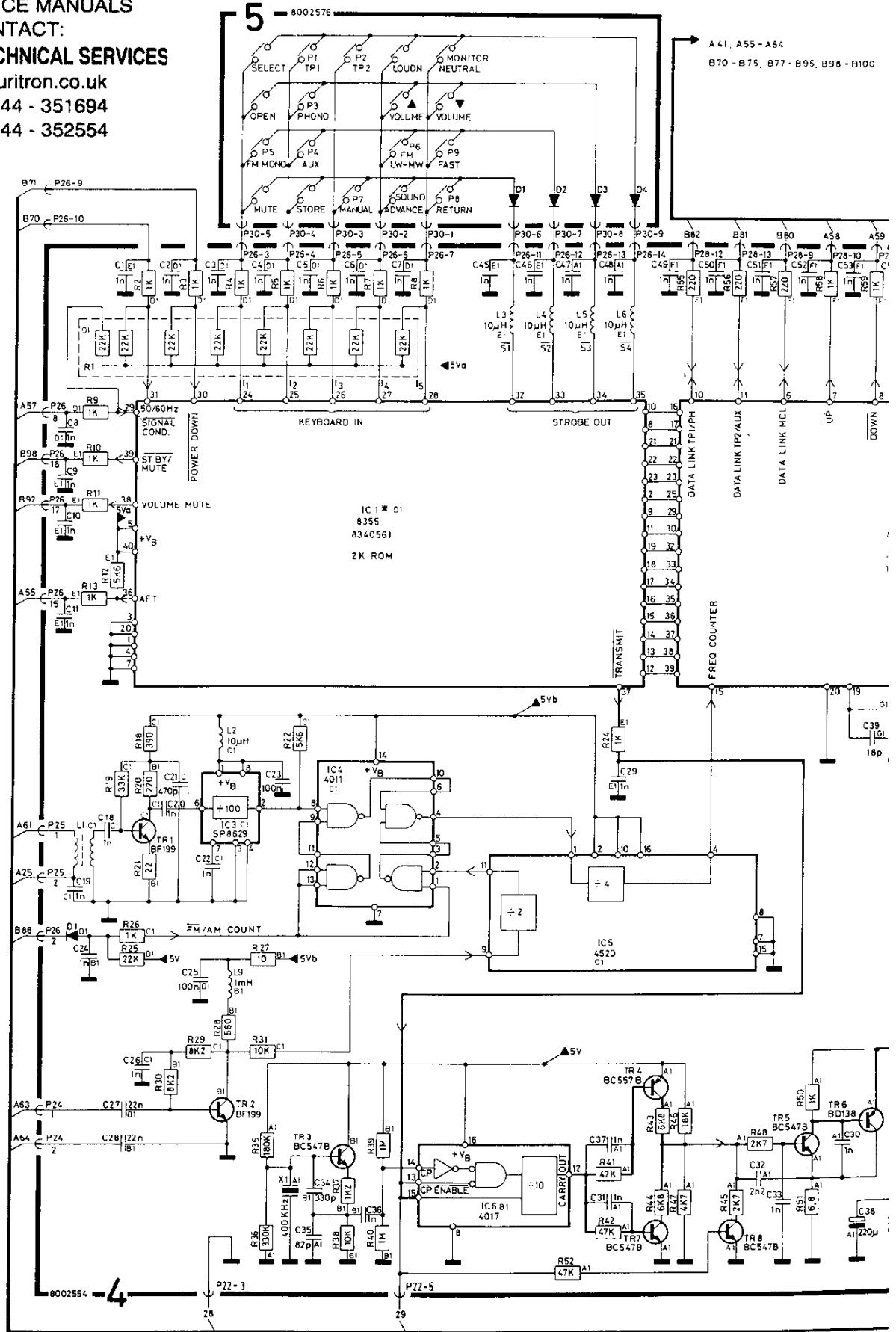

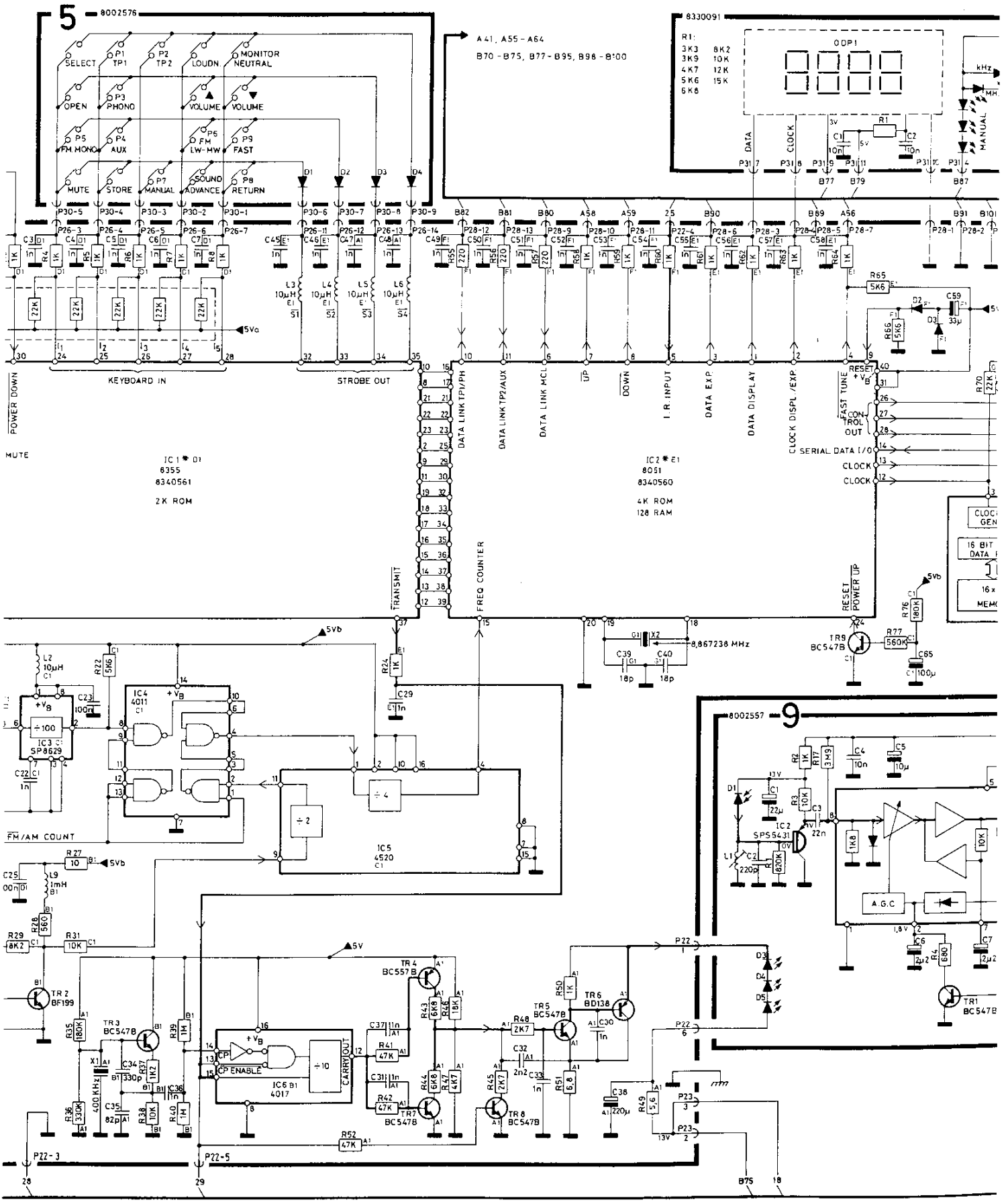

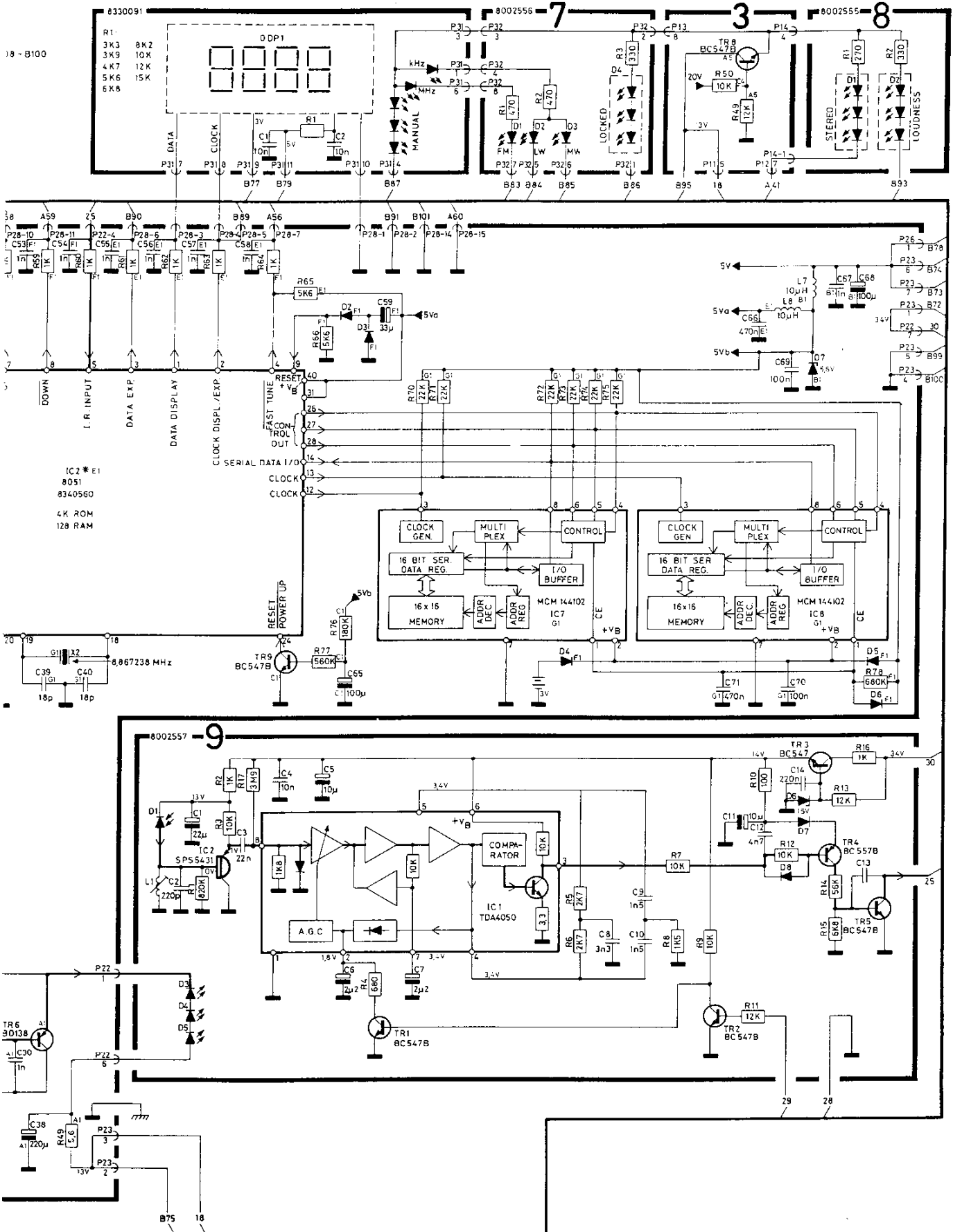

# Bang & Olufsen

Microcomputer,  
8002554, PCB4

PCB drawings are

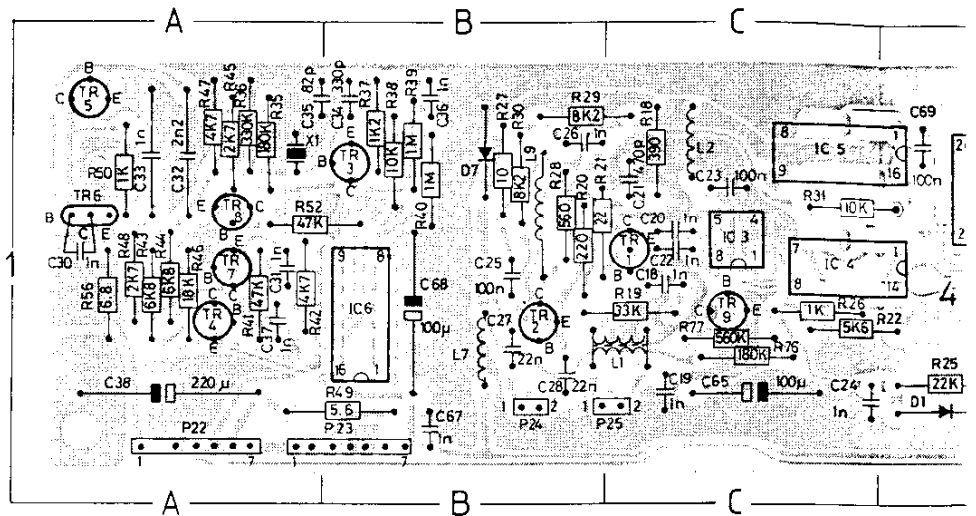

Functions Tables  
for diagram B

CONTROL VOLUME 3ICS

R. PIN	14	15	16	17	18
L. PIN	9	10	11	12	13
DISPLAY	E	D	C	B	A
60	1	1	1	1	1
58	1	1	1	1	0
56	1	1	1	0	1
54	1	1	1	0	0
52	1	1	0	1	1
50	1	1	0	1	0
48	1	1	0	0	1
46	1	1	0	0	0
44	1	0	1	1	1
42	1	0	1	1	0
40	1	0	1	0	1
38	1	0	1	0	0
36	1	0	0	1	1
34	1	0	0	1	0
32	1	0	0	0	1
30	1	0	0	0	0
28	0	1	1	1	1
26	0	1	1	1	0
24	0	1	1	0	1
22	0	1	1	0	0
20	0	1	0	1	1
18	0	1	0	1	0
16	0	1	0	0	1
14	0	1	0	0	0
12	0	0	1	1	1
10	0	0	1	1	0
08	0	0	1	0	1
06	0	0	1	0	0
04	0	0	0	1	1
02	0	0	0	1	0
00	0	0	0	0	1
00	0	0	0	0	0

FOR SERVICE MANUALS  
CONTACT:  
**MAURITRON TECHNICAL SERVICES**  
www.mauritron.co.uk  
TEL: 01844 - 351694  
FAX: 01844 - 352554

Pin config

TONE CONTROL 3ICS				
BASS PIN	40	2	3	4
TREBLE PIN	5	6	7	8
+12dB	D	C	B	A
	1	1	1	1
	1	1	1	0
	1	1	0	1
	1	1	0	0
	1	0	1	1
	1	0	1	0
	1	0	0	1
	1	0	0	0
	0	1	1	1
NEUTRAL	0	1	1	1
	0	1	1	0
	0	1	0	1
	0	1	0	0
	0	0	1	1
	0	0	1	0
-10.5dB	0	0	0	1
	0	0	0	0

Functions Tables  
for diagram C

FUNCTION TABLE FOR 4IC 7-8			
FUNCTIONS	PIN		
	4	5	6
Write	0	1	0
Read	1	1	0
Serial data in	1	0	1
Serial data out	0	1	1
Serial address in	1	0	0
No operation	0	0	1
No operation	0	0	0

- CE<sub>1</sub> 1
- CE<sub>2</sub> 2
- CLK 3
- RESET 4
- N.C. 5
- READY 6
- IO/M 7
- TOR 8
- RD 9
- TDW 10
- ALE 11
- AD<sub>0</sub> 12
- AD<sub>1</sub> 13
- AD<sub>2</sub> 14
- AD<sub>3</sub> 15
- AD<sub>4</sub> 16
- AD<sub>5</sub> 17
- AD<sub>6</sub> 18
- AD<sub>7</sub> 19
- VSS 20

PCB drawings are seen from copperfoil side

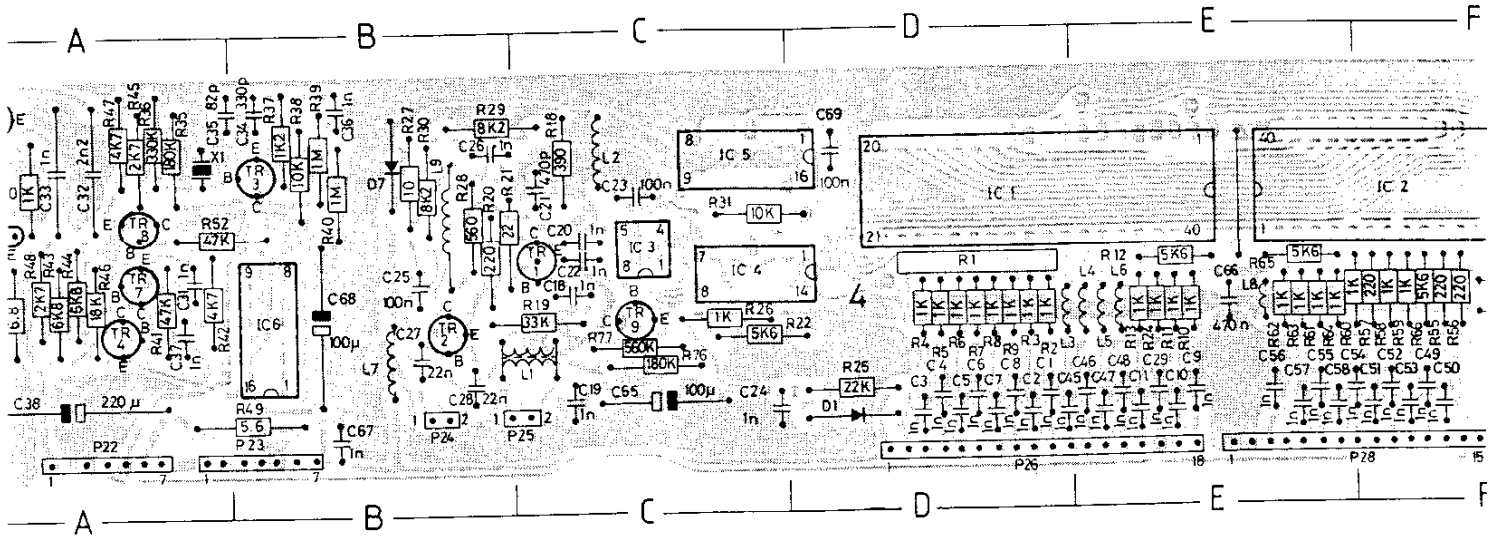

Pin configurations of microcomputers

CONTROL BITS

40	2	3	4
5	6	7	8
D	C	B	A
1	1	1	1
1	1	1	0
1	1	0	1
1	1	0	0
1	0	1	1
1	0	1	0
1	0	0	1
1	0	0	0
0	1	1	1
0	1	1	0
0	1	0	1
0	1	0	0
0	0	1	1
0	0	1	0
0	0	0	1
0	0	0	0

Functions Tables for diagram C

FUNCTION TABLE FOR 4IC 7-8

FUNCTIONS	PIN		
	4	5	6
Write	0	1	0
Read	1	1	0
Serial data in	1	0	1
Serial data out	0	1	1
Serial address in	1	0	0
No operation	0	0	1
No operation	0	0	0

4 IC 1  
8355

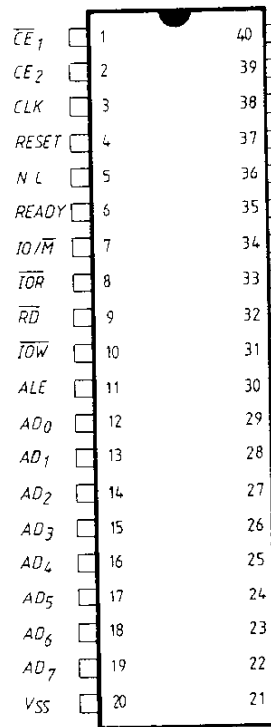

4 IC 2  
8051

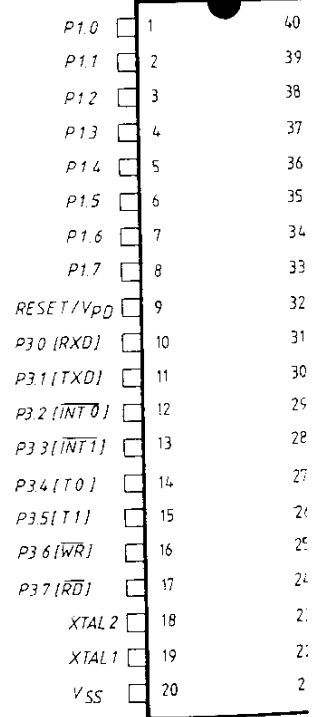

\*CB drawings are seen from copperfoil side

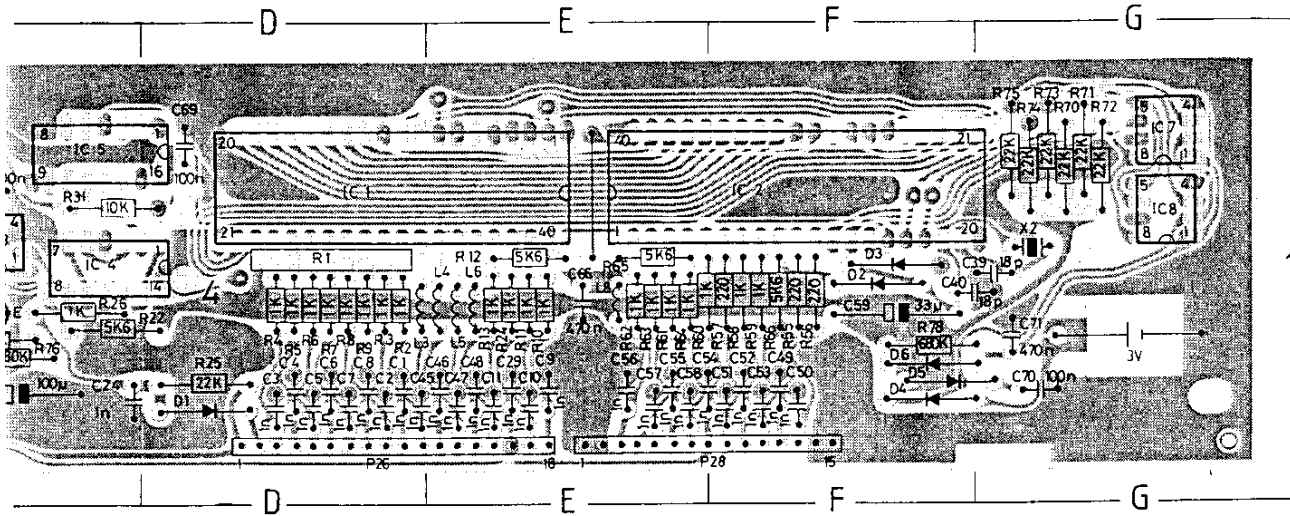

FOR SERVICE MANUALS  
CONTACT:  
**MAURITRON TECHNICAL SERVICES**  
www.mauritron.co.uk  
TEL: 01844 - 351694  
FAX: 01844 - 352554

Pin configurations of microcomputers

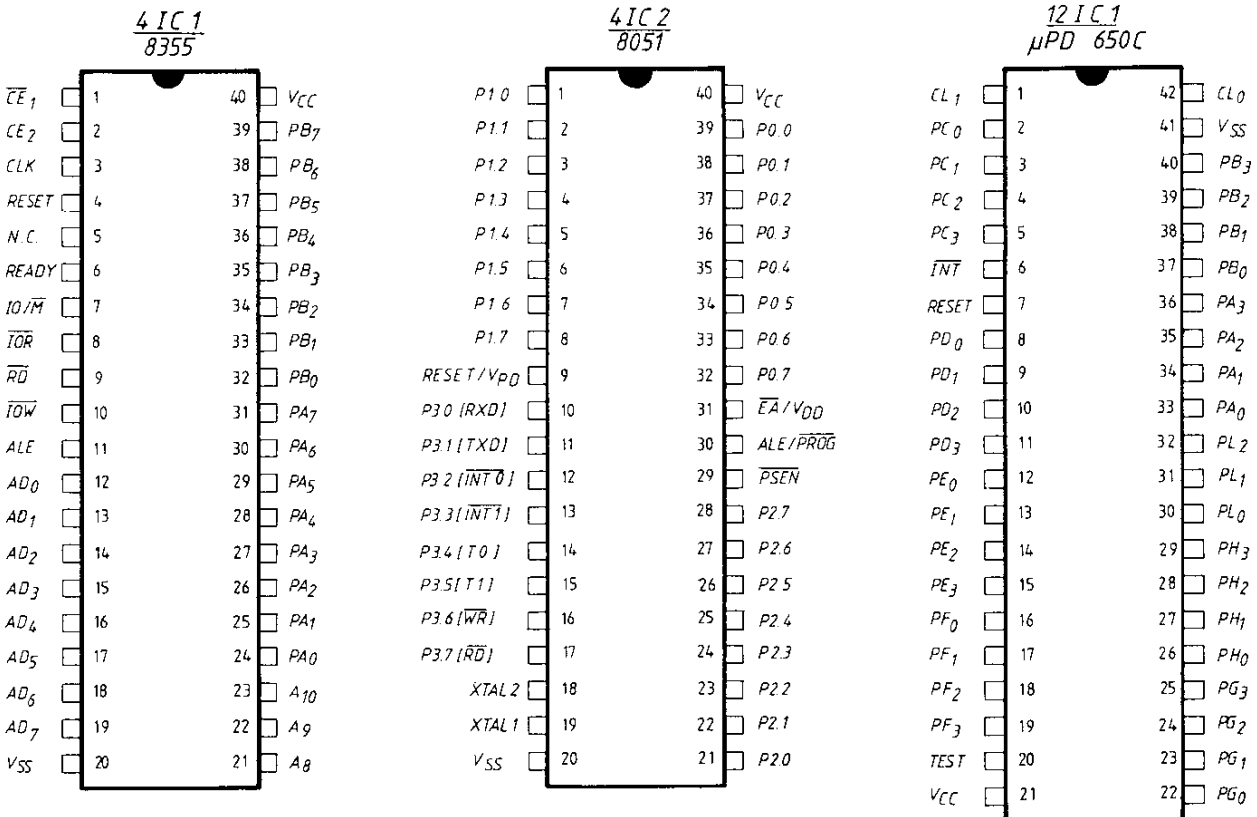

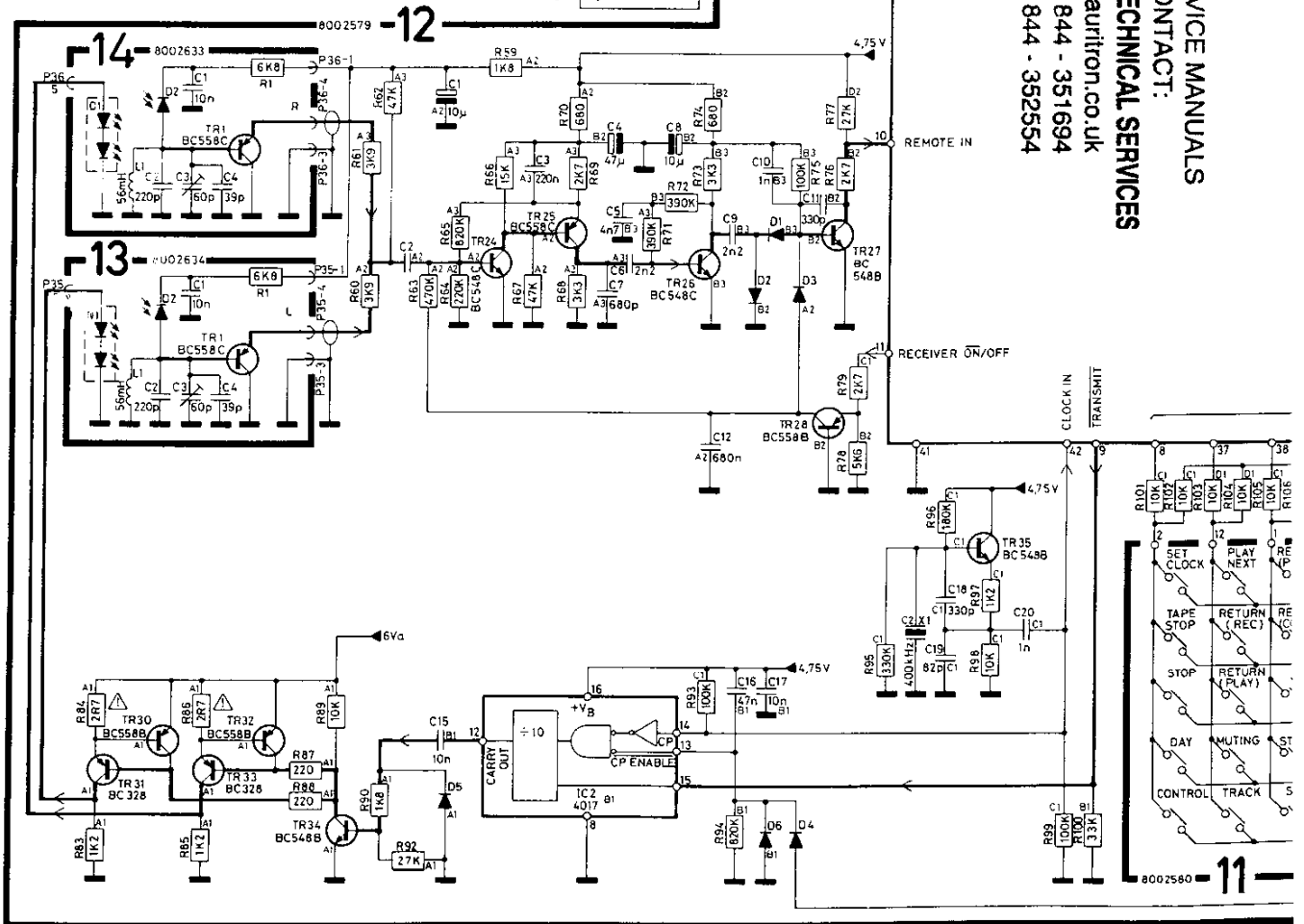
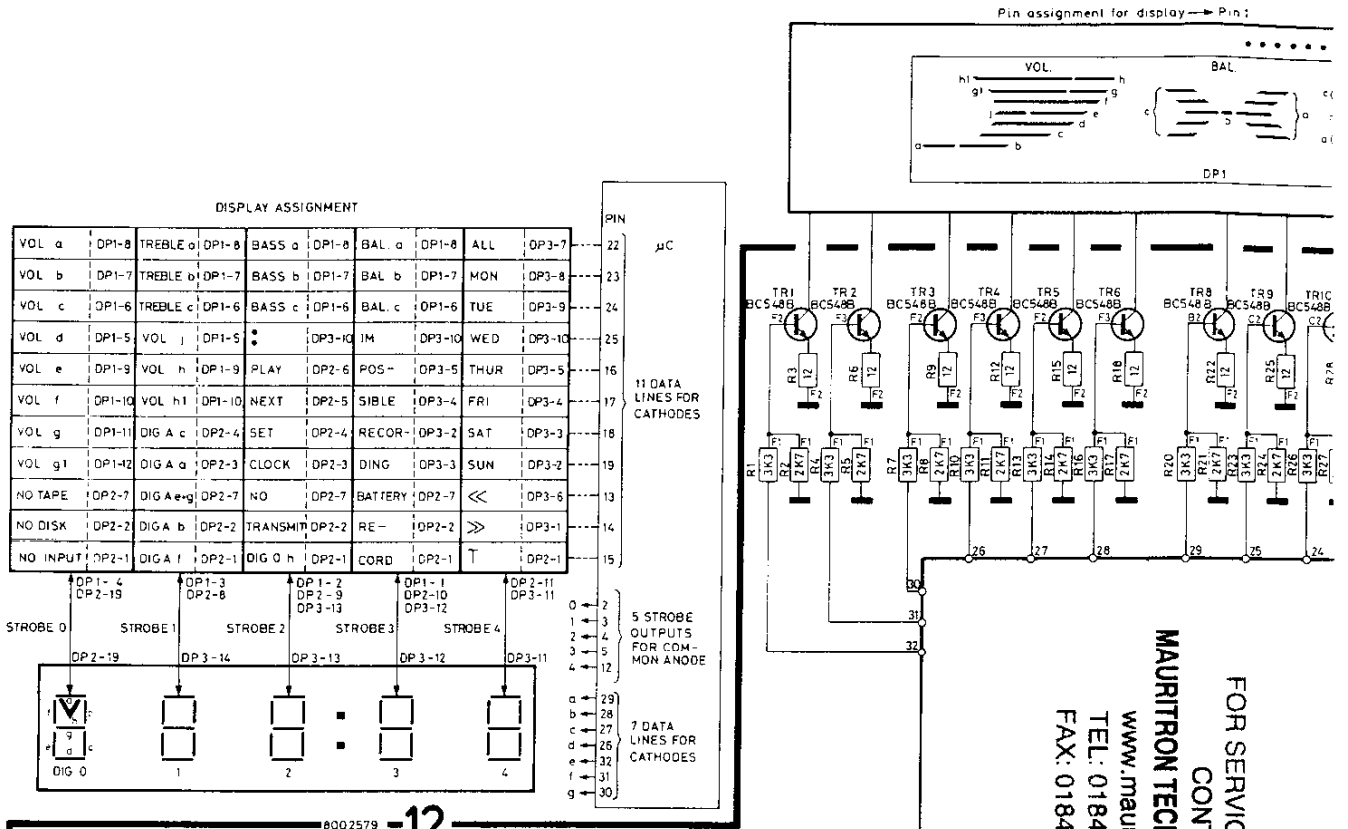



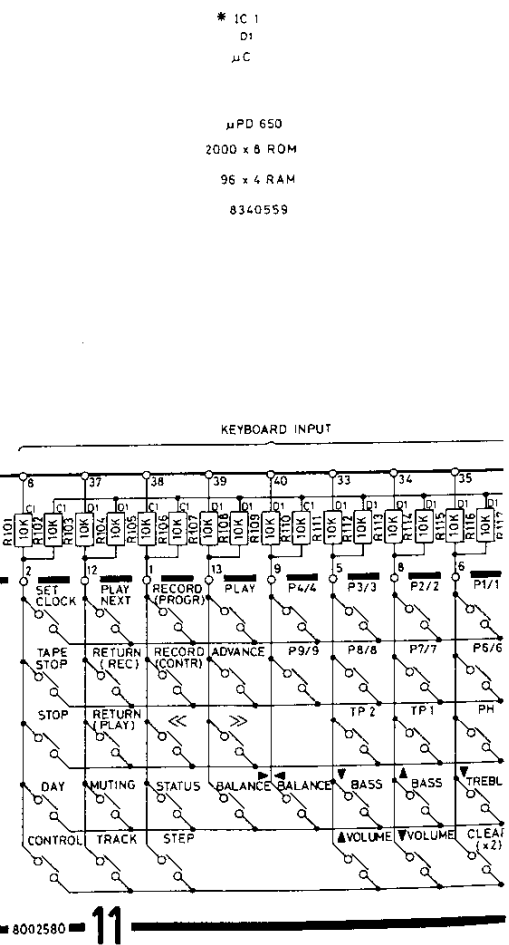
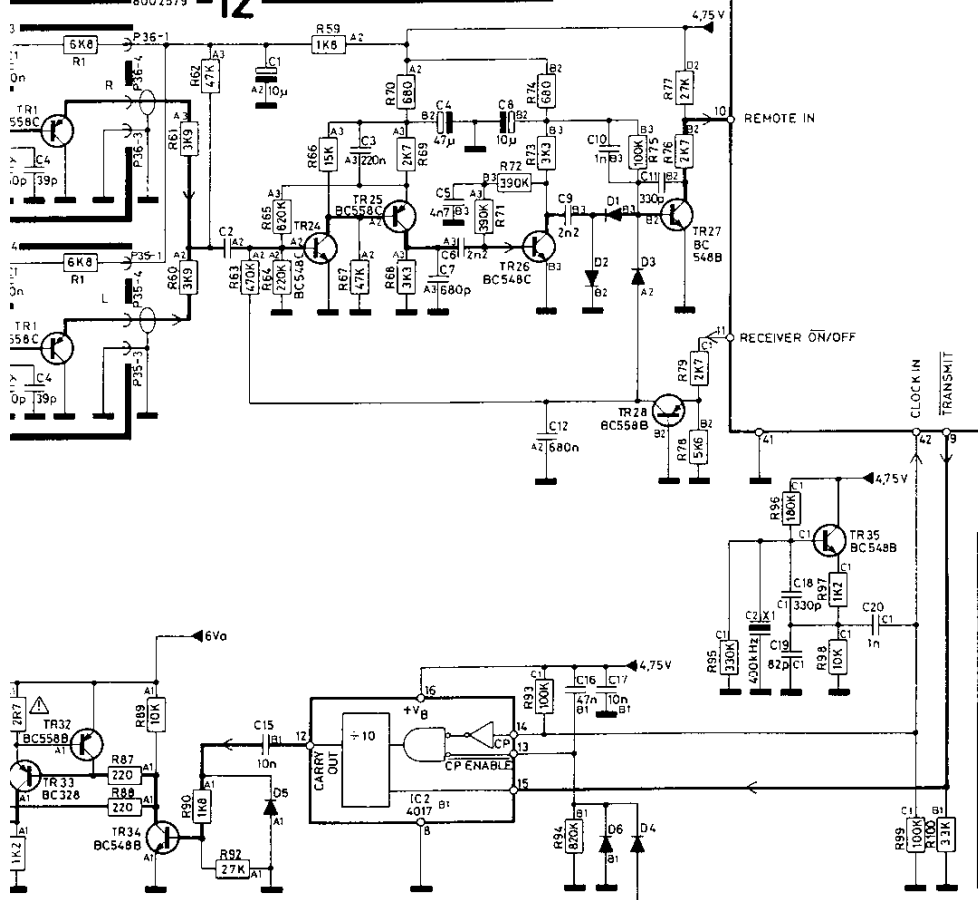
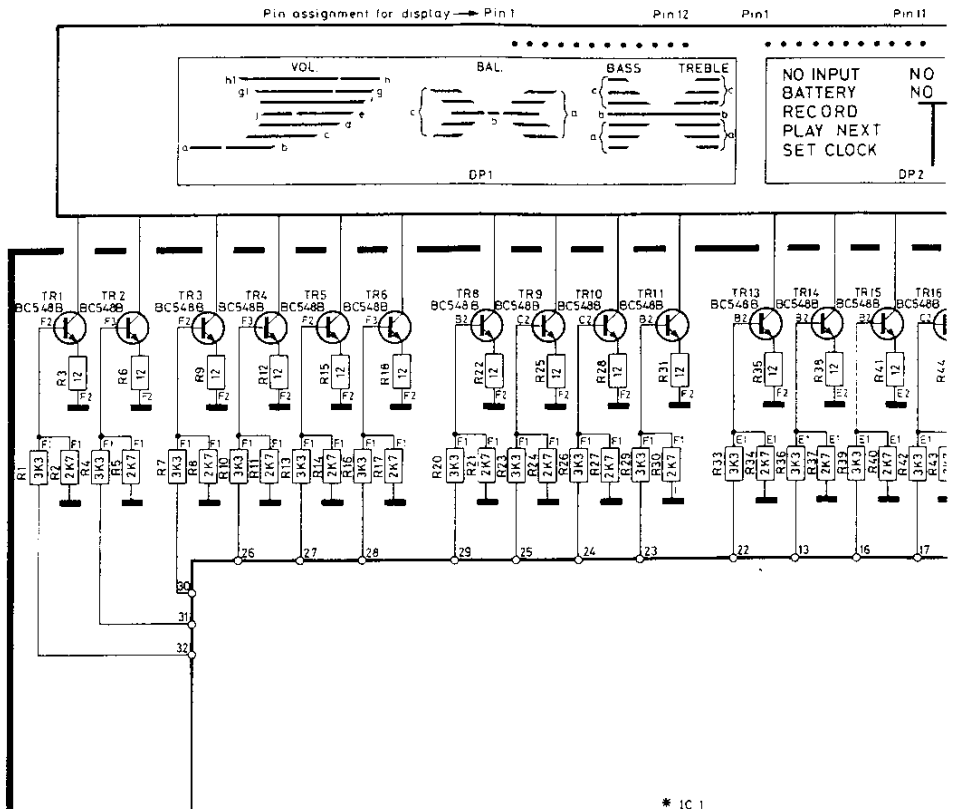
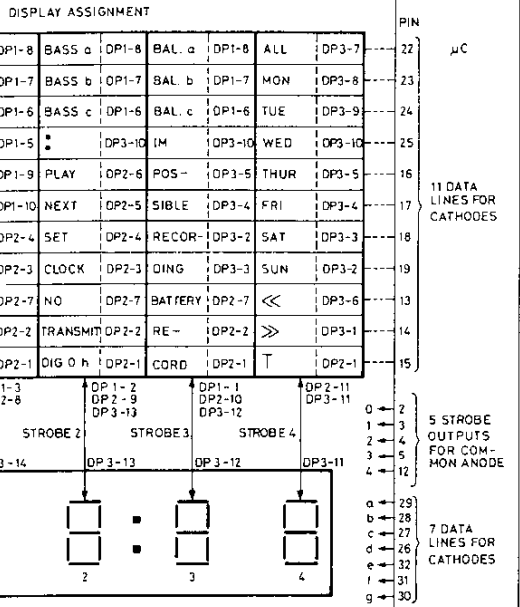

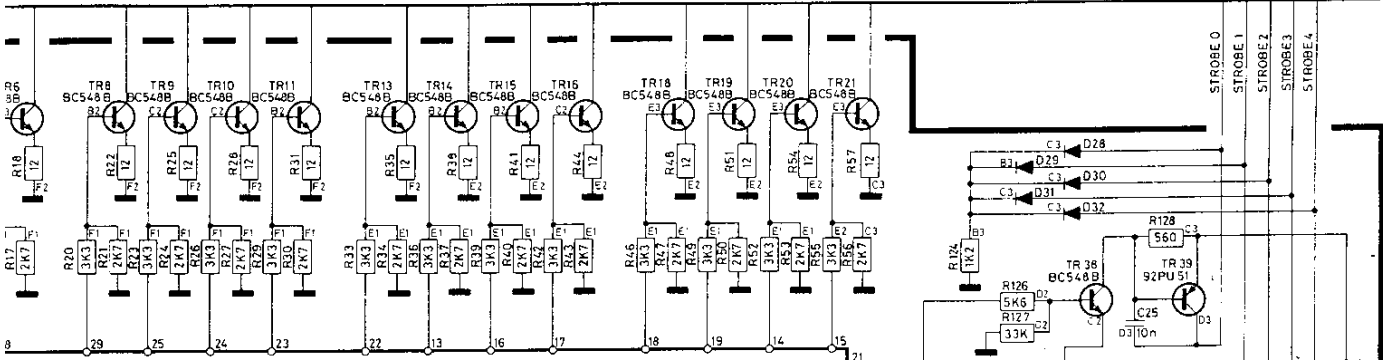
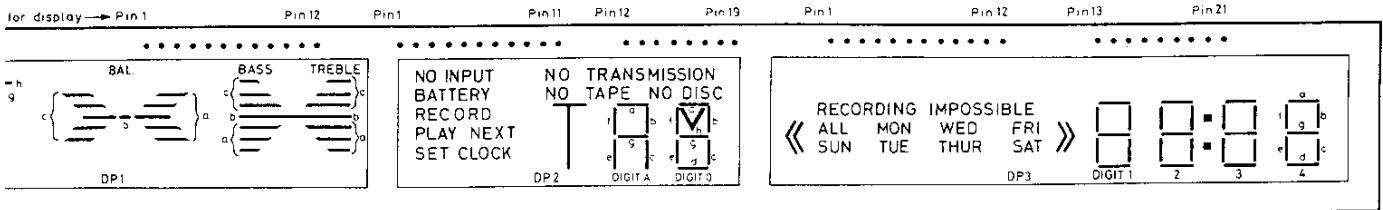

FOR SERVICE MANUALS  
 CONTACT:  
**MAURITRON TECHNICAL SERVICES**  
[www.mauritron.co.uk](http://www.mauritron.co.uk)  
 TEL: 01844 - 351694  
 FAX: 01844 - 352554

\* IC 1  
 D1  
 μC  
 μPD 650  
 2000 x 8 ROM  
 96 x 4 RAM  
 8340559

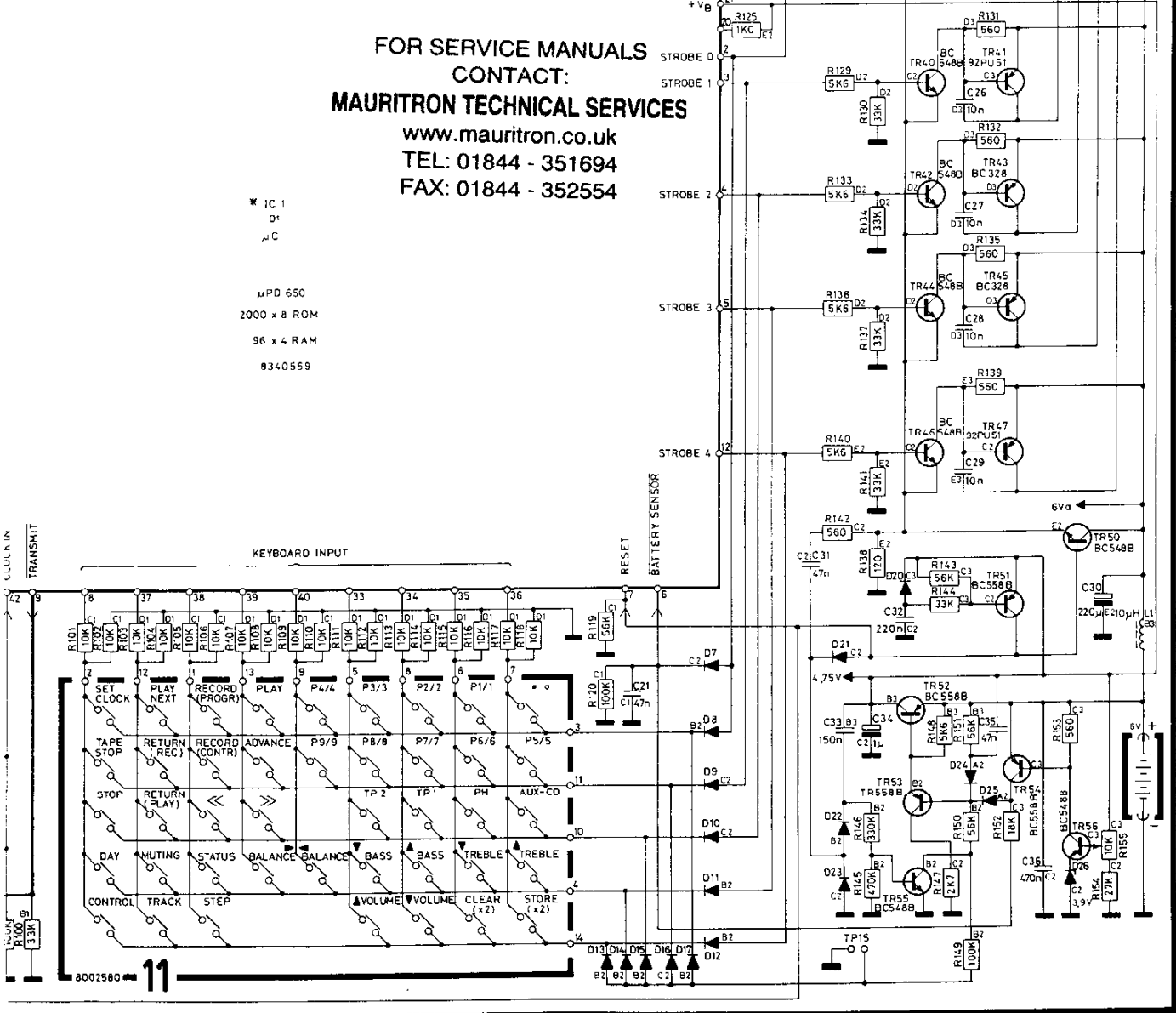

## Block Diagram Master Control Panel

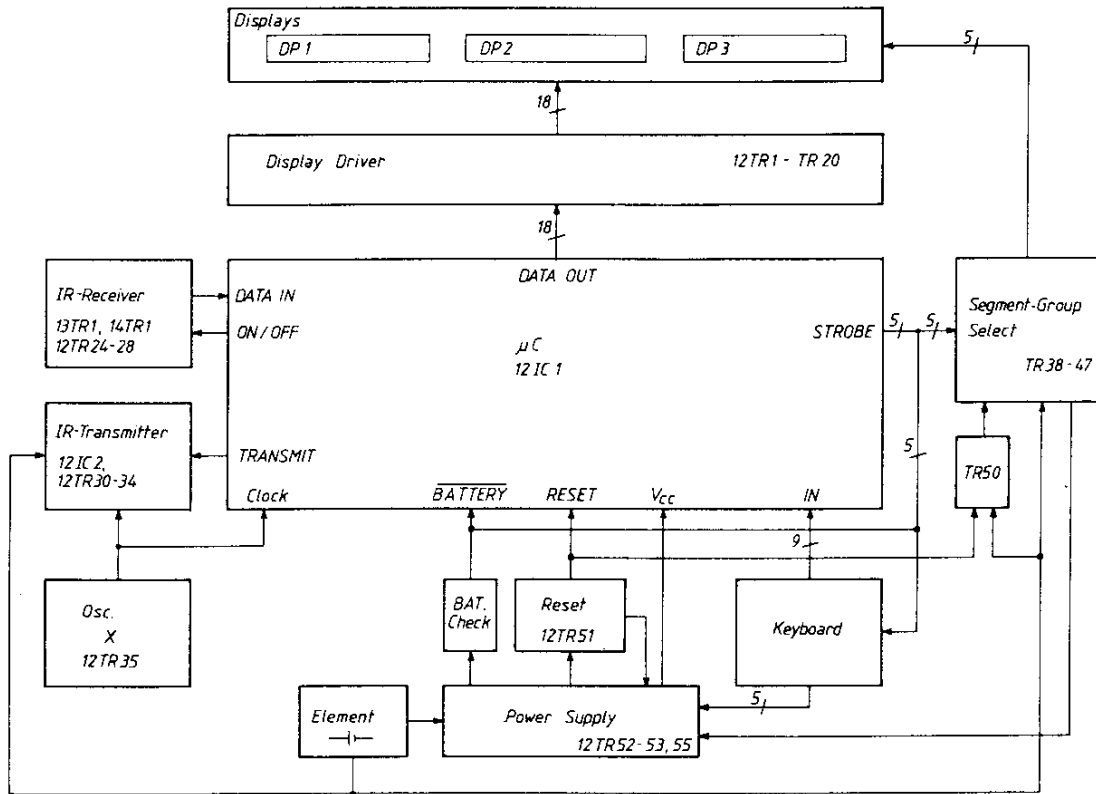

FOR SERVICE MANUALS  
CONTACT:  
**MAURITRON TECHNICAL SERVICES**  
www.mauritron.co.uk  
TEL: 01844 - 351694  
FAX: 01844 - 352554

Diagram E

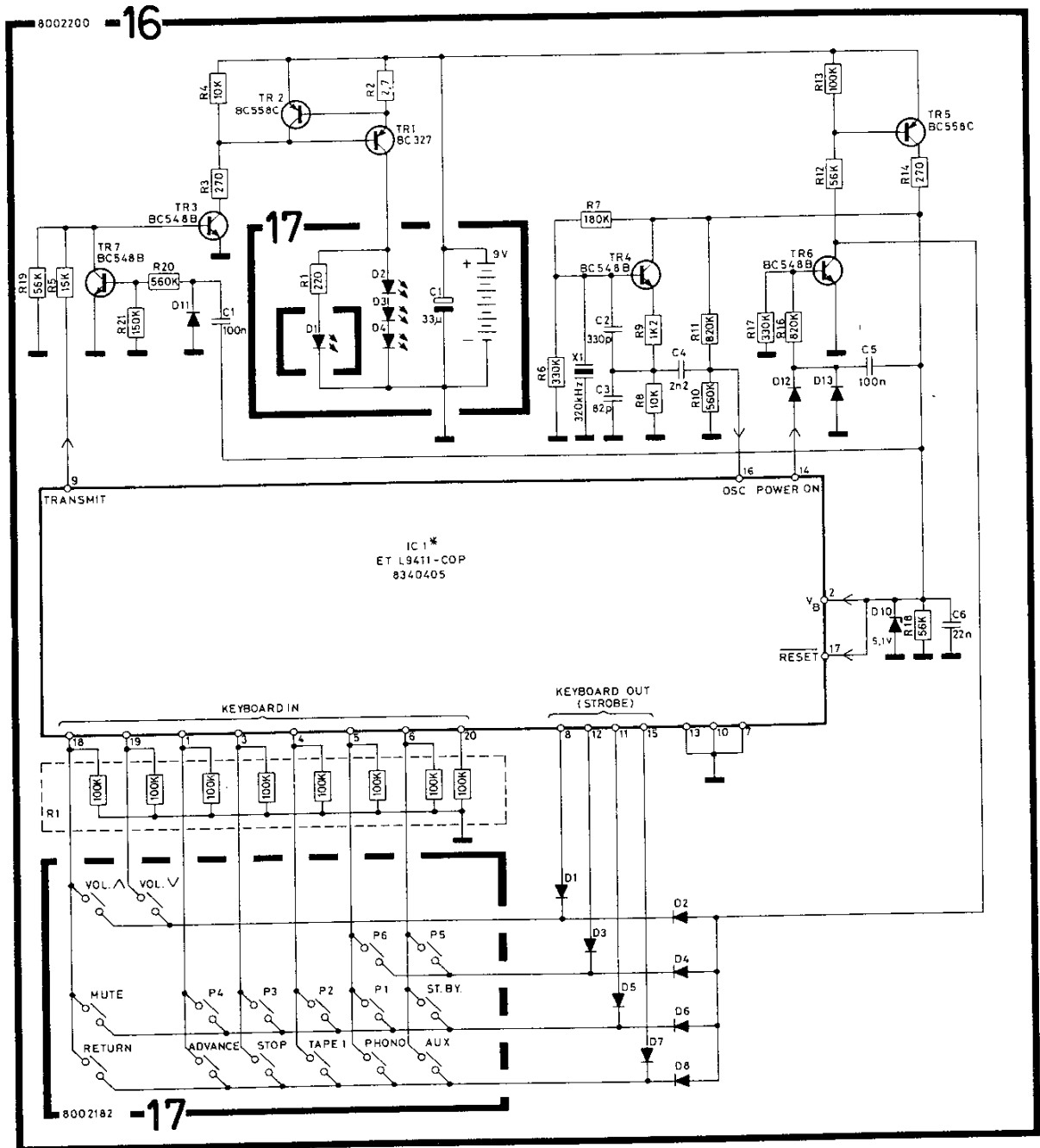

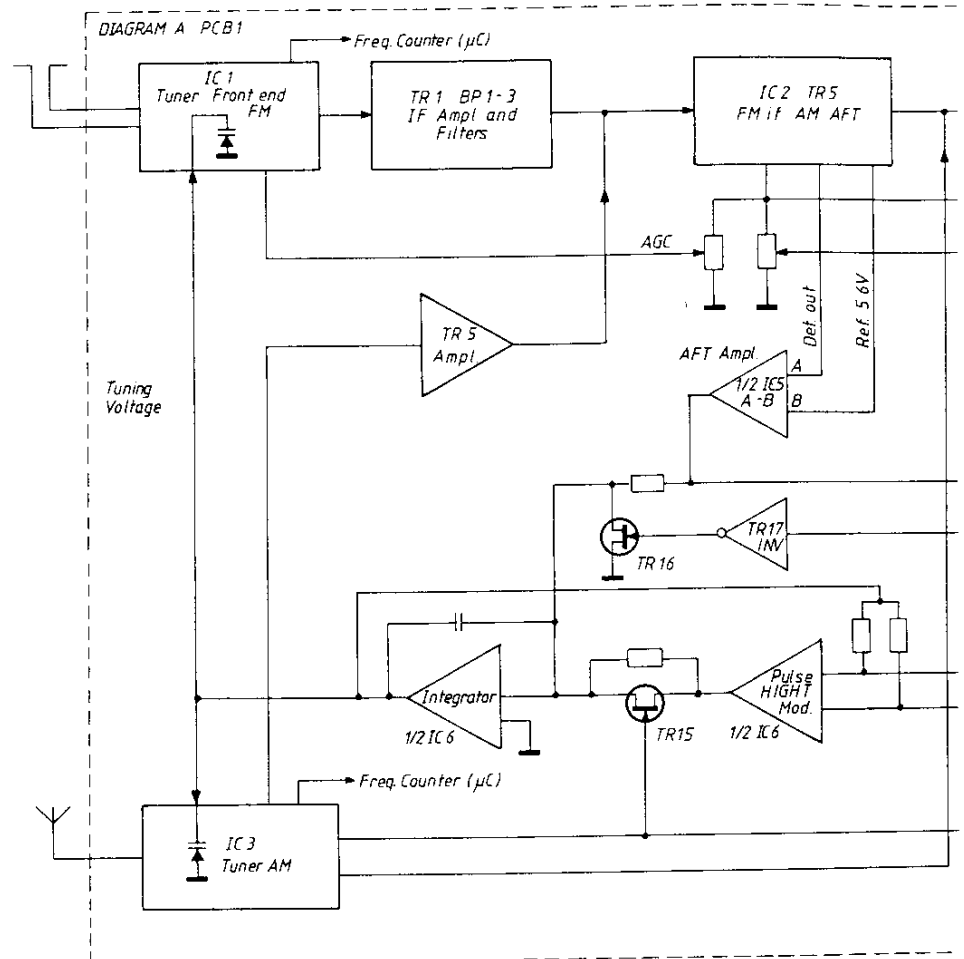

FOR SERVICE MANUALS  
CONTACT:  
**MAURITRON TECHNICAL SERVICES**  
www.mauritron.co.uk  
TEL: 01844 - 351694  
FAX: 01844 - 352554

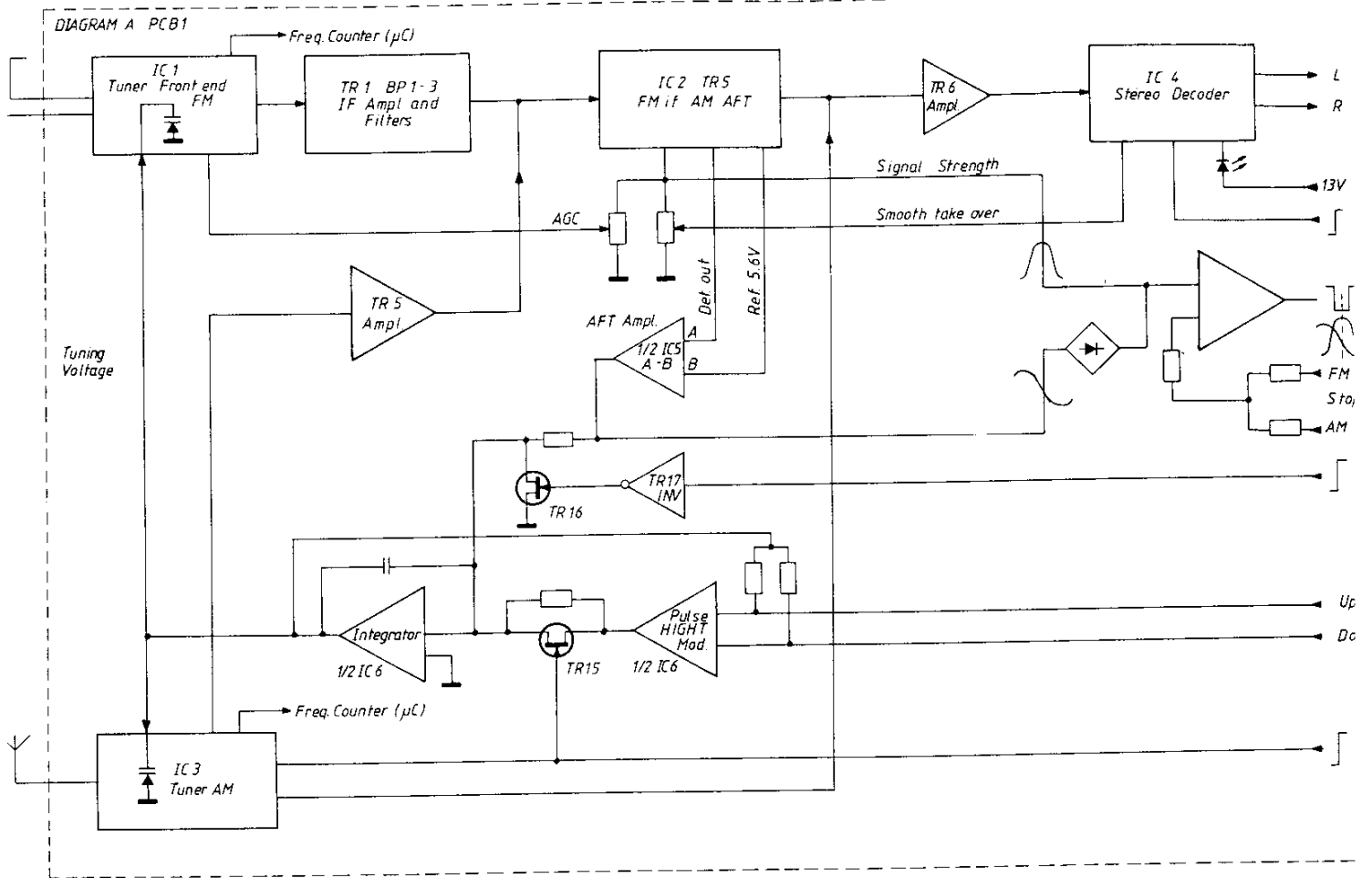

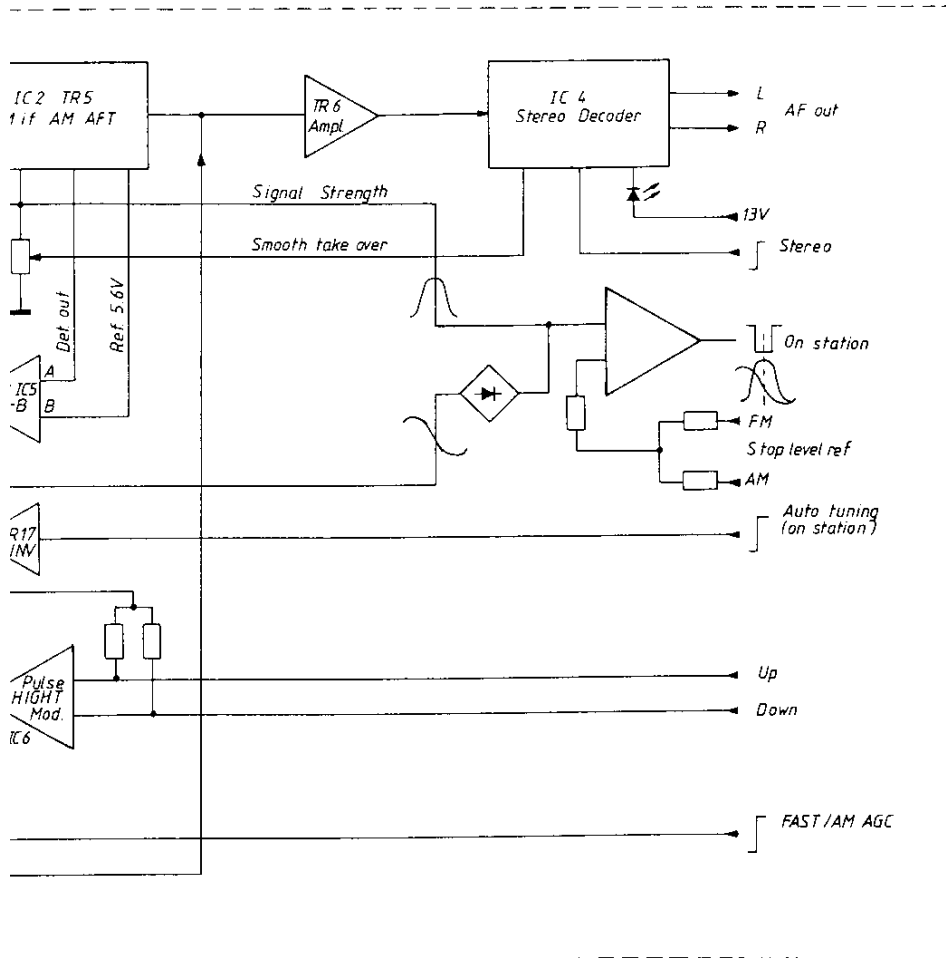

FOR SERVICE MANUALS  
 CONTACT:  
**MAURITRON TECHNICAL SERVICES**  
[www.mauritron.co.uk](http://www.mauritron.co.uk)  
 TEL: 01844 - 351694  
 FAX: 01844 - 352554

# 1-15

## Block Diagram, LF

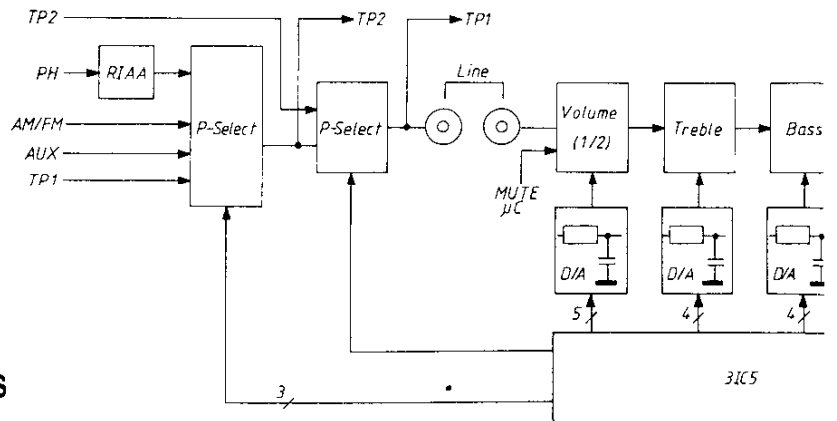

FOR SERVICE MANUALS  
CONTACT:  
**MAURITRON TECHNICAL SERVICES**  
www.mauritron.co.uk  
TEL: 01844 - 351694  
FAX: 01844 - 352554

## Block Diagram Control

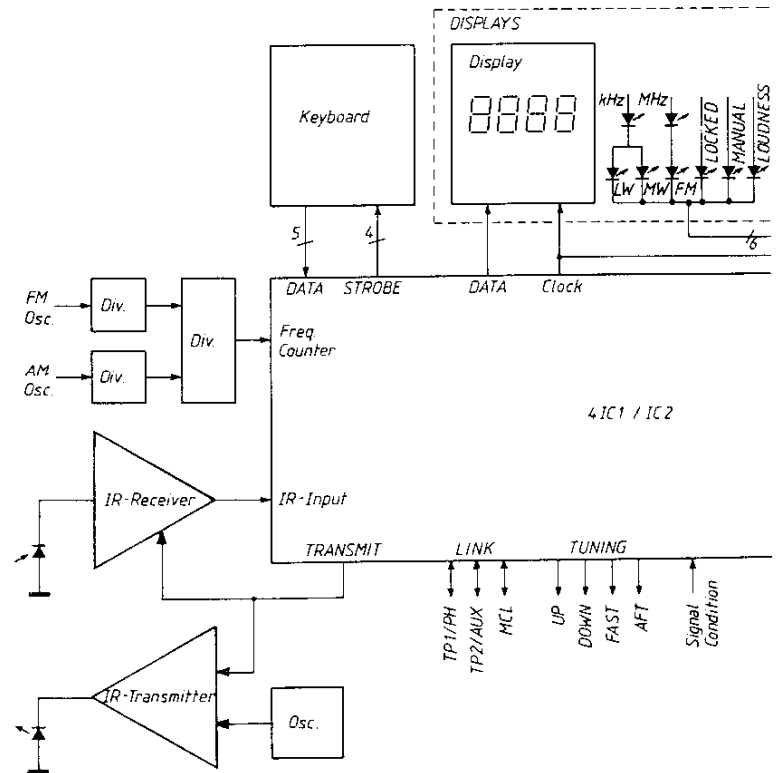



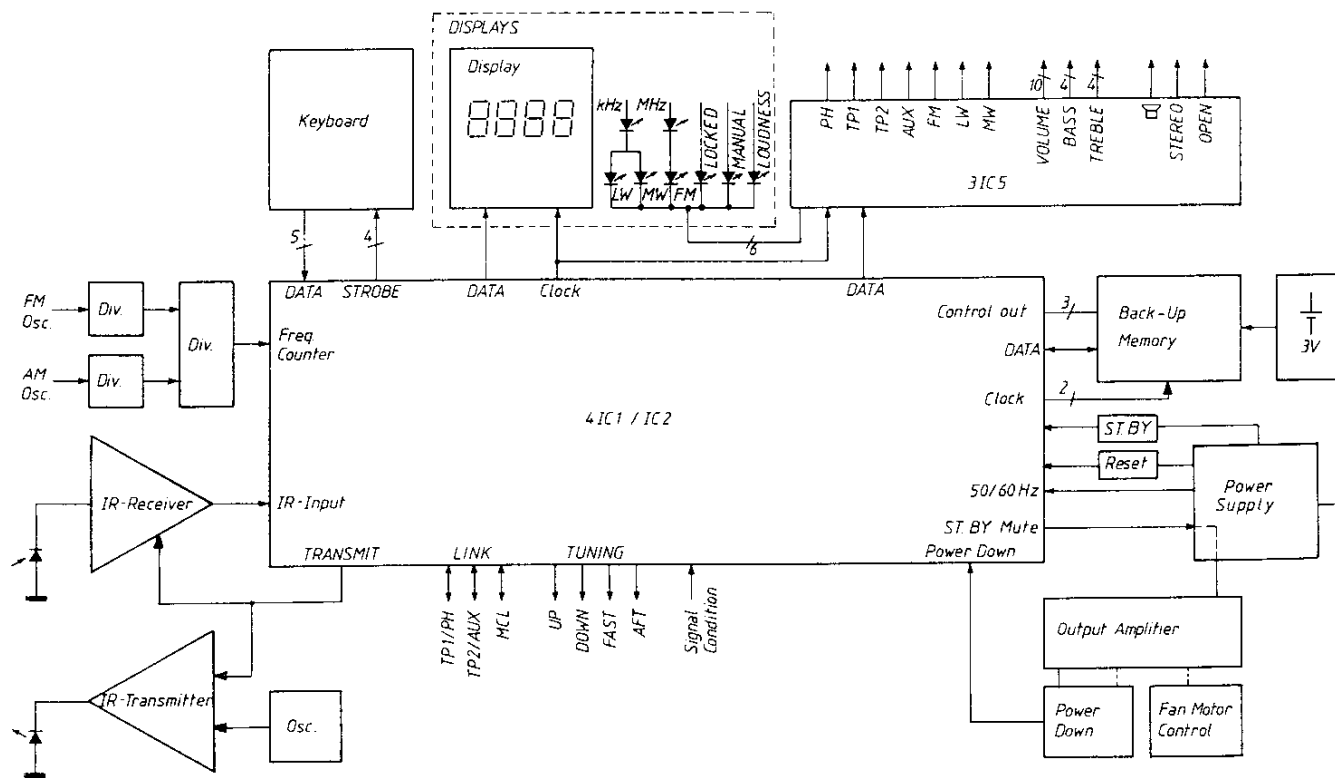
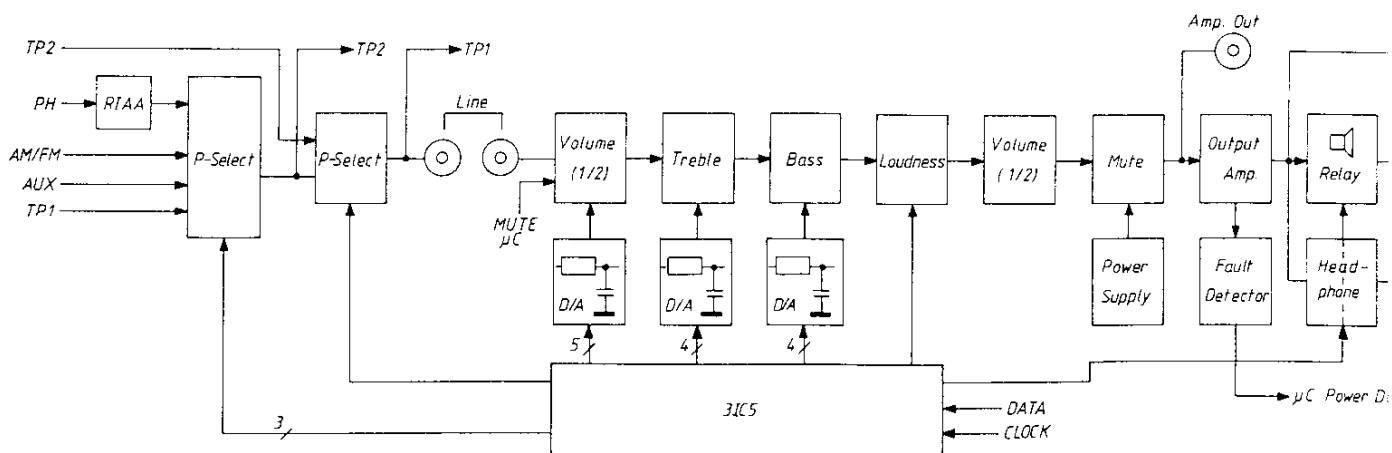

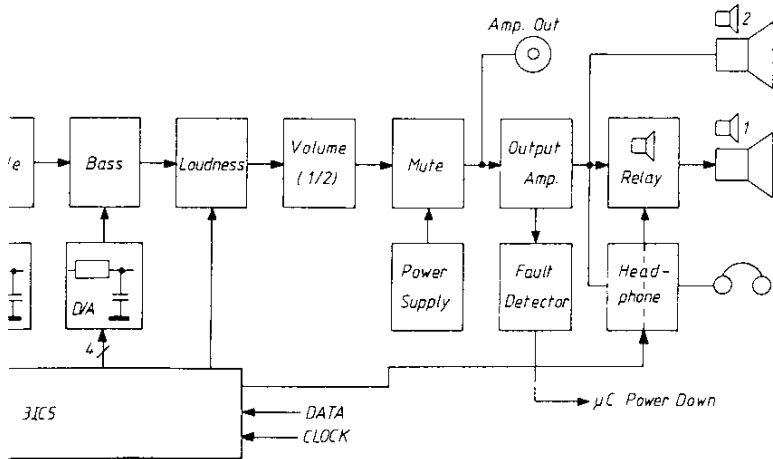



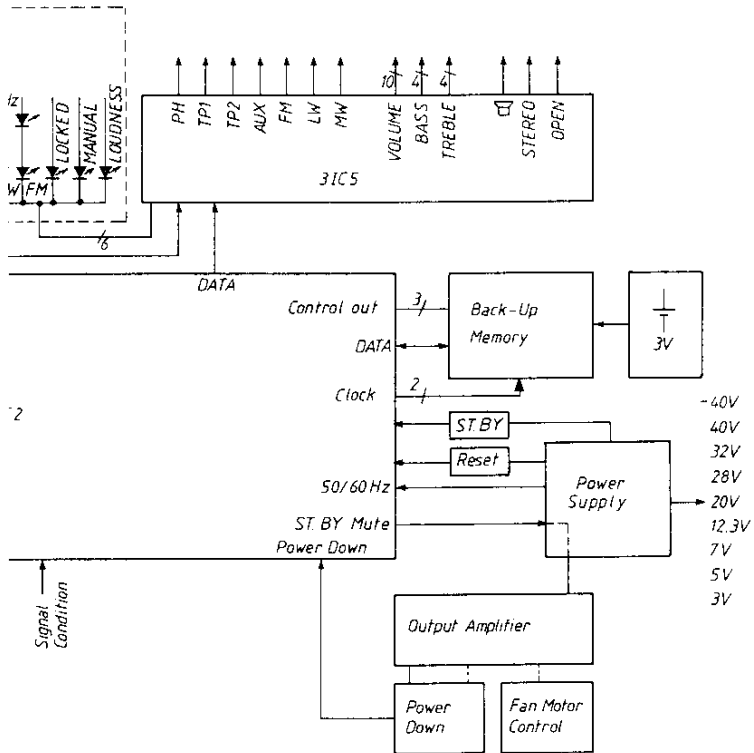







FOR SERVICE MANUALS  
CONTACT:  
**MAURITRON TECHNICAL SERVICES**  
www.mauritron.co.uk  
TEL: 01844 - 351694  
FAX: 01844 - 352554



# Bang & Olufsen

SEMI CONDUCTORS

							
<b>234</b>							
							

## List of Diodes

FOR SERVICE MANUALS  
CONTACT:  
**MAURITRON TECHNICAL SERVICES**  
www.mauritron.co.uk  
TEL: 01844 - 351694  
FAX: 01844 - 352554

ODP1	8330091								
1D1	8300308	<b>222</b>	BB 204						
1D4									
1D5	8300306	<b>226</b>	BA 479						
1D6	8300058	<b>209</b>	1N4148						
1D12		<b>217</b>	SFD 184						
		<b>215</b>	1N4148						
1D14	8300384	<b>234</b>	KV 1226						
1D15									
1D16	8300385	<b>209</b>	BA 423						
1D18									
1D19	8300058	<b>209</b>	1N4148						
1D27		<b>217</b>	SFD 184						
		<b>215</b>	1N4148						
1D28	8300053	<b>209</b>	ZPD 15V						
		<b>209</b>	BZX 79C15V						
		<b>209</b>	BZX 83C15V						
1D32	8300058	<b>209</b>	1N4148						
1D34		<b>217</b>	SFD 184						
		<b>215</b>	1N4148						
1D36	8300058	<b>209</b>	1N4148						
1D39		<b>217</b>	SFD 184						
		<b>215</b>	1N4148						
2D1	8300011		B250C5000/ 3300						
2D2	8300297		B80C3700/ 2200						
2D3	8300058	<b>209</b>	1N4148						
2D4		<b>217</b>	SFD 184						
		<b>215</b>	1B4148						
2D5	8300309	<b>209</b>	ZPD 4.7V						
		<b>209</b>	BZX 84B4V7						
		<b>209</b>	BZX 79B4V7						
2D6	8300135	<b>209</b>	ZPD 3.3V						
		<b>209</b>	BZX 79C3V3						
		<b>209</b>	BZX 83C4V3						
2D7	8300058	<b>209</b>	1N4148						
		<b>217</b>	SFD 184						
		<b>215</b>	1N4148						
2D8	8300023	<b>209</b>	1N 4002						
		<b>209</b>	1N 4003						
2D9	8300053	<b>209</b>	ZPD 15V						
		<b>209</b>	BZX 79C15V						
		<b>209</b>	BZX 83C15V						
2D10	8300023	<b>209</b>	1N 4002						
		<b>209</b>	1N 4003						
2D11	8300135	<b>209</b>	ZPD 33V						
		<b>209</b>	BZX 79C3V3						
		<b>209</b>	BZX 83C3V3						
2D12	8300058	<b>209</b>	1N4148						
2D13		<b>217</b>	SFD 184						
		<b>215</b>	1N4148						
2D14	8300028	<b>209</b>	ZPD 9.1V						
		<b>209</b>	BZX 79C9V1						
		<b>209</b>	BZX 83C9V1						
2D200	8300029	<b>209</b>	ZPD 12V						
		<b>209</b>	BZX 79C12V						
		<b>209</b>	BZX 83C12V						
2D201	8300058	<b>209</b>	1N4148						
2D206		<b>217</b>	SFD 184						
		<b>215</b>	1N4148						
3D1	8300058	<b>209</b>	1N4148						
3D5		<b>217</b>	SFD 184						
		<b>215</b>	1N4148						
3D6	8300023	<b>209</b>	1N4002						
		<b>209</b>	1N4003						
3D7	8300058	<b>209</b>	1N4148						
3D9		<b>217</b>	SFD 184						
		<b>215</b>	1N4148						

4D1	8300058	209	1N4148	9D7	8300058	209	1N4148
		217	SFD 184	9D8		217	SFD 184
		215	1N4148			215	1N4148
4D2	8300142	209	AA 143	12D1-	8300058	209	1N4148
4D3		209	QA 47	12D25		217	SFD 184
						215	1N4148
4D4	8300058	209	1N4148	12D26	8300404	209	83C 3.9V
4D5		217	SFD 184	12D28	8300058	209	1N4148
		215	1N4148	12D32		217	SFD 184
4D6	8300142	209	OA47			215	1N4148
		209	OA 47	12DP1	8330100		NSB 4060
4D7	8300128	209	ZPD 5.6V	12DP2	8330101		NSB 4069
		209	BZX 79C5V6	12DP3	8330102		NSB 4070
		209	BZX 83C5V6	13D1	8330094	235	CQX 47
5D1	8300142	209	AA 143	13D2	8330004	219	SFH 205
5D4		209	OA 47	14D1	8330094	235	CQX 47
6D1	8300029	209	ZPD 12V	14D2	8330004	219	SFH 205
		209	BZX 79C12V	16D1-	8300058	209	1N4148
		209	BZX 83C12V	16D9		217	SFD 184
7D1	8330081	232	SLF-102B			215	1N4148
7D3							
7D4	8330083	233	SLF-203B				
8D1	8330082	233	SLD-103B				
8D2	8330083	233	SLF-203B				
9D1	8330004	219	SHF 205				
9D3	8330097	203	CQW 14				
9D5							
9D6	8300053	209	ZPD 15V				
		209	BZX 79C15V				
		209	BZX 83C15V				

FOR SERVICE MANUALS

CONTACT:

**MAURITRON TECHNICAL SERVICES**

[www.mauritron.co.uk](http://www.mauritron.co.uk)

TEL: 01844 - 351694

FAX: 01844 - 352554

# 2-2

## List of Transistors

<b>41</b>	<b>42</b>	<b>43</b>	<b>44</b>	<b>49</b>			

1TR1	8320377	<b>20</b>	BC 547C	1TR36	8320097	<b>20</b>	BC 547B
1TR2	8320281	<b>42</b>	BF 199	1TR37	8320242	<b>20</b>	BC 556B
1TR3	8320097	<b>20</b>	BC 547B	1TR38	8320391	<b>17</b>	BC 638
1TR5	8320377	<b>20</b>	BC 547C	1TR39	8320097	<b>20</b>	BC 547B
1TR6	8320097	<b>20</b>	BC 547B	1TR40			
1TR7	8320152	<b>20</b>	BC 557B	2TR1	8320097	<b>20</b>	BC 547B
1TR8				2TR2	8320369	<b>31</b>	BD 534
1TR9	8320097	<b>20</b>	BC 547B			<b>33</b>	BD 540A
1TR10				2TR3	8320152	<b>20</b>	BC 557B
1TR11	8320152	<b>20</b>	BC 557B	2TR4	8320097	<b>20</b>	BC 547B
1TR12				2TR5			
1TR14	8320097	<b>20</b>	BC 547B	2TR6	8320241	<b>32</b>	BP 138
1TR15	8320536	<b>24</b>	MPF 4393-18	2TR7	8320097	<b>20</b>	BC 547B
1TR16	8320396	<b>24</b>	MPF 4392	2TR8*	8320239	<b>32</b>	BD 135
1TR17	8320152	<b>20</b>	BC 557B	2TR9	8320152	<b>20</b>	BC 557B
1TR19				2TR10	8320295	<b>20</b>	BC 337-25/18
1TR20	8320329	<b>20</b>	BC <del>338-25</del>	2TR11	8320242	<b>20</b>	BC 556B
1TR21	8320396	<b>24</b>	MPF 4392	2TR12	8320097	<b>20</b>	BC 547B
1TR22	8320097	<b>20</b>	BC 547B	2TR201	8320377	<b>20</b>	BC 547C
1TR23	8320535	<b>22</b>	BC 256C	2TR202			
1TR26	8320097	<b>20</b>	BC 547C	2TR203	8320237	<b>20</b>	BC 546B
1TR31				2TR204	8320097	<b>20</b>	BC 547B
1TR32	8320152	<b>20</b>	BC 557B	2TR205	8320454	<b>17</b>	BF 423
1TR33				2TR206	8320097	<b>20</b>	BC 546B
1TR34	8320368	<b>31</b>	BD 533	2TR207	8320152	<b>20</b>	BC 557B
			<b>33</b>				
1TR35	8320152	<b>20</b>	BC 557B				

2TR208	8320460	44	BF 857
2TR209			
2TR210	8320546	49	BF 422
3TR1	8320097	20	BC 547B
3TR2			
3TR3	8320152	20	BC 557B
3TR4	8320295	20	BC 337-25/18
3TR5	8320152	20	BC 557B
3TR6			
3TR7	8320295	20	BC 337-25/18
3TR8	8320097	20	BC 547B
3TR201	8320344	20	BC 550B
3TR202	8320323	19	MPS A05
4TR1	8320281	42	BF 199
4TR2			
4TR3	8320097	20	BC 547B
4TR4	8320152	20	BC 557B
4TR5	8320097	20	BC 547B
4TR6	8320241	32	BD 138/W
4TR7	8320097	20	BC 547B
4TR9			
6TR1	8320097	20	BC 547B
6TR2	8320540	20	BC 557C

6TR3	8320152	20	BC 557B
6TR4	8320542	43	BD 825
6TR5	8320541	43	BD 828
9TR1	8320097	20	BC 547B
9TR3			
9TR4	8320152	20	BC 557B
9TR5	8320097	20	BC 547B
12TR1	8320108	20	BC 548B
12TR21			
12TR24	8320285	20	BC 548C
		20	BC 183C/CL
		17	BC 183CL
12TR25	8320398	20	BC 548C
12TR26	8320285	20	BC 548C
		20	BC 183C/CL
		17	BC 183CL
121TR27	8320108	20	BC 548B
12TR28	8320104	20	BC 558B
12TR30			
12TR31	8320331	20	BC 328-25/18
12TR32	8320104	20	BC 558B
12TR33	8320331	20	BC 328-25/18
12TR34	8320108	20	BC 548B
12TR35			
12TR38			

12TR39	8320423	19	92 PU51
12TR40	8320108	20	BC 548B
12TR41	8320423	19	92 PU51
12TR42	8320108	20	BC 548B
12TR43	8320331	20	BC 328-25/18
12TR44	8320108	20	BC 548B
12TR45	8320331	20	BC 328-25/18
12TR46	8320108	20	BC 548B
12TR47	8320423	19	92PU51
12TR50	8320108	20	BC 548B
12TR51	8320104	20	BC 548B
12TR54			
12TR55	8320108	20	BC 548B
12TR56			
13TR1	8320398	20	BC 558C
14TR1	8320398	20	BC 558C

FOR SERVICE MANUALS

CONTACT:

**MAURITRON TECHNICAL SERVICES**

[www.mauritron.co.uk](http://www.mauritron.co.uk)

TEL: 01844 - 351694

FAX: 01844 - 352554

<b>19</b> 	<b>20</b> 	<b>31</b> 	<b>101</b> 	<b>102</b> 	<b>103</b> 	<b>124</b> 	<b>134</b> 
<b>135</b> 							

## List of IC's

11C1	8340490	101	TDA 1062S	31C201	8340054	19	MPS A13
11C2*	8340233	101	CA 3189E	41C1Δ	8340561	124	TMP 8355P
11C3	8340489	101	TDA 1072	41C2Δ	8340560	124	P8051
11C4	8340284	101	TDA 4500A	41C3	8340492	103	SP 8629
11C5Δ	8340224	103	TL 072CP	41C4Δ	8340109	102	MC 14011B
11C6						102	CD 4011CN
						102	CD 4011
11C7	8340025	19	SPS 5431			102	14011CP
		19	MPS A65				
		20	BC 516	41C5Δ	8340491	101	HEF4520
21C1	8340244	130	LM 317T	41C6Δ	8340378	101	MC 14017
21C3				41C7Δ	8340351	103	MC 144102
21C4	8340141	103	LM 741 CN	41C8			
21C200	8340470	31	BDV 65B	91C1	8340193	103	TDA 4050
21C201	8340469	31	BDV 64B	91C2	8340025	19	SPS 5431
21C202	8340400	19	MPSA 13 SP			19	MPS A65
						20	BC 516
31C1	8340468	101	TDA 1028	121C1Δ	8340559	134	μPD 650
31C2Δ	8340188	101	TDA 1029	121C2Δ	8340378	101	4017
31C3	8340187	111	TDA 1074				
31C4							
31C5Δ	8340467	124	MM 5450				

Δ betyder at statisk elektricitet kan ødelægge komponenten.  
 Δ indicates that static electricity may destroy the component.  
 Δ bedeutet, daß statische Elektrizität die Komponente zerstören kann.  
 Δ signifi que électricité statique peut detruire le composant.

- \* Speciel udvalgt eller bearbejdet eksemplar.
- \* Specially selected or adapted sample.
- \* Speziell ausgewähltes und bearbeitets Exemplar.

## LIST OF ELECTRICAL PARTS

OR1	5000194	3.3 M $\Omega$ 10% 1/2W			
OC1	4200421	1000 $\mu$ F -10+50% 63V	OC2	4130214	10 nF $\pm$ 20% 63V
F1	6600019	Fuse 2A-T/250	F1	6600019	Fuse 5A
AM/FM, 8002561, PCB1 (Type 2321, 2322, 2325)					
R1	5370074	10 k $\Omega$ 20% 0.1W	R82	5370058	5 k $\Omega$ 20% 0.1W
R2	5370061	47 k $\Omega$ 20% 0.1W	R85	5370074	10 k $\Omega$ 20% 0.1W
R3	5370061	47 k $\Omega$ 20% 0.1W	R92	5010733	5.1 k $\Omega$ 5% 1/4W
R4	5370061	47 k $\Omega$ 20% 0.1W	R93	5010733	5.1 k $\Omega$ 5% 1/4W
R5	5020342	750 $\Omega$ 1% 1/4W	R180	5020083	33.2 k $\Omega$ 1% 1/4W
R19	5020345	47 $\Omega$ 10% 1/4W	R183	5020110	10 k $\Omega$ 1% 1/4W
R50	5370061	47 k $\Omega$ 20% 0.1W	R191	5020255	63.4 k $\Omega$ 1% 1/4W
R51	5370074	10 k $\Omega$ 20% 0.1W	R197	5010839	6.8 k $\Omega$ 5% 1/8W
R68	5370068	22 k $\Omega$ 20% 0.1W			
C1	4000106	8.2 pF $\pm$ 0.25 pF 250V	C57	4130233	220 nF 20% 63V
C2	4010027	1 nF 10% 100V	C58	4200517	2.2 $\mu$ F 20% 50V
C3	4010024	470 pF 10% 100V	C59	4130213	10 nF 10% 63V
C4	4010027	1 nF 10% 100V	C60	4130213	10 nF 10% 63V
C5	4000104	4.7 pF $\pm$ 25 pF 63V	C61	4200510	10 $\mu$ F 20% 16V
C6	4010024	470 pF 10% 100V	C62	4000170	120 pF 2% 63V
C7	4000099	3.3 pF $\pm$ 0.25 pF 63V	C63	4003128	100 pF 5% 63V
C8	4011022	4.7 nF -20+80% 40V	C64	4201087	47 $\mu$ F -10+100% 40V
C9	4010024	470 pF 10% 100V	C65	4100216	3.9 nF 2.5% 63V
C10	4000105	5.6 pF $\pm$ 0.25 pF 63V	C66	4003124	56 pF 2% 63V
C11	4010087	470 pF 10% 63V	C67	4130233	200 nF 20% 63V
C12	4011022	4.7 nF -20+80% 40V	C68	4130233	220 nF 20% 63 V
C13	4010107	22 nF -20+100% 40V	C69	4130230	100 nF 20% 63V
C14	4003124	56 pF 2% 63V	C70	4010106	10 nF -20+80% 40V
C15	4000107	68 pF 2% 63V	C71	4010106	10 nF -20+80% 40V
C16	4200510	10 $\mu$ F 20% 16V	C72	4100033	3.3 nF 5% 63V
C17	4011022	4.7 nF -20+80% 40V	C73	4130230	100 nF 20% 63V
C18	4010106	10 nF -20+80% 40V	C74	4130230	100 nF 20% 63V
C19	4130233	220 nF 20% 63V	C75	4130230	100 nF 20% 63V
C20	4010027	1 nF 10% 100V	C76	4010103	2.2 nF 10% 63V
C21	4010087	470 pF 10% 63V	C77	4100033	3.3 nF 5% 63V
C22	4010107	22 nF -20+100% 40V	C78	4340003	5.5-65 pF folie
C23	4130233	220 nF 20% 63V	C79	4340002	2-22 pF foil
C24	4010106	10 nF -20+80% 40V	C80	4130233	220 nF 20% 63V
C25	4000082	3.9 pF $\pm$ 0.25 pF 63V	C81	4130233	220 nF 20% 63V
C26	4000110	82 pF 5% 63V	C82	4130234	470 nF 10% 63V
C27	4000069	100 pF 5% 63V	C83	4200517	2.2 $\mu$ F 20% 50V
C28	4100192	1.8 nF 5% 63V	C84	4003125	33 pF 2% 63V
C29	4003128	100 pF 5% 63V	C85	4000029	220 pF 5% 63V
C30	4003128	100 pF 5% 63V	C86	4101025	180 pF $\pm$ 2.5% 63V
C31	4200510	10 $\mu$ F 20% 16V	C87	4000081	18 pF 5% 63V
C32	4010106	10 nF -20+80% 40V	C88	4340003	5.5-65 pF folie
C33	4200510	10 $\mu$ F 20% 16V	C89	4001110	82 pF 5% 63V
C34	4200510	10 $\mu$ 20% 16V	C90	4340003	5.5-65 pF folie
C35	4003128	100 pF 5% 63V	C91	4132033	220 nF 20% 63V
C36	4200517	2.2 $\mu$ F 20% 50V	C92	4130233	220 nF 20% 63V
C37	4010106	10 nF -20+80% 40V	C93	4130233	220 nF 20% 63V
C38	4000170	120 pF 2% 63V	C94	4200525	22 $\mu$ F 20% 10V
C39	4000029	220 pF 5% 63V	C95	4200517	2.2 $\mu$ F 20% 50V
C40	4010106	10 nF -20+80% 40V	C96	4010106	10 nF -20+80% 40V
C41	4130230	100 nF 20% 63V	C97	4010027	1 nF 10% 100V
C42	4130230	100 nF 20% 63V	C100	4000077	47 pF 2% 63 V
C43	4010106	10 nF -20+80% 40V	C101	4010107	22 nF -20+100% 40V
C44	4010106	10 nF -20+80% 40V	C102	4010107	22 nF -20+100% 40V
C45	4010106	10 nF -20+80% 40V	C103	4130136	1 $\mu$ F 20% 100V
C46	4130230	100 nF 20% 63V	C104	4010106	10 nF -20+80% 40V
C49	4130233	220 nF 20% 63V	C105	4000016	10 pF 2% 63V
C50	4200403	100 $\mu$ F -10+100% 25V	C106	4200510	10 $\mu$ F 20% 16V
C51	4130234	470 nF 10% 63V	C107	4130233	220 nF 20% 63V
C52	4130233	220 nF 20% 63V	C201	4100081	2.15 nF 2.5% 63V
C53	4000029	220 pF 5% 63V	C202	4100077	196 pF 2.5% 63V
C54	4200517	2.2 $\mu$ F 20% 50V	C203	4100078	4.02 nF 2.5% 63V
C55	4010106	10 nF -20+80% 40V	C204	4100080	866 pF 2.5% 63V
C56	4000029	220 pF 5% 63V	C205	4100079	590 pF 2.5% 63V

FOR SERVICE MANUALS  
CONTACT:  
**MAURITRON TECHNICAL SERVICES**  
www.mauritron.co.uk  
TEL: 01844 - 351694  
FAX: 01844 - 352554



C401	4100081	2.15 nF 2.5% 63 V	C404	4100080	866 pF 2.5% 63 V
C402	4100077	196 pF 2.5% 63 V	C405	4100079	590 pF 2.5% 63 V
C403	4100078	4.02 nF 2.5% 63 V			

BP1	8030040	10.7 MHz	BP3	8030040	10.7 MHz
	8030037	Only type 2329		8030037	Only type 2329
BP2	8030040	10.7 MHz	BP4	8030025	460 kHz $\pm$ 1 kHz
	8030037	Only type 2329			

L1	8020322	OSC	L12	8020414	Coil LW
L2	8020321	RF	L13	8020416	Coil MW
L3	8020320	RF coil	L14	8020417	Coil OSC MW
L4	8020319	Aerial coil	L15	8020415	Coil OSC LW
L6	8020323	IF	L16	8020471	Coil 460 kHz
L7	8020368	IF	L200	8022079	Coil LF 78 mH
L8	8020419	Coil AFC 460 kHz	L201	8022079	Coil LF 78 mH
L9	8020369	IR	L400	8022079	Coil LF 78 mH
L10	8020413	Coil 1 mH	L401	8022079	Coil LF 78 mH
L11	8020418	Coil 460 kHz			

P1	7220219	Plug 2x10/10	3304014	Screen/housing
P2	7220313	Plug 3/3	3304017	Screen/housing
P3	7220212	Plug 3/3	3304098	Screen/housing
P4	7220312	Plug 2/2	3304102	Screen/housing
P5	7220279	Plug 2/2		

AM/FM, 8002141, PCB1  
Type 2323

C59	4130275	15 nF 2.5% 63V	C60	4130275	15 nF 2.5% 63V
-----	---------	----------------	-----	---------	----------------

AM/FM 8002140, PCB1  
Type 2324

R197	5010839	6.8 k $\Omega$ 5% 1/8W
------	---------	------------------------

AM/FM 8002145, PCB1  
Type 2329

C108	4100222	680 pF 2.5% 63V	C109	4130234	470 nF 10% 63V
L17	8020413	Coil 1 mH			

*Øvrige komponenter som i styklisten for PCB1, 8002561  
Other components in parts list for PCB1, 8002561*

Båndpasfiltrene 1BP1, 2 og 3 skal være forsynede med ens farvemærkning, og udleveres derfor fra reservedelslageret i sæt af 3 stk. Ved udskiftning til filtre med anden farvekode end de monterede, skal displayets frekvensudlæsning korrigeres iflg. nedenstående procedure: Tryk **[MANUEL]**.

Tryk **[SELECT]**, samtidig trykkes på **[TAPE 1]**, begge knapper holdes nede.

Displayet viser først P, kort efter skifter display til frekvensen.

Ved gentagne tryk på **[ $\nabla$  VOLUME]** eller **[ $\Delta$  VOLUME]** kan frekvensudlæsningen ændres til mindre henholdsvis større frekvens. Displayet justeres til korrekt visning.

The band-pass filters 1BP1, 2 and 3 must have identical colour marking, and are therefore delivered from the spareparts stock in sets of 3 units.

When replacing filters of different colour code than those mounted, the frequency reading must be corrected as to the following procedure:

Press **[MANUEL]**.

Press **[SELECT]**, and simultaneously press **[TAPE 1]**, both buttons are held down. The display will first indicate P, shortly after the display will switch to the frequency.

By repeated pressing on **[ $\nabla$  VOLUME]** or **[ $\Delta$  VOLUME]** the frequency reading changes to lower respectively higher frequency. The display is adjusted to correct indication.

Output Amplifier and  
Power Supply 8002553,  
PCB2

R6	5010065	10 Ω 5% 1/4W	R206	5011037	3.3 kΩ 5% 1/2W
R15	5370058	4.7 kΩ 20% 0.1W	R211	5010797	390 Ω 2% 1/4W
R21	5020110	10 kΩ 1% 1/4W	R213	5020110	10 kΩ 1% 1/4W
R22	5020110	10 kΩ 1% 1/4W	R214	5020110	10 kΩ 1% 1/4W
R25	5020222	6.04 kΩ 1% 1/4W	R215	5020633	150 Ω 5% 1/4W
R26	5020533	402 Ω 1% 1/4W	R226	5370240	100 Ω 20% 0.1W
R40	5220036	330 kΩ 10% 1/2W	R228	5102016	0.22 Ω 10% 1/4W
R50	5220036	330 kΩ 10% 1/2W	R229	5102016	0.22 Ω 10% 1/4W
R201	5020153	41.2 kΩ 1% 1/4W	R231	5010765	4.7 Ω 5% 1/2W
R202	5020110	10 kΩ 1% 1/4W			

C1	4130103	100 nF 20% 250V	C18	4130171	330 nF 20% 63V
C2	4130103	100 nF 20% 250V	C20	4010063	4.7 nF 10% 63V
C3	4130280	220 nF 20% 100V	C200	4200368	100µF -10+100% 63V
C4	4130280	220 nF 20% 100V	C201	4130214	10 nF 20% 63V
C5	4130280	220 nF 20% 100V	C202	4130228	470 nF 20% 63V
C6	4200530	1000µF-20+50% 50V	C203	4000092	180 pF 5% 63V
C7	4200530	1000µF-20+50% 50V	C204	4010063	4.7 nF 10% 63V
C8	4200368	100µF-10+100% 63V	C205	4200478	100 µF 20% 10V
C9	4010063	4.7 nF 10% 63V	C206	4200478	100 µF 20% 10V
C10	4200380	1 µF -10+50% 63V	C207	4000026	22 pF 2% 63V
C11	4130179	100 nF 20% 63V	C208	4003130	47 pF 2% 63V
C12	4130179	100 nF 20% 63V	C209	4130193	22 nF 20% 63V
C13	4200417	4700 µF -10+50% 16V	C210	4130215	220 nF 20% 63V
C14	4130179	100 nF 20% 63V	C211	4130215	220 nF 20% 63V
C15	4000016	10 pF 2% 63V	C212	4130215	220 nF 20% 63V
C16	4130179	100 nF 20% 63V	C213	4200431	10 µF 20% 16V
C17	4130193	22 nF 20% 63V			

FOR SERVICE MANUALS  
CONTACT:  
MAURITRON TECHNICAL SERVICES

www.mauritron.co.uk  
TEL: 01844 - 351694  
FAX: 01844 - 352554

L200 6850114 Coil 0.5 µH

F1 6600010 Fuse 4A-T/250 V

RL1 7600046 Relay 6 V

P17	7220160	Plug 5/4 pins	P20	7220195	Plug 2/2 pins
P18	7220139	Plug 11/12 pins	P21	7220185	Plug 3/3 pins
P19	7220320	Plug 7/7 pins			

Preamplifier, 8002186, PCB3

R7	5020515	887 kΩ 1% 1/4W	R39	5020455	470 Ω 5% 1W
R8	5020517	442 kΩ 1% 1/4W	R43	5020455	470 Ω 5% 1W
R9	5020518	221 kΩ 1% 1/4W	R50	5020455	470 Ω 5% 1W
R10	5020265	110 kΩ 1% 1/4W	R229	5370150	470 Ω 20% 0.1W
R11	5370061	47 kΩ 20% 0.1W	R231	5020075	36.5 kΩ 1% 1/4W
R14	5020188	1 kΩ 1% 1/4W	R232	5020456	200 kΩ 1% 1/4W
R20	5370061	47 kΩ 20% 0.1W	R241	5370068	22 Ω 20% 0.1W
R23	5020188	1 kΩ 1% 1/4W	R243	5020574	698 Ω 1% 1/4W
R24	5020515	887 kΩ 1% 1/4W	R244	5020515	887 kΩ 1% 1/4W
R25	5020517	442 kΩ 1% 1/4W	R245	5020517	442 kΩ 1% 1/4W
R26	5020518	221 kΩ 1% 1/4W	R246	5020518	221 kΩ 1% 1/4W
R27	5020265	110 kΩ 1% 1/4W	R247	5020265	110 kΩ 1% 1/4W
R38	5020455	470 Ω 5% 1W	R248	5020254	54.9 kΩ 1% 1/4W

C1	4200403	100µF-10+100%25V	C200	4130233	220 nF 20% 63V
C2	4130230	100 nF 20% 63V	C201	4000139	100 pF 5% 63V
C3	4010107	22 nF -20+100% 40V	C202	4130233	220 nF 20% 63V
C4	4201087	47µF -10+100% 40V	C203	4000139	100 pF 5% 63V
C5	4010101	4.7 nF 10% 63V	C204	4200510	10 µF 20% 16V
C6	4200403	100µF-10+100%25V	C205	4130236	330 nF 20% 63V
C7	4130230	100 nF 20% 63V	C207	4130233	220 nF 20% 63V
C8	4200518	22 µF -10+100% 16V	C208	4000139	100 pF 5% 63 V
C9	4200510	10 µF 20% 16V	C209	4130233	220 nF 20% 63 V
C11	4200403	100µF-10+100%25V	C210	4000139	100 pF 5% 63 V
C12	4200518	22µF -10+100% 16V	C211	4130233	220 nF 20% 63 V
C14	4130230	100 nF 20% 63V	C212	4000139	100 pF 5% 63 V
C15	4010105	1 nF 10% 100V	C213	4000150	68 pF 5% 63 V
C16	4010105	1 nF 10% 100 V	C214	4200517	2.2 µF 20% 50 V
C18	4200551	33 µF 20% 16 V	C215	4010104	220 pF 10% 250 V

C216	4130231	68 nF 10% 63V	C230	4010103	2.2 nF 10% 63V
C217	4010065	2.7 nF 10% 63V	C231	4200518	22 $\mu$ F -10+100% 16V
C218	4130241	10 nF 20% 63V	C232	4130235	47 nF 20% 63V
C222	4200510	10 $\mu$ F 20% 16V	C233	4200518	22 $\mu$ F -10+100% 16V
C223	4000137	47 pF 5% 63V	C234	4010103	2.2 nF 10% 63V
C224	4200510	10 $\mu$ F 20% 16V	C235	4200510	10 $\mu$ F 20% 16V
C225	4200518	22 $\mu$ F -10+100% 16V	C236	4010122	680 pF 10% 63V
C228	4200518	22 $\mu$ F -10+100% 16V	C237	4130235	47 nF 20% 63V
C229	4010103	2.2 nF 10% 63V	C238	4200510	10 $\mu$ F 20% 16V

---

RL1 7600046 Relay 6V

---

P6	7220114	Plug 5/4 pins	P13	7220116	Plug 8/7 pins
P7	7220210	Plug 4/4 pins	P14	7220122	Plug 4/3 pins
P8	7220122	Plug 4/3 pins	P14	7220129	Plug 2/2 pins
P9	7220128	Plug 6/5 pins	P16	7220144	Plug 5/4 pins
P10	7220122	Plug 4/3 pins		7220272	Connector 13/13
P11	7220124	Plug 9/8 pins		7220230	Connector 5/5
P12	7220117	Plug 12/11 pins		7220178	Connector 10/10

---

### Microcomputer, 8002554, PCB4

R1	5030001	8 x 22 k $\Omega$ 5% 1/8W	R14	5010816	1 k $\Omega$ 5% 1/8W
R2	5010816	1 k $\Omega$ 5% 1/8W	R55	5010886	220 $\Omega$ 5% 1/8W
R3	5010816	1 k $\Omega$ 5% 1/8W	R56	5010886	220 $\Omega$ 5% 1/8W
R4	5010816	1 k $\Omega$ 5% 1/8W	R57	5010886	220 $\Omega$ 5% 1/8W
R5	5010816	1 k $\Omega$ 5% 1/8W	R58	5010816	1 k $\Omega$ 5% 1/8W
R6	5010816	1 k $\Omega$ 5% 1/8W	R59	5010816	1 k $\Omega$ 5% 1/8W
R7	5010816	1 k $\Omega$ 5% 1/8W	R60	5010816	1 k $\Omega$ 5% 1/8W
R8	5010816	1 k $\Omega$ 5% 1/8W	R61	5010816	1 k $\Omega$ 5% 1/8W
R9	5010816	1 k $\Omega$ 5% 1/8W	R62	5010816	1 k $\Omega$ 5% 1/8W
R10	5010816	1 k $\Omega$ 5% 1/8W	R63	5010816	1 k $\Omega$ 5% 1/8W
R11	5010816	1 k $\Omega$ 5% 1/8W	R64	5010816	1 k $\Omega$ 5% 1/8W
R12	5010885	5.6 k $\Omega$ 5% 1/8W	R65	5010885	5.6 k $\Omega$ 5% 1/8W
R13	5010816	1 k $\Omega$ 5% 1/8W	R66	5010885	5.6 k $\Omega$ 5% 1/8W

---

FOR SERVICE MANUALS  
CONTACT:  
**MAURITRON TECHNICAL SERVICES**  
www.mauritron.co.uk  
TEL: 01844 - 351694  
FAX: 01844 - 352554

C1	4010027	1 nF 10% 100V	C35	4000110	82 pF 5% 63V
C2	4010027	1 nF 10% 100V	C36	4010027	1 nF 10% 100V
C3	4010027	1 nF 10% 100V	C37	4010027	1 nF 10% 100V
C4	4010027	1 nF 10% 100V	C38	4200396	220 $\mu$ F 16V
C5	4010027	1 nF 10% 100V	C39	4000076	18 pF 2% 63V
C6	4010027	1 nF 10% 100V	C40	4000076	18 pF 2% 63V
C7	4010027	1 nF 10% 100V	C45	4010027	1 nF 10% 100V
C8	4010027	1 nF 10% 100V	C46	4010027	1 nF 10% 100V
C9	4010027	1 nF 10% 100V	C47	4010027	1 nF 10% 100V
C10	4010027	1 nF 10% 100V	C48	4010027	1 nF 10% 100V
C11	4010027	1 nF 10% 100V	C49	4010027	1 nF 10% 100V
C18	4010027	1 nF 10% 100 V	C50	4010027	1 nF 10% 100V
C19	4010027	1 nF 10% 100 V	C51	4010027	1 nF 10% 100V
C20	4010027	1 nF 10% 100 V	C52	4010027	1 nF 10% 100V
C21	4010024	470 pF 10% 100V	C53	4010027	1 nF 10% 100V
C22	4010027	1 nF 10% 100V	C54	4010027	1 nF 10% 100V
C23	4130179	100 nF 20% 63V	C55	4010027	1 nF 10% 100V
C24	4010027	1 nF 10% 100V	C56	4010027	1 nF 10% 100V
C25	4130179	100 nF 20% 63V	C57	4010027	1 nF 10% 100V
C26	4010027	1 nF 10% 100V	C58	4010027	1 nF 10% 100V
C27	4010060	22 nF -20+80% 40V	C59	4200414	33 $\mu$ F -10+50% 16V
C28	4010060	22 nF -20+80% 40V	C65	4200539	100 $\mu$ F -10+50% 6.3V
C29	4010027	1 nF 10% 100V	C66	4130254	470 nF 20% 63V
C30	4010027	1 nF 10% 100V	C67	4100019	1 nF 2.5% 63V
C31	4010027	1 nF 10% 100V	C68	4200330	100 $\mu$ F -10+50% 10V
C32	4100146	2.2 nF 2.5% 63V	C60	4130179	100 nF 20% 63V
C33	4010027	1 nF 10% 100V	C70	4130179	100 nF 20% 63V
C34	4010062	330 pF 10% 100V	C71	4130254	470 nF 20% 63V

---

X1 8030023 400 kHz  $\pm$ 1 kHz X2 8090005 8.8672 M  $\pm$ 20 ppm

---

L1	8020341	Aerial transformer	L4	8020085	10 $\mu$ H
L2	8020342	10 $\mu$ H	L5	8020085	10 $\mu$ H
L3	8020085	10 $\mu$ H	L6	8020085	10 $\mu$ H

L7	8020342	10 $\mu$ H	L9	8020413	1 mH MF/AM
L8	8020085	10 $\mu$ H			
P22	7220115	Plug 7/6 pins	8700012	Battery	
P23	7220320	Plug 7/7 pins	3302356	Frame for $\mu$ c-box	
P24	7220129	Plug 2/2 pins	3302355	Lid for $\mu$ c-box	
P25	7220129	Plug 2/2 pins			
P26	7220321	Plug 18/18 pins			
P27	7220323	Plug 15/15 pins			
<b>Keyboard, 8002576, PCB5</b>					
P30	7220355	Plug 9/9 pins			
<b>Fan regulation, 8002173, PCB6</b>					
R3	5020577	8.25 k $\Omega$ 1% 1/4W	R5	5230012	15 $\Omega$ $\pm$ 20% 1/8W
C1	4010041	10 nF -20+80% 40V	C5	4130210	47 nF 20% 63V
C2	4130259	220 nF 1% 160V	C6	4200542	68 $\mu$ F 20% 63V
C3	4130210	47 nF 20% 63V	C7	4200304	470 $\mu$ F -10+100%40V
C4	4010027	1 n $\pm$ 10% 100V			
	3358186	Heatsink			
<b>Display-Right, 8002556, PCB7</b>					
P32	7220238	Plug 8/8 pins			
<b>RF-Level Adjustment, 8002600, PCB10</b>					
R1	5370068	22 k $\Omega$ 20% 0.1W	R2	5370068	22 k $\Omega$ 20% 0.1W
P33	7220310	Plug 3/3 pins			
<b>Remote Control, 8002557, PCB9</b>					
C1	4200488	22 $\mu$ F $\pm$ 20% 25V	C7	4200423	2.2 $\mu$ F $\pm$ 20% 50V
C2	4000029	220 pF $\pm$ 5% 63V	C8	4100033	3.3 nF $\pm$ 5% 63V
C3	4010060	22 nF -20+80% 40V	C9	4010067	1.5 nF $\pm$ 10% 63V
C4	4010041	10 nF -20+80% 40V	C10	4010067	1.5 nF $\pm$ 10% 63V
C5	4200431	10 $\mu$ F $\pm$ 20% 16V	C11	4200431	10 $\mu$ F 20% 16V
C6	4200423	2.2 $\mu$ F $\pm$ 20% 50V	C13	4010041	10 nF -20+80% 40V
L1	8022128	Coil 55 mH			
<b>Terminal Microcomputer, 8002579, PCB12</b>					
R84	5020625	2.7 $\Omega$ $\pm$ 5% 0.3W	R155	5370191	10 k $\Omega$ $\pm$ 20% 0.1 W
R86	5020625	2.7 $\Omega$ $\pm$ 5% 0.3V			
C1	4200342	10 pF -10+50% 63V	C19	4000171	82 pF $\pm$ 2% 63V
C2	4010027	1 nF $\pm$ 10% 100V	C20	4010027	1 nF $\pm$ 10% 100V
C3	4130215	220 nF $\pm$ 20% 63V	C21	4130223	47 nF $\pm$ 10% 63V
C4	4200364	47 $\mu$ F -10+50% 10V	C25	4010041	10 nF -20+80% 40V
C5	4010063	4.7 nF $\pm$ 10% 63V	C26	4010041	10 nF -20+80% 40V
C6	4010061	2.2 nF $\pm$ 10% 63V	C27	4010041	10 nF -20+80% 40V
C7	4010031	680 pF $\pm$ 10% 100V	C28	4010041	10 nF -20+80% 40V
C8	4200342	10 $\mu$ F -10+50% 63V	C29	4010041	10 nF -20+80% 40V
C9	4010061	2.2 nF $\pm$ 10% 63V	C30	4200396	220 $\mu$ F 16V
C10	4010027	1 nF $\pm$ 10% 100V	C31	4130223	47 nF $\pm$ 10% 63V
C11	4010062	330 pF $\pm$ 10% 100V	C32	4130215	220 nF $\pm$ 20% 63V
C12	4130237	680 nF $\pm$ 20% 63V	C33	4130225	150 nF $\pm$ 10% 63V
C15	4010041	10 nF -20+80% 40V	C34	4200426	1 $\mu$ F $\pm$ 20% 50V
C16	4130179	100 nF $\pm$ 20% 63V	C35	4130223	47 nF $\pm$ 10% 63V
C17	4010041	10 nF -20+80% 40V	C36	4130228	470 nF $\pm$ 20% 63V
C18	4010062	330 pF $\pm$ 10% 100V			
L1	8020342	Coil 10 $\mu$ H			
X1	8030038	400 kHz $\pm$ 1 kHz	3302357	Screen/housing	

Master control IR – Left,  
8002634, PCB13

R1	5010839	6.8 k $\Omega$ $\pm$ 5% 1/8W			
C1	4010041	10 nF -20+80% 40 V	C3	4340018	10-60 pF
C2	4000018	220 pF $\pm$ 5% 63 V	C4	4003135	39 pF $\pm$ 5% 63 V
L1	8022138	Coil 54 MHz $\pm$ 10%			
P35	7220344	Plug 5/4			
	3304105	Screen			
	3304106	Screen			

Master control IR – Right,  
8002633, PCB14

R1	5010839	6.8 k $\Omega$ $\pm$ 5% 1/8W			
C1	4010041	10 nF -20+80% 40V	C3	4340018	10-60 pF
C2	4000018	220 pF $\pm$ 5% 63V	C4	4003135	39 pF $\pm$ 5% 63V
L1	8022138	Coil 54 MHz $\pm$ 10%			
P36	7220344	Plug 5/4			
	3304105	Screen			
	3304106	Screen			

Modstande som ikke er nævnt i elektrisk stykliste er 5% 1/4 W kulfilm.

Resistors not mentioned in the electrical parts list are 5% 1/4 W carbon film.

Widerstände die nicht in der elektrischen Stückliste erwähnt sind, sind 5% 1/4 W Kohlenfilm.

Resistances pad mentionés dans la liste des composants, sont 5% 1/4 W films de carbon.

FOR SERVICE MANUALS  
CONTACT:  
**MAURITRON TECHNICAL SERVICES**  
[www.mauritron.co.uk](http://www.mauritron.co.uk)  
TEL: 01844 - 351694  
FAX: 01844 - 352554

MEKANISK STYKLISTE/  
MECHANICAL PARTS LIST

001	2039020	Skrue AM 3 x 5	Screw AM 3 x 5
002	2039020	Skrue AM 3 x 5	Screw AM 3 x 5
003	2039020	Skrue AM 3 x 5	Screw AM 3 x 5
004	2039020	Skrue AM 3 x 5	Screw AM 3 x 5
005	2039026	Skrue AM 3 x 4	Screw AM 3 x 4
006	2622016	Skive 3.2	Washer 3.2
0010	2810088	Fjeder	Spring
0011	2810085	Fjeder	Spring
0012	3151215	Eject samlet	Eject assembled
0013	2039020	Skrue AM 3 x 5	Screw AM 3 x 5
0014	2625002	Skive	Washer
0016	2039030	Skrue AM 3 x 10	Screw AM 3 x 10
0017	2038206	Bøsning	Bushing
0018	2039020	Skrue AM 3 x 5	Screw AM 3 x 5
0019	2036036	Skrue AM 2,5 x 4	Screw AM 2.5 x 4
0020	2542506	Dæmpe vinkel	Damping bracket
0021	2810152	Fjeder	Spring
0022	2992021	Tap	Tap
0023	2724046	Snortrisse	Cord pulley
0024	3131211	Hus	Housing
0025	2039020	Skrue AM 3 x 5	Screw AM 3 x 5
0026	2039020	Skrue AM 3 x 5	Screw AM 3 x 5
0027	2015913	Skrue M 3,5 x 9,5	Screw M 3.5 x 9.5
0028	2938205	Bøsning	Bushing
0029	3152367	Leningsholder	Cable fastener
0030	3152366	Ledningsholder	Cable fastener
0031	3454298	Chassisramme	Chassis frame
0032	2819174	Fjeder	Spring
0033	8002577	PCB hovedtelefon med stik	PCB headphone with plug
0034	2380092	Møtrik for Jack-stik	Nut for Jack socket
0035	3454297	Bund	Bottom
0036	2039020	Skrue AM 3 x 5	Screw AM 3 x 5
0037	2043020	Skrue AM 4 x 6	Screw AM 4 x 6
0038	3035119	Gummifod	Rubber foot
0039	2043011	Skrue AM 4 x 8	Screw AM 4 x 8
0040	2622304	Skive	Washer
0041	2391059	Låseplade	Locking plate
0042	3413008	Kabinet, aluminium	Cabinet, aluminium
	3413973	Kabinet, palis	Cabinet, rosewood
0043	2039020	Skrue AM 3 x 5	Screw AM 3 x 5
0044	8002164	PCB mont. sikring, type 2321	PCB mount. fuse, type 2321
	8002589	PCB mont. sikring, type 2323	PCB mount. fuse, type 2323
	8002590	PCB mont. sikring, type 2324	PCB mount. fuse, type 2324
0045	2043003	Skrue AM 4 x 25	Screw AM 4 x 25
0046	2938154	Bøsning	Bushing
0047	3152341	Holder	Holder
0048	2938154	Bøsning	Bushing
0049	2834084	Aksel	Shaft
0050	3014060	Styr	Guide
0051	2039020	Skrue AM 3 x 5	Screw AM 3 x 5
0052	2622117	Skive 3.2	Washer 3.2
0053	3150053	Leje	Bearing
0054	2013107	Skrue M 2,9 x 9,5	Screw M 2.9 x 9.5
0055	2039027	Skrue AM 3 x 6	Screw AM 3 x 6
0056	2622041	Skive 3.2	Washer 3.2
0057	3131220	Display hus	Display housing

FOR SERVICE MANUALS  
CONTACT:  
MAURITRON TECHNICAL SERVICES

[www.mauritron.co.uk](http://www.mauritron.co.uk)  
TEL: 01844 - 351694  
FAX: 01844 - 352554

OT1	8013297	Transformator for type 2321	Transformer for type 2321
	8013299	Transformator for type 2323 med print	Transformer for type 2323 with print
	8013300	Transformator for type 2324 med print	Transformer for type 2324 with print
	3170000	Isolations stykke	Insulation piece
OM1	8410011	Blæser komplet	Fan complete
ODP1	8330091	Display	Display

0RL1	6840279 Sugespole	Magnet coil
0P2	6274110 P2/P24 med ledning	P2/P24 with cable
0P4	6274109 P4/P25 med ledning	P4/P25 with cable
0P24	6274110 P24/P2 med ledning	P24/P2 with cable
0P25	6274109 P25/P4 med ledning	P25/P4 with cable
0P9	6275512 Ledningssæt med fatning	Set of wires with socket
0P15	6275534 Ledningssæt med fatning	Set of wires with socket
0P20	6275507 Ledningssæt med fatning	Set of wires with socket
0P21	6275507 Ledningssæt med fatning	Set of wires with socket
01Modul	8002561 PCB. AM/FM - type 2321	PCB. AM/FM - type 2321
	8002141 PCB. AM/FM - type 2323	PCB. AM/FM - type 2323
	8002145 PCB. AM/FM - type 2329	PCB. AM/FM - type 2329
0101	2039020 Skruer AM 3 x 5	Screw AM 3 x 5
0102	2566047 Skinne	Rail
0103	2815007 Bladfjeder	Leaf spring
02Modul	8002553 PCB. Udgang og netdel	PCB. Output and power supply
0201	2568679 Køleprofil	Heatsink
0202	2011023 Skruer 2,2 x 6,6	Screw 2.2 x 6.6
0203	6140921 Print	PCB board
0204	2819175 Fjeder	Spring
0205	3170001 Glimmerskive T0-220	Mica sheet T0-220
	2622231 Glimmerskive T0-126	Mica sheet T0-126
0206	2819175 Fjeder	Spring
0207	2622014 Skive $\varnothing$ 3,2	Washer $\varnothing$ 3.2
0208	2013107 Skruer 2,9 x 6,5	Screw 2.9 x 6.5
0209	2560123 Skinne	Rail
02P6	6275509 Ledningssæt med fatning	Set of wires with socket
02P10	6275506 Ledningssæt med fatning	Set of wires with socket
03Modul	8002186 PCB. Indgang	PCB. Preamplifier
0301	2510134 Kortslutningsbøjle	Shortcircuit bracket
0302	7210378 Stikdåse »HØJTALER«	Socket »LOUDSPEAKER«
0303	7210269 Stikdåse 7 pol.	Socket 7 pole
0304	7210273 Stikdåse 2 pol	Socket 2 pole
0305	2382009 Fingermøtrik	Milled nut
0306	7210153 Stikdåse »AM«	Socket »AM«
0307	7210279 Stikdåse »FM«	Socket »FM«
0308	2039028 Skruer AM 3 x 8	Screw AM 3 x 8
0309	8002552 Stikpanel kompl.	Socket panel compl.
0310	3014059 Styr	Guide
0311	2039027 Skruer AM 3 x 6	Screw AM 3 x 6
0312	2365104 Nitte $\varnothing$ 2	Rivet $\varnothing$ 2
0313	7210001 Stikdåse netdel	Socket power supply
03P3	6274106 Ledningssæt med fatning	Set of wires with socket
03P5	7210326 Fatning/hus 2/2 pol	Socket/housing 2/2 pol
	7500161 Crimp kont.	Crimp cont.
04Modul	8002554 PCB. Microcomputer	PCB. Microcomputer
05Modul	3168230 Betjeningspanel kompl.	Operating panel compl.
0501	3168357 Panel	Panel
0502	3168219 Underpart	Bottom part
0503	2390001 Skive $\varnothing$ 2,3	Washer $\varnothing$ 2.3
0504	2812095 Fjeder	Spring
0505	2819171 Fjeder	Spring
0506	2568761 Profil	Profile
0507	2380011 Møtrik	Nut
0508	2622041 Skive $\varnothing$ 3,2	Washer $\varnothing$ 3.2
0509	2620020 Skive $\varnothing$ 3,2	Washer $\varnothing$ 3.2
0510	3150054 Leje	Bearing
0511	3947152 Tape - sort	Tape - black
0512	8002576 PCB. Betjening	PCB. Operating
0513	2775875 Knapsæt	Set of buttons
0514	7500148 Kontaktfjeder	Contact spring
0515	3947153 Tape - sort	Tape - black
	6200048 Båndkabel	Band cable

06	Modul 8002173 PCB. Motorstyring	PCB. Fan regulation
06	P17 6275505 Ledningssæt med fatning	Set of wires with socket
07	Modul 8002556 PCB. Display – højre	PCB. Display – right
08	Modul 8002555 PCB. Display – venstre	PCB. Display – left
08	P14 6275503 Ledningssæt med fatning	Set of wires with socket
09	Modul 8002557 PCB. Fjernbetjening – modtager	PCB. Remote control – receiver
09	P22 6275504 Ledningssæt med fatning	Set of wires with socket
10	Modul 8002600 PCB. HF justering	PCB. RF Level adjustment
20	Modul 6775511 Hovedledningsbundt	Main cable bundle
20	P1 7210401 Fatning/hus 20/20 pol	Socket/housing 20/20 pole
20	P7 7210259 Fatning/hus 4/4 pol	Socket/housing 4/4 pole
20	P8 7210405 Fatning/hus 4/3 pol	Socket/housing 4/3 pole
20	P11 7210421 Fatning/hus 9/8 pol	Socket/housing 9/8 pole
20	P12 7210420 Fatning/hus 12/11 pol	Socket/housing 12/11 pole
20	P13 7210424 Fatning/hus 8/7 pol	Socket/housing 8/7 pole
20	P18 7210422 Fatning/hus 11/10 pol	Socket/housing 10/11 pole
20	P19 7210262 Fatning/hus 7/7 pol	Socket/housing 7/7 pole
20	P23 7210423 Fatning/hus 7/7 pol	Socket/housing 7/7 pole
20	P26 7210402 Fatning/hus 18/18 pol	Socket/housing 18/18 pole
20	P28 7210403 Fatning/hus 15/15 pol	Socket/housing 15/15 pole
20	P30 7210264 Fatning/hus 9/9 pol	Socket/housing 9/9 pole
20	P31 7210404 Fatning/hus 11/11 pol	Socket/housing 11/11 pole
20	P32 7210263 Fatning/hus 8/8 pol	Socket/housing 8/8 pole
20	P33 7210258 Fatning/hus 3/3 pol	Socket/housing 3/3 pole

Ikke viste dele/  
Parts not shown

**FOR SERVICE MANUALS  
CONTACT:  
MAURITRON TECHNICAL SERVICES**  
www.mauritron.co.uk  
TEL: 01844 - 351694  
FAX: 01844 - 352554

3532157	Diagram	Diagram
3397443	Skumemballage sæt for Beomaster	Foam packing set for Beomaster
3391251	Yderæske for Beomaster	Outer carton for Beomaster
3397495	Skumemballage sæt, for Master Control	Foam packing set for Master Control
3391273	Yderæske for Master Control	Outer carton for Master Control
3391687	Papindlæg for Master Control	Carton insert for Master Control
3391630	Emballage for Beomaster Terminal	Packing for Beomaster Terminal
6271115	Netledning m/eurostik	Mains cable with Euro plug
6270251	Netledning for type 2323	Mains cable for type 2323
6271119	Netledning for type 2324	Mains cable for type 2324
6271091	Netledning for type 2325	Mains cable for type 2325
3414040	Kabinets finer, sæt alu.	Cabinet veneer, set alu.
3414043	Kabinets finer, sæt palis.	Cabinet veneer, set rosewood
3502488	Betjeningsanv. for 2321 DK	Operating manual for 2321 DK
3502489	Betjeningsanv. for 2321 S	Operating manual for 2321 S
3502490	Betjeningsanv. for 23221 SF	Operating manual for 2321 SF
3502491	Betjeningsanv. for 2321 GB	Operating manual for 2321 GB
3502492	Betjeningsanv. for 2321 D	Operating manual for 2321 D
3502493	Betjeningsanv. for 2321 F	Operating manual for 2321 F
3502494	Betjeningsanv. for 2321 NL	Operating manual for 2321 NL
3502495	Betjeningsanv. for 2323 USA	Operating manual for 2323 USA
3502496	Betjeningsanv. for 2038 DK	Operating manual for 2038 DK
3502497	Betjeningsanv. for 2038 S	Operating manual for 2038 S
3502498	Betjeningsanv. for 2038 SF	Operating manual for 2038 SF
3502499	Betjeningsanv. for 2038 GB	Operating manual for 2038 GB
3502500	Betjeningsanv. for 2038 D	Operating manual for 2038 D
3502501	Betjeningsanv. for 2038 F	Operating manual for 2038 F
3502502	Betjeningsanv. for 2038 NL	Operating manual for 2038 NL
3502503	Betjeningsanv. for 2038 USA	Operating manual for 2038 USA



# Bang & Olufsen

BEOMASTER 5000  
TYPE 2321

FOR SERVICE MANUALS  
CONTACT:  
**MAURITRON TECHNICAL SERVICES**

[www.mauritron.co.uk](http://www.mauritron.co.uk)  
TEL: 01844 - 351694  
FAX: 01844 - 352554

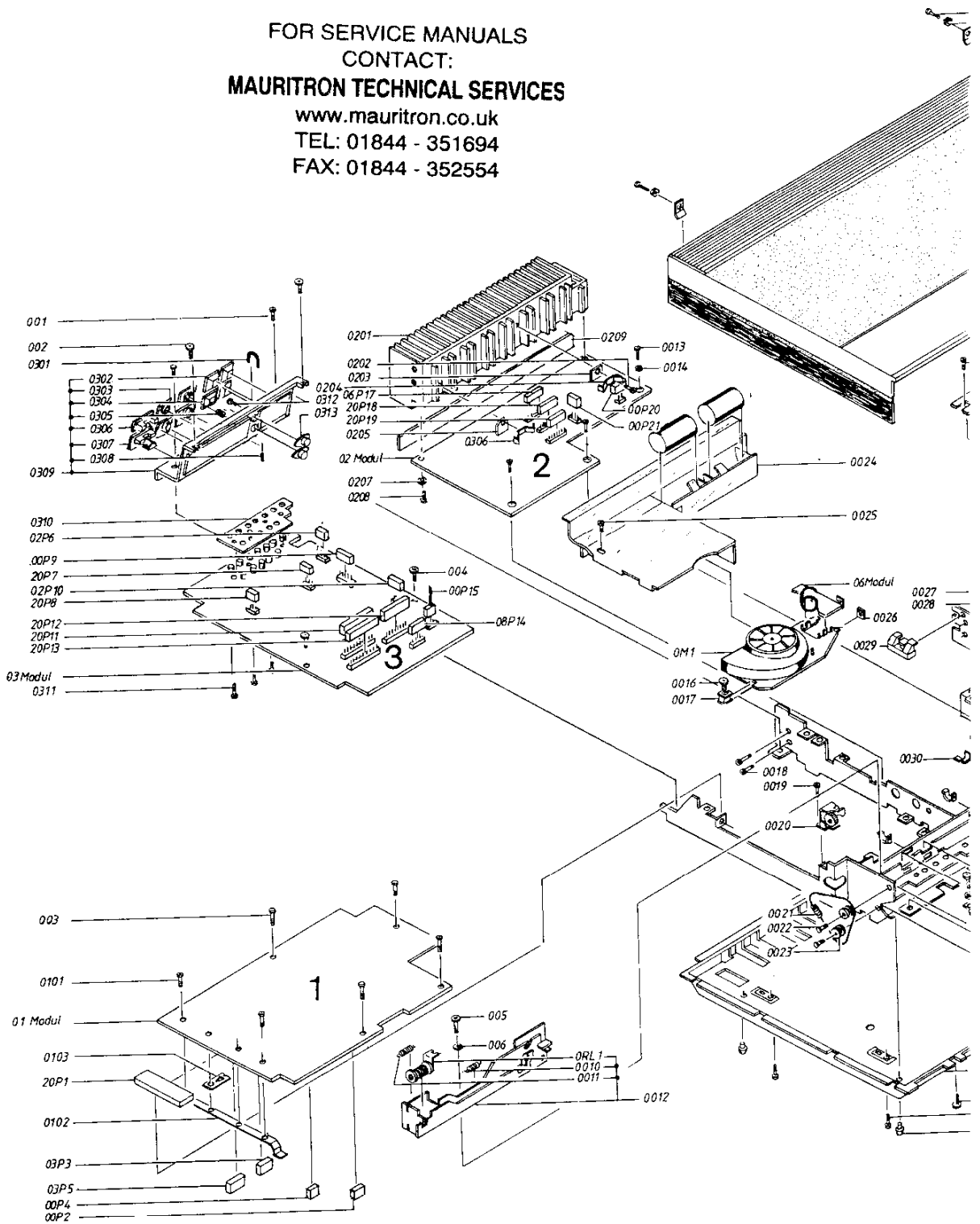

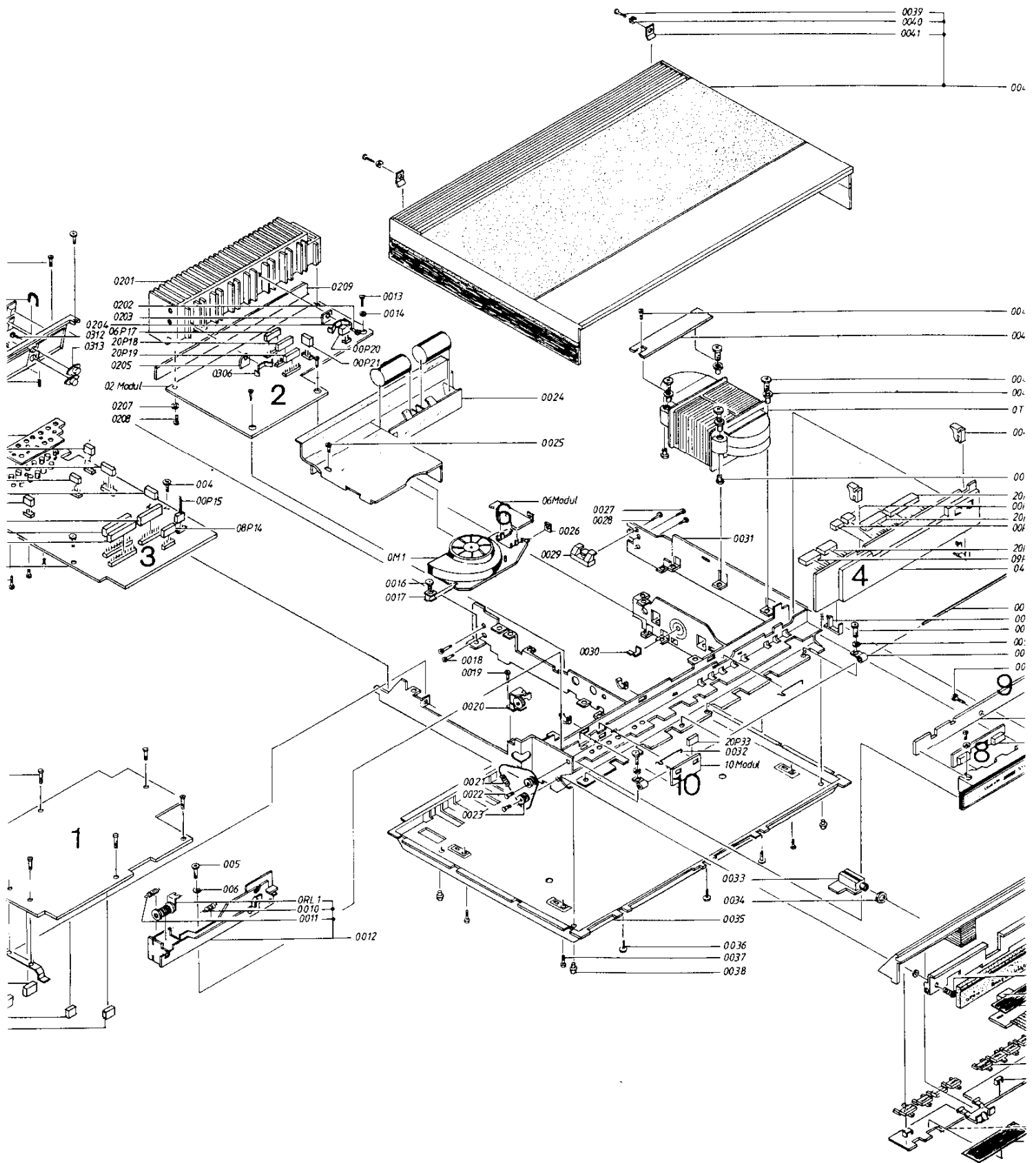

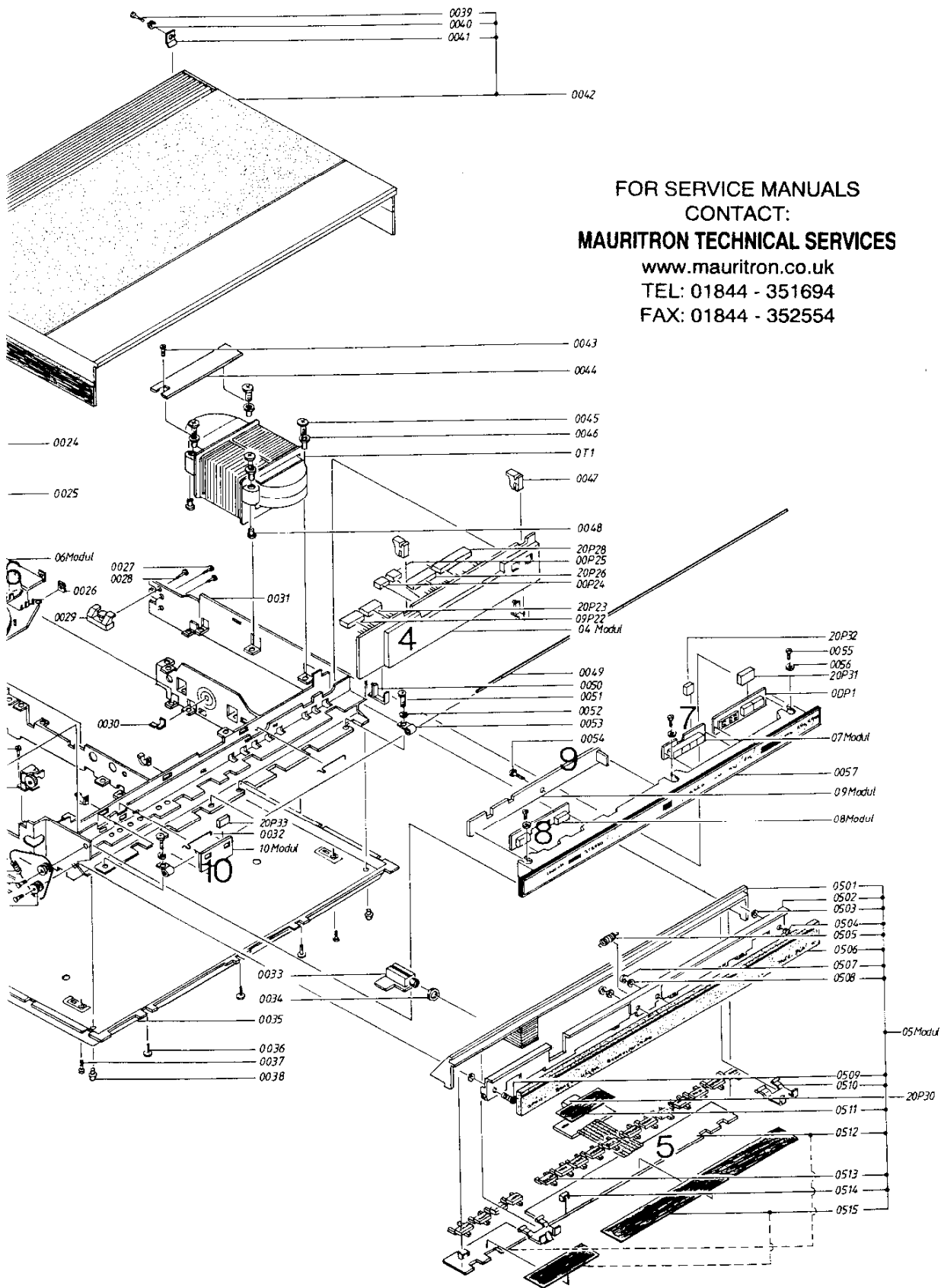

# 4-4

Master Control Panel, Type 2038

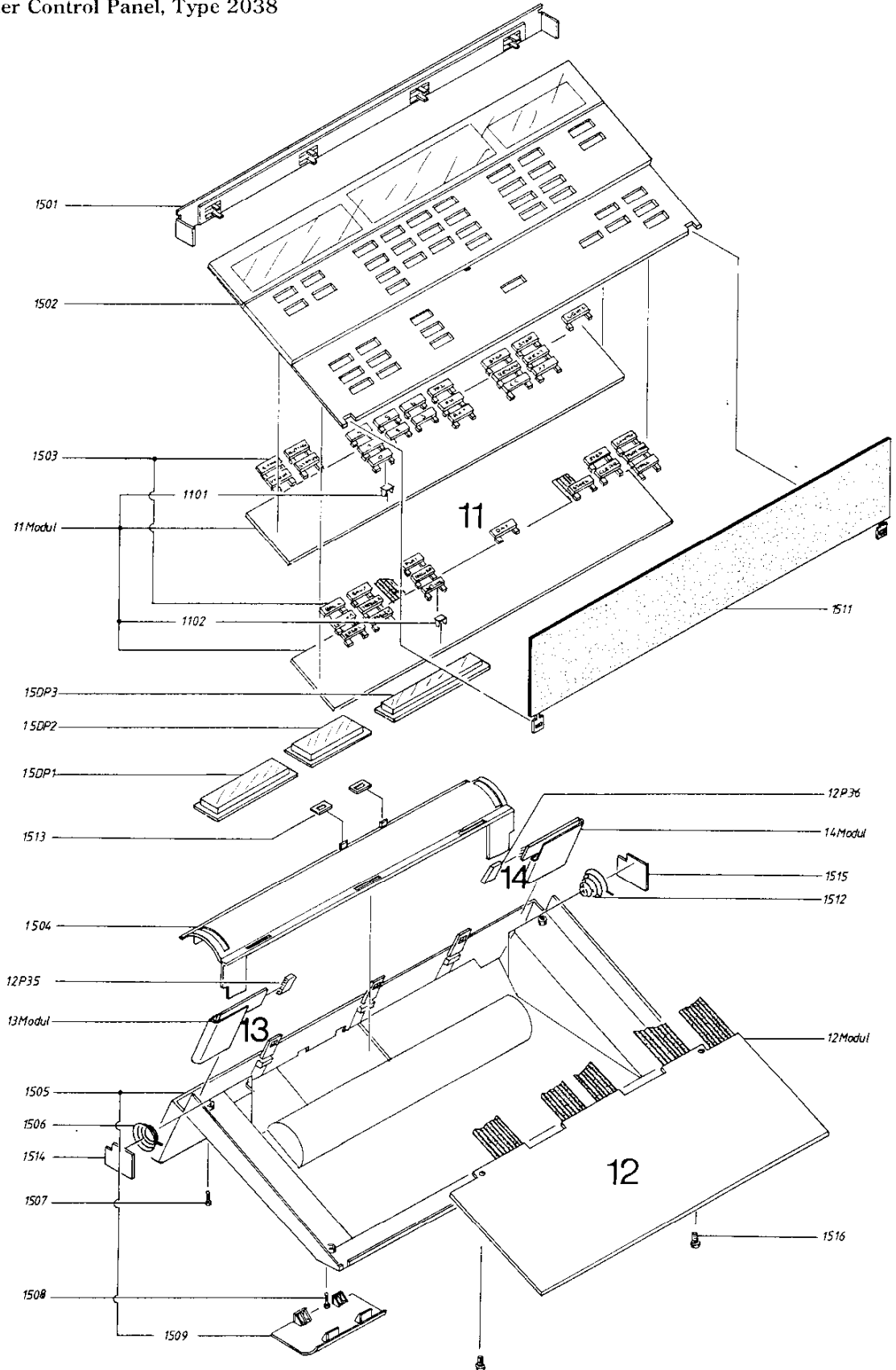

11Modul 8002580 PCB. Betjening	PCB. Keyboard
1101 7500148 Kontaktfjeder	Contact spring
1102 7500148 Kontaktfjeder	Contact spring
<hr/>	
12Modul 8002579 PCB. Microcomputer	PCB. Microcomputer
12P35 6274116 Ledning sæt med fatning	Set of wires with socket
12P36 6274117 Ledning sæt med fatning	Set of wires with socket
<hr/>	
13Modul 8002634 PCB. IR-venstre	PCB. IR-left
<hr/>	
14Modul 8002633 PCB. IR-højre	PCB. IR-right
<hr/>	
15Modul 8052164 Master Control Panel Kompl.	Master Control Panel Compl.
1501 3322103 Holder	Holder
1502 3168356 Panel	Panel
1503 2775966 Knapsæt	Set of buttons
1504 2952015 Holder	Holder
1505 3454326 Bund	Bottom
1506 2818075 Fjeder	Spring
1507 2039033 Skruer M 3 x 6	Screw M 3 x 6
1508 3010007 Stop	Stop
1509 3164460 Låg	Lid
1511 2568762 Låg	Lid
1512 2818074 Fjeder	Spring
1513 2390048 Ledningsholder	Wire holder
1514 2805000 Skærm	Screen
1515 2805000 Skærm	Screen
1516 2013080 Skruer 2,9 x 9,5	Screw 2.9 x 9.5
8700015 Batteri 1,5 V	Battery
<hr/>	
15DP1 8330100 Display indic	Display indic
15DP2 8330101 Display 3 char.	Display 3 char.
15DP3 8330102 Display 4 char.	Display 4 char.

## Beomaster Terminal, Type 2039

FOR SERVICE MANUALS  
CONTACT:  
**MAURITRON TECHNICAL SERVICES**  
[www.mauritron.co.uk](http://www.mauritron.co.uk)  
TEL: 01844 - 351694  
FAX: 01844 - 352554

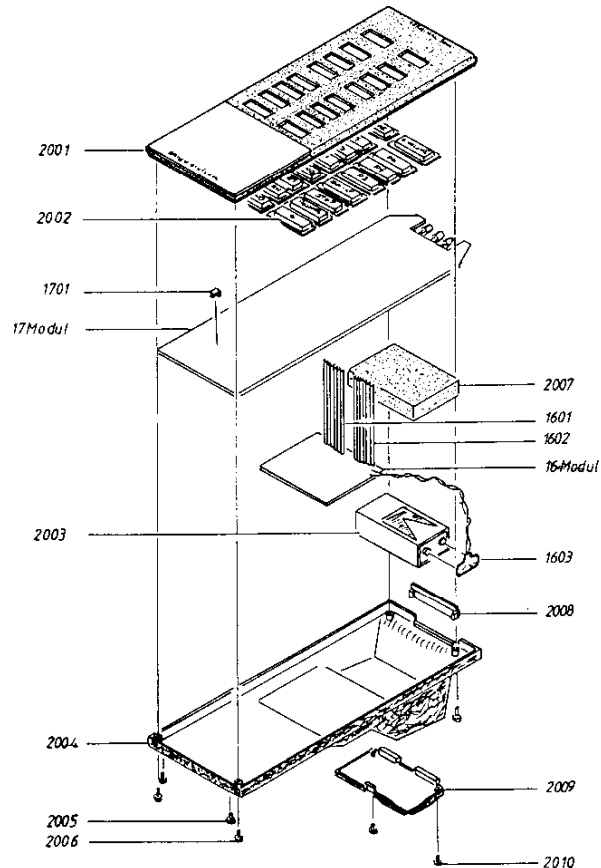

16Modul 8002200 PCB Microcomputer	PCB Microcomputer
1601 6200058 Ledningssæt, 8 leder	Set of leads, 8 leads
1602 6200058 Ledningssæt, 8 leder	Set of leads, 8 leads
1603 7229020 Batteritilslutning	Battery connection

17Modul 8002182 PCB. Betjeningsmodul	PCB, Keyboard
1701 7500148 Kontaktfjeder	Contact spring

20Modul 8052208 Beomaster terminal,	Beomaster terminal,
2001 3168379 Panel	Panel
2002 2775877 Knapsæt	Set of buttons
2003 8700000 Batteri 9 V	Battery 9 V
2004 3454343 Bund m. batteridæksel	Bottom with battery cover
2005 3010007 Stop	Stop
2006 2011023 Skrue 2.2 x 6.5	Screw 2.2 x 6.5.
2007 3917036 Skumgummi	Foam
2008 3322058 Vindue	Window
2009 3160031 Batteri dæksel	Battery cover
2010 3010007 Stop	Stop

### Moduleballage/Modulpacking

Modul no.	Designation:	Emb. no.
1	AM/FM 8002561	3391576
2	Output Amplifier and Power Supply 8002553	3391576
3	Preamplifier 8002558	3391576
4	Microcomputer 8002554	3391575
6	Fan. regulation 8002174	3391574
9	Remote Control 8002557	3391574
	Fan Complet	3391574

FOR SERVICE MANUALS  
 CONTACT:  
**MAURITRON TECHNICAL SERVICES**  
[www.mauritron.co.uk](http://www.mauritron.co.uk)  
 TEL: 01844 - 351694  
 FAX: 01844 - 352554

## ELEKTRISKE JUSTERINGER

Henvisningerne er for højre kanal. (Henvisningerne i parentes er for venstre kanal). Koordinat betegnelse er angivet efter positionsnumre.

## 5V Netdel

DC voltmeter tilsluttes modul 4 ( $\mu$ C) med - på P23 ben 4-5 og + på P23 ben 6-7.  
Med 2R15E1 justeres til  $5V \pm 0,1V$ .

## Tomgangsstrøm

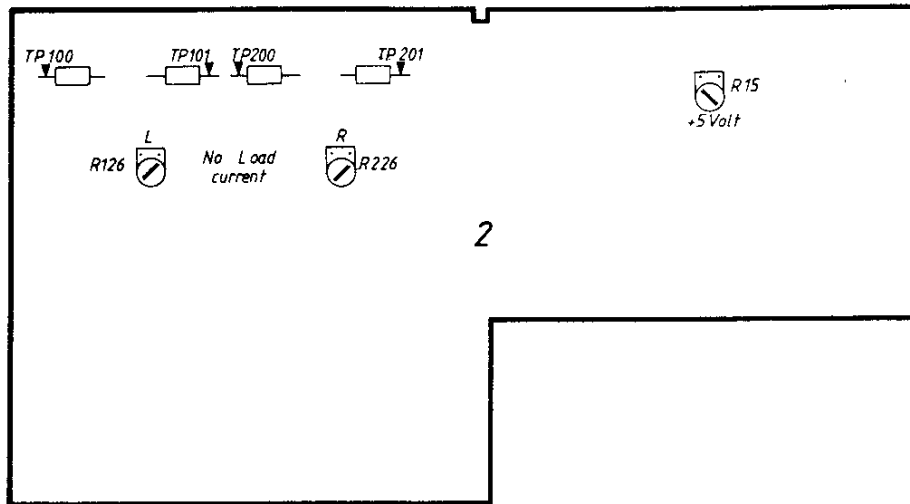

Apparatet stilles i P1-P9.

Tomgangsstrømmen justeres medens modtageren er kold og med neddrejet volumekontrol.

Højtalere må ikke være tilsluttet.

DC millivoltmeter tilsluttes mellem 2TP200B1 2TP201C2 (2TP100A1 2TP101B1).

Med 2R226A2 (2R126C2) justeres til 11 mV.

## LF

LF justeringer (volume, bas og diskant) skal foretages medens modtageren er varm (tændt i ca. 10 min.).

## Volume

Apparatet stilles i TP1. Tonegenerator tilsluttes TAPE1, og indstilles til at afgive 1 kHz 175 mV. NEUTRAL aktiveres.

Volume reguleres til max.

AC voltmeter tilsluttes 3TP200C5 (3TP100C5).

Med 3R241C6 (3R141C6) justeres indtil der måles 4,2V.

## ELECTRICAL ADJUSTMENTS

The references apply to the RH channel (the references in parenthesis apply to the LF channel). The co-ordinate denomination is indicated after the position numbers.

## 5 V Power Supply

Connect a DC voltmeter to module 4 (microcomputer) with - on pins 4-5 of P23 and + on 6-7 of P23.

Adjust with 2R15E1 until a reading of  $5V \pm 0.1V$  is obtained.

## No-load Current

Set the receiver in mode P1-P9.

Adjust the no-load current while the receiver is cold and with the volume control turned fully down.

Loudspeakers must not be connected.

Connect a DC millivoltmeter between 2TP200B1 and 2TP201C2 (2TP100A1 and 2TP101B1).

Adjust with 2R226A2 (2R126C2) until a reading of 11 mV is obtained.

## AF

Make AF adjustments (volume, bass and treble) while the receiver is warm (ON for approx. 10 minutes).

## Volume

Set the receiver in mode TP1. Connect a tone generator to TAPE 1 and set it to generate 1 kHz 175 mV.

Activate NEUTRAL.

Regulate volume to max.

Connect an AC voltmeter to 3TP200C5 (3TP100C5). Adjust with 3R241C6 (3R141C6) until a reading of 4.2 V is obtained.

FOR SERVICE MANUALS  
CONTACT:  
**MAURITRON TECHNICAL SERVICES**  
www.mauritron.co.uk  
TEL: 01844 - 351694  
FAX: 01844 - 352554

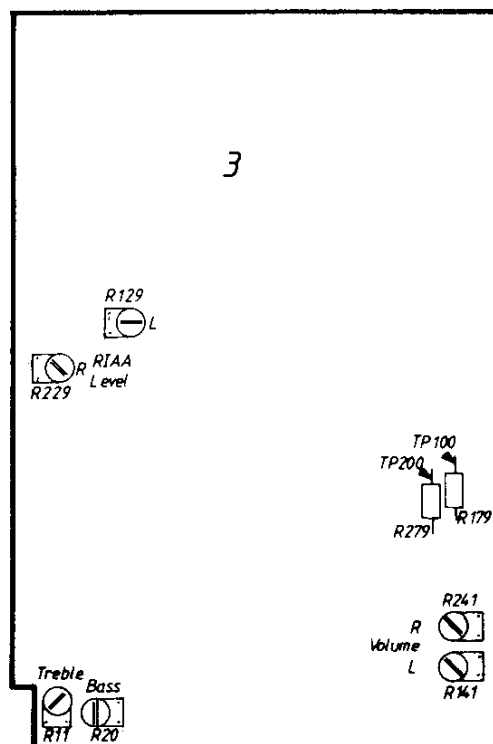

## Bas

Samme indstillinger og tilslutninger som ved volume justering, blot skal tonegeneratorens frekvens ændres til 40 Hz.  
Med 3R20A6 justeres til 4,2V i 3TP200c5.

## Diskant

Samme indstillinger og tilslutninger som ved volume justeringer blot skal tonegeneratorens frekvens ændres til 12,5 kHz.  
Med 3R11A6 justeres til 4,2V i 3TP200c5.

## RIAA

3R229A4 (3R129A4) er fra fabrikken justeret til max. output fra RIAA forstærkeren.  
Ved brug af pick-up'en med højt output niveau, kan RIAA forstærkerens output reguleres med 3R229 (3R129).

## HF

Ved tuning med MANUAL on er AFT'en stadig aktiv (LOCKED indikatoren lyser eller blinker ved signal). Ved justeringer hvor modtageren skal stå i MANUAL on må AFT'en ikke være aktiv. AFT'en kan ophæves ved nogle gentryk på RETURN eller ADVANCE, når displayet viser den ønskede frekvens.  
F.eks. MANUAL ADVANCE fra 87,5 MHz til 94 MHz. Når displayet skifter til den ønskede frekvens

## Bass

Same adjustments and connections as for the volume adjustment, with the only difference that the frequency of the tone generator is changed to 40 Hz.  
Adjust with 3R20A6 until a reading of 4.2 V is obtained in 3TP200c5.

## Treble

Same adjustments and connections as for the volume adjustment, with the only difference that the frequency of the tone generator is changed to 12.5 kHz.  
Adjust with 3R11A6 until a reading of 4.2 V is obtained in 3TP200c5.

## RIAA

3R229A4 (3R129A4) are adjusted by the factory for max. output from the RIAA amplifier.  
When using pick-up with a high output level, the RIAA amplifier output can be regulated with 3R229 (3R129).

## HF

When tuning while MANUAL in ON, the AFT will still be active (the LOCKED indicator is glowing or flashing when signals are present).  
For adjustments where the receiver must be in mode MANUAL ON, the AFT must not be active. The AFT is cancellable by activating RETURN or ADVANCE a few times when the display indicates the frequency wanted.  
For instance, MANUAL ADVANCE from 87.5 MHz to 94 MHz. When the display changes to the



gentrykkes ADVANCE derefter et tryk på RETURN.

frequency wanted, ADVANCE shall be activated a few times followed by one activation of RETURN.

AFT'en kan ligeledes ophæves ved at afbryde 1D9C3.

It is also possible to cancel the AFT by disconnecting 1D9C3.

FOR SERVICE MANUALS  
CONTACT:  
**MAURITRON TECHNICAL SERVICES**

www.mauritron.co.uk  
TEL: 01844 - 351694  
FAX: 01844 - 352554

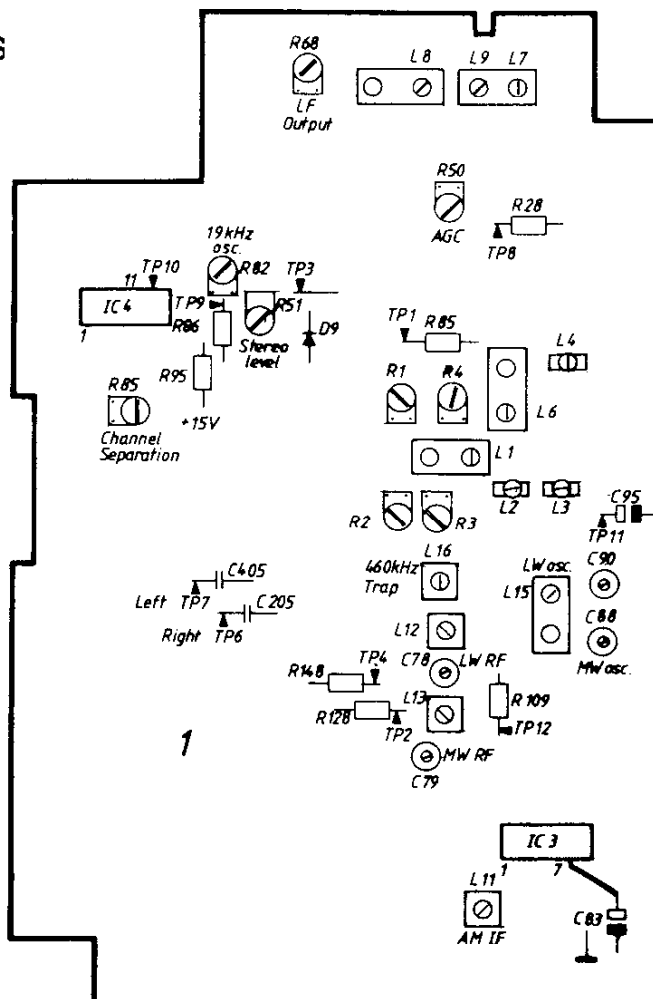

### FM OSCILLATOR OG MF

#### Oscillator 87,5 MHz

SELECT f.eks. P1 (uden signal tilført).  
Aktiver RETURN indtil displayet viser 87,5 MHz,  
LOCKED indikatoren skal være slukket (evt. støj),  
og MANUAL indikatoren skal være slukket  
(MANUAL off).

DC voltmeter tilsluttes mellem 1TP1C3 og 1TP2E3  
1L1C2 justeres til min. DC spænding målt mellem  
1TP1 og 1TP2 (spændingen må max. være 30 mV).

#### MF

Aktiver MANUAL on.  
En sweepgenerator tilsluttes antenneindgangen og  
indstilles til 87,5 MHz.  
Et oscilloskop tilsluttes 1TP3B3.

### FM OSCILLATOR AND MF

#### Oscillator 87.5 MHz

SELECT, e.g. P1 (with no signal applied).  
Activate RETURN until the display indicates 87.5  
MHz, the LOCKED indicator must be off (noise  
possible), and the MANUAL indicator must be off  
(MANUAL off).

Connect a voltmeter between 1TP1C3 and 1TP2E3.  
Adjust 1L1C2 until min. DC voltage reading is  
obtained between 1TP1 and 1TP2 (max. voltage  
allowed is 30 mV).

#### IF

Activate MANUAL on.  
Connect a sweep generator to the aerial input and  
set it at 87.5 MHz.  
Connect an oscilloscope to 1TP3B3.

Med 1L2D2, 1L3D1, 1L4C1, 1L6C2 justeres til maksimum og symmetrisk MF kurve. (Gentag evt. proceduren).

### Oscillator 108 MHz

Aktiver MANUAL off (uden signal tilført).  
Aktiver ADVANCE indtil displayet viser 108 MHz.  
Aktiver MANUAL on.  
DC voltmeter tilsluttes 1TP2E3.  
1R1C3 justeres til 19,6V  $\pm$ 200 millivolt.

### MF

Sweepgenerator tilsluttes antenneindgangen og indstilles til 108 MHz.  
Oscilloscop tilsluttes 1TP3B3.  
Med 1R2D3, 1R3D2, 1R4C4 justeres til maksimum og symmetrisk MF kurve.

### AGC

En målesender tilsluttes antenneindgangen, den indstilles på f.eks. 94 MHz og til at afgive 1 mV EMF,  $\Delta \pm 75$  kHz.  
Aktiver MANUAL on.  
Modtageren indstilles på samme frekvens som målesenderen.  
Oscilloscop tilsluttes 1TP3B3.  
På modtageren eller målesenderen finindstilles til min. 2. harmonisk forvrængning af signalet som vist på kurven.



Adjust with 1L2D2, 1L3D1, 1L4C1, 1L6C2 until maximum and symmetrical IF-curve is obtained. (Repeat the procedure, if necessary).

### Oscillator 108 MHz

Activate MANUAL off (with no signal applied).  
Activate ADVANCE until the display indicates 108 MHz.  
Activate MANUAL on.  
Connect a DC voltmeter to 1TP2E3.  
Adjust 1R1C3 to 19.6 V  $\pm$ 200 mV.

### IF

Connect a sweep generator to the aerial input and set it at 108 MHz.  
Connect an oscilloscope to 1TP3B3.  
Adjust with 1R2D3, 1R3D2, 1R4C4 until maximum and symmetrical IF-curve.

### AGC

Connect a signal generator to the aerial input and set it at, e.g. 94 MHz and to yield 1 mV EMF,  $\pm 75$  kHz.  
Activate MANUAL on.  
Set the receiver to the same frequency as the signal generator.  
Connect an oscilloscope to 1TP3B3.  
Make fine adjustments on the receiver or the generator to min. 2nd harmonic of the signal, as shown on the curve.



DC voltmeter tilsluttes 1TP8B2.  
Med 1R50B2 justeres indtil der måles mellem 3 og 4 volt i 1TP8.

### Detektor

For at der kan foretages en korrekt justering af detektoren, skal der bl.a. anvendes et forvrængningsmeter som beskrevet i punkt 1.  
Hvis et forvrængningsmeter ikke er tilgængeligt, kan der foretages en tilnærmet justering som beskrevet i punkt 2.

1. Aktiver MANUAL on.  
Modtageren indstilles på f.eks. 94 MHz.  
En kombineret målesender og sweepgenerator tilsluttes antenneindgangen, og indstilles til at afgive 1 mV EMF,  $\Delta \pm 75$  kHz.  
Målesenderens frekvens indstilles til 94 MHz, og til min. 2. harmonisk af signalet (se skitse).

Connect a DC voltmeter to 1TP8B2.  
Adjust with 1R50B2 until a reading between 3 and 4 V is obtained in 1TP8.

### Detector

To enable a correct adjustment of the detector, a distortion meter is needed, among other instruments, as mentioned in point 1.  
If a distortion meter is not available, an approximated adjustment can be made, as described in point 2.

1. Activate MANUAL on.  
Set the receiver at, e.g. 94 MHz.  
Connect a combination signal generator and a sweep generator to the aerial input and set it to yield 1 mV EMF,  $\pm 75$  kHz.  
Set the signal generator frequency at 94 MHz and for min. 2nd harmonic of the signal (see diagram).

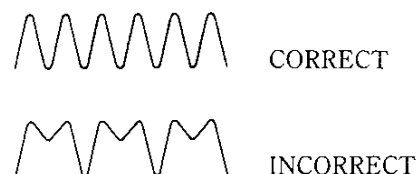
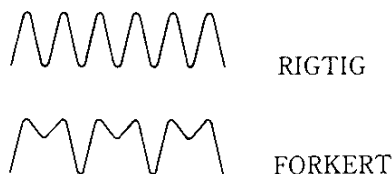

Et forvrængningsmeter tilsluttes højttalerudgangen.  
 Et DC voltmeter tilsluttes 1TP4E3.  
 Med 1L7A2 justeres, indtil der måles minimum forvrængning.  
 Derefter justeres med 1L9A2, indtil der måles 0V i 1TP4.  
 Gentag begge justeringer, indtil de er i orden.

Connect a distortion meter to the loudspeaker output.  
 Connect a DC voltmeter to 1TP4E3.  
 Adjust with 1L7A2 until min. distortion is obtained.  
 Then adjust with 1L9A2 until a reading of 0 V is obtained in 1TP4.  
 Repeat both adjustments until they are OK.

2. Justeringen foretages ved hjælp af »S-kurven«, men der vil være usikkerhed for, hvorvidt modtageren overholder sine forvrængningsdata. Aktiver MANUAL on. Modtageren indstilles på f.eks. 94 MHz. En kombineret målesender og sweepgenerator tilsluttes antenneindgangene, og indstilles til at afgive 1 mV EMF,  $\Delta\pm 75$  kHz. Målesenderens frekvens indstilles til 94 MHz, og til min. 2. harmonisk af signalet (se skitse).

2. Make the adjustment by means of the »S-curve«, but it will be uncertain whether the receiver adheres to its distortion data. Activate MANUAL on. Set the receiver at, e.g. 94 MHz. Connect a combination signal generator and a sweep generator to the aerial input and set it to yield 1 mV EMF,  $\Delta\pm 75$  kHz. Set the signal generator frequency at 94 MHz and for min. 2nd harmonic of the signal (see diagram).

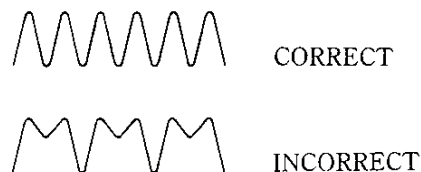
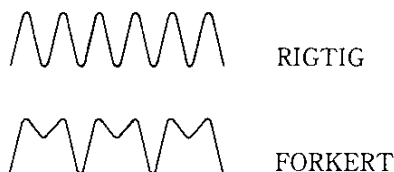

Generatoren indstilles til sweep.  
 Et oscilloskop tilsluttes 1TP7D4 og et DC voltmeter tilsluttes 1TP4E3.  
 Med 1L7A2 og 1L9A2 justeres til maksimum og symmetrisk S kurve.  
 Derefter justeres 1L9 indtil der måles 0V i 1TP4.

Set the generator to sweep.  
 Connect an oscilloscope to 1TP7D4 and connect a DC voltmeter to 1TP4E3.  
 Adjust with 1L7A2 and 1L9A2 until maximum and symmetrical S-curve has been obtained. Then adjust with 1L9 until a reading of 0 V is obtained in 1TP4.

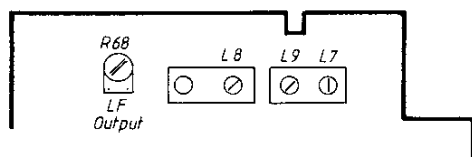

### FM-LF output

En målesender tilsluttes antenneindgangen, der indstilles på f.eks. 94 MHz og til at afgive 1 mV EMF,  $\Delta\pm 75$  kHz.  
 Aktiver MANUAL on.

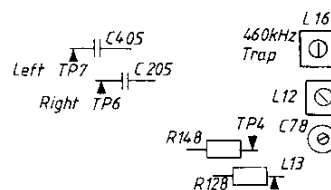

### FM-AF Output

Connect a signal generator to the aerial input and set it at e.g. 94 MHz and to yield 1 mV EMF,  $\Delta\pm 75$  kHz.  
 Activate MANUAL on.

Modtageren indstilles på samme frekvens som målesenderen og stilling MONO.  
AC voltmeter tilsluttes 1TP7D4.  
1R68A3 justeres indtil der måles 650-750 millivolt i 1TP7.

### Åbning af stereodekoder

En målesender tilsluttes antenneindgangen, den indstilles på f.eks. 94 MHz og til at afgive 25µV EMF,  $\Delta\pm 75$  kHz.  
Aktiver MANUAL on.  
Modtageren indstilles på samme frekvens som målesenderen.

Set the receiver to the same frequency as the signal generator and in mode MONO.  
Connect an AC voltmeter to 1TP7D4.  
Adjust 1R68A3 until a reading of 650-750 mV is obtained in TP7.

### Opening of Stereo Decoder

Connect a signal generator to the aerial input and set it at e.g. 94 MHz and to yield 25 µV  $\Delta\pm 75$  kHz.  
Activate MANUAL on.  
Tune the receiver to the same frequency as that of the signal generator.

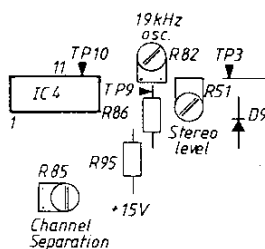

FOR SERVICE MANUALS  
CONTACT:  
**MAURITRON TECHNICAL SERVICES**  
www.mauritron.co.uk  
TEL: 01844 - 351694  
FAX: 01844 - 352554

Et DC voltmeter tilsluttes 1TP9B4.  
Med potentiometeret 1R51B3 justeres, indtil der måles 0,6V.

### Stereodekoder

#### Oscillator

For at denne justering kan foretages korrekt, skal der anvendes en frekvenstæller eller Bang & Olufsens voltmeter RV11 og frekvens probe. PF5 som beskrevet i punkt 1. Hvis omtalte instrumenter ikke er tilgængeligt, kan der foretages en tilnærmet justering som beskrevet i punkt 2.

- Lad en 220 kohms modstand fra basis af 1TR7 (1TP9B4) til +15VC4.  
Indstil modtageren på en mono station.  
En frekvenstæller (eller RV11/PF5) tilsluttes 1TP10B4.  
Med potentiometeret 1R82B4 justeres, indtil der måles 19 kHz  $\pm 50$  Hz.  
Efter endt justering fjernes den påloddede modstand.
- Lod en 220 kohms modstand fra basis af 1TR7 (1TP9B4) til +15VC4.  
Indstil modtageren på en stereo station.  
Potentiometeret 1R82B4 drejes imod uret (set fra komponentsiden), indtil stereovirkningen lige netop ophører. Derefter drejes 1R82 med uret, indtil stereovirkningen lige netop ophører. Indstil nu 1R82 midt imellem de to stillinger, og der er opnået en tilnærmelsesvis korrekt justering.

Connect a DC voltmeter to 1TP9B4.  
Adjust with the potentiometer 1R51B3 until a reading of 0.6 V is obtained.

### Stereo Decoder

#### Oscillator

In order to make this adjustment correctly a frequency counter or Bang & Olufsen's voltmeter RV11 and frequency probe FP5 must be used, as described in point 1. If these instruments are not available, an approximated adjustment can be made, as described in point 2.

- Solder a 220 kohm resistor from the base of 1TR7 (1TP9B4) to +15 VC4.  
Tune the receiver to a mono transmitting station.  
Connect a frequency counter (or RV11/PF5) to 1TP10B4.  
Adjust with the potentiometer 1R82B4 until a reading of 19 kHz  $\pm 50$  Hz is obtained.  
Remove the soldered-on resistor when the adjustment is completed.
- Solder a 220 kohm resistor from the base of 1TR7 (1TP9B4) to +15 VC4.  
Tune the receiver to a stereo transmitting station.  
Turn the potentiometer 1R82B4 anti-clockwise (as seen from the component side) until the stereo effect just ceases. Now turn 1R82 clockwise until the stereo effect just ceases. Next, adjust 1R82 centrally between the two positions, and an approximately correct adjustment has been obtained.

Efter endt justering fjernes den påloddede modstand.

Remove the soldered-on resistor when the adjustment is completed.

## Kanalseparation

## Channel Separation

FOR SERVICE MANUALS  
CONTACT:  
**MAURITRON TECHNICAL SERVICES**  
www.mauritron.co.uk  
TEL: 01844 - 351694  
FAX: 01844 - 352554

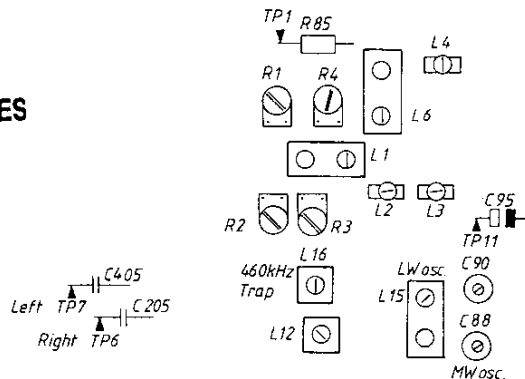

En stereokoder (Encoder) tilsluttes antenneindgangen.

Connect a stereo encoder to the aerial input.

Wattmeter tilsluttes højttalerudgangen eller AC voltmeter tilsluttes 1TP6D4 (1TP7D4).

Connect a wattmeter to the loudspeaker output or an AC voltmeter to 1TP6D4 (1TP7D4).

Med potentiometeret 1R85C5 justeres, indtil der opnås minimum signal i moduleret kanal.

Adjust with the potentiometer 1R85C5 until minimum signal is obtained in the unmodulated channel.

### Locked FM

### Locked FM

En målesender tilsluttes antenneindgangen, den indstilles på f.eks. 94 MHz og til at afgive 10µV EMF,  $\Delta\pm 75$  kHz.

Connect a signal generator to the aerial input and set it at e.g. 94 MHz and to yield 10 µV EMF,  $\Delta\pm 75$  kHz.

Modtageren indstilles på samme frekvens som målesenderen og sættes i stilling MANUAL off. Potentiometeret 10R1 drejes helt mod venstre, og derefter mod højre indtil LOCKED indikatoren netop tænder.

Tune the receiver to the same frequency as the signal generator and set it in mode MANUAL off. Turn the potentiometer 10R1 all the way anti-clockwise and then clockwise until the LOCKED indicator just starts glowing.

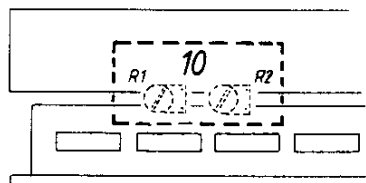

NB: 10R1 er tilgængelig fra fronten af apparatet og kan derfor let omjusteres, hvis lokale modtagerforhold eller kundeønsker nødvendiggør dette.

**NOTE:** 10R1 is accessible from the front of the receiver and, consequently, it is easily re-adjustable in case local reception conditions or customer wishes should necessitate that.

## AM

NB! Der må ikke justeres i MW oscillatorspolen 1L14.

## AM

NOTE! Do not adjust in the MW oscillator coil 1L14.

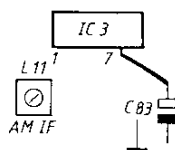

For at undgå indvirkning fra AGC under AM justeringer, anbefales det at kortslutte ben 7 på IC3 til stel.

To avoid interference from AGC during AM adjustment it is recommended to short-circuit pin 7 on IC3 to chassis.

## MW oscillator

## MW oscillator

**FOR SERVICE MANUALS  
CONTACT:  
MAURITRON TECHNICAL SERVICES**  
www.mauritron.co.uk  
TEL: 01844 - 351694  
FAX: 01844 - 352554

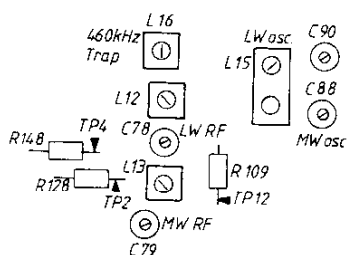

Step til MW (uden signal tilført).  
Aktiver MANUAL off.  
Aktiver ADVANCE indtil displayet viser 1610 kHz.  
LOCKED indikatoren skal være slukket.  
DC voltmeter tilsluttes 1TP2E3.  
1C88E8 justeres til 25V ±300 mV.

Step to MW (with no signal applied).  
Activate MANUAL off.  
Activate ADVANCE until the display indicates 1610 kHz.  
The LOCKED indicator must be off.  
Connect a DC voltmeter to 1TP2E3.  
Adjust 1C88E3 until a reading of 25 V ±300 mV is obtained.

Aktiver RETURN indtil displayet viser 520 kHz.  
Spændingen i 1TP2 aflæses og noteres (spændingen skal ligge mellem 1,5 V og 2,5V).

Activate RETURN until the display indicates 520 kHz.  
Take a reading and make a note of the voltage in 1TP2 (the voltage should be somewhere between 1.5 V and 2.5 V).

## LW oscillator

Step til LW (uden signal tilført).  
Aktiver MANUAL off.  
Aktiver RETURN indtil displayet viser 150 kHz.  
1L15D1 justeres indtil spændingen i 1TP2, er den samme som spændingen noteret ved MW oscillator justeringen.

## LW oscillator

Step to LW (with no signal applied).  
Activate MANUAL off.  
Activate RETURN until the display indicates 150 kHz.  
Adjust 1L15D1 until the voltage in 1TP2 is identical with the voltage noted down during the MW oscillator adjustment.

Aktiver ADVANCE indtil displayet viser 350 kHz.  
1C90D1 justeres til 25V ±300 mV.

Activate ADVANCE until the display indicates 350 kHz.  
Adjust 1C90D1 until a reading of 25 V ±300 mV is obtained.

Aktiver RETURN indtil displayet viser 150 kHz.  
Kontroller at spændingen i 1TP2 er den samme som den noterede spænding. Er dette ikke tilfældet, gentages proceduren til den er korrekt.

Activate RETURN until the display indicates 150 kHz.  
Check that the voltage in 1TP2 is identical with the voltage noted down. If this is not the case, repeat the procedure until it is correct.

AM MF og AFT

AM IF and AFT

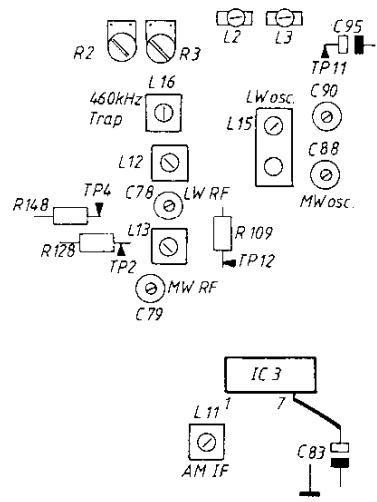

En sweepgenerator tilsluttes antenneindgangen, og indstilles til centerfrekvens 460 kHz  $\Delta$ 10 kHz. 1TP12E2 (basis på 1TR22) kortsluttes til stel. 1L16D2 forstemmes ved at dreje kernen ud. Step til MW. Aktiver MANUAL on. Aktiver ADVANCE indtil displayet viser 1500 kHz. Oscilloscop tilsluttes 1TP11D1. Med 1L11F2 justeres til maksimum og symmetrisk MF kurve.

Connect a sweep generator to the aerial input and adjust it to centre frequency 460 kHz  $\Delta$ 10 kHz. Short-circuit 1TP12E2 (base on 1TR22) to chassis. Detune 1L16D2 by turning out the core. Step to MW. Activate MANUAL on. Activate ADVANCE until the display indicates 1500 kHz. Connect an oscilloscope to 1TP11D1. Adjust with 1L11F2 to maximum and symmetrical IF-curve.

AFT

AFT

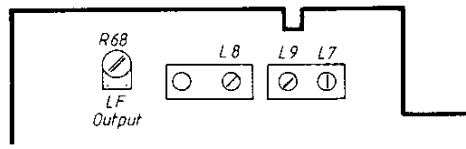

Sweepgeneratorens output niveau stilles til ca. 1 mV, og generatorens frekvens finreguleres således at den står nøjagtigt på modtagerens mellemfrekvens. DC voltmeter tilsluttes 1TP4E3. Med 1L8A2 justeres til 0V i 1TP4. 1L16D2 justeres til minimum MF kurve. Kortslutningen i 1TP12 fjernes.

Set the sweep generator output level at approx. 1 mV and fine-adjust the frequency of the generator until it is exactly at the intermediate frequency of the receiver. Connect a DC voltmeter to 1TP4E3. Adjust with 1L8A2 until a reading of 0 V is obtained in 1TP4. Adjust 1L16D2 until minimum IF-curve is obtained. Remove the short-circuit in 1TP12.

#### Antennekredse MW

En målesender tilsluttes antenneindgangen, og indstilles til 1500 kHz, modulation 30% 400 Hz eller 1 kHz.

#### Aerial circuits MW

Connect a signal generator to the aerial input and set it at 1500 kHz, modulation 30% 400 Hz or 1 kHz.

Wattmeter tilsluttes højttalerudgangen eller AC voltmeter tilsluttes 1TP6D4 (1TP7D4). Aktiver MANUAL on.

Connect a wattmeter to the loudspeaker output or an AC voltmeter to 1TP6D4 (1TP7D4). Activate MANUAL on.

FOR SERVICE MANUALS

CONTACT:

**MAURITRON TECHNICAL SERVICES**

www.mauritron.co.uk

TEL: 01844 - 351694

FAX: 01844 - 352554

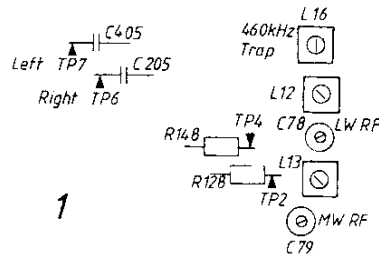

1

Modtageren indstilles til displayet viser 1500 kHz.  
 1C79F2 justeres til max. output.  
 Målesender og modtager indstilles til 575 kHz.  
 1L13E2 justeres til max. output.  
 Proceduren gentages, indtil den er i orden.

Adjust the receiver until the display indicates 1500 kHz.  
 Adjust 1C79F2 until max. output is obtained.  
 Set signal generator and receiver at 575 kHz.  
 Adjust 1L13E2 until max. output is obtained.  
 Repeat the procedure until everything is OK.

### Antennekredse LW

Målesender og modtager indstilles 330 kHz.  
 1C78E2 justeres til max. output.  
 Målesender og modtager indstilles til 160 kHz.  
 1L12F2 justeres til max. output.  
 Proceduren gentages, indtil den er i orden.

### Aerial Circuits MW

Set signal generator and receiver at 330 kHz.  
 Adjust 1C78E2 until max. output is obtained.  
 Set signal generator and receiver at 160 kHz. Adjust  
 1L12F2 until max. output is obtained.  
 Repeat the procedure until everything is OK.

### Locked AM

En målesender tilsluttes antenneindgangen, og indstilles til 575 kHz, modulation 30% 400 Hz eller 1 kHz, 50  $\mu$ V.  
 Modtageren indstilles på 575 kHz og i stilling MANUAL off.  
 Potentiometeret 10R2 drejes helt mod venstre, og derefter mod højre indtil LOCKED indikatoren netop tænder.

### Locked AM

Connect a signal generator to the aerial input and set it at 575 kHz, modulation 30% 400 Hz or 1 kHz, 50  $\mu$ V.  
 Set the receiver at 575 kHz and in mode MANUAL off.  
 Turn the potentiometer 10R2 all the way to the left and then to the right until the LOCKED indicator just starts glowing.

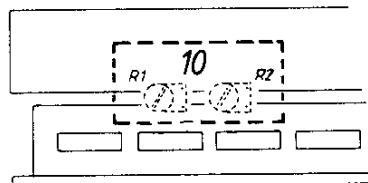

NB: 10R2 er tilgængelig fra fronten af apparatet og kan derfor let omjusteres, hvis lokale modtagerforhold eller kundeønsker nødvendiggør dette.

NOTE! 10R2 is accessible from the front of the receiver and, consequently, is easily re-adjustable if local receiving conditions or customer wishes should so necessitate.



IR modtager  
Beomaster

IR Receiver  
Beomaster



Oscilloscop tilsluttes emitter på 9IC2.  
MASTER CONTROL PANELET placeres indirekte mod sensor.  
Aktiver volume ned på MASTER CONTROL PANELET.  
9L1 justeres til max.

Connect an oscilloscope to the emitter of 9IC2.  
Place the MASTER CONTROL PANEL indirectly towards the sensor.  
Activate Volume Down on the MASTER CONTROL PANEL.  
Adjust 9L1 to max.

MASTER CONTROL PANEL

MASTER CONTROL PANEL

Forsyningsspænding

Supply Voltage

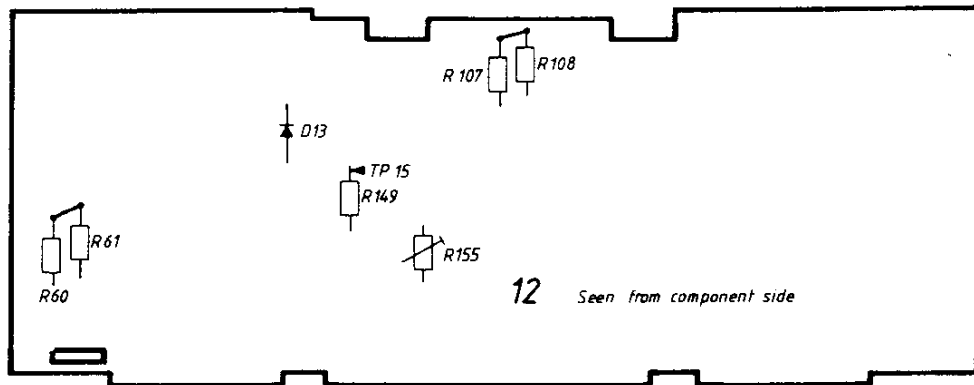

12TP15 kortsluttes til stel.  
Med 12R155 justeres til der måles  $4,75 \pm 0,1$  V på kollektoren af 12TR52.

Short-circuit 12TP15 to chassis.  
Adjust with 12R155 until a reading of  $4,75 \pm 0,1$  V on the collector of 12TR52 is obtained.

Remote modtagere

Remote transceivers

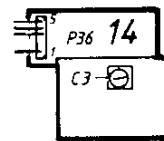
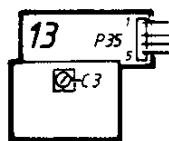

Ved justering af remote transceiverne, modul 13 og 14, benyttes den ene transceiver til at sende til den anden.  
Den transceiver, som skal justeres, skal afmonteres og placeres ca. 40 cm foran control panelet for at undgå overstyring.  
Justeringen af de to transceivere er ens, og beskrivelsen omfatter derfor kun modul 13.  
Der loddes en modstand på 47 kohm fra P35-1 til P35-4.

When adjusting the remote transceivers, modules 13 and 14, use one transceiver for transmitting to the other.  
Dismount the transceiver to be adjusted and place it approx. 40 cm in front of the control panel in order to avoid overriding.  
Since the adjustment of the two transceivers is identical, this description only deals with module 13.  
Solder a resistor of 47 kohm from P35-1 to P35-4.

Modul 13 tilføres spænding ved at lodde en ledning fra P35-1 til + forsyningen på control panelet eller anden ekstern strømforsyning (4-10V). Stelledning loddes på P35-3.  
Oscilloscop tilsluttes P35-4.

Apply to module 13 a voltage by soldering a lead from P35-1 to the +supply on the control panel or another external power supply (4-10 V). Solder chassis lead on to P35-3.  
Connect an oscilloscope to P35-4.

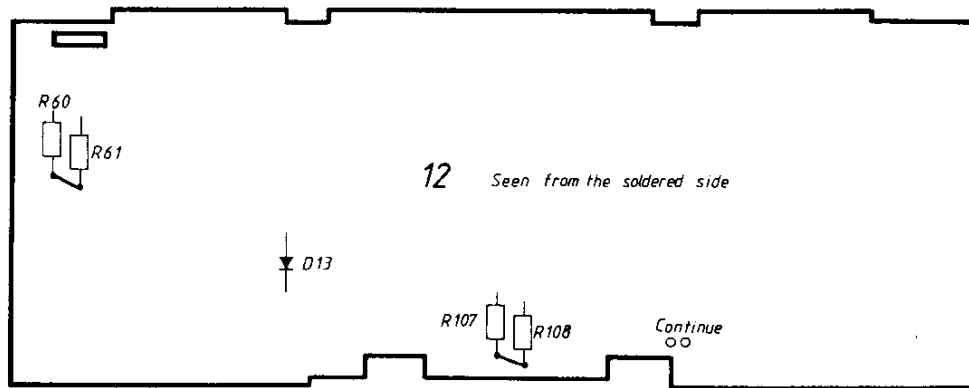

Printpunkterne mærket CONTINUE kortsluttes (på komponentsiden er CONTINUE punkterne = fællespunktet for 12R107 og 12R108 → katoden af 12D13. 13C3 justeres til maksimum.

Short-circuit the PCB points marked CONTINUE (on the component side the CONTINUE points = the node of 12R107 and 12R108 → the cathode of 12D13. Adjust 13C3 to maximum.

FOR SERVICE MANUALS  
CONTACT:  
**MAURITRON TECHNICAL SERVICES**  
www.mauritron.co.uk  
TEL: 01844 - 351694  
FAX: 01844 - 352554

## TECHNICAL SPECIFICATIONS

## Amplifier section

Power output RMS DIN/IEC	2 x 60 watts/8 ohms
Power output music	2 x 85 watts/8 ohms
Harmonic distortion DIN/IEC	<0.02%
Power output 20-20,000 Hz IHF	2 x 55 watts/8 ohms
Total harmonic distortion IHF	<0.09%
Following measurements:	IHF A-202
Dynamic headroom	1 dB/8 ohms, 2 dB/4 ohms
IHF intermodulation	<0.15%

## Response vs frequency

Phono	20-20,000 Hz $\pm$ 1.5 dB
Tape	20-20,000 Hz $\pm$ 1.5 dB
Wideband damping factor	100

## Input sensitivity/impedance

Phono	0.3 mV-0.6 mV/47 kohms
Tape	23 mV/220 kohms
Line	450 mV/10 kohms

## Overload level:

Phono	55 mV-110 mV
Tape	6 V

## Signal-to-noise ratio

Phono A-weighted	>74 dB
Tape A-weighted	>76 dB
Channel separation	45 dB

## Output

Tape	400 mV/1 kohms
Line	450 mV/1 kohms
Headphones	Max. 10 V/470 ohms
Bass control at 40 Hz	$\pm$ 12 dB
Treble control at 12.500 Hz	$\pm$ 11 dB

## FM tuner section

Standard for measurements (RF)	IHF T-200
FM range	87.5-108 MHz
FM aerial impedance	75 and 240 ohms
Usable sensitivity mono	15 dBf-1.5 $\mu$ V/75 ohms
Usable sensitivity stereo	17 dBf-2 $\mu$ V/75 ohms
50 dB quieting sensitivity mono	21 dBf-3.2 $\mu$ V/75 ohms
50 dB quieting sensitivity stereo	42 dBf-35 $\mu$ V/75 ohms

Signal-to-noise ratio at 65 dBf mono	70 dB
Signal-to-noise ratio at 65 dBf stereo	67 dB

Frequency response	20-15,000 Hz $\pm$ 1.5 dB
Distortion at 65 dBf mono	0.3%
Distortion at 65 dBf stereo	0.35%
Intermodulation distortion mono	0.05%
Intermodulation distortion stereo	0.25%

Capture ratio	1.8 dB
Adjacent channel selectivity	6 dB
Alternate channel selectivity	56 dB
Spurious response	96 dB
Image response ratio	75 dB
iF response ratio	110 dB
AM suppression	55 dB

Stereo channel separation	
100-10,000 Hz	40 dB
Subcarrier product rejection	64 dB

## AM tuner section

LW range	150-350 kHz
MW range	520-1610 kHz
LW sensitivity 20 dB S/N ratio	140 $\mu$ V
MW sensitivity 20 dB S/N ratio	100 $\mu$ V

FOR SERVICE MANUALS  
CONTACT:  
**MAURITRON TECHNICAL SERVICES**  
www.mauritron.co.uk  
TEL: 01844 - 351694  
FAX: 01844 - 352554

Other data

Power supply	220 volts
Power frequency	50-60 Hz
Power consumption	15-225 watts
Dimensions W x H x D	42 x 7.5 x 32.5 cm
Weight	8.5 kg

**Subject to change without notice**

FOR SERVICE MANUALS  
CONTACT:  
**MAURITRON TECHNICAL SERVICES**  
[www.mauritron.co.uk](http://www.mauritron.co.uk)  
TEL: 01844 - 351694  
FAX: 01844 - 352554

**ADSKILLELSE**  
Kabinet

**DISMANTLING**  
Cabinet

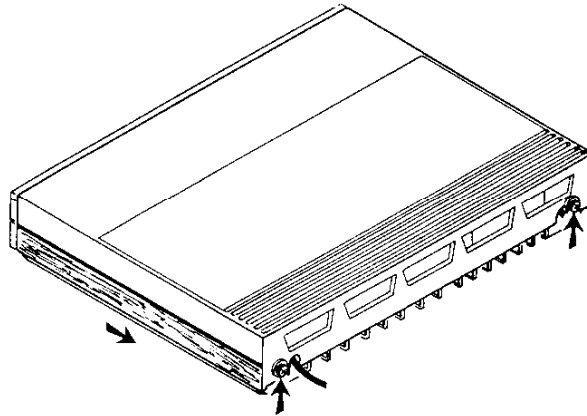

De to skruer i bagkanten løsnes og løftes op. Kabinettet presses ca. 1 cm bagud og kan nu løftes af.

Loosen the two screws at the rear edge and press them upwards while simultaneously pushing the cabinet approx. 1 cm rearwards. It can now be removed.

**Bund**

**Bottom**

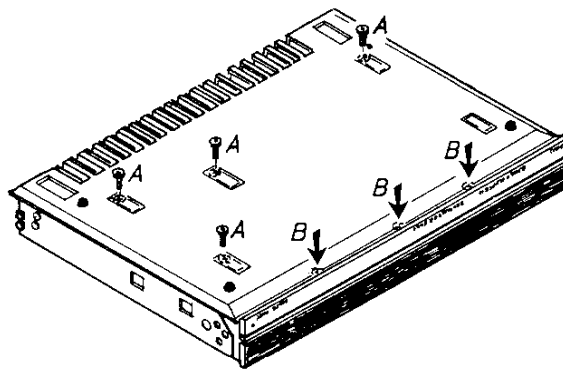

De fire skruer (A) fjernes og de 3 skruer (B) løsnes. Bunden kan nu løftes af.

Remove the four screws (A) and loosen the 3 screws (B). The bottom can now be removed.

**Bemærk ved kabinetmontage**

For at opnå korrekt montering af kabinettet efter at bundpladen har været afmonteret, iagttages følgende monteringsvejledning.

Top (pos. nr. 0042) og bund (pos. nr. 0035) spændes sammen med skruerne (A og B). Apparatet stilles på højkant på en jævn bordplade med fronten nedad. (Pas på ridser). (Bundskruerne skal være løsnet). Når toppens kant rører bordpladen tilspændes bundskruerne, hvorefter kabinettet sidder korrekt placeret.

**Note when assembling cabinet**

In order to obtain correct mounting of the cabinet after dismantling the bottom plate please note the following mounting instruction:

Assemble top (pos. no. 0042) and bottom (pos. no. 0035) by means of the screws (A and B). Place the product on its edge on an even table, front pointing downwards (be careful not to scratch). (Screws at the bottom must be loosened).

When the top edge touches the table the bottom screws are tightened, - the cabinet is now correctly mounted!

Frontpanel

Front panel

FOR SERVICE MANUALS  
CONTACT:  
**MAURITRON TECHNICAL SERVICES**  
www.mauritron.co.uk  
TEL: 01844 - 351694  
FAX: 01844 - 352554

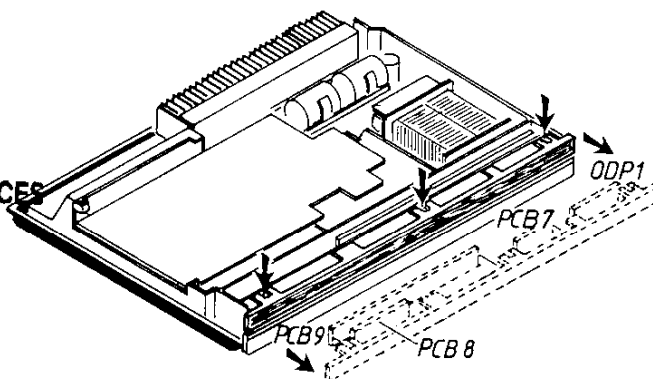

De tre viste skruer (ved pilene) løsnes.  
Frontpanelet kan nu trækkes ud.  
PCB9 kan afmonteres og PCB7, PCB8 og DP1 er nu tilgængelige.

Loosen the three screws shown (at the arrows).  
The front panel can now be pulled out. PCB9 can be removed and PCB7, PCB8 and DP1 are now accessible.

Betjeningspanel

Control panel

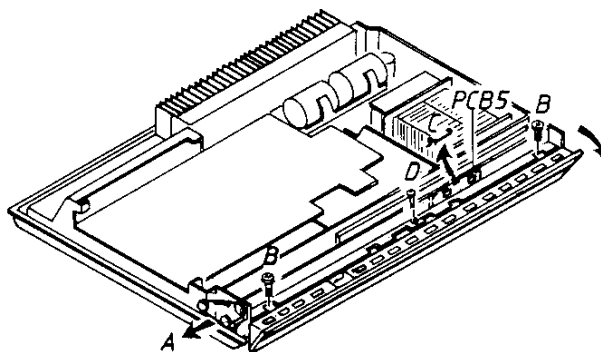

Snoretræk (A) afmonteres.  
De to skruer (B) fjernes.  
Skruen (D) fjernes.  
Den viste printholder (C) ved båndkabel forbindelsen fjernes og betjeningspanelet kan nu afmonteres.

Dismantle cord and pulley (A).  
Remove the two screws (B).  
Remove the screw (D).  
Remove the PCB retainer (C) at the band cable connection. The control panel can now be removed.

Betjeningspanel/Frontpanel

Control panel/front panel

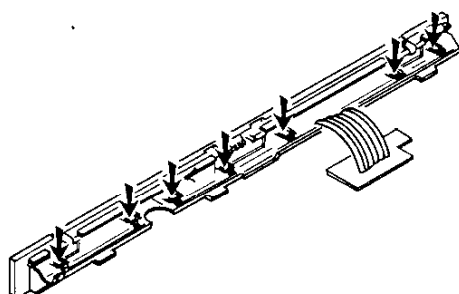

Låsetappene (ved pilene) frigøres med en skrue-trækker eller lignende.  
Betjeningspanelet kan nu adskilles fra frontpanel.

Loosen the retainer pins (at the arrows) with e.g. a screw driver.  
The control panel can now be separated from the front panel.

PCB1

PCB1

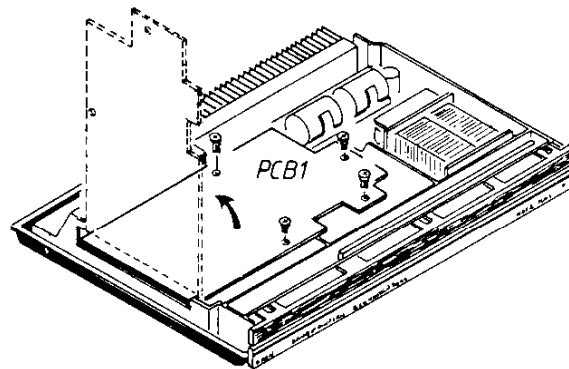

De fire skruer fjernes.  
PCB1 kan nu anbringes i service stilling som vist.

Remove the four screws.  
PCB1 can now be placed in service position as shown.

PCB4

PCB4

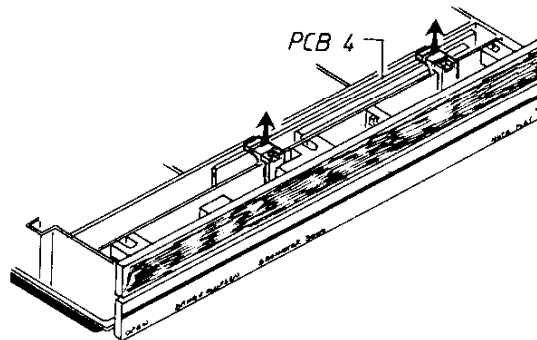

De to plastholdere (ved pilene) tages af (ved at trække i den).  
PCB4 kan nu løftes op.

Pull out the two plastic retainers.  
PCB4 can now be lifted out.

Hus og blæser

Housing and fan

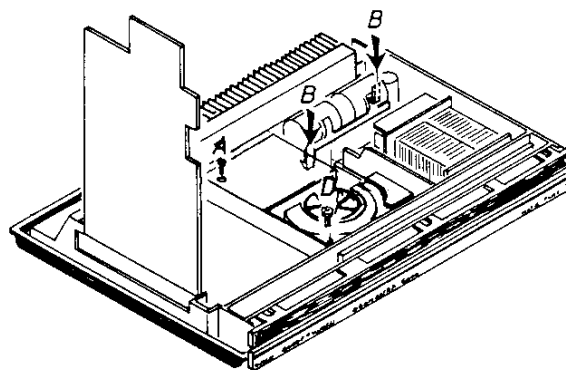

Fjern skruen (A).  
Frigør de to plasttapper (B). Huset kan nu afmonteres.  
Skruen D fjernes.  
Blæseren kan nu løftes op.

Remove the screw (A).  
Loosen the two plastic pins (B). The housing can now be dismantled.  
Remove the screw (D).  
The fan can now be lifted out.

Master Control

Master Control

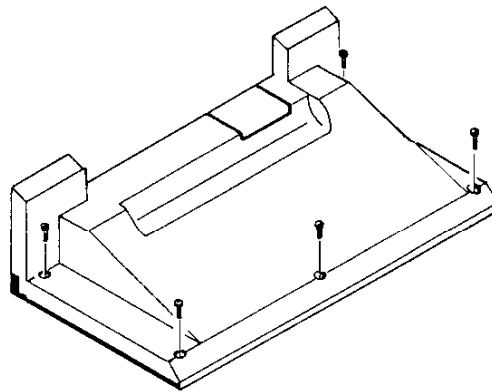

De 5 viste skruer fjernes.

Remove the 5 screws shown.

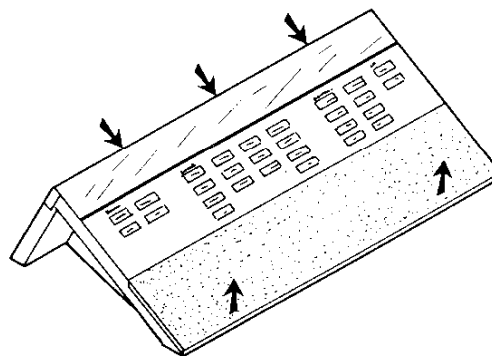

Betjeningspanel løftes lidt i forkanten og der presses de 3 viste steder i bagkanten (hørbart klik).  
Panelet kan nu løftes af.

Lift up control panel slightly in the front edge, and push at the rear edge in the three points shown (a click can be heard).  
The panel can now be removed.

FOR SERVICE MANUALS  
CONTACT:  
**MAURITRON TECHNICAL SERVICES**

[www.mauritron.co.uk](http://www.mauritron.co.uk)  
TEL: 01844 - 351694  
FAX: 01844 - 352554

---



## SERVICETIPS OG MODIFIKATIONER

Reparation i frekvenstæller og afstemningssystemet  
Ved reparation i frekvenstæller og afstemningssystemet kan det være vanskeligt af lokalisere en fejl. Følgende servicetips kan benyttes til at »åbne sløjfen« mellem microcomputeren og afstemningssystemet.

## 1. Frekvenstæller:

Anoden af 1D9C3 kortsluttes til stel.

## FM

Afmonter hunstikket på 1P4B2 og tilslut en målesender til hunstikket. Målesenderen indstilles til FM og en frekvens på f.eks. 100,7 MHz >10 mV.

Modtageren indstilles til FM, MANUAL off. Modtagerens frekvensdisplay skal nu vise en frekvens der er 10,7 MHz under målesenderens frekvens, i dette tilfælde 90 MHz.

## AM

Afmonter hunstikket på 1P2F1 og tilslut en målesender til hunstikket. Målesenderen indstilles til MW og en frekvens på f.eks. 1,16 MHz >10 mV.

Modtageren indstilles til MW, MANUAL off. Modtagerens frekvensdisplay skal nu vise en frekvens der er 460 kHz under målesenderens frekvens, i dette tilfælde 700 kHz.

## 2. Afstemningsspænding:

Afmonter hunstikket 1P4B2 og tilslut en målesender til hunstikket.

Oscilloscop tilsluttes ben 7 på 11C6F4. DC voltmeter tilsluttes kollektor på 1TR14F3. Målesenderen indstilles til FM og en frekvens på f.eks. 100,7 MHz >10 mV.

Modtageren indstilles på 90 MHz MANUAL on (LOCKED lampen skal være slukket).

Med målesenderens frekvenskontrol reguleres frekvensen langsomt op. Microcomputeren vil opfatte dette som oscillator drift mod en højere frekvens, og det vil resultere i korrektionspulser fra microcomputeren. Dette kan ses som positive pulser på oscilloscopet, og faldende spænding på voltmeteret. Pulsernes bredde er udtryk for frekvensafvigelsens størrelse.

(Regulering mod lavere frekvens = negative pulser og stigende spænding på voltmeteret).

## 3. Oscillatorer og HF:

Anoden af 1D9C3 kortsluttes til stel.

1R128E3 løftes (den side af 1R128 som vender mod 1TR14 loddes fra).

En variabel DC strømforsyning tilsluttes med + til den fraloddede side af 1R128.

## SERVICE TIPS AND MODIFICATIONS

## Repairs in the Frequency Counter and the Tuning system

In repair situations involving the frequency counter and the tuning system it may be difficult to localize a fault. The following service tips can be used for »opening the loop« between the microcomputer and the tuning system.

## 1. Frequency counter:

Short-circuit the anode of 1D9C3 to the chassis.

## FM

Remove the female socket on 1P4B2 and connect a signal generator to the female socket. Set the signal generator in FM mode and at a frequency of e.g. 100.7 MHz >10 mV.

Set the receiver in FM, MANUAL off mode.

The frequency display of the receiver shall now indicate a frequency which is 10.7 MHz below the frequency of the signal generator, in this case 90 MHz.

## AM

Remove the female socket on 1P2F1 and connect a signal generator to the female socket. Set the signal generator in MW mode and at a frequency of e.g. 1.16 MHz >10 mV.

Set the receiver in MW, MANUAL off mode.

The frequency display of the receiver shall now indicate a frequency below the frequency of the signal generator, in this case 700 kHz.

## 2. Tuning voltage:

Remove the female socket 1P4B2 and connect a signal generator to the female socket.

Connect an oscilloscope to pin 7 on 11C6F4.

Connect a DC voltmeter to the collector on 1TR14F3.

Set the generator in FM mode and at a frequency of e.g. 100.7 MHz >10 mV.

Set the receiver at 90 MHz MANUAL on.

(The LOCKED lamp shall be off).

Regulate the frequency slowly upwards, by means of the frequency control of the signal generator. The microcomputer will comprehend this as oscillator drifting towards a higher frequency and this will result in corrective pulses from the microcomputer. This can be seen as positive pulses on the oscilloscope and declining voltage on the voltmeter. The extent of the frequency deviation is expressed by the pulse width.

(Regulating towards lower frequency = negative pulses and rising voltage on the voltmeter).

## 3. Oscillators and RF:

Short-circuit the anode of 1D9C3 to the chassis.

Lift 1R128E3 (Unsolder the section of 1R128 which faces 1TR14).

Connect a variable DC power supply with + to the unsoldered side of 1R128.

Når DC spændingen på strømforsyningen varieres, skal modtagerens frekvensdisplay følge variationen. Variationen er på FM fra ca. 2,5 V til 20 V, og på AM fra ca. 2 V til 25 V.

Ved at tilslutte en målesender/sweepgenerator til antenneindgangen, indstille den til 87,5 MHz og indstille DC strømforsyningen på ca. 3 V, kan HF funktionerne kontrolleres.

When the DC voltage on the power supply is varied, the frequency display of the receiver shall follow the variation. On FM the variation is from approx. 2.5 V to 20 V, and on AM from approx. 2 V to 25 V.

The HF functions are controllable by connecting a signal generator/sweep generator to the aerial input, setting it at 87.5 MHz and setting the DC power supply at approx. 3 V.

## Hovedtelefonstik

Efter produktion af ca. 1500 apparater ændres hovedtelefonstikket fra en brydekontakt til en sluttekontakt. Diagrammet i afsnit 1 er gældende for hovedtelefonstik med sluttekontakt. Nedenstående diagramudsnit viser hovedtelefonstik med brydekontakt.

## Headphone Sockets

After the production of approx. 1500 sets the headphone socket has been modified from a break switch to a make switch. The diagram in section 1 is applicable to headphone sockets with make switch. The below diagram section shows a headphone socket with break switch.

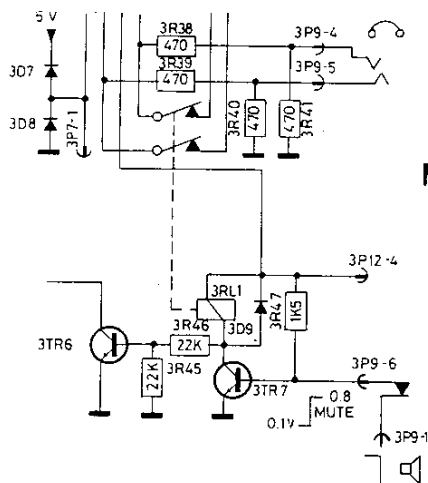

FOR SERVICE MANUALS  
CONTACT:  
**MAURITRON TECHNICAL SERVICES**  
www.mauritron.co.uk  
TEL: 01844 - 351694  
FAX: 01844 - 352554

Der lagerføres kun hovedtelefonstik med sluttekontakt, samt modul 3 beregnet for hovedtelefon med sluttekontakt.

Ved udskiftning af modul 3 eller hovedtelefonstik i apparater med brydekontakt skal følgende foretages:

### 1. Udskiftning af modul 3:

Hovedtelefonstikket udskiftes sammen med modul 3 eller modul 3 ændres til nedenstående.

Only headphone socket with make switch are stocked together with module 3 intended for headphone with make switch.

When replacing module 3 or headphone socket in sets with break sockets, the following procedure shall be followed:

### 1. Replacement of module 3:

Replace the headphone socket together with module 3, or modify module 3 according to the diagram below.

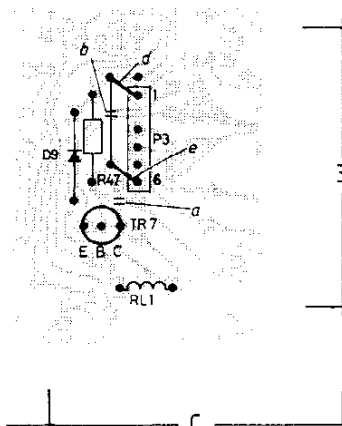

Printet afbrydes i punktet (a).  
Kortslutning (b) afmonteres.  
Kortslutningerne (d) og (e) monteres.

## 2. Udskiftning af hovedtelefonstik:

Interrupt the PCB at the point (a).  
Remove short-circuit (b).  
Fit the short-circuits (d) and (e).

## 2. Replacement of headphone socket:

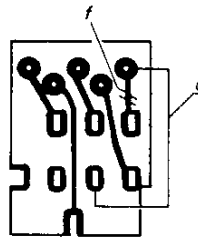

Printet afbrydes i punktet (f).  
Kortslutning (g) monteres.

Interrupt the PCB at the point (f).  
Fit the short-circuit (g).

### Afmontering af stik

Ved afmontering af stik i apparatet må der ikke trækkes i ledningerne til stikket.

### Dismantling of socket

When removing socket from the set do not pull the wires for the socket.

### Testprogram Microcomputer

Microcomputeren har indbygget et selvtest program.  
Aktivering af testprogram:  
Aktiver SELECT derefter TAPE 1 og MANUAL, hold alle tre knapper aktiveret samtidig. Hvis displayet viser aktuel volume efter ca. 5 sek. er microcomputeren OK.

### Microcomputer Test Program

The microcomputer has an integrated autotesting program.  
Activation of testing program:  
Activate SELECT, then TAPE 1 and MANUAL, keep all three buttons activated simultaneously. In case the display indicates actual volume after approx. 5 seconds, the microcomputer is OK.

Viser display:

0 = RAM 4IC2 defekt  
2 = ROM 4IC2 defekt  
4 = ROM 4IC1 defekt

If the display shows:

0 = RAM 4IC2 is defective  
2 = ROM 4IC2 is defective  
4 = ROM 4IC1 is defective

FOR SERVICE MANUALS  
CONTACT:  
**MAURITRON TECHNICAL SERVICES**  
www.mauritron.co.uk  
TEL: 01844 - 351694  
FAX: 01844 - 352554

Tilslutning af nettransformer/  
Connection of Mains Transformer

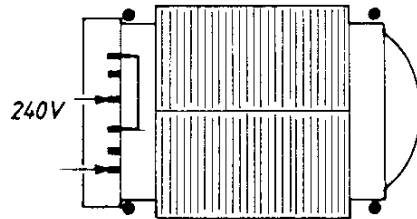
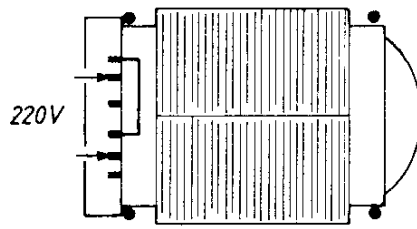

FOR SERVICE MANUALS  
CONTACT:  
**MAURITRON TECHNICAL SERVICES**  
[www.mauritron.co.uk](http://www.mauritron.co.uk)  
TEL: 01844 - 351694  
FAX: 01844 - 352554

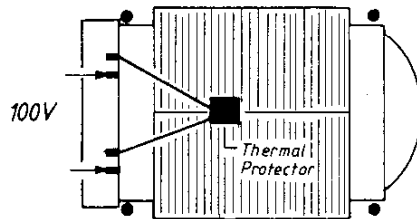
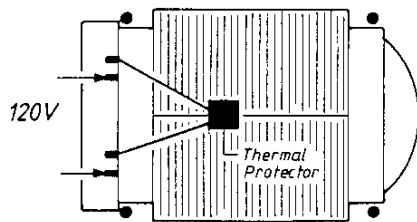
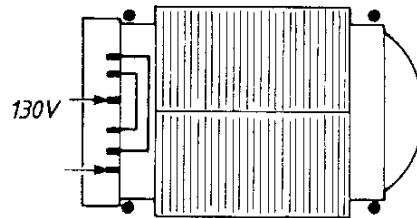
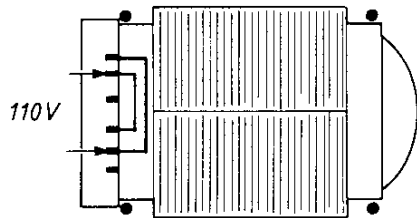

**ISOLATIONSTEST**

Ethvert apparat **skal** isolationstestes efter at det har været adskilt. Testen udføres når apparatet igen er helt samlet og klar til udlevering til kunden.

**Isolationstest for Beomaster 5000**

Isolationstesten udføres på følgende måde:

De to stikben på netstikket kortsluttes og tilsluttes en af terminalerne på isolationstesteren. Den anden terminal fra isolationstesteren tilsluttes stelbenet i hovedtelefonstikdåsen.

**OBS!**

For at undgå beskadigelser på apparatet er det vigtigt, at begge terminaler fra isolationstesteren har virkelig god mekanisk kontakt.

Der drejes nu langsomt med spændingsreguleringen på isolationstesteren indtil en spænding på 1,5 - 2 kV er opnået. Her skal den holdes i 1 sekund, derefter drejes der langsomt ned for spændingen igen.

Der må ikke på noget tidspunkt under testen forekomme overslag.

**INSULATION TEST**

Each set **must** be insulation tested after dismantling. The test is to be performed when the set has been re-assembled and is ready for delivery to the customer.

**Insulation test for Beomaster 5000**

Make the insulation test as follows: Short-circuit the two plug pins of the mains plug and connect one of the terminals of the insulation tester. Connect the other terminal of the insulation tester to the chassis pin of the headphone socket.

**N.B.!**

To avoid ruining the set, it is essential that both insulator test terminals are in really good mechanical contact.

Now turn slowly the voltage control of the insulation tester until a voltage of 1.5 - 2 kV is obtained. Hold it there for 1 second, then turn slowly the voltage down again.

At no point during the testing procedure any flash-overs are permissible.

FOR SERVICE MANUALS  
CONTACT:  
**MAURITRON TECHNICAL SERVICES**  
[www.mauritron.co.uk](http://www.mauritron.co.uk)  
TEL: 01844 - 351694  
FAX: 01844 - 352554

---

## AFPRØVNING AF BEOMASTER 5000

Tilslut:

4 X højttalere.

Båndoptager med datalink til TAPE 1 og TAPE 2.

Båndoptager til AUX.

Grammofon med datalink til PHONO.

Slutafprøvning afsnit 10 skal foretages i rækkefølgen side 10-3/10-4 derefter 10-1/10-2/

OPERATION	FEEDBACK	
	Tast (betjening)	Bemærkninger
OPEN	Betjeningspanelet vipper ud med afdæmpet hastighed	
SELECT ..... SELECT ↓ P1 ..... P9	Foretag lyttetest	P ..... P ↓ ↓ P1 P9
FM-LW-MW ↓ ADVANCE (hvis LOCKED lyser gentryk ADVANCE). (Hvis STEREO lyser, tryk FM MONO og STEREO skal slukke).	Foretag lyttetest  Foretag lyttetest tavs imellem stationerne  <b>FOR SERVICE MANUALS CONTACT:</b> <b>MAURITRON TECHNICAL SERVICES</b> www.mauritron.co.uk TEL: 01844 - 351694 FAX: 01844 - 352554	FMB 7.5MHz  FMB 1.5.....108 MHz (LOCKED hvis der stoppes på station) (STEREO hvis der stoppes på stereo station).
MANUAL ↓ RETURN (hold nedtrykket) ↓ RETURN FAST (hold nedtr.)		FM 108 MHz MANUAL ↓ FM 108 ... 87.5 MHz MANUAL FM 108 ... 87.5 (hurtigere skift på display).
FM-LW-MW ↓ FAST ADVANCE ↓ FM-LW-MW ↓ FAST ADVANCE ↓ STORE	Foretag lyttetest  Foretag lyttetest	LW 150 kHz MANUAL ↓ LW 150 ... 350 kHz MANUAL ↓ MW 520 kHz MANUAL ↓ MW 520 ... 1610kHz MANUAL ↓ P (blinker) → MW 1610 KHz MANUAL
TAPE 1 ↓ TAPE 2 ↓ PHONO ↓ AUX	Foretag lyttetest og test af Data Link  Foretag lyttetest og test af Data Link  Foretag lyttetest og test af Data Link  Foretag lyttetest og test af Data Link	TP1  TP2  PH  PU

OPERATION	FEEDBACK	
Tast (betjening)	Bemærkninger	Display
NEUTRAL ↓ LOUDNESS	<sup>4)</sup> Balance, Bas og Diskant stilles i neutral stilling. Foretag lyttetest	RU (blinker 1 gang) ↓ LOUDNESS RU
Tilslut hovedtelefon	Foretag lyttetest (højtalersæt 1 afbrydes)	
▲VOLUME ▼VOLUME	Foretag lyttetest Foretag lyttetest	0:0 → 0:2...6:0 6:0 ... 0:0
MUTE	Mute og efter 2 sek. ST.BT	Decimal punkt (ST.BY)

<sup>4)</sup>Balance, bas og diskant kan kun reguleres fra MCP.

FOR SERVICE MANUALS  
CONTACT:  
**MAURITRON TECHNICAL SERVICES**  
www.mauritron.co.uk  
TEL: 01844 - 351694  
FAX: 01844 - 352554

## SLUTAFPRØVNING EFTER REPARATION

Denne slutafprøvning gælder for Master Control Panel 5000 (MCP) og Beomaster 5000.

OPERATION	FEEDBACK	
	Display MCP	Display Beomaster 5000
Tast (betjening) MCP	Display MCP	Display Beomaster 5000
Tilslut Beomaster til lysnet (efter 1 min. uden tilslut til lysnet)		Decimal punkt (ST.BY)
P1 til P9	Set clock P1 ... P9	P1 ... P9
TAPE 1 ↓ TAPE 2 ↓ PHONO ↓ AUX-CD	TP1 ↓ TP2 ↓ PH ↓ AU	TP1 ↓ TP2 ↓ PH ↓ AU
SET CLOCK ↓ 8 (4 gange) ↓ STORE (på primær panel)	SET CLOCK SUN <sup>1)</sup> ↓ SET CLOCK SUN 88:88 ↓ SET CLOCK SUN 8888 derefter 2	AU ↓ AU ↓ AU
PLAY ↓ 0 (5 gange) ↓ DAY (7 gange) ↓ STORE (på sekundær panel)	PLAY SUN ↓ PLAY 0 SUN 00:00 ↓ PLAY 0 ALL→MON→TUE→WED→ THUR→FRI→SAT 0000 ↓ PLAY 0 SAT 0000	AU ↓ AU ↓ AU ↓ AU
STEP (indtil displayet viser) ↓ CLEAR (medens displayet lyser)	→ PLAY 0 SAT 00:00 ↓ mørk display	AU ↓ AU
STEP (indtil displayet viser)	NO INPUT	AU
TRACK	T	AU
PLAY NEXT ↓ P1	PLAY NEXT ↓ PLAY NEXT P1→AU	AU ↓ AU



OPERATION	FEEDBACK	
Tast (betjening) MCP	Display MCP	Display Beomaster 5000
P1 ↓ << AUX ↓ >> ↓ RETURN (hvid) ↓ ADVANCE ↓ STOP ↓ TAPE STOP ↓ RETURN (grøn) ↓ RECORD (primær panel)	P1 ↓ FM RU RU >> RU << RU >> RU << >> RU RECORDING POSSIBLE RU << RECORDING RU RECORDING	P1 ↓ FM 108 → 107.9 ... 87.5 MHz RU RU RU RU RU RU RU RU
RECORD (sekundær panel)	RECORD SUN	RU
CONTROL	☐	RU
▼VOLUME og ▲VOLUME ↓ ◀BALANCE og BALANCE▶ ↓ ▲BASS og ▼BASS ↓ ▲TREBLE og ▼TREBLE ↓ MUTING	VOL. BAL. BASS TREBLE ──── ──── ──── (Volume display regulerer, lys i Bal., Bass og Treble) RU ↓ (Balance display regulerer, lys i Vol., Bass og Treble) RU ↓ (Bass display regulerer, lys i Vol., Bal. og Treble) RU ↓ (Treble display regulerer, lys i Vol., Bal. og Bass) RU ↓ (Vol. display blinker, lys i Bal., Bass og Treble) RU	0:00 0:2 ... 5:8 6:0 ↓ RU ↓ RU ↓ RU ↓ RU
0 ↓ STATUS	☐ ↓ ☐ og aktuel tid fra tilslutning til lysnet	Decimal punkt ↓ Decimal punkt

<sup>1)</sup> Dag og tid indikationen er vilkårlig afhængig af hvor længe apparatet har været afbrudt fra lysnet.  
 Display NO DISC – NO TAPE – IM – BATTERY – NO TRANSMISSION er ikke omtalt i skemaet.

Final test section 10 is to be made in the order 10-7/10-8 thereafter 10-5/10-6

TESTING OF BEOMASTER 5000

Tape recorder to AUX.

Connect:

Gramophone with data link to PHONO.

4 X loudspeakers.

Tape recorder with data link to TAPE 1 and TAPE 2.

OPERATION	FEEDBACK	
Button (operation)	Remarks	Display
OPEN	Operating panel tips out with damped speed	
SELECT ..... SELECT ↓                    ↓ P1 ..... P9	Undertake listening test	P ..... P ↓        ↓ P1      P9
FM-LW-MW ↓ ADVANCE (if LOCKED lights repress ADVANCE). (If STEREO lights, press FM MONO and STEREO must switch off).	Undertake listening test  Undertake listening test (silent between stations)	FM87.5MHz  FM87.5.....108MHz (LOCKED if stopped at station (STEREO if stopped at stereo station)).
MANUAL ↓ RETURN (hold down) ↓ RETURN FAST (hold down)	<b>FOR SERVICE MANUALS</b> <b>CONTACT:</b> <b>MAURITRON TECHNICAL SERVICES</b> <a href="http://www.mauritron.co.uk">www.mauritron.co.uk</a> <b>TEL: 01844 - 351694</b> <b>FAX: 01844 - 352554</b>	FM 108 MHz MANUAL ↓ FM 108 ..... 87.5MHz MANUAL  (Faster shifting in display).
FM-LW-MW ↓ FAST ADVANCE ↓ FM-LW-MW ↓ FAST ADVANCE ↓ STORE	Undertake listening test  Undertake listening test  Undertake listening test	LW 150 kHz MANUAL ↓ LW 150 ..... 350kHz MANUAL ↓ MW 520 kHz MANUAL ↓ MW 520.....1610kHz MANUAL ↓ P (blinking) → MW 1610 KHz MANUAL
TAPE 1 ↓ TAPE 2 ↓ PHONO ↓ AUX	Undertake listening test and test of Data Link Undertake listening test and test of Data Link Undertake listening test and test of Data Link Undertake listening test and test of Data Link	TP1  TP2  PH  AU

OPERATION	FEEDBACK	
Button (operation)	Remarks	Display
NEUTRAL ↓ LOUDNESS	<sup>4)</sup> Balance, Bas and Treble are set in position neutral. Undertake listening test	RU (blinks once) ↓ LOUDNESS RU
Connect headphone	Undertake listening test (loudspeaker set 1 i disconnected)	
▲VOLUME ▼VOLUME	Undertake listening test Undertake listening test	0:0 → 0:2 ... 6:0 6:0 ... 0:0
MUTE	Mute and after 2 sec. ST.BT	Decimal point (ST.BY)

<sup>4)</sup>Balance, Bass and Treble can only be regulated from MCP.

FOR SERVICE MANUALS  
CONTACT:  
**MAURITRON TECHNICAL SERVICES**  
www.mauritron.co.uk  
TEL: 01844 - 351694  
FAX: 01844 - 352554

## FINAL TESTING AFTER REPAIR

This testing is valid for Master Control Panel 5000 (MCP) and Beomaster 5000.

OPERATION	FEEDBACK	
Button (operation) MCP	Display MCP	Display Beomaster 5000
Connect Beomaster to mains (after 1 min. without connection to mains)		Decimal punkt (ST.BY)
P1 til P9	Set clock P1 ... P9	P1... P9
TAPE 1 ↓ TAPE 2 ↓ PHONO ↓ AUX-CD	TP1 ↓ TP2 ↓ PH ↓ RU <div style="text-align: center;"> <p><b>FOR SERVICE MANUALS CONTACT:</b>  <b>MAURITRON TECHNICAL SERVICES</b>  <a href="http://www.mauritron.co.uk">www.mauritron.co.uk</a>            TEL: 01844 - 351694            FAX: 01844 - 352554</p> </div>	TP1 ↓ TP2 ↓ PH ↓ RU
SET CLOCK ↓ 8 (4 times) ↓ STORE (in primary panel)	SET CLOCK SUN <sup>1)</sup> ↓ SET CLOCK SUN 88:88 ↓ SET CLOCK SUN 8888 followed by P	RU ↓ RU ↓ RU
PLAY ↓ 0 (5 times) ↓ DAY (7 times) ↓ STORE (in secondary panel)	PLAY SUN ↓ PLAY 0 SUN 00:00 ↓ PLAY 0 ALL→MON→TUE→WED→ THUR→FRI→SAT 00:00 ↓ PLAY 0 SAT 0000	RU ↓ RU ↓ RU ↓ RU
STEP (until display indicates): ↓ CLEAR (while display lights)	→ PLAY 0 SAT 00:00 ↓ dark display	RU ↓ RU
STEP (until display indicates)	NO INPUT	RU
TRACK	T	RU
PLAY NEXT ↓ P1	PLAY NEXT ↓ PLAY NEXT P1→RU	RU ↓ RU

OPERATION	FEEDBACK	
	Button (operation) MCP	Display MCP
P1 ↓ << AUX ↓ >> ↓ RETURN (white) ↓ ADVANCE ↓ STOP ↓ TAPE STOP ↓ RETURN (green) ↓ RECORD (primary panel)	P1 ↓ FM RU ↓ RU >> ↓ RU << ↓ RU >> ↓ RU << >> ↓ RU RECORDING POSSIBLE ↓ RU << RECORDING ↓ RU RECORDING	P1 ↓ FM108 → 107.9... 87.5 MHz ↓ RU ↓ RU ↓ RU ↓ RU ↓ RU ↓ RU ↓ RU
RECORD (secondary panel)	RECORD SUN	RU
CONTROL	C	RU
▼VOLUME and ▲VOLUME ↓ ◀BALANCE and BALANCE▶ ↓ ▲BASS and ▼BASS ↓ ▲TREBLE and ▼TREBLE ↓ MUTING	VOL. BAL. BASS TREBLE  (Volume display regulate light in Bal., Bass and Treble) RU ↓ (Balance display regulate light in Vol., Bass and Treble) RU ↓ (Bass display regulate light in Vol., Bal. and Treble) RU ↓ (Treble display regulate light in Vol., Bal. and Bass) RU ↓ (Vol. display is blinking in Bal., Bass and Treble) RU	0:0 + 0:2 ... 5:8 + 6:0 ↓ RU ↓ RU ↓ RU ↓ RU
0 ↓ STATUS	0 ↓ 0 and actual time from connection to mains	Decimal point ↓ Decimal point

1) Day and time indication is at random dependant on for how long the set has been disconnected from mains.

Display NO DISC - NO TAPE - IM - BATTERY - NO TRANSMISSION are not mentioned in the table.

Display NO DISC - NO TAPE - IM - BATTERY - NO TRANSMISSION er ikke omtalt i skemaet.