

# BOGEN

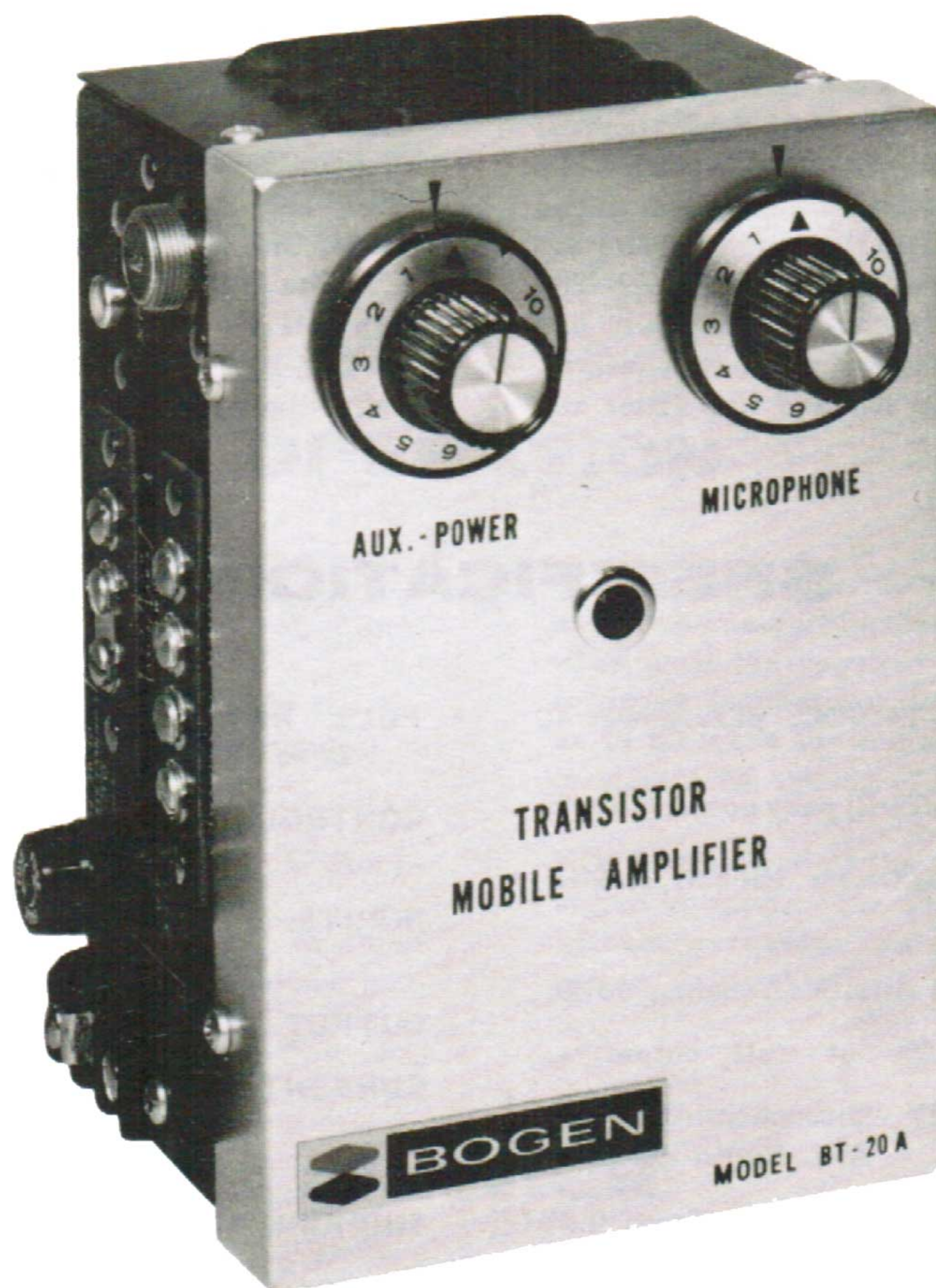

## MODEL BT20A

MOBILE TRANSISTORIZED  
25 WATT P. A. AMPLIFIER

LEAR SIEGLER, INC.



BOGEN DIVISION  
P.O. BOX 500  
PARAMUS, N. J. 07652

## INSTALLATION AND OPERATING MANUAL

READ THOROUGHLY BEFORE OPERATING EQUIPMENT

# DESCRIPTION

The model BT20A represents the latest design in compact high output amplifiers. This amplifier is intended for use in mobile and portable public address work. Separate inputs and individual gain controls are provided for a low impedance microphone, and for high level auxiliary equipment (such as a tuner or tape recorder). The BT20A incorporates an auxiliary and radio input circuit so that the output of a two-way radio (any radio for that matter) may be connected directly to the amplifier. This enables the two-way radio to be heard outside the vehicle and at considerable distances. The possible applications are varied (e.g. the amplifier can be used to distribute music at political rallies, etc.). The BT20A is excellent for such applications as police, fire department, marine, military or general commercial use. The BT20A may also be used as an emergency standby p.a. amplifier in permanent installations in the event of power failure.

The BT20A incorporates built-in RF and line filter cir-

cuits to prevent RF or line noise from being amplified. A fuse provides protection of the unit from inadvertent shorting. The amplifier will operate from the battery of any motor vehicle regardless of grounding polarity.

The unit can be operated from any 5-15 volt DC source. Any battery source such as lantern batteries may be used. The amplifier supplies a full 25 watts output at a maximum power supply current drain of 2.9 amperes at 14 VDC. The quiescent current drain is 0.27 amperes. The frequency response is optimized to provide maximum speech intelligibility. The speaker used with the unit may have an impedance of 4, 8 or 16 ohms and should be capable of handling a minimum of 25 watts. The BT20A will deliver a peak power of 40 watts.

The BT20A is exceptionally temperature stable, operation will not be affected by extreme climatic conditions; from -30°C (-22°F) to +65°C (149°F). The amplifier is compact, lightweight and portable and very rugged in construction.

## SPECIFICATIONS

**OUTPUT POWER:** 25 watts at 14 VDC; peak power 40 watts.

5 watts at 6 VDC; peak power 8 watts.

**RESPONSE:** Optimized for maximum speech intelligibility.

**GAIN:** Microphone Input 110 db. Aux.-Radio Input 90 db.

**DISTORTION:** Less than 10% at full output.

**NOISE:** (Below Rated Output) Microphone -90 db.  
Aux.-Radio -95 db.

**SENSITIVITY:** Microphone 1 millivolt. Aux.-Radio 0.40 volt.

**FULL RATED POWER TEMPERATURE RANGE:**  
-22 to +149 degrees Fahrenheit.

**CONTROLS:** Aux. Volume/Power Switch, Microphone Volume.

**INPUTS:** (2) Microphone (50-500 ohms, 200 ohms nominal), Auxiliary-Radio.

**OUTPUT IMPEDANCE:** 4, 8 or 16 ohms.

**CURRENT DRAIN:** 0.27 amp quiescent (0.1 amp for bulb), 2.9 amperes at full rated output.

**SHIPPING WEIGHT:** 4 lbs.

**DIMENSIONS:** 6½" h x 4½" w x 4" d.

## INSTALLATION

### MOUNTING

The BT20A may be mounted in any position on practically any surface. The unit may be mounted on the frame of a vehicle, or to any convenient surface.

### CONNECTIONS

**POWER:** Two conductors (black and red) consisting of 4 feet each of No. 16 AWG wire are provided with the BT20A for making the power connections. Connect the black wire to the negative side of the DC source marked with a minus sign (-). Connect the red wire to the positive of the DC source, marked with a plus (+) sign. The BT20A is shipped with negative (-) side grounded. If the battery being used has

the positive (+) side grounded, move the shorting strap from the negative to the positive terminal. A VOLTAGE SELECTOR terminal strip with a shorting jumper is provided. If power source is between 5-8 VDC or 9-15 VDC, jumper the appropriate pair of terminals. Check polarity carefully. If the connecting wires and ground polarity strap are not connected properly, the fuse and power transistors may blow. If the fuse blows due to improper polarity, check polarity carefully, and connect properly before replacing fuse and turning on amplifier. Operation from either a positive or negative grounded system is equally permissible. The DC power supply voltage should not exceed 15 volts.

**MICROPHONE:** Any low impedance (500 ohms or less, 200 ohms nominal) microphone may be used with this amplifier. The microphone should be connected to the amplifier using shielded audio cable and a microphone connector Amphenol type 75-MC1F (or equivalent). A plastic cased microphone type 404B is recommended.

**AUXILIARY (RADIO):** This is a high impedance level input for use with phonograph (ceramic or crystal cartridge), any radio or a tape recorder (with a built-in preamplifier). Terminate the output of this type of program source with shielded audio cable and a phono plug. Plug auxiliary source into AUX. input socket.

The output of any radio (e.g. two-way radio) can be connected to this input socket. Connect the two wires from the radio speaker voice coil to a phono type plug. Insert this plug into the AUX. socket. Do not disconnect anything in the radio.

**SPEAKERS:** A terminal strip on the BT20A chassis provides output connections to speakers. The amplifier may be used in conjunction with speakers rated at 4, 8 and 16 ohms. Correct impedance matching between the amplifier output and all speaker systems is essential to obtain maximum power.

The output transformer secondary is completely isolated electrically. Therefore, accidental shorting of speaker output leads to ground will not affect amplifier operation.

**CAUTION:** With alternator type charging systems or any system giving extreme voltage variations, connect the power leads directly to the battery terminals.

The BT20A contains RF and line filters. Losses due to small size wire or poor connections (i.e., vehicle frame connections) may defeat the built-in filter action of the amplifier. This will result in noise being audible.

For best results use a microphone with case at floating potential (both center and outside leads insulated from case).

## OPERATION

### TO AMPLIFY AUXILIARY OR RADIO INPUT

1. Rotate AUX.-POWER switch/volume control, clockwise. Panel lamp will go on.
2. Adjust the AUX. volume control to provide the desired output level. If necessary adjust the volume control on the input source (i.e., radio receiver).

### TO USE AS MICROPHONE AMPLIFIER

1. Rotate AUX.-POWER switch/volume control, clockwise until panel lamp goes on.
2. Make a speech test, using the microphone, to determine the desired setting, of the MICROPHONE volume control.

Starting with the MICROPHONE volume control in the maximum counterclockwise position, rotate the control clockwise until the required sound level is reached. If acoustic feedback (squealing) occurs, either move the microphone so as to increase the distance between it and the loudspeakers or reduce the setting of the MICROPHONE volume control.

**NOTE:** Because of the low quiescent current drain, when no signal is applied, the unit may be left on for extended periods without excessive drain on the battery (provided a storage battery is used).

## SERVICE

### PREVENTIVE MAINTENANCE

A thorough check of the complete system at regular intervals, as a matter of routine, greatly reduces the possibility of failure when system is in use. The output should be checked when microphone is spoken into, or signal source operated. Tests under all operating conditions should be performed.

### IN THE EVENT OF FAILURE OR IMPROPER OPERATION

Check fuse. Be sure AUX.-POWER switch is in OFF position. A 4 ampere fuse is located in a holder. To replace fuse, turn the fuse holder cap counterclockwise, press in, and remove both cap and fuse. Insert another fuse of the same rating and replace cap. If second fuse blows, do not attempt to further operate equipment. Consult an experienced technician or Bogen representative for inspection of the unit.

### BOGEN SERVICE

We are interested in your Bogen unit for as long as you have it.

If trouble ever develops with your unit, please do not hesitate to ask our advice or assistance. Information can be obtained by writing to: Service Department, Bogen Division, P. O. Box 500, Paramus, New Jersey 07652.

When communicating with us, give the model number and series number of your unit. Completely describe the difficulty encountered. Describe the effects each operating control has upon the symptoms of trouble. Include details on electrical connections to associated equipment and list such equipment.

When we receive this information, we will send you service information if the trouble appears to be simple. If trouble requires servicing, we shall send you the name and address of the nearest Bogen authorized service agency to which you can send your unit for repair.

When shipping your unit, pack well, using the equivalent of the original shipping carton and filler material to prevent damage in transit. Send unit, fully insured and prepaid, via railway express. Do not ship via parcel post unless so instructed. The unit will be promptly repaired and returned to you via express collect.

### TRANSISTOR REPLACEMENT

Transistors and semiconductor diodes do not ordinarily require routine testing. When the receiver does not perform properly and it is suspected that a transistor or diode is at fault, only a qualified technician should test them.



Figure 1-Model BT20A Amplifier, Schematic Diagram