

# BOGEN.

## Challenger Solid State Series

# MODEL C10

## 10-WATT TRANSISTOR PUBLIC ADDRESS AMPLIFIER

### OPERATING AND INSTALLATION MANUAL

#### DESCRIPTION

Bogen Model C10 is a fully transistorized public address amplifier rated at 10 watts. The unit will accommodate one high impedance microphone and one auxiliary program source such as a tuner, tape recorder, or phonograph with ceramic cartridge. Individual controls are provided for the microphone and auxiliary inputs along with a treble control for adjustment of tonal balance.

Balanced or unbalanced outputs are provided for 4, 8, and 16-ohm speakers, and 25-volt (62.1 ohms) or 70-volt (490 ohms) constant-voltage systems. A terminal strip with screw terminals allows convenient connection of speakers, except 70-volt. For 70-volt operation, a quick-disconnect speaker socket is provided.

The C10 operates from a 120-volt, 60Hz source and has a maximum power consumption of 46 watts. A thermostat enclosed in the power transformer protects the amplifier against overloads.

#### INSTALLATION

##### UNPACKING

The amplifier was carefully checked before leaving the factory. Inspect shipping container and unit carefully for indication of improper handling; if the unit has been damaged, make an immediate claim to distributor from whom it was purchased, or if the amplifier was shipped directly to you, notify transportation company without delay and place your claim.

##### POWER AND GROUNDING

The amplifier is furnished with an ac line cord terminated in a three-prong plug. The line cord should be plugged into a three-wire grounded outlet providing a nominal 120-volt, 60 Hz power source. This will ground the amplifier as well as supply power to it.

It is important to ground the amplifier. Therefore, if a three-wire outlet is not available, an adapter such as Leviton No. 5017 should be used to convert a standard two-wire outlet for use with three-wire plugs. The adapter is provided with a grounding pigtail which should be connected to the screw holding the wall plate to the receptacle.

In some areas, the wall plate screw is not grounded. In this case it will be necessary to connect a grounding wire from the GND terminal on the rear chassis of the amplifier to a water or steam pipe.

#### TECHNICAL SPECIFICATIONS

**POWER OUTPUT:** 10 Watts.

**FREQUENCY RESPONSE:** 80 to 10,000 Hz  $\pm 2$  dB.

**HUM AND NOISE:**

MIC Input 60 dB below rated output.

AUX Input, 70 dB below rated output.

**SENSITIVITY:** MIC Input 3 mV; AUX Input 0.3V

**INPUTS:** 1 Hi-Z MIC convertible to Lo-Z balanced (150-200 ohms) with IT-1 accessory. AUX Input Hi-Z. Provision for WMT-1.

**OUTPUTS:** Speaker 4, 8, and 16-ohms, 25 volt (62.1 ohms), and 70 volt (490 ohms) line. Screw terminals on terminal strip for speaker connections.

**TONE CONTROL ACTION:**

TREBLE 10 kHz, -11 dB.

**CONTROLS:** Microphone Volume, AUX Volume, Treble.

**SEMICONDUCTORS:** All Silicon, 7 Transistors 4 Diodes

**POWER CONSUMPTION:** 46 W, 120 VAC, 60 Hz.

**DIMENSIONS:** 11-3/8" W x 2-7/8" H x 7-3/4" D.

**WEIGHT:** 5 lbs.

#### INPUT CONNECTIONS

**MICROPHONE:** Connect the microphone to the MIC receptacle on the rear panel.

The microphone should be of the high-impedance ceramic, or dynamic type. Connect the microphone as shown in figure 1. The length of the interconnecting cable should be under 35 feet. Where longer lines are necessary, a low impedance microphone should be used along with Model IT-1, in-line type microphone transformer.

**MICROPHONE PRECEDENCE:** Microphone precedence may be accomplished by connecting the circuit shown in

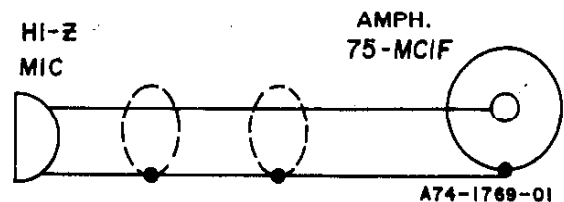

Figure 1 - Connecting Hi-Z Mic

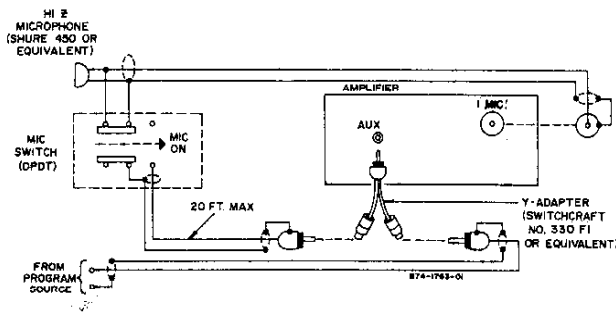

Figure 2 — Microphone Precedence Circuit

figure 2. The equipment consists of a microphone, a Y-adapter (Switchcraft Part No. 330F1), a single-conductor shielded cable (20 feet maximum length) and a SPDT switch. If the microphone switch has an extra set of contacts for controlling an external circuit, such as on the Shure Model 450, the SPDT switch is not required.

Plug the Y-adapter into the AUX input jack on the rear of the amplifier. Connect the program source and precedence switch to the Y-adapter, as shown in the figure. Connect the microphone input to the MIC input jack.

**PHONO:** Connect a phonograph (with ceramic cartridge) to the AUX jack, using a single-conductor shielded cable terminated in a standard RCA phono plug. It is recommended that a separate ground wire be connected between the phono player base and the amplifier GND terminal to minimize hum pick-up.

**TUNER, TAPE, ETC.:** The AUX input may be used for sources other than a phonograph. Any signal source having a high-level (.15-3V) output may be connected to these inputs. This includes such Bogen equipment as the Model BRC 3-speed automatic record changer, and Model TP160 AM/FM tuner.

## OUTPUT CONNECTIONS

**SPEAKERS:** The amplifier may be used with speaker systems rated at 4, 8 and 16 ohms and with 25-volt and 70-volt constant voltage systems. For detailed information on the installation of multiple speaker systems, refer to the Speaker Installation Bulletin (no. 54-5001) included.

In permanent installations, where speakers will remain connected to the amplifier, connect the speaker system directly to the Speaker Output terminals on the rear of the amplifier. Connect one speaker lead to the COM terminal and the other to the terminal corresponding to the impedance of the speaker system.

### CAUTION

To minimize shock hazard, Class 1 wiring as defined in local building codes should be used for 70-volt outputs. All other outputs may use Class 2 wiring.

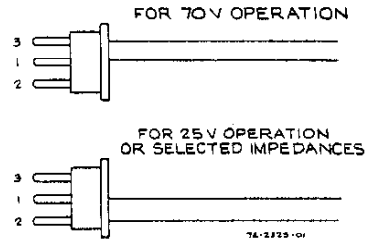

Figure 3 — Speaker Output Plug Wiring

When the speaker socket is used, connect the wired plug to the socket. Attach the impedance selector lead to the output terminal which corresponds to the speaker system impedance. For 70-volt operation, it is only necessary to connect the wired plug to the quick-disconnect speaker socket, leaving the impedance selector disconnected. Note that the arrangement in figure 4 is for unbalanced speaker lines, with the link between COM and GND closed. For balanced lines, open the link between COM and GND.

### NOTE

For balanced output lines, remove the link between COM and GND output terminals. If the line is shielded, connect the shield to GND.

## CONNECTING AMPLIFIERS IN SERIES

Pairs of Bogen C10 amplifiers can be connected in series to effectively double the power output into the same speaker system. See figure 4 for connection diagram. Be certain to remove the link between COM and GND of amplifier No. 2. Note that this arrangement is for unbalanced speaker lines. For balanced lines also remove the link between COM and GND of amplifier No. 1.

The input cabling must be arranged to parallel the inputs of the two amplifiers, and the volume and tone controls of both amplifiers must be at the same setting to assure that each amplifier will share the load equally.

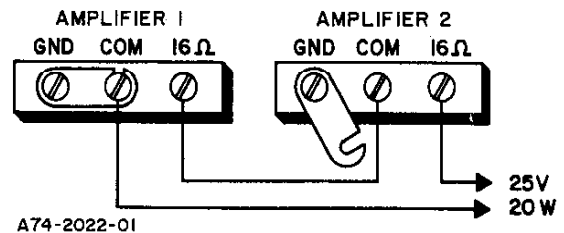

Figure 4 — Connecting Amplifiers in Series

## OPERATION

**POWER:** The POWER switch on the front panel turns the amplifier ON or OFF.

**MIC:** The MIC control on the front panel is used to adjust the volume of the microphone input. Rotate the control clockwise (to the higher numbers) to increase volume. Set the control to the minimum position (0) when the microphone input is not used.

**AUX:** The AUX control adjusts the volume of the auxiliary input.

**TREBLE:** Use the TREBLE control to adjust the tonal balance of the amplifier output. The maximum clockwise position provides flat frequency response and counter-clockwise produces high frequency attenuation. This control can also be used to remove high-frequency noise (such as record scratch) by rotating it in the counter-clockwise direction.

## ACCESSORIES

**WMT-1 LINE MATCHING TRANSFORMER:** The Bogen WMT-1 line-matching transformer provides an impedance match between the amplifier and a 0 level, 500/600-ohm line. This may be a telephone line connected to the switchboard for internal paging or used with a wired music system. No soldering is required to connect the WMT-1 to the amplifier.

To connect the input from a balanced 500/600-ohm telephone line, mount the WMT-1 on the rear panel of the amplifier, using the holes indicated on the rear panel. Connect the input line to the three-screw terminal board on the WMT-1. Connect the phono plug on the WMT-1 cable to the AUX jack on the rear of the amplifier. If this jack is being used for other sound inputs, the WMT-1 may be connected to the MIC input. In order to do this, the WMT-1 wiring must be modified as described in the instruction sheet supplied with the WMT-1.

**MODEL BRC RECORD CHANGER:** This accessory is a 3-speed ac operated record player and automatic record changer. A tone arm housing a dual-stylus flip-over cartridge for standard or LP records is furnished with the unit.

**RPK-35 RACK PANEL:** The Bogen Model RPK-35 rack panel is designed to mount the amplifier in a standard 19-inch sound rack. The rack panel is finished in gray enamel.

**WMK-1 IN-WALL MOUNTING KIT:** The Bogen Model WMK-1 In-Wall Mounting Kit is designed to mount the amplifier flush in a wall. Depth of the mounted unit is 3¼ inches.

**IT-1 IN-LINE MICROPHONE TRANSFORMER:** The IT-1 features full frequency response 20 - 20,000 Hz, magnetically shielded, matches 150 - 250 ohm microphones to Hi-Z inputs. The input connector is Cannon XLR-3-12 and the output connector is Switchcraft 250-1F.

## MAINTENANCE

### CAUTION

*There are no user replaceable parts within the unit. Have all internal servicing done by a qualified technician.*

### BOGEN SERVICE

We are interested in your Bogen equipment for as long as you have it. If trouble ever develops, do not hesitate to ask our advice or assistance. Information can be obtained by writing to Service Department, Bogen Division, P.O. Box 500, Paramus, N.J. 07652.

When communicating with us, give the model and series designation of your unit. Describe the difficulty and include details on the electrical connections to associated equipment, and list such equipment. When we receive this information, we will send you service information if the trouble appears to be simple. If the trouble requires servicing, we shall send you the name and address of the nearest Bogen authorized service agency to which you can send your unit for repairs.

When shipping your unit, pack the amplifier well, using the original shipping carton, or a similar container and filler material, to prevent damage in transit. Send the unit, fully insured and prepaid, via railway express. Do not ship via parcel post unless so instructed. The unit will be promptly repaired and returned to you express prepaid.

### OVERLOAD PROTECTION

The amplifier output is protected against overload and shorted speaker lines by a thermostat enclosed in the power transformer. If the breaker opens, the amplifier will have no output. Set the ac power switch to off and wait a reasonable time for the breaker to reset. Return the ac power switch to on. If the breaker trips again, do not attempt to reset it but have the trouble investigated by a qualified technician.

### REPLACING TRANSISTORS

When replacing the output transistors, clean all foreign matter from the heat sink, insulator, and transistor. Brush a generous amount of silicon compound such as Dow Corning No. 340 to completely cover both surfaces of the insulator (Part No. 16-9278-01). Place the insulator between the heat sink and the replacement transistor. Use the original transistor mounting hardware to mount the replacement transistor.

### CAUTION

*All transistors are soldered to ensure maximum reliability. When soldering leads, use a heat sink (such as a small alligator clip) between the transistor and the source of heat.*

# REPLACEMENT PARTS

Most components are standard parts available through reputable parts jobbers. The parts listed here may be obtained from Bogen distributors, service agencies or directly from the factory. When ordering a part, specify a part number and description of the part as listed. Specify the model of the unit and give the series designation, which is a letter followed by numbers, printed on the chassis. For parts on circuit boards, also give the component board assembly number, which begins with "45."

When replacing transistors, use those made by the specified manufacturers. Transistors from other suppliers may not be satisfactory. Certain resistors must be Allen-Bradley. These are designated by "AB" on the schematic diagram.

Ref. No.	Part No.	Description
CR1,CR2	96-5193-01	Diode, 200 PIV, 2A
CR3	96-5202-01	Diode, HVR3
CR4	96-5333-01	Diode, 400 PIV, 1A
Q1	96-5213-01	Transistor, 2N5089 (Motorola) or
	96-5314-01	Transistor, BC149C (Siemens) or
	96-5335-01	Transistor, TP109C (Sprague) or
	96-5346-01	Transistor, BC239C (Siemens)
Q2	96-5298-01	Transistor, SPS-1910 (Motorola)
Q3, Q5	96-5283-01	Transistor, MPS A55 (Motorola)
Q4	96-5290-01	Transistor, MPS A05 (Motorola)
R4	77-001-712	Control, AUX Volume, 2 Meg.
R11	77-001-711	Control, MIC Volume, AUX Volume, 1 Meg.
R12	77-001-731	Control, TREBLE, 1 Meg.
R30	76-113-099	Resistor, 0.27 ohm, 5W

Ref. No. Part No. Description

## A1 - COMPONENT BOARD ASSEMBLY PART NO. 45-9915-01

C10	79-112-006	Capacitor, Electrolytic, 1000 $\mu$ F, 55V
C11	79-008-058	Capacitor, Electrolytic, 10 $\mu$ F, 50V
C12	79-008-064	Capacitor, Electrolytic, 330 $\mu$ F, 50V
C16,C17	79-008-062	Capacitor, Electrolytic, 100 $\mu$ F, 50V
C21	79-112-004	Capacitor, Electrolytic, 500 $\mu$ F, 40V

## Chassis Electrical Parts

Q101	96-5232-03	Transistor
Q102		
SW101	81-003-060	Switch, Power
T101	83-772-000	Transformer, Power (with 110-degree thermostat enclosed in transformer)
T102	83-434-000	Transformer, Output

## Front Panel Parts

03-0651-01 Knob

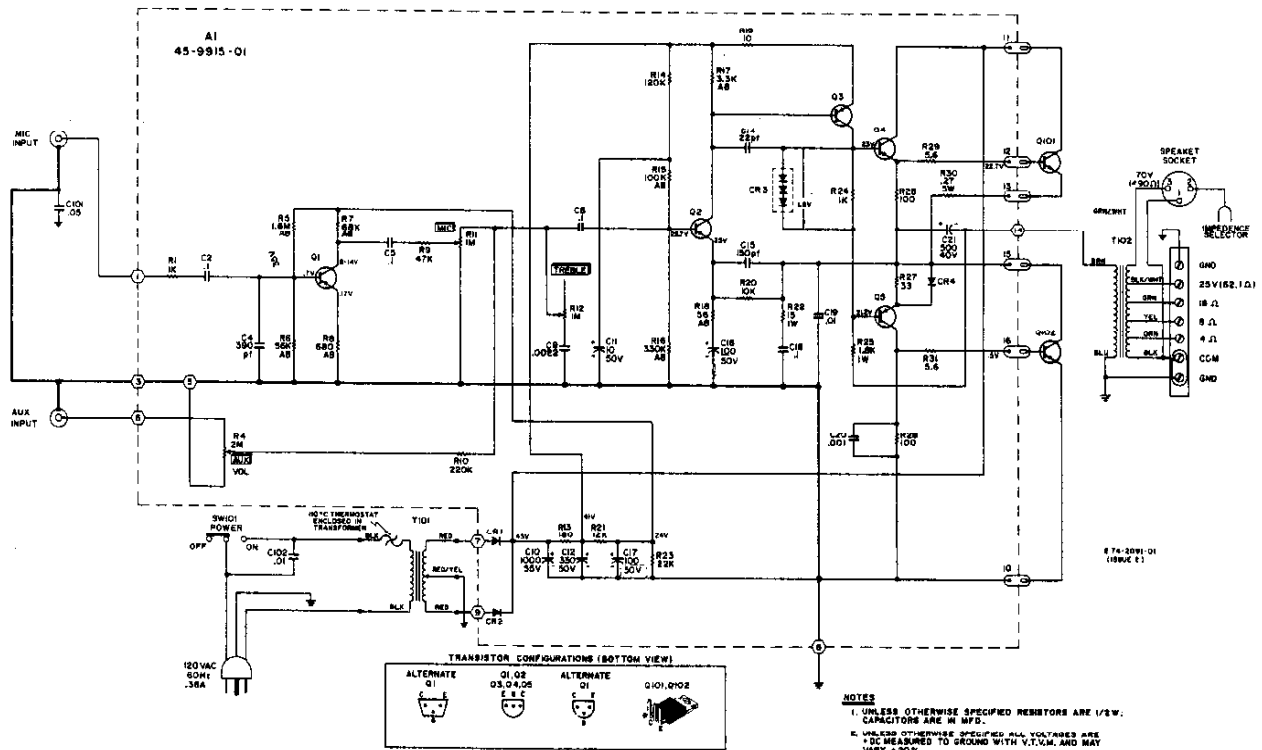

Figure 5 - Model C10 Amplifier, Schematic Diagram