

BOGEN®

COMMUNICATIONS, INC.

SOLID-STATE PUBLIC ADDRESS AMPLIFIERS

C35C, C60C, and C100C

The Bogen Models C35C, C60C, and C100C solid-state public address amplifiers are rated at 35 watts, 60 watts, and 100 watts, respectively, and are UL and CSA listed.

A front-panel selector switch offers a choice of either two low-impedance balanced microphone inputs and one auxiliary input, or one microphone and two auxiliary inputs. A built-in circuit provides microphone precedence over one of the auxiliary channels (AUX 2); muting is achieved by use of a customer-supplied switch. A tuner, cassette player, or tone generator can be connected to the auxiliary inputs. Independent volume controls are provided for each input. Treble and bass controls offer tonal balance.

Balanced or single-ended outputs are provided for standard speaker impedances and 25-volt center-tapped and 70-volt constant-voltage systems. Output jacks provide connections to a tape recorder or an additional (booster) amplifier.

An accessory transformer, Bogen Model WMT-1A, allows input- and output-matching to a telephone line.

The amplifiers operate from a 120VAC, 60Hz source and are equipped with thermal breaker and electrical circuit breaker protection.

INSTALLATION

UNPACKING

The amplifier was carefully checked before leaving the factory. Inspect the shipping container and unit carefully for indication of improper handling. If the unit has been damaged, make an immediate claim to the distributor from whom it was purchased. If the amplifier was shipped directly to you, notify the transportation company without delay and place your claim.

POWER AND GROUNDING

The AC line cord has a three-prong plug which should be plugged into a three-wire grounded 120-volt, 60Hz outlet. **It is important to ground the amplifier.** If a three-wire outlet is not available, use an adapter and connect the grounding pigtail to the screw securing the wall plate; however, if the wall plate is not grounded, connect a wire

from the ground terminal of the amplifier to a suitable earth ground.

INPUT CONNECTIONS

MICROPHONES: Two low-impedance balanced microphones may be connected simultaneously to the screw terminals on the rear panel of the amplifier.

MICROPHONE PRECEDENCE: A built-in circuit provides microphone precedence over the AUX 2 channel. For this function, a customer-supplied normally-open SPST switch must be connected to the AUX 2 MUTE terminals. When the contacts are closed, the microphone will have precedence over the AUX 2 input.

AUXILIARY: The AUX inputs may be used for any signal source having a high-level (.15 - 3V) output, including such Bogen equipment as the TP-50A and TP-100A AM/FM Tuners, CPT-1A Cassette Player/Tuner, and TG-4C Multiple Tone Generator.

OUTPUT CONNECTIONS

SPEAKERS: The amplifier may be used with most conventional speaker systems. Connect one speaker lead to the screw terminal which corresponds to the impedance of the speaker system and the other lead to the COM terminal. If the line is shielded, connect the shield to GND. For balanced output lines, remove the link between the COM and GND output terminals. Class 2 wiring may be used.

TAPE RECORDING: To tape record the amplifier program, connect a patch cord from the TAPE/BOOSTER output jack to the input of the tape recorder. The patch cord should be single-conductor, low-capacity shielded wire, under 35 feet in length, and terminated in a standard RCA phono plug.

BOOSTER AMPLIFIER: To drive a booster amplifier, connect a patch cord from the TAPE/BOOSTER output jack to the input of the booster amplifier. The patch cord should be single-conductor, low-capacity shielded wire, under 35 feet in length, and terminated in a standard RCA phono plug.

TECHNICAL SPECIFICATIONS

Power Output:

C35C — 35W RMS
C60C — 60W RMS
C100C — 100W RMS

Distortion: Less than 2% at RPO, 100Hz to 10kHz

Frequency Response:

C35C, C60C — 100Hz to 10kHz \pm 2dB
C100C — 80Hz to 10kHz \pm 2dB

Hum and Noise:

MIC Input — 60dB below rated output
AUX Input — 70dB below rated output

Input Sensitivity:

MIC Lo-Z Balanced — 300 μ V
AUX — 150mV

Outputs:

C35C — 8, 16 ohms, 25VCT (4.5 ohms), 70V (140 ohms)
C60C — 8, 16 ohms, 25VCT, 70V (82 ohms)
C100C — 4, 16 ohms, 25VCT, 70V (49 ohms)

Input Connections: Two MIC Lo-Z terminals, two AUX Hi-Z jacks; 500/600-ohm line with WMT-1A accessory

Output Connections: Screw-type terminals;

TAPE/BOOSTER jack; provisions for WMT-1A

Controls: MIC 1, MIC 2/AUX 1 (selector-switch), AUX 2, BASS, TREBLE

Tone Control Action:

Treble — \pm 11dB at 10kHz
Bass — \pm 11dB at 100Hz

Power Requirements: 120VAC, 60Hz

C35C — 96 watts
C60C — 170 watts
C100C — 250 watts

Overload Protection: Electrical circuit breaker; 105°C thermostat

Dimensions:

C35C — 14-1/2"W x 3-3/4"H x 10-5/8"D
(37 x 9.6 x 27cm)
C60C, C100C — 14-1/2"W x 3-3/4"H x 11"D
(37 x 9.6 x 28cm)

Shipping Weight:

C35C — 15 lbs. (6.8kg)
C60C — 17 lbs. (7.7kg)
C100C — 22 lbs. (9.9kg)

OPERATION

POWER: The front panel ON/OFF switch applies power to the amplifier and is illuminated when power is ON.

MIC 1, MIC 2: For two microphone inputs, the MIC 2/AUX 1 selector switch should be in the MIC 2 mode. The MIC controls are used to adjust the volume of the microphone inputs. Rotate the controls clockwise to increase volume and counterclockwise to decrease it. Turn the controls to the minimum position if the inputs are not used.

AUX 1, AUX 2: For two auxiliary inputs, the MIC 2/AUX 1 selector switch should be in the AUX 1 mode. The AUX controls are used to adjust the volume of the auxiliary inputs. Rotate the controls clockwise to increase volume and counterclockwise to decrease it. Turn the controls to the minimum position if the inputs are not used.

MICROPHONE PRECEDENCE: Muting of AUX 2 requires a customer-supplied external switch, which must be connected to the AUX 2 MUTE terminals. When the contacts are closed, the microphone will have precedence over the AUX 2 input.

BASS, TREBLE: The BASS and TREBLE controls are used to adjust the tonal balance of the amplifier output. The center position of these controls provides flat frequency response. Counterclockwise rotation of these controls reduces the bass or treble response, while clockwise rotation increases response.

ACCESSORIES

Warning

Removing the amplifier cover presents an electrical shock hazard. Only a qualified technician should install this accessory.

WMT-1A LINE-MATCHING TRANSFORMER: The Bogen Model WMT-1A provides an impedance match between the amplifier and a 0 level, 500/600-ohm line, which may be either a telephone line connected to the switchboard for internal paging or a wired music system. No soldering is required to connect the WMT-1A to the amplifier.

To connect the input from a balanced 500/600-ohm telephone line, remove the amplifier cover and mount the WMT-1A in the mounting holes provided in the chassis. (See Figure 1.) Connect the input line to the three-screw terminal strip on the WMT-1A. Connect the phono plug on the WMT-1A cable to the AUX 1 or AUX 2 jack on the rear of the amplifier. If these jacks are being used for other sound inputs, connect the WMT-1A to one of the MIC inputs; to do this, the WMT-1A jumper must be repositioned, as described in the instruction sheet supplied with the transformer.

To connect the amplifier output to a 500/600-ohm telephone line, remove the amplifier cover and mount the WMT-1A in the mounting holes provided in the chassis.

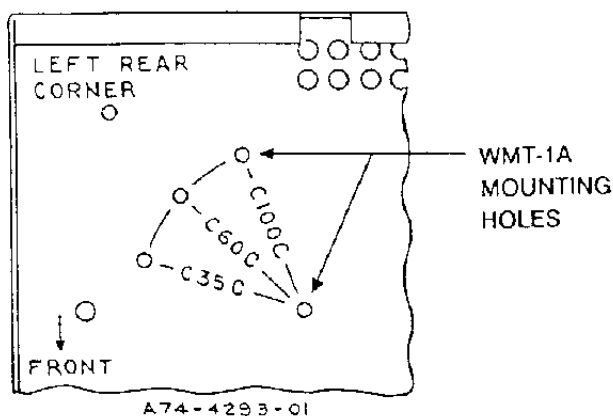

Figure 1 -- Mounting Holes for the WMT-1A

(See Figure 1.) Connect the 500/600-ohm line to the three-screw terminal strip on the WMT-1A. Connect the phono plug on the WMT-1A cable to the WMT-1A (OUTPUT) jack located next to the TAPE/BOOSTER jack on the rear of the amplifier.

MODEL TG-4C MULTIPLE TONE GENERATOR: The Bogen Model TG-4C may be easily connected to an AUX input on the amplifier. It is capable of generating four distinct signals: pulsed tone, slow whoop, repeating chime, and steady tone. Each of these tones may be applied continuously or limited to a double burst (single burst only of the steady tone) for alarm signalling or preannouncement. Both tone level and pitch are adjustable. Signals are triggered by a customer-supplied external device that provides a contact closure.

MODEL RPK-50 RACK PANEL KIT: The Bogen Model RPK-50 consists of two brackets which are designed to mount the C35C, C60C, or C100C amplifier in a standard 19-inch sound rack.

Before affixing the brackets to the amplifier, remove the rubber feet from the bottom of the amplifier. Also, remove the eight screws (four from each side) which secure the amplifier cover. **Do not remove the cover.** Align three of the holes in each mounting bracket with the corresponding holes in the cover. (See Figure 2.) Secure the brackets to the cover with the six 3/8" screws provided in the kit. Each bracket has two elongated holes (on 3" centers) for fastening to the sound rack.

Bracket dimensions are 3-1/2" H x 2-3/16" W x 2-1/2" D (8.9 x 5.6 x 6.4 cm) each. They are fabricated from cold-rolled steel and have a black finish.

MAINTENANCE

Caution

There are no user-replaceable parts within the unit. To avoid an electric shock hazard, have all internal servicing done by qualified service personnel only.

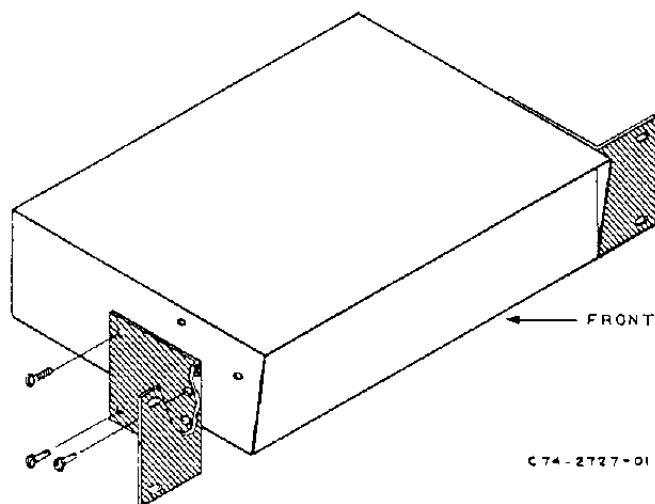

Figure 2 -- Installing Rack-Mounting Brackets

CIRCUIT BREAKER

If the circuit breaker opens, the AC power lamp will go out and the amplifier will have no output. Set the AC power switch to OFF and momentarily depress the red button on the circuit breaker to reset it. Return the AC power switch to ON. If the breaker trips again, do not attempt to reset it, but have the trouble investigated by a qualified technician.

THERMAL BREAKER

If the thermal breaker opens, there will be no audio output but the AC power lamp will remain ON. Wait approximately two minutes for the breaker to reset. If the breaker resets and then opens again, investigate the cause of the temperature overload. This may be due to improper connections at the output terminals or to excessive environmental heat with inadequate ventilation. The thermal breaker will open when the temperature at the output transistor heat sink reaches 105°C.

Caution

When soldering leads, use a heat sink (such as a small alligator clip) between the transistor and the source of heat.

PRINTED CIRCUIT BOARD

All components on top of the printed circuit board are easily accessible with the cover removed. The underside of the PC board can be exposed for repair or troubleshooting without disconnecting any wires. To do this, proceed as follows:

1. Remove all knobs and mounting nuts from the five control shafts.
2. Three nylon standoffs are used to support the rear of the PC board. Progressively disengage the three standoffs at the rear by raising the edge of the board with one finger, while depressing the locking tab on the standoff with a screwdriver blade.

3. Push the board toward the rear of the chassis until the shafts clear the holes in the front panel. The front of the board may now be tilted upward to expose the underside connections.

REPLACING TRANSISTORS

When replacing transistors, use those made by the manufacturer specified in the Replacement Parts list. Transistors from other suppliers may not be satisfactory.

When replacing the driver transistors, press a small screwdriver blade into the side of the U-clip heat sink to spread the jaws of the clip. Draw the clip and screwdriver off the metal tab on the driver transistor. Reverse the procedure to install the clip on the replacement transistor. Since the U-clip heat sink is a spring clip, avoid spreading the jaws too wide. Where driver transistors have a finned clip or heat sink, remove the heat sink from the original transistor and replace by pushing down onto the new transistor. This is accomplished best by installing the heat sink before soldering the transistor into the circuit board.

When replacing the output transistors, clean all foreign matter from the heat sink, insulator, and transistor. Brush on a light coating of silicon compound to completely cover both surfaces of the insulator (Part No. 16-9278-01). Place the insulator between the heat sink and the replacement transistor. Use the original transistor mounting hardware to mount the replacement transistor. Snap the transistor cover over the heat sink where used.

Most components are standard parts available through reputable parts suppliers. The parts listed here may be obtained from Bogen distributors, service agencies, or directly from the factory. When ordering a part, specify the part number, as listed, the model of the unit and give the series designation, which is a letter followed by numbers, printed on the chassis. For parts on the circuit board, also give the component board assembly number, which begins with "45."

REPLACEMENT PARTS

Schem.

Ref	Part No.	Description
		<i>PC Board</i>
	45-7355-05	PC Board Assembly
C1,4,20	79-126-031	Cap., Elect., 10 μ F, 16V
C3,6	79-126-035	Cap., Elect., 100 μ F, 16V
C9	79-126-054	Cap., Elect., 2.2 μ F, 50V
C11,16	79-126-053	Cap., Elect., 100 μ F, 35V
C12-14	79-126-040	Cap., Elect., 10 μ F, 25V
C15	79-126-064	Cap., Elect., 330 μ F, 50V
C16,35	79-008-045	Cap., Elect., 330 μ F, 35V
C18	79-126-046	Cap., Elect., 22 μ F, 35V
C25	79-126-076	Cap., Elect., 470 μ F, 63V
C28	79-126-058	Cap., Elect., 10 μ F, 50V
C30	79-126-062	Cap., Elect., 100 μ F, 50V

Schem. Ref.	Part No.	Description
CR 3,4	96-5795-01	Diode, IN4935
CR2	96-5333-01	Diode, 400prv @ 1A
IC1	96-5733-01	IC, LM387A
Q1	96-5290-01	Transistor, MPS-A05/2SC815Y
Q2,6	96-5213-01	Transistor, 2N5089/KSC945L
Q3,5	96-5283-01	Transistor, MPS-A55/KSA539Y
Q4	96-5298-01	Transistor, SPS1910/KSC945L
Q7	96-5357-01	Transistor, 2SD389(P)/2SD313D/TIP31A
Q8	96-5356-01	Transistor, 2SB512(P)/2SB507D/TIP32A
Q9	96-5214-01	SCR, 2N5060
R7	77-001-830	Control, 1 megohm, Audio
R15,17,29,32	77-001-810	Control, 100 kilohms, Audio
R51,53	76-107-096	Resistor, .82 ohm, 2W
R45	75-173-132	Resistor 1.3K ohm, 1/4W Chassis
C102	78-200-116	Cap., Cer. Disc., .01 μ F, 1400V
C103	79-509-051	Cap., Elect., 1500 μ F, 75V (C35C)
	79-509-052	Cap., Elect., 2000 μ F, 75V (C60C)
	79-509-053	Cap., Elect., 3000 μ F, 75V (C100C)
C105	79-119-015	Cap., Elect., 3300 μ F, 63V
CB101	94-0023-03	Ckt. Bkr., 0.5A HOLD (C35C)
	94-0023-05	Ckt. Bkr., 1.0A HOLD (C60C)
	94-0023-08	Ckt. Bkr., 1.5A HOLD (C100C)
CB102	94-0014-07	Thermal Breaker (105°C)
CR101-104	96-5241-01	Diode, 300prv @ 3A
Q101,102	96-5890-01	Transistor, MOTOROLA, MJ15015 (C35C, C60C)
Q101-104	96-5890-01	Transistor, MOTOROLA, MJ15015 (C100C)
R101,102	76-116-003	Resistor, .27, 7W (C35C, C60C)
R101-104	76-116-003	Resistor, .27, 7W (C100C)
R105	75-742-101	Resistor, 100 ohms, 7W
SW101	81-009-035	Ltd. Rocker Switch, 10A, SPST
SW102	81-003-065	Slide Switch
T101	83-805-010	Power Transformer (C35C)
	83-809-000	Power Transformer (C60C)
	83-814-010	Power Transformer (C100C)
T102	83-428-010	Output Transformer (C35C)
	83-429-010	Output Transformer (C60C)
	83-430-010	Output Transformer (C100C)
CR105	96-5889-01	Tranzorb, 1.5KE 24C
	03-0686-01	Knob
	14-9088-01	Foot

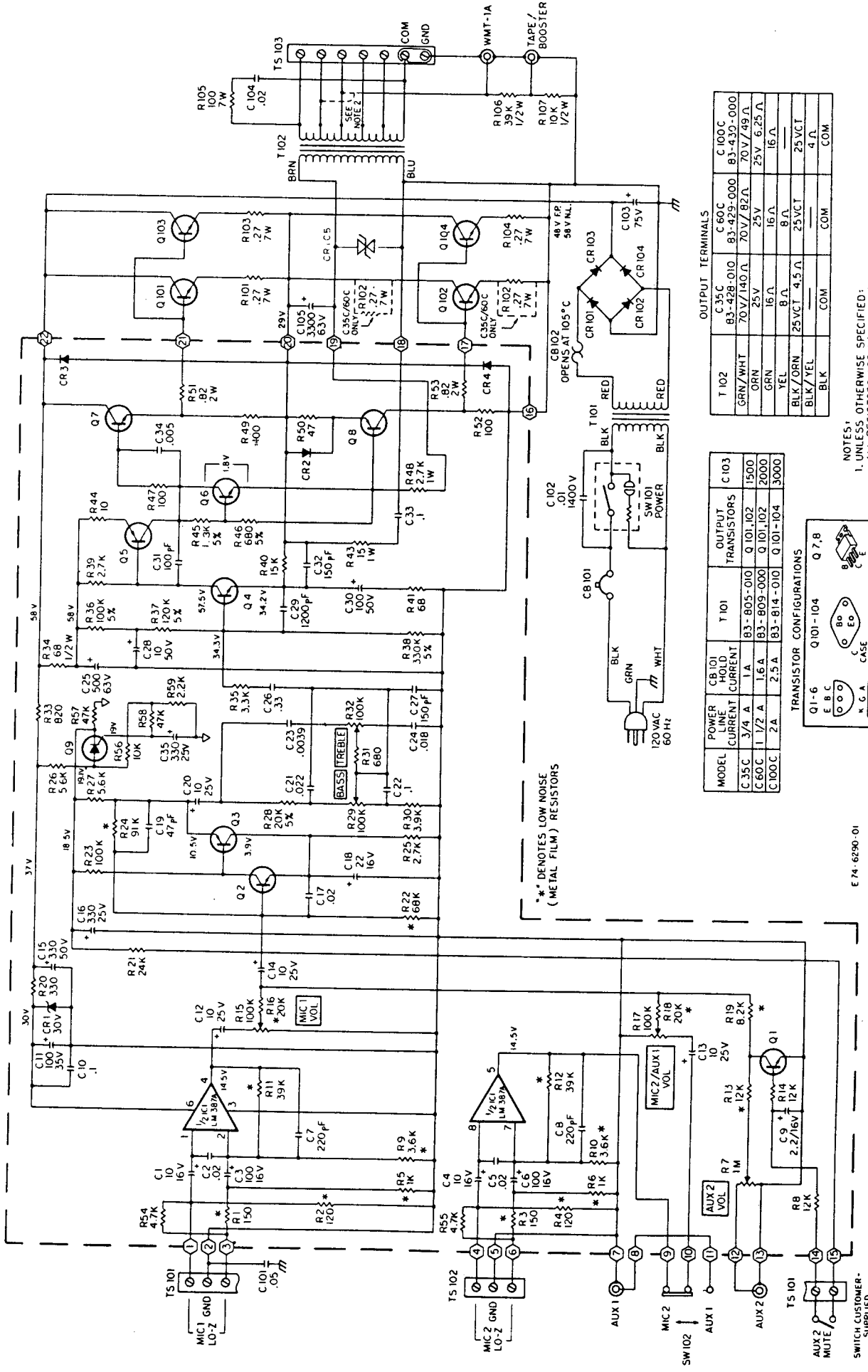

OUTPUT TERMINALS

T 102	C 35C	C 60C	C 100C
GRN/WHT	83-428-010	83-429-000	83-430-000
ORN	70V/140Ω	70V/82Ω	70V/49Ω
GRN	25V	25V	25V
YEL	16Ω	16Ω	16Ω
BLK/ORN	25VCT 4.5Ω	25VCT	25VCT
BLK/YEL	COM	COM	COM
BLK	COM	COM	COM

MODEL	POWER LINE CURRENT	CB 101 CURRENT	T 101 TRANSISTORS	C 103 OUTPUT TRANSISTORS
C 35C	3/4 A	1 A	83-805-010	Q 101, 102
C 60C	1 1/2 A	1.6 A	83-809-000	Q 101, 102
C 100C	2 A	2.5 A	83-814-010	Q 101-104

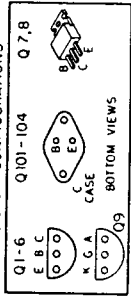

- NOTES:
- UNLESS OTHERWISE SPECIFIED: ALL RESISTORS ARE 1/4W, ±10%; CAPACITORS ARE IN MFD. VOLTAGES ARE DC, ±10% AS MEASURED WITH A DVM.
 - WIRE CONNECTION TO ORANGE OUTPUT TRANSFORMER LEAD ON ALL AMPLIFIERS.

* DENOTES LOW NOISE (METAL FILM) RESISTORS

E 74-6290-01

Figure 3 -- Schematic Diagram, Models C35C, C60C, and C100C