

# BOGEN®

## *The Challenger Series*



### MODEL CHB 100

100 WATT PUBLIC ADDRESS AMPLIFIER

LEAR SIEGLER, INC.



BOGEN DIVISION  
P.O. BOX 500  
PARAMUS, N. J. 07652

## **INSTALLATION AND OPERATING MANUAL**

READ THOROUGHLY BEFORE OPERATING EQUIPMENT



# INTRODUCTION

The model CHB100 is a general purpose 100-watt public address amplifier. It features five separate inputs with facilities for selection and mixing of up to three inputs. A master volume control provides control of overall gain. Separate Bass and Treble controls are incorpor-

ated for adjusting tonal balance.

Outputs are provided for all standard speaker impedances and for operation with 25-volt and 70-volt long line speaker systems. Two quick disconnect type plugs permit quick connection of speaker system.

## TECHNICAL SPECIFICATIONS

USEABLE POWER: 100 watts at 5% distortion

FREQUENCY RESPONSE: 20 to 20,000 Hz,  $\pm 2$ db

HUM & NOISE:

MIC Input: 65db below rated power

AUX Input: 80db below rated power

GAIN:

MIC Input: 125db

AUX Input: 100db

MAG Phono Input: 115db

SENSITIVITY:

MIC Input: 4 millivolts

AUX Input: 0.2 volts

MAG Phono Input: 12 millivolts

INPUTS: 2 microphone (high impedance), 1 magnetic phono and 2 auxiliary (high impedance, high level)

OUTPUTS: 4, 8 and 16 ohm speaker, 25-volt (8

ohms) and 70-volt (80 ohms) line, 2 quick disconnect sockets and connectors provided in addition to screw terminals.

tone CONTROL ACTION:

TREBLE: +12 to -15db at 10 kHz

BASS: +14 to -9 db at 50 Hz

CONTROLS: Microphone No. 1 Volume, Input 2 Volume, Input 2 Selector Switch, Aux1/2 Volume, Master Volume, Bass, Treble, Power and Balance Adjustment.

TUBES: Total of 7 (6EU7, 11AX7, 6C4, 4-7868) plus 3 silicon rectifiers.

POWER CONSUMPTION: 300 watts, 105-125 volts, 50 to 60 cycles, AC

DIMENSIONS: 15-3/4" wide, 6-3/4" high, 10" deep

WEIGHT: 26 lbs.

## ACCESSORIES



### MODEL SR2 REMOTE CONTROLLER

Permits the user to control the gain of the Mic 1 and Mic 2/Mag Phono inputs from distances up to 2,000 feet from amplifier without sacrificing power or signal quality. Allows you to mix and fade the two signal inputs.

### MODEL LK-5 LOCKING PLATE

Model LK-5 Locking Plate is designed to prevent unauthorized tampering with controls of amplifier. Comes complete with instructions and a set of two keys. As a safety factor, key cannot be removed when lock is in open position.

### MODEL LPC-4 PHONO PLAYER TOP

Model LPC-4 is a complete 4-speed phono-player designed to be mounted directly on top of of the amplifier. The unit comes complete with

all necessary hardware. It can be easily installed and connected to amplifier with only a screwdriver. It includes a 4-speed vibration-isolated turntable and tone arm housing a dual-styli turnover cartridge.

### MODEL WMT-1 LINE MATCHING TRANSFORMER

Used with this amplifier for distribution of background music directly from a leased telephone line, wired music systems or any 0 level 500/600 ohm line. Provides an impedance match between 500/600 ohm balanced line and high impedance input of amplifier. The WMT-1 has a 3-screw terminal strip for input connections and output. No wiring or soldering required for making normal connections between amplifier and input or output lines. Slight modification permits WMT-1 connection to MIC input of amplifier.



# INSTALLATION

## UNPACKING

Inspect shipping container and unit for indications of improper handling. The unit was carefully checked before leaving factory. If unit has been damaged, make an immediate claim to dealer or distributor from whom it was purchased. If unit was shipped to you, notify transportation company without delay and place your claim.

## CONNECTIONS BETWEEN COMPONENTS

Use single conductor, low-capacity shielded wire for connecting the record player, tape recorder, and other components (except speakers) to amplifier. Keep leads under 35 feet in length.

Speakers may be connected with standard flexible line cord ("zip cord") and up to 100 feet of cable may be used without appreciable loss.

Make certain that all audio cables are kept away from speaker cables, power cables, and power transformers, and that speaker cables are kept away from power cables.

## POWER AND GROUNDING

The amplifier is furnished with an ac line cord terminated in a three-prong plug. Plug the line cord into a three-wire grounded outlet providing a nominal 120-volt, 50-60 cycle power source. This will ground the amplifier as well as supply power to it.

It is advisable to ground the amplifier. Therefore, if a three-wire outlet is not available, an adapter such as Leviton No. 5017 should be used to convert a standard two-wire outlet for use with three-wire plugs. The adapter is provided with a grounding pigtail which should be connected to the screw holding the wall plate to the receptacle, as shown in figure 2

### NOTE

In some areas, the wall plate screw is not grounded. In this case it will be necessary to connect a grounding wire between the GND terminal on the rear chassis of the amplifier and a water or steam pipe.

## INPUT CONNECTIONS

### MICROPHONE

Two microphones may be connected to the amplifier simultaneously. Connect one to the MIC 1 receptacle and the second to the MIC 2 receptacle (see figure 1). When using the MIC 2 Input move the INPUT 2 SELECTOR switch to the MIC 2 position.

The microphones should be of the high impedance type (ceramic, crystal, etc.). Use a Bogen Part No. 85-0130-01 connector (or equivalent), and single-conductor shielded cable under 35 feet in length for connection of microphone.

### PHONO

Phonographs employing either ceramic, crystal or magnetic cartridges may be connected to the amplifier. For phonographs using a magnetic cartridge, connect the input cable to the MAG receptacle and move the the INPUT 2 SELECTOR switch to the MAG position.

Phonographs employing a ceramic or crystal type cartridge may be connected to either the AUX 1 or AUX 2 receptacles. Use single-conductor shielded cable terminated in a standard single-prong phono plug. It is recommended that a separate ground wire be connected between the

phono player base and the amplifier GND terminal to minimize hum pick-up. This is not required when using the Bogen model LPC-4 phono player top.

### WMT-1 ACCESSORY

To connect the input from a 500/600-ohm line, mount the WMT-1 transformer on the WMT-1 mounting holes on the rear chassis. Connect the 500/600-ohm input to the three-screw terminal board on the accessory. Connect the phono plug on the WMT-1 to the AUX 1 or AUX 2 input of the amplifier. If another sound source has been plugged into the AUX input, the WMT-1 may be connected to the MIC input of the amplifier. However the WMT-1 wiring must first be modified, as described in the instruction sheet furnished with the accessory.

### AUXILIARY

The AUX inputs may be used for sources other than a phonograph. Any signal source having a high level, high impedance output may be connected to these inputs. This includes virtually all tuners and tape recorders having preamplifiers. An input signal level of approximately 0.30 volt is required to obtain full output from the amplifier.

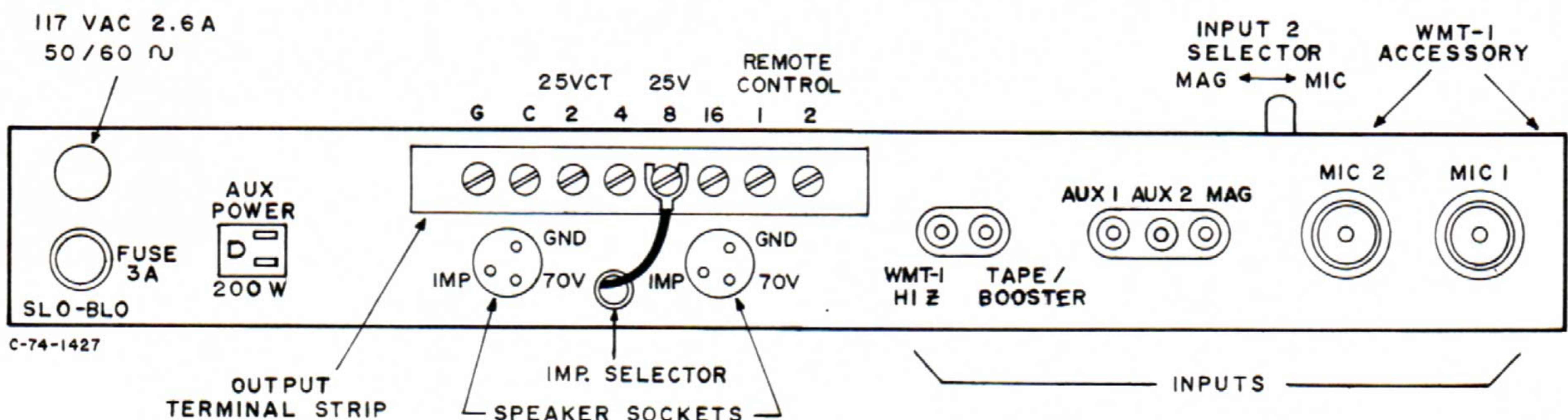

Figure 1 - Rear view of amplifier.



## OUTPUT CONNECTIONS

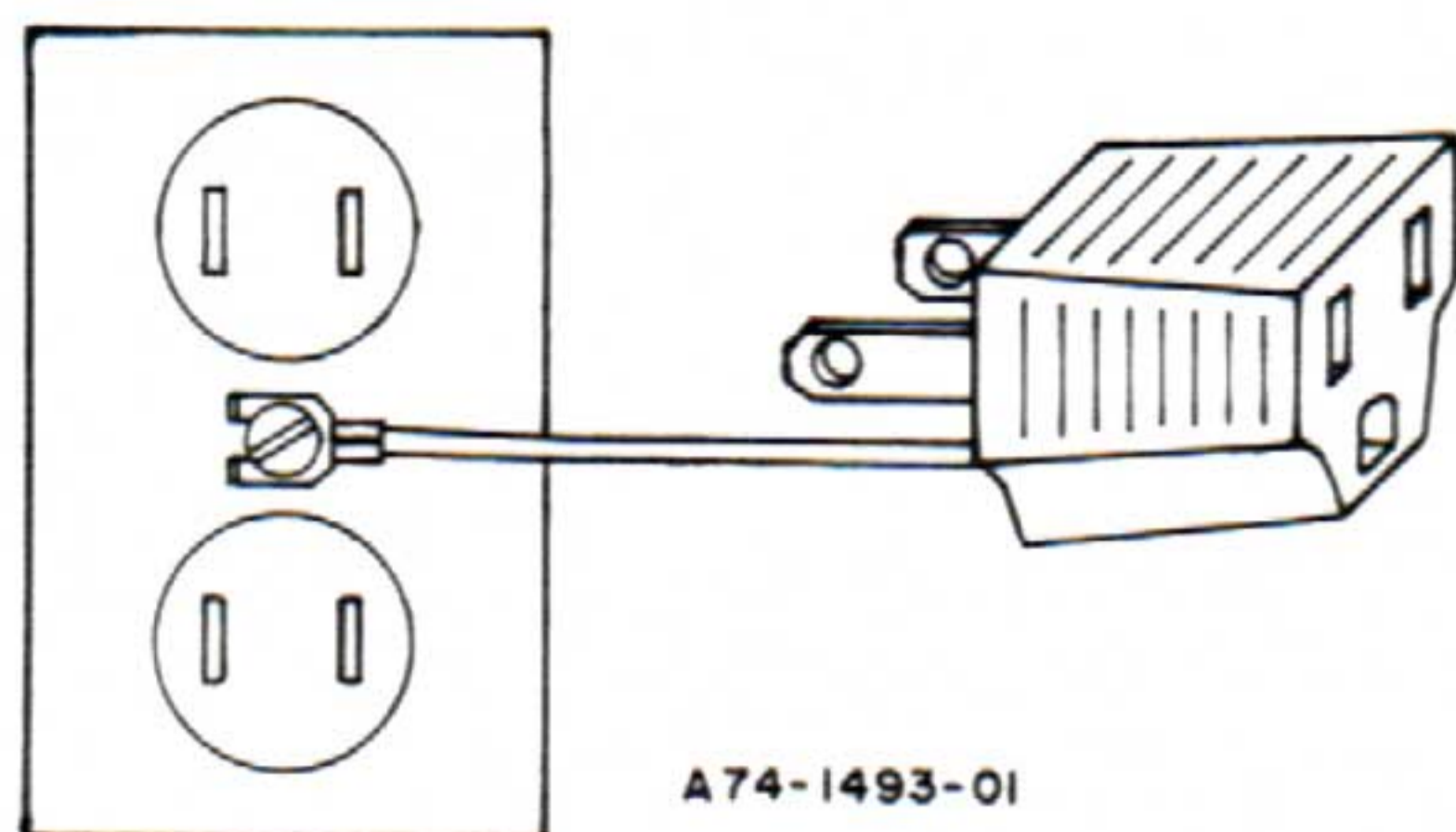

Figure 2 — Grounding line cord adapter.

### TAPE OR BOOSTER AMPLIFIER

To drive a booster amplifier or tape recorder connect a patch cord (with a standard phono plug) from the TAPE/BOOSTER output jack to the input of the booster amplifier or tape recorder.

### WMT 1 TRANSFORMER

To feed a 500/600 ohm line connect the WMT-1 phono plug to the WMT-1 HI Z output jack of the amplifier. Connect the 500/600 line to the terminals on the WMT-1. Holes are provided on the chassis for mounting the WMT-1.

### SPEAKERS

The amplifier may be used in conjunction with speaker systems rated at 4, 8 and 16 ohms and 25 and 70 volt constant voltage speaker systems. For detailed information on installation of multiple speaker systems refer to the "Speaker Installation" bulletin (No. 54-5001-02) included with this unit.

In permanent installations, where speakers will remain connected to the amplifier permanently, connect the speaker system directly to the Speaker Output terminals. Connect one lead to the COM terminal and the other to the terminal corresponding to the speaker system's impedance. In systems that are moved continually, use the speaker sockets on the rear panel and the speaker plugs furnished with the amplifier for making connections. This will provide

quick disconnect of speaker system. Secure the Impedance Selector lead to the appropriate speaker impedance terminal. In systems where the 70-volt output is used, this is not required.

Wire to the plug as follows: For 70 volt operation — connect leads to pins 1 and 3. For standard impedance and 25 volt systems — connect leads to pins 1 and 2.

In some cases, it may be desirable to use both the speaker output terminals strip and the speaker socket for speaker connections. The speaker system connected to the speaker socket need not have the same impedance as the speaker system connected to the terminals. However, correct impedance matching between the amplifier output and all speaker systems is essential to obtain maximum power.

### AUXILIARY POWER

The auxiliary power receptacle located on the rear chassis can supply power to associated equipment such as a phonograph or tuner. Be sure that the auxiliary component plugged in here does not draw more than 200 watts. The power switch on the front panel controls this receptacle and can be used as the main power switch for the auxiliary unit.

The auxiliary power receptacle is a three-wire grounded outlet. Hence, any associated equipment connected to it with a three-prong line cord will be grounded, providing the amplifier has been properly grounded as described above.

#### CAUTION

Both the amplifier power switch and the phono on-off switch must be used in turning off a record player connected to the auxiliary receptacle. Flats may develop on the idler wheel of the phonograph, if only the amplifier power switch is used to stop the record player.

## CONTROL FUNCTIONS

### MICROPHONE 1

This control adjusts the volume level of the microphone 1 input. Rotate the control clockwise (to higher numbers) to increase volume. Set the control to the minimum position (0) when the microphone input is not used.

### INPUT 2

This control adjusts the volume level of either the microphone 2 or mag phono input, depending on the input selected with the INPUT 2 SELECTOR switch on the chassis top rear. Rotate the control clockwise (to higher numbers) to increase volume. Set the control to the minimum position (0) when the microphone input is not used.

### AUXILIARY

This control serves a two-fold purpose. It selects either of the two auxiliary inputs and it controls the volume of the selected auxiliary input. Operate the controls as follows: To select the Aux 1 input rotate the control counterclockwise past the center position; rotating the control more counterclockwise increases the Aux 1 volume. To select the Aux 2 input rotate the control clockwise past the center position; rotate the control more clockwise to increase the Aux 2 volume. If the auxiliary input is not to be used, set the control to the mid position (off).

The control can be also used as a "fader" control when both auxiliary inputs are used. Hence, it is possible to gradually and smoothly reduce the level of one input and then increase the other when changing inputs. The effect is one of fading from one to the other.



## MASTER

After first adjusting the MIC and AUX input volume controls to mix the inputs as desired, use this control to control the overall volume of the output signal.

## RESET MARKER

Each volume control has a red reset marker on the skirt of the knob. This marker is used to log a particular setting.

Make a "dry-run" or rehearsal to adjust volume controls to desired levels. Slide reset markers to coincide with midpoint mark on front panel. Knobs can now be set to zero or any other point allowing instant resetting to indicated settings.

## BASS & TREBLE

These controls are used to adjust the tonal balance of the amplifier output. The center positions of the controls, provide full frequency response and are generally used when program sources and speaker systems are of highest quality.

Rotation of the proper control in the counter-

clockwise direction reduces (cuts) treble or bass response of the amplifier. Clockwise rotation of controls increases (boosts) treble or bass response.

The Treble control will remove high frequency noise (e.g. record scratch), compensate for speakers having poor low frequency response (e.g. paging or outdoor type speakers). The Bass control should be used to remove low frequency noise (e.g. phono rumble or hum) and for compensating for speakers having poor high frequency response. In situations where acoustic feedback (howling) is likely, rotate both controls counterclockwise; this reduces the feedback effect and permits higher volume levels than would otherwise be possible.

## POWER

This slide type switch turns the amplifier on and off.

## INPUT 2 SELECTOR

This control is located on top of the chassis close to the rear edge (refer to figure 1). It is used to select either Mic 2 or Mag Phono for the input 2 signal source.

# INSTALLATION & OPERATING HINTS

## FEEDBACK

If speakers are located too close to microphone, acoustic feedback (squealing or howling) may result. In this case, adjust the volume and/or Treble and Bass controls to the point where feedback is eliminated. In addition, move the speakers to increase the distance between the speakers and microphone.

## HUM

Hum type interference can occur if the connections between the signal sources and amplifier

are incorrect or defective. Recheck all connections (check for continuity) in cases where hum occurs. Try reversing the amplifier power plug, and those of units used in system (e.g. phono player) in wall outlet. Check for broken wires, shields and poor connector contacts. Keep input cables away from speaker cables. Keep speaker cables away from transformers and AC power lines. In the case of a phono player, it may be necessary to connect a separate ground wire from the chassis of the phono player to the GND on the rear of the amplifier.

# SERVICE

## BALANCING OUTPUT TUBES

If any of the four power output tubes are changed, the Balance Adjustment must be checked. This control is located on the underside of the chassis, adjacent to the output tubes and is a screwdriver type adjustment. Adjust the control for minimum hum with all inputs disconnected and all volume controls set at minimum.

## TUBE REPLACEMENT

Tubes should be tested at least once every six months to insure optimum high-fidelity performance. To avoid possibility of shock, do not remove chassis when replacing tubes.

## FUSE

A slow-blow type fuse is located in a holder at the rear of the amplifier. To replace fuse, press spring loaded cap slightly inward, rotate counterclockwise, and withdraw cap and fuse. Use only a fuse of the same rating for replacement. If a second fuse blows, do not make any further attempt to operate unit. Consult a Bogen representative or other competent technician for inspection of unit.

## BOGEN SERVICE

We are interested in your Bogen Ampli-

fier unit for as long as you have it. If trouble ever develops with your unit, please do not hesitate to ask our advice or assistance. Information can be obtained by writing to Service Department, Bogen Division, P.O. Box 500, Paramus, New Jersey 07652.

When communicating with us give the model number and serial number of your unit. Completely describe the difficulty encountered. Describe the effects each operating control has upon the symptoms of trouble. Include details on electrical connections to associated equipment and list such equipment.

When we receive this information we will send you service information if the trouble appears to be simple (e.g., bad vacuum tube, incorrect connections). If trouble requires servicing, we shall send you the name and address of the nearest Bogen authorized service agency to which you can send your unit for repair.

When shipping your unit, pack instrument well using the original shipping carton and filler material to prevent damage in transit. Send unit, fully insured and prepaid, via railway express. Do not ship via parcel post unless so instructed. The unit will be promptly repaired and returned to you via express collect.





**NOTES**  
 UNLESS OTHERWISE SPECIFIED  
 1. ALL RESISTORS ARE 1/2 WATT ±10%  
 2. ALL CAPACITORS IN WHOLE NUMBERS ARE IN MMFD.; THOSE IN DECIMAL VALUES ARE IN MFD.  
 3. ALL VOLTAGES ARE DC, MEASURED WITH A 20,000 Ω / VOLT METER AND MAY VARY ± 20%

**VOLTAGE CHART**  
 VOLTAGES ARE DC, UNLESS OTHERWISE SPECIFIED, MEASURED WITH RESPECT TO GROUND WITH A VTVM, AND MAY VARY ± 20%

NO	TYPE	1	2	3	4	5	6	7	8	9
V1	6EU7	3.2AC	3.2AC	0	0	-5	50	50	-5	0
V2	I2AX7	1.25	0	6.5	3.2AC	3.2AC	1.25	0	0.5	3.2AC
V3	6C4	250	0	3.2AC	3.2AC	250	100	120		
V4	7868	450	-22	1	3.2AC	3.2AC	-22	450	0	460
V5	7868	450	-22	1	3.2AC	3.2AC	-22	450	0	460
V6	7868	450	-22	1	3.2AC	3.2AC	-22	450	0	460
V7	7868	450	-22	1	3.2AC	3.2AC	-22	450	0	460

**REPLACEMENT PARTS**

PART NO	DESCRIPTION
03-0594-01	KNOB 0-10
03-0595-01	KNOB 0-5-0
02-9029-01	RESET IND

Figure 3 - Schematic Diagram CHB100