

BOGEN®

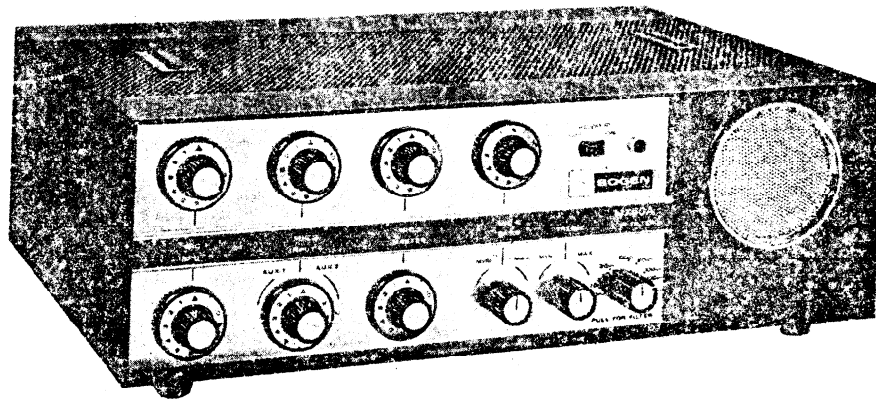

MODEL MX60A

60 WATT
PROFESSIONAL AMPLIFIER

LEAR SIEGLER, INC.



BOGEN DIVISION
P.O. BOX 500
PARAMUS, N. J. 07652

INSTALLATION AND OPERATING MANUAL

READ THOROUGHLY BEFORE OPERATING EQUIPMENT

DESCRIPTION

The Bogen Model MX60A is a 60-watt professional quality, self-contained preamp-amplifier-mixer. It is designed for use in theatres, radio stations, recording studios, and quality public address installations.

The amplifier provides five microphone inputs, four of which may be used with either high or low impedance mikes. The fifth input will accommodate either a high-impedance microphone or a magnetic phono/tape head input. Input 6 will accommodate two high-level, high-impedance auxiliary inputs, such as a ceramic phono cartridge or tape recorder. A front panel control permits fading between these inputs. All six inputs may be mixed and faded, and the volume of each may be controlled individually or simultaneously with the master volume control. There is a bridging input which accepts inputs from a high-level source with its own level control. The bridging input may be mixed with the other inputs, but it cannot be individually controlled at the amplifier.

Each of the five microphone input channels is equipped with a music-speech filter switch, which may

be set to provide a fixed, low-frequency attenuation for the particular input. This selective filtering helps to overcome poor room acoustics and increases speech intelligibility by improving individual microphone response.

All input channels, except the bridging input, may be provided with remote volume control or microphone precedence control. This is accomplished by using Bogen accessories SR-2, SR-4 and RVC-2 remote volume controls and the LVP-1 limiter.

In addition to standard 4, 8 and 16-ohm output speaker taps, constant voltage balanced 25-volt and 70-volt lines are available at the output to simplify line matching. The output may also be fed to a telephone line by connecting the WMT-1 as a bridging accessory across the 25-volt line.

The MX60A amplifier may be paralleled with another MX60A amplifier to double the number of input channels and increase the output power.

TECHNICAL SPECIFICATIONS

POWER OUTPUT: 60 watts at less than 2% distortion.

PEAK POWER: 85 watts.

FREQUENCY RESPONSE: $\pm 1\frac{1}{2}$ db, 10 Hz to 38 KHz.

POWER RESPONSE: ± 1 db of 60 watts from 21 Hz to 30 KHz at 5% distortion.

HUM AND NOISE: Below rated output,
AUX 80 db, MIC 70 db, MAG 55 db.

GAIN: Based on 500 Ω input impedance,
AUX + 90 db, MIC + 120 db, MAG + 125 db.

SENSITIVITY: AUX 0.15 V, MIC 4 mv, MAG 2 mv.

BRIDGING INPUT SENSITIVITY: 5.8 V

BRIDGING OUTPUT: 0.6 V (across 1 Meg Ω)

DRIVER OUTPUT: 2 V

C.P. AND DRIVER OUTPUTS: cathode paralleling and booster amplifier outputs for use when extra power is required.

DAMPING FACTOR: Better than 5 to 1.

TONE CONTROL ACTION:

Treble: - 14 db to +10.5 db at 10 KHz

Bass: - 9 db to +14.5 db at 50 Hz

REGULATION: 2 db

INPUTS: (Total of 10) 4 MIC (convert to low impedance with TM50, TM200, TM500 transformer). Input 5 will accommodate 1 MIC (high impedance) or 1 MAG phono (or tape head). Input 6 will accommodate 2 AUX high-level, high-impedance inputs. 1 bridging input for high impedance or 600 Ω balanced telephone line with optional WMT-1 transformer.

NOTE: 4 MICS and the chosen input of inputs 5 and 6 may be simultaneously mixed and faded.

CONTROLS: 4 individual MIC volume (each with pull speech filter switch). 1 input 5 volume (with pull speech filter switch). 1 input 6, AUX 1, AUX 2 volume (fader type). - master volume - bass - treble - calibrated low frequency filter (variable 10 - to 200 cps) - with pull switch, (in-filter off) (out-filter on). - power switch - top of chassis 4 individual selector switches, MIC 1 thru MIC 4 (high or low impedance), rear panel input 5 switch (to select MIC 5 high impedance or MAG/tape - limiter sensitivity (screw driver adjust)).

OUTPUTS: 4, 8 and 16 Ω balanced, 25V balanced (10 Ω), 70V balanced (82 Ω)

POWER CONSUMPTION: 180 watts.

TUBES AND RECTIFIERS: Two 8417, three 7247, three 12AX7A, five silicon diodes.

DIMENSIONS: 17" W, 12" D, 5-3/8" H.

WEIGHT: 37 lbs.

ACCESSORIES

MIC INPUT TRANSFORMERS

Bogen Models TM50, TM200 and TM500 transformers constitute a group of plug-in type zero-level line-matching transformers. These transformers are designed to match the input impedance of the amplifier to the low-impedance output of the microphone. TM50 is designed for 50 ohms, TM200 for 200 ohms and the TM500 for 500 ohms.

WMT-1 LINE MATCHING TRANSFORMER

The Bogen WMT-1 line input/line output matching transformer is an accessory which has been designed especially for matching either inputs from or outputs to a 500/600 ohm line. As an input matching transformer it may be used with the Bogen amplifier for distributing background music which has been transmitted over leased telephone lines. The accessory also functions as an output matching transformer in feeding special program material over a 500/600 ohm telephone line for transmission to a local broadcast studio.

LVP-1 LIMITER

The Bogen Model LVP-1 is a plug-in accessory which permits the user to provide remote standby when used with a customer supplied switch and the Bogen amplifier. The LVP-1 may also be used as a remote volume control in conjunction with the Model RVC-2 remote volume control.

RVC-2 REMOTE VOLUME CONTROL

The Bogen Model RVC-2 accessory permits the amplifier to provide remote control of the MASTER and AUX volume. The RVC-2 is used in conjunction with the LVP-1 accessory.

SR-2 AND SR-4 REMOTE VOLUME CONTROLS

The SR-2 permits the user to control the volume as well as mix and fade two microphone inputs from a distance of up to 2000 feet without loss of power or signal quality. The model SR-4 will similarly control four microphone inputs.

MMS-1 AND MSK-1 MONITOR SPEAKERS

The Bogen Model MMS-1 Monitor Panel consists of a monitor speaker, meter and level control, assembled on a panel. The unit mounts on the right-hand section of the amplifier front panel in place of the existing dummy panel. It provides both a visual and aural check of the output of the amplifier.

The Model MSK-1 Monitor Kit consists of a monitor speaker, a level control, and a five-pin plug. These components are mounted on the existing monitor panel, and provide a means of monitoring the output level of the amplifier.

LK-6 CONTROL GUARD LOCKING PLATE

Bogen Model LK-6 control guard locking plate is designed to prevent unauthorized tampering with the controls of amplifier. It comes complete with two sets of keys. The key cannot be removed when the lock is in open position.

MODEL LPC-4 PHONO PLAYER TOP

Model LPC-4 is a complete four-speed phono-player designed to be mounted directed on top of the amplifier. The unit comes complete with all necessary hardware. It can be easily installed and connected to amplifier with only a screwdriver. It includes a four-speed vibration-isolated turntable and tone arm housing a dual-styli turnover cartridge.

INSTALLATION

UNPACKING

Inspect shipping container and unit for indications of improper handling. The unit was carefully checked before leaving factory. If unit has been damaged, make an immediate claim to dealer or distributor from whom it was purchased. If unit was shipped to you, notify transportation company without delay and place your claim.

CONNECTIONS BETWEEN COMPONENTS

Use single conductor, low-capacity shielded wire for connecting the record player, tape recorder and other components to amplifier. Keep leads under ten feet in length.

Speakers may be connected with standard flexible line cord (zip-cord) and up to 100 feet of cable may be used without appreciable loss.

Make certain that all audio cables are kept away from speaker cables, power cables, and power transformers, and that speaker cables are kept away from power cables.

POWER AND GROUNDING

The amplifier is furnished with an AC line cord terminated in a three-prong plug. Plug the line cord into a three-wire grounded outlet providing a nominal 120-volt, 50-60 cycle power source. This will ground the amplifier as well as supply power to it.

It is advisable to ground the amplifier. Therefore, if a three-wire outlet is not available, an adapter such as Leviton No. 5017 should be used to convert a standard two-wire outlet for use with three-wire plugs. The adapter is provided with a grounding pigtail which should be connected to the screw holding the wall plate to the receptacle, as shown in figure 3.

NOTE

In some areas, the wall plate screw is not grounded. In this case it will be necessary to connect a grounding wire between the GND terminal on the rear chassis of the amplifier and a water or steam pipe.

AUXILIARY POWER

The auxiliary power receptacle located on the rear chassis can supply power to associated equipment such as a phonograph or tuner. Be sure that the auxiliary component does not draw more than 300 watts. The power switch on the front panel controls this receptacle

and can be used as the main power switch for the auxiliary unit.

The auxiliary power receptacle is a three-wire grounded outlet. Hence, any associated equipment connected to it with a three-prong line cord will be grounded, providing the amplifier has been properly grounded as described above.

INPUT CONNECTIONS

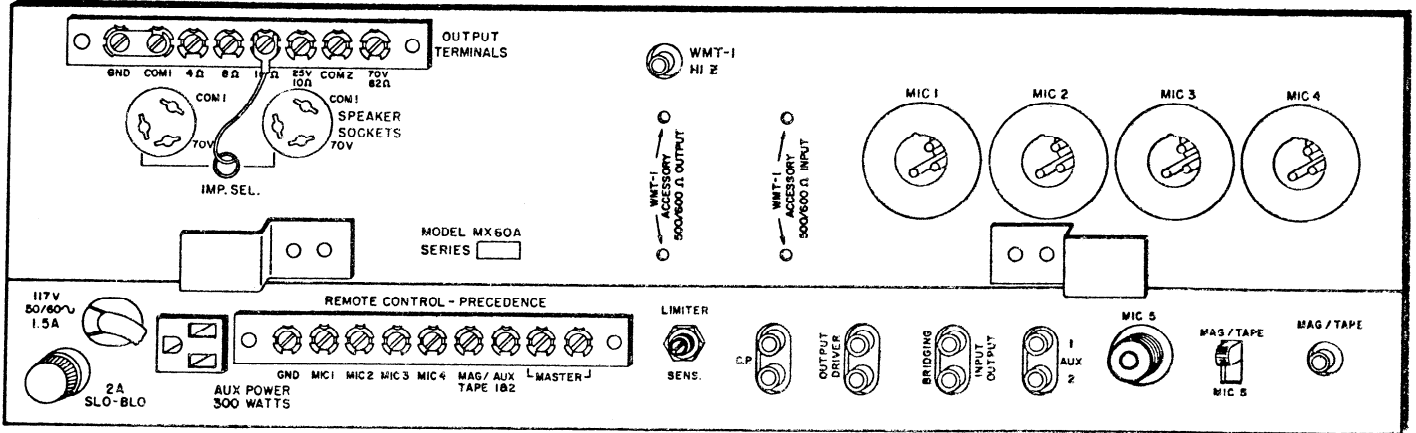

Figure 1 - MX60A Rear Panel

CONNECTING PROGRAM INPUTS

MICROPHONES: A maximum of 5 high-impedance microphones may be connected to the amplifier simultaneously. The microphone cable should be inserted into the microphone receptacle on the rear of the amplifier chassis. The microphone inputs are MIC 1, MIC 2, MIC 3, MIC 4, and INPUT 5. Inputs 1 through 4 use microphone connector Bogen 85-0124-01 or CON-1, Amphenol 91-854 or Cannon XLR-311C. Input 5 uses an Amphenol 75-MCIF or equivalent connector.

Impedance selector switches for MIC 1 through 4 are located on top of the chassis. When using the MIC 1 through MIC 4 microphone inputs, move the respective Impedance Selector switch to either HI Z or LO Z position, depending on microphone impedance. Only high impedance type microphones may be used in INPUT 5, the Input 5 selector switch located on the rear of the chassis should be placed in the MIC 5 position.

The microphone cables should be shielded cable and the connector wired as shown in Figure 2. High-impedance microphones should use single-conductor shielded cable, under 35 feet in length. Low-impedance microphones should utilize two-conductor shielded cable with cable lengths from 50 to 500 feet depending on the microphone. Use three-prong connectors (Bogen 85-0124-01 or CON-1, Amphenol 91-854 or Cannon XLR-311C).

When using low-impedance microphones, insert an input matching transformer into the respective receptacles X1, X2, X3, or X4 on the chassis top (see Figure 4) and place the respective Impedance Selector Switch in the LOW Z position. The following plug-in microphone matching transformers are available from Bogen. Model TM50 for 50 ohms input; TM200 for 150 to 250 ohms and TM500 for 500 to 600 ohms. See schematic diagram, Figure 3, for pin connections.

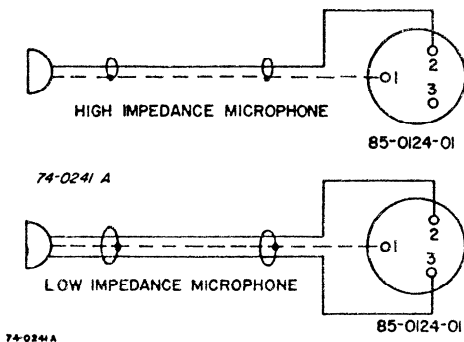

Figure 2 - High and Low Impedance Microphone Connections

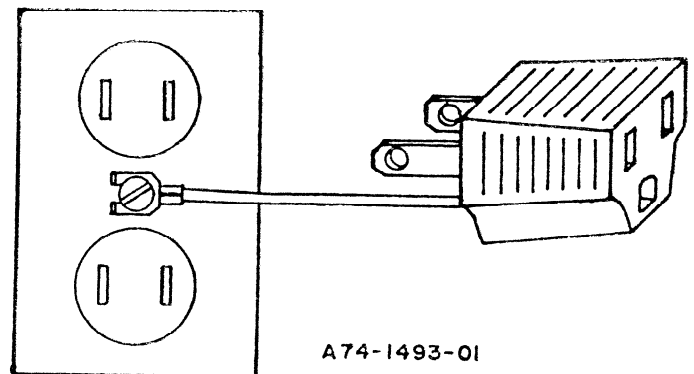

Figure 3 - Connecting and Grounding Line Cord Adapter

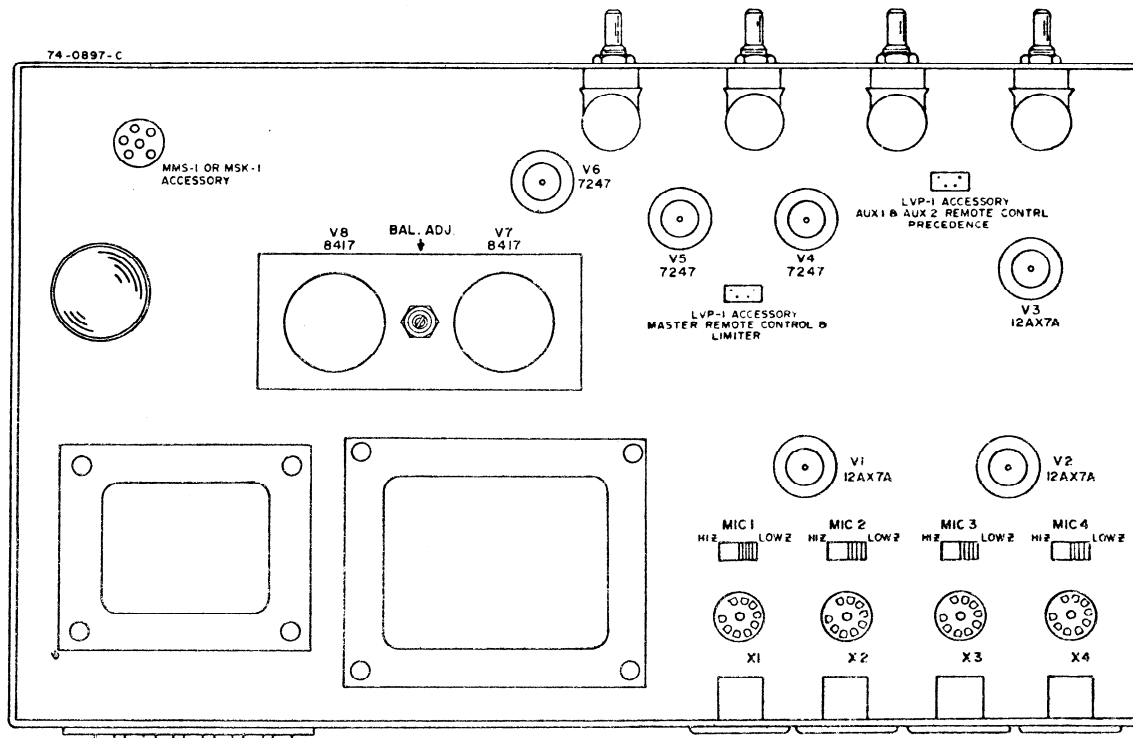

Figure 4 - MX60A Top of Chassis

PHONOGRAPH: Phonographs employing either ceramic, crystal, or magnetic cartridges may be connected to the amplifier. For phonographs employing a magnetic cartridge, connect the input cable to the MAG/TAPE input on the rear of the chassis using a standard single prong phone plug. Use single-conductor shielded audio cable. The appropriate Input Selector switch on the rear of the chassis should be moved to the MAG/TAPE position.

Phonographs employing a ceramic or crystal type cartridge may be connected to either AUX 1 or AUX 2 receptacles on the rear of the chassis. Use single-conductor shielded audio cable terminated in a standard single prong phono plug. It is recommended that a separate ground wire be connected between the phono player base and the amplifier "GND" terminal to minimize any possible hum pickup.

TAPE PLAYBACK: The playback signal from a tape recorder having a built in preamplifier or from a tape deck with no electronics may be connected directly to the amplifier. Tape recorders having a built-in preamplifier should be connected to the AUX 1 or AUX 2 inputs.

The playback head of a tape deck not having electronics, may be connected directly to the MAG/TAPE input. Use single conductor shielded audio cable with a standard single-prong phone plug. Connect an extra ground wire between the chassis of the tape deck and the amplifier GND terminal. Set the Input 5 Selector Switch on the rear chassis to MAG/TAPE position.

AUXILIARY: The AUX inputs may be used for sources other than a phonograph. Any signal source having a high-level high-impedance output may be connected to the inputs. This includes virtually all tuners and tape recorders having preamplifiers. An input signal level of approximately 0.15 volt is required to obtain full output from the amplifier.

REMOTE CONTROL

Each of the six input channels except the bridging input may be remotely controlled by utilizing Bogen accessories SR-2, SR-4, RVC-2, and the LVP-1 limiter. For remote operation of microphone inputs 1 through 4, connect the SR-2 or SR-4 accessory to the appropriate terminals and to GND on the REMOTE CONTROL-PRECEDENCE terminal strip located on the rear panel (see figure 1). The SR-2 provides remote volume control for one or two microphones; the SR-4 will handle up to four mikes.

Input 5 may also be remotely controlled for MAG phono or tape inputs in the same way. However, high impedance microphone inputs to this channel cannot be remotely controlled.

For remote volume control of auxiliary inputs, the LVP-1 limiter must just be plugged into the LVP-1 AUX 1 and AUX 2 Remote Control Precedence socket on the top of the chassis (see figure 3). Then connect the RVC-2 accessory between the AUX 1 and 2 and GND on the Remote Control Precedence terminal strip. The RVC-2 may then be operated as a remote volume control.

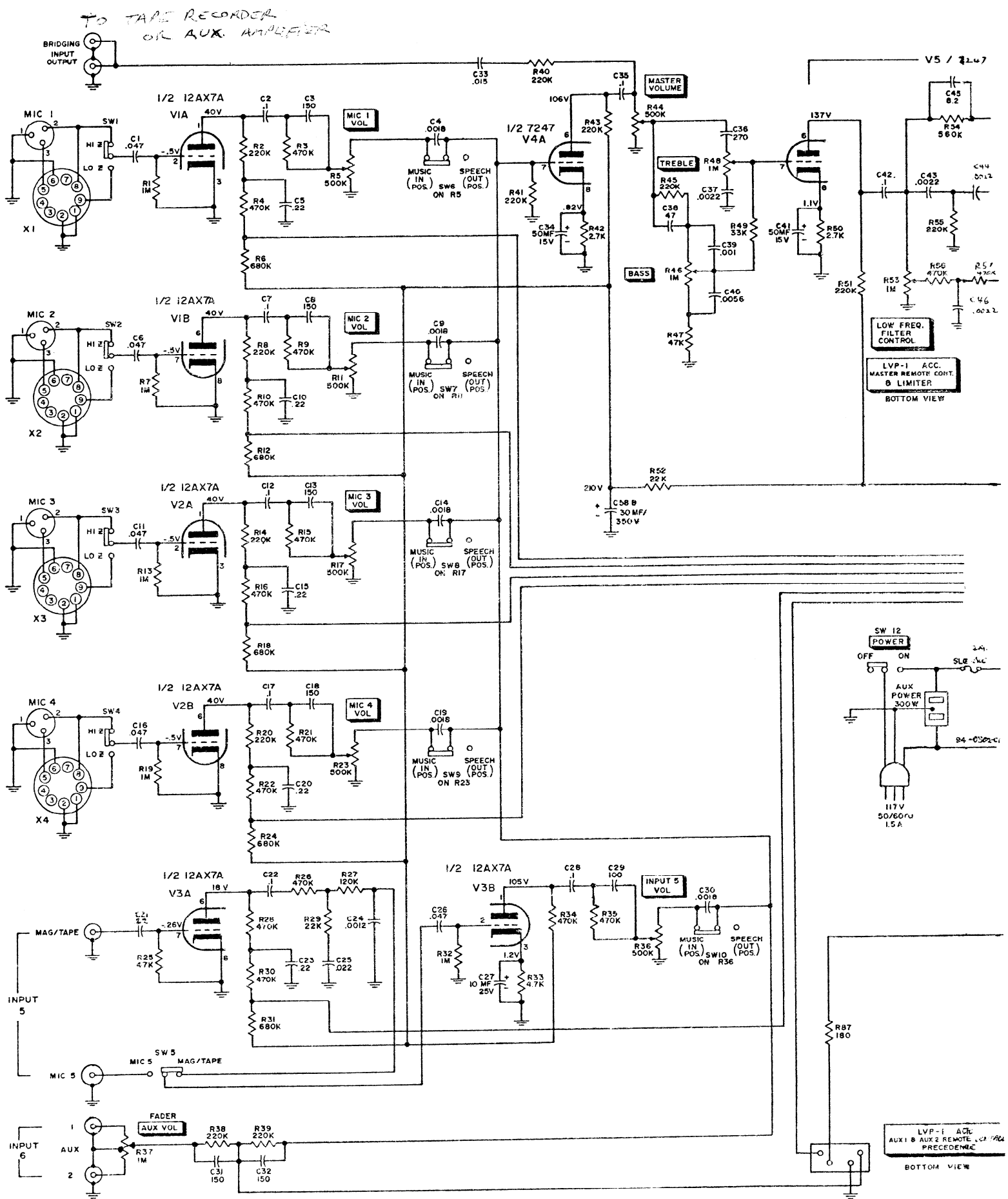
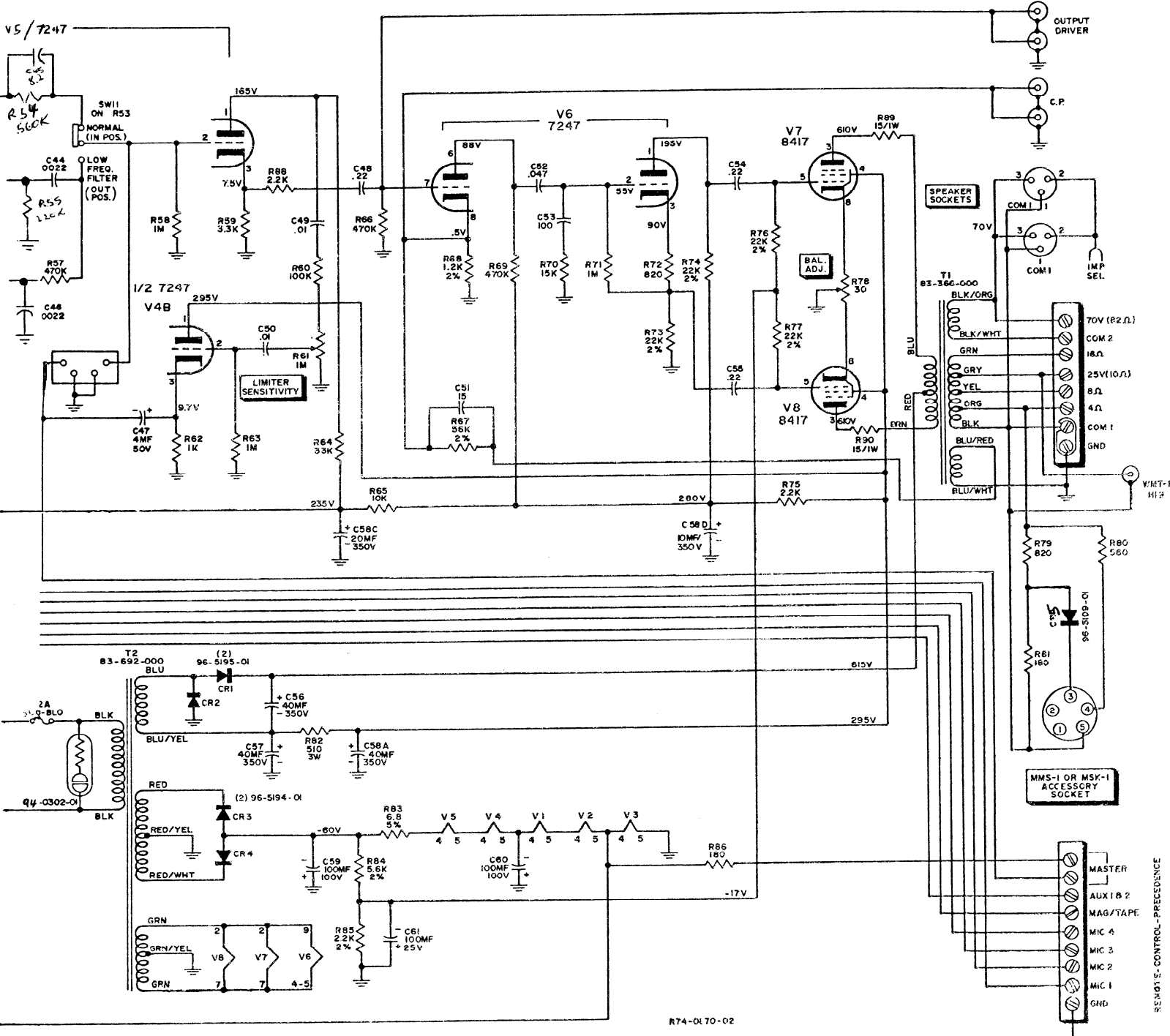

Figure 5 - MX60A



- NOTES:
UNLESS OTHERWISE SPECIFIED
1. ALL RESISTORS ARE 1/2 WATT ±10%
 2. ALL CAPACITORS IN WHOLE NUMBERS ARE IN MMFD, THOSE IN DECIMAL VALUES ARE IN MFD.
 3. ALL VOLTAGES ARE D.C. MEASURED WITH A 20,000 Ω VOLT METER, AND MAY VARY ±20%.

NOTE: CONTROL PRECEDENCE

Schematic Diagram

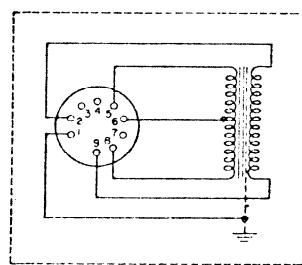

| MODEL | INPUT IMPEDANCE |
|-------|-----------------|
| T 50 | 50 OHMS |
| T 200 | 200 OHMS |
| T 500 | 500 OHMS |

74-0815 A

Schematic Diagram for Plug-in Low Impedance Microphone Transformers

The Master Volume may also be remotely controlled. To do so, plug the LVP-1 limiter into the LVP-1 Master Remote Control and Limiter Socket on the top of the chassis; then connect the RVC-2 accessory to the two terminals on the Remote Control – Precedence terminal strip.

NOTE: The master remote volume control is not grounded. For this reason both wires of the RVC-2 are connected to the two terminals labeled MASTER.

The recommended distance for remote operation is up to 3000 feet with #22 wire. For longer distances, a proportionately heavier wire must be employed.

MICROPHONE PRECEDENCE

Any of the five microphone channels can be set up to provide precedence over any other mike or auxiliary input. To apply precedence to any particular mike input, connect a switch between the terminal for the microphone to be controlled and GND on the Remote Control – Precedence terminal strip. This switch (not supplied by Bogen) disables the input to the controlled channel when closed, and permits another mike input channel to take precedence over it.

OUTPUT CONNECTIONS

SPEAKERS: The amplifier may be used in conjunction with speaker systems rated at 4, 8 and 16 ohms and 25 and 70 volt constant voltage speaker systems (balanced or unbalanced). For detailed information on installation of multiple speaker systems refer to the “Speaker Installation” bulletin (No. 54-5001-02) included with this unit.

In permanent installations, where speakers will remain connected to the amplifier permanently, connect the speaker system directly to the “Speaker Output Terminals” (see figure 1). Connect one lead to the COM terminal and the other to the terminal corresponding to the speaker system’s impedance.

In systems that are moved continually, use the “Speaker Sockets” (speaker plugs Bogen 85-0147-01 are enclosed for this purpose) to provide quick-disconnect of speaker system. In this case, secure the “Speaker Impedance Selector” lead to the appropriate speaker impedance terminal for standard impedance or 25-volt lines. In systems where 70-volt output is used, wire to the connector as follows: For 70-volt operation, connect leads to pins 1 and 3, and connect jumper wire from COM 1 to COM 2 on output terminal strip. For standard impedance and 25 volt systems, connect leads to pins 1 and 2. Refer to figure 6.

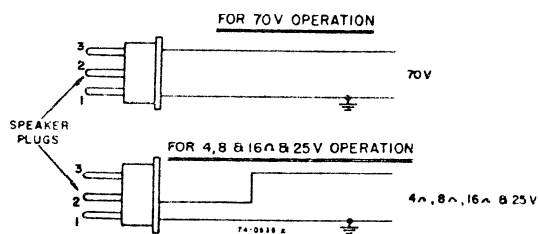

Figure 6 – Speaker Output Plug Wiring

Microphone precedence may also be applied to the auxiliary inputs (Input 6). To do so, an LVP-1 accessory is first plugged into the LVP-1 AUX socket on the chassis. Then connect a switch between the AUX 1 and 2 and the GND terminals on the Remote Control – Precedence terminal strip. When closed, this switch disables the AUX channel inputs to provide precedence for a microphone input.

WMT-1 ACCESSORY

To connect the input from a 500/600-ohm line, mount the WMT-1 transformer on the WMT-1 Accessory Input mounting holes on the rear chassis (see figure 1). Connect the 500/600-ohm input to the three-screw terminal board on the accessory. Connect the phono plug on the WMT-1 to the AUX 1 or AUX 2 input of the amplifier.

NOTE

If another sound source has been plugged into the AUX input, the WMT-1 may be connected to the MIC input of the amplifier. However, the WMT-1 wiring must first be modified, as described in the instruction sheet furnished with the accessory.

NOTE

To obtain 70V balanced output from the speaker socket and still allow for grounding of the 4, 8, 16 and 25V taps, secure the impedance selector lead to COM 2. Connect leads for 70V tap to pins 2 and 3 of speaker socket. This hookup is different from that shown in figure 6.

Correct impedance matching between the amplifier and speaker system is essential for obtaining maximum power. Proceed as follows:

For 25-Volt Output: Connect line to COM 1 and 25-volt terminals. For balanced line, remove ground jumper between GND and COM 1.

For 70-Volt Output: Connect to COM 2 and 70-volt terminals for balanced operation. For unbalanced operation, connect wire between COM 2 and GND.

WMT-1 ACCESSORY

By utilizing a Bogen WMT-1 transformer accessory, a zero-level output at 500/600Ω may be obtained for feeding a telephone line. To feed a 500/600 ohm line, connect the WMT-1 phono plug to the amplifier HI Z output jack. Connect the 500/600Ω line to the terminals on the WMT-1. Holes are provided on the chassis for mounting the WMT-1.

BRIDGING OUTPUT

This can be used as a high level impedance output to feed a tape recorder or auxiliary amplifier. The Master Volume Control will not affect the bridging output level.

PARALLELING AMPLIFIERS

Dual OUTPUT DRIVER and C.P. (cathode paralleling) receptacles are provided to facilitate paralleling of amplifiers without wiring modifications.

Two MX60A amplifiers may be paralleled to increase the output to 120 watts. Paralleling also doubles the number of inputs which may be fed and mixed to the amplifiers. When paralleling amplifiers interconnect the two units as shown in figure 7. The interconnecting cables for the OUTPUT DRIVER and C.P. receptacles should be standard audio shielded cable with phono type plugs at both ends. Do not use wire lengths over 200 feet.

Only transformer taps of the same output impedance should be paralleled. It must be borne in mind that paralleling outputs reduces the impedance.

The MX60A amplifier may also be operated in conjunction with any other tube or transistor type amplifier or booster to drive separate speaker groups. This is done by connecting the OUTPUT DRIVER of the MX60A to the AUX input of the second amplifier or to the input of the booster. The output driver has a low

source impedance, permitting single conductor shielded cable to be used for runs of several hundred feet without appreciable high frequency loss.

OUTPUT LIMITING

The output of the amplifier may be limited to a desired level by means of the Bogen LVP-1 Limiter. This accessory is plugged into the LVP-1 Accessory and Master Remote Control and Limiter socket on top of the chassis (see figure 4). The desired maximum output level is determined by means of the Limiter Sensitivity control on the rear panel (see figure 1). To set the output level for limiter operation proceed as follows:

1. Turn the MASTER VOLUME control fully clockwise to maximum, and the LIMITER SENSITIVITY control counterclockwise to minimum.

2. Rotate the channel input volume control to the point where the volume is sufficient to cover the desired area with the lowest anticipated input signal. In the case of a microphone input this would be the speaker with the weakest voice.

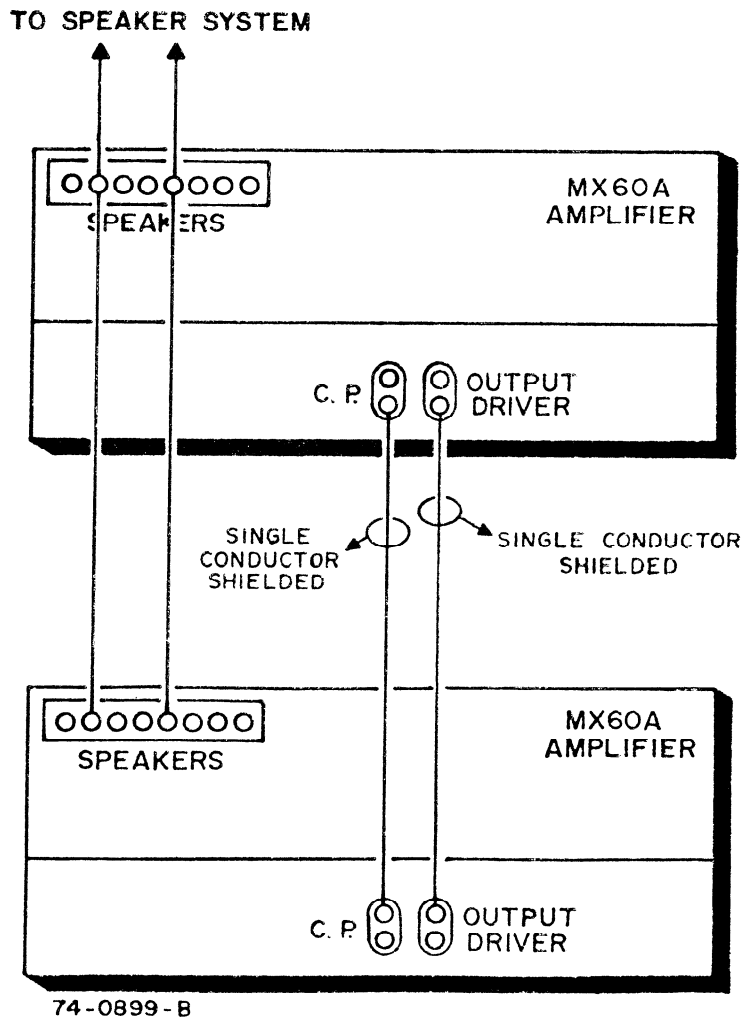

Figure 7 - Paralleling Amplifiers

3. Then feed a signal at the highest anticipated level into the same channel. For mike inputs this could be the person with the loudest voice who is likely to use the amplifier.

4. Rotate the **LIMITER SENSITIVITY** control clockwise until the average volume of the loud signal input is reduced to a satisfactory level. This will determine the maximum output level for the channel.

OPERATING CONTROLS

VOLUME AND FILTER

Each one of the 6 input channels has a separate volume control. Inputs 1 through 5 each incorporate a push-pull speech filter switch. When pushed **IN** the switch provides for wide range (full frequency) response. When the control knob is pulled **OUT**, limited range or speech response is provided. This permits compensation for varying inputs or acoustic conditions. Each switch provides a low frequency cutoff for the input channel it controls, giving the voice a crisp tonal quality so that it can cut through noise and overcome conditions of high reverberation.

MIC 1, MIC 2, MIC 3, MIC 4: Each controls the level of the microphone with which it is associated. Clockwise rotation increases the volume, counterclockwise rotation decreases the volume level. Each of these controls incorporates the filter switch mentioned above.

INPUT 5: This control adjusts the volume level of either the high-impedance microphone or the mag/phono input, depending on the input selected with the **INPUT 5 SELECTOR** switch on the chassis bottom rear. Rotate the control clockwise (to higher numbers) to increase volume. Set the control to the minimum position (0) when Input 5 is not used.

INPUT 6: This control serves a two-fold purpose. It selects either of the two auxiliary inputs and it controls the volume of the selected auxiliary input. Operate the controls as follows: To select the Aux 1 input rotate the control counterclockwise past the center position; rotating the control more counterclockwise increases the Aux 1 volume. To select the Aux 2 input rotate the control clockwise past the center position; rotate the control more clockwise to increase the Aux 2 volume. If the auxiliary input is not to be used, set the control to the mid position (0).

The control can also be used as a "fader" control when both auxiliary inputs are used. This makes it possible to gradually and smoothly reduce the level of

one input and then increase the other when changing inputs. The effect is one of fading from one input to the other.

RESET MARKERS: Each individual volume control has a red reset marker on the skirt of the knob. This marker is used to log a particular setting. This is done as follows:

Make a "dry run" or rehearsal to adjust the volume controls to desired levels. Slide the reset markers to coincide with the midpoint mark on the front panel. The individual knob can now be returned to zero or any other point, allowing instant resetting to the predetermined level (indicated settings).

MASTER: A seventh volume control, marked **MASTER** controls the level of the mixed program. After first adjusting the **MIC** and **INPUTS 5** and **6** controls to mix the program as desired, use this control to control the overall volume of the output signal.

BASS AND TREBLE: These are separate tone controls, operating without interaction. For a flat frequency response, set each control at its midposition. To boost bass or treble response, rotate the proper control in a clockwise direction; to cut response, rotate in a counterclockwise direction.

LOW FREQUENCY FILTER: This push-pull control, calibrated from 10 to 200 cps, introduces a sharp notch at the selected frequency without affecting the rest of the audio range. When this control is pushed in, there is no filtering action. When low frequency filtering is required, pull the knob out and turn it to the setting which best provides the desired filtering to eliminate hum, turntable rumble or other low-frequency noise.

MIC INPUT SELECTORS: These switches are located on the top of the chassis (see Figure 3). They are used to select either **HI Z** or **LOW Z** microphone inputs depending on the type of microphone used; a plug-in transformer is required for low impedance microphones.

OPERATION

Turn the **MX60A** amplifier on by moving the **POWER** switch to the **ON** position. Rotate the **MASTER VOLUME** control fully clockwise. Turn up the volume control for each channel used to the maximum desired level. Volume controls not in use should be kept at zero to prevent noise pickup. After volume of each input has been set, overall volume of the mixed input can be adjusted with the **MASTER** control. Do not try

to overcome insufficient output due to turned down **MASTER** volume control by increasing individual channel controls. This is poor practice and overload will be the result.

If a tuner, tape recorder, or phonograph is used on the **INPUT 5** channel, do not forget to set the appropriate input selector switch on the rear of the chassis to the proper position.

SERVICE

FUSE REPLACEMENT

A two-ampere slow-blow fuse is located on the chassis. To replace this fuse, press the spring-loaded cap slightly inward, rotate counterclockwise slightly and withdraw cap and fuse. Be certain power is disconnected when replacing fuse. Use only fuse of the same rating for replacement. If replacement fuse blows, do not attempt to further operate equipment. Consult an experienced technician or Bogen representative for inspection of the unit.

BOGEN SERVICE

If trouble ever develops with your unit, please do not hesitate to ask our advise or assistance. We are interested in your Bogen unit for as long as you have it. Information can be obtained by writing to Service Department, Bogen Division, P.O. Box 500, Paramus, New Jersey 07652.

When communicating with us give the model number and serial number of your unit. Completely describe the difficulty encountered. Describe the effects each operating control has upon the symptoms of trouble. Include details on electrical connections to associated equipment and list such equipment.

When we receive this information, we will send you service information if the trouble appears to be simple (e.g. bad component, incorrect connections). If trouble requires servicing, we shall send you the name and address of the nearest Bogen authorized service agency to which you can send your unit for repair.

When shipping your unit, pack instrument well using the original shipping carton and filler material to prevent damage in transit. Send unit, fully insured and prepaid, via railway express. Do not ship via parcel post unless so instructed. The unit will be promptly repaired and returned to you via express collect.

BALANCING OUTPUT TUBES

If any of the two 8417 output tubes are replaced, balance tubes as follows:

1. Connect a dummy load across amplifier output, which is capable of handling full rated power output. In addition connect an AC VTVM and an oscilloscope across dummy load.
2. Feed a 1,000 cycle signal into the HI Z input and adjust signal level to point where clipping occurs. This provides slightly over full rated output of amplifier as measured with AC VTVM.
3. The BALANCE ADJUSTMENT control located on top of chassis adjacent to output tubes, and is a screwdriver adjustment. Rotate this control to position which provides equal clipping on oscilloscope.

NOTE: *If a distortion analyzer is available, this should be used in preference to oscilloscope. In this case, a distortion reading of approximately 1 percent or less should be measured at full output, provided everything else in amplifier is operating properly.*

For field service, where test equipment is not available, set balance control to approximately center position.

REPLACEMENT PARTS

The components used in Bogen equipment, with exception of items listed below, are standard parts available through all reputable parts jobbers. However, several parts are custom-made to strict Bogen specifications and should be replaced only with genuine Bogen parts. These custom-made parts are listed here and are available through Bogen distributors, service

agencies or direct from the factory.

When ordering a part, specify part number and description of the part as listed below. Specify the model and give the series designation, which is a run letter followed by numbers, stamped or screened on the rear of the chassis.

| Ref. No. | Part No. | Description |
|----------|------------|--|
| C27 | 79-005-051 | Capacitor, Electrolytic 10 mfd, 25V |
| C34 | 79-005-036 | Capacitor, Electrolytic 50 mfd, 15V |
| C41 | 79-005-036 | Capacitor, Electrolytic 50 mfd, 15V |
| C47 | 79-005-055 | Capacitor, Electrolytic 4 mfd, 50V |
| C56, 57 | 79-001-117 | Capacitor, Electrolytic 40 mfd, 350V |
| C58 | 70-010-051 | Capacitor, Electrolytic 40-30-20-10 mfd, 350V |
| C59 | 79-001-067 | Capacitor, Electrolytic 100 mfd, 100V |

| Ref. No. | Part No. | Description |
|----------|------------|--|
| C60 | 79-001-067 | Capacitor, Electrolytic 100 mfd, 100V |
| C61 | 79-005-050 | Capacitor, Electrolytic 100 mfd, 25V |
| CR1, 2 | 96-5195-01 | Diode, Silicon (ECG 5809) |
| CR3, 4 | 96-5194-01 | Diode, Silicon (ECG 156) |
| CR5 | 96-5109-01 | Diode, Silicon (ECG 116) |
| R5 | 77-001-592 | Control, MIC 1 Volume |
| R11 | 77-001-592 | Control, MIC 2 Volume |
| R17 | 77-001-592 | Control, MIC 3 Volume |
| R23 | 77-001-592 | Control, MIC 4 Volume |
| R36 | 77-001-593 | Control, Input 5 Volume |
| R37 | 77-001-596 | Control, Input 6, Fader |

| | | | | | |
|---------|------------|----------------------------------|-------|------------|-------------------------|
| R44 | 77-001-595 | Control, Master Volume | R84 | 75-235-562 | Resistor, 5600Ω ½W, 2% |
| R46 | 77-001-515 | Control, Bass | R85 | 75-235-222 | Resistor, 2200Ω, ½W, 2% |
| R48 | 77-001-515 | Control, Treble | SW1-5 | 81-003-016 | Switch, Input Selector |
| R53 | 77-001-594 | Control, Low Frequency filter | SW12 | 81-003-053 | Switch, Power |
| R61 | 77-001-321 | Control, Limiter Sensitivity | T1 | 83-366-000 | Transformer, Output |
| R67 | 75-235-563 | Resistor, 56K, ½W, 2% | T2 | 83-692-000 | Transformer, Power |
| R68 | 75-235-122 | Resistor, 1200Ω ½W, 2% | | 03-059201 | Knob & Skirt (0-10) |
| R73, 74 | 75-235-223 | Resistor, 22K, ½W, 2% | | 03-0593-01 | Knob & Skirt (0-5-0) |
| R76, 77 | 75-235-223 | Resistor, 22K, ½W, 2% | | 03-0590-01 | Knob |
| R78 | 77-001-563 | Control, Balance Adjust | | 02-9029-01 | Reset Marker |
| R83 | 76-102-132 | Resistor, 6.8Ω, ½W, 5% | | 85-0151-01 | Plug, Speaker, 5-pin |
| | | | | 85-0147-01 | Plug, Speaker, 3-pin |

— OWNER'S WARRANTY —

Bogen solid state sound and intercom equipment is guaranteed against defects in material and workmanship for one year from the date of sale to the original purchaser, provided that the equipment has not been subjected to abuse or accident or altered in any way. Any part of the equipment covered by this warranty which, with normal installation and use, becomes defective will be repaired or replaced by Bogen, provided the equipment is delivered or shipped prepaid and insured to our authorized service station or to the Bogen Factory Service Department, Route 4 and Forest Avenue, Paramus, New Jersey 07652. The equipment may be picked up by you personally or will be returned to you freight prepaid.

Models containing vacuum tubes carry the same warranty as above, except that it does not apply to the vacuum tubes, which are guaranteed for 90 days.

The registration card enclosed with the equipment must be completed and mailed within five days of purchase to place the warranty in effect.

LEAR SIEGLER, INC.



BOGEN DIVISION
P.O. BOX 500
PARAMUS, N. J. 07652