

CLASS	DWG NO.	SR	1	1
SD	187342			
REVISIONS				
REV	DESCRIPTION	CHK	ENG	DATE
01	ECN-20156: BY DESIGN RESOURCES	MC	MC	06/25/96
02	ECN20338: ADDED R104,R204,R105, AND R205. REMOVED R124 & R224. 6.81K WAS 8.25K	AH	MC	07/29/96

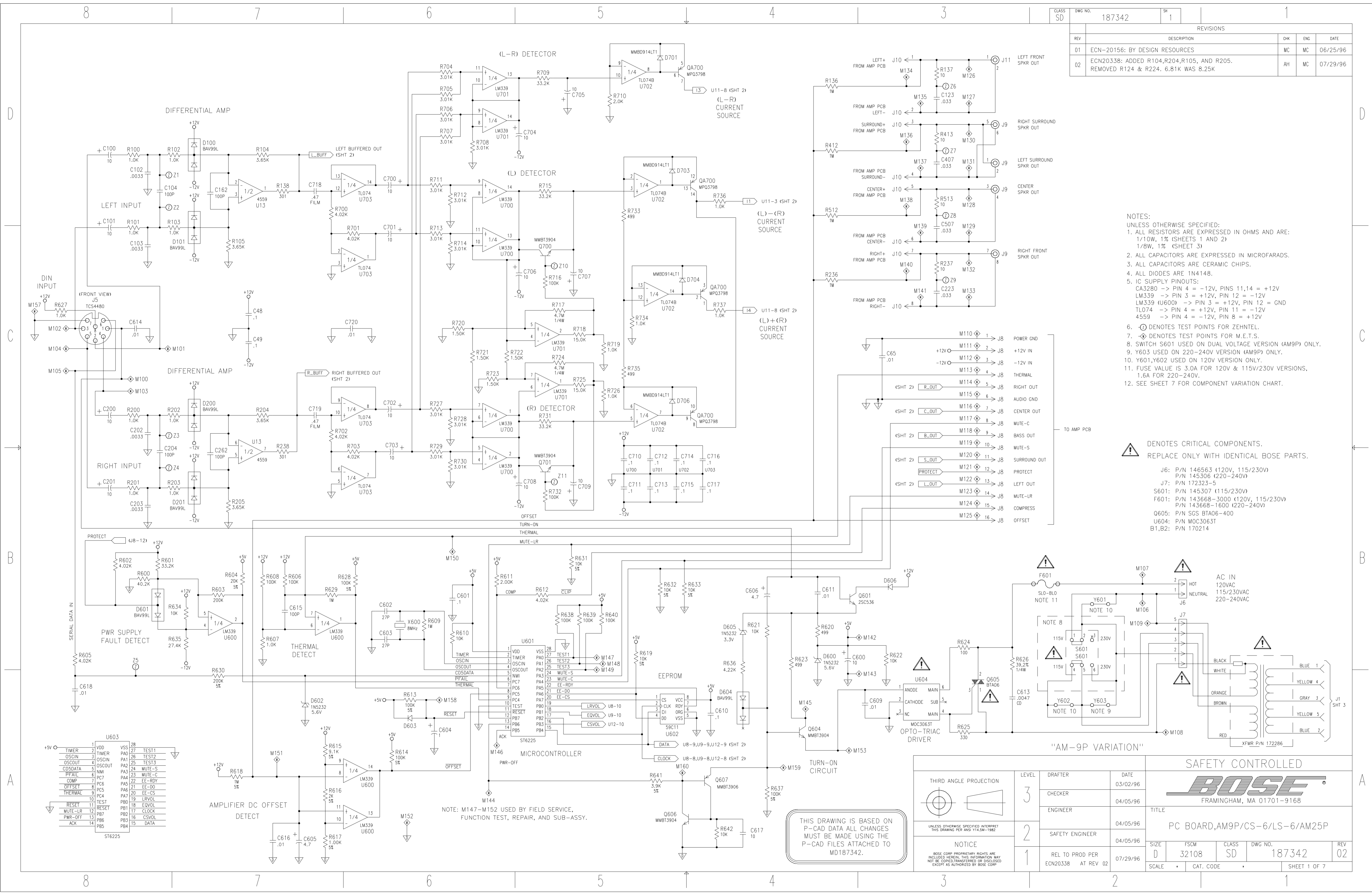

- NOTES:
- UNLESS OTHERWISE SPECIFIED: ALL RESISTORS ARE EXPRESSED IN OHMS AND ARE: 1/10W, 1% (SHEETS 1 AND 2) 1/8W, 1% (SHEET 3)
 - ALL CAPACITORS ARE EXPRESSED IN MICROFARADS.
 - ALL CAPACITORS ARE CERAMIC CHIPS.
 - ALL DIODES ARE 1N4148.
 - IC SUPPLY PINOUTS:
CA3280 -> PIN 4 = -12V, PINS 11,14 = +12V
LM339 -> PIN 3 = +12V, PIN 12 = -12V
LM339 (U600) -> PIN 3 = +12V, PIN 12 = GND
TL074 -> PIN 4 = +12V, PIN 11 = -12V
4559 -> PIN 4 = -12V, PIN 8 = +12V
 - ⊙ DENOTES TEST POINTS FOR ZEHNTEL.
 - ⊙ DENOTES TEST POINTS FOR M.E.T.S.
 - SWITCH S601 USED ON DUAL VOLTAGE VERSION (AM9P) ONLY.
 - Y603 USED ON 220-240V VERSION (AM9P) ONLY.
 - Y601, Y602 USED ON 120V VERSION ONLY.
 - FUSE VALUE IS 3.0A FOR 120V & 115V/230V VERSIONS. 1.6A FOR 220-240V.
 - SEE SHEET 7 FOR COMPONENT VARIATION CHART.

- ⚠ DENOTES CRITICAL COMPONENTS.
REPLACE ONLY WITH IDENTICAL BOSE PARTS.
- J6: P/N 146563 (120V, 115/230V)
P/N 145306 (220-240V)
 - J7: P/N 172323-5
 - S601: P/N 145307 (115/230V)
 - F601: P/N 143668-3000 (120V, 115/230V)
P/N 143668-1600 (220-240V)
 - Q605: P/N SGS BTA06-400
 - U604: P/N MOC3063T
 - B1,B2: P/N 170214

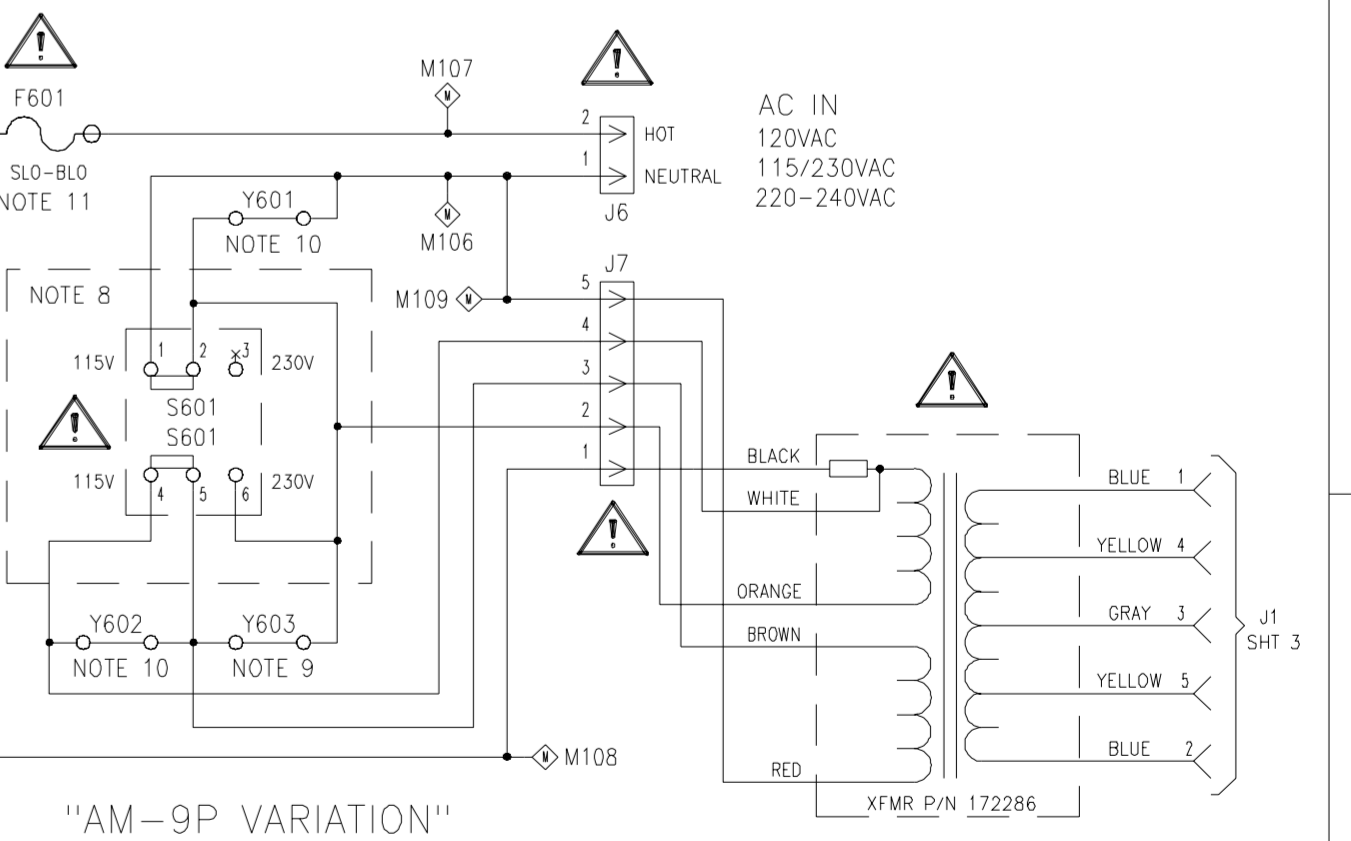

THIRD ANGLE PROJECTION		LEVEL	DRAFTER	DATE
UNLESS OTHERWISE SPECIFIED INTERPRET THIS DRAWING PER ANSI Y14.5M-1982		3	CHECKER	03/02/96
NOTICE		2	ENGINEER	04/05/96
BOSE CORP PROPRIETARY RIGHTS ARE INCLUDED HEREIN. THIS INFORMATION MAY NOT BE COPIED, TRANSFERRED OR DISCLOSED EXCEPT AS AUTHORIZED BY BOSE CORP		1	SAFETY ENGINEER	04/05/96
			REL TO PROD PER	07/29/96
			ECN20338 AT REV 02	
SCALE	CAT. CODE	TITLE		REV
		PC BOARD,AM9P/CS-6/LS-6/AM25P		02
		SAFETY CONTROLLED		
		FRAMINGHAM, MA 01701-9168		
		SIZE		DWG NO.
		32108		187342
		CLASS		REV
		SD		02
		SHEET 1 OF 7		

THIS DRAWING IS BASED ON P-CAD DATA ALL CHANGES MUST BE MADE USING THE P-CAD FILES ATTACHED TO MD187342.

NOTE: M147-M152 USED BY FIELD SERVICE, FUNCTION TEST, REPAIR, AND SUB-ASSY.

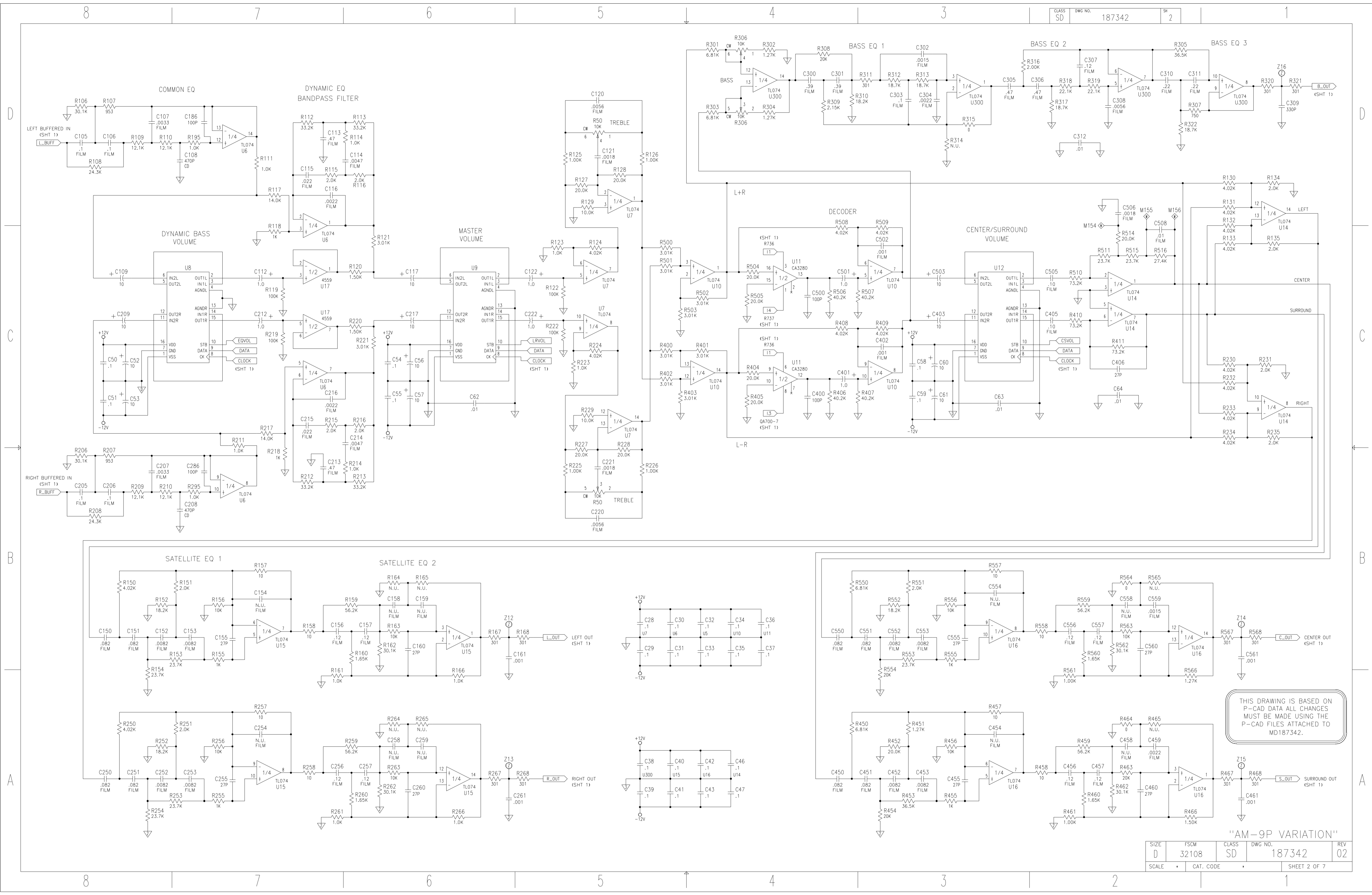

THIS DRAWING IS BASED ON P-CAD DATA ALL CHANGES MUST BE MADE USING THE P-CAD FILES ATTACHED TO MD187342.

"AM-9P VARIATION"

SIZE	FSCM	CLASS	DWG NO.	REV
D	32108	SD	187342	02
SCALE	CAT. CODE	SHEET 2 OF 7		

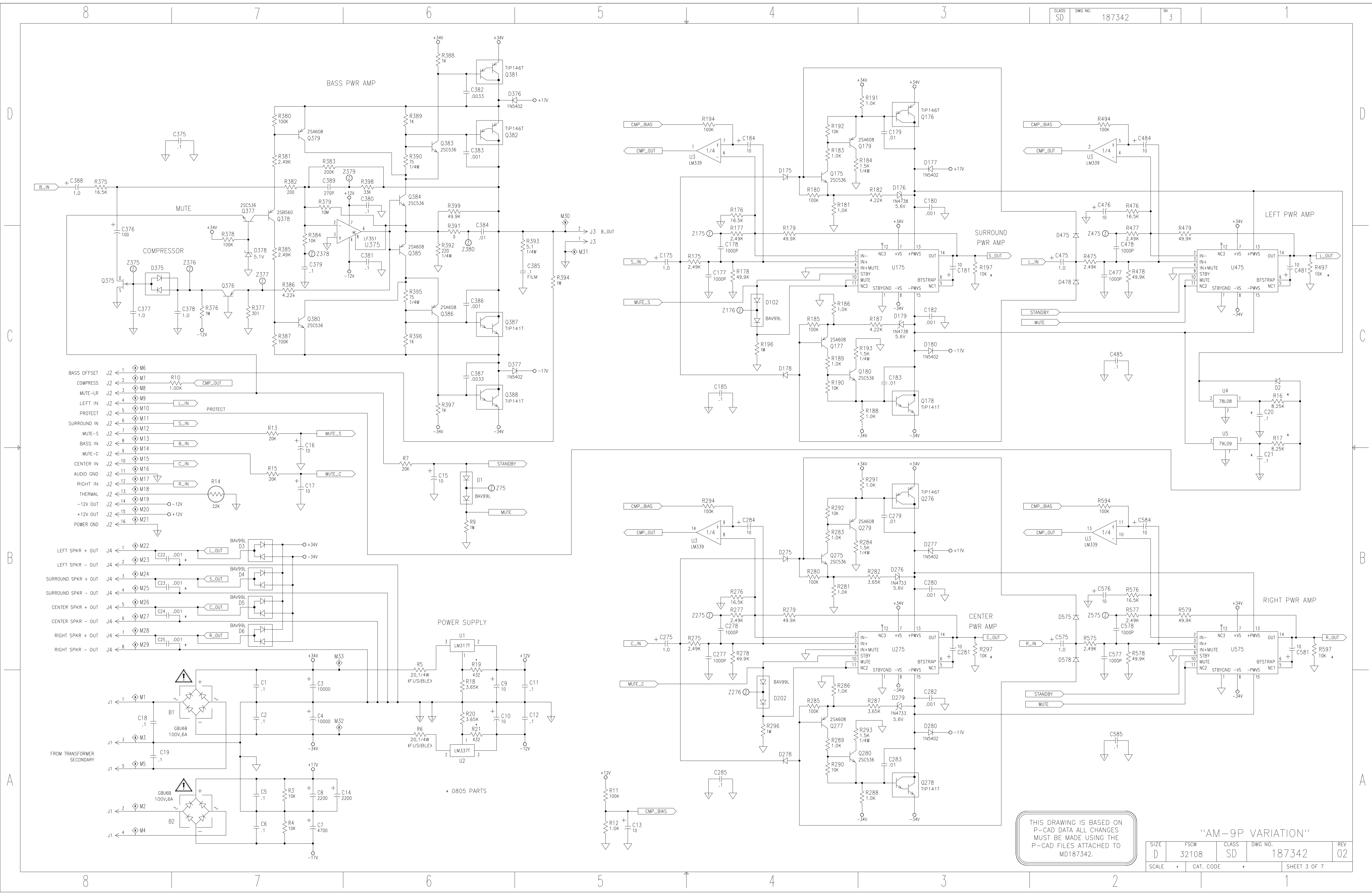

THIS DRAWING IS BASED ON P-CAD DATA ALL CHANGES MUST BE MADE USING THE P-CAD FILES ATTACHED TO MD187342.

"AM-9P VARIATION"

SIZE D	FSCM 32108	CLASS SD	DWG NO. 187342	REV 02
SCALE	CAT. CODE		SHEET 3 OF 7	

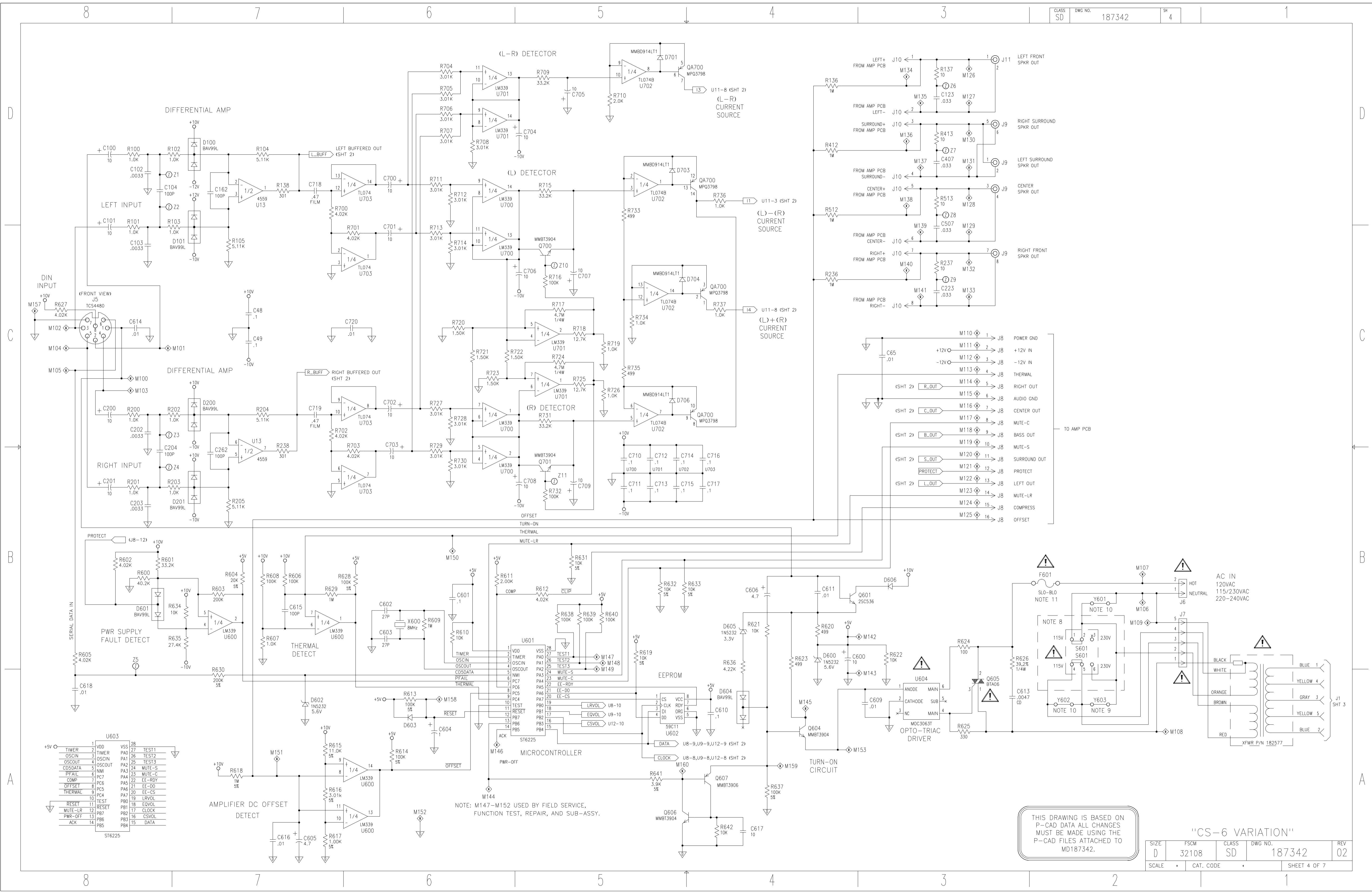

THIS DRAWING IS BASED ON P-CAD DATA ALL CHANGES MUST BE MADE USING THE P-CAD FILES ATTACHED TO MD187342.

"CS-6 VARIATION"

SIZE D	FSCM 32108	CLASS SD	DWG NO. 187342	REV 02
SCALE	CAT. CODE	SHEET 4 OF 7		

NOTE: M147-M152 USED BY FIELD SERVICE, FUNCTION TEST, REPAIR, AND SUB-ASSY.

U603

1	VDD	28	TEST1
2	TIMER	27	TEST2
3	OSCIN	26	TEST3
4	OSCOUT	25	TEST4
5	CDSDATA	24	MUTE-S
6	PFAIL	23	MUTE-C
7	PC7	22	EE-RDY
8	PC6	21	EE-DO
9	PC5	20	EE-CS
10	PC4	19	LRVOL
11	RESET	18	EOVOL
12	MUTE-LR	17	CLOCK
13	PWR-OFF	16	CSVOL
14	ACK	15	DATA
15		14	

ST6225

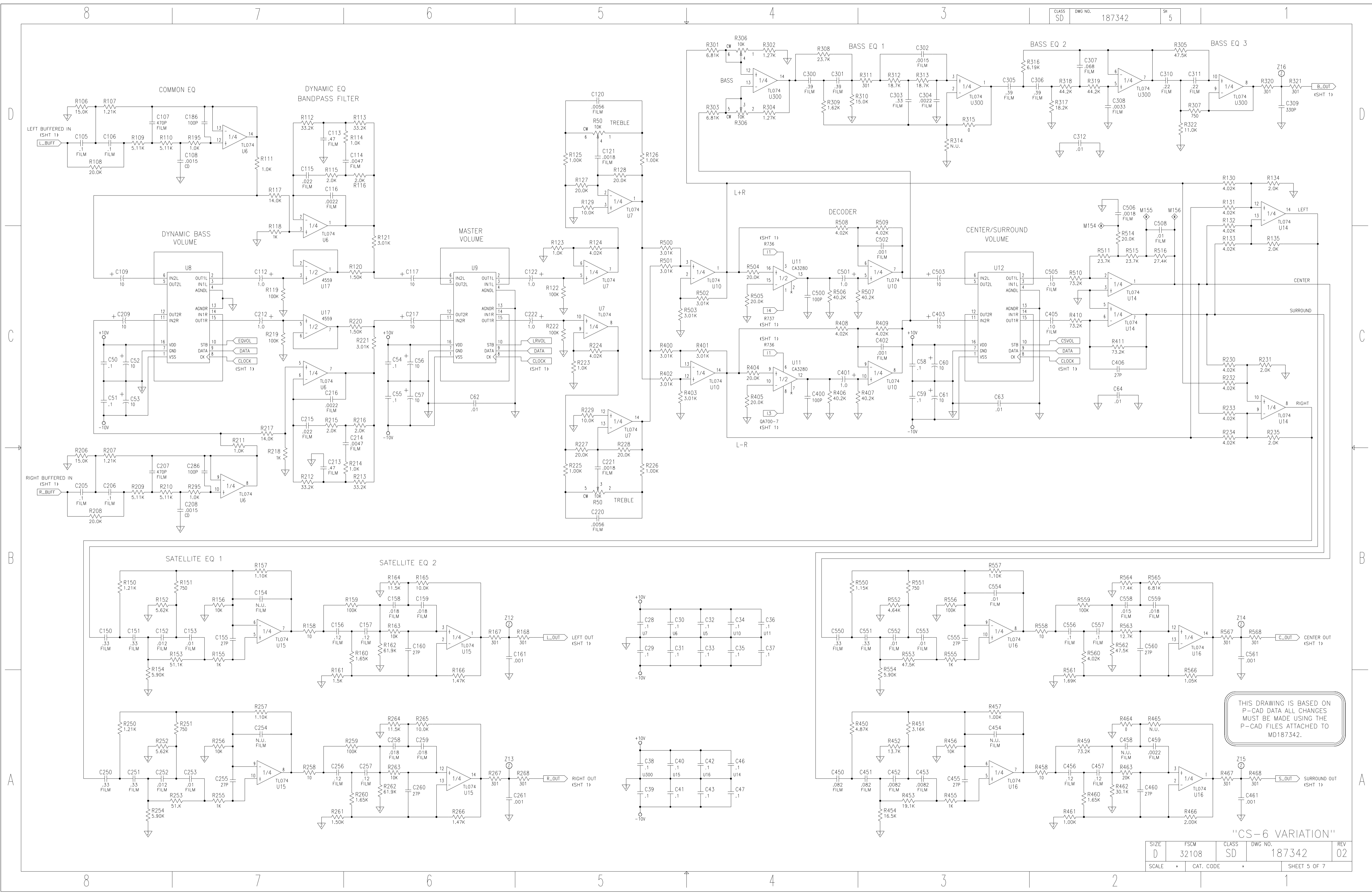

THIS DRAWING IS BASED ON P-CAD DATA ALL CHANGES MUST BE MADE USING THE P-CAD FILES ATTACHED TO MD187342.

"CS-6 VARIATION"

SIZE D	FSCM 32108	CLASS SD	DWG NO. 187342	REV 02
SCALE	CAT. CODE	SHEET 5 OF 7		

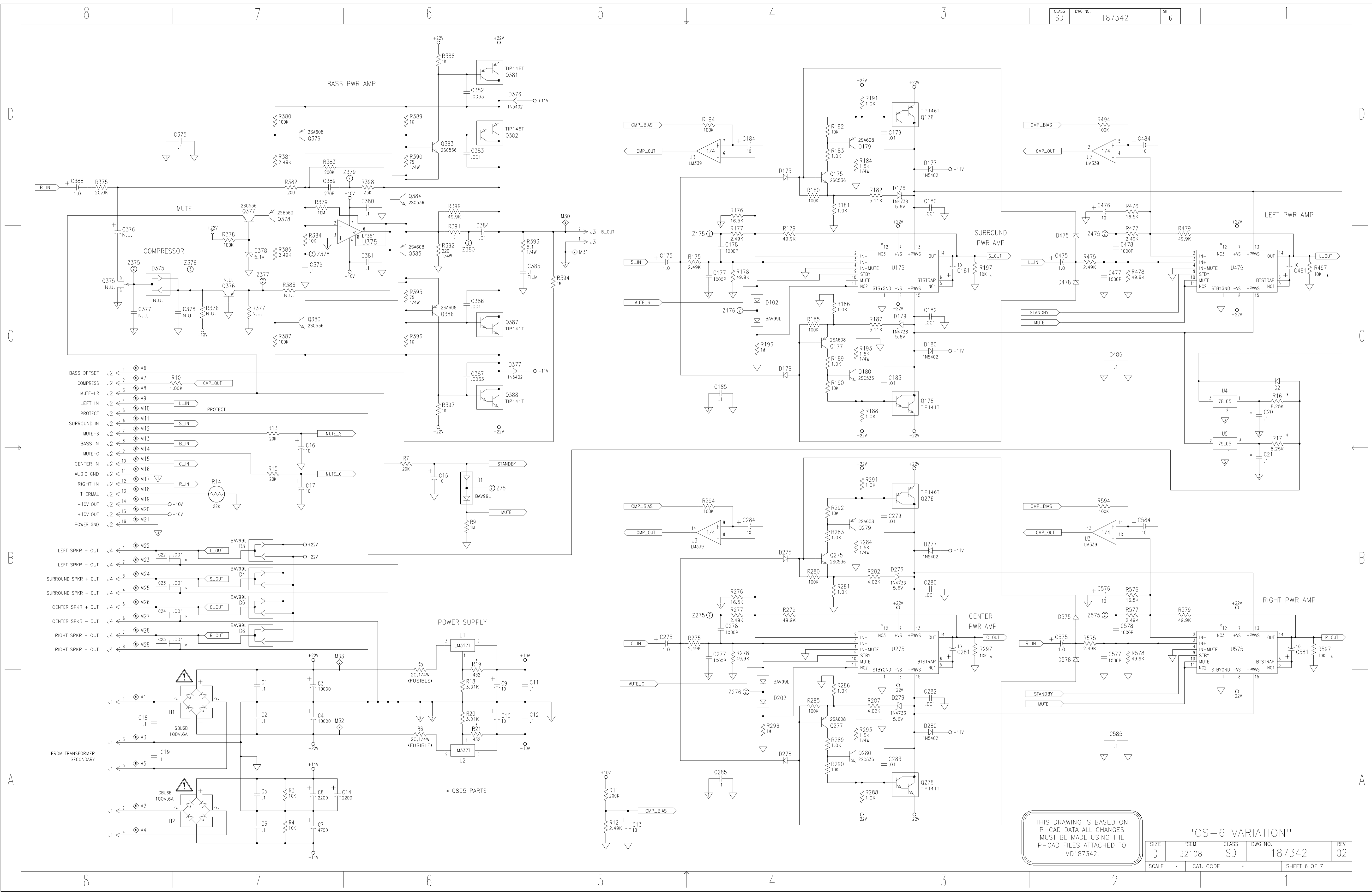

THIS DRAWING IS BASED ON P-CAD DATA ALL CHANGES MUST BE MADE USING THE P-CAD FILES ATTACHED TO MD187342.

"CS-6 VARIATION"				
SIZE	FSCM	CLASS	DWG NO.	REV
D	32108	SD	187342	02
SCALE	CAT. CODE		SHEET 6 OF 7	

AM-25P COMPONENT VALUE VARIATION CHART (DIFFERENT THAN AM-9P VALUES SHOWN ON SHEETS 1-3)	
COMPONENT REFERENCE DESIGNATOR	COMPONENT VALUE USED
C300, C301	.22uF
C302	.001uF
C303	.1uF
C304	.0056uF
C307	.068uF
C308	.0068uF
C310, C311	.12uF
R104, R204, R105, R205	6.81K
R305	86.6K
R307	1.00K
R308	301K
R309	7.50K
R310	47.5K
R312, R313	26.7K
R316	4.75K
R317	15.0K
R318, R319	44.2K
R322	49.9K
R627	3.01K

AM-9P "ZONE 2" COMPONENT VALUE VARIATION CHART (DIFFERENT THAN AM-9P VALUES SHOWN ON SHEETS 1-3)	
COMPONENT REFERENCE DESIGNATOR	COMPONENT VALUE USED
R124, R224	8.25K
R627	2.00K

LS-6 COMPONENT VALUE VARIATION CHART (DIFFERENT THAN CS-6 VALUES SHOWN ON SHEETS 4-6)	
COMPONENT REFERENCE DESIGNATOR	COMPONENT VALUE USED
R124, R224	4.02K
R627	1.00K

THIS DRAWING IS BASED ON P-CAD DATA ALL CHANGES MUST BE MADE USING THE P-CAD FILES ATTACHED TO MD187342.

CLASS	DWG NO.	SR	1	1
SD	190341			
REVISIONS				
REV	DESCRIPTION	CHK	ENG	DATE
01	REVISED PER ECN 22645 R.O.	AH	MC	9/26/97

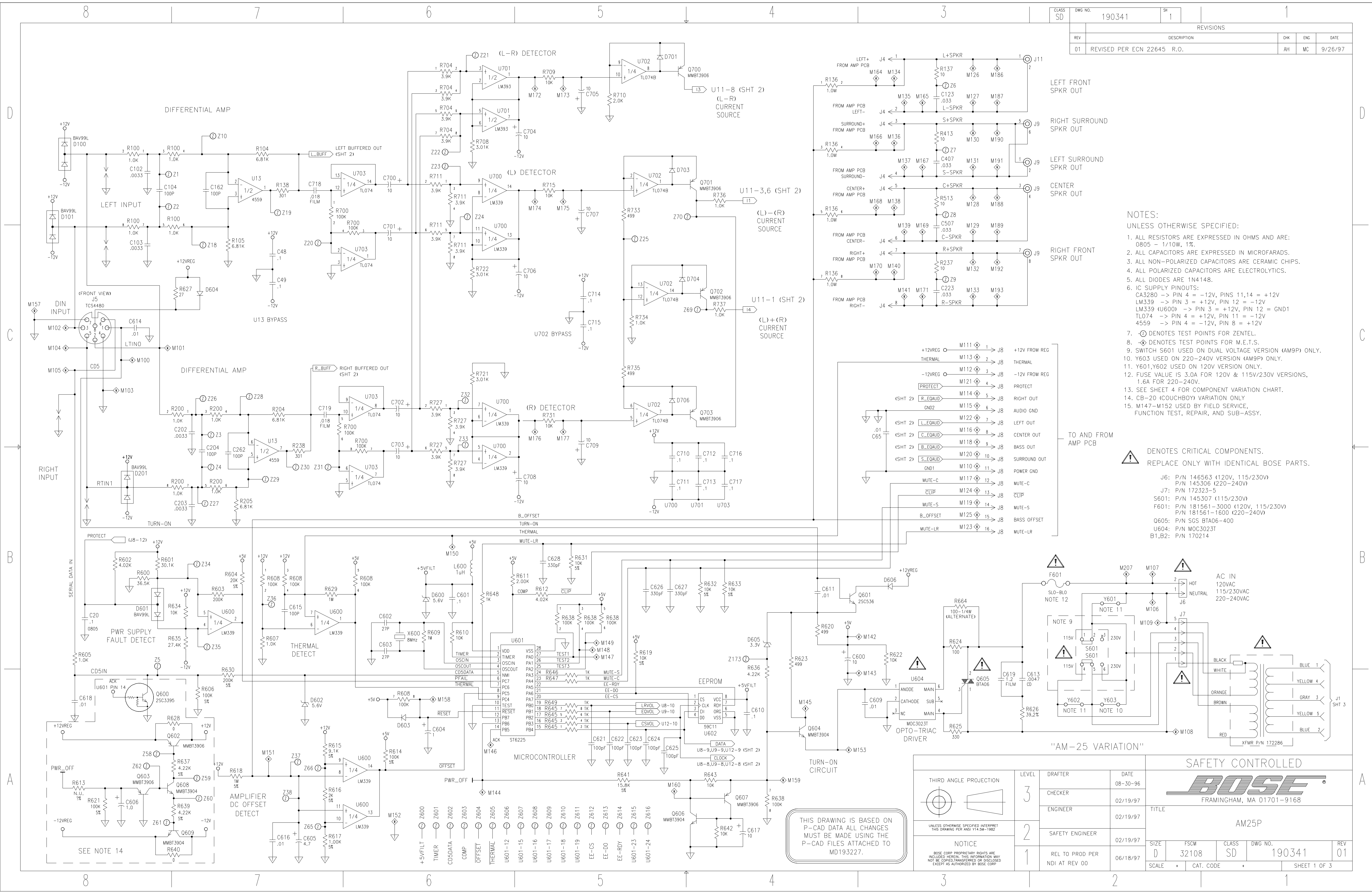

- NOTES:
UNLESS OTHERWISE SPECIFIED:
- ALL RESISTORS ARE EXPRESSED IN OHMS AND ARE: 0805 - 1/10W, 1%. 0805 - 1/10W, 1%.
 - ALL CAPACITORS ARE EXPRESSED IN MICROFARADS.
 - ALL NON-POLARIZED CAPACITORS ARE CERAMIC CHIPS.
 - ALL POLARIZED CAPACITORS ARE ELECTROLYTICS.
 - ALL DIODES ARE 1N4148.
 - IC SUPPLY PINOUTS:
CA3280 -> PIN 4 = -12V, PINS 11,14 = +12V
LM339 -> PIN 3 = +12V, PIN 12 = -12V
LM339 (U600) -> PIN 3 = +12V, PIN 12 = GND1
TL074 -> PIN 4 = +12V, PIN 11 = -12V
4559 -> PIN 4 = -12V, PIN 8 = +12V
 - ⊙ DENOTES TEST POINTS FOR ZENTEL.
 - ⊙ DENOTES TEST POINTS FOR M.E.T.S.
 - SWITCH S601 USED ON DUAL VOLTAGE VERSION (AM9P) ONLY.
 - Y603 USED ON 220-240V VERSION (AM9P) ONLY.
 - Y601, Y602 USED ON 120V VERSION ONLY.
 - FUSE VALUE IS 3.0A FOR 120V & 115V/230V VERSIONS, 1.6A FOR 220-240V.
 - SEE SHEET 4 FOR COMPONENT VARIATION CHART.
 - CB-20 (COUCHBOY) VARIATION ONLY.
 - M147-M152 USED BY FIELD SERVICE, FUNCTION TEST, REPAIR, AND SUB-ASSY.

⚠ DENOTES CRITICAL COMPONENTS.
REPLACE ONLY WITH IDENTICAL BOSE PARTS.

- J6: P/N 146563 (120V, 115/230V)
P/N 145306 (220-240V)
- J7: P/N 172323-5
- S601: P/N 145307 (115/230V)
- F601: P/N 181561-3000 (120V, 115/230V)
P/N 181561-1600 (220-240V)
- Q605: P/N SGS BTA06-400
- U604: P/N MOC3023T
- B1, B2: P/N 170214

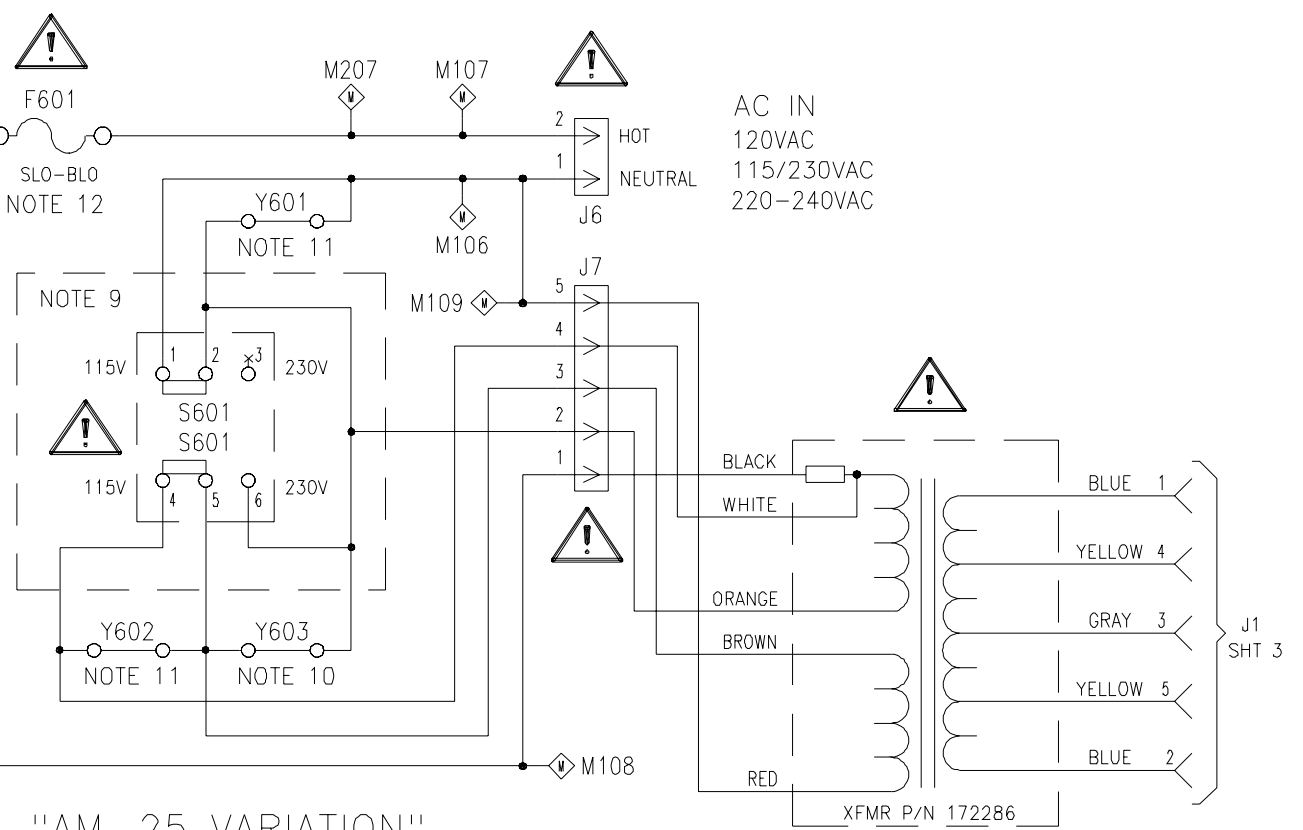

THIRD ANGLE PROJECTION		LEVEL	DRAFTER	DATE
UNLESS OTHERWISE SPECIFIED INTERPRET THIS DRAWING PER ANSI Y14.5M-1982		3		08-30-96
NOTICE		2	CHECKER	02/19/97
BOSE CORP PROPRIETARY RIGHTS ARE INCLUDED HEREIN. THIS INFORMATION MAY NOT BE COPIED, TRANSMITTED OR DISCLOSED EXCEPT AS AUTHORIZED BY BOSE CORP.		1	ENGINEER	02/19/97
			SAFETY ENGINEER	02/19/97
			REL TO PROD PER	06/18/97
			NDI AT REV 00	
SCALE	CAT. CODE	TITLE		SHEET 1 OF 3
		AM25P		
		SIZE	FSCM	CLASS
		D	32108	SD
		DWG NO.	190341	REV
				01

THIS DRAWING IS BASED ON P-CAD DATA ALL CHANGES MUST BE MADE USING THE P-CAD FILES ATTACHED TO MD193227.

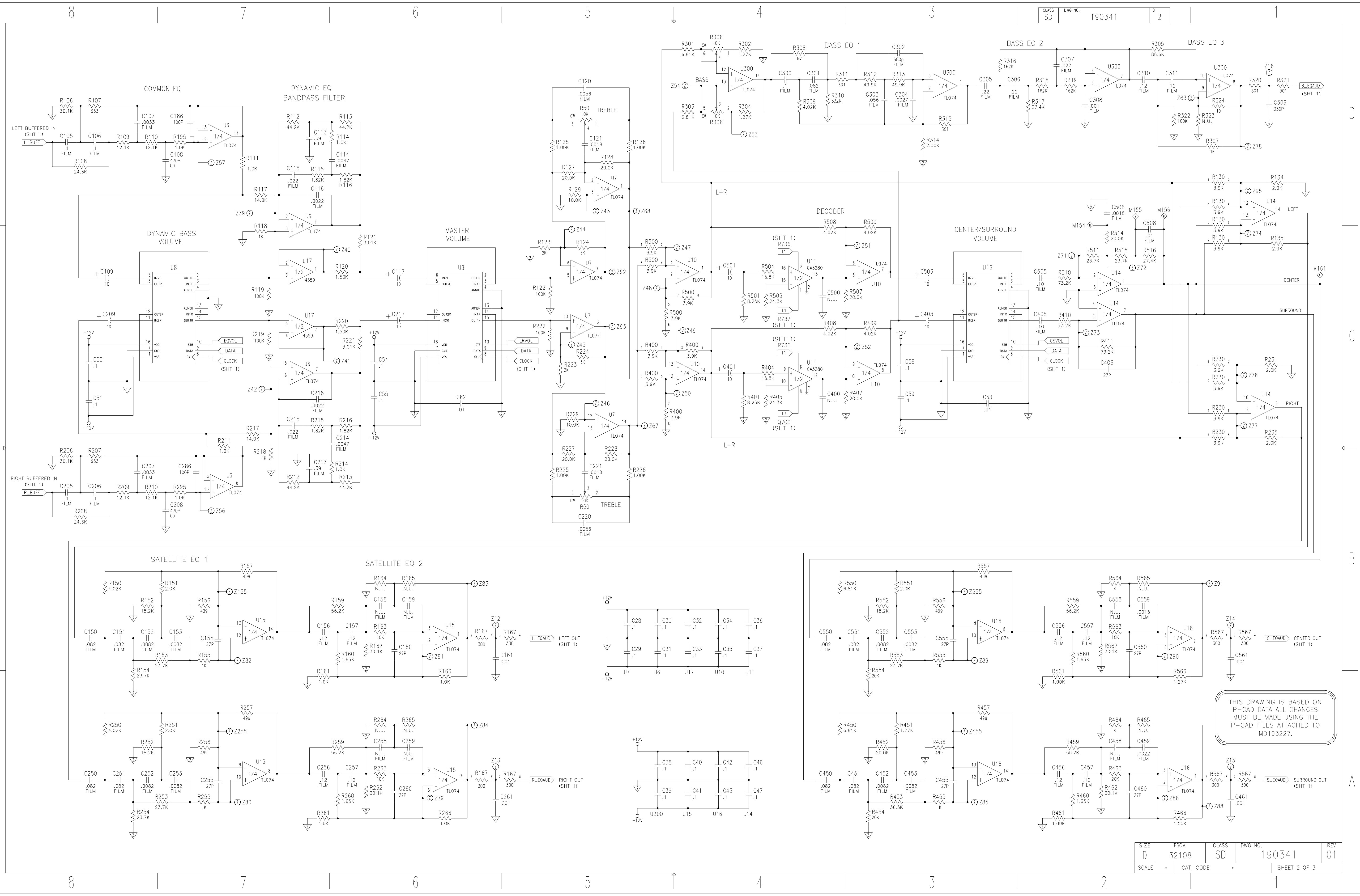

9. SWITCH S601 USED ON DUAL VOLTAGE VERSION (AM9P) ONLY.

THIS DRAWING IS BASED ON P-CAD DATA ALL CHANGES MUST BE MADE USING THE P-CAD FILES ATTACHED TO MD193227.

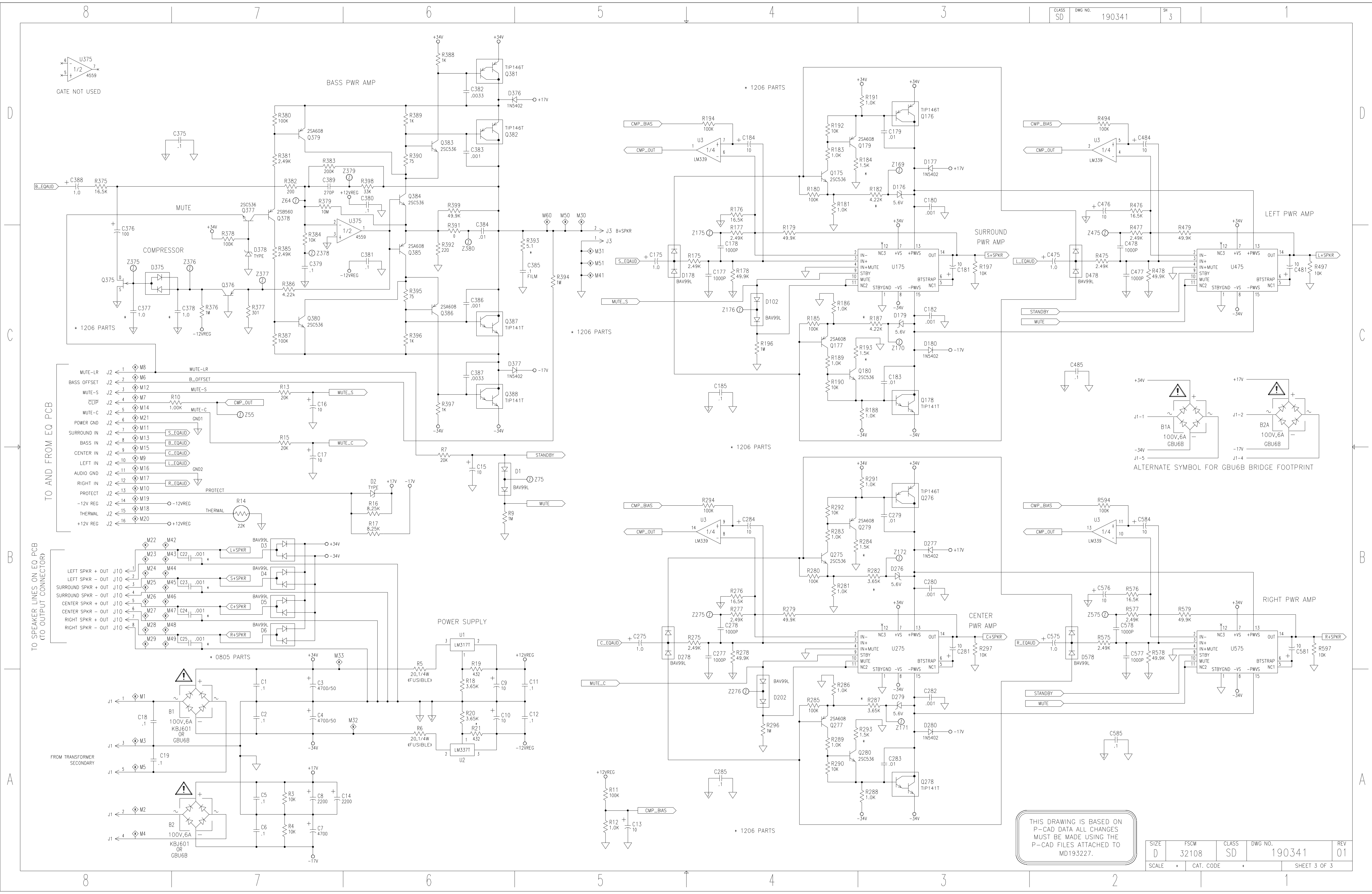

THIS DRAWING IS BASED ON P-CAD DATA ALL CHANGES MUST BE MADE USING THE P-CAD FILES ATTACHED TO MD193227.

SIZE	FSCM	CLASS	DWG NO.	REV
D	32108	SD	190341	01
SCALE	CAT. CODE	SHEET 3 OF 3		