

Companion[®] 3 Series II Multimedia Speaker System



Product Description

The Companion 3 series II multimedia speaker system is a stereo system designed to be used as a computer sound system. It can be used with any analog audio source. It has a bass module with a 6.5 inch dual voice coil woofer in a slot ported design. The two satellite speakers connect to the bass module and are mounted to speaker stands. The speakers can be placed on a desk or other surface when removed from the stands. A wired remote control pod is used to control volume and mute/un-mute functions. The system also has a second input and a stereo headphone output on the control pod.

Contents

Safety Information	3
Electrostatic Discharge Sensitive (ESDS) Device Handling	3
Specifications	4
Part List Notes	5
Figure 1. Bass Module Assembly Exploded View	56
Bass Module Assembly Parts List	6
Figure 2. Amplifier Module Assembly Exploded View	7
Amplifier Module Assembly Parts list	7
Figure 3. Packing Exploded Veiw	8
Packing Parts List	8
Electrical Parts List	9-19
Main PCB Assembly Parts List	9-17
Power Supply PCB Assembly Parts List	18-19
Disassembly Procedures	20-22
Test Procedures	23-25
Theory of Operation	26-28
Revision History	29

Warranty

The Bose® Companion® 3 series II MultiMedia Speaker System is covered by a 1-year, transferable limited warranty.

Proprietary Information

THIS DOCUMENT CONTAINS PROPRIETARY INFORMATION OF BOSE CORPORATION WHICH IS BEING FURNISHED ONLY FOR THE PURPOSE OF SERVICING THE IDENTIFIED BOSE PRODUCT BY AN AUTHORIZED BOSE SERVICE CENTER OR OWNER OF THE BOSE PRODUCT, AND SHALL NOT BE REPRODUCED OR USED FOR ANY OTHER PURPOSE.

Caution: The Companion 3 series II MultiMedia Speaker System contains no user serviceable parts. To prevent warranty infractions, refer servicing to warranty service centers or factory service.

Safety Information



1. Parts that have special safety characteristics are identified by the  symbol on the schematics or by special notes on the parts list. Use only replacement parts that have critical characteristics recommended by the manufacturer.

2. Make leakage current or resistance measurements to determine that exposed parts are acceptably insulated from the supply circuit before returning the unit to the customer. Use the following checks to perform these measurements:

A. Leakage Current Hot Check- With the unit completely reassembled, plug the AC line cord directly into a 120V AC outlet. (Do not use an isolation transformer during this test). Use a leakage current tester or a metering system that complies with the American National Standards Institute (ANSI) C101.1 "Leakage Current for Appliances" and the Underwriters Laboratories (UL) 6500/IEC 60056 paragraph 9.1.1. With the unit AC switch first in the ON position and then in the OFF position, measure from a known earth ground (metal waterpipe, conduit, etc.) to all exposed metal parts of the unit (antennas, handle bracket, metal cabinet, screwheads, metallic overlays, control shafts, etc.) especially any exposed metal parts that offer an electrical return path to the chassis. Any current measured must not exceed 0.5 milliamp. Reverse the unit power cord plug in the AC outlet and repeat the test. ANY MEASUREMENTS NOT WITHIN THE LIMITS SPECIFIED HEREIN INDICATE A POTENTIAL SHOCK HAZARD THAT MUST BE ELIMINATED BEFORE RETURNING THE UNIT TO THE CUSTOMER.

B. Insulation Resistance Test Cold Check- (1) Unplug the power supply and connect a jumper wire between the two prongs of the plug. (2) Turn on the power switch of the unit. (3) Measure the resistance with an ohmmeter between the jumpered AC plug and each exposed metallic cabinet part on the unit. When testing 3 wire products, the resistance measured to the product enclosure should be between 2 and infinite MOhms. Also, the resistance measured to exposed input/output connectors should be between 4 and infinite MOhms. When testing 2 wire products, the resistance measured to exposed input/output connectors should be between 4 and infinite MOhms. If it is not within the limits specified, there is the possibility of a shock hazard, and the unit must be repaired and rechecked before it is returned to the customer.

Electrostatic Discharge Sensitive (ESDS) Device Handling

This unit contains ESDS devices. We recommend the following precautions when repairing, replacing or transporting ESDS devices:

- Perform work at an electrically grounded work station.
- Wear wrist straps that connect to the station or heel straps that connect to conductive floor mats.
- Avoid touching the leads or contacts of ESDS devices or PC boards even if properly grounded. Handle boards by the edges only.
- Transport or store ESDS devices in ESD protective bags, bins, or totes. Do not insert unprotected devices into materials such as plastic, polystyrene foam, clear plastic bags, bubble wrap or plastic trays.

Specifications

Mechanical

Dimensions:	Bass Module:	8 5/8 " H x 7 1/8" W x 14" D (21.8 x 18 x 35.56 cm)
	Satellite Speaker: (no stand)	2 1/2" H x 2 3/4" W x 2 3/8" D (6.14 x 6.86 x 6.03 cm)
	Control Pod:	2 1/2 " D x 1 1/8" H (6.35 x 2.79 cm)
Weight:	Bass Module:	14.65 lbs (6.64 kg) unpacked
	Satellite Speaker:	.75 lbs (0.34 kg) each
	Packaged System:	20.15 lbs (9.13 kg) packed
Finish:	Bass Module:	Scratch-resistant, satin-finish vinyl
	Satellites:	Painted polymer finish
Bass Box:		Slot ported
Bass Box Port Tuning:		45 Hz

Electrical

Power Rating:	USA/Canada:	115 VAC 50/60 Hz
	Japan:	100 VAC 50/60 Hz
	Euro:	230 VAC 50/60 Hz
Nominal System Bandwidth:		40 Hz to 15 kHz
Maximum SPL:		100 dB (A weighted) pink noise signal
Output:	Bass:	60 Watts
	Satellites:	18 Watts per channel

Part List Notes

1. This part is not normally available from Customer Service. Approval from the Field Service Manager is required before ordering.
2. The individual parts on the PCBs are listed in the Electrical Part list.
3.  This part is critical for safety purposes. Failure to use a substitute replacement with the same safety characteristics as the recommended replacement part might create shock, fire and/or other hazards.
4. The part number listed is an assembly part number. The individual parts of the assembly might not be available separately.
5. This part is referenced for informational purposes only. It is not stocked as a repair part. Refer to the next higher assembly for a replacement part.

Bass Module Assembly Exploded View

Item	Description	Part Number	Qty.	Note
1	BASS MODULE, ASSY, US/CANADA, 120V (Electrofoil Logo)	*300905-001	1	
	BASS MODULE, ASSY, EURO, 230V (Electrofoil Logo)	*300905-003	1	
	BASS MODULE, ASSY, JAPAN, 100V (Electrofoil Logo)	*300905-002	1	
	BASS MODULE, ASSY, US/CANADA, 120V (Padprint Logo)	*303939-112		
	BASS MODULE, ASSY, EURO, 230V (Padprint Logo)	*303939-122		
	BASS MODULE, ASSY, JAPAN, 100V (Padprint Logo)	*303939-132		
	(Complete bass module package, includes Amp Mod Assy)			
2	CLEAT, ABS	271817-001	1	5
3	SCREW, 4 x 1, THDF, FLHD, 82 DEG, PH	274151-16	3	
4	CLIP, SPRING, KNOB	262542	1	
5	KNOB, VOL CNTL, BLK	271860-001	1	
6	LABEL, I/O, US/CANADA, 120V	300954-001	1	
	LABEL, I/O, JAPAN, 100V	300954-002		
	LABEL, I/O, EURO, 230V	300954-003		
7	SCREW, TF, 4 x 3/4, PAN, PH, BLK	273556-12	5	
8	MOD ASSY, AMP, 120V	*307876-011	1	3 
	MOD ASSY, AMP, 220V, EURO	*307876-033	1	
	MOD ASSY, AMP, 100V JAPAN	*307876-022	1	
-	XFORMER, TORROID, 105W, 15VDC, 7A	271818-001		
	TRANSFORMER, TOROID, 100V, 60Hz	N/A		
	TRANSFORMER, TOROID, 230V, 50Hz	277613-001		

*Capacitor C7 on the new power supply board may need to be replaced, see Service Bulletin 271885-B4

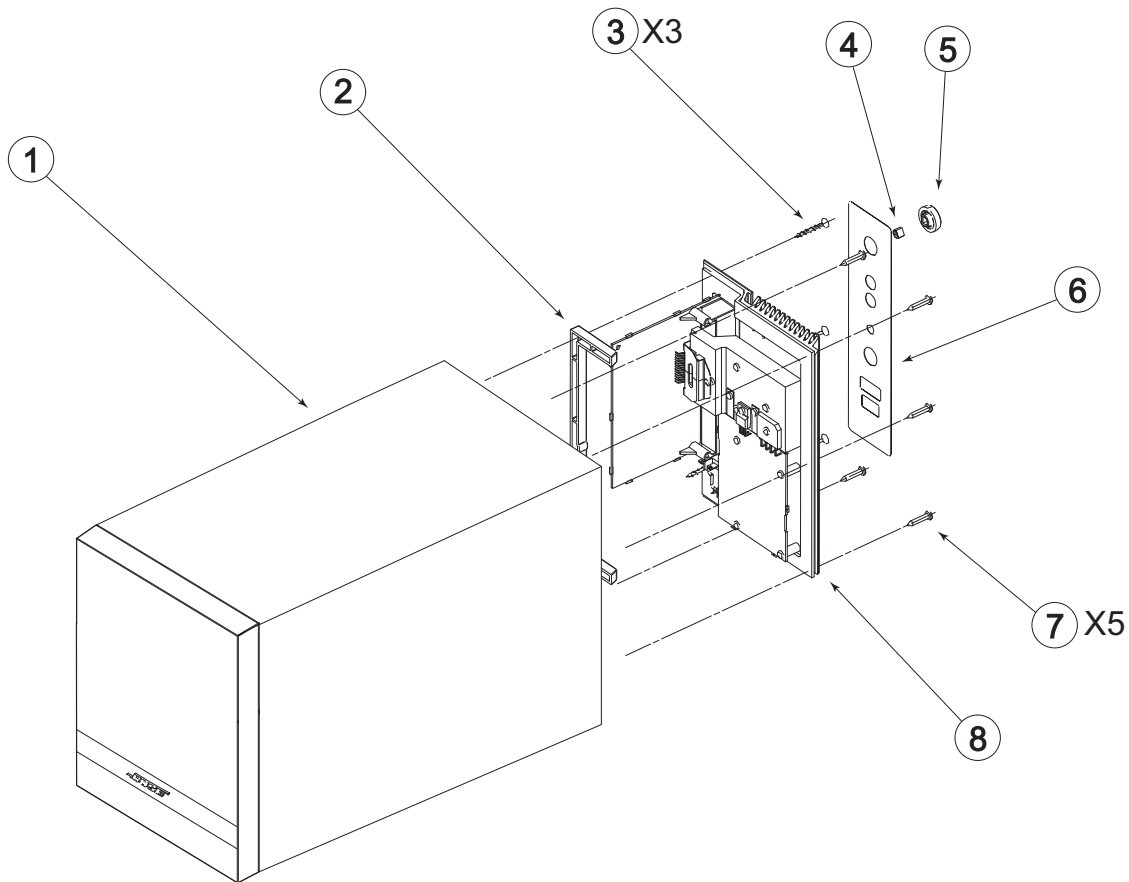

Figure 1. Bass Module Assembly Exploded View

Amplifier Module Assembly

Item	Description	Part Number	Qty.	Note
1	PCB ASSY, MAIN	277574-001	1	5
2	BRACKET, METAL, IC	271859	1	5
3	HEATSINK, EXTRUDED, COMP 3	271856	1	5
4	CLIP, THERMAL, THERMISTOR	272964-001	1	5
5	HEAT SPREADER, ALUM	279844-001	1	5
6	SCREW, TAPP, 6-13x.625, PAN, XRC/S	172783-10	4	
7	CONN, SWITCH, POWER, 3P	273115-001	5	
8	PCB ASSY, PS, 120V, US	*307872-011	1	4
	PCB ASSY, PS, 100V, JAPAN	*307872-022	1	4
	PCB ASSY, PS, 220V, EURO	*307872-033	1	4

*Capacitor C7 on the new power supply board may need to be replaced, see Service Bulletin 271885-B4

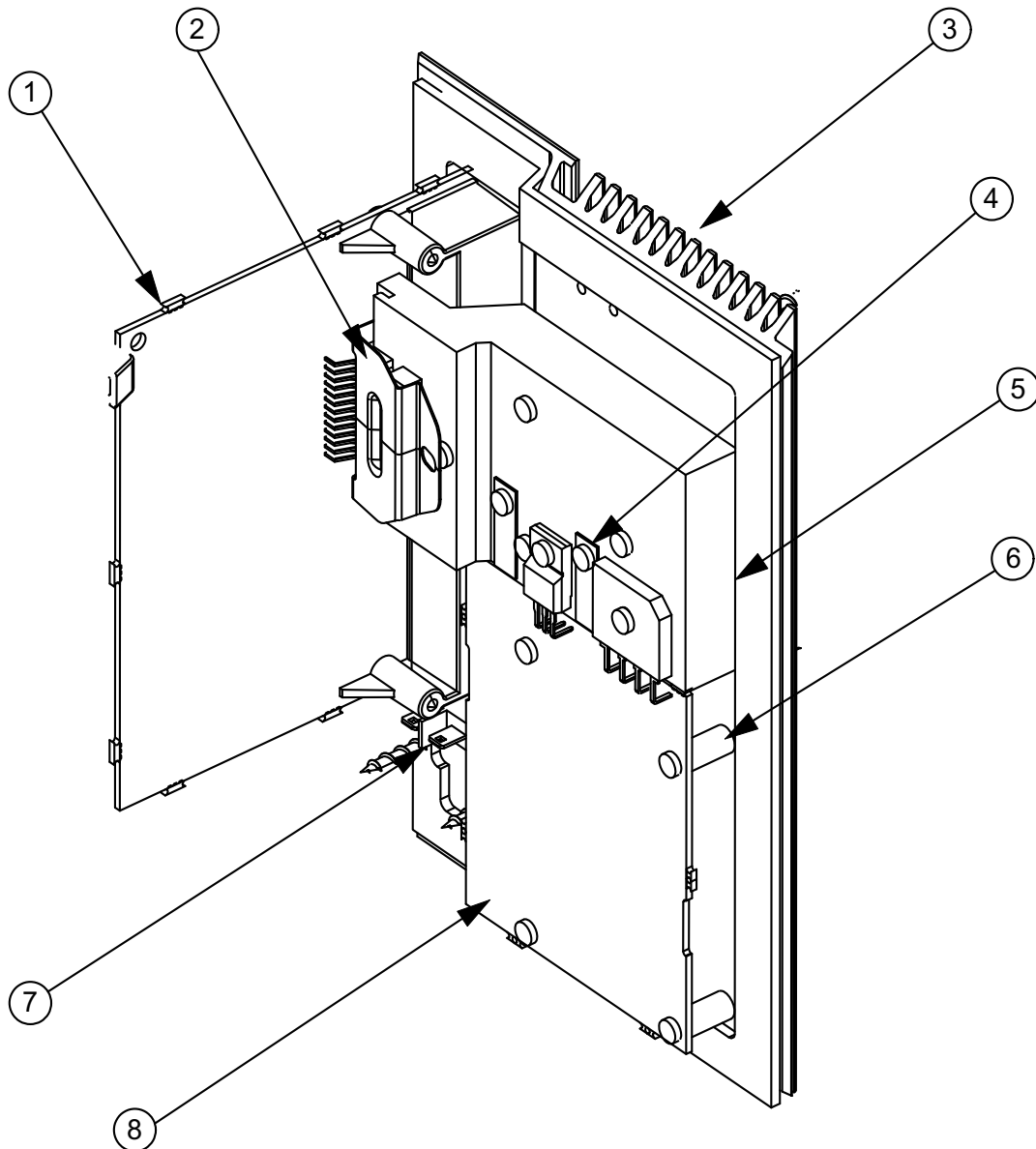

Figure 2. Amplifier Module Assembly

Packaging Part List

Item Number	Description	Part Number	Qty.	Notes
1	FEET, CLEAR SATELLITE	178321-04	2	
2	FEET, RUBBER, BRACKET	260465	1	
3	PACKING EPS, FILLER (includes both top and bottom filler)	300908-001	1	
4	CONTROL POD, (NON-REPAIRABLE)	307874-002	1	
5	CABLE, INPUT, 3.5MM, 6FT, BLK	271994-001	1	
6	LINE CORD, 100V, BLK, JAPAN LINE CORD, 120V, BLK, US/CANADA LINE CORD, 220V, BLK, EURO LINE CORD, 230V, BLK, UK LINE CORD, 240V, BLK, AUS	264514-001 262814-001 148203 134725 284243-001	1	3 ⚠
7	BASS MODULE, ASSY, US/CANADA, 120V (Electrofoil Logo) BASS MODULE, ASSY, EURO, 230V (Electrofoil Logo) BASS MODULE, ASSY, JAPAN, 100V (Electrofoil Logo) BASS MODULE, ASSY, US/CANADA, 120V (Padprint Logo) BASS MODULE, ASSY, EURO, 230V (Padprint Logo) BASS MODULE, ASSY, JAPAN, 100V (Padprint Logo) (Complete bass module package, includes Amp Mod Assy)	*300905-001 *300905-003 *300905-002 *303939-112 *303939-122 *303939-132	1	
8	SAT, ASSY (Electrofoil Logo) SAT, ASSY (Padprint Logo) (single array, includes speaker stand)	300766-001 303938-002	2	
9	OWNERS GUIDE, 3 LANG, US/CANADA OWNERS GUIDE, 5 LANG, EURO OWNERS GUIDE, 5 LANG, AP	296583 296584 299450	1	
10	CARTON, RSC, PRINTED	300911-001	1	
-	CARTON KIT	300911-001K	1	

*Capacitor C7 on the new power supply board may need to be replaced, see Service Bulletin 271885-B4

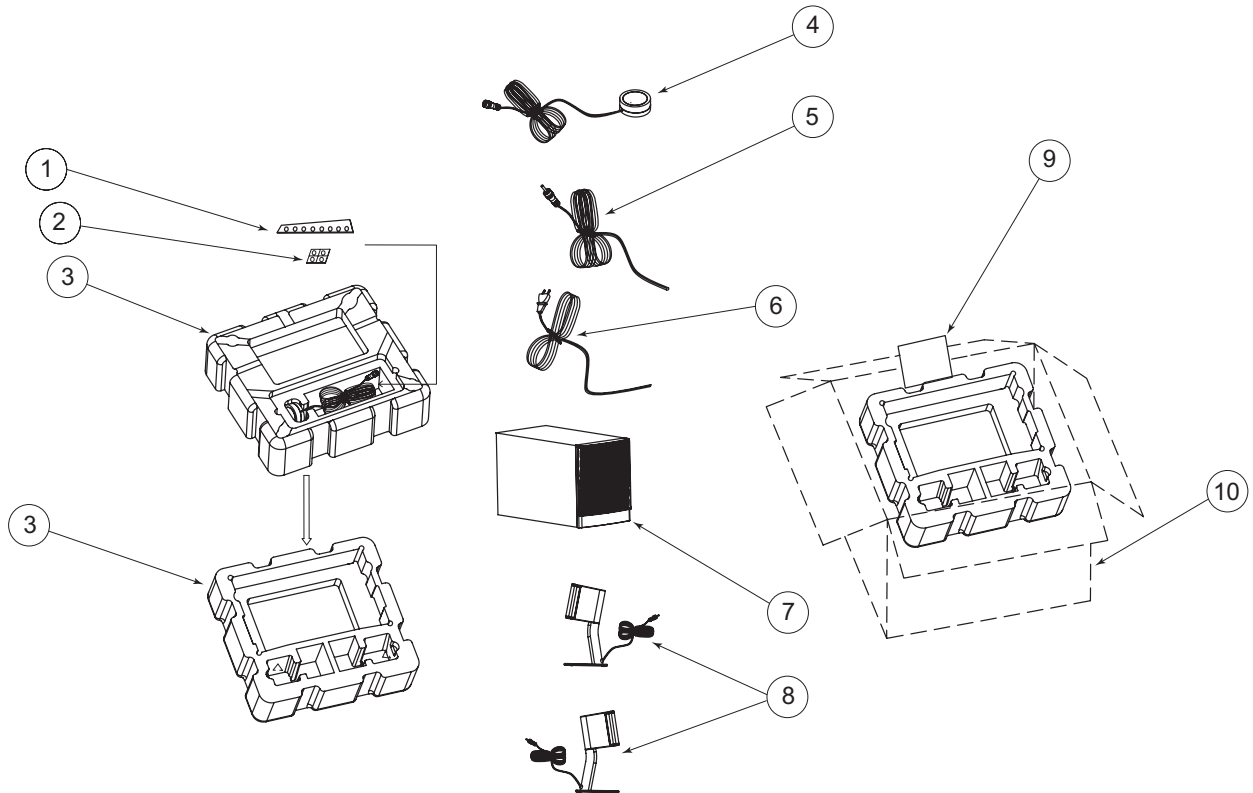

Figure 3. Packaging Exploded View

ELECTRICAL PARTS LIST

Main PCB Assembly

Resistors

Reference Designator	Description	Part Number	Note
R101	1.21K, 0805, 1/10W, 1%	133625-1211	
R102	1.30K, 0805, 1/10W, 1%	133625-1301	
R103	9.53K, 0805, 1/10W, 1%	133625-9531	
R104	10.0K, 0805, 1/10W, 1%	133625-1002	
R105	127K, 0805, 1/10W, 1%	133625-1273	
R106	127K, 0805, 1/10W, 1%	133625-1273	
R107	10.0K, 0805, 1/10W, 1%	133625-1002	
R108	10.0K, 0805, 1/10W, 1%	133625-1002	
R109	2.00K, 0805, 1/10W, 1%	133625-2001	
R110	10.0K, 0805, 1/10W, 1%	133625-1002	
R111	10.0K, 0805, 1/10W, 1%	133625-1002	
R125	2.55K, 0805, 1/10W, 1%	133625-2551	
R126	200K, 0805, 1/10W, 1%	133625-2003	
R127	47.5K, 0805, 1/10W, 1%	133625-4752	
R128	1.10K, 0805, 1/10W, 1%	133625-1101	
R129	21.5K, 0805, 1/10W, 1%	133625-2152	
R130	330 OHM, 0805, 1/10W, 1%	133625-3300	
R131	6.81K, 0805, 1/10W, 1%	133625-6811	
R132	17.4K, 0805, 1/10W, 1%	133625-1742	
R133	1.62K, 0805, 1/10W, 1%	133625-1621	
R134	2.00K, 0805, 1/10W, 1%	133625-2001	
R135	1.00K, 0805, 1/10W, 1%	133625-1001	
R136	1.82K, 0805, 1/10W, 1%	133625-1821	
R137	10.0K, 0805, 1/10W, 1%	133625-1002	
R138	2.00K, 0805, 1/10W, 1%	133625-2001	
R139	1.50K, 0805, 1/10W, 1%	133625-1501	
R140	1.50K, 0805, 1/10W, 1%	133625-1501	
R201	1.21K, 0805, 1/10W, 1%	133625-1211	
R202	1.30K, 0805, 1/10W, 1%	133625-1301	
R203	9.53K, 0805, 1/10W, 1%	133625-9531	
R204	127K, 0805, 1/10W, 1%	133625-1273	
R205	10.0K, 0805, 1/10W, 1%	133625-1002	
R206	127K, 0805, 1/10W, 1%	133625-1273	
R207	10.0K, 0805, 1/10W, 1%	133625-1002	
R208	10.0K, 0805, 1/10W, 1%	133625-1002	
R209	10.0K, 0805, 1/10W, 1%	133625-1002	
R210	10.0K, 0805, 1/10W, 1%	133625-1002	
R211	2.00K, 0805, 1/10W, 1%	133625-2001	
R225	100K, 0805, 1/10W, 1%	133625-1003	
R226	100K, 0805, 1/10W, 1%	133625-1003	
R227	JUMPER, CHIP, 0805	133627	
R229	2.55K, 0805, 1/10W, 1%	133625-2551	
R230	200K, 0805, 1/10W, 1%	133625-2003	
R231	47.5K, 0805, 1/10W, 1%	133625-4752	
R232	1.10K, 0805, 1/10W, 1%	133625-1101	

ELECTRICAL PARTS LIST





Main PCB Assembly Resistors

Reference Designator	Description	Part Number	Note
R233	21.5K, 0805, 1/10W, 1%	133625-2152	
R234	330 OHM, 0805, 1/10W, 1%	133625-3300	
R235	6.81K, 0805, 1/10W, 1%	133625-6811	
R236	17.4K, 0805, 1/10W, 1%	133625-1742	
R237	1.62K, 0805, 1/10W, 1%	133625-1621	
R238	2.00K, 0805, 1/10W, 1%	133625-2001	
R239	1.00K, 0805, 1/10W, 1%	133625-1001	
R240	1.82K, 0805, 1/10W, 1%	133625-1821	
R241	10.0K, 0805, 1/10W, 1%	133625-1002	
R242	2.00K, 0805, 1/10W, 1%	133625-2001	
R243	1.50K, 0805, 1/10W, 1%	133625-1501	
R244	1.50K, 0805, 1/10W, 1%	133625-1501	
R301	100 OHM, 0805, 1/10W, 1%	133625-1000	
R302	100 OHM, 0805, 1/10W, 1%	133625-1000	
R305	10.0K, 0805, 1/10W, 1%	133625-1002	
R306	10.0K, 0805, 1/10W, 1%	133625-1002	
R307	1.2 OHMS, 2512, 1W, 5%	181895-1R20	
R308	1K, 2512, 1W, 5%	181895-1001	
R309	100 OHM, 0805, 1/10W, 1%	133625-1000	
R310	100 OHM, 0805, 1/10W, 1%	133625-1000	
R311	JUMPER, CHIP, 0805	133627	
R312	JUMPER, CHIP, 0805	133627	
R314	1.00K, 0805, 1/10W, 1%	133625-1001	
R315	1.00K, 0805, 1/10W, 1%	133625-1001	
R316	249 OHM, 0805, 1/10W, 1%	133625-2490	
R317	249 OHM, 0805, 1/10W, 1%	133625-2490	
R318	100K, 0805, 1/10W, 1%	133625-1003	
R319	249 OHM, 0805, 1/10W, 1%	133625-2490	
R320	1.00K, 0805, 1/10W, 1%	133625-1001	
R323	487K, 0805, 1/10W, 1%	133625-4873	
R324	12.1K, 0805, 1/10W, 1%	133625-1212	
R325	12.1K, 0805, 1/10W, 1%	133625-1212	
R327	JUMPER, CHIP, 0805	133627	
R328	JUMPER, CHIP, 0805	133627	
R329	16.2K, 0805, 1/10W, 1%	133625-1622	
R330	78.7K, 0805, 1/10W, 1%	133625-7872	
R331	2.00K, 0805, 1/10W, 1%	133625-2001	
R334	100K, 0805, 1/10W, 1%	133625-1003	
R335	100K, 0805, 1/10W, 1%	133625-1003	
R336	10 OHM, 2512, 1W, 5%	181895-10R0	
R337	162 OHM, 0805, 1/10W, 1%	133625-1620	
R338	14.0K, 0805, 1/10W, 1%	133625-1402	
R339	1.00K, 0805, 1/10W, 1%	133625-1001	
R340	10.0K, 0805, 1/10W, 1%	133625-1002	
R347	2.00K, 0805, 1/10W, 1%	133625-2001	

ELECTRICAL PARTS LIST

Main PCB Assembly

Resistors

Reference Designator	Description	Part Number	Note
R348	2.00K, 0805, 1/10W, 1%	133625-2001	
R349	JUMPER, CHIP, 0805	133627	
R350	JUMPER, CHIP, 0805	133627	
R351	100OHM, 0805, 1/10W, 1%	133625-1000	
R352	1.00K, 0805, 1/10W, 1%	133625-1001	
R353	1.00K, 0805, 1/10W, 1%	133625-1001	
R354	1.00K, 0805, 1/10W, 1%	133625-1001	
R355	1.00K, 0805, 1/10W, 1%	133625-1001	
R356	499K, 0805, 1/10W, 1%	133625-4993	
R357	10.0K, 0805, 1/10W, 1%	133625-1002	
R358	1.1 OHM, SMD, FUSE, 1/10W, 5%	192349-1R1A	3 
R359	1.1 OHM, SMD, FUSE, 1/10W, 5%	192349-1R1A	3 
R360	1.1 OHM, SMD, FUSE, 1/10W, 5%	192349-1R1A	3 
R361	1.1 OHM, SMD, FUSE, 1/10W, 5%	192349-1R1A	3 
R362	JUMPER, CHIP, 0805	133627	
R401	100K, 0805, 1/10W, 1%	133625-1003	
R402	10.0K, 0805, 1/10W, 1%	133625-1002	
R403	221 OHM, 0805, 1/10W, 1%	133625-2210	
R404	10.0K, 0805, 1/10W, 1%	133625-1002	
R405	1.00K, 0805, 1/10W, 1%	133625-1001	
R406	1.00K, 0805, 1/10W, 1%	133625-1001	
R407	1.00K, 0805, 1/10W, 1%	133625-1001	
R408	1.00K, 0805, 1/10W, 1%	133625-1001	
R409	5.90K, 0805, 1/10W, 1%	133625-5901	
R410	5.90K, 0805, 1/10W, 1%	133625-5901	
R950	2.55K, 0805, 1/10W, 1%	133625-2551	
R951	4.12K, 0805, 1/10W, 1%	133625-4121	
R952	1.0M, 0805, 1/10W, 1%	133625-1004	
R953	10.0K, 0805, 1/10W, 1%	133625-1002	
R954	750 OHM, 0805, 1/10W, 1%	133625-7500	
R956	88.7K, 0805, 1/10W, 1%	133625-8872	
R957	1.21K, 0805, 1/10W, 1%	133625-1211	
R958	10.0K, 0805, 1/10W, 1%	133625-1002	
R959	1.00K, 0805, 1/10W, 1%	133625-1001	
R960	36.5K, 0805, 1/10W, 1%	133625-3652	
R961	36.5K, 0805, 1/10W, 1%	133625-3652	
R962	1.0M, 0805, 1/10W, 1%	133625-1004	
R963	26.7K, 0805, 1/10W, 1%	133625-2672	
R964	750 OHM, 0805, 1/10W, 1%	133625-7500	
R965	15.4K, 0805, 1/10W, 1%	133625-1542	
R966	121K, 0805, 1/10W, 1%	133625-1213	
R967	1.00K, 0805, 1/10W, 1%	133625-1001	
R968	4.99K, 0805, 1/10W, 1%	133625-4991	

ELECTRICAL PARTS LIST

Main PCB Assembly

Resistors

Reference Designator	Description	Part Number	Note
R969	JUMPER, CHIP, 0805	133627	
R970	20.0K, 0805, 1/10W, 1%	133625-2002	
R971	10.0K, 0805, 1/10W, 1%	133625-1002	
R972	49.9K, 0805, 1/10W, 1%	133625-4992	
R973	1.21K, 0805, 1/10W, 1%	133625-1211	
R974	1.00K, 0805, 1/10W, 1%	133625-1001	
R975	10.0K, 0805, 1/10W, 1%	133625-1002	
R976	5.90K, 0805, 1/10W, 1%	133625-5901	
R977	100 OHM, 0805, 1/10W, 1%	133625-1000	
R978	100K, 0805, 1/10W, 1%	133625-1003	
R979	10.0K, 0805, 1/10W, 1%	133625-1002	
R980	4.99K, 0805, 1/10W, 1%	133625-4991	
R981	100K, 0805, 1/10W, 1%	133625-1003	
R982	1.00K, 0805, 1/10W, 1%	133625-1001	
R983	1.00K, 0805, 1/10W, 1%	133625-1001	
R986	POTENTIOMETER, 10K, 1B, 20%	273741-001	
R987	1.54K, 0805, 1/10W, 1%	133625-1541	

ELECTRICAL PARTS LIST

Main PCB Assembly
Capacitors

Reference Designator	Description	Part Number	Note
C101	2.2uF, 1206, X7R, 10V, 20%	260361-2253	
C102	.0068uF, BOX, 85C, 100V, 5%	137127-682	
C103	.033uF, BOX, 85C, 63V, 5%	137127-333	
C104	1000pF, 0805, COG, 50V, 5%	133622-102	
C105	100 pF, 0805, COG, 50V, 5%	133622-101	
C110	68pF, 0603, COG, 50V, 5%	188454-680	
C111	68pF, 0603, COG, 50V, 5%	188454-680	
C112	68pF, 0603, COG, 50V, 5%	188454-680	
C125	.12uF, BOX, 85C, 50V, 5%	137127-124	
C126	.12uF, BOX, 85C, 50V, 5%	137127-124	
C127	.18uF, BOX, 85C, 50V, 5%	137127-184	
C128	.01uF, BOX, 85C, 100V, 5%	137127-103	
C129	.01uF, BOX, 85C, 100V, 5%	137127-103	
C130	.0015uF, BOX, 85C, 100V, 5%	137127-152	
C131	.0056uF, BOX, 85C, 100V, 5%	137127-562	
C132	.12uF, BOX, 85C, 50V, 5%	137127-124	
C133	.12uF, BOX, 85C, 50V, 5%	137127-124	
C134	1000pF, 0805, COG, 50V, 5%	133622-102	
C201	2.2uF, 1206, X7R, 10V, 20%	260361-2253	
C202	.0068uF, BOX, 85C, 100V, 5%	137127-682	
C203	.033uF, BOX, 85C, 63V, 5%	137127-333	
C204	100 pF, 0805, COG, 50V, 5%	133622-101	
C210	68pF, 0603, COG, 50V, 5%	188454-680	
C225	.12uF, BOX, 85C, 50V, 5%	137127-124	
C226	.12uF, BOX, 85C, 50V, 5%	137127-124	
C227	.18uF, BOX, 85C, 50V, 5%	137127-184	
C228	.01uF, BOX, 85C, 100V, 5%	137127-103	
C229	.01uF, BOX, 85C, 100V, 5%	137127-103	
C230	.0015uF, BOX, 85C, 100V, 5%	137127-152	
C231	.0056uF, BOX, 85C, 100V, 5%	137127-562	
C232	1000pF, 0805, COG, 50V, 5%	133622-102	
C233	.12uF, BOX, 85C, 50V, 5%	137127-124	
C234	.12uF, BOX, 85C, 50V, 5%	137127-124	
C235	.1uF, 0805, X7R, 25V, 10%	181264-104	
C236	10uF, EL, SMD, 105, 25V, 20%	255071-100E	
C238	10uF, EL, SMD, 105, 25V, 20%	255071-100E	
C239	.1uF, 0805, X7R, 25V, 10%	181264-104	
C240	68pF, 0603, COG, 50V, 5%	188454-680	
C241	68pF, 0603, COG, 50V, 5%	188454-680	
C301	100 pF, 0805, COG, 50V, 5%	133622-101	
C302	3300pF, 0805, X7R, 50V, 10%	133623-332	
C303	100 pF, 0805, COG, 50V, 5%	133622-101	
C305	3300pF, 0805, X7R, 50V, 10%	133623-332	
C306	1uF, EL, SMD, 105C, 50V, 20%	255071-1R0H	
C307	1uF, EL, SMD, 105C, 50V, 20%	255071-1R0H	

ELECTRICAL PARTS LIST

Main PCB Assembly
Capacitors (continued)

Reference Designator	Description	Part Number	Note
C307	1uF, EL, SMD, 105C, 50V, 20%	255071-1R0H	
C308	100 pF, 0805, COG, 50V, 5%	133622-101	
C309	.015uF, 0805, X7R, 50V, 10%	133623-153	
C310	100 pF, 0805, COG, 50V, 5%	133622-101	
C311	10uF, EL, SMD, 105C, 25V, 20%	255071-100E	
C312	100 pF, 0805, COG, 50V, 5%	133622-101	
C313	100uF, EL, SMD, 105C, 25V, 20%	255071-101E	
C314	10uF, EL, SMD, 105C, 25V, 20%	255071-100E	
C315	10uF, EL, SMD, 105C, 25V, 20%	255071-100E	
C316	.1uF, 0805, X7R, 25V, 10%	181264-104	
C317	.1uF, 0805, X7R, 25V, 10%	181264-104	
C318	.1uF, 0805, X7R, 25V, 10%	181264-104	
C319	.1uF, 0805, X7R, 25V, 10%	181264-104	
C320	.47uF, 0805, X7R, 16V, 5%	196995-474	
C321	.015uF, BOX, 85C, 100V, 5%	137127-153	
C322	47uF, EL, SMD, 105, 25V, 20%	255071-470E	
C324	.15uF, BOX, 85C, 50V, 5%	137127-154	
C325	0.1uF, 0805, X7R, 50V, 10%	133623-104	
C326	.01uF, 0805, X7R, 50V, 10%	133623-103	
C327	.1uF, BOX, 85C, 50V, 5%	137127-104	
C328	.01uF, 0805, X7R, 50V, 10%	133623-103	
C329	.1uF, BOX, 85C, 50V, 5%	137127-104	
C330	.01uF, 0805, X7R, 50V, 10%	133623-103	
C331	.01uF, 0805, X7R, 50V, 10%	133623-103	
C332	1000pF, 0805, COG, 50V, 5%	133622-102	
C333	1000pF, 0805, X7R, 50V, 10%	133623-102	
C334	1000pF, 0805, X7R, 50V, 10%	133623-102	
C335	1000pF, 0805, X7R, 50V, 10%	133623-102	
C336	1000pF, 0805, X7R, 50V, 10%	133623-102	
C337	10uF, EL, SMD, 105C, 25V, 20%	255071-100E	
C338	1000pF, 0805, COG, 50V, 5%	133622-102	
C339	1000pF, 0805, COG, 50V, 5%	133622-102	
C340	1000pF, 0805, COG, 50V, 5%	133622-102	
C341	1000pF, 0805, COG, 50V, 5%	133622-102	
C342	47uF, EL, SMD, 105C, 25V, 20%	255071-470E	
C343	1000pF, 0805, COG, 50V, 5%	133622-102	
C348	.01uF, 0805, X7R, 50V, 10%	133623-103	
C349	.01uF, 0805, X7R, 50V, 10%	133623-103	
C350	.01uF, 0805, X7R, 50V, 10%	133623-103	
C351	.01uF, 0805, X7R, 50V, 10%	133623-103	
C352	68pF, 0603, COG, 50V, 5%	188454-680	
C353	68pF, 0603, COG, 50V, 5%	188454-680	
C354	68pF, 0603, COG, 50V, 5%	188454-680	
C355	68pF, 0603, COG, 50V, 5%	188454-680	
C360	.01uF, 0805, X7R, 50V, 10%	133623-103	

ELECTRICAL PARTS LIST

Main PCB Assembly
Capacitors (continued)

Reference Designator	Description	Part Number	Note
C401	10uF, EL, SMD, 105C, 25V, 20%	255071-100E	
C402	.01uF, 0805, X7R, 50V, 10%	133623-103	
C403	.01uF, 0805, X7R, 50V, 10%	133623-103	
C404	1000pF, 0805, COG, 50V, 5%	133622-102	
C950	10uF, EL, SMD, 105C, 25V, 20%	255071-100E	
C951	68pF, 0603, COG, 50V, 5%	188454-680	
C952	68pF, 0603, COG, 50V, 5%	188454-680	
C953	.12uF, BOX, 85C, 50V, 5%	137127-124	
C954	.12uF, BOX, 85C, 50V, 5%	137127-124	
C955	10uF, EL, SMD, 105, 25V, 20%	255071-100E	
C956	.01uF, BOX, 85C, 100V, 5%	137127-103	
C957	10uF, EL, SMD, 105, 25V, 20%	255071-100E	
C959	1000pF, 0805, COG, 50V, 5%	133622-102	
C960	.12uF, BOX, 85C, 50V, 5%	137127-124	
C961	.12uF, BOX, 85C, 50V, 5%	137127-124	
C962	.0015uF, BOX, 85C, 100V, 5%	137127-152	
C963	1000pF, 0805, COG, 50V, 5%	133622-102	
C964	1000pF, 0805, COG, 50V, 5%	133622-102	
C965	1000pF, 0805, COG, 50V, 5%	133622-102	
C966	1000pF, 0805, COG, 50V, 5%	133622-102	
C968	.01uF, 0805, X7R, 50V, 10%	133623-103	
C969	10uF, EL, SMD, 105C, 25V, 20%	255071-100E	
C970	1uF, EL, SMD, 105C, 50V, 20%	255071-1R0H	
C971	.47uF, BOX, 85C, 50V, 5%	137127-474	
C977	68pF, 0603, COG, 50V, 5%	188454-680	
C980	68pF, 0603, COG, 50V, 5%	188454-680	
C983	68pF, 0603, COG, 50V, 5%	188454-680	
C988	68pF, 0603, COG, 50V, 5%	188454-680	

Inductors

Reference Designator	Description	Part Number	Note
L301	330 OHM, BEAD, FERRITE, 0805, 1.5A	267539-331	

Diodes

Reference Designator	Description	Part Number	Note
D301	SOT-23, BAV 99	147239	
D302	SOT-23, BAV 99	147239	
D303	SOT-23, BAV 99	147239	
D304	SOT-23, BAV 99	147239	
D305	SOT-23, BAV 99	147239	
D306	SOT-23, BAV 99	147239	

ELECTRICAL PARTS LIST

Main PCB Assembly
Diodes (continued)

Reference Designator	Description	Part Number	Note
D401	DUAL, SOT-23, BAW56	180738	
D402	DUAL, SOT-23, BAW56	180738	
D403	SOT-23, BAV 99	147239	
D951	SOT-23, BAV 70	147249	
D952	SOT-23, BAV 99	147239	
D954	DUAL, SOT-23, BAW56	180738	
D955	SOT-23, BAV 99	147239	
ZR301	ZEN,SOD-123, .5W, 10V, 5%	174265-5240	

Transistors

Reference Designator	Description	Part Number	Note
Q303	NPN, 1.3W, SOT-223	258416-001	
Q304	BPLR, P, 40V, 200mA, SOT23	148596	
Q305	BPLR, N, 40V, 200mA, SOT23	146819	
Q306	BPLR, P, 40V, 200mA, SOT23	148596	
Q307	BPLR, P, 40V, 200mA, SOT23	148596	
Q308	BPLR, N, 40V, 200mA, SOT23	146819	
Q309	BPLR, N, 40V, 200mA, SOT23	146819	
Q401	BPLR, N, 40V, 200mA, SOT23	146819	
Q402	BPLR, P, 40V, 200mA, SOT23	148596	
Q403	BPLR, P, 40V, 200mA, SOT23	148596	
Q950	BPLR, N, 40V, 200mA, SOT23	146819	
Q951	BPLR, P, 40V, 200mA, SOT23	148596	
Q952	BPLR, P, 40V, 200mA, SOT23	148596	
Q953	BPLR, N, 40V, 200mA, SOT23	146819	
Q954	BPLR, P, 40V, 200mA, SOT23	148596	

Integrated Circuits

Reference Designator	Description	Part Number	Note
U3	IC, 0P AMP QUAD, SOIC-14, NJM2059	187472	
U102	IC, 0P AMP QUAD, SOIC-14, NJM2059	187472	
U125	IC, 0P AMP QUAD, SOIC-14, NJM2059	187472	
U201	IC, 0P AMP QUAD, SOIC-14, NJM2059	187472	
U301	IC, POWER AMP, 4x45W, 25-PIN, TDA7560	271833-001	
U401	IC, TRANS, DUAL, SOIC-16, NJM13700	188650-001	
U950	IC, TRANS, DUAL, SOIC-16, NJM13700	188650-001	
U951	IC, 0P AMP QUAD, SOIC-14, NJM2059	187472	





ELECTRICAL PARTS LIST

Main PCB Assembly
Miscellaneous

Reference Designator	Description	Part Number	Note
J301	CONN, HEADER, 3 POS, .156	133220-03	
J302	CONN, JACK PHONE, 3.5MM	269841-001	
J305	CONN, HEADER, INLINE, PCB MNT, 4P	133220-04	
J307	CONN, RCA, DUAL, PC MOUNT	272376-001	
J308	CONN, MINI DIN, R/A, 9-PIN	273227-001	

ELECTRICAL PARTS LIST

Power Supply PCB Assembly Resistors

Reference Designator	Description	Part Number	Note
R01	10.0 OHM, 0805, 1/10W, 1%	133625-10R0	
R02	10.0 OHM, 0805, 1/10W, 1%	133625-10R0	
R03	10.0 OHM, 0805, 1/10W, 1%	133625-10R0	
R04	10.0 OHM, 0805, 1/10W, 1%	133625-10R0	
R05	2.00K, 0805, 1/10W, 1%	133625-2001	
R06	10.0 OHM, 0805, 1/10W, 1%	133625-10R0	
R07	412 OHMS, 0805, 1/10W, 1%	133625-4120	
R08	JUMPER, CHIP, 0805	133627	
R09	412 OHMS, 0805, 1/10W, 1%	133625-4120	
R10	JUMPER, CHIP, 0805	133627	
R11	10.0 OHM, 0805, 1/10W, 1%	133625-10R0	
RT1	22K, THERMISTOR, RADIAL, 1/4W, 5%	177557	3 
RT2	22K, THERMISTOR, RADIAL, 1/4W, 5%	177557	3 
VR1	VARISTOR, MET OX, 275V, 140JOULE, US	273545-001	3 
VR1	VARISTOR, MET OX, 300V, 140JOULE, EURO	273545-002	3 
VR1	VARISTOR, MET OX, 175V, 140JOULE, JAPAN	273545-003	3 

Capacitors

Reference Designator	Description	Part Number	Note
C1	1.0uF, BOX, 85, 100V, 5%	137127-105	
C2	.22uF, 0805, X7R, 25V, 10%	181264-224	
C3	.047uF, 0805, X7R, 50V, 10%	133623-473	
C4	.1uF, 0805, X7R, 10%, 25V	181264-104	
C5	.1uF, 0805, X7R, 10%, 25V	181264-104	
C7	.033F, EL, AL, 25V, 4T, US	260693-3331E	
C7	.039F, EL, AL, 25V, 20% EURO	260693-3931E	
C7	.039F, EL, AL, 25V, 20%, JAPAN	260693-3931E	
C8	.22uF, FILM, X2, 275VAC, 15MM	268166-224B	

Inductors

Reference Designator	Description	Part Number	Note
L1	CHOKE, COMMON MODE, WITH HEADER	277667-001	

ELECTRICAL PARTS LIST

Power Supply PCB Assembly





Diodes

Reference Designator	Description	Part Number	Note
BR1	RECTIFIER, BRIDGE, 8A, 400V	260684-400	
D1	13V, ZEN, SOD-123, .5W, 5%	174265-5243	
D2	SOT-23, BAV 99	147239	

Transistors

Reference Designator	Description	Part Number	Note
Q1	BPLR, P, 40V, 200mA, SOT23	148596	
Q2	BPLR, P, 40V, 200mA, SOT23	148596	
Q3	MFET, N, 55V, TO-220FP	257359-001	
Q4	BPLR, P, 40V, 200mA, SOT23	148596	
Q5	BPLR, P, 40V, 200mA, SOT23	148596	

Miscellaneous

Reference Designator	Description	Part Number	Note
F1	FUSE, 4.0A, 125V, .60X.19, SLOBLO, US FUSE, 3.15A, 250V, 5.5X21mm, SLO-BLO, US	135677-12 298780-3150	3 
F1	FUSE, 2.0 AMPS, AXIAL, EURO	269855-02000	3 
F1	FUSE, 4.0A, 125V, .60X.19, SLOBLO, JAPAN	135677-12	3 
J1	CONN, HEADER, LOCKING, TOP ENTRY	193369-002	3 
J2	CONN, HEADER, 3.96mm, 7-pin	272385-07	3 
J3	CONN, HEADER, 3 POS, .156	133220-03	3 

Disassembly Procedures

Bass Module

1. Module Assembly Removal

1.1 Remove the knob from the unit.

1.2 Peel back the label and remove it.

Note: The label will become damaged once removed from the rear panel. A replacement label must be installed during reassembly.

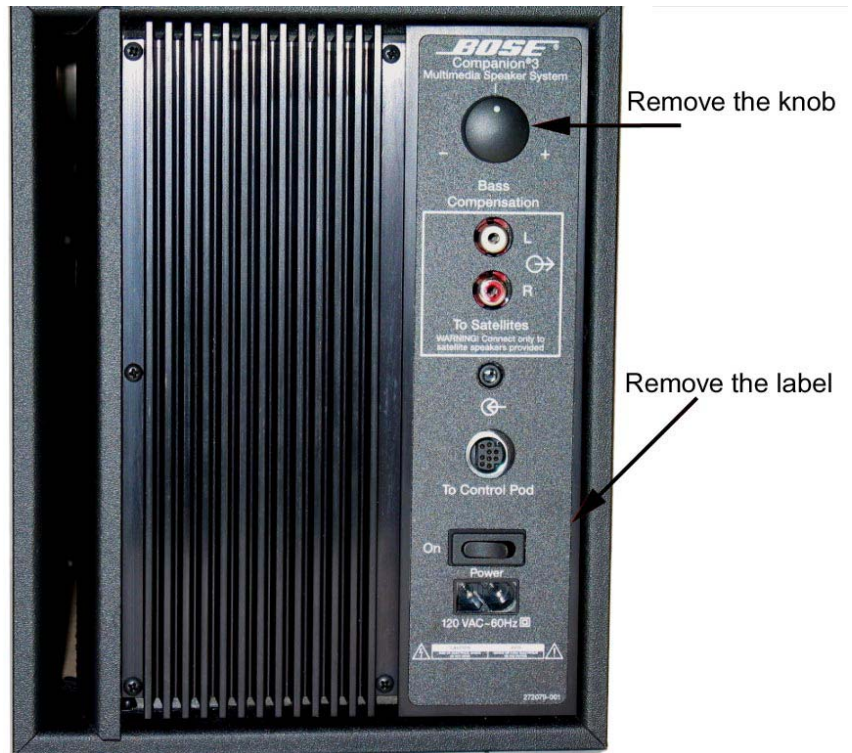

1.3 Remove the three silver Phillips-head screws located on the right hand side (under the label) and the five Phillips-head or T-15 Torx head screws around the heat sink fins.

1.4 Slide the electronic module back slightly.



Disassembly Procedures

Bass Module Cont.

1.5 Disconnect the two connectors shown and remove the module assembly.

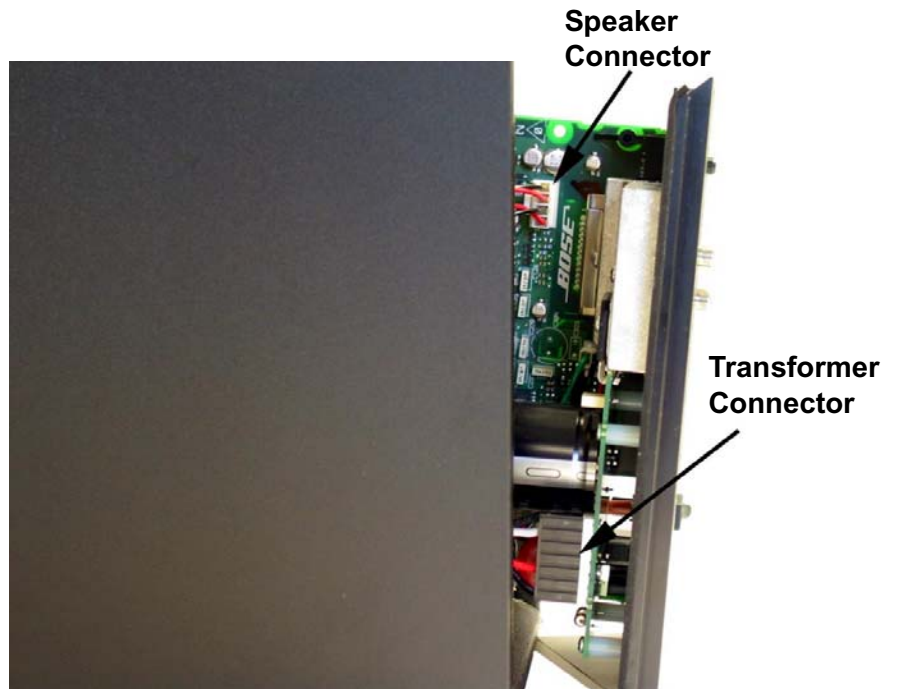

1.6 Disconnect the two connectors on the power supply PCB.

1.7 Remove the seven T-15 Torx screws shown, to remove the power supply PCB.

Note: The PCB is mounted on stand-offs which will become loose when removing the screws.

Note: The main PCB is glued to the heat sink assembly however it can be repaired without having to remove it.

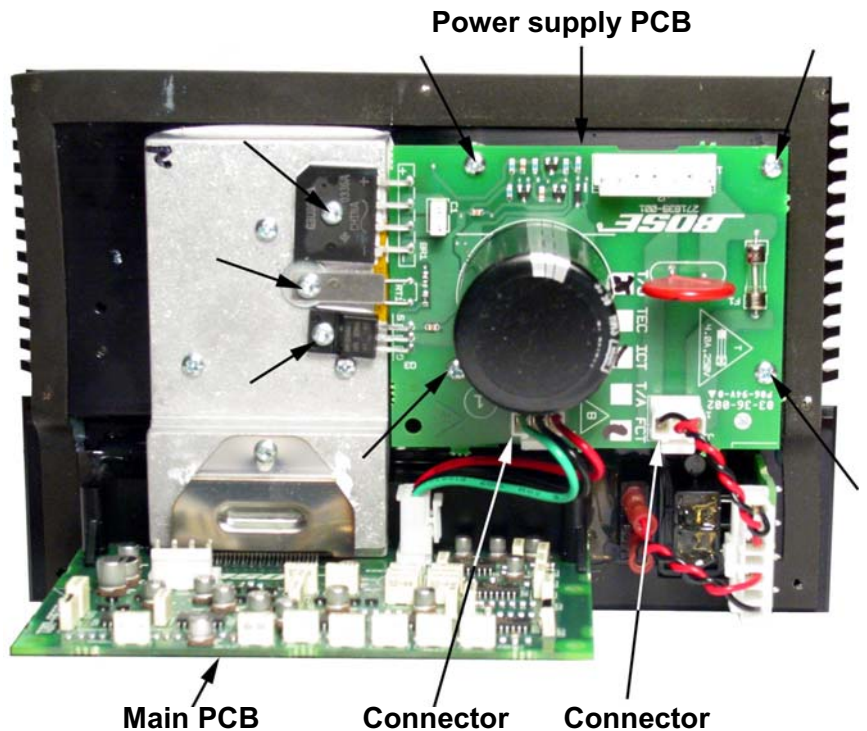

Disassembly Procedures

Bass Module Cont.

2. Power Transformer Removal

2.1 Remove the module assembly, perform procedure 1.

2.2 Remove the bolt at the center of the power transformer.

2.3 Remove the transformer and shield-can from the bass box.



3. Woofer Removal

3.1 The Grille on the bass module is glued into place. The woofer is not replaceable. Replace the bass box assembly if the woofer is defective.

Test Procedures

Test Equipment required:

1. Audio Signal Generator
2. Oscilloscope
3. Digital Multimeter

Test Set up

Connect the satellites to the output jacks on the bass module.

Connect the control pod to the DIN jack on the bass module.

Connect a signal generator to the audio input cable and connect the cable to the input jack on the bass module.

1. Bass Module Air Leak test

1.1 Apply a 40 mVrms, 40 Hz signal to the input of the bass module.

1.2 Set the volume knob on the control pod to maximum (fully clockwise), and set the bass control to the center detent (flat) position.

1.3 Listen carefully for air leaks along all glued joints, around the heat sink, connectors and at the woofer mounting location.

1.4 Repair any air leaks around the heat sink and connectors. Replace any bass module that has air leaks around the bass box or woofer mounting location.

2. Bass Module Sweep Test

2.1 Apply a 200 mVrms, 100 Hz signal to the input of the bass module.

2.2 Set the volume knob on the control pod to maximum (fully clockwise), and set the bass control to the center detent (flat) position.

2.3 Listen carefully as you sweep the bass module from 100 Hz to 300 Hz, then from 300 Hz to 100 Hz.

2.4 Listen carefully for buzzes, rattles, or other extraneous noises from the woofer, cabinet, plastic trim parts, or heat sink. A slight whooshing sound from the port at approximately 45 Hz is acceptable.

2.5 Repair any noise heard from around the heat sink and connectors. Replace the bass module if it has noises from the woofer or cabinet area.

Test Procedures

3. Bass Module Tone Control Test

3.1 Apply a 90 mVrms, 100 Hz signal to the input of the bass module.

3.2 Set the volume knob on the control pod to maximum (fully clockwise), and set the bass control to the center detent (flat) position.

3.3 Rotate the tone control fully clockwise and counter clockwise.

3.4 Verify that the bass level cleanly increases and decreases in level.

4. Satellite Air Leak Test

4.1 Apply a 270mV, 200 Hz signal to the input of the bass module.

4.2 Set the volume knob on the control pod to maximum (fully clockwise), and set the bass control to the center detent (flat) position.

4.3 Listen carefully for air leaks along edges of the satellite and near the grille where the Twiddler speaker is installed.

4.4 Replace any satellite that is defective.

5. Satellite Sweep Test

5.1 Apply a 270mV, 100 Hz signal to the input of the bass module.

5.2 Set the volume knob on the control pod to maximum (fully clockwise), and set the bass control to the center detent (flat) position.

5.3 Sweep the satellite speakers from 100 Hz to 3 kHz then from 3 kHz to 100 Hz.

5.4 Listen carefully for buzzes, rattles, or other extraneous noises from the Twiddler™ speakers, plastic satellite enclosure, grille, or internal wires.

5.5 Replace any satellite that is found to be defective.

Test Procedures

6. Control Pod Functional Test

6.1 With the system completely set up, turn on the system using the power switch located on the bass module.

6.2 Set the volume knob on the control pod to maximum (fully clockwise), and set the bass control to the center detent (flat) position.

6.3 Touch the center of the control pod . Verify that the LED turns from green to orange and orange to green with each touch.

6.4 Verify that the sound is muted and un-muted when the LED changes color and that there is no audible pop when switching from mute to un-mute.

6.5 Rotate the control pod ring, verify that the volume increases and decreases and that the ring moves smoothly.

6.6 Replace any control pod that is defective.

Theory of Operation

The Companion® 3 Multimedia Speaker System is a 2.1 system designed to be used as a computer sound system.

The electronics contain signal processing circuitry and the amplifiers for the woofer and satellites. A 120 volt AC input, 14 volt DC power supply powers the electronics. The power supply is located on a separate PC board.

The signal processing electronics in the bass module include equalizers, bass summing, TrueSpace™ processing, level compression, to prevent clipping at high volume, and protection circuitry.

The crossover frequency between bass and satellites is 300 Hz. The system is rated at 60 watts to the woofer and 18 watts to each satellite. The bass box is tuned to 45 Hz.

The following is a detailed description of the circuitry on the power supply, amp board, and remote board.

1.0 Power Supply (refer to the schematic diagram 276769)

The power supply is located on the heat sink of the module and is the smaller PCB of the two. The 120 volt AC is received from the AC inlet jack and switch at J1. The AC is fused by the 4 amp F1 fuse. VR1 protects against high voltage surges. The 120 volts is sent out to the 15 VAC, 7 amp toroid transformer mounted to the interior of the bass box on J2. The 15 VAC secondary voltage comes back into the board on J2. The 15 VAC is converted to 15-20 volts DC by bridge rectifier BR1.

Q1, Q2 and Q3 form a pre-regulator to keep the DC output voltage at 14 VDC. The 13 volt zener D1 serves as a reference to Q1. When the input AC goes one diode drop above the zener voltage, Q1 turns on. This turns off Q2, allowing Q3 to turn off, which disconnects the input rectified AC from charging C7, the 3300 uF filter capacitor above 14 volts. This makes the voltage at C7 stay at about 14 volts. C2, C3 and C4 slow down the turn on of Q3 to reduce interference from this circuit to the amplifier.

When the rectified voltage is lower than 14 volts, Q1 turns off, turning on Q2 and then Q3, allowing C7 to charge whenever the rectified voltage from BR1 is above the voltage left on C7. The 14 VDC is sent to the amplifier board over J3.

RT1 is a 22K thermistor at room temperature. It is mounted on the heat sink between BR1 and Q3. It senses the system temperature and sends a signal to the main amp board to help reduce system gain when the heat sink is getting too hot.

2.0 Main Amplifier Board (refer the schematic diagram 276762)

On sheet 1 of 3, location (D8), is the A input. U3, (D7) buffers the inputs to be sent to the remote control through J308. The remote mixes the A with the B input, on the remote, and sends the signal back to the main PCB through J308. The control pod is further described in section 3.

Theory of Operation

2.0 Main Amplifier Board (continued) (refer the schematic diagram 276762)

The signals coming into J308 (C7) are sent to sheet 3 of 3 (L_VOL and R_VOL). Three amplifiers in U201 (D8-4) are the equalizers for the right channel and U125, (A8-4) are the equalizers for the left channel. U951 (C8-3) in conjunction with U950 (C-2), the voltage controlled amplifier, form the bass summer and dynamic bass equalizer.

The three stage equalizers for the equalizer perform the bass cutoff, mid-range cut, and high end boost, in that order. They are 4-pole Salen-Key elliptical filters.

The bass signal is formed from the two inputs summed and low pass filtered by U951. The bass level is detected by U125, D951, D952, Q950, Q951 and Q952 (B-6) forming an active peak detector. C955 and C957 filter the detected peaks to form the control voltage for the VCA in U950. When the bass level is very low, the signal is boosted by U951. U950 is in the negative feedback path for U951, and when its gain is low, U951 gain goes up, boosting the bass. U950 gain goes down when control current generated by Q952 goes down, as controlled by peak detector circuit.

Q953, Q954 and D954 (D-2) form the peak detector on the bass outputs. Peaks near the negative rail are conducted through D954 and Q953 to charge C969. Voltage on C969 is converted to a current by Q954 which controls the VCA in U950. U950 is in the negative feedback loop of U951, so when U950 gain is high, less bass is output. Near clipping detected by the peak detector is converted to high current by Q954, causing high gain in U950, reducing the gain in U951 and less bass. R980 and C969 determine the attack time of the compressor, and R981 and C969 determine the release time.

Also on sheet 3 of 3, U201 (A-3) is the virtual ground generator. The 10 volt line is divided by two R225 and R226, filtered by C970 and C235, and input to U201. The 5 volts generated by U201 is used by all the signal processing circuitry as the virtual ground reference.

The right and left outputs, EQ_R and EQ_L are sent to page 2 of 3 (B3). U102 (B3) forms the true space processing and the satellite signal compressors. TrueSpace™ processing consists of U102B and U102D which act a low pass filters with a -3 dB point of 3 kHz. This signal is subtracted from the opposite channel signal by U102A and U102C.

R204 and R105 determine how much TrueSpace signal is subtracted. The 127K compared to the 10K value of the main signal inputs gives a TrueSpace signal of -18 dB relative to the main signal. To keep the levels the same in mono conditions, the same amount of low pass filtered signal is added back to the main channel of itself, through R106 and R206.

The satellite compressor consist of D401, D402, and Q401 (D7) which detect the right and left channel level, charging C401 when the R+, R-, L+ and L- signals get near the negative rail. The compressor attack time is determined by R403, and the release time is determined by R404. When C401 charges negatively, Q402 and Q403 convert this to current which increases the gain of U401A and U401B. U401 is in the negative feedback path of U102A and U102C, and higher gain reduces the gain through the satellite channels. Therefore, high signal levels near clipping reduces the gain of the satellite channels, compressing the signals.

The compressed signals are sent to the main amplifier on sheet 1 of 3 over signals Sat_Drv_L and Sat_Drv_R. The bass signal from the bass compressor on sheet 3 of 3, BASS_DRV, is sent to two stages of bass equalization at U3B and U3D (D7). These form the 40 - 50 Hz boost, and the 100 Hz cut for the bass box equalization.

Theory of Operation

2.0 Main Amplifier Board (continued) (refer the schematic diagram 276762)

The two satellite signals, and the bass signal are sent to the power Amp IC, U301 (C3). One channel of the power Amp IC is used for each satellite, and the bass signal uses two channels of the power chip to drive both of the woofer voice coils.

The Amp IC can provide up to 40 watts into 2 ohms per channel. The woofer coils are 2 ohms each, and 60 watts total is specified for the woofer drive. Each satellite can receive 18 watts each into their 4 ohm impedance.

The mute signal from the remote unit comes in through J308, is slowed down by C314 to prevent pops.

The 10 volts for the signal processing circuitry is generated by D301, a 10 volt zener, and Q303 in an emitter follower configuration. Q303 is specified up to 500 ma, and the entire remote and signal processor consumes about 100 ma.

For thermal protection, Q304, Q305, and Q307 (A5) process the voltage generated by the thermistor on the power supply and R337 and generate a current that goes higher as the temperature rises. This current is summed into the three compressors, reducing the gain through the system at high temperatures. This prevents the heat sink from getting too hot. R337 determines the voltage division ratio and therefore the heat sink maximum temperature.

Q308 and Q309 (D5) form a voltage detector that determines when power has reached sufficient voltage for proper power amplifier operation. If the DC voltage falls below 10 volts, the power amplifier will be muted. This prevents power up and down pops.

3.0 Control Pod Remote (refer to schematic diagram 272092)

The remote receives the A input signal from the bass module over J4. This is summed with the B input on the remote control by U2. U2 drives the volume control pot R31. The adjusted volume is sent to U4 to drive the headphone outputs J5 and connector J4 back to the bass module. U1 buffers the 5 volts reference to the sleeve of J5. J5 is a switched jack, and the switch mutes the main speakers when a headphone plug is inserted. This grounds the mute signal, which is active low.

U3 is a touch sensor switch. When the operator touches the touch sensor pad on the remote, which is connected electrically to WT1 and WT2, the QT113 chip will sense this and toggle the standby line. This changes the LED (DS1) color from yellow to green. The green led is always on, and the red led glows during standby, as driven by Q1, to mix with the green to show yellow color. U3 output also drives the standby line to the bass module power amplifier. Standby is active high on the remote, and inverted in the bass module to the active low signal required by the power amplifier.

The remote amplifiers are powered by the 10 volt supply coming in at J4 from the bass module. The virtual ground from the bass module comes in as the VCCD2 signal reference from the signal processing. ZD1 is a 4.7 volt zener which generates the local power supply voltage from the 10 volt input. R41 is the current limiting resistor for ZR1. This 4.7 volts powers U3.

At each I/O connector, resistors, capacitors, diodes, and spark gaps are present on each signal to protect against RF emissions, susceptibility, and ESD.

SERVICE MANUAL REVISION HISTORY

Date	Revision Level	Description of Change	Change Driven By	Pages Affected
9/06	00	Document released at revision 00	Service Manual Release	All
4/07	01	Added pad printed logo part numbers for Bass module and Satellites	Improvement of logo	5, 7
	01	New part number for power supply board – 307872-011 – 120V 307872-022 – 100V 307872-033 – 240V	Improved power supply.	6
8/7	02	Part number changes Mod Assembly 307876-011- 120V 307876-022- 100V 307876-033- 240V Control Pod 307874-002	Improved power supply and Control pod.	5, 7
3//08	03	Added fuse part number 298780-3150	Two versions of the Power PCB, need two versions of the fuse.	18
3//08	04	Deleted part number for BOTTOM EPS FILLER.	The top filler now includes both top and bottom filler.	7
6/09	05	Deleted part number for BOTTOM EPS FILLER.	The top filler now includes both top and bottom filler.	6
1/10	05	Changed part number 178321-08 to 178321-04	ECN 46966	8

SPECIFICATIONS AND FEATURES SUBJECT TO CHANGE WITHOUT NOTICE

BOSE®
Better sound through research®

Bose Corporation
The Mountain
Framingham Massachusetts USA 01701

P/N 297700-SM Rev. 05 09/2007 (H):
<http://serviceops.bose.com>

Troubleshooting Tips

Companion® 3 Series II Multimedia Speaker System

Refer to the Companion® 3 Multimedia Speaker System service manuals, part number 297700 for schematics, PCB layouts and parts lists.

Preventative Repair Measures

Note: Perform the following on all units returned for repair.

Product	Check	Action
Companion 3 series II	Units built before 10/23/2007 (DOM 7289).	Units built before 10/23/2007 will have the Aishi capacitor C7 installed on the power supply PCB. Replace C7 with a United Chemi-Con (UCC) capacitor. Refer to the service manual for the part number. The DOM cut-in date only applies to U.S. variants. Refer to Service Bulletin: <u>271885-B4</u> for further information.

Troubleshooting Tips

Product	Symptom	Check	Action
Companion 3 series II	Intermittent power	Either J308 or the control pod itself can be defective	Use a test control pod to identify if the problem is with the customer's control pod or the connector J308. If the test control pod works, the problem can be identified as the customer having a defective control pod. If the control pod does not fix the problem, J308 is the failed component. J308 is not repairable. The module assembly would have to be replaced. Refer to the Service Manual for the module assembly part number.
Companion 3 series II	Intermittent power	Check J1	Sometimes J1 is not seated properly and may become intermittent. If J1 is intermittent, the cable may need to be replaced or reseated.
Companion 3 series II	No Audio	Check U301	Check pins 6 and 20 for 15Vdc. If the 15Vdc is not present, check all other power supply voltages. If the power supply voltages are present, inject a 1KHz signal into J302. Check pins 14 (right in) and 15 (left in) and then pins 17 (right out) and 21 (left out). If audio is coming in and nothing is going out, replace U301

Troubleshooting Tips, continued

Product	Symptom	Check	Action
Companion 3 series II	No Audio	Make sure the unit isn't stuck in standby	At IC U301, place your positive probe on pin 22 and the negative probe on ground. Toggle the control pod between mute and standby by touching the top of the control pod. When the LED is green, the voltmeter should read 11Vdc. When the LED is yellow, the voltmeter should read 0Vdc.
Companion 3 series II	No Bass	Check U3	Insert a 200 mVrms, 200Hz signal into J302. Check U3, pin 10 for a signal going into the IC and check pin 14 for the signal coming out. If there is a signal going in but nothing coming out, replace U3 using the part number in the Service Manual.
Companion 3 series II	Intermittent Audio from Left or Right Speakers	Check J307	With the speakers connected and an audio source playing, wiggle the speaker connections and listen to see if the audio cuts out or becomes intermittent. Before determining the connectors as a failure, be sure to inspect the speaker cable for broken or intermittent connections. J302 is non-repairable; Replace the module assembly.
Companion 3 series II	No Audio or Dead Unit	Check the Control Pod	Check the pins inside the din connector at the end of the control pod cable to see if any pins are misshaped, bent or broken. Also, inspect J308 to make sure none of the pins has broken off. If the control pod connector is defective, replace it.

SERVICE BULLETIN

Bulletin Part Number: 271885-B2

Product: Companion[®]3 Multimedia Speaker System

Subject: No Audio Output

Disposition: All units in for repair with a no audio complaint.

Symptom: No audio output from the system and the control pod LED is dimly lit.

Reason: Q303 on the main PCB is defective or shorted completely.

Solution: Replace Q303 with part number 148770. Add a 1N4148 diode part number 121501 across the base and emitter junction. Polarity is very important. Connect the cathode of the diode to the base and the anode to the emitter. Refer to the figures below for the location of Q303 and orientation of the diode. Also replace R336, as identified in the table below. Refer to the Companion 3 Speaker System service manual part number 271885-SM.

Component	From	Part Number	To	Part Number
R336	2.2 Ohm	133625-2R25	10 Ohm	133625-10R0

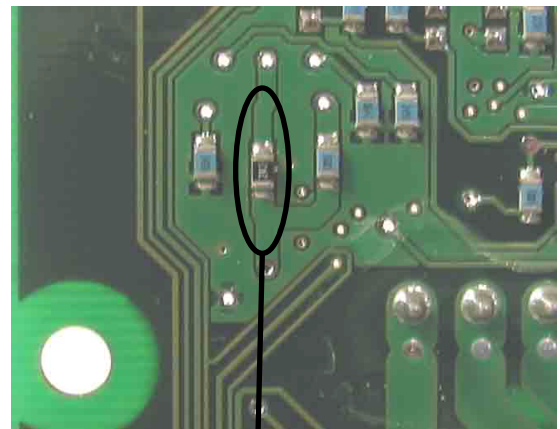
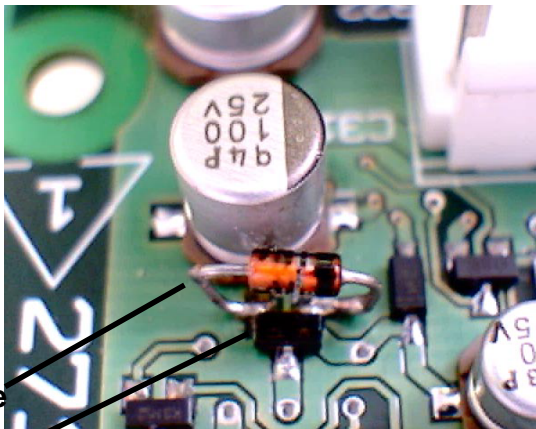

1N4148 Diode

Q303

R336

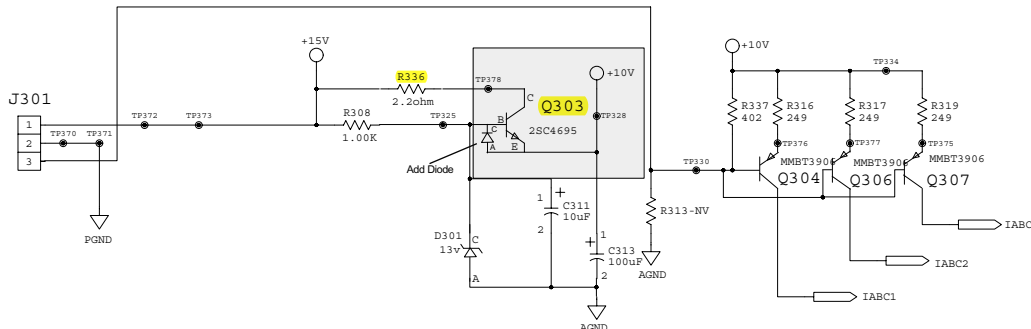

Date: 09/04

FINS: 1569



SAFETY BULLETIN

Bulletin Part Number: 271885-SB3

Product: Companion[®] 3 Multimedia Speaker System

Subject: Possible failure of C316, C317, C318 and C319 on the main PCB assembly.

Disposition: All Companion[®] 3 Multimedia Speaker System built before 11/11/05 (DOM below 5315).

Symptom: The four capacitors should be replaced regardless of symptom.

Reason: The capacitors C316, C317, C318 and C319 may crack due to flexing of the board. This can cause the capacitors to have a low resistance and create a DC offset voltage on the output of the amplifier.

Solution: Replace C316, C317, C318 and C319 with a new type (Kemet open-mode ceramic) and value (0.1uF) part number 286499-104. This change will prevent possible DC offset voltages due to a cracked capacitor. Refer to the Companion[®] 3 service manual part number 271885-SM for disassembly/assembly and test procedures. Verify proper operation before returning the system to the customer.

NOTE: There are two versions of the board, the original board is labeled with 271838 and present board is labeled with 280066. Both versions need the four capacitors replaced with the new part number. The two different versions are shown on Page 2 of this document.

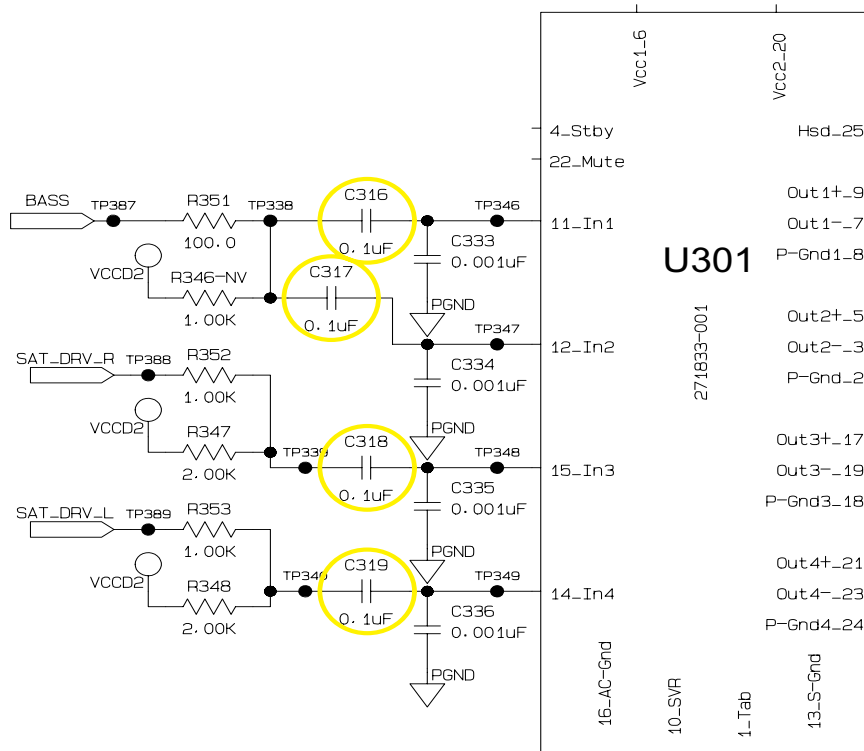

Location of C316, C317, C318 and C319
on Sheet 1 of SD280066 and SD271838

FINS: 2476, 2499 and 2619

FRACAS: 494

Date Issued: 10/05



SAFETY BULLETIN

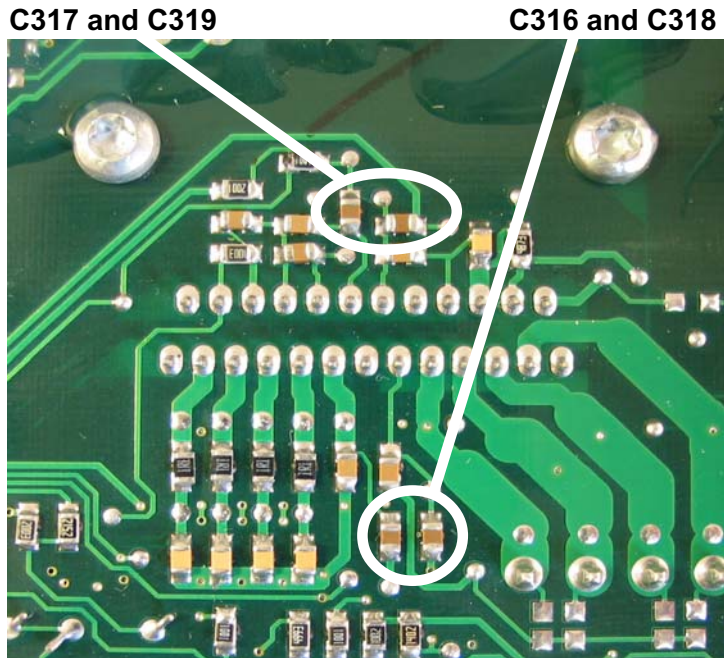

Location of C316, C317, C318 and C319 on the bottom side of 280066-001 PCB

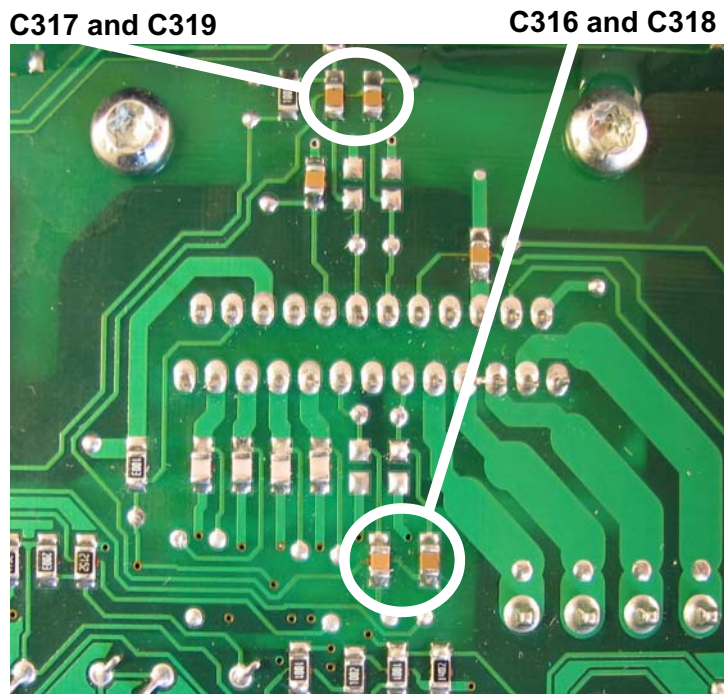

Location of C316, C317, C318 and C319 on the bottom side of 271838-001 PCB

FINS: 2476, 2499 and 2619

FRACAS: 494

Date Issued: 10/05

SERVICE BULLETIN

Bulletin Part Number: 271885-B4

Product: Companion[®] 3 Multimedia Speaker System

Subject: Poor reliability on vendor part

Disposition: On all units that come in for repair, replace C7 with a Chemi-Con capacitor

Symptom: No Audio, Dead Unit or No Symptom

Reason: The capacitor made by Aishi is made using a low quality foil and poor quality etching which is critical to the performance of an aluminum electrolytic capacitor. The capacitor made by United Chemi-Con (UCC) is more dense and has more uniform layering which makes the UCC capacitor more reliable.

Solution: All units that come in for repair, replace C7 using the part number listed in the table below. For assembly/disassembly procedures, please refer to Service Manual 271885-SM (Companion[®] 3 Multimedia Speaker System) or 297700-SM (Companion[®] 3 Series II Multimedia Speaker System).

Variant	Description	Part Number
US	33000 μ F, EL, AL, 25V, 4T	260693-3331E
Euro/Japan	39000 μ F, EL, AL, 25V	260693-3931E

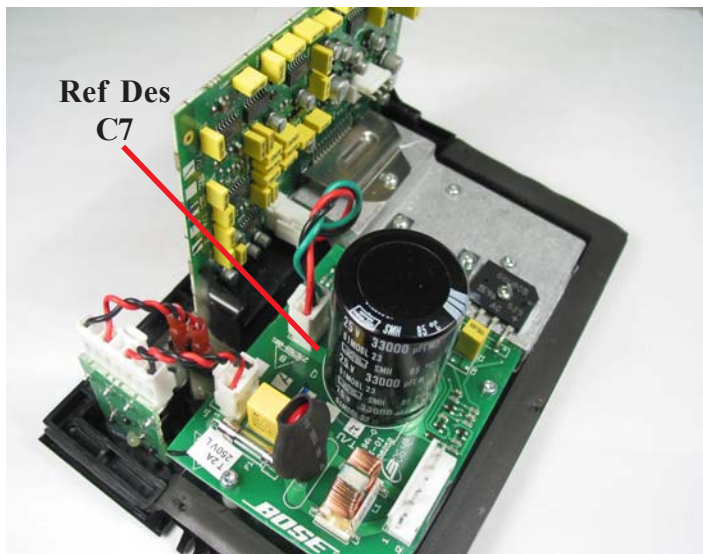

Ref Des
C7



FINS: 2784
Date: 11/07