

# Manual de Serviço

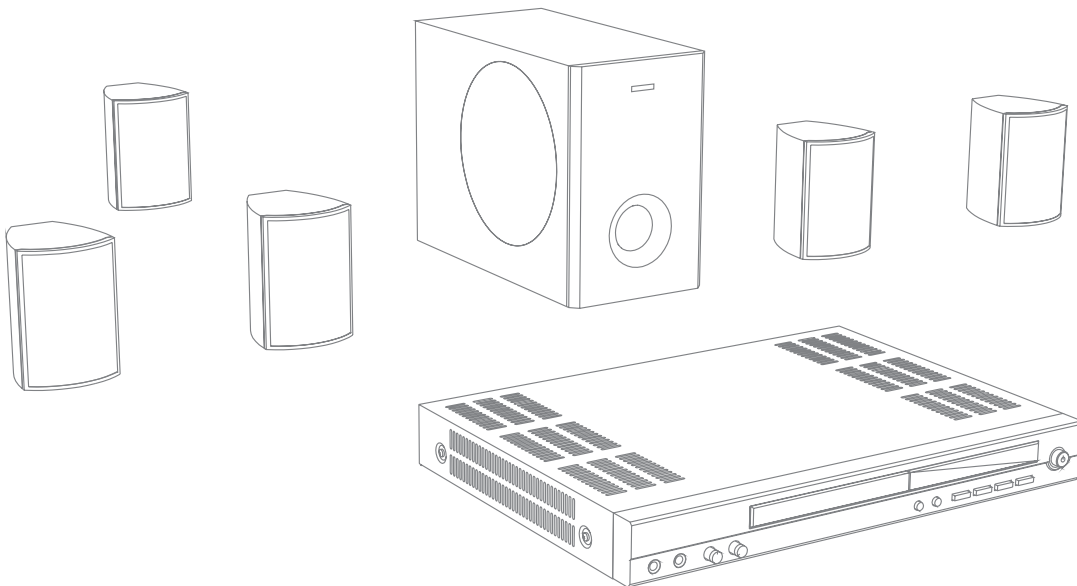

**T  
H  
E  
A  
T  
E  
R  
  
B  
S  
I  
  
1  
0  
0  
0  
0**

**0800 415300**

[assistenciatecnica@britania.com.br](mailto:assistenciatecnica@britania.com.br)

**Política da Qualidade Britânia**

*"Oferecer produtos que contribuam para a satisfação de nossos clientes, buscando a melhoria contínua de nossos processos"*

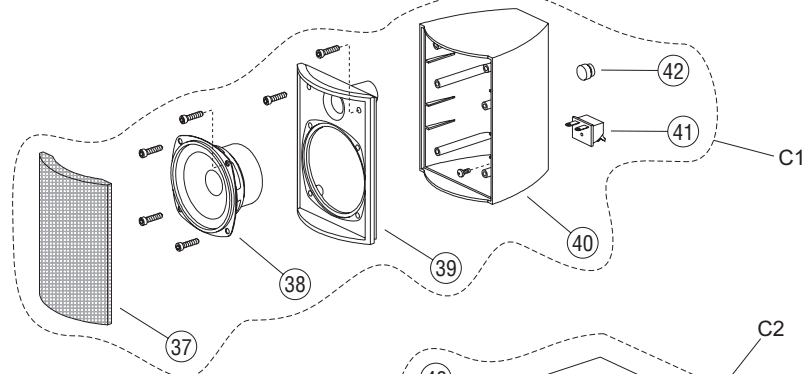
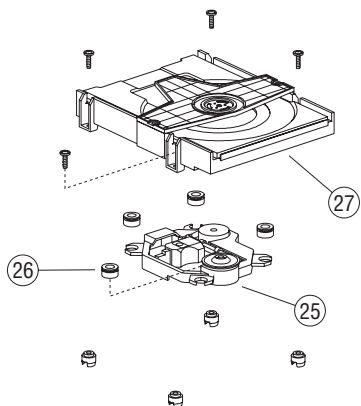
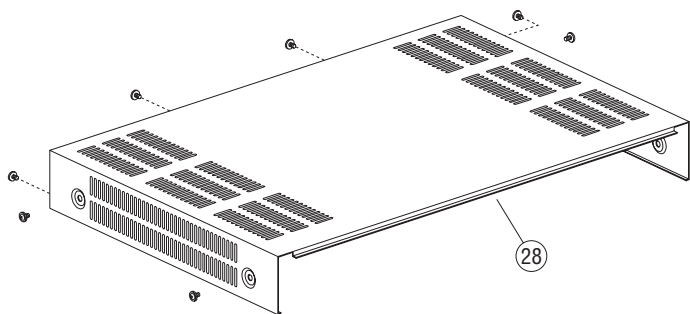

VISTA EXPLODIDA

CÓDIGO DO PRODUTO  
067003100

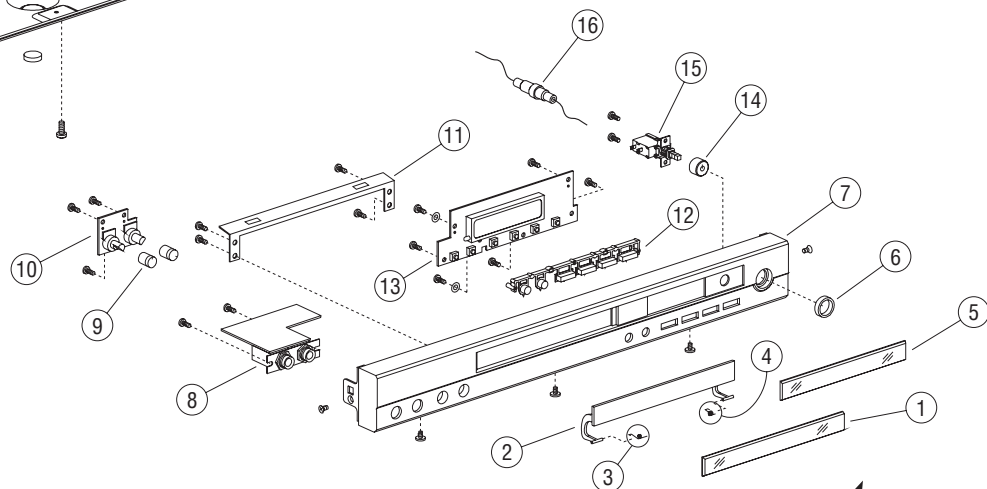
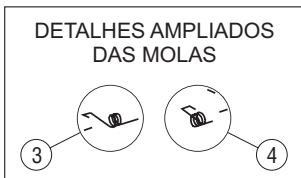
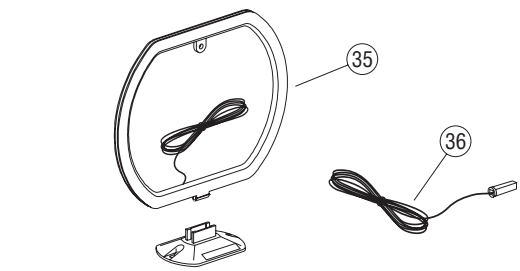
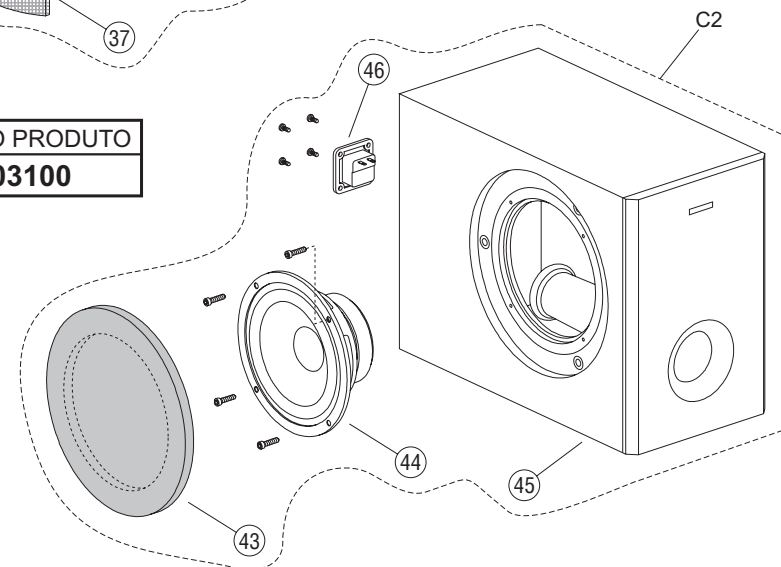
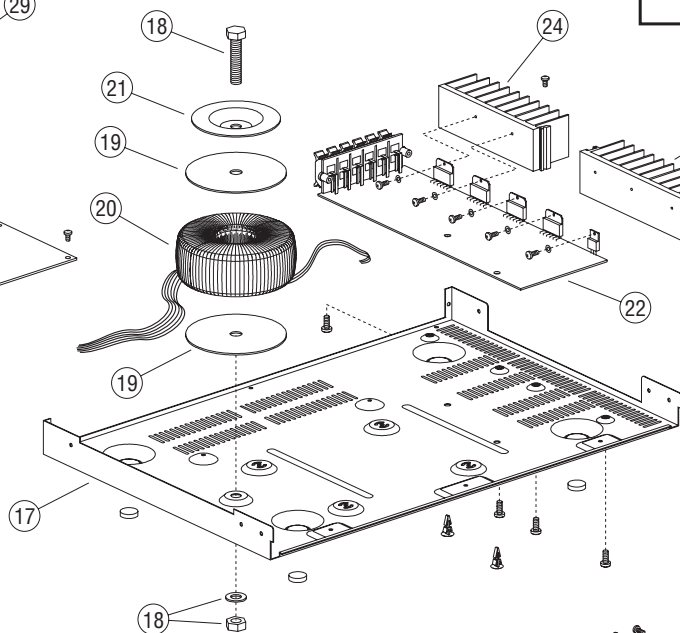
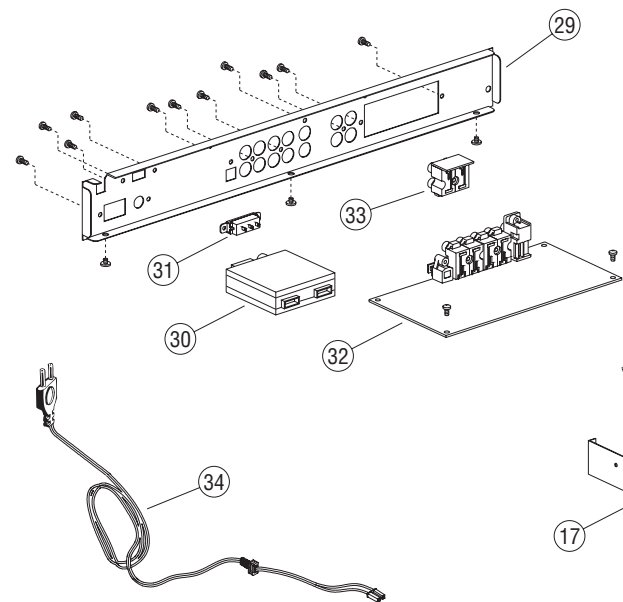

# VISTA EXPLODIDA AMPLIADA DO PAINEL

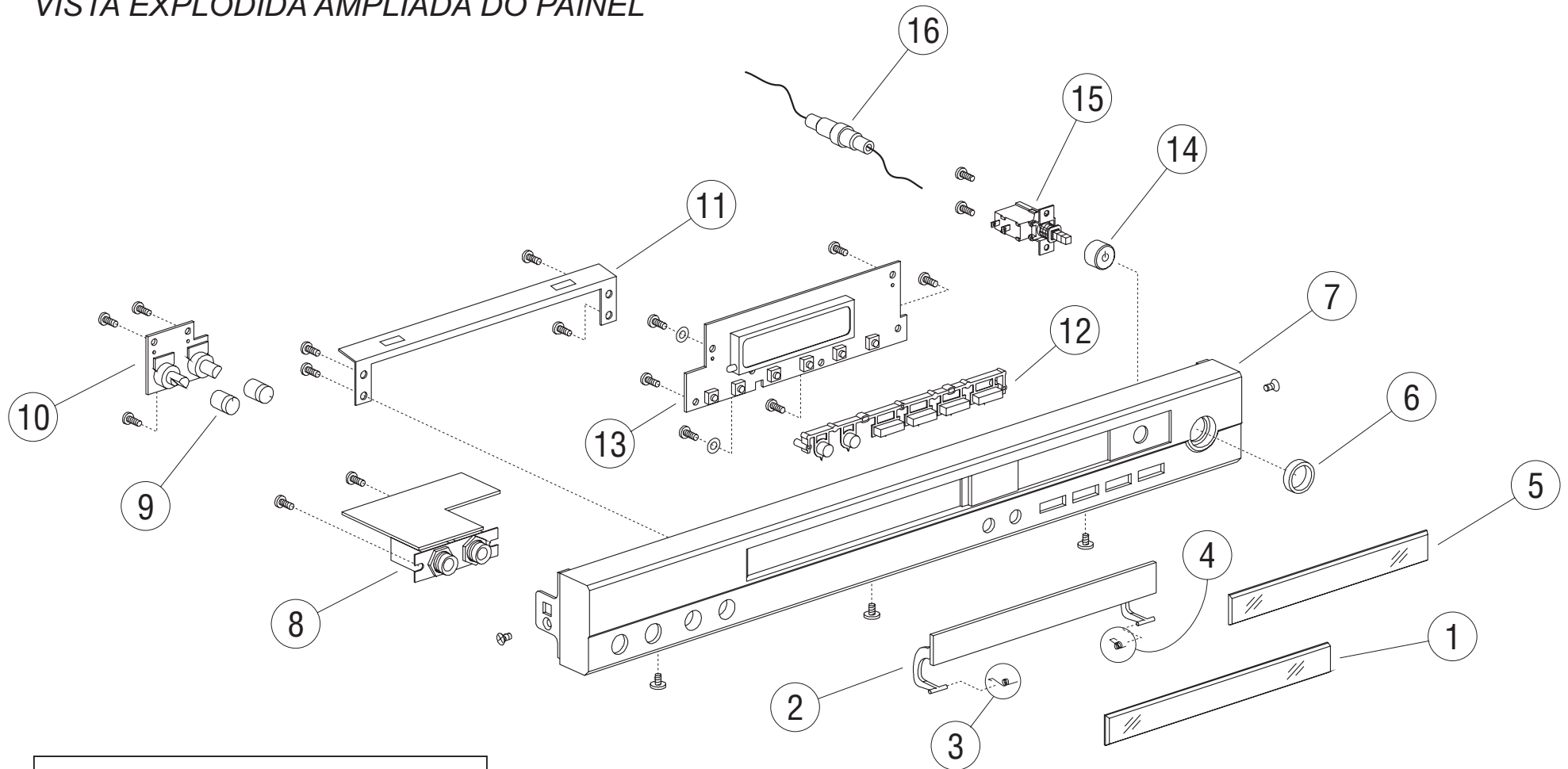

## DETALHES AMPLIADOS DAS MOLAS

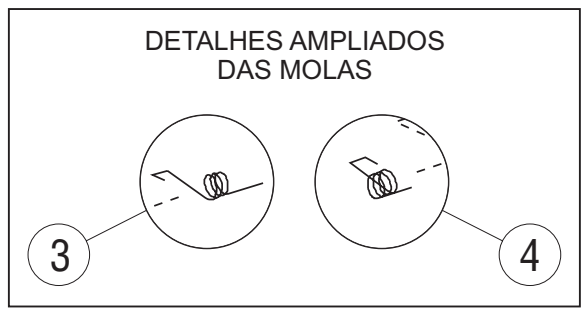

ITENS DA VISTA EXPLODIDA

Nº	DESCRIÇÃO	CÓDIGO
1	DECORAÇÃO PROTEÇÃO GAVETA BSI-10000	704157
2	PROTEÇÃO GAVETA BSI-10000	704156
3	MOLA PROTEÇÃO GAVETA ESQ BSI-10000	704159
4	MOLA PROTEÇÃO GAVETA DIR BSI-10000	704158
5	VISOR DISPLAY BSI-10000	704152
6	DECORAÇÃO AZUL CHAVE POWER BSI-10000	704153
7	GABINETE FRONTAL BSI-10000	703554
8	PCI KARAOKÊ BSI-10000/20000	703551
9	KNOB MIC/ECHO BSI-10000	704160
10	PCI CONTROLE MICROFONE BSI-10000	704163
11	REFORÇO GABINETE FRONTAL BSI-10000	704162
12	BOTÕES COMANDO BSI-10000	704155
13	PCI DISPLAY BSI-10000	703550
14	KNOB POWER BSI-10000	704154
15	CHAVE MASTER	702070
16	PORTA-FUSIVEL BSI-10000/20000	704174
17	GABINETE INFERIOR BSI-10000	704176
18	CONJ. PF/ARRUELA/PORCA BSI-10000/20000	704182
19	DISCO ISOLAÇÃO TRANSFORM. BSI-10000/20000	704181
20	TRANSFORMADOR TOROIDAL BSI-10000	703560
21	DISCO FIXAÇÃO TRANSFORMADOR BSI-10000	704180
22	PCI POTÊNCIA BSI-10000	703552
23	DISSIPADOR POTÊNCIA DIR BSI-10000	704169
24	DISSIPADOR POTÊNCIA ESQ BSI-10000	704170
25	UNIDADE ÓTICA KHM-310AAA (R)	703493
26	AMORTECEDOR DVD RYD-310 PR (R)	703565
27	MECANISMO DVD SEM U. ÓTICA RYD-310AAA (R)	703564
28	GABINETE SUPERIOR BSI-10000	704150
29	GABINETE TRASEIRO BSI-10000	704172
30	MÓDULO RÁDIO AM/FM COMP BSI-10000/20000 (R)	703553
31	CHAVE VOLTAGEM HT5000 BSI-10000/20000	703483
32	PCI PRINCIPAL BSI-10000	703558
33	PCI ENTRADA ÁUDIO BSI-10000/20000	704164
34	CORDÃO ELÉTRICO DVD	701613
35	ANTENA AM BSI-10000/20000	704197
36	ANTENA FM BSI-10000/20000	704196
37	TELA CAIXA SATÉLITE BSI-10000	704186
38	ALTO-FALANTE SATÉLITE 8R 8W BSI-10000	703559
39	GABINETE FRONTAL CAIXA SATÉLITE BSI-10000	704187
40	GABINETE TRASEIRO CAIXA SATÉLITE BSI-10000	704188
41	CONECTOR CX SATÉLITE VERM/PR BSI-10000/20000	704185
42	ROSCA FIXAÇÃO CAIXA SATÉLITE BSI-10000	704189
43	TELA CAIXA WOOFER BSI-10000	704194
44	ALTO-FALANTE WOOFER 8R BSI-10000	704191
45	GABINETE CAIXA WOOFER BSI-10000	704192

DEMAIS COMPONENTES FORNECIDOS

Nº	DESCRIÇÃO	CÓDIGO
46	CONECTOR CX WOOFER VERM/PR BSI-10000/20000	704193
C1	CAIXA ACÚSTICA SATÉLITE BSI-10000	704183
C2	CAIXA ACÚSTICA WOOFER BSI-10000	704190

DESCRIÇÃO	CÓDIGO
BARRA CONTATOS SAÍDA CX ACÚST BSI-10000/20000	704168
CABO ÁUDIO E VÍDEO	702065
CABO FLAT 24 VIAS x 22CM x 1,2CM (R)	704171
CABO POL 25AWG PR/VERM 4,8m BSI-10000/20000	704195
CHICOTE 5 VIAS x 13CM BSI-10000/20000	704177
CHICOTE 5 VIAS x 33CM BSI-10000/20000	704178
CHICOTE 6 VIAS x 35CM BSI-10000/20000	703195
CIRC. INT. 24C16AN	704166
CIRC. INT. 4558	701907
CIRC. INT. A5954	701640
CIRC. INT. CHMC D4558	701907
CIRC. INT. CW7812	702721
CIRC. INT. LC72131	702714
CIRC. INT. MEMÓRIA GRAV 29LLV800BE-70PFTN (BSI-10000)	704165
CIRC. INT. MEMÓRIA ISSI IS42516100C1-7T	704161
CIRC. INT. MT1389XE	704025
CIRC. INT. MV348	704173
CIRC. INT. PCM 1606	703366
CIRC. INT. PT2322	702718
CIRC. INT. PT2323	702715
CIRC. INT. PT2399	704151
CIRC. INT. PT6312BL	701904
CIRC. INT. TDA7265	702720
CIRC. INT. TDA7269A	702719
CONJ. CALÇOS DE PROTEÇÃO BSI-10000	704201
CONTROLE REMOTO BSI-10000	703557
EMBALAGEM BSI-10000	703561
MANUAL DO USUÁRIO BSI-10000	703562
POTENCIÔMETRO 1OKR M-PLUS/10000/20000	703235
SENSOR INFRAVERMELHO	701659
TRANSISTOR 9014C	700107
TRANSISTOR C1815	702986
TRANSISTOR PJ117A	703238
TRANSISTOR S8050	700105
TRANSISTOR S8050	700105
TRANSISTOR S8550	700106
TRANSISTOR S8550	700106
TRANSISTOR TIP41C	704167
TRANSISTOR TL431C	701632

NOTA:  
Dos itens da página 2, somente aqueles que possuem códigos relacionados nas tabelas serão fornecidos.

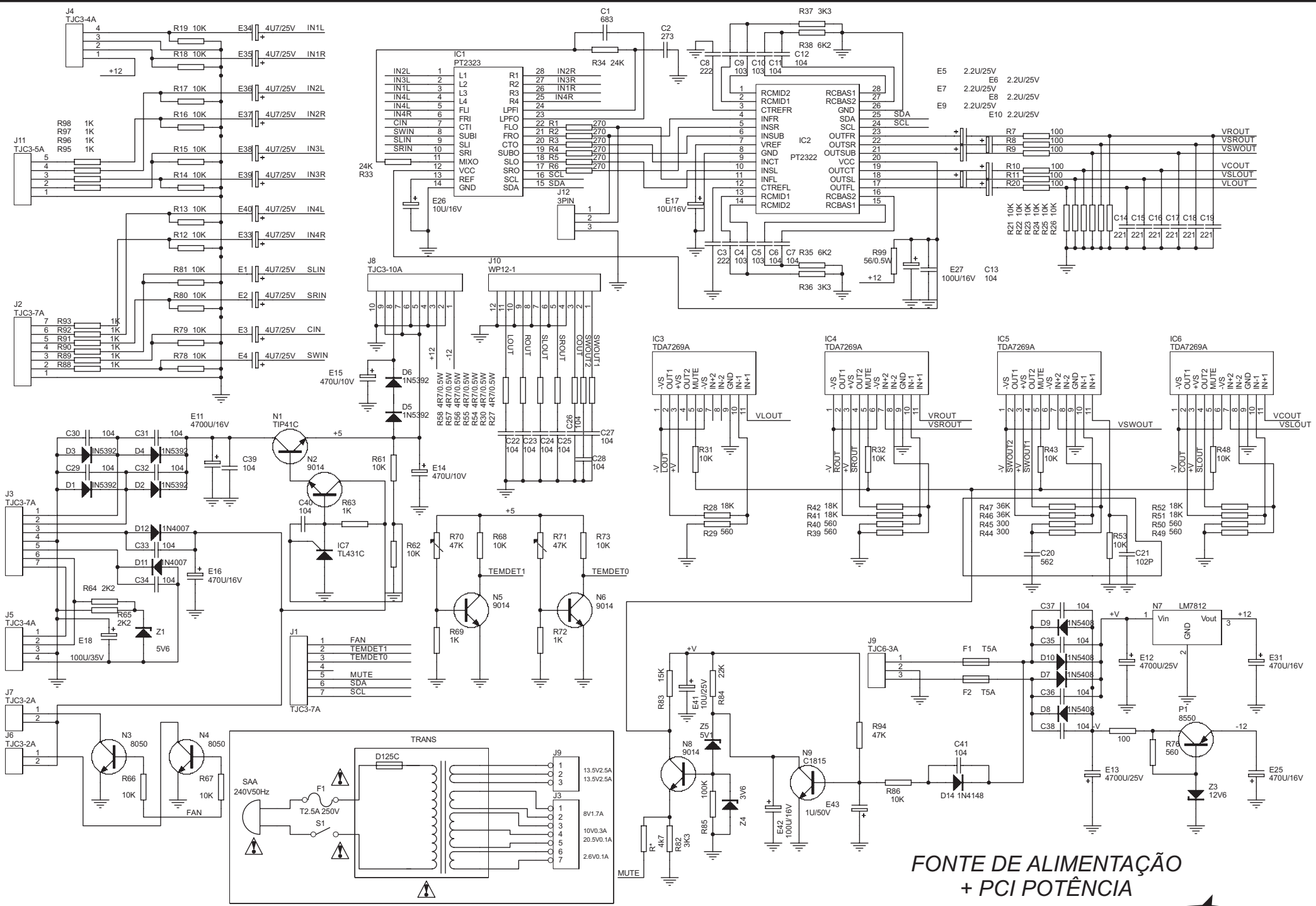

**FONTE DE ALIMENTAÇÃO  
+ PCI POTÊNCIA**

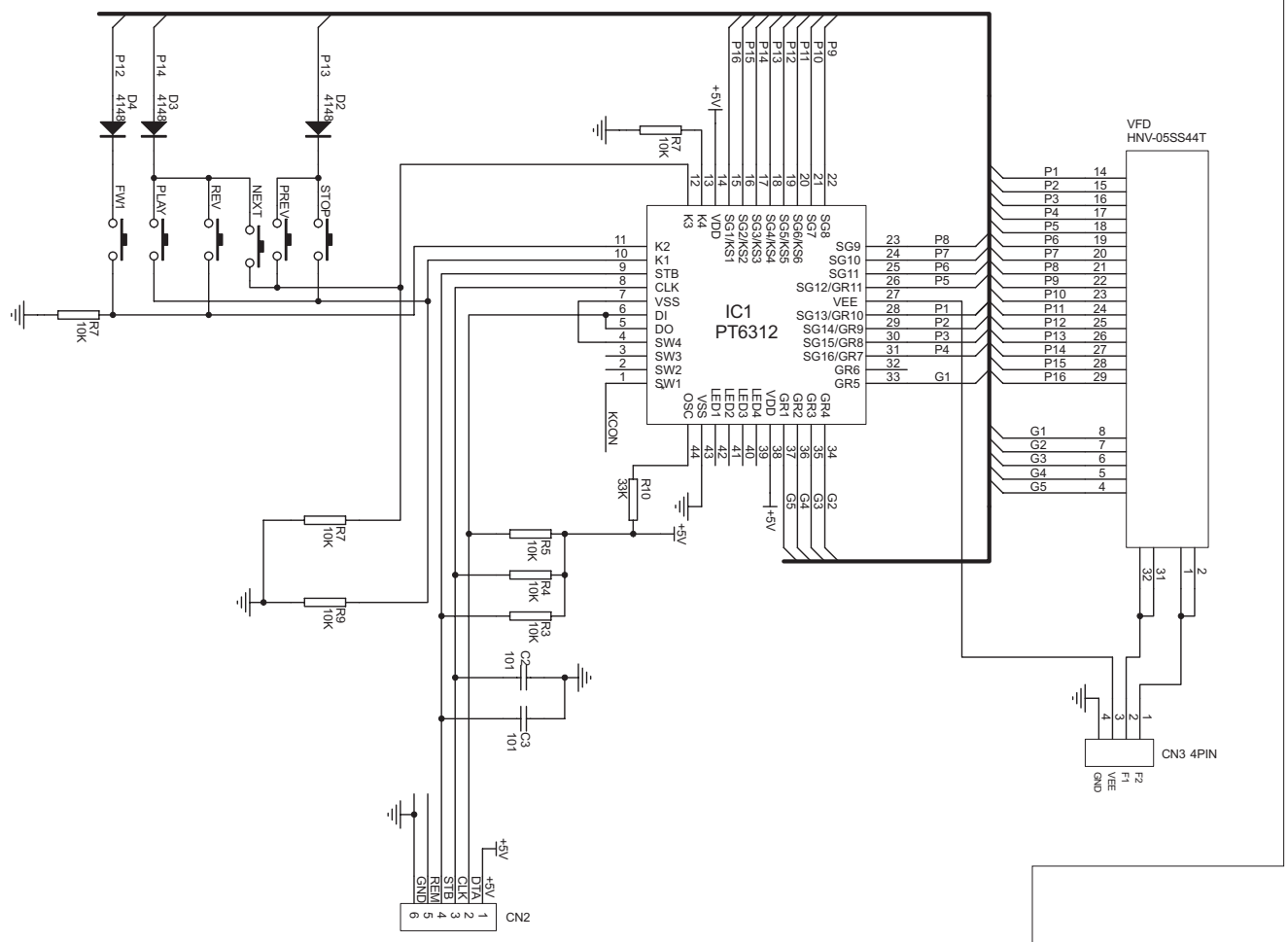

PCI DISPLAY E TECLADO

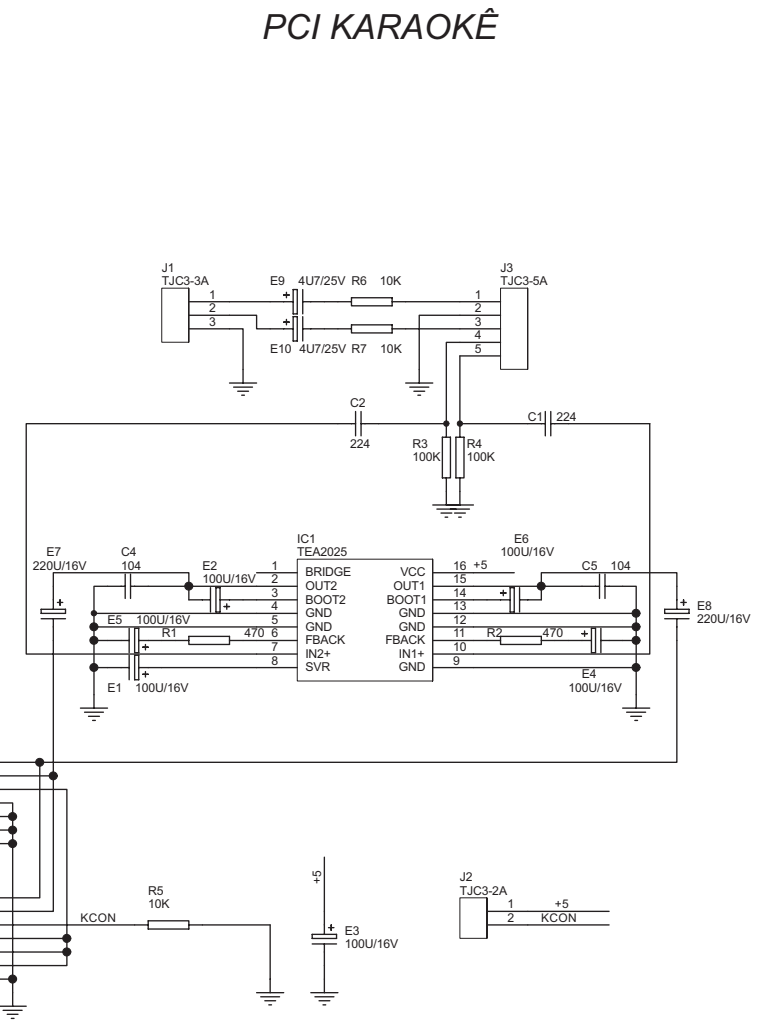

PCI KARAOKÊ

# VTREK1379AM6-5.1

## MISSIONRIGHT MT1379E (LQFP218) AAMP DVD Board for sony khm310

- 1 INDEX & POWER, RESET
- 2 RF / SERVO - MT1336E
- 3 MPEG - MT1379E
- 4 MEMORY , SDRAM , VIDEO FILTER AND OUTPUT

NAME	TYPE	DEVICE
VCC	Digital 5V	SUPPLY
RVCC	Servo 5V	MT1336E
AVCC	RF 5V	PICKUP HEADER
V33	Digital 3.3V	SDRAM, Flash, VideoDAC
DV33	Digital 3.3V	MT1379E
AV33	Servo 3.3V	MT1379E
V25	Digital 2.5V	MT1379E
+5VA	Audio 5V	Audio DAC
+5VV	Video 5V	Video filter

NAME	TYPE
GND	Digital Ground
SGND	Servo Analog Ground
AGND	Audio Ground
VGND	Video Ground

### ESTÁGIO ALIMENTAÇÃO PCI PRINCIPAL

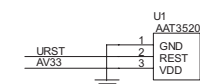
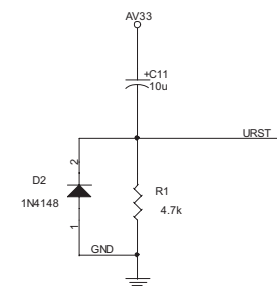
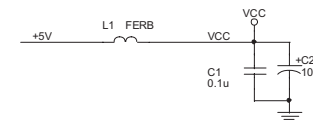
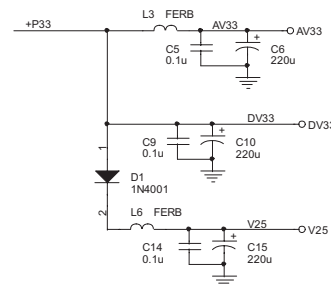
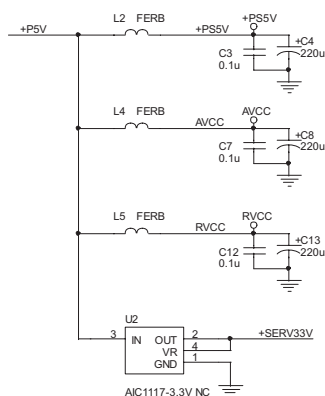
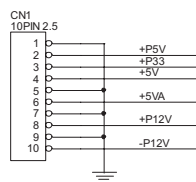

- +SERV33V >> +SERV33V [ 2 ]
- +5VA >> +5VA [ 2,3,4,5 ]
- VCC >> VCC [ 2,3,4,5 ]
- AV33 >> AV33 [ 2 ]
- DV33 >> DV33 [ 2,3,1 ]
- V25 >> V25 [ 2 ]
- +P55V >> +P55V [ 2 ]
- AVCC >> AVCC [ 2 ]
- RVCC >> RVCC [ 2 ]
- P12V >> -P12V [ 2 ]
- +P12V >> +P12V [ 2 ]
- URST >> URST [ 2 ]
- GND >> GND [ 2,3,4,5 ]

# MT1336/76+MT1379 with sony Slim khm310 PUH.

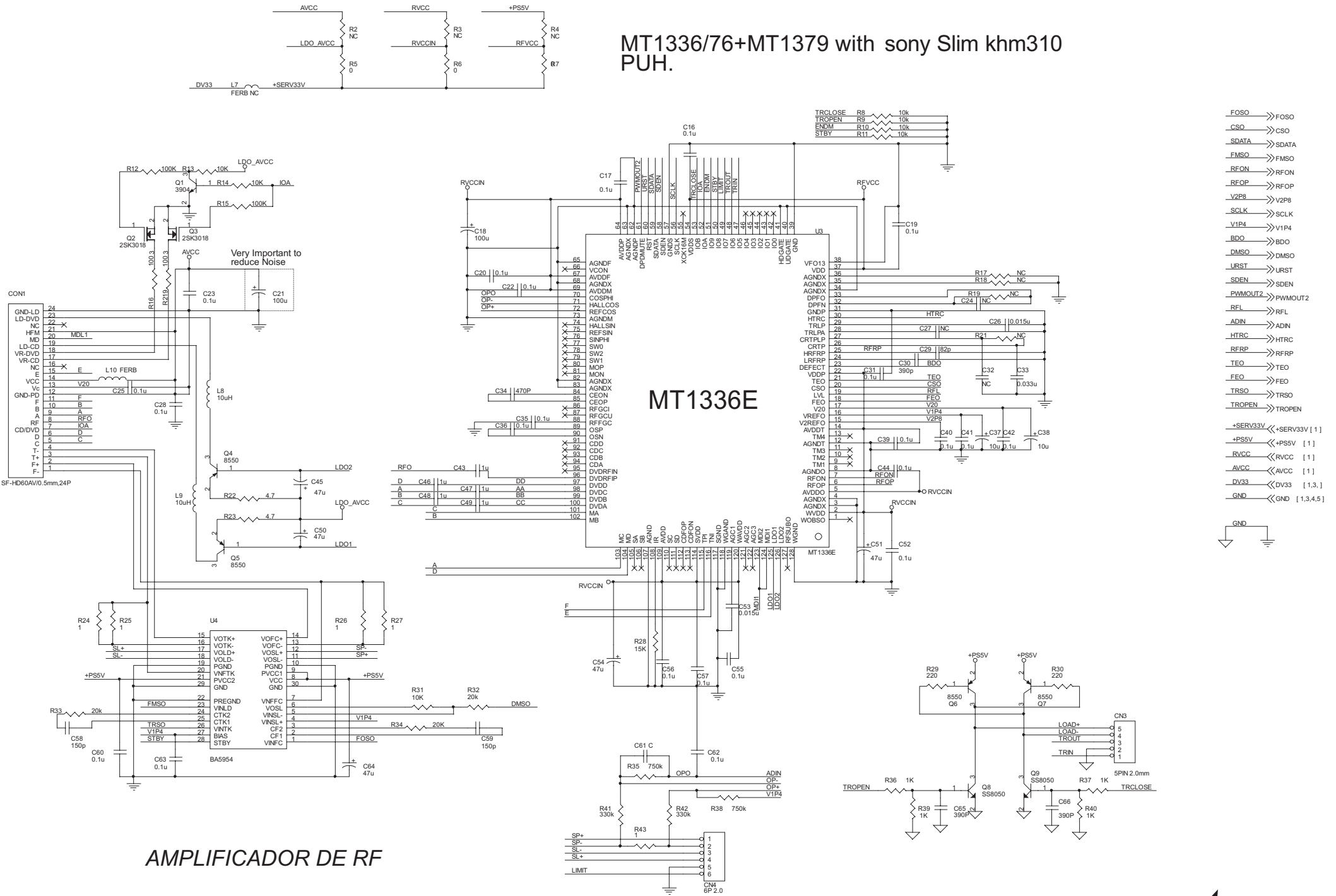

Safield & Freitas / Curitiba

out/2005



- [2] FOSO >> FOSO
- [2] CSO >> CSO
- [2] SDATA >> SDATA
- [2] FMSO >> FMSO
- [2] RFON >> RFON
- [2] RFOP >> RFOP
- [2] V2P8 >> V2P8
- [2] SCLK >> SCLK
- [2] V1P4 >> V1P4
- [2] BDO >> BDO
- [2] DMSO >> DMSO
- [2] URST >> URST
- [2] SDEN >> SDEN
- [2] PWMOUT2 >> PWMOUT2
- [2] RFL >> RFL
- [2] ADIN >> ADIN
- [2] HTRC >> HTRC
- [2] RFRP >> RFRP
- [2] TEO >> TEO
- [2] FEO >> FEO
- [2] TRSO >> TRSO
- [2] TROPEN >> TROPEN

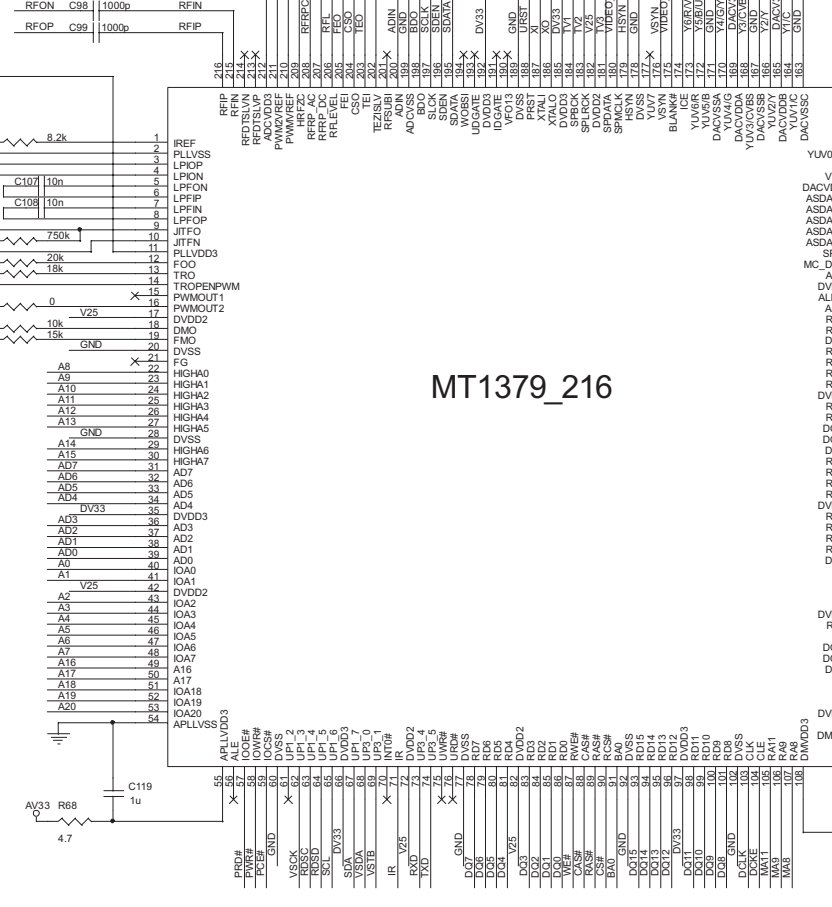
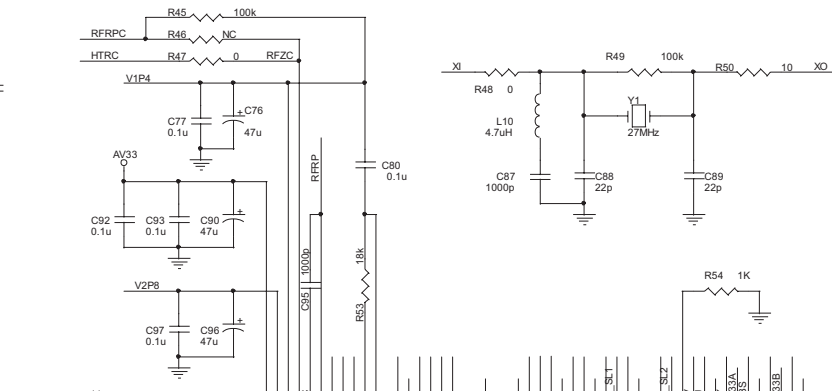
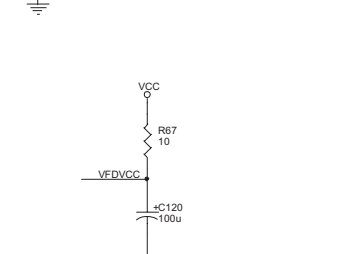
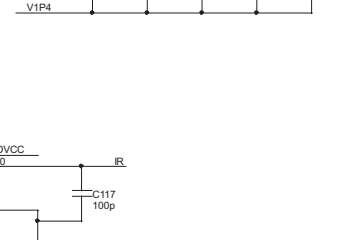
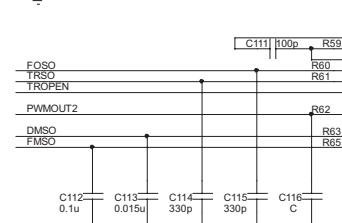
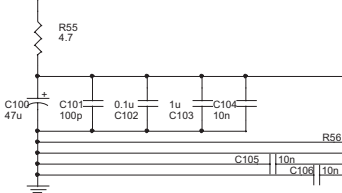
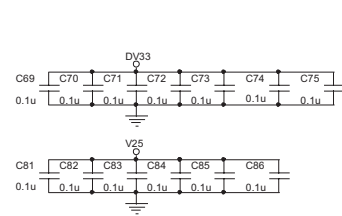

MT1379\_216

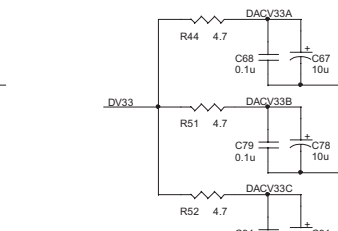
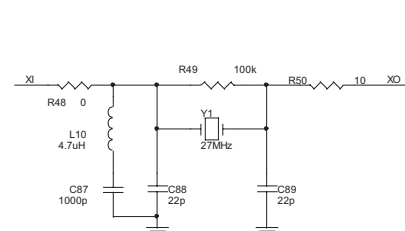

- VCC <<< VCC [1,2,4,5]
- AV33 <<< AV33 [1]
- V25 <<< V25 [1]
- DV33 <<< DV33 [1,3,]
- GND <<< GND [1,3,4,5]
- URST <<< URST [1]
- HSYN <<< HSYN [5]
- VSYN <<< VSYN [5]
- Y1/C <<< Y1/C [4]
- Y3/CVBS <<< Y2/Y [4]
- Y4/GY <<< Y3/CVBS [4]
- Y5/BU <<< Y4/GY [4]
- Y6/RV <<< Y5/BU [4]
- VIDEO\_SL1 <<< VIDEO\_SL1 [5]
- VIDEO\_SL2 <<< VIDEO\_SL2 [5]
- DTS\_DO <<< DTS\_DO [1]
- DTS\_CE <<< DTS\_CE [1]
- DTS\_DI <<< DTS\_DI [1]
- DTS\_CL <<< DTS\_CL [1]
- TUNED <<< TUNED [1]
- STEREO <<< STEREO [1]
- RDSC <<< RDSC [3]
- RDSO <<< RDSO [3]
- RST# <<< RST# [4]
- ASPDIF <<< ASPDIF [4]
- ALCK <<< ALCK [4]
- ALRCK <<< ALRCK [4]
- ASDAT0 <<< ASDAT0 [4]
- ASDAT1 <<< ASDAT1 [4]
- ASDAT2 <<< ASDAT2 [4]
- ASDAT4 <<< ASDAT4 [4]
- MICMUTE <<< MICMUTE [4]
- MUTE <<< MUTE [4]
- A0\_20 <<< A0\_20 [3]
- AD0\_7 <<< AD0\_7 [3]
- PRD# <<< PRD# [3]
- PWR# <<< PWR# [3]
- PC# <<< PC# [3]
- MA0\_11 <<< MA0\_11 [3]
- BA0\_1 <<< BA0\_1 [3]
- DQ0\_15 <<< DQ0\_15 [3]
- DQM0\_11 <<< DQM0\_11 [3]
- RAS# <<< RAS# [3]
- CAS# <<< CAS# [3]
- CS# <<< CS# [3]
- WE# <<< WE# [3]
- DCLK <<< DCLK [3]
- DCKE <<< DCKE [3]
- SCL <<< SCL [3,4]
- SDA <<< SDA [3,4]
- TV1 <<< TV1 [4]
- TV2 <<< TV2 [4]
- TV3 <<< TV3 [4]
- TWARN1 <<< TWARN1 [4]
- TWARN2 <<< TWARN2 [4]
- TWARN3 <<< TWARN3 [4]
- AMP\_ON <<< AMP\_ON [4]
- AMP\_POW <<< AMP\_POW [4]

CHIP SET MT1379

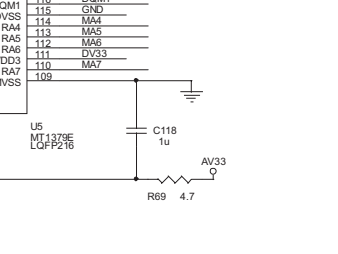
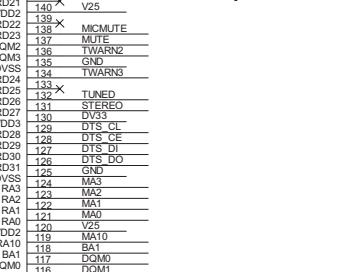
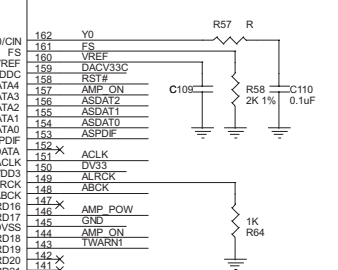

- DTS\_DO <<< DTS\_DO [1]
- DTS\_CE <<< DTS\_CE [1]
- DTS\_DI <<< DTS\_DI [1]
- DTS\_CL <<< DTS\_CL [1]
- TUNED <<< TUNED [1]
- STEREO <<< STEREO [1]
- RDSC <<< RDSC [3]
- RDSO <<< RDSO [3]
- RST# <<< RST# [4]
- ASPDIF <<< ASPDIF [4]
- ALCK <<< ALCK [4]
- ALRCK <<< ALRCK [4]
- ASDAT0 <<< ASDAT0 [4]
- ASDAT1 <<< ASDAT1 [4]
- ASDAT2 <<< ASDAT2 [4]
- ASDAT4 <<< ASDAT4 [4]
- MICMUTE <<< MICMUTE [4]
- MUTE <<< MUTE [4]
- A0\_20 <<< A0\_20 [3]
- AD0\_7 <<< AD0\_7 [3]
- PRD# <<< PRD# [3]
- PWR# <<< PWR# [3]
- PC# <<< PC# [3]
- MA0\_11 <<< MA0\_11 [3]
- BA0\_1 <<< BA0\_1 [3]
- DQ0\_15 <<< DQ0\_15 [3]
- DQM0\_11 <<< DQM0\_11 [3]
- RAS# <<< RAS# [3]
- CAS# <<< CAS# [3]
- CS# <<< CS# [3]
- WE# <<< WE# [3]
- DCLK <<< DCLK [3]
- DCKE <<< DCKE [3]
- SCL <<< SCL [3,4]
- SDA <<< SDA [3,4]
- TV1 <<< TV1 [4]
- TV2 <<< TV2 [4]
- TV3 <<< TV3 [4]
- TWARN1 <<< TWARN1 [4]
- TWARN2 <<< TWARN2 [4]
- TWARN3 <<< TWARN3 [4]
- AMP\_ON <<< AMP\_ON [4]
- AMP\_POW <<< AMP\_POW [4]

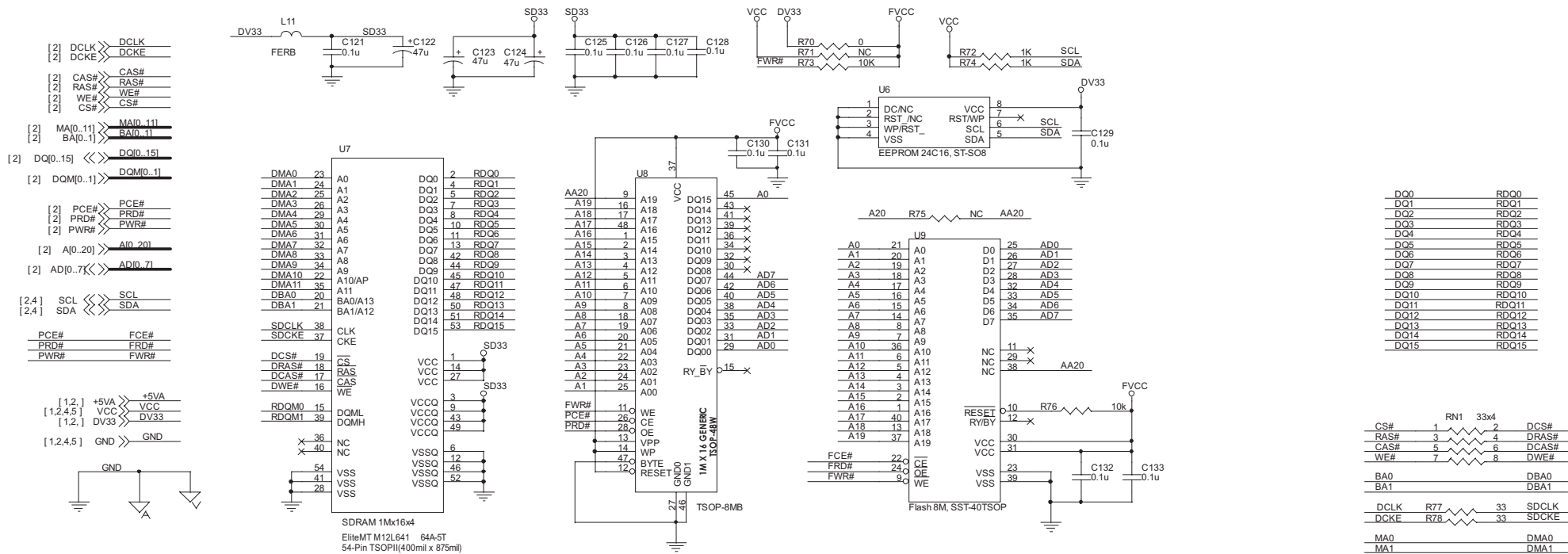

PLL TUN	RDS CE
PLL STE	RDS DI
RDS CLK	RDS SYNC
RDS DATA	DAV INN

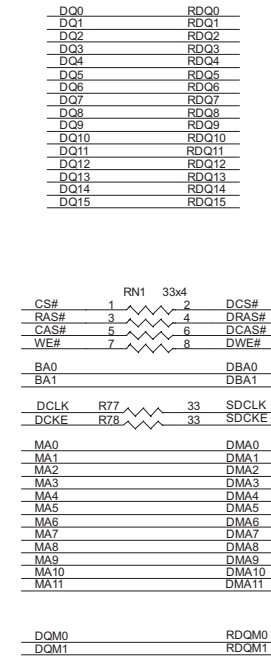
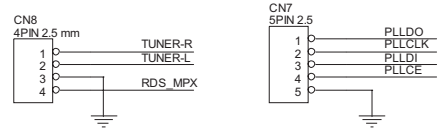
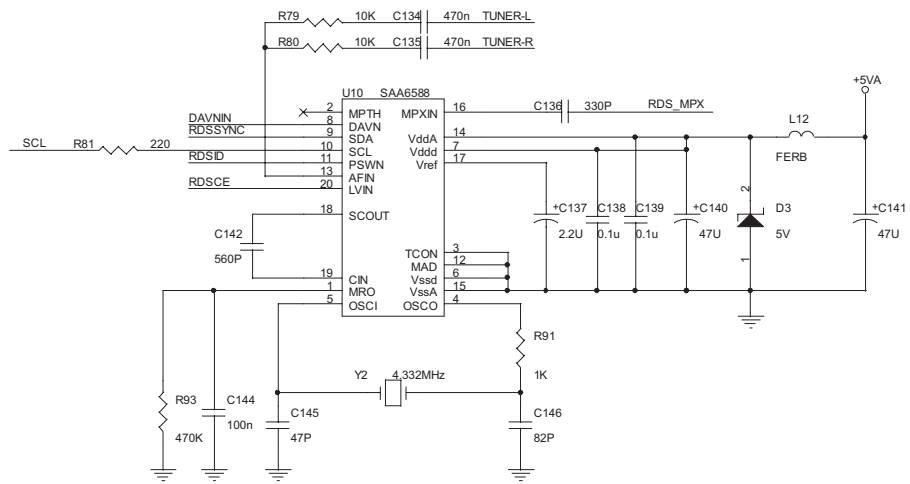
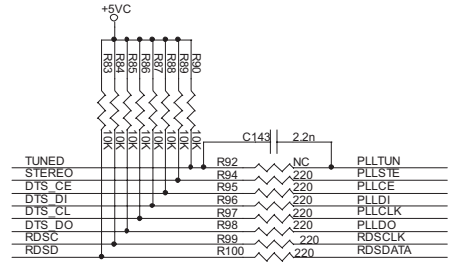

## MEMÓRIAS FLASH E SDRAM

- [1,3.] DV33 >> DV33
- [1] -P12V >> -P12V
- [1] +P12V >> +P12V
- [1,2,3,5] VCC >> VCC
- [1,4] +5VA >> +5VA
- [1,2,3,5] GND >> GND

- [3] TWRN1 >> TWRN1
- [3] TWRN2 >> TWRN2
- [3] TWRN3 >> TWRN3
- [3] AMP\_ON >> AMP\_ON
- [3] AMP\_POW >> AMP\_POW

- [3] ACLK >> ACLK
- [3] ALRCK >> ALRCK
- [3] ABCK >> ABCK
- [3] ASBP0 >> ASBP0
- [3] ASDAT0 >> ASDAT1
- [3] ASDAT1 >> ASDAT2
- [3] ASDAT2 >> ASDAT2

- [3] RST# >> RST#
- [2] MCMUTE >> MCMUTE
- [2] MUTE >> MUTE
- [3] VIDEO\_SL1 >> VIDEO\_SL1
- [3] VIDEO\_SL2 >> VIDEO\_SL2

- [3,4] SCL >> SCL
- [3,4] SDA >> SDA
- GND >> AGND

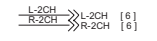
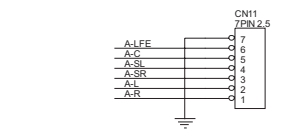
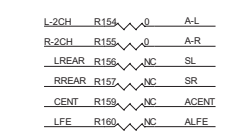
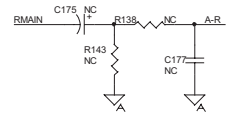
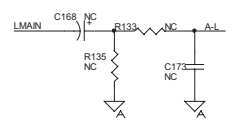
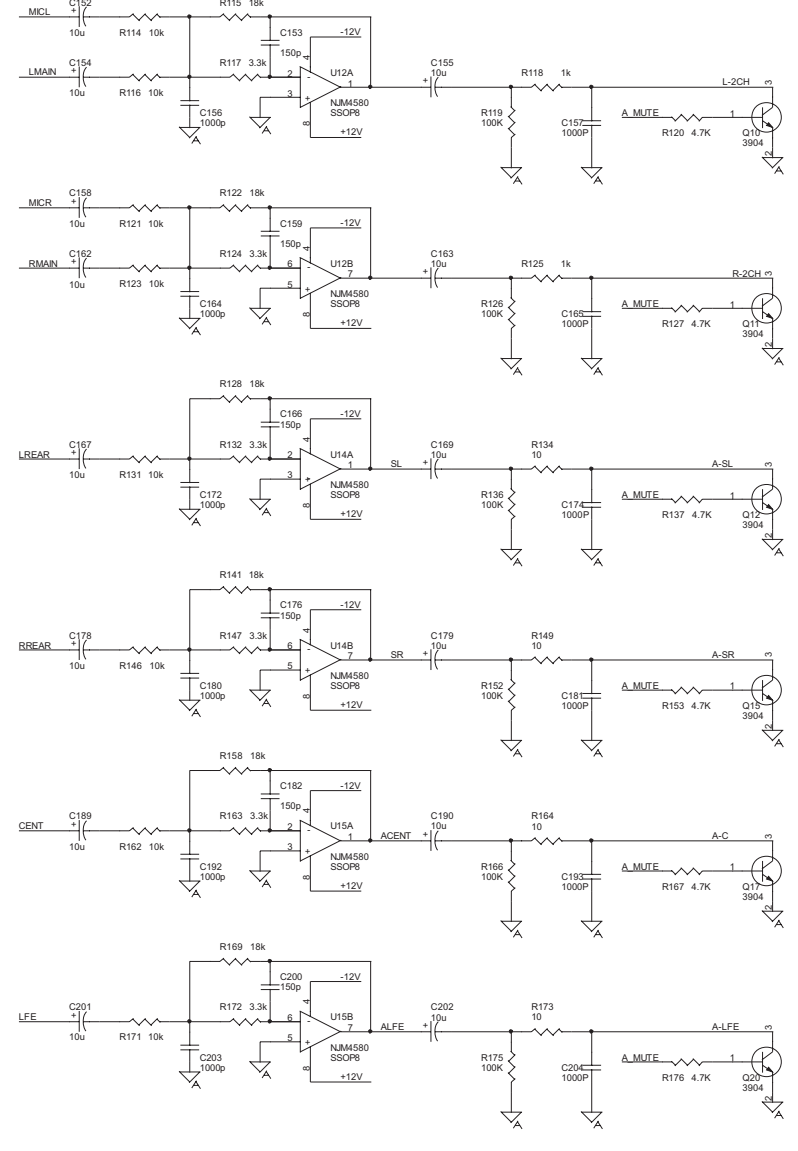
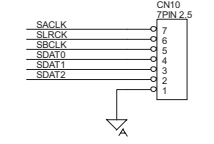
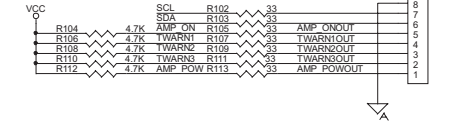
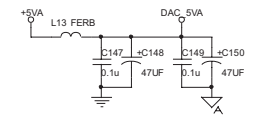
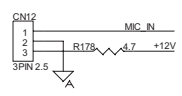
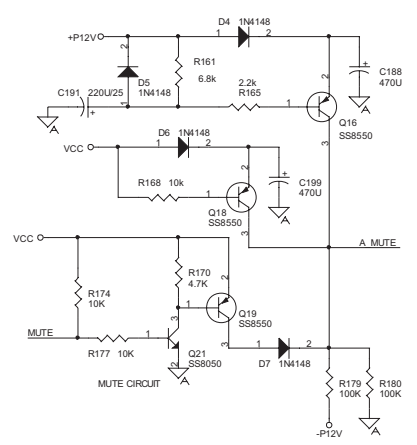
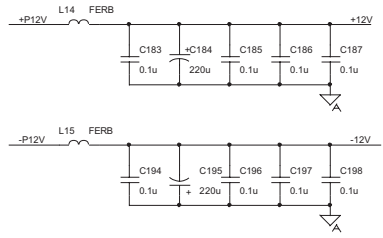
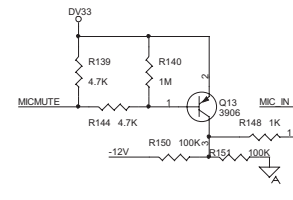
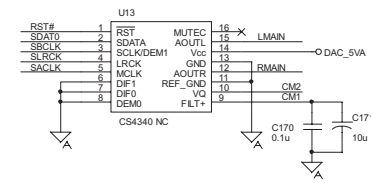
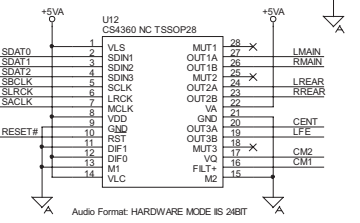
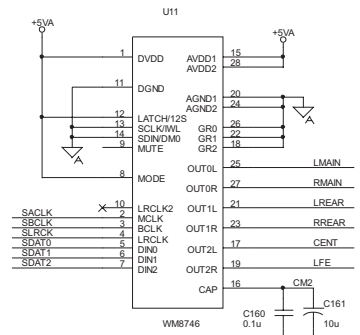

# FILTROS E AMPLIFICADORES DE ÁUDIO E MUTE

[ 1 ] +P12V >> +P12V  
 [ 1,2,3,4 ] VCC >> VCC

[ 3 ] HSYN >> HSYN  
 [ 3 ] VSYN >> VSYN  
 [ 3 ] Y1/C >> Y1/C  
 [ 3 ] Y2/C >> Y2/C  
 [ 3 ] Y3/CVBS >> Y3/CVBS  
 [ 3 ] Y4/G/Y >> Y4/G/Y  
 [ 3 ] Y5/B/U >> Y5/B/U  
 [ 3 ] Y6/R/V >> Y6/R/V  
 [ 3 ] ASPDIF >> ASPDIF

[ 3 ] L-2CH >> L-2CH  
 [ 3 ] R-2CH >> R-2CH

[ 1,2,3,5 ] GND >> GND

GND >> VGND

[ 2 ] TV1 >> TV1  
 [ 2 ] TV2 >> TV2  
 [ 2 ] TV3 >> TV3  
 HSYN >> HSYN  
 VSYN >> VSYN

[ 3 ] VIDEO\_SL1 >> VIDEO\_SL1  
 [ 3 ] VIDEO\_SL2 >> VIDEO\_SL2

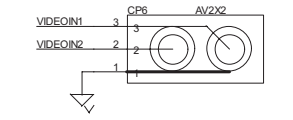
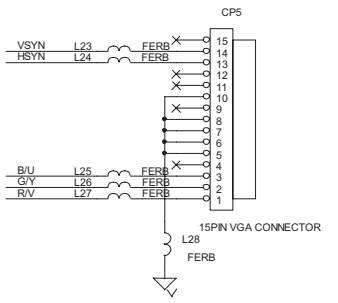
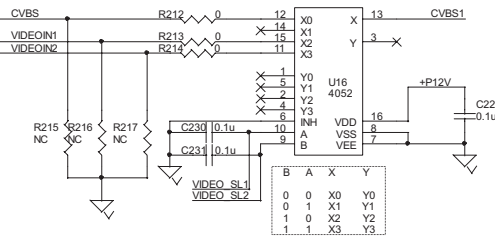
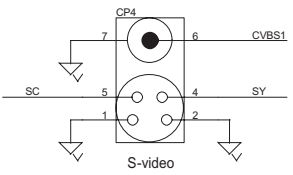
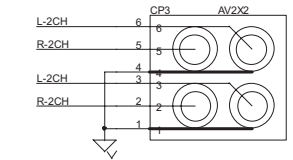
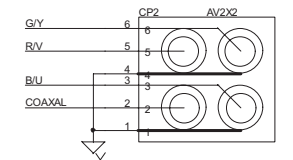
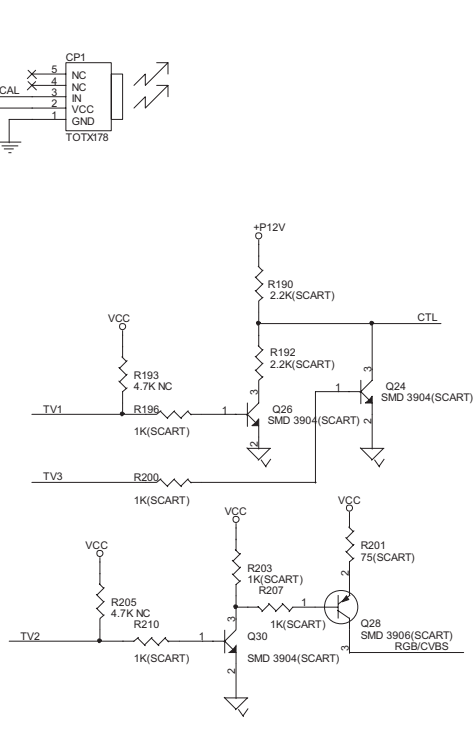
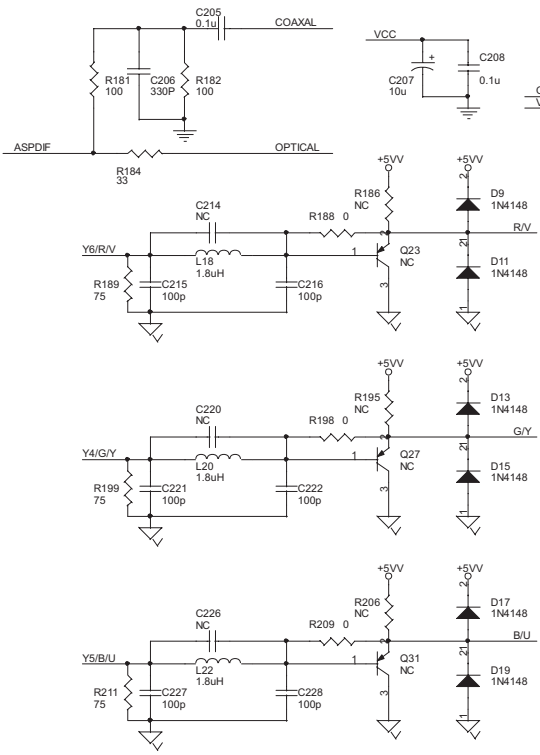
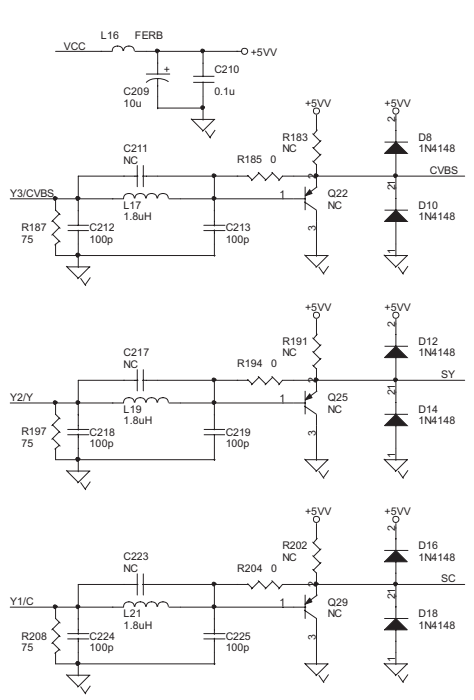

CONECTORES / SAÍDA

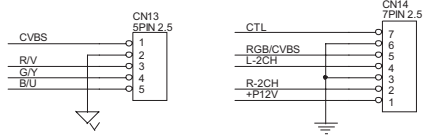
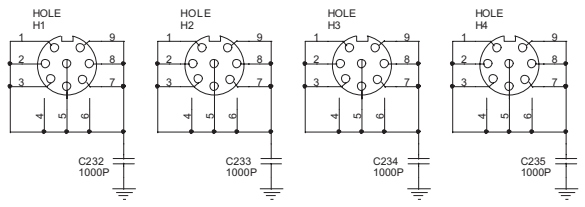

Saalfeld & Freitas / Curitiba

out/2005