

BRYSTON MFG. LTD.

57A WESTMORE DR., REXDALE, ONTARIO, CANADA M9V 3Y6 TELEPHONE: 746-1800, CABLE BRYREXCAN

BRYSTON

2B

POWER AMPLIFIER

Technical Data And Parts List

Bryston 2B Specifications

Specifications.	Basic Stereo Power Amplifier.
POWER	50 watts per channel, 8 ohms. 100 watts per channel, 4 ohms. 200 watts, bridged, 8 ohms.
DISTORTION	
Harmonic:	Less than 0.01% from 20 to 20kHz at 50 watts.
IM:	Less than 0.01% from 10 milliwatts to 50 watts.
Noise:	100 db below full output.
Crosstalk:	Below noise 20 to 20kHz at 50 watts.
SLEWING RATE:	Greater than 60 volts per microsecond.
POWER BANDWIDTH:	Less than 1 Hz to over 100 kHz.
DAMPING FACTOR:	Over 500 at 20 Hz, ref. 8 ohms.
INPUT SENSITIVITY AND IMPEDANCE:	75 volt for full output, 50k ohms.
FEATURES:	<ol style="list-style-type: none">1. Bridging switch.2. Over 250 sq. in. of heat-sinking.3. Regulated power supplies to all voltage gain stages.4. Each channel separated back to the linecord.5. Dual-colour LED pilotlights and clipping indicators; green changing to red at clipping.6. Will deliver full output to any phase angle at 4 OHMS or higher.7. Warranty: 3 years parts and labour, shipping one way.
DIMENSIONS:	19" x 3½" x 10", wt. 20 lbs.

BRYSTON MFG. LTD.

57A WESTMORE DR., REXDALE, ONTARIO, CANADA M9V 3Y6 TELEPHONE: 746-1800, CABLE BRYREXCAN

- 2 -

- 7) A. Re-insert 20K hz. signal to channel input and adjust level to clip amplifier. Clipping should be symmetrical and clipping indicator (red LED) should turn on.

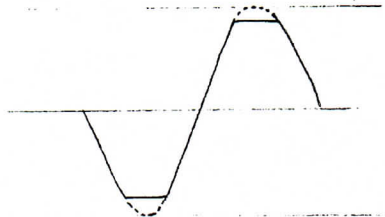

- B. Reduce input signal to bring amplifier just below the threshold of clipping and measure output power.

<u>Voltage (rms)</u>	<u>Power (watts) into 8 ohms</u>
20	50
21	55
22	61
22.2	62
22.4	63
22.6	64
22.8	65
23	66
23.2	67
23.4	68
23.5	69
23.7	70

- C. Reduce input signal 1.5db (approx.) or to 20V(rms) to bring amplifier down to full rated output power (50 watts).

- 8) Momentarily place a non-polar, 5u6/100V capacitor across output terminals to engage protection circuitry.

Sine wave should be converted to a symmetrical triangle wave. If triangle wave is shifted more than approx. 30°, protection circuitry is malfunctioning.



- 9) THD should be below .02% at 20K hz, at 50 watts output.
- 10) Noise - referenced to full rated output; unweighted noise should be greater than -100db.

BRYSTON MFG. LTD.

57A WESTMORE DR., REXDALE, ONTARIO, CANADA M9V 3Y6 TELEPHONE: 746-1800, CABLE BRYREXCAN

- 2 -

- 7) A. Re-insert 20K hz. signal to channel input and adjust level to clip amplifier. Clipping should be symmetrical and clipping indicator (red LED) should turn on.

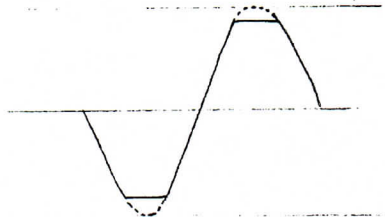

- B. Reduce input signal to bring amplifier just below the threshold of clipping and measure output power.

<u>Voltage (rms)</u>	<u>Power (watts) into 8 ohms</u>
20	50
21	55
22	61
22.2	62
22.4	63
22.6	64
22.8	65
23	66
23.2	67
23.4	68
23.5	69
23.7	70

- C. Reduce input signal 1.5db (approx.) or to 20V(rms) to bring amplifier down to full rated output power (50 watts).

- 8) Momentarily place a non-polar, 5u6/100V capacitor across output terminals to engage protection circuitry.

Sine wave should be converted to a symmetrical triangle wave. If triangle wave is shifted more than approx. 30°, protection circuitry is malfunctioning.



- 9) THD should be below .02% at 20K hz, at 50 watts output.
- 10) Noise - referenced to full rated output; unweighted noise should be greater than -100db.

VP

BRYSTON MFG. LTD.

57A WESTMORE DR., REXDALE, ONTARIO, CANADA M9V 3Y6 TELEPHONE: 746-1800, CABLE BRYREXCAN

BRYSTON 2B POWER AMPLIFIER

BURN-IN PROCEDURE

All power amplifiers are 'burned-in' for approximately four days in the mono mode, using a capacitive load of 330nf (200V) across the two speaker hot (red) terminals, (preferably with a fuse in series), and bias is initially set at 6mv to 8mv.

A 3K hz. square wave signal is fed into the amplifier's left channel input at a level sufficient to produce 50 VAC - as measured with an 'averaging' voltmeter - across the two hot (red) output terminals, for three out of every four hours during burn-in period. Chassis tops are left off amplifiers during burn-in.

After three full days of burn-in, 3K hz. square wave input signal and capacitive load are removed, and chassis top is put on amplifier. Bias is reset to 10mv to 12mv.

Bias is rechecked every few hours until it has stabilized at 10mv. to 12mv. No further bias adjustments will then be made.

N.B. Line voltage should be stable while bias is being set.

COMPONENTS SHOWN WITHIN DASHED
LINES ARE ON COMMON HEATSINK

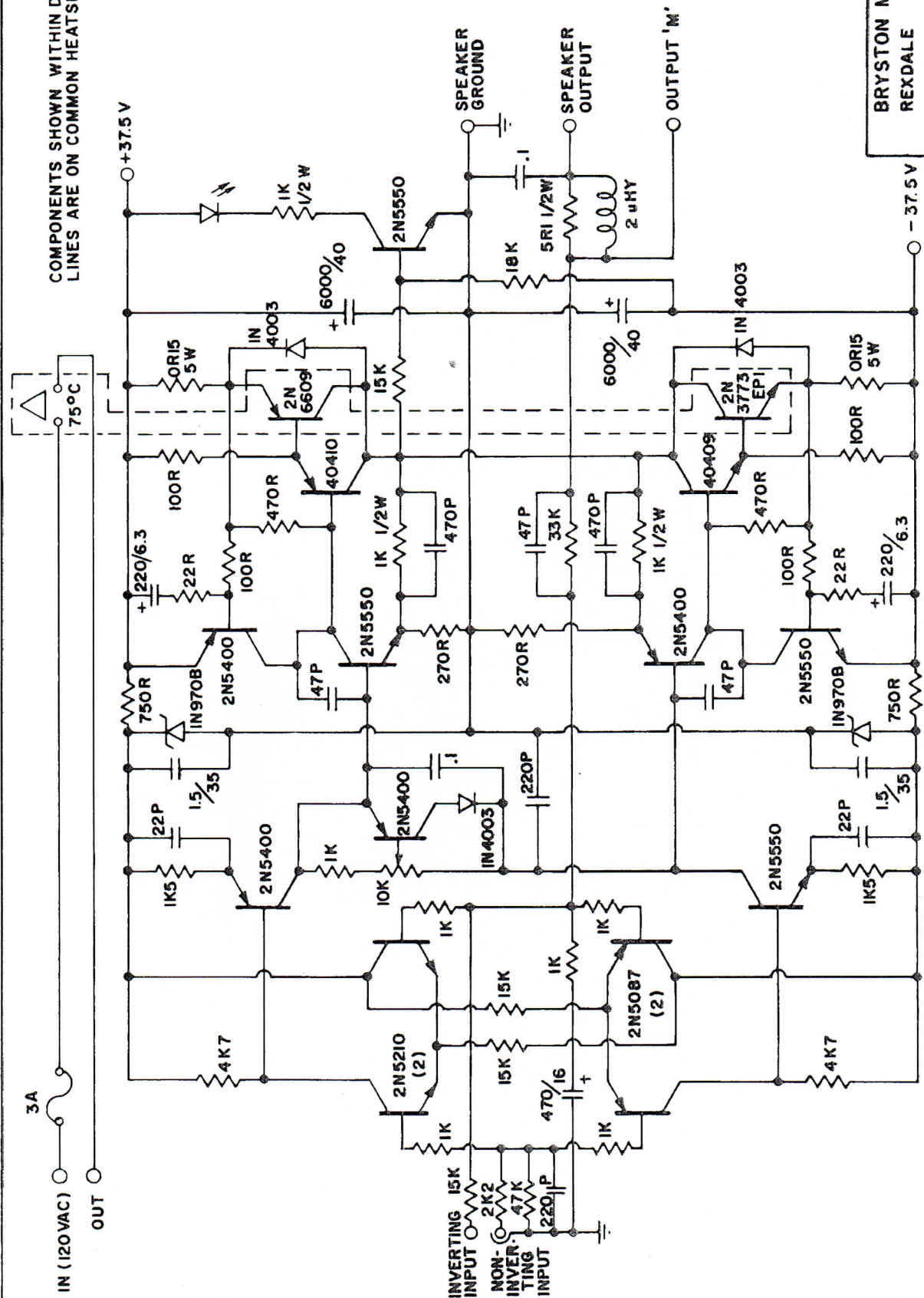

BRYSTON MFG. LTD.
REXDALE ONT.

TITLE MODEL 2B POWER
AMPLIFIER MAIN BOARD
SCHEMATIC DIAGRAM

DWN. J.K	DATE 10/12/79	REV. N°
-------------	------------------	------------

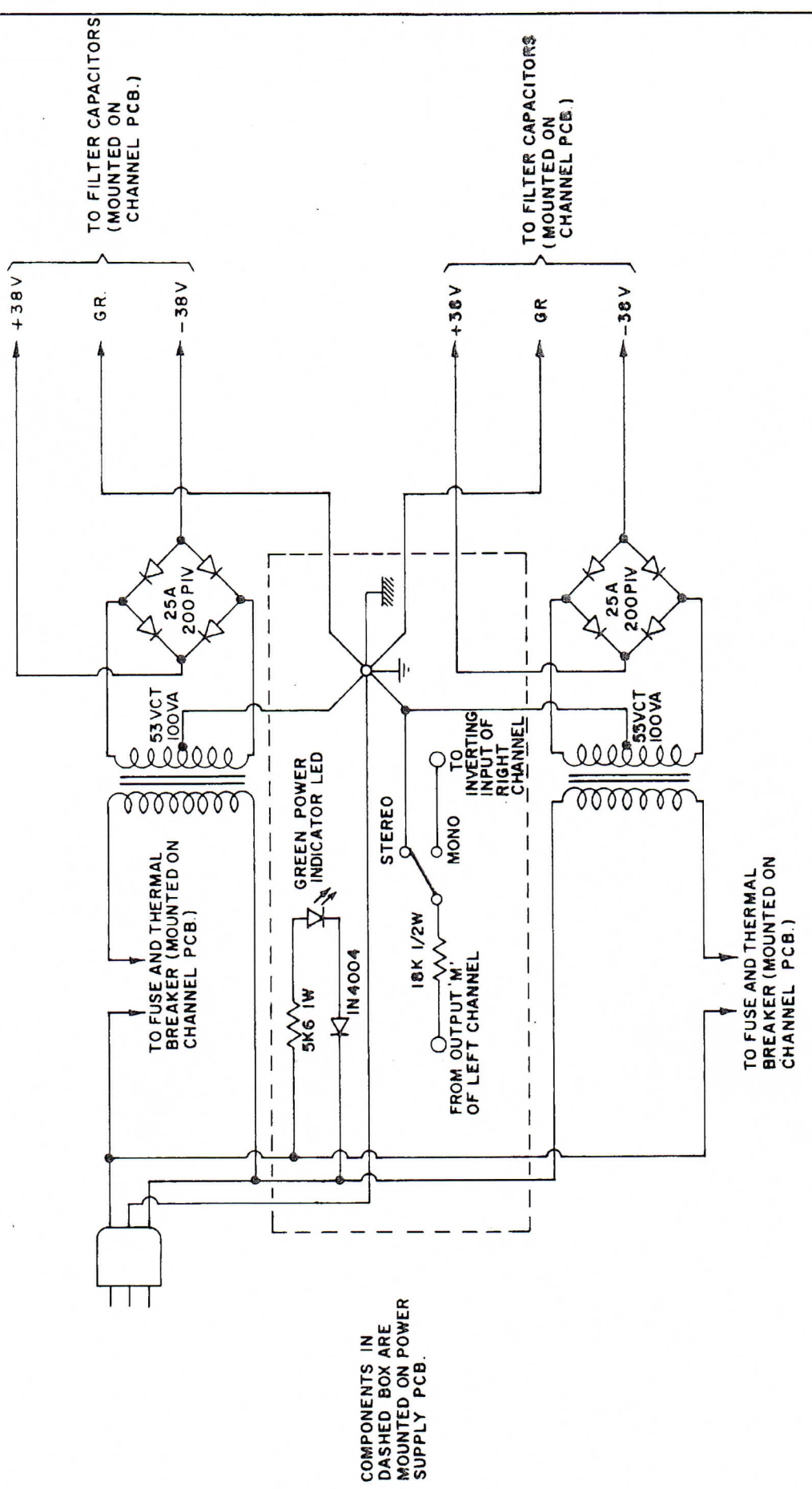

COMPONENTS IN DASHED BOX ARE MOUNTED ON POWER SUPPLY PCB.

BRYSTON MFG. LTD. REXDALE ONT.	
TITLE MODEL 2B POWER SUPPLY SCHEMATIC DIAGRAM	
DWR.	DATE
J.K	19-12-79
REV.	N ²