



ALL RESISTORS ARE 0.6 WATT 1% EXCEPT WHERE NOTED.	
REVISION HISTORY	
INPUT SEL	EDGE CONNECTOR P1
REG ①	① ← PN #
PRO+60B ②	
UNBAL ③	

BRYSTON LTD
 677 NEAL DR. PETERBOROUGH, ONTARIO CANADA K9J 7Y4
 PHONE (705) 742-5325 FAX (705) 742-0882

9B CHANNEL SCHEMATIC

9B CHANNEL ASSEMBLY

FILE: PWRSCH9B PART No: 9B-MB-R2.4

DATE: MAY 98	DWG BY: 	REV: 2.4
--------------	---	----------

POWER / REMOTE / MUTE

POWER SUPPLY AND LOGIC FOR 9BST R6
 FILE: 9BSSBSCH6 PART No: 9BREMSSB6

DATE: OCT 99 DWG BY: **ST** REV: 6

RESISTORS ARE .6 WATT METAL FILM UNLESS NOTED	1N4688 = 4.7V
= FASTON QUICK DISCONNECT	1N4733 = 5.1V
= BOARD TO BOARD INTERCONNECT	1N4737 = 7.5V
= BOARD EDGE CONNECTOR	1N4740 = 10V
	1N4741 = 11V
	1N4745 = 15V
	1N4752 = 33V

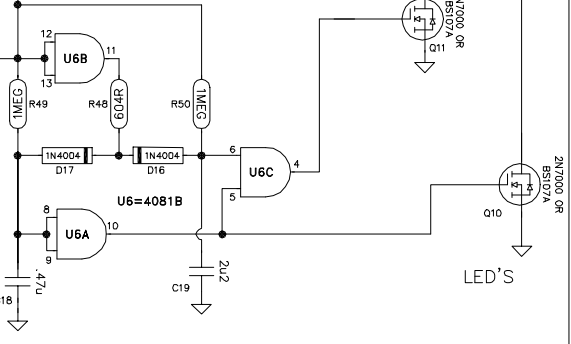
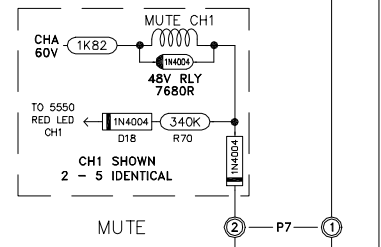
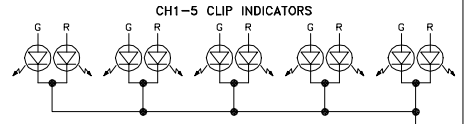
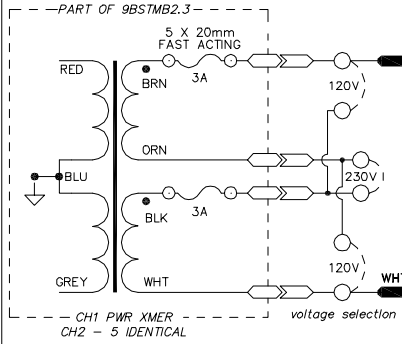
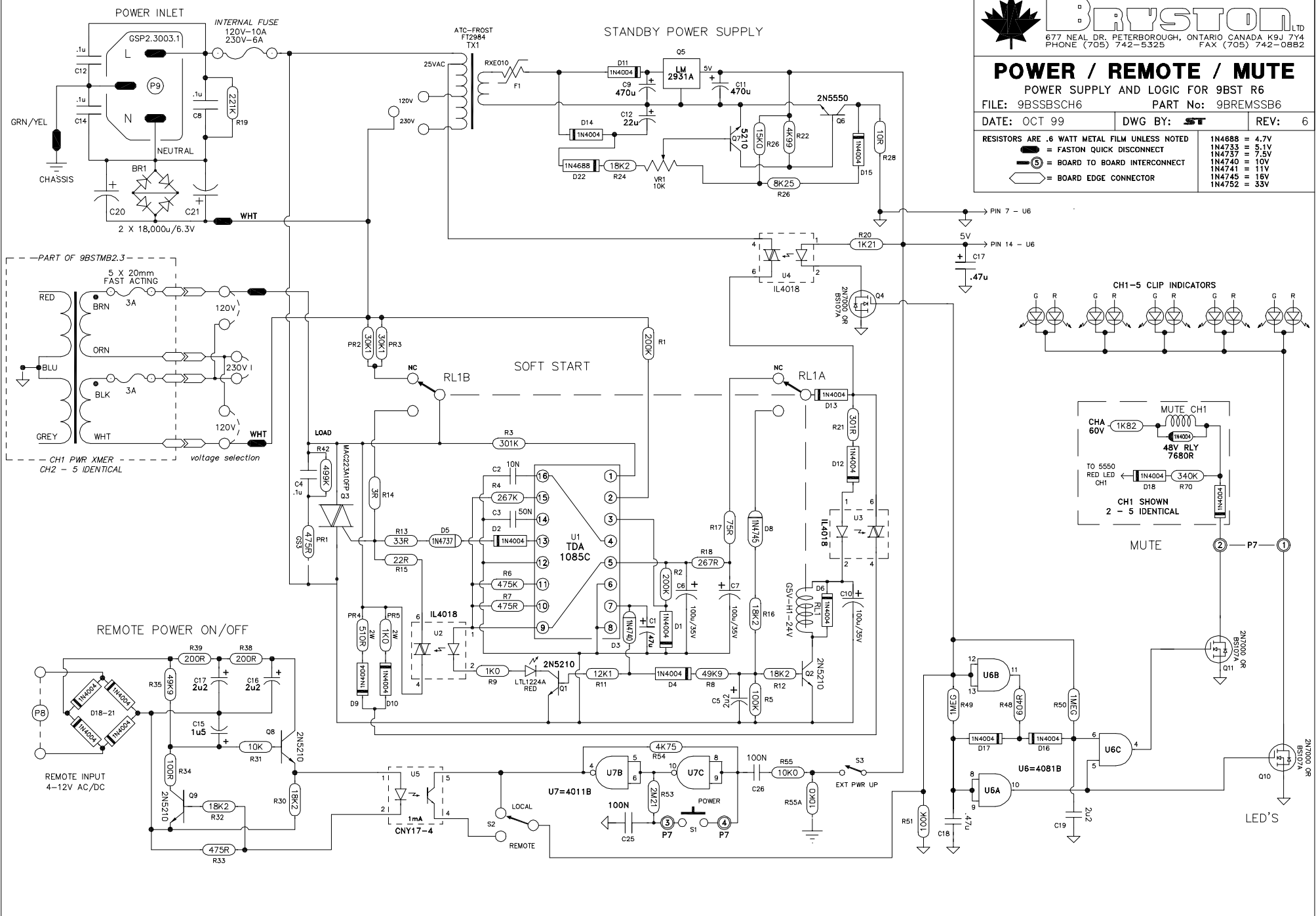

9B ST Amplifier Specifications



19" faceplate with handles



17" faceplate THX version

9B ST 5-Channel Modular Amplifier

Description	<p>Bryston's 9B ST five-channel amplifier is an extremely versatile and flexible amplifier for integrating audio/video systems requiring multiple channels of amplification.</p>
Watts	<ul style="list-style-type: none"> Five channels at 120 watts, 8 ohms / 200 watts, 4 ohms
Distortion	<ul style="list-style-type: none"> Less than 0.007% from 20Hz to 20kHz at 120 watts, IM or THD
Noise	<ul style="list-style-type: none"> 110dB below full output, 20Hz - 20kHz
Slewing rate	<ul style="list-style-type: none"> Greater than 60 volts per microsecond
Power bandwidth	<ul style="list-style-type: none"> 0.5Hz to over 100kHz
Damping factor	<ul style="list-style-type: none"> Over 500 at 20Hz, ref. 8 ohms
Input sensitivity & impedance	<ul style="list-style-type: none"> 1.0V = 100 watts, 8 ohms, unbal. THX position 1.0V = 100 watts, 8 ohms, bal. +6 position 2.0V = 100 watts, 8 ohms, bal. reg. position or bal. THX position 50K unbalanced, 15K balanced
Features	<ul style="list-style-type: none"> Five channels in a single compact chassis Modular construction for quick and easy service Balanced or unbalanced operation at the flick of a switch 3-position input selector switch selects balanced, balanced +6 or unbalanced position Gold-plated custom 5-way binding posts, RCA and XLR connectors Totally separate and independent power supplies for each channel Remote 12-volt trigger (THX certified version) <p>Warranty: 20 years parts and labour, shipping one way</p>
Dimensions	<p>19 x 5.25 x 16 inches, 48.25 x 13.33 x 42 cm; wt: 65lbs, 29.5 kg</p>
Options	<ul style="list-style-type: none"> 17 inch version available THX version available pro version available; standard with adjustable gain control per channel

BRYSTON OWNER'S MANUAL

Instructions For Bryston

ST Series Amplifiers

Model 9B ST

GENERAL INSTRUCTIONS

Warranty Information:

Thank you for choosing a Bryston product. We welcome any suggestions you may have, or comments regarding the operation of your amplifier. We consider you, our customer, to be Bryston's most important resource, and your opinion is very much appreciated.

Bryston products are warranted to be free from manufacturing defects for a minimum of 20, (twenty), years from the original date of manufacture. This includes all parts, labor and one-way return shipping. This warranty covers the original owner and any subsequent owners. The warranty is retroactive for any Bryston product purchased within the last twenty years. Tamper-

ing by anyone other than factory authorized personnel voids the warranty. Warranty service may be obtained by returning the unit to any authorized Bryston dealer or distributor. You may also contact the Bryston factory or national service offices directly at the location listed on the rear page of this manual.

Please keep the original box and all packing material. This will ensure the amplifier is protected in the unlikely event you have a problem and must return it for service. No warranty card is necessary to initiate your coverage. Please refer to the back page for more detailed warranty information.

Bryston 9B-ST Amplifier Description:

The Bryston 9B-ST is a multi-channel power amplifier consisting of five independent amplifier modules, each with its own power transformer and +/-60V power supply. Each audio channel provides connections for balanced or

single ended input and will supply a minimum of 120 watts of power into 8 ohms or 200 watts into 4 ohms.

A remote power control option is available on THX versions.

Installation Setup And Recommendations:

➔ PROVIDE ADEQUATE VENTILATION

Do not place the amplifier in an enclosed un-ventilated area. Allow at a minimum, 3 inches of space at the top, sides and back as your amplifier relies on convection cooling and ample air flow is required. Be sure cool air can flow freely through the amplifier. Do not install near heat sources such as other power amplifiers, hot air vents, radiators, etc.

All Bryston amplifiers contain high quality, dedicated circuitry in their power supplies to reject RF, line spikes and other power-line problems. Bryston power amplifiers do not require any specialized

power line conditioners. Simply plug the amplifier directly into its own wall socket.

Make sure the power switch on the front of the amplifier is in the off (out) position. Plug the power cord (female end) into the rear of the amplifier, then insert the male end into the wall outlet. Finally, upon completion of the installation activate the 9B power switch only after all other equipment is powered up.

Note:

If rack-mounting the 19 inch version please ensure that the rear of the 9B is well supported.

PLEASE REFER TO: "BRYSTON'S SAFETY MANUAL" FOR FURTHER OPERATING INSTRUCTIONS.

BRYSTON 9B ST MANUAL

9B ST Rear Panel

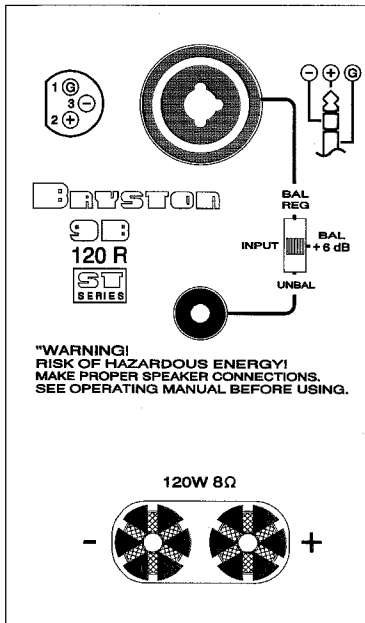

Input:

The **9B** has two inputs, one for a balanced source, and one for single ended or un-balanced source. The BAL input connector will accept either a 3 pin 'XLR' type or a 1/4" Tip/Ring/Sleeve type. The in phase (+) terminal is pin 2 on the 'XLR' and tip on the TRS. The input impedance is 15K ohms. The input pins are gold plated. Input sensitivity is selectable using the 'INPUT' slide switch. In the 'BAL REG' position 2 Volts in = 100 Watts / 8 ohms output. This is the *recommended setting* when using **Bryston** pre-amplifiers or

any pre-amplifier having active balanced outputs. This setting also produces the lowest amplifier noise floor.

The 'BAL +6 dB' setting adds 6 db of gain to provide an input sensitivity of 1 Volt in = 100 Watts / 8 ohms output. This setting is primarily for balanced outputs that are transformer coupled, or other low level sources. The 'UNBAL' setting selects the gold plated 'RCA' type tip/sleeve connector. The input impedance is 50K ohms. The output is in phase with the input and the sensitivity is 1 Volt in = 100 Watts into 8 ohms output.

Balanced Vs Unbalanced:

Balanced cable interconnects should be used whenever possible, as they provide common mode noise protection from external electrical interference, and with active balanced outputs a 6 dB higher signal level flows in the cable.

The unbalanced cable interconnect is provided for pre-amplifiers without balanced output. Unbalanced cables should be kept to 10 feet or less. In general never use longer cables than necessary, never coil excess cable length, and run signal wires away from and never parallel to AC power or speaker cables.

Output:

Gold plated output binding posts provide three different interconnect options. Stripped bare wire up to 8 Ga. can be passed through the hole in the binding post and held in place by tightening the post knob. Additional tightening pressure can be achieved using a coin in the slots of the knob. Copper wire is malleable and may require further tightening a month or

two after initial installation. When using bare wire watch out for fine wire fragments shorting from one wire to the other.

Wire terminated with banana plugs, spade lugs, or pins are also accommodated by the binding posts. **We recommend gold plated connectors to prevent corrosion and signal distortion.**

The **red (+)** binding post is the output and normally will be connected to the red (+) connector on the loudspeaker. The **black (-)** binding post is ground and should be connected to the **black (-)** connector on the loudspeaker. Speaker wire should be kept as short as practical and should never be terminated with connectors that may become confused with AC power connectors. Speaker cables should be dressed away from input and power cables, and even each other when runs are long.

→ **The minimum speaker load on the amplifier is 4 ohms.**

BRYSTON 9B ST MANUAL

Clipping Indicators:

All Bryston amplifiers use bicolor LEDs with green indicating power on and flashing red indicating actual overload or distortion. Upon power-up the 9B's LED's will remain "red" until all voltages stabilize and the unit comes out of mute and the LED turns green.

If the LED indicator contains a substantial red content, when program is present, it should be considered as a sign that the level is too high and may cause speaker damage if it continues. It should be remembered that the Bryston ST series are powerful amplifiers, and that it is possible to damage almost any speaker if an amplifier is used in a thoughtless or abusive manner. Brys-

ton will not be responsible for damage caused in this manner.

The clip-sensing circuit uses an AC comparator to detect any source of signal distortion including clipping, short circuits in cabling, excessive DC or supersonic signals, whether at the input or output. Most conditions which could cause the red LED to light for more than a moment or two can be dangerous to your loudspeakers and should be corrected immediately.

- ***If a specific LED remains "red" without signal present, it may indicate a thermal overload condition and the channel is shut down until safe operating temperatures return.***

Bryston 9B ST Remote Power Control - THX units only

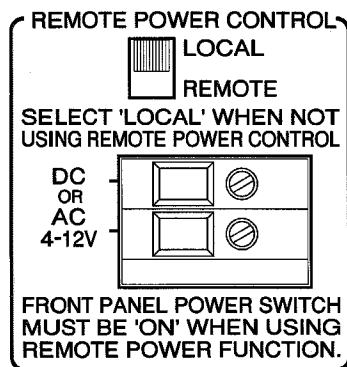

The 9B ST remote power control function allows the user to link the power on/off of the 9B to an external preamplifier, processor, or other control device. This is useful in installations, such as home theater, for powering up multiple amplifiers, often at distant locations from the source.

Located on the back panel of the 9B ST is a two screw terminal input connector. The amplifier

can be powered-up by applying 4-12 Volts (AC or DC of either polarity) connected to the terminals of the jack. This jack will accept 1/4 inch stripped wire ends, inserted into the square holes provided, and the adjacent screws carefully tightened to hold them in place. The input current remains at less than 3 ma regardless of voltage, therefore 22 Ga wire is sufficient.

- ***The front panel power switch must be left in the "on" position (in), at all times for the amplifier to operate in remote power control mode.***
- ***In 'REMOTE' position the amplifier can only be turned on by applying a remote control voltage of 4-12 volts.***
- ***In the 'LOCAL' position the amplifier will not respond to remote control voltage, only the front panel power switch.***
- ***At all times the power can be turned off by using the front panel power switch.***

BRYSTON 9B ST MANUAL

Typical Surround Sound Hookup:

Shown below: is a typical hookup between a surround sound processor and the 9BST. We show balanced interconnects which we recommend especially when the 9B is located more than 10 feet from the processor. The connections would be similar using the unbalanced interconnects. This suggested layout when viewed from the front of the 9B has the center channel in the middle and left and right front channels adjacent to the center with left

and right surround speakers juxtaposed to the appropriate left and right front channels. This particular setup allows you to easily monitor the status of each individual channel as the power LED's will correlate with the positions of the speakers in most rooms (see diagram below). It should be noted that because each channel on the 9B is identical any channel can be operated with any input and arranged as required.

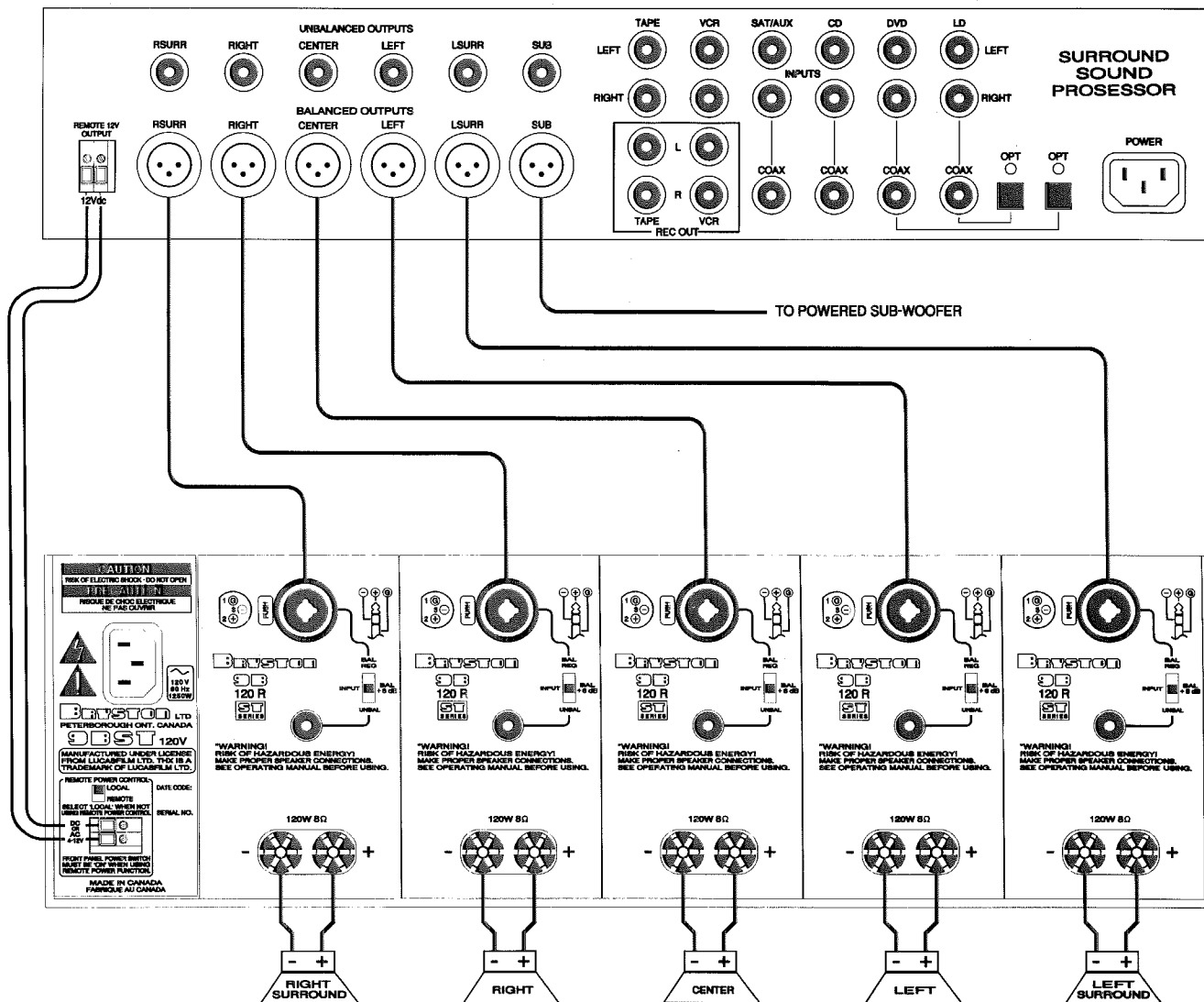

BRYSTON 9B THX AMPLIFIERS

For Bryston amplifiers with rear panel gain adjustment including the THX designation the correct THX position is as indicated on the back panel.

9B-ST THX

The "BAL THX" or the "UNBAL THX" position (see diagram) is the correct setting for the slide switch (see diagram) is the correct setting for the slide switch. Do not place the slide selector in the middle or +6 dB position if installed in an authorized THX system.

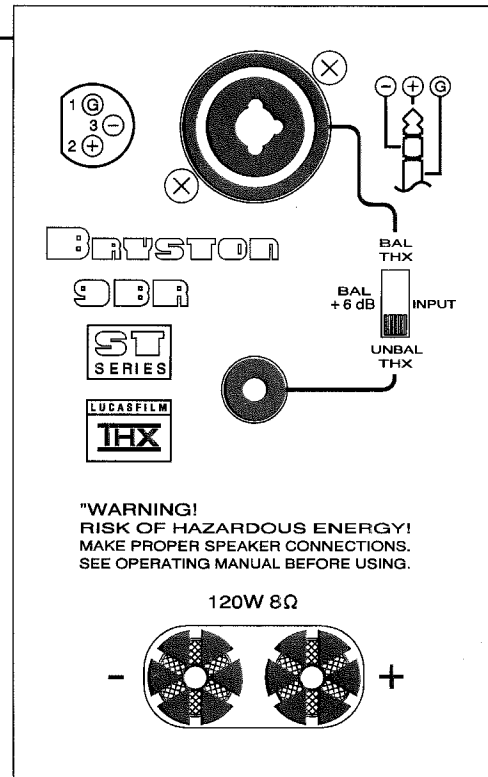

9B PRO THX

The 9B professional version provides a rotary gain control which must be turned fully clockwise if installed in a THX system and the slide switch above (see diagram) must also be in either the "BAL THX" or "UNBAL THX" position.

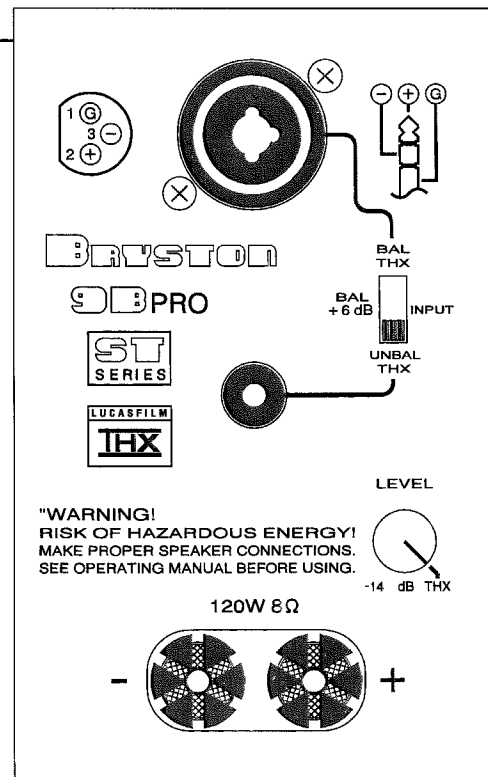

BRYSTON

P.O. Box 2170, 677 Neal Drive,
Peterborough, Ont., Canada K9J 7Y4
Tel: (705) 742-5325 • Fax: (705) 742-0882

BRYSTON 20-YEAR WARRANTY

Bryston products are warranted to be free from manufacturing defects for a minimum of twenty years from the original date of manufacture. This includes parts, labour and return shipping to the first owner and all subsequent owners. Warranty coverage is automatic and commences with the original date of manufacture which is kept on file at Bryston.

In the event of a defect or malfunction, Bryston will remedy the problem by repair or replacement, as we deem necessary, to restore the product to full performance.

This warranty is considered void if the defect, malfunction or failure of the product or any component part was caused by damage (not resulting from

a defect or malfunction) or abuse while in the possession of the customer. Tampering by persons other than factory authorized service personnel, or failure to fully comply with Bryston operating instructions, voids the warranty.

This warranty gives you specific legal rights and you may also have other rights which may vary from province to province and country to country.

FOR BRYSTON SERVICE OUTSIDE CANADA:
CONTACT YOUR LOCAL DISTRIBUTOR
OR CHECK OUR WEB SITE AT:
www.bryston.ca
OR CALL BRYSTON DIRECTLY AT:
PHONE: 705-742-5325
FAX: 705-742-0882

BRYSTON SERVICE CANADA:
24 STEINWAY BLVD., UNIT 48
ETOBICOKE, ONTARIO
CANADA M9W 6T8
PHONE: 416-675-2585
FAX: 416-675-3103

BRYSTON LTD.
P.O. BOX 2170, 677 NEAL DRIVE
PETERBOROUGH, ONTARIO
CANADA K9J 7Y4
PHONE: 705-742-5325
FAX: 705-742-0882

BRYSTON SERVICE U.S.A. :
30 COVENTRY ST.
NEWPORT VERMONT.
U.S.A. 05855
PHONE: 802-334-1201
FAX: 802-334-6658

Specifications: 9B-120-R channel		9B-120-P channel	
power rating:	120 Watts into 8 Ω 200 Watts into 4 Ω	The 9B-PRO version provides for input attenuation of up to 14dB by adjusting the 'LEVEL' control. Full attenuation versions are also available. Level controls are not available on THX versions.	
input impedance:			
balanced	15 k Ω	THX	
unbalanced	50 k Ω		
sensitivity:		THX MODELS ARE MANUFACTURED UNDER LICENSE FROM LUCASFILM LTD. THX IS A TRADEMARK OF LUCASFILM LTD.	
bal input reg	2 Volt in = 100 Watts / 8 Ω		
bal input +6	1 Volt in = 100 Watts / 8 Ω		
unbal	1 volt in = 100 Watts / 8 Ω	dimensions	
distortion:			
Thd + N	.007% 20Hz to 20kHz at 120 Watts / 8 Ω	rack mount models	19" x 17" x 5.25"
IMD	.002% 60 Hz + 7kHz mixed 4 to 1	17" models	17" x 17" x 5.25"
noise	-107db 20Hz to 22kHz bandpass	shipping weight	75 lbs
power consumption:			
all channels at full power with 8 ohm loads = 900 VA.			
all channels at full power with 4 ohm loads = 1600VA.			
all channels idle = 100 VA.			

**HEIGHT of "ST" SERIES POWER AMPLIFIERS
 when equipped with different feet**

