

Accuglide[®]

XR-50

OWNER'S MANUAL

Thank you for selecting the BSR ACCUGLIDE XR-50. You are now the owner of the only Fully Automatic Programmable Belt Driven Turntable with Microprocessor Drive and Memory Bank.

To insure your complete satisfaction and years of trouble-free service, we strongly recommend that you take a few minutes to read the instructions which follow, before attempting to install your turntable.



DESIGN AND OPERATING FEATURES

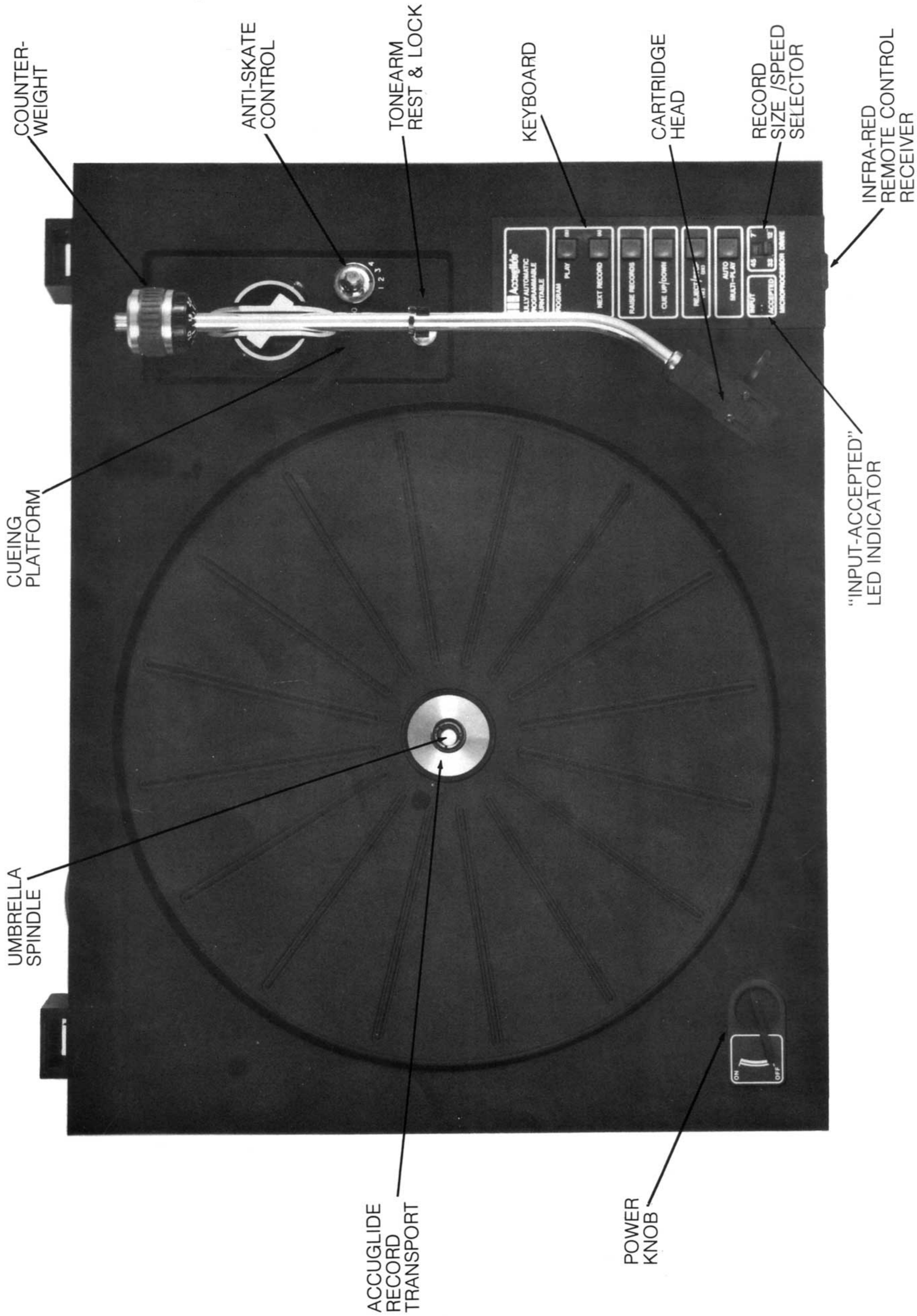

Contents

Specifications	1
Unpacking	1 & 2
Placement & Installation	2
Assembly	2
Connections	3
Control Panel Functions	4

Operating Instructions	5
Program Operation	5
Auto Multi-Play Operation	6
Remote Control Operation	7
Common Sense Trouble Shooting	8
Stylus Installation	8
Important Safeguards	9

Technical Specifications

Turntable System

- Type: Two Speed Belt Drive
- Motor Drive System 300 rpm Low Speed, Electronically Controlled A.C. Synchronous 24-Pole Motor
- Speeds:
33 $\frac{1}{3}$ and 45 rpm
Electronically Controlled Speed
- Build Up Time:
Under 2 Seconds to Full Speed
- Turntable Platter:
Diameter 302mm (11 $\frac{7}{8}$ "")
- Wow and Flutter:
Less than .04% W.R.M.S.
- Rumble:
Better than -66dB (DIN 45539B)

Tone Arm System

- Type: Tubular "J" Shaped Statically Counter-Balanced Arm, Calibrated Stylus Pressure Dial
Decoupled Counterweight, Electronically Controlled Cue (Pause), Muting and Anti-skate Control
- Effective Length:
221 mm (8.7"") Pivot to Stylus Tip
- Overhang: 19 mm (.750"")
- Friction: 9-10 Milligrams Horizontally and Vertically
- Offset Angle: 25°
- System Resonance:
10-12 Hz (with ADC QLM 32 MKIII Cartridge Supplied)
- Tracking Force Range 0-4 Grams (with QLM 32 MKIII Cartridge supplied, Operate at 2-4 Grams)
- Wire Capacitance: Less than 20 pf per Channel

Cartridge System

- Type: ADC QLM 32 MK III, Low mass, Induced Magnet (U.S. Patent 3294405)
High Energy Magnet Structure
- Output 1.5 mV/cm/Sec.
- Tracking Force Range 2-4 Grams
- Frequency Response 20Hz to 18kHz \pm 2dB.
- Channel Separation: 20dB
- Load Resistance 47K OHMS
- Stylus Tip: .0004" \times .0007" Bushed Elliptical Diamond

General

- Power Requirements:
120 V.A.C. 50/60Hz
- Power Consumption: 12 Watts
- Accessories Included:
BSR TX-20 Infra-Red Remote Control Transmitter (Includes Remote Volume Control Feature)
9 Volt Battery
Removable Hinged Dust Cover
Rotating Manual Play Spindle
45 RPM Adaptors
Stylus Brush
48" Dual Shielded Phono Cables
Transit Screw Key
- Features:
Accuglide Record Transport System
Remote Volume Control
Acoustically Inert Anti-Resonant Cabinet

Dimensions

Left to Right = 453mm (17 $\frac{7}{8}$ "")
Front to Back = 370mm (14 $\frac{1}{2}$ "")
Height = 170mm (6 $\frac{3}{4}$ "")
All Dimensions with Dust Cover Down

Weight

6.4 kg (14 lbs) net
7.5 kg (16 lbs. 8 oz) Packed

Packing Sequence

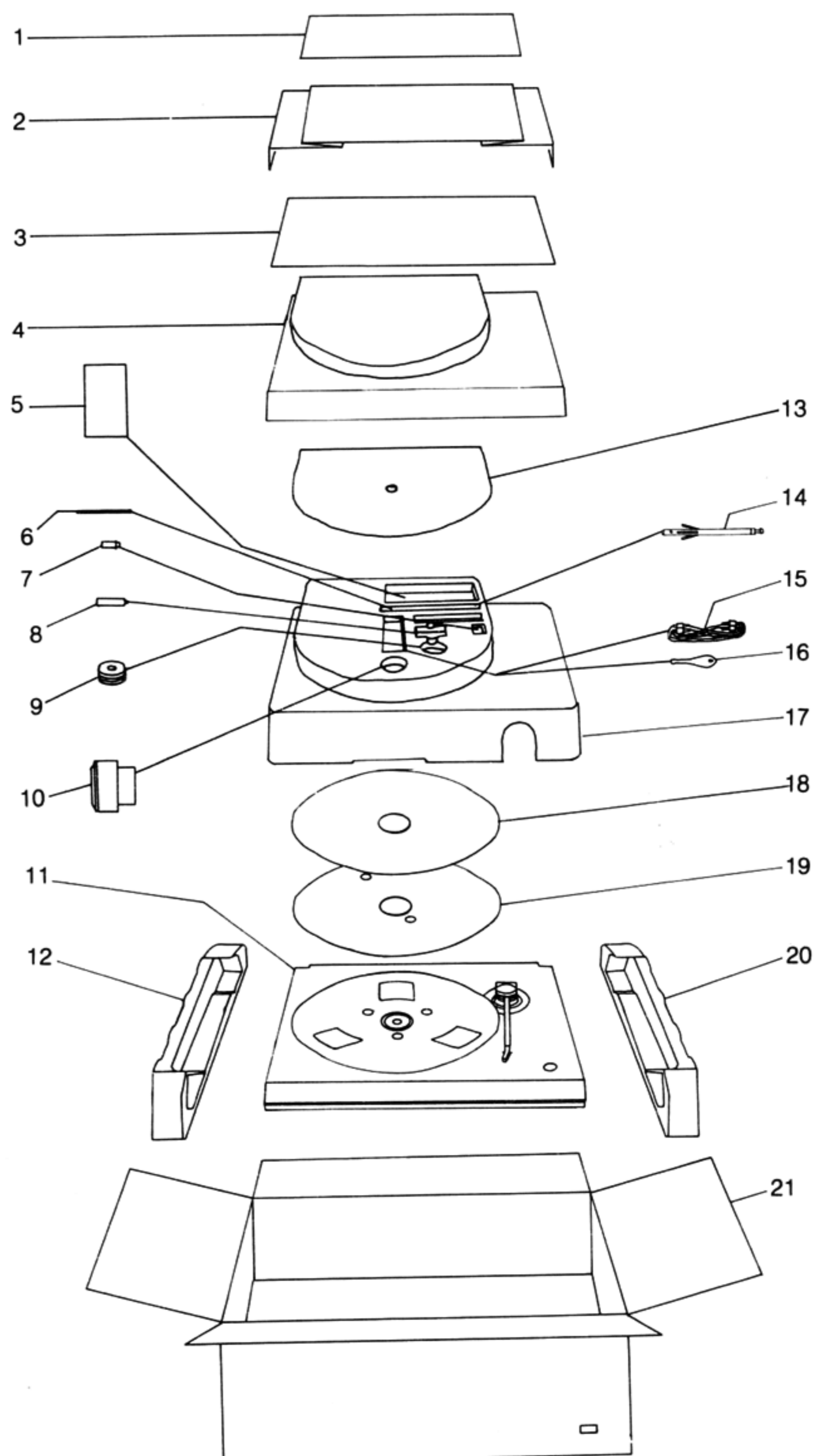

- | | |
|-----------------------------------|----------------------|
| 1. PACKING LIST | 10. COUNTERWEIGHT |
| 2. SPRING PAD | 11. TURNTABLE UNIT |
| 3. OWNER'S MANUAL & WARRANTY CARD | 12. FOAM CAP |
| 4. DUST COVER | 13. LAYER PAD |
| 5. REMOTE CONTROL TRANSMITTER | 14. UMBRELLA SPINDLE |
| 6. STYLUS BRUSH | 15. AUDIO LEADS |
| 7. ROTATING STUB SPINDLE | 16. SCREWDRIVER |
| 8. BATTERY | 17. FOAM PACK |
| 9. 45 RPM ADAPTORS | 18. TURNTABLE MAT |
| | 19. TURNTABLE PAD |
| | 20. FOAM CAP |
| | 21. CARTON |

Unpacking

Your turntable has been carefully packed to prevent damage from shipping and handling. Carefully remove it from its carton, and remove all foam packing, tape, tie-downs, etc. Check with the diagram to make sure you have removed all necessary parts before making final disposition of the packing material. We recommend you save the carton and all packing materials to afford your turntable maximum protection should you move or ship it in the future.

When moving your turntable from one room to another, the arm should be securely locked in its tonearm rest.

Placement & Installation

Install the dust cover before mounting the turntable in its location. Insert the protruding ends of the hinges of the dust cover fully into the hinge receptacles located at the rear of the turntable base. The dust cover may now be lowered or raised as desired. (See Figure 1).

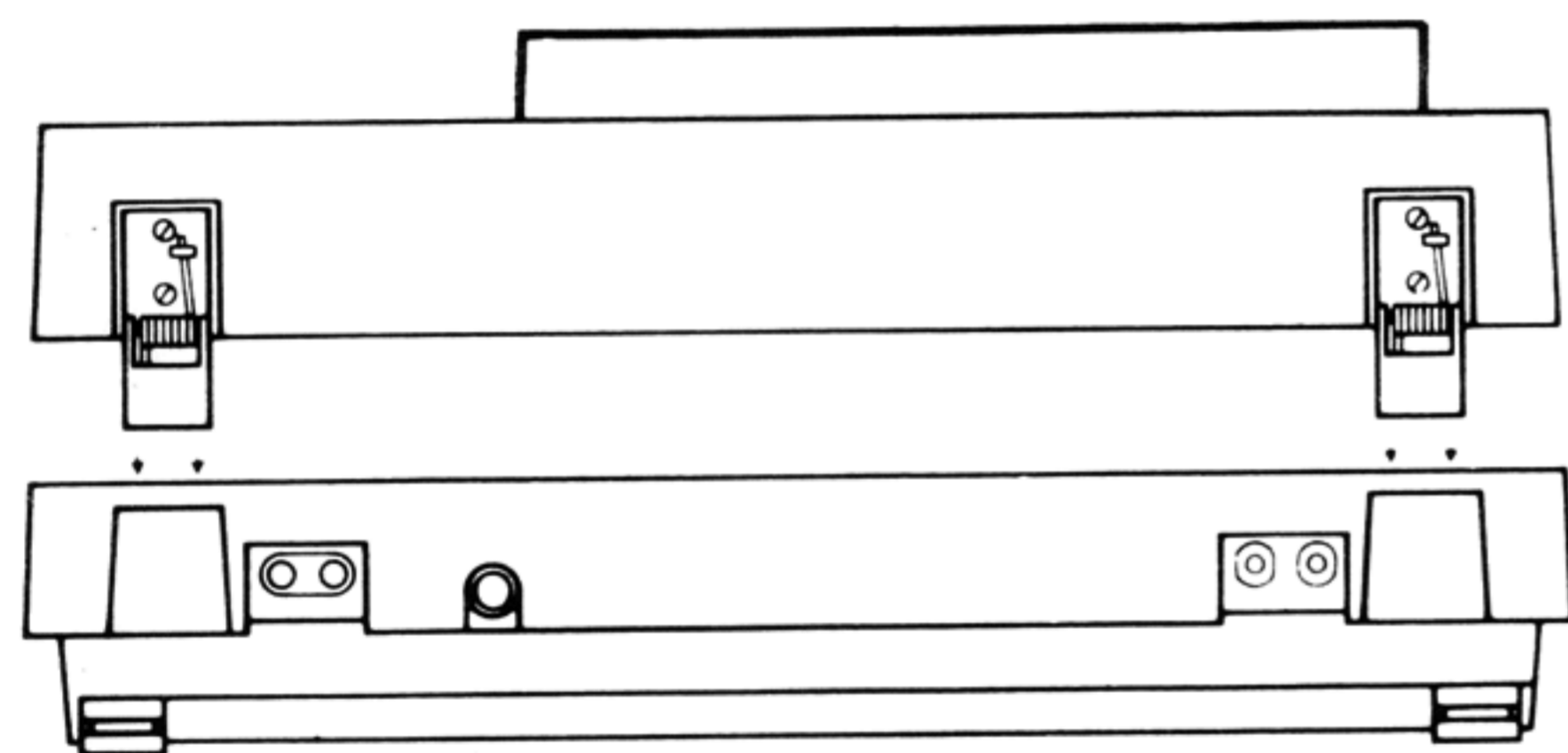

Figure 1

Installation Hints

Pick a stable location: Your turntable is well isolated against physical shock and vibration, but any turntable will perform best when mounted on a surface that does not shake in response to footsteps, slamming doors, or other vibrations. Shelves hung directly from the wall framing are usually best.

Stay away from speakers: Any turntable exposed directly to a loudspeaker's output can pick up vibrations from the speaker, adding undesired feedback to the sound you hear. To avoid this, do not mount your turntable directly on or directly in front of a speaker, or in any other position where the speaker's vibrations can affect it.

Avoid hum sources: Some amplifiers or other components can radiate hum fields which adjacent turntables can pick up. If you hear hum when listening to phono only, and you have checked all connections (see trouble-shooting hints), try moving the turntable a little farther from the amplifier or receiver. Sometimes, it is enough to move the turntable a few inches, or to interchange its position with the amplifier's. Poor grounding can also cause hum.

Your turntable can be installed on any level surface capable of holding its weight (a mere 6.4 kg, or 14 lbs.).

Assembly Turntable Assembly

1) The transit screws must now be turned clockwise (See Figure 2) to allow the turntable to float freely and to allow the platter to spin. (A) Using the transit screw key (supplied), turn the screw located through the opening in the turntable platter clockwise until the screw head is fully down onto the base board. (B) Repeat Step A, turning the second transit screw fully down onto the base board. The turntable should now float freely and the platter should be free to spin.

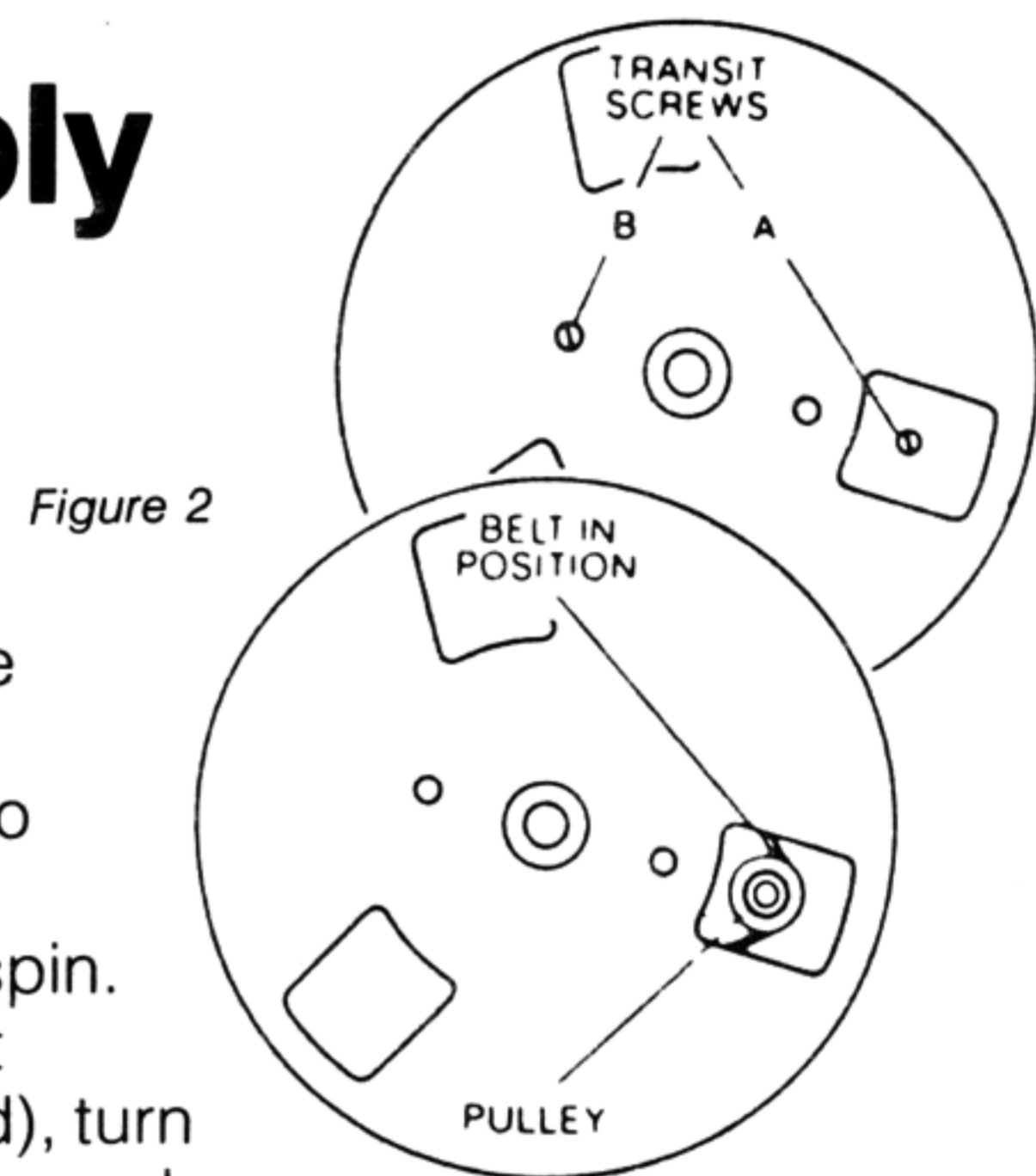

Figure 2

Figure 3

2) Check that the drive belt is in proper position (See Figure 3). Rotate the turntable platter until the drive pulley is clearly visible.

To reinstall the belt, lift the turntable platter straight up and check if the belt is seated on the inner rim of the underside of the platter. Replace the platter on the center bearing. Rotate the platter until one of the openings is over the motor pulley. Lift the belt away from the inner rim and place it over the motor pulley. Rotate the turntable platter several turns and check again through one of the openings that the belt is not twisted and properly seated over the pulley.

Be careful not to let grease or oil contact the belt.

3) Place the turntable mat on the turntable platter, seating it properly over the center trim disc.

Spindle Installation

1) Accuglide Umbrella Spindle. Insert the pointed end of the spindle into the hollow center bearing of the turntable and rotate it clockwise, applying downward pressure until it locks in position.

To remove the Accuglide Spindle, rotate it counterclockwise and lift straight upwards.

2) Rotating Manual Spindle. Insert the larger diameter of the manual spindle into the center of the turntable, seating it firmly. This spindle is designed to rotate with the turntable platter.

Tonearm Balance

1. Holding the counterweight assembly, with the black calibrated dial facing forward, slide the counterweight on the rear of the tonearm until a definite “click” is felt. The counterweight can now be rotated freely in either direction to balance the tonearm.

2. Rotate the anti-skate dial to “0”.

3. Remove the stylus guard.

4. Unlock the tonearm from the tonearm rest post.

5. Turn the power switch to “on”.

6. Press “cue” and note that the cueing platform has cued down.

7. Turn the power switch to “off”.

8. Holding the tonearm by the fingerlift, rotate the tonearm so that it is between the turntable platter and the tonearm rest post.

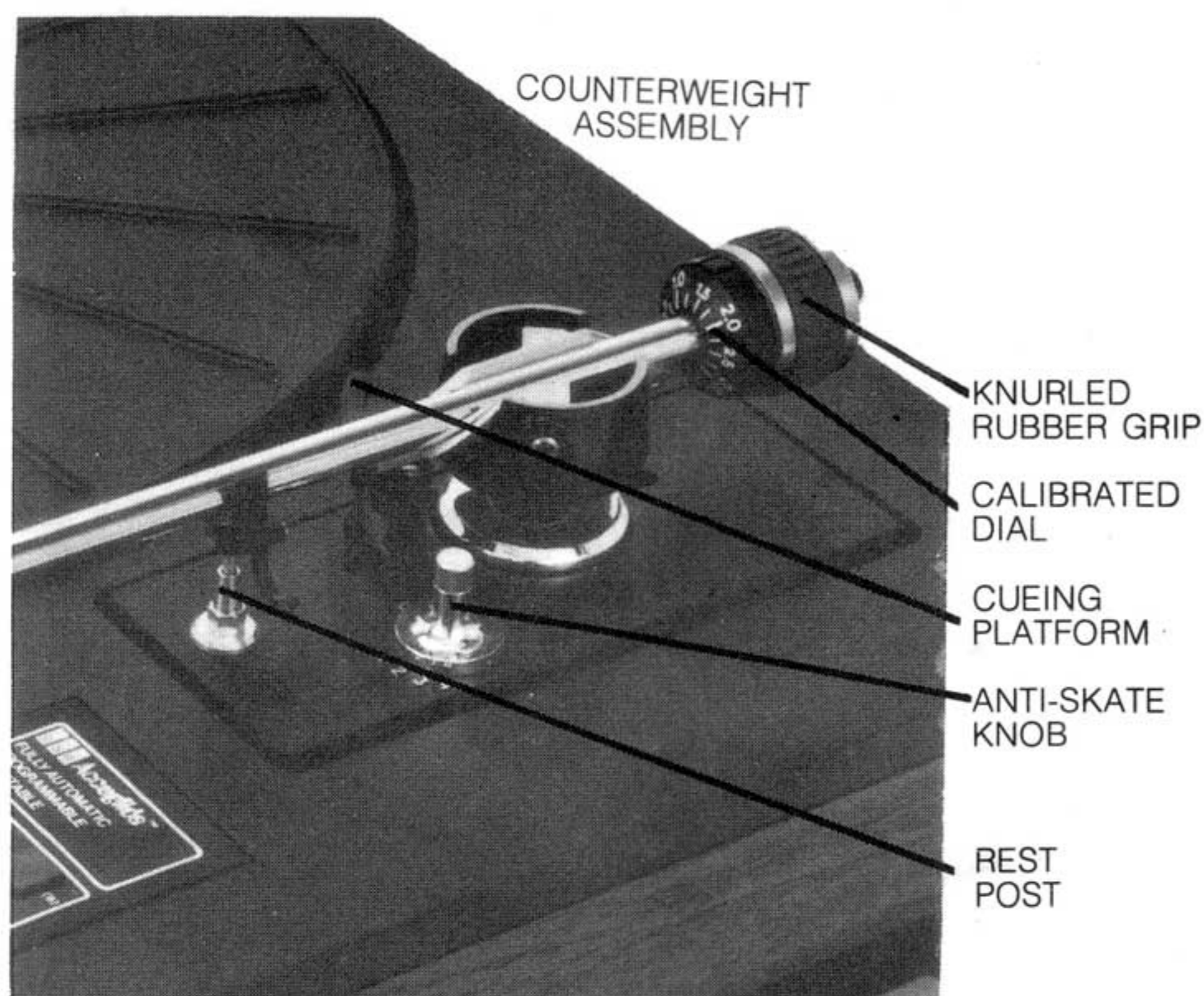

9. Rotate the counterweight until the tonearm is balanced (parallel to the turntable surface).

10. Return the tonearm to the rest post and lock it in position.

11. Holding the counterweight firmly by the rear knurled rubber grip, rotate the black calibrated dial until the “0” marking is directly above the tonearm tube (12:00 o'clock position).

12. Recheck the tonearm balance by unlocking the tonearm from its rest post to insure the position of the counterweight has not been disturbed.

13. Rotate the counterweight by the knurled rubber grip until the calibrated dial marking indicates 3 grams at the 12:00 o'clock position.

14. Rotate the anti-skate knob to 3 on the dial. (Your anti-skate and stylus pressure settings should be identical).

A Note on Tracking Force

The recommended range of tracking forces for the ADC QLM 32MKIII cartridge supplied with this turntable is from 2 grams to 4 grams, with 3 grams recommended under most circumstances.

If you hear distortion on loud or complex passages, you may increase the tracking force, using the minimum tracking that will eliminate the distortion. If distortion persists, try a fresh copy of the same recording — the original may have been damaged by a previous cartridge's mistracking, or by having been played at the wrong tracking force.

Connections

1) Plug the power cord into an AC outlet of appropriate voltage. (The voltage for which your turntable is manufactured is indicated on a label at the rear of the turntable base.) Should you move to an area where the voltage is different you will need an accessory or replacement transformer before you can use your turntable. No adjustment is required for differences in power line frequency. (50 Hz or 60 Hz.)

If available, the SWITCHED accessory AC outlet of your amplifier or receiver may be used for the turntable.

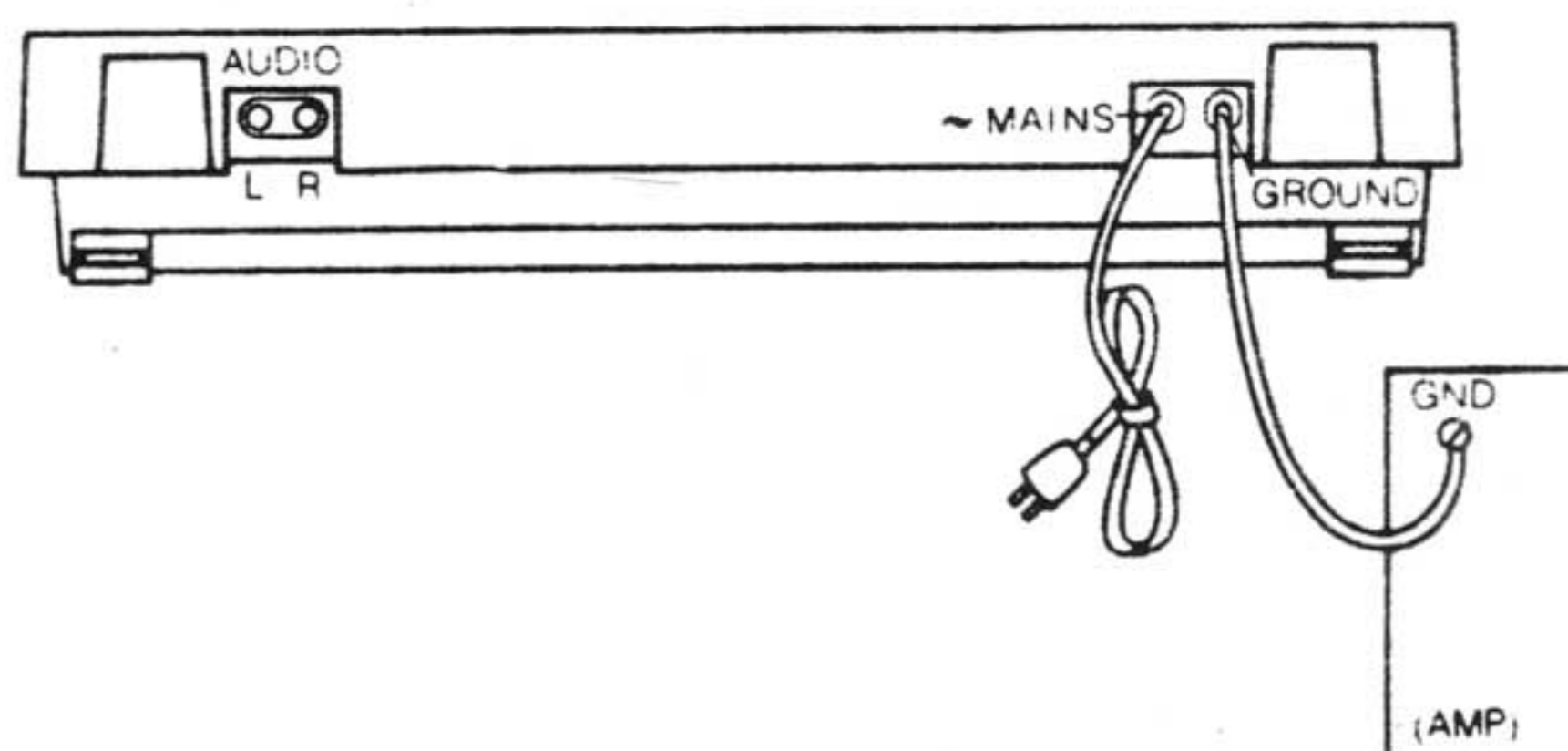

2) IMPORTANT For best results the green ground wire should be connected to the "Ground" terminal or screw in the amplifier, preamplifier or receiver to which your turntable will be connected. If no screw is marked "Ground" (earth), GND, or with the symbol "⏚", attach the wire to any screw that is attached directly to the amplifier or receiver's metal chassis. Do not attach to the speaker or antenna terminal screws.

If your system's ground connection is of the push-in type, you may cut off the spade lug on the end of the ground lead, strip about 1/4" (5mm) of insulation off the end of the wire, and insert into the ground terminal.

NOTE If these instructions are not followed, both erratic control functioning and hum may result. It is especially important that you connect the ground wire to your amplifying system's ground as described above.

3) Connect the audio cables between the output jacks at the rear of the turntable base and the magnetic "PHONO" input jacks of your amplifying system. Make sure you use the same color plug for the right channel of each end of cable assembly.

Battery Installation

Remote Control Transmitter

Slide open and remove the battery compartment cover located on the back of the remote control transmitter. Connect the 9 Volt Battery to the snap connector mating terminals of the remote transmitter. Insert the battery into the compartment and replace the cover.

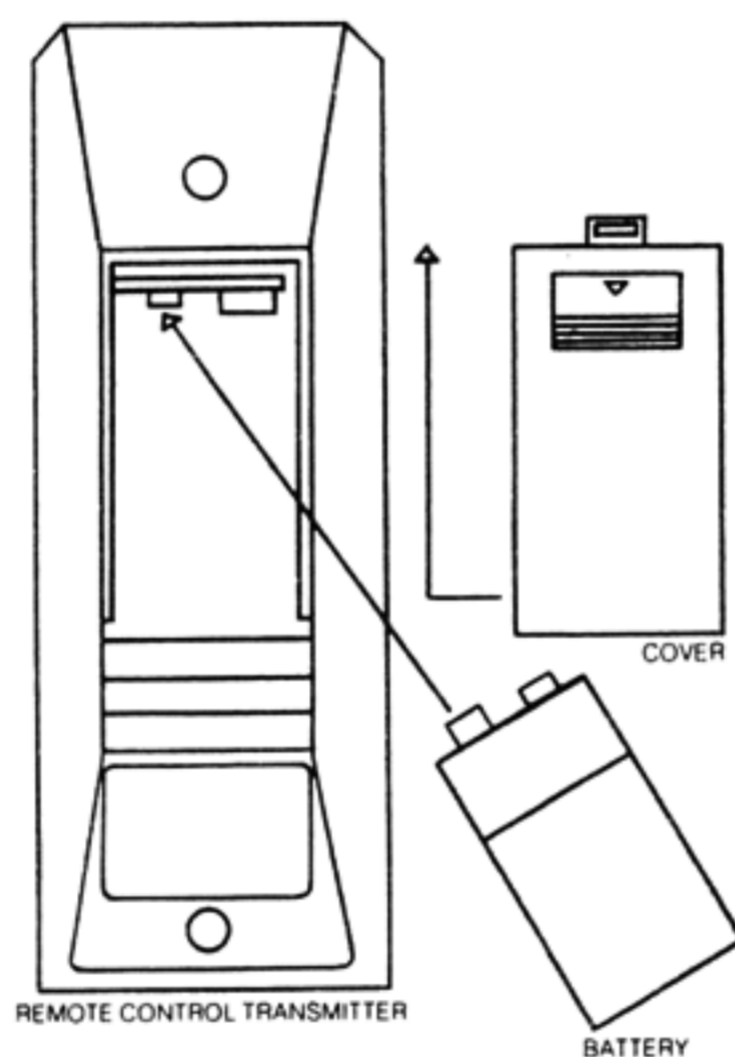

Description of Controls

The BSR XR-50 Fully Automatic Programmable Turntable has been designed to provide two (2) modes of operation.

The "PROGRAM" mode provides for each record (up to 6 records) to be programmed to play one or more times before proceeding to the next record. The computerized "Memory Bank" incorporated in this unit will accept a total of 27 commands. As commands are executed, more programs can be added.

The "AUTO MULTI-PLAY" mode is used for playing up to six (6) records, in sequence, conventionally.

Control Panel Functions

Actuate the keys by applying slight pressure with the finger. As the keys are actuated, the "Input Accepted" LED (Light Emitting Diode) will light up acknowledging acceptance of the command.

IMPORTANT A light touch is all that is necessary to actuate the control panel functions. Accidental multiple touches will be interpreted as multiple commands on the "Play", "Next Record", "Cue", "Reject/Stop" and "Auto Multi-Play" keys.

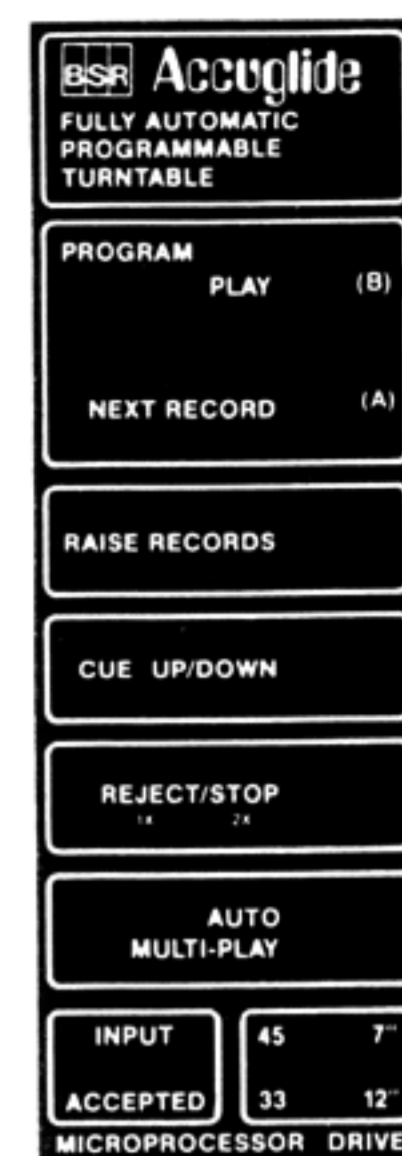

Program Mode

"Next Record" (A) Key

This command will call for the next record to be lowered to the turntable platter and must be followed by the command "PLAY" (B). Multiple touches of this key will be interpreted as that many records to be lowered to the turntable platter unless the "PLAY" (B) Key is actuated for each record to be played. Easy way to remember — Touch A first and then B as many times as you would like to hear that record.

"Play" (B) Key

Each record in the stack may be programmed to be played one or more times, therefore, in conjunction with the "NEXT RECORD" (A) Key, up to six (6) records may be programmed with a total memory of 27 commands.

FOR EXAMPLE: Three records are placed on the umbrella spindle . . . To play the first record three times, the second record once and the third record twice, the sequence of touching the keys would be:

- "Next Record" (A) — "Play" (B), "Play" (B), "Play" (B)
- "Next Record" (A) — "Play" (B)
- "Next Record" (A) — "Play" (B), "Play" (B)

This combination has used nine (9) spaces of memory.

REMEMBER: When using the "PROGRAM" mode always touch "Next Record" (A) Key first, then touch the "Play" (B) Key the desired number of times you wish to listen to that record. Continue programming the remainder of the records by

touching "Next Record" (A) followed by the "Play" (B) Key as many times as desired until all the records on the umbrella spindle have been programmed.

NOTE: *The LED "INPUT ACCEPTED" light will flicker whenever records are being raised or lowered. Should a command be entered while the LED is flickering, it will glow continuously until the key is released, acknowledging acceptance of the command.*

Raise Records Key

Touching this key will actuate the record transport system and raise all records to their original position on the umbrella spindle and also erase the complete memory.

Cue Key

Touching this key will raise or lower the tonearm. If the tonearm is on the record it will be raised and touched again, will be lowered to the record to continue playing.

Reject/Stop Key (1X)

When touched once (1X), the programmed memory is erased for that record and the tonearm will cue up and return to the arm-rest. If subsequent records have been programmed the turntable will continue to execute the remaining commands.

Reject/Stop (2X)

By actuating the key twice, the complete memory bank (for all records) is erased. The records being played will be interrupted, the tonearm will return to the arm rest and the turntable platter will stop rotating. Remember to reject that record only, touch the key once (1X). To erase the memory bank completely for all records on the turntable touch the Reject/Stop Key twice (2X).

Auto Multi-Play Mode

"Auto Multi-Play" Key

Touch this key once for each record placed on the umbrella spindle. The Accuglide Record Transport System will lower and play each record on the umbrella spindle. For example; if three (3) records are placed on the spindle the key must be touched three (3) times to play all three records. Touching this key more times than the number of records on the spindle will result in the last record being played until all the commands are executed.

Operating Instructions

IMPORTANT:

1. Whenever the unit is initially turned "ON", wait 5 to 8 seconds for the unit to prepare itself to receive commands. When the unit is ready, two "clicks" will be heard, then start entering the program.
2. Do not intermix 7 inch and 12 inch records. Do not attempt to use an automatic 45 adaptor.
3. *Some 7 Inch, 45 RPM records have the small center hole for use with the standard spindle: however, should your records have a large center hole, it will be necessary to install a small hole adaptor in the large center hole for use with this turntable.*

Program Operation

"NEXT RECORD" (A) and "PLAY" (B) KEY FUNCTION Programmed playing of up to six (6) records

1. Turn the unit "ON" and wait until two (2) "clicks" are heard.
2. Place the records on the umbrella spindle
3. Place the Size/Speed switch in the proper position corresponding to the record size to be played.
4. Touch the "NEXT RECORD" (A) key.
5. Touch the "Play" (B) key as many times you wish to repeat the record.
6. Touch the "NEXT RECORD" (A) key to program the next record and again touch the "PLAY" (B) key as many times you wish to repeat the second record.
7. Continue the programming by touching the "NEXT RECORD" (A) key once, followed by "PLAY" (B) as many times as you desire to listen to that record or until all records have been programmed.

THE MEMORY BANK IS CAPABLE OF STORING A TOTAL OF 27 OF COMBINED "NEXT RECORD" (A) AND "PLAY" (B) COMMANDS.

8. Should you desire to skip one or more records in the stack, during programming, touch the "NEXT RECORD" (A) key as many times, then continue to program the remainder of the records.

9. When all records have been played, touch the "RAISE RECORDS" key to raise all the records to the top of the umbrella spindle for removal of the records.

NOTE: To reject the record being played, touch the Reject/Stop key once. The turntable will execute the remainder of the commands, if any.

To STOP the turntable, touch the Reject/Stop key twice.

TO TURN OFF THE TURNTABLE COMPLETELY, THE POWER SWITCH MUST BE RETURNED TO THE "OFF" POSITION.

Auto Multi-Play Operation

"Auto Multi-Play" Key Function
(To play up to six (6) records in sequence, conventionally)

1. Turn unit "ON" and wait until two (2) "clicks" are heard.
2. Place the records (up to 6) on the umbrella spindle.
3. Place the Size/Speed switch in the proper position corresponding to the record size to be played.
4. Touch the "Auto Multi-Play" key as many times as the number of records placed on the umbrella spindle. The first record will automatically be lowered and played. When the record has finished playing, the tonearm will return to the armrest and the ACCUGLIDE TRANSPORT SYSTEM will transport the second record to the turntable and play. This sequence will continue until all records have been played.

NOTE: To reject the record being played, touch the Reject/Stop key once. The turntable will execute the remainder of the commands, if any.

To STOP the turntable, touch the Reject/Stop key twice.

TO TURN OFF THE TURNTABLE COMPLETELY, THE POWER SWITCH MUST BE RETURNED TO THE "OFF" POSITION.

Automatic Single Play

1. Place a record on the umbrella spindle.
2. Set the Size/Speed switch to the record size to be played.
3. Touch the "NEXT RECORD" (A) key.
4. Touch the "PLAY" (B) key:
 - a. The AUTOGLIDE RECORD TRANSPORT will lower the record to the turntable platter, play

the record and the tonearm will return to the armrest.

- b. Touch "PLAY" (B) key as many times (up to 25 more times) for repeat play of the record.

Manual Single Play (Method 1)

1. Remove the umbrella spindle by rotating it counterclockwise and lift it out.
2. Install the manual stub spindle into the platter center hole.
3. Place a record on the turntable platter.
4. Unlock the tonearm, if locked, and locate it over the starting groove or selection on the record.
5. Touch the "CUE" key — The turntable platter will rotate and the tonearm will lower to the record and play.
6. When the record has completed playing, the tonearm will return to the armrest and the turntable will stop rotating.

NOTE: The "REPEAT" function on the Remote Control Transmitter is not operative when using this method for Manual Single Play.

TO TURN OFF THE TURNTABLE COMPLETELY, THE POWER SWITCH MUST BE RETURNED TO THE "OFF" POSITION.

IMPORTANT: DO NOT TOUCH THE "RAISE RECORDS", "NEXT RECORD" OR "AUTO MULTI-PLAY" KEYS WHEN USING THE MANUAL STUB SPINDLE.

Playing 12 Inch, 45 RPM Records

Relatively recently, 12 Inch, 45 RPM Records were introduced and are now readily available.

These can be played "MANUALLY" by setting the Size/Speed Selector at 12 Inch, 33 $\frac{1}{3}$ RPM and after Cueing the tonearm down to play, move the Size/Speed selector to the 7 Inch, 45 RPM position for playing.

Manual Single Play (Method 2)

1. Remove the umbrella spindle by rotating it counterclockwise and lift it out.
2. Install the manual stub spindle into the platter center hole.

3. Place a record on the turntable platter.
4. Unlock the tonearm, if locked.
5. Touch the "PLAY" (B) key once.
6. When the record has completed playing, the tonearm will return to the armrest and the turntable will stop rotating.

NOTE: To "REPEAT" the record, touch the "PLAY" (B) key as many times as you desire to hear the record.

If the "REPEAT" command is entered from the Remote Control Transmitter, the command can only be entered one time and only while the record is being played.

TO TURN OFF THE TURNTABLE COMPLETELY, THE POWER SWITCH MUST BE RETURNED TO THE "OFF" POSITION

IMPORTANT: DO NOT TOUCH THE "RAISE RECORDS", "NEXT RECORD" OR "AUTO MULTI-PLAY" KEYS WHEN USING THE MANUAL STUB SPINDLE.

Operating the Remote Control Transmitter

Remote Control (Infra-Red) Transmitter

The remote control transmitter operates on the infra-red principle. Simply aim it towards the turntable and press the function key desired.

Battery Check

Each time a key is pressed the small red light will flicker. This is an indication that the transmitter is functioning.

Failure to light is an indication that the battery is weak and should be

replaced. The small red light "INPUT ACCEPTED", on the keyboard of the turntable will acknowledge all commands as the keys are pressed on the remote control unit.

Volume Up/Down

The Remote Control Transmitter incorporates two (2) keys marked Volume "UP" and "DOWN", respectively. To operate, depress and hold the appropriate key. The volume will increase or decrease accordingly and when the desired listening level is achieved, release the key.



Set-Up Procedure

When the Accuglide XR-50 turntable is initially turned "ON", the electronics controlling the "Remote Volume Feature" is at maximum output, therefore, the listening level cannot be increased by depressing the Volume "UP" key. In order to achieve a range of adjustment that will provide you with an increase in listening level, adjust the volume control setting of your sound system somewhat higher than normal listening level. Then lower the level to your listening preference by depressing the Volume "DOWN" key.

This simple adjustment now affords you the convenience of raising or lowering the listening level remotely from the comfort of your easy chair.

NOTE: Remember to lower the volume control of your sound system before switching to the other modes of operation, e.g. FM, Tape, etc.

When recording from your turntable, adjust the volume from your remote control transmitter to maximum output, thereby insuring maximum signal strength to your tape recorder.

The Accuglide XR-50 turntable will automatically reset to its maximum output setting upon "Turn-On", irrespective of the level set when the unit was turned "OFF".

Program Function

"Next" (A) key calls for a record to be lowered to the turntable platter. Actuating the key more than once will be interpreted as multiple commands.

"Play" (B) key commands the turntable to play that record as many times as the key is pressed.

Key functions "Play" (B), "Next" (A), "Cue", "Raise" and "Reject" on the Remote Control Transmitter are identical to the Control Panel functions on the main keyboard of the turntable.

Cue

Pressing the "Cue" key while the record is playing will cause the tonearm to be raised and hold above the record. Pressing the "Cue" key again will lower the tonearm to the record and continue playing the record. This function serves as a "Pause Control" and may be actuated any time during the playing of a record.

Raise

Pressing this key will erase the complete memory, return the tone-arm to the arm rest and raise all the records to the top of the umbrella spindle.

Repeat

While the record is playing, by pressing the "Repeat" key that record will be played again before proceeding to the next programmed command.

Reject

Press this key once to reject the record being played. Pressing this key twice, the complete memory for all records is erased.

Common-Sense Trouble-Shooting

Most problems with most devices, the BSR XR-50 included, are due to either loss of power (the plug accidentally pulled out of the socket, or plugged into a socket to which power has been shut off) or operating with the wrong control settings. So before trying any of the specific hints below, re-check:

POWER Is the plug in, the outlet live and the switch on?

CONNECTIONS Are ground and the audio cables connected to the hi-fi system properly, is the system switched to its PHONO input and is its Tape Monitor switch in SOURCE position?

CONTROLS Is POWER on? Then touch "REJECT" twice and program the Turntable again by touching "AUTO MULTI-PLAY" or "NEXT RECORD" followed by "PLAY".

If after the above, you still have a problem, try the following:

Problems Causes & Cures

Hum:

If hum only occurs when your amplifier is set to the PHONO input to which the Turntable is connected, then check:

THE GROUND WIRE Is it connected between turntable and amplifier?

THE AUDIO CABLES Are they pushed fully into their jacks at both the amplifier and turntable ends? Are their shields broken? (If hum appears and disappears as you wiggle the cable, this is probably the cause; replace such cables.)

ACOUSTIC FEEDBACK If the hum only occurs when the arm is actually on the record, or disappears when you shut your speakers off and listen through headphones, this may be the case. If so, relocate the turntable or the nearest speaker.

OTHER CAUSES Look behind the cartridge to see that all its connections are intact. If all else fails, try disconnecting the green ground wire from the amplifier. Hum will probably increase, but may decrease if there is a ground loop in your system.

Remote Volume Control Does Not Operate

If all of the control buttons on your remote transmitter operate properly and the "Up" and "Down" volume buttons do not operate, try a fresh battery.

Remote Control Does Not Operate:

If the light goes on for keyboard commands, but not for remote commands, be sure you are aiming at the front of the turntable, check the battery connections or replace the 9-volt battery in the transmitter.

NOTE: *The remote transmitter has been designed to operate at distances up to 30 feet.*

Dust Cover Charged With Static Electricity:

To remove the static charge, simply wipe the entire dust cover lightly with a damp cloth. If the problem persists, remove the dust cover from the unit and wash it in a mild solution of ordinary dishwasher detergent and water, e.g., Joy.

Stylus Installation

The Stylus Assembly for this ADC Stereo Cartridge is designed to lock into proper position when slid onto cartridge body in the manner illustrated.

It is further suggested that careful installation and removal of the Stylus Assembly be accomplished while protected by the Stylus Guard.

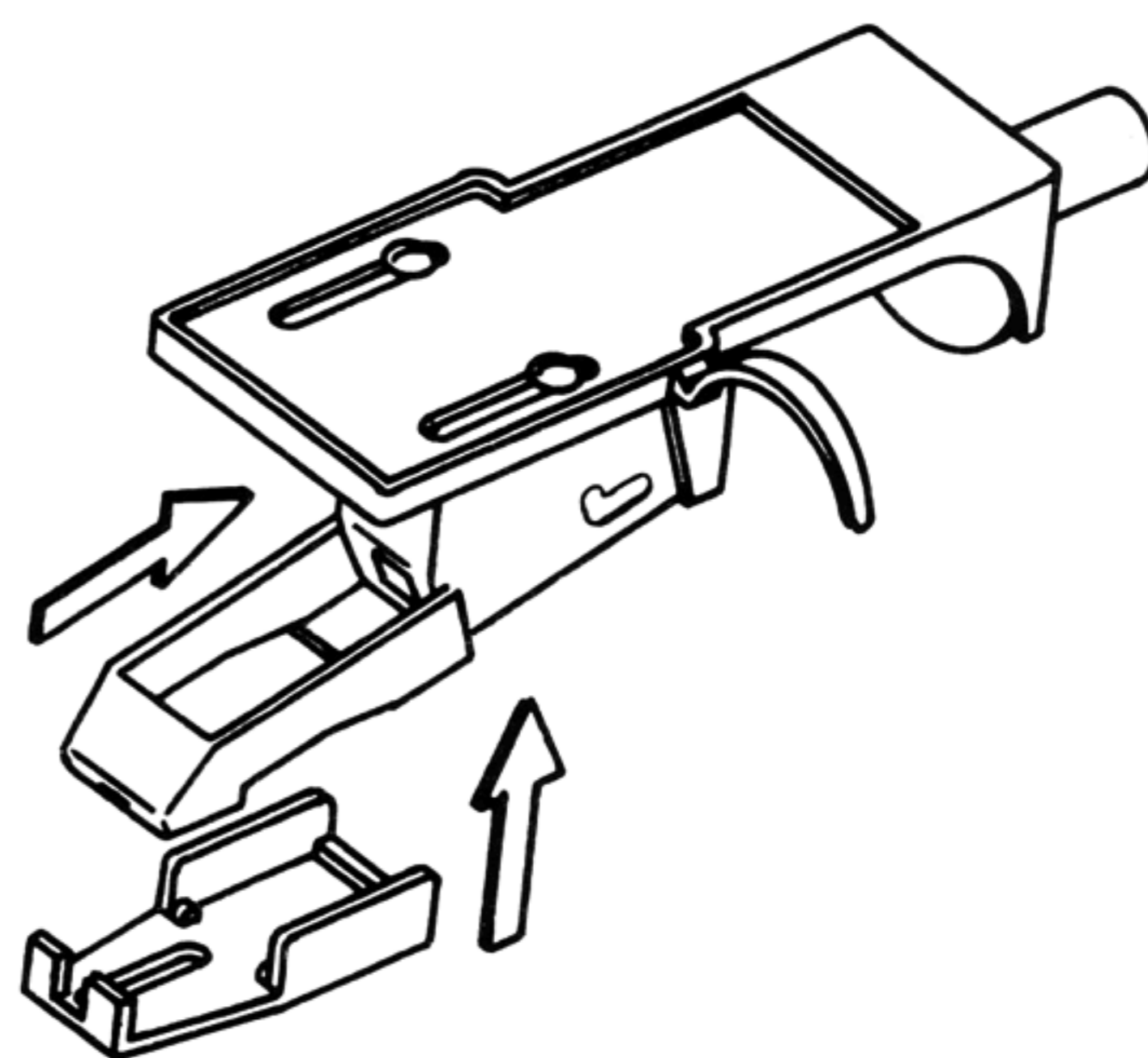

ADC Replacement Styli

ADC cartridges are quality constructed to last for the life of your record player under normal playing conditions.

The only part that may need replacement is the stylus which comes in contact with the record and in time will show signs of wear. This will affect the sound quality and could damage the record grooves and should be replaced promptly.

Stylus is replaceable with the ADC RSQ32.

All specifications and features subject to change without notice.

Repacking

When moving or shipping your turntable, it is **IMPORTANT** that you do the following to prevent damage:

- Lock the arm in its rest, and tape or tie it in place.
- Install the plastic stylus guard back on the cartridge.
- Remove the mat.
- Remove the counterweight assembly.
- Turn the transit screws counterclockwise until they are tight and the turntable no longer floats freely.
- Remove the 9 volt battery from the remote transmitter.
- If you need to return your turntable for service or any other reason, be sure to include *all parts and accessories*, including both the remote control transmitter, and battery.

WARNING TO PREVENT FIRE OR SHOCK HAZARD, DO NOT EXPOSE THIS APPLIANCE TO RAIN OR MOISTURE.

Important Safeguards

Please read all the instructions in this section. When using electronic equipment, basic safety precautions should always be followed, including the following:

1. Do not connect the power plug to the AC outlet until the turntable has been completely assembled, interconnections to your sound system have been completed and the ground (green wire) of the turntable has been permanently affixed to the chassis ground of the amplifier.
2. To protect against electrical hazards of fire or electrical shock, do not expose this turntable to rain or moisture. This includes a wet basement or near a swimming pool.

3. Mount the turntable either on a wooden shelf hung from the wall framing, on top of a table or furniture.
4. As with other quality sound equipment, adequate ventilation will extend the trouble-free life of your turntable. Do not install the unit in an overly confined area along with other heat generating equipment. Avoid built-in cabinet or book case installations unless provided with adequate ventilation and/or ports that cannot be obstructed by adjacent furniture, rugs or other factors that can impede the flow of air through the ventilation openings.
5. Check the power requirements of the turntable as indicated by the label on the rear panel of the unit to ensure it conforms to the available power of the wall outlet.
6. Route the power cord so that it cannot be walked on, pinched by items placed on or against it or damaged by a vacuum cleaner.
7. Clean the turntable using a dust cloth. If the dust cover becomes charged with static electricity, remove it from the turntable and wipe it with a slightly damp cloth or wash it in a mild solution of ordinary dish-water detergent.
8. Unplug the unit from the wall outlet if it will be unused for a long period of time.
9. Do not place objects on or near the turntable that may accidentally fall into openings. Liquids should not be placed on or near the unit to prevent spilling into the enclosure. Disconnect the power plug from the wall outlet before attempting to remove objects or wipe spilled liquids.
10. Servicing of your unit should be referred to qualified service personnel if:
 - a. The power cord or plug has been damaged.
 - b. Objects have fallen, or liquid has been spilled, into the unit.
 - c. The unit has been exposed to rain or moisture.
 - d. The unit does not appear to be operating normally, or there is a marked change in performance.
 - e. The unit has been dropped or its enclosure damaged.
 - f. Servicing of the unit is beyond that described in the operating instructions.



BSR Consumer Products Group
Route 303, Blauvelt, New York 10913