



CONCERTO

OPERATING INSTRUCTIONS

FOR

MODEL CSD

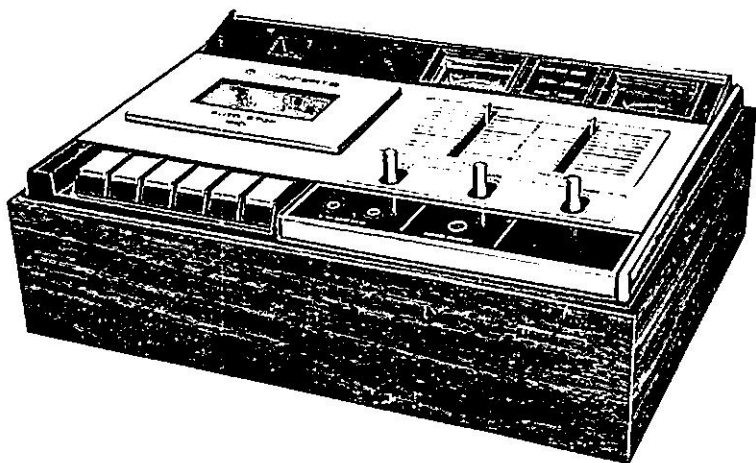

STEREO CASSETTE DECK

CONTENTS

Before you operate the unit	1
About cassettes	1
Protection of recorded tapes against accidental erasure	1
Function and name of each part	3
How to connect with a stereo system	4
Recording	4
Tape playback	4
Caution	4
How to connect with stereo amplifier	5
How to connect with other sound source for recording	5
Recording	6
Good recording – Good sound	
Check the following points	8
Auto stop	8
Recording on the other side of the tape	8
Rewind	8
Monitoring recorded sound	8
Pause button	9
Monaural recording	9
Playback	9
Playback the other side of the tape	10
Stereo headphones	10
Erasing recorded tape	10
Maintenance	11
Cleaning the heads	11
Head demagnetization	12
How to change the voltage	12
Specifications	13
Schematic diagram	14

BEFORE YOU OPERATE THE UNIT

- * Never place this set on other hi-fi equipment as the heat could cause damage. Equally, if the set is placed in a cold area or an area subject to vibration damage could be caused.
- * Please keep the heads clean. Low sound, poor recording.....these are in most cases due to dirty recording heads. For details on cleaning the heads, please refer to the "Maintenance" column.
- * In the following circumstances, the "RECORD" button cannot be depressed (but this is not a defect, and so do not force the button).
 1. Where a cassette is not installed correctly in the cassette compartment.
 2. Where the cassette installed has the erase protection tabs removed.

ABOUT CASSETTES

Cassettes have a side A and a side B, on which you can record and play back. For record/playback on side A, insert the cassette with side A upper most and the tape facing you. For side B the same technique applies.

During record/playback, the tape runs from left to right, so when you record/playback on either side ensure to insert the tape with it wound on the left side of the cassette.

PROTECTION OF RECORDED TAPES AGAINST ACCIDENTAL ERASURE

Pre-recorded cassettes are protected against accidental erasure with an interlock system on the recorder. You can obtain the same protection for the tapes you have recorded yourself. As shown in the sketch, there are two tabs on the back edge of the cassette which can be pulled out with a small screwdriver or nail file. When these are removed, the cassette cannot be re-recorded or erased accidentally. Since each tab protects only one direction, both must be removed to protect an entire cassette. Cassettes with tabs removed may be erased or re-recorded if tape is placed over the tab holes. (See Fig. 1)

* Handling and Maintenance of Cassettes

Do not place cassette on or near, heaters, direct sunlight, high humidity or near machines producing magnetic fields (e.g. TV's, amplifiers, speakers).

- ** Do not touch the tape with your finger. This could cause damage to the tape.
- ** Before inserting the cassette into your set, ensure that the tape is not loose within the cassette as it could accidentally become caught in the mechanism. Tape can be wound tight by using an hexagonal pencil (See Fig. 2)

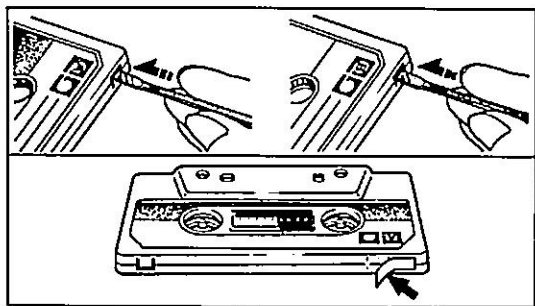

Fig. 1

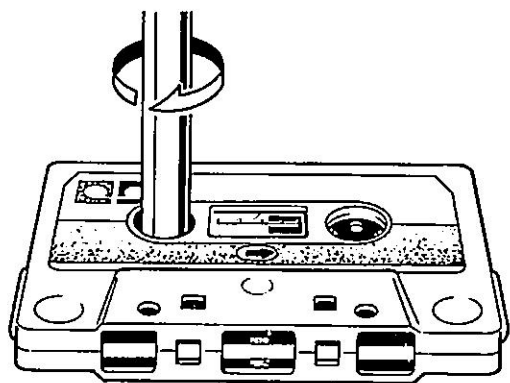
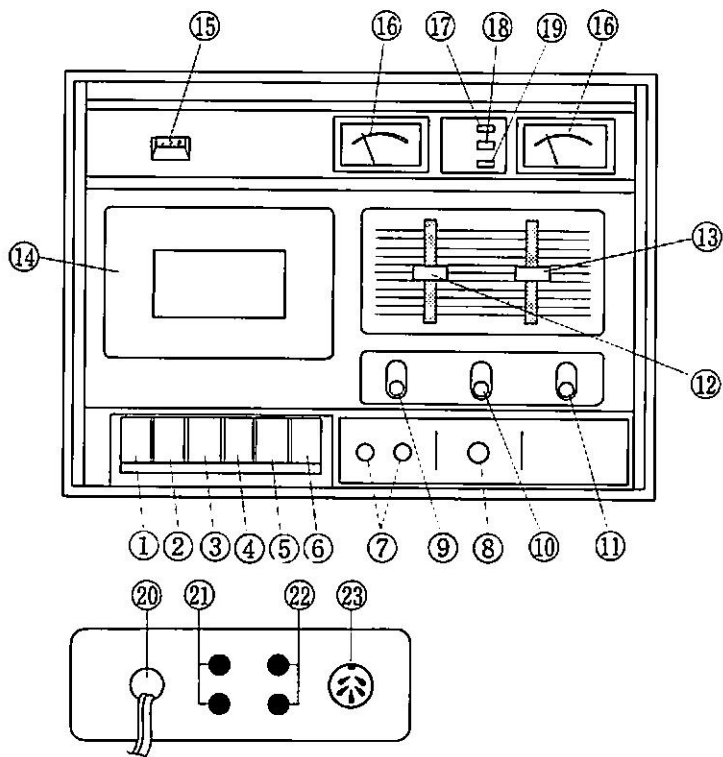

Fig. 2

FUNCTION AND NAME OF EACH PART



- | | |
|-----------------------------------|---------------------------------|
| ① Record Button | ⑬ Right Level Control |
| ② Rewind Button | ⑭ Cassette Compartment Lid |
| ③ Fast Forward Button | ⑮ Tape Counter |
| ④ Play Button | ⑯ Level Meters (Right & Left) |
| ⑤ Stop & Eject Button | ⑰ Noise Cut Light (Blue) |
| ⑥ Pause Button | ⑱ Tape Selection Light (Orange) |
| ⑦ Microphone Jacks (left & right) | ⑲ REC Light (Red) |
| ⑧ Headphone Jack | ⑳ AC Line Cord |
| ⑨ Noise Cut Switch | ㉑ AUX Output Jacks |
| ⑩ Tape Selection Switch | ㉒ AUX Input Jacks |
| ⑪ Power On-Off Switch | ㉓ Din Jacks (Record/Playback) |
| ⑫ Left Level Control | |

HOW TO CONNECT WITH A STEREO SYSTEM

RECORDING

Connect the "AUX INPUT" jacks on the recorder to "REC OUT" jacks on a stereo amplifier or receiver.

TAPE PLAYBACK

Connect the "AUX OUT" jacks of the recorder to "TAPE" or "AUX INPUT" of a stereo receiver.

CAUTION

1. If a connection between the recorder and stereo amplifier/receiver has been made as follows:
Recorder "AUX OUT" to amplifier "AUX IN"
Recorder "AUX IN" to amplifier "REC OUT"
and if you leave by mistake the Selector Switch of the amplifier receiver in "AUX IN" position and you operate the recorder in the record mode, it is possible that an abnormal sound will be reproduced from the speaker. This is produced by a feedback phenomenon that the output signal comes from "REC OUT" connection of the amplifier then goes through the recorder and returning to the "AUX IN" of the amplifier.
When you switch the selector switch of the amplifier/receiver, first be sure to select the position which you wish to record, then operate the recorder.
2. DIN TO DIN CONNECTION
If your amplifier/receiver has DIN plug connections, simply connect both DIN plugs to appropriate jacks, then both recording and playback processes can be made.
When you use DIN plug, be sure not to connect "AUX IN" jacks and "AUX OUT" jacks of the recorder at the same time.
** If you want the best possible recording, connection with pin plug cords is recommended rather than connection with DIN cord.
3. When both "AUX IN" of the recorder and "MIC" jacks are connected to the sound source, recording through "MIC" jacks has preference, and no recording is made through "AUX IN".
For recording through "AUX IN", please disconnect microphones.

HOW TO CONNECT WITH STEREO AMPLIFIER

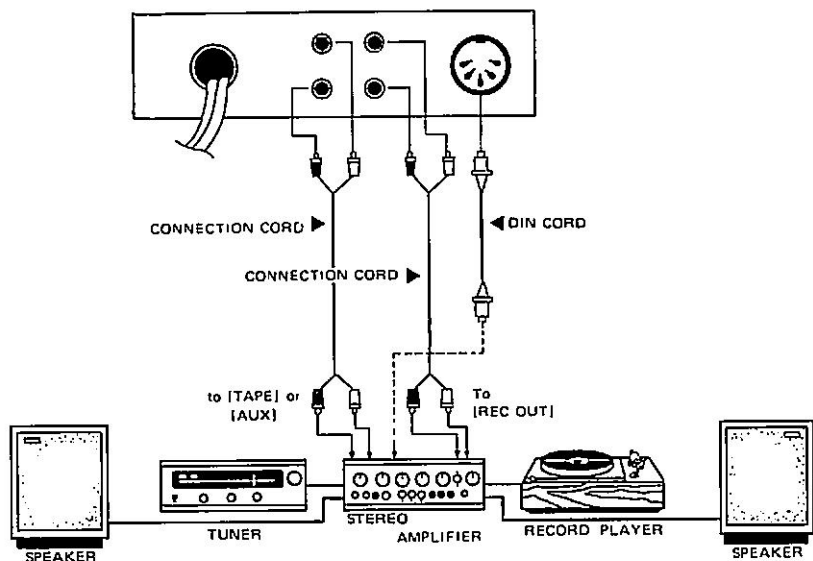

HOW TO CONNECT WITH OTHER SOUND SOURCE FOR RECORDING

Depending on sound source (microphone, tape recorder, etc.), the connection should be made to either MICROPHONE JACKS or AUX IN JACKS.

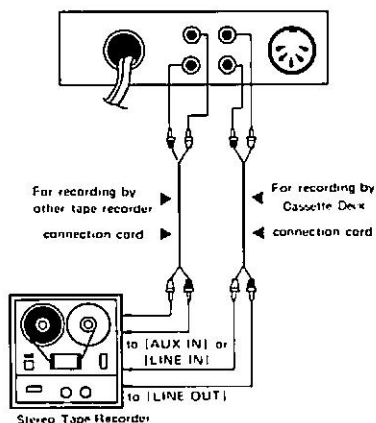

RECORDING

Please refer to the section on "HOW TO CONNECT WITH STEREO AMPLIFIER" and "HOW TO CONNECT WITH OTHER SOUND SOURCES FOR RECORDING".

1. Turn on the power switch — the illumination of the Level Meter shows that the power is on.
2. Press the STOP/EJECT button and the cassette cover will open.
3. Insert the cassette. When you make a subsequent recording on the tape, the previous recording will be automatically erased.
4. Close the cassette cover.
5. Decide the position of the Tape Selector. When you use chrome tape select "CHROME" and for normal tape select "NORMAL".
6. Press the RECORD button, then the recording indicator will illuminate.
7. Adjust the recording level with right and left volume controls, watching the Level Meters. When the pointers of Level Meters lie between red and blue, or slightly lower than this, then there are the best recording levels.
8. Press the re-set button on the Tape Counter ... the tape counter then will show "000".
9. Press the RECORD AND PLAY buttons simultaneously. Now the tape will start to record.

RECORDING

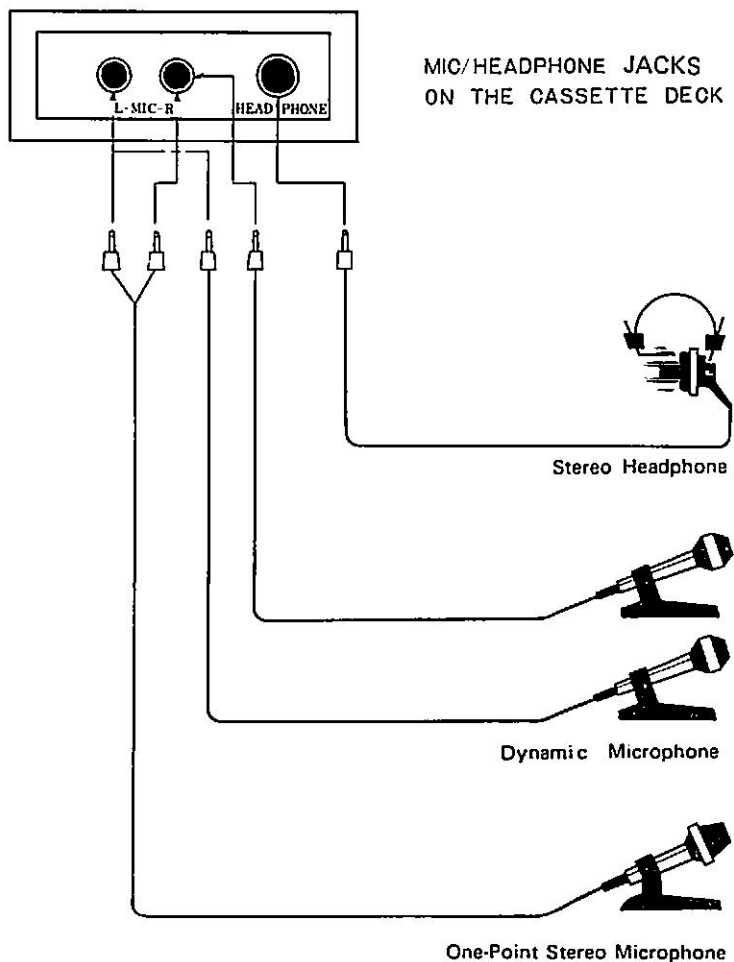

****GOOD RECORDING – GOOD SOUND CHECK THE FOLLOWING POINTS**

- * Have you read this instruction manual thoroughly?
- * Is the tape head clean?
- * Have you made the correct connections?
- * Is the Tape Selector in the correct position (CHROME OR NORMAL)?
- * Are the Recording Levels correct? Once these levels are fixed do not alter.

AUTO STOP

This recorder has an Auto Stop mechanism. When the tape comes to the end during the operation of RECORD, REWIND, FAST FORWARD and PLAY, the tape is automatically stopped.

However, if the power switch is still at the on position, and you do not want to use the recorder further, please turn off the POWER SWITCH. The Auto Stop system operates about 2 seconds after the tape comes to an end.

RECORDING ON THE OTHER SIDE OF THE TAPE

1. Press the Cassette Eject button and take out the tape. Insert the cassette with the other side up.
2. Follow the instructions as per "RECORD".

REWIND

Press the REWIND button for rewinding the tape.

MONITORING RECORDED SOUND

Before recording, connect the plug of the Stereo Headphones to the Headphone jack in the recorder. In this way you can listen to sounds while you record them. So that you can adjust the recording levels by the balance of the right and left volume, it is advisable to watch the Level Meters during monitoring. The meters will indicate the best levels for your recording.

PAUSE BUTTON

During recording, if you wish to miss out part of the recording material, press the PAUSE button. This makes the tape stop at once, and by pressing the button again you can make it return, and recording will continue. In this way you can only tape the sounds you really want to record. The PAUSE button also works for Playback of the tape.

If the recorder remains in the stop position for a long time be sure to press the STOP button. The PAUSE button should only be used for temporary breaks in the sound.

MONAURAL RECORDING

Connect the monaural sound source to either Right or Left of the "AUX IN" jacks on the recorder, or connect the microphone to Right or Left microphone jack. For monaural recording, it is better to use the Right channel in view of the track pattern of the cassette tape.

PLAYBACK

For connections, please refer to "HOW TO CONNECT WITH STEREO AMPLIFIER".

1. Turn on the power switch and the Level Meters will illuminate.
2. Press the Cassette Eject button and the cassette cover opens.
3. Install the recorded cassette tape.
4. Close the cassette cover.
5. Press the PLAY button. Then the tape counter and Level Meters will commence to operate.
6. Adjust the volume control so that the pointers on the Level Meters do not come up to the red scale. Then adjust the Volume of your stereo amplifier/receiver until you find the best listening level.
** Tape selector switch does not work for "PLAYBACK".
7. Noise Filter
During playback, if you want to eliminate "hiss" noise or soften the high tone, turn on the noise cut.

PLAYBACK THE OTHER SIDE OF THE TAPE

1. Press the Cassette Eject button. Take out the cassette tape and reverse it before re-inserting it.
2. Repeat the operation of 5.6 under PLAYBACK.

STEREO HEADPHONES

For private listening, connect the STEREO HEADPHONE to the Headphone jack.

ERASING RECORDED TAPE

When you record on used tape, the previous recording will be automatically erased.

However, if you want to erase a previous recording without making a new recording onto the tape, the operation is as follows:

1. If you wish to erase side A of the tape, insert the cassette with side A up.
2. Both Right and Left Volume Controls should be in the "0" position.
3. Press the RECORD and PLAY buttons simultaneously. This operation will erase any previous recording.

If you want to erase the other side of the tape reverse the cassette and operate in the same way.

- * Be sure to set the Volume Control in "0" position.
- * Microphones should be disconnected.
- * For best erasure, it is advisable to disconnect the leads to the input jacks from the sound source.

MAINTENANCE

For day to day maintenance, there are no complicated procedures involved. Important notes are: cleaning of "heads" and relative parts on which tape runs, and demagnetization of HEADS. Regarding oiling, once a year is sufficient for normal use. This requires a special technique so ask the advice of your local dealer.

CLEANING THE HEADS

If the face of the Heads, Pinch Roller, or Capstan on which the tape runs is dirty, then noise can be caused together with bad sound quality. Be sure to clean these parts. Before cleaning the heads or other parts, be sure to switch off the power source, and remove the cassette.

For cleaning, push the PLAY BUTTON, then you will see the heads etc., beneath it. Clean the face of the Heads, Pinch Roller and Capstan, on which the tape runs with a soft cloth moistened with spirits.

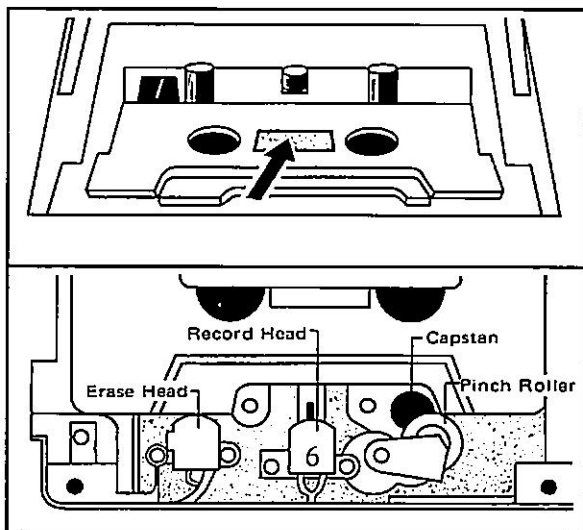

HEAD DEMAGNETIZATION

When you put such items as magnetized screw-drivers near the head, it will become magnetized, thus causing noise on playback and will possibly affect the tape as well. In the event of your set producing such noise, demagnetize the head using a HEAD DEMAGNETIZER.

Be sure to disconnect the power source before carrying out the procedure of HEAD DEMAGNETIZING.

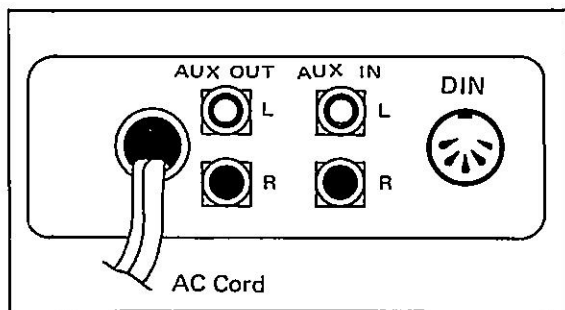

SPECIFICATIONS

Tape Section:

Tape:	Cassette Tape
Tape Speed:	4.75 cm/s
Tracks:	4 Track Stereo
Wow & Flutter:	0.1% w.r.m.s.
F.F. and Rewind Time:	110 seconds (C-60)
Record System:	AC Bias
Erasing System:	AC Erasing

Common:

Power Source:	AC 120V 60Hz
Maximum Consumption:	5W
Frequency Response:	60 — 14000 Hz (± 6 dB) for Chrome Tape 60 — 9000 Hz (± 6 dB) for Normal Tape

Total Harmonic Distortion:

2%

Semi-conductor:

15 Transistors (Tape)

10 Diodes

Input Jacks:

* Microphone Jack	— 2
Input Level	0.5mV
Low Impedance	
* Line Input Jack	— 2
Input Level	— 0.06V
Input Impedance	— 330k ohm
* DIN Jack (input side)	
Input Impedance	— 3.3k ohm

Output Jacks:

* Line Output Jack	— 2
Standard Output Voltage	0.5V
(at 47k ohm loaded)	
Load Impedance	— more than 47k ohm
* Stereo Headphone Jack	— 1
Load Impedance	— 8 ohm
* DIN Jack (output side)	
Output Impedance	— 47k ohm

Dimension:

314 (W) x 111 (H) x 231 (D) mm

Weight:

3.6kg.

