

Cambridge Audio

Service Manual

351A



Specifications

Power Output:	45 watts (into 8 ohms)
Weight:	6kg (13.2lbs)
THD (unweighted):	<0.02% @ 1kHz, 80% of rated power <0.15% 20Hz - 20kHz, 80% of rated power
Inputs:	5 x RCA, 1 x USB (type B), 1 x 3.5mm MP3 input
Outputs:	Speakers A & B, 1 x Rec Out, ¼" headphone out,
USB	USB audio 1.0 16-bit 32kHz, 44.1kHz, 48kHz
Frequency Response:	5Hz - 50kHz
S/N ratio (ref 1w):	>92dB (unweighted)
Input Impedance:	47k ohms
Max. Power Consumption:	320W
Bass/Treble controls:	Shelving, ultimate boost/cut +/-10dB @ 20Hz and +/-6dB @ 20kHz
Dimensions (H x W x D):	86 x 430 x 340mm (3.4 x 16.9 x 13.4")

Contents

Important safety instructions	2
Rear panel connections.....	4
Front panel controls.....	5
Remote control.....	6
Connections.....	7
Technical specifications.....	9
Troubleshooting.....	9
Packaging exploded diagram	10
Front panel exploded diagram	10
Unit exploded diagram.....	11
Main PCB Schematics - Tone Circuit.....	12
Main PCB Schematics - Power Amps.....	13
Main PCB Schematics - Power Supply	14
Main PCB Schematics - iPod Stage.....	15
Main PCB Schematics - Parts for Bom	16
Main PCB Gerbers.....	17
Main PCB BOM.....	18
Main PCB BOM.....	20
Microcontroller PCB Schematics.....	22
Microcontroller Gerbers.....	23
Microcontroller PCB BOM	24
USB PCB Schematic.....	25
USB PCB Gerber	26
USB PCB BOM	27
IC details	29

Important safety instructions

For your own safety please read the following important safety instructions carefully before attempting to connect this unit to the mains power supply. They will also enable you to get the best performance from and prolong the life of the unit:

1. Read these instructions.
2. Keep these instructions.
3. Heed all warnings.
4. Follow all instructions.
5. Do not use this apparatus near water.
6. Clean only with a dry cloth.
7. Do not block any ventilation openings. Install in accordance with the manufacturer's instructions.
8. Do not install near any heat sources such as radiators, heat registers, stoves, or other apparatus (including amplifiers) that produce heat.
9. Do not defeat the safety purpose of the polarized or grounding-type plug. A polarized plug has two blades with one wider than the other. A grounding-type plug has two blades and a third grounding prong. The wide blade or the third prong are provided for your safety. If the provided plug does not fit into your outlet, consult an electrician for replacement of the obsolete outlet.
10. Protect the power cord from being walked on or pinched, particularly at plugs, convenience receptacles and the point where they exit from the apparatus.
11. Only use attachments/accessories specified by the manufacturer.
12. Use with only the cart, stand, tripod, bracket, or table specified by the manufacturer, or sold with the apparatus. When a cart is used, use caution when moving the cart/ apparatus combination to avoid injury from tip-over. 
13. Unplug this apparatus during lightning storms or when unused for long periods of time.
14. Refer all servicing to qualified service personnel. Servicing is required when the apparatus has been damaged in any way, such as the power-supply cord or plug having been damaged, liquid has been spilled or objects have fallen into the apparatus, the apparatus has been exposed to rain or moisture, does not operate normally, or has been dropped.

WARNING

- To reduce the risk of fire or electric shock, do not expose this unit to rain or moisture.
- Batteries (battery pack or batteries installed) shall not be exposed to excessive heat such as sunshine, fire or the like.

The unit is of Class 1 construction and must be connected to a mains socket outlet with a protective earthing connection.

The unit must be installed in a manner that makes disconnection of the mains plug from the mains socket outlet (or appliance connector from the rear of the unit) possible. Where the mains plug is used as the disconnect device, the disconnect device shall remain readily operable. Only use the mains cord supplied with this unit.

Please ensure there is ample ventilation (at least 10cm clearance all round). Do not put any objects on top of this unit. Do not situate it on a rug or other soft surface and do not obstruct any air inlets or outlet grilles. Do not cover the ventilation grilles with items such as newspapers, tablecloths, curtains, etc.

This unit must not be used near water or exposed to dripping or splashing water or other liquids. No objects filled with liquid, such as vases, shall be placed on the unit.



The lightning flash with the arrowhead symbol within an equilateral triangle is intended to alert the user to the presence of un-insulated 'dangerous voltage' within the product's enclosure that may be of sufficient magnitude to constitute a risk of electric shock to persons.

The exclamation point within an equilateral triangle is intended to alert the user to the presence of important operating and maintenance instructions in the service literature relevant to this appliance.



WEEE symbol

The crossed-out wheeled bin is the European Union symbol for indicating separate collection for electrical and electronic equipment. This product contains electrical and electronic equipment which should be reused, recycled or recovered and should not be disposed of with unsorted regular waste.

Please return the unit or contact the authorised dealer from whom you purchased this product for more information.



CE mark

This product complies with European Low Voltage (2006/95/EC), Electromagnetic Compatibility (2004/108/EC) and Environmentally-friendly design of Energy-related Products (2009/125/EC) Directives when used and installed according to this instruction manual. For continued compliance only Cambridge Audio accessories should be used with this product and servicing must be referred to qualified service personnel.



C-Tick mark

This product meets the Australian Communications Authority's Radio communications and EMC requirements.



Gost-R Mark

This product meets Russian electronic safety approvals.

FCC regulations

NOTE: THE MANUFACTURER IS NOT RESPONSIBLE FOR ANY RADIO OR TV INTERFERENCE CAUSED BY UNAUTHORIZED MODIFICATIONS TO THIS EQUIPMENT. SUCH MODIFICATIONS COULD VOID THE USER AUTHORITY TO OPERATE THE EQUIPMENT.



This equipment has been tested and found to comply with the limits for a Class B digital device, pursuant to Part 15 of the FCC Rules. These limits are designed to provide reasonable protection against harmful interference in a residential installation. This equipment generates, uses and can radiate radio frequency energy and, if not installed and used in accordance with the instructions, may cause harmful interference to radio communications. However, there is no guarantee that interference will not occur in a particular installation.

If this equipment does cause harmful interference to radio or television reception, which can be determined by turning the equipment off and on, the user is encouraged to try to correct the interference by one or more of the following measures:

- Re-orient or relocate the receiving antenna.
- Increase the separation between the equipment and receiver.
- Connect the equipment into an outlet on a circuit different from that to which the receiver is connected.
- Consult the dealer or an experienced radio/TV technician for help.

Ventilation

IMPORTANT – The unit will become hot when in use. Do not stack multiple units on top of each other. Do not place in an enclosed area such as a bookcase or in a cabinet without sufficient ventilation.

Ensure that small objects do not fall through any ventilation grille. If this happens, switch off immediately, disconnect from the mains supply and contact your dealer for advice.

Positioning

Choose the installation location carefully. Avoid placing it in direct sunlight or close to a source of heat. No naked flame sources, such as lighted candles, should be placed on the unit. Also avoid locations subject to vibration and excessive dust, cold or moisture. The unit can be used in a moderate climate.

This unit must be installed on a sturdy, level surface. Do not place in a sealed area such as a bookcase or in a cabinet. Do not place the unit on an unstable surface or shelf. The unit may fall, causing serious injury to a child or adult as well as serious damage to the product. Do not place other equipment on top of the unit.

Due to stray magnetic fields, turntables or CRT TVs should not be located nearby due to possible interference.

Electronic audio components have a running in period of around a week (if used several hours per day). This will allow the new components to settle down and the sonic properties will improve over this time.

Power sources

The unit should be operated only from the type of power source indicated on the marking label. If you are not sure of the type of power-supply to your home, consult your product dealer or local power company.

To turn the unit off, switch off on the front panel. If you do not intend to use this unit for a long period of time, unplug it from the mains socket.

Overloading

Do not overload wall outlets or extension cords as this can result in a risk of fire or electric shock. Overloaded AC outlets, extension cords, frayed power cords, damaged or cracked wire insulation and broken plugs are dangerous. They may result in a shock or fire hazard.

Be sure to insert each power cord securely. To prevent hum and noise, do not bundle the interconnect leads with the power cord or speaker leads.

Cleaning

To clean the unit, wipe its case with a dry, lint-free cloth. Do not use any cleaning fluids containing alcohol, ammonia or abrasives. Do not spray an aerosol at or near the unit.

Battery disposal

Batteries may contain substances harmful to the environment. Please dispose of any discharged batteries with due consideration and in accordance with local environmental/electronic recycling guidelines.

Loudspeakers

Before making any connections to loudspeakers, make sure all power is turned off and only use suitable interconnects.

Servicing

These units are not user serviceable. Never attempt to repair, disassemble or reconstruct the unit if there seems to be a problem. A serious electric shock could result if this precautionary measure is ignored. In the event of a problem or failure, please contact your dealer.

Rear panel connections

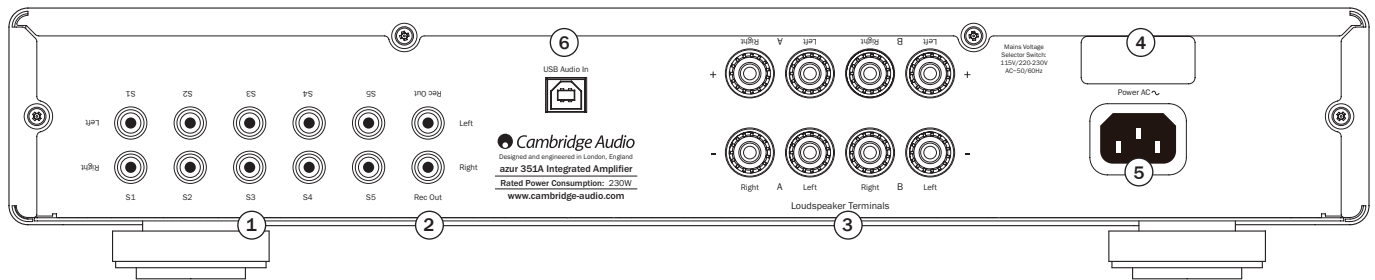

① S1-S5

These inputs are suitable for any 'line level' source equipment such as BD/DVD players, DAB or FM/AM tuners, CD players, Network Players, iPod docks, MP3 players, etc.

Note: These inputs are for analogue audio signals only. They should not be connected to the digital output of a CD player or any other digital device.

Connecting a turntable

If it is desired to connect a turntable without a built-in phono stage, an external phono stage such as our 551P or 651P models should be used. Contact your Cambridge Audio dealer for more details.

Note: A very few turntables have built-in phono stages, in which case it is not necessary to use a separate phono stage amplifier. If you're unsure, please consult your turntable user manual.

② Record Out

These output sockets can be connected to a tape deck or to the analogue Record In sockets on a MiniDisc or CD recorder.

③ Loudspeaker terminals

Two sets of loudspeaker terminals are available, A (main loudspeaker terminals, left terminals) and B (secondary switchable loudspeaker terminals, right terminals). Connect the wires from your left channel loudspeaker to the LEFT positive and negative terminals, and the wires from the right channel loudspeaker to the RIGHT positive and negative terminals. In each case, the red terminals are the positive outputs and the black terminals are the negative outputs.

Care should be taken to ensure no stray strands of wire are shorting speaker outputs together. Please ensure that the loudspeaker terminals have been tightened adequately to provide a good electrical connection. It is possible for the sound quality to be affected if the screw terminals are loose.

The use of A and B speakers affords you an easy and inexpensive way to create a simple multi-room system.

Note: When using two pairs of speakers, use speakers with a nominal impedance of 8ohms.

④ Mains voltage selector switch

Switches the mains voltage between 115V and 220-230V. For use by installer/dealer only.

⑤ AC power socket

Once you have completed all connections to the amplifier, plug the AC power cable into an appropriate mains socket and turn the unit on. Your amplifier is now ready for use.

⑥ USB interface

A USB B type socket is fitted to the 351A to enable the playback of audio from a personal computer running either Microsoft Windows or Apple Mac OS X operating systems. Some distributions of Linux are also suitable.

Note: Always use a certified cable for USB Audio preferably one that displays an official mark. USB cable connections longer than 3m may result in inconsistent audio performance.



Always turn the Volume to minimum, switch to another input or turn the 351A off before plugging/unplugging cables to the USB input or whilst booting up/shutting down your PC/Mac.

Front panel controls

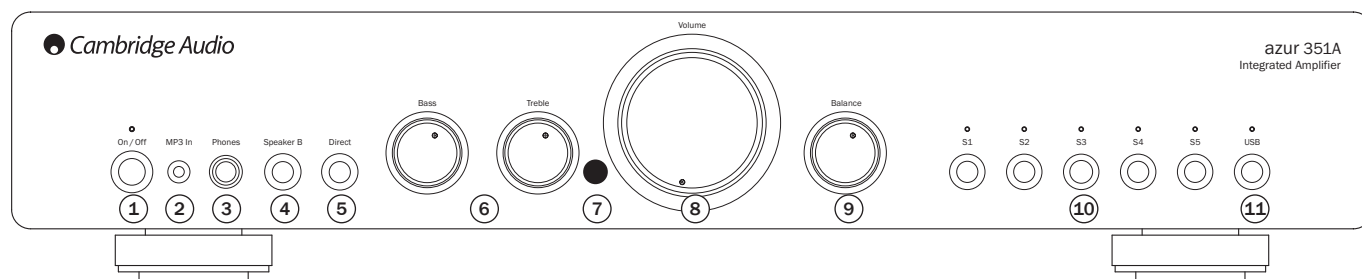

① Power On/Off

Switches the unit on or off.

② MP3 Input

This source input allows you to connect a portable audio device such as an MP3 player, plugged into either the rear panel Phono/RCA input pair (labelled 'S1') or the front panel 3.5mm stereo-jack input (labelled 'MP3 In').

Press the S1 button on the front panel to select the input, or insert a device into the front panel socket which automatically selects the input and overrides the rear Phono/RCA sockets.

③ Phones

Allows for the connection of headphones with a ¼" jack plug connector. Headphones with an impedance of between 32 and 600 ohms are recommended. When the headphones are connected, the output to the loudspeakers is switched off.

④ Speaker B

Turns on/off the secondary set of loudspeaker terminals on the back panel. This can be used for listening to an extra set of loudspeakers in another room.

Please note that care should be taken when selecting if two loudspeakers are going to be used on each channel. If the combined resistance measured on the loudspeaker terminals is too low the amplifier may not switch out of Standby mode until a suitable load resistance is detected.

Note: When using two pairs of speakers, use speakers with a nominal impedance of between 6-8 ohms each.

⑤ Direct

This control gives the audio signal a more direct path to the power amplifier stage of your amplifier, bypassing the bass and treble control circuits for the purest possible sound quality.

⑥ Bass and Treble

These controls allow subtle adjustments to the tonal balance of the

sound. In the central position these controls have no effect. They only modify the sound through your loudspeakers and do not affect the signals sent through the Rec Out connections. With a well-produced CD and a good system, the tone controls are unnecessary and can be switched out by the 'Direct' switch. If the musical recording is of poor quality or other factors are affecting the sound quality, it may be necessary to adjust the tone controls to compensate.

⑦ Infrared sensor

Receives IR commands from the supplied Azur remote control. A clear, unobstructed line of sight between the remote control and the sensor is required.

⑧ Volume

Use to increase or decrease the level of the sound from the outputs of the amplifier. This control affects the level of the loudspeaker output, the preamp output and the headphone output. It does not affect the Rec Out connections. It is advisable to turn the Volume control fully anti-clockwise before switching the amplifier on.

⑨ Balance

This control allows you to adjust the relative output levels of the left and right channels. In the central position the output from each channel is equal. This control only modifies the sound through your loudspeakers – it does not affect the signals sent through the Rec Out connections.

⑩ S1-S5 Source inputs

Push the appropriate input selection button to select the source component that you wish to listen to. The signal selected is also fed to the Rec Out sockets so that it may be recorded. The input should not be changed whilst recording.

⑪ USB

This source input allows connection of a personal computer via USB.

Remote control

The 351A is supplied with an Azur Navigator remote control that operates both this amplifier and Cambridge Audio Azur range CD players. Insert the supplied AAA batteries to activate. Always use alkaline-type batteries.

Mute

Mutes the audio on the amplifier. The mute mode is indicated by the source and speaker LEDs flashing. Press again to cancel mute.

Note: The speaker outputs, Pre-out and headphone outputs will all be muted. The Record outputs are unaffected.

Volume Up/Down

Increases or decreases the volume of the amplifier output.

Source

The six source select buttons are used to directly select the input source to the amplifier.

Note: the USB input works in a slightly different way – please refer to later section in the user's manual for details.

The remaining buttons are reserved for use with Cambridge Audio Azur CD players.

Standby/On

Switches the 351C between On and low power eco-friendly Standby mode.

Open/Close

Opens and closes the disc tray.

Numerics track select

Press the number of the desired track. The track will then play automatically from the start of the track.

Track select

To select a track number greater than nine, press -/-- followed by the track number. Playback of the chosen track starts automatically.

Play / Stop / Pause

Press the relevant button to play, stop or pause a CD.

Skip

Right Skip (▶▶) – Press to skip forward by one track on the CD.

Left Skip (◀◀) – Press to skip backward by one track on the CD.

Scan

Press and hold to scan within the selected track. Hold down for seven seconds to increase scan speed. Press the right button to fast forward, the left button to rewind.

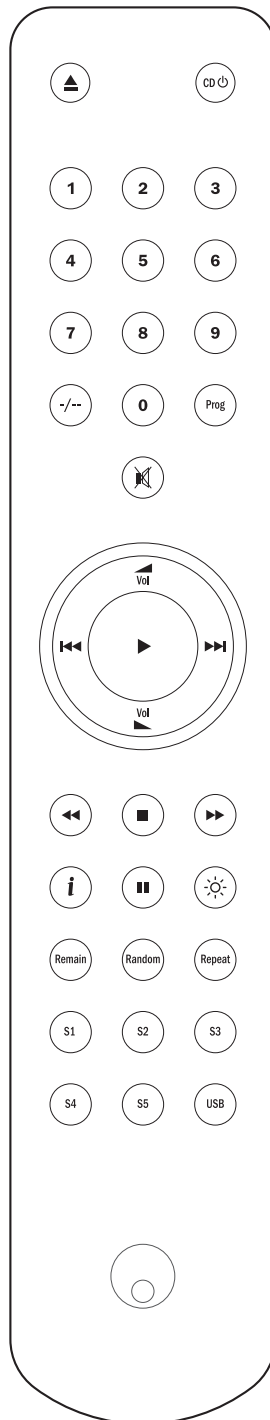

Information

Used with CDs that support CD-text. In stop mode, press to toggle between album name and total time on the display. During playback, press to toggle between track name and track time.

Bright

Alters the brightness of the 351C display backlight. There are three levels of brightness: Bright, Dim and Off.

Program, Remain, Repeat, Random,

Read the 'Operating Instructions' section of the Azur CD manual for information on the functions of these buttons.

Note: These buttons will function only when the display backlight is in either 'Bright' or 'Dim' modes. If it is set to 'Off', the functions do not respond.

Apple device compatibility

The Azur 351AC Navigator remote control can control the basic functions of Apple devices such as Apple TV and Apple's iPod/iPhone/iPad range when docked in a Cambridge Audio or Apple dock.

Press and hold the source button that corresponds to the input that the Apple product is connected to whilst also pressing one of the buttons below.

The functions are slightly different depending on the Apple product.

 Select

 Play/pause

 Stop or Menu

 Press briefly to skip or navigate left or right. Press and hold to scan forwards or backwards.

 Used to control volume and/or navigate menus.

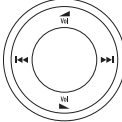
 Used to navigate menus.

In addition, the Azur remote can be paired with up to six specific Apple devices using any of the six source buttons. This can be useful if you have more than one Apple product.

For more information on pairing refer to your Apple device's instruction manual.

Pairing – To pair with an Apple device, press and hold the required source button along with the ▶▶ button for six seconds. Some devices like Apple TV have visual indication once pairing is achieved.

Un-pairing – To un-pair an Apple device, press and hold any of the source buttons along with the ◀◀ button for six seconds.

Connections

Loudspeakers

Check the impedance of your speakers. When using a pair of speakers, you can use types with an impedance of between 4 and 8 Ohms.

The red coloured speaker terminals are positive (+) and the black speaker terminals are negative (-). Make sure correct polarity is maintained at each speaker connector or the sound can become weak and “phasey” with little bass.

Using bare wire connections

Prepare the speaker cords for connection by stripping off approximately 10mm (3/8”) or less of the outer insulation. More than 10mm could cause a short circuit. Twist the wires tightly together so there are no loose ends. Unscrew the speaker terminal, insert the speaker cable, tighten the terminal and secure the cable.



Note: All connections are made using standard loudspeaker cable.

Basic connection

The diagram below shows the basic connection of your unit to a CD player and a pair of loudspeakers.

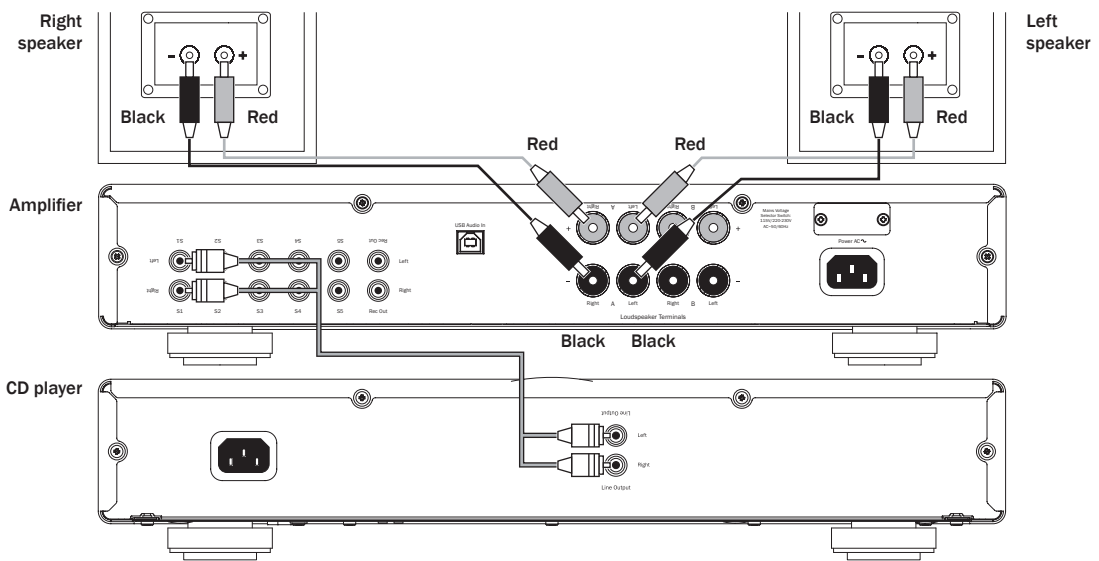

Record out connection

The diagram below shows how to connect the amplifier to a tape recorder or other component with a record function. Please note that either of the record outputs can be used (as they are both the same signal in parallel).

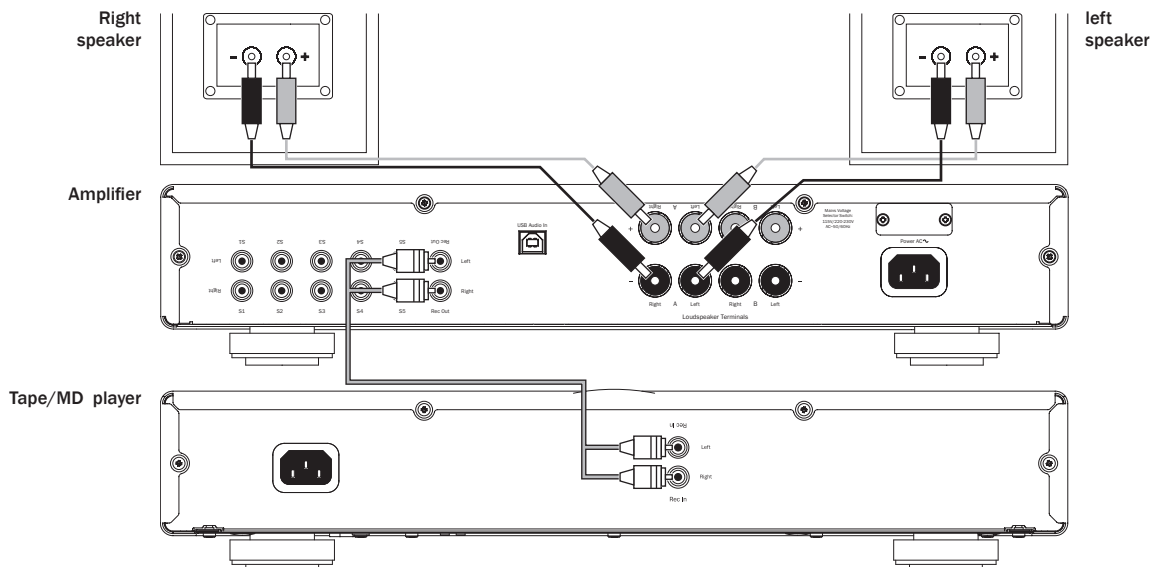

Speaker B connections

The Speaker B connections on the back of the amplifier allow for a second set of speakers to be used (i.e. speakers located in another room). The Speaker B button on the front panel allows the second set of speakers to be switched on and off

Note: When using two pairs of speakers, use speakers with a minimum nominal impedance of 8 ohms each.

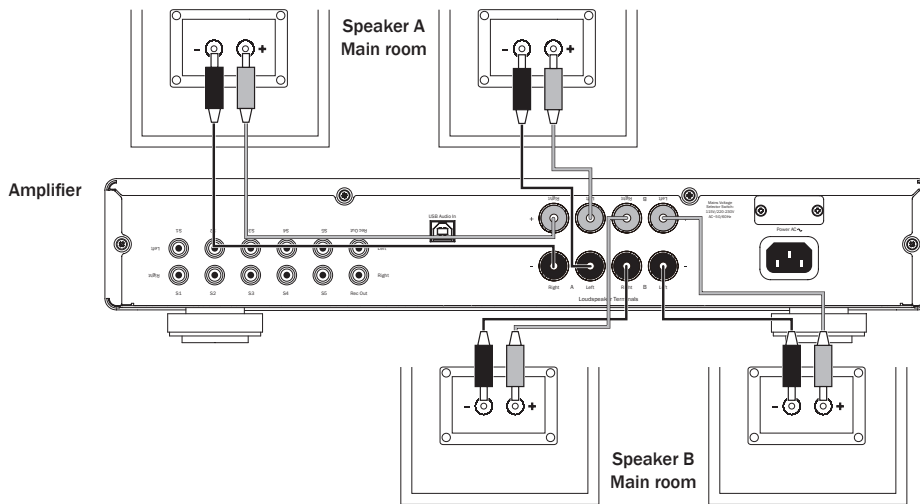

USB audio connections

The diagram below shows how to connect the amplifier to a personal computer via USB connection. Connect a USB 'A-B' type lead from the 351A USB input to one of the USB ports on the PC.

The 351A is USB 1.1 (Full-speed) USB port compatible and supports USB Audio 1.0, which works with nearly all common operating systems (Windows XP, Vista or 7 and Mac OS X 10.5 or higher) and computer types without drivers and allows 16-bit audio at 32kHz, 44.1kHz and 48kHz to be received.

The 351A also works with most distributions of Linux using the native Audio 1.0 driver. Because Linux distributions vary according to their creator's choice of software components including drivers, it is not possible to guarantee operation and Audio drivers may need to be loaded.

'Class drivers' as they are called for generic support of Audio Class 1.0 device may be available from the Linux community as we do not supply these drivers.

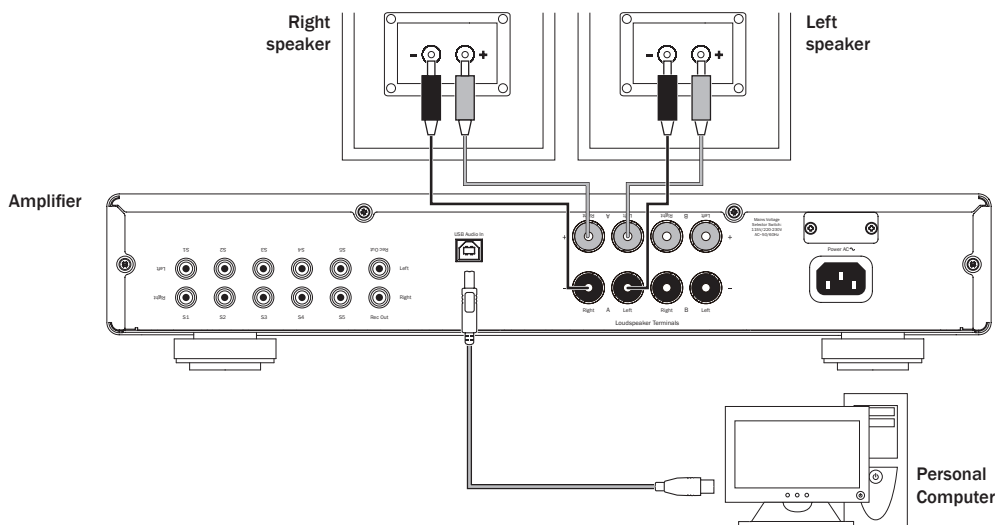

Note:

- The USB input will take approximately seven seconds to initialise once connected. Streaming will commence after this period.
- Always use a certified cable for USB Audio preferably one that displays an official mark. USB cable connections longer than 3m may result in inconsistent audio performance.



Always turn the Volume to minimum, switch to another input or turn the 351A off before plugging/unplugging cables to the USB input or whilst booting up/shutting down your PC/Mac.

Technical specifications

Power output	45 watts (into 8Ω)
THD(unweighted)	<0.02% @ 1kHz, 80% of rated power <0.15% 20Hz - 20kHz, 80% of rated power
Frequency response(+/-1dB)	5Hz to 50kHz
S/N ratio (ref 1W)	> 92dB (unweighted)
Input impedances	47k ohms
Max. power consumption	320W
Bass/Treble controls	Shelving, ultimate boost/cut +/- 10dB @ 20Hz and +/- 6dB @ 20kHz
USB input	USB Audio 1.0 16-bit 32kHz, 44.1kHz, 48kHz.
Dimensions - H x W x D	86 x 430 x 340 mm (3.4 x 16.9 x 13.4")
Weight	6.0kg (13.2lbs)

Troubleshooting

There is no power

Ensure the AC power cord is connected securely.
Ensure the plug is fully inserted into the wall socket and is switched on.
Check the unit is switched on at the rear panel.
Check fuse in the mains plug or adaptor.

There is no sound

Make sure the unit is not in Standby mode.
Check that the source component is properly connected.
Check that your speakers are properly connected.
Check that the correct speaker outputs are switched on ('Speaker B' button on the front panel).
If source LED is flashing, turn 'Mute' off.

There is no sound on one channel

Ensure that balance control is in the correct position.
Check speaker connections.
Check interconnects.

There is a loud buzz or hum

Check turntable or tone arm for ground and connection lead fault.
Ensure no interconnects are loose or defective.
Ensure that your tape deck or turntable is not too close to the amplifier.

Unable to make play tape recordings

Check that 'Rec Out' have been connected correctly.

There is weak bass or diffused stereo imaging

Ensure that speakers are not wired out of phase.

The sound is distorted

Check that the volume or tone controls are not set too high.

The remote handset will not function

Check that the batteries have not expired.
Ensure that nothing is blocking the remote sensor.

In the event that the above solutions do not remedy your problem, please consult our frequently asked questions (FAQ) section on our website: www.cambridge-audio.com/sts/faqs

For all servicing, in or out of warranty, please contact your dealer.

Packaging exploded diagram

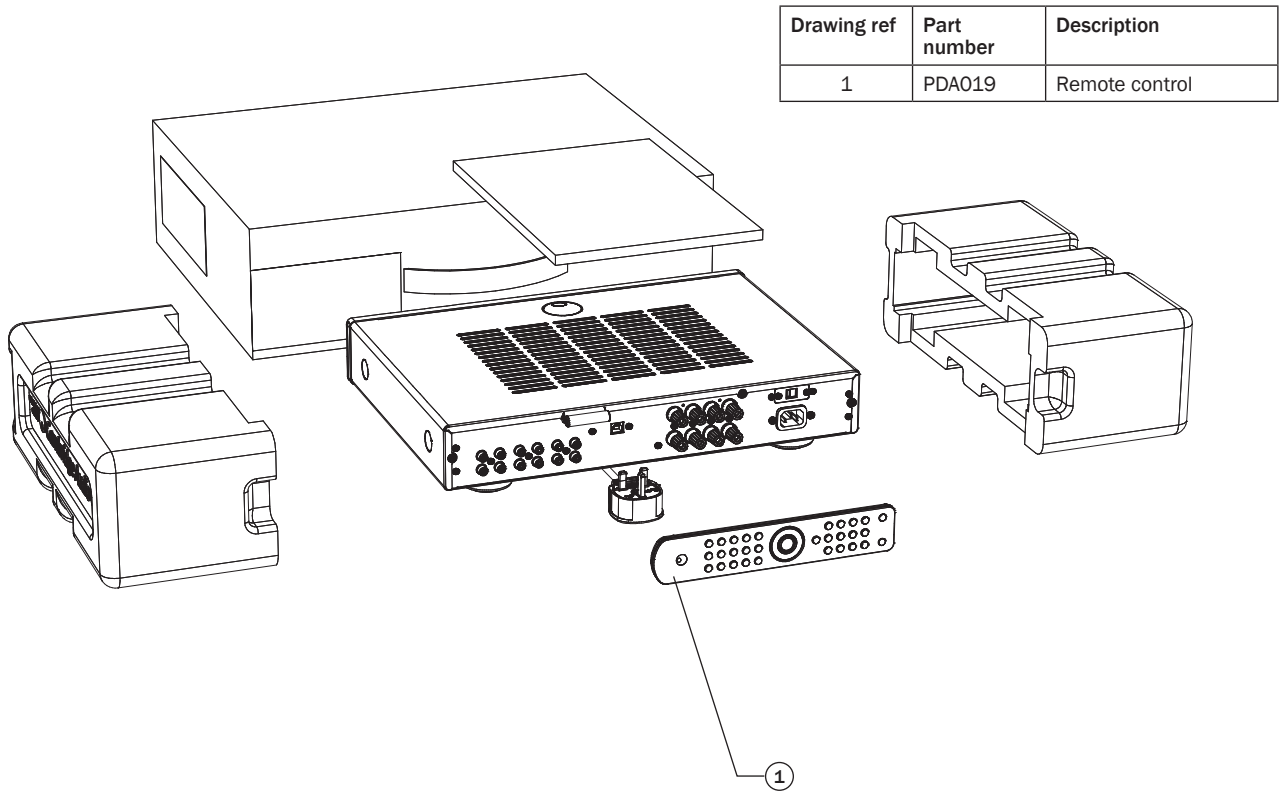

Front panel exploded diagram

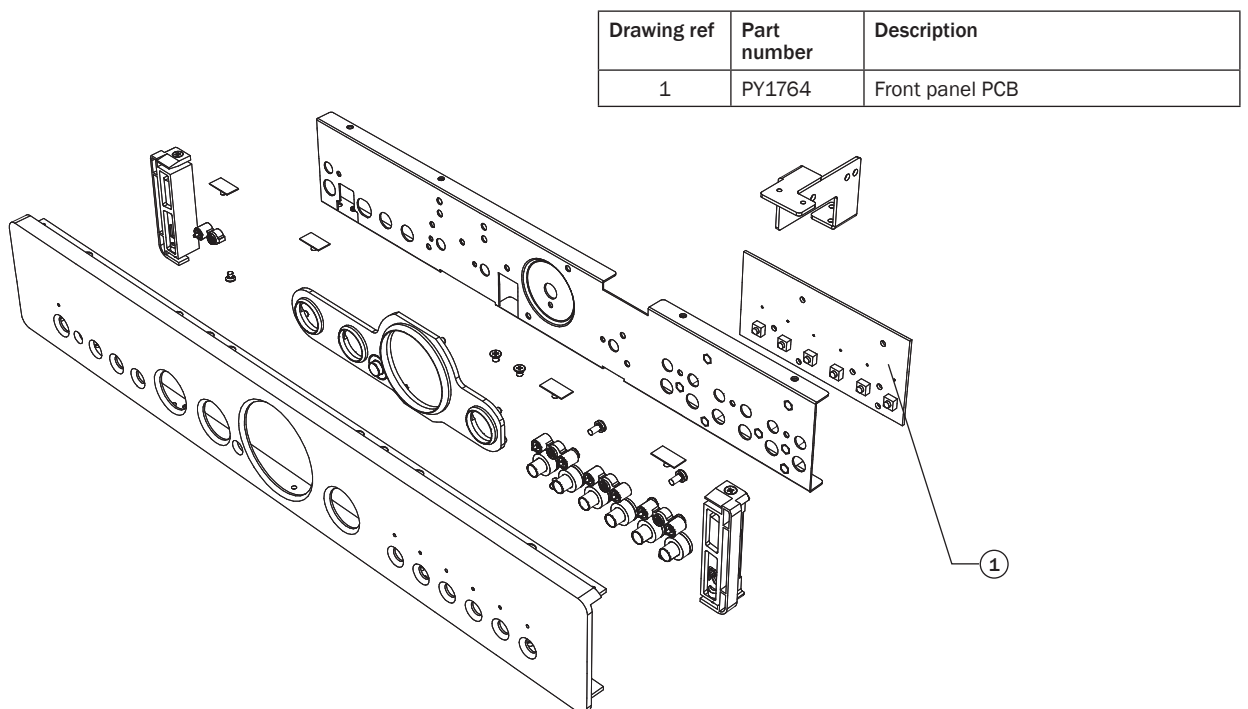

Unit exploded diagram

Drawing ref	Part numbers	Description
1	PY1758	Wrapover lid black colour
1	PY1760	Wrapover lid silver colour
2	PY1766	Toroid transformer 115V to 230V
3	PDA015	USB input PCBA
4	PDA014	Amplifier PCBA
5	PY1762	Volume board
6	PZ725	Front panel black colour
6	PZ726	Front panel silver colour

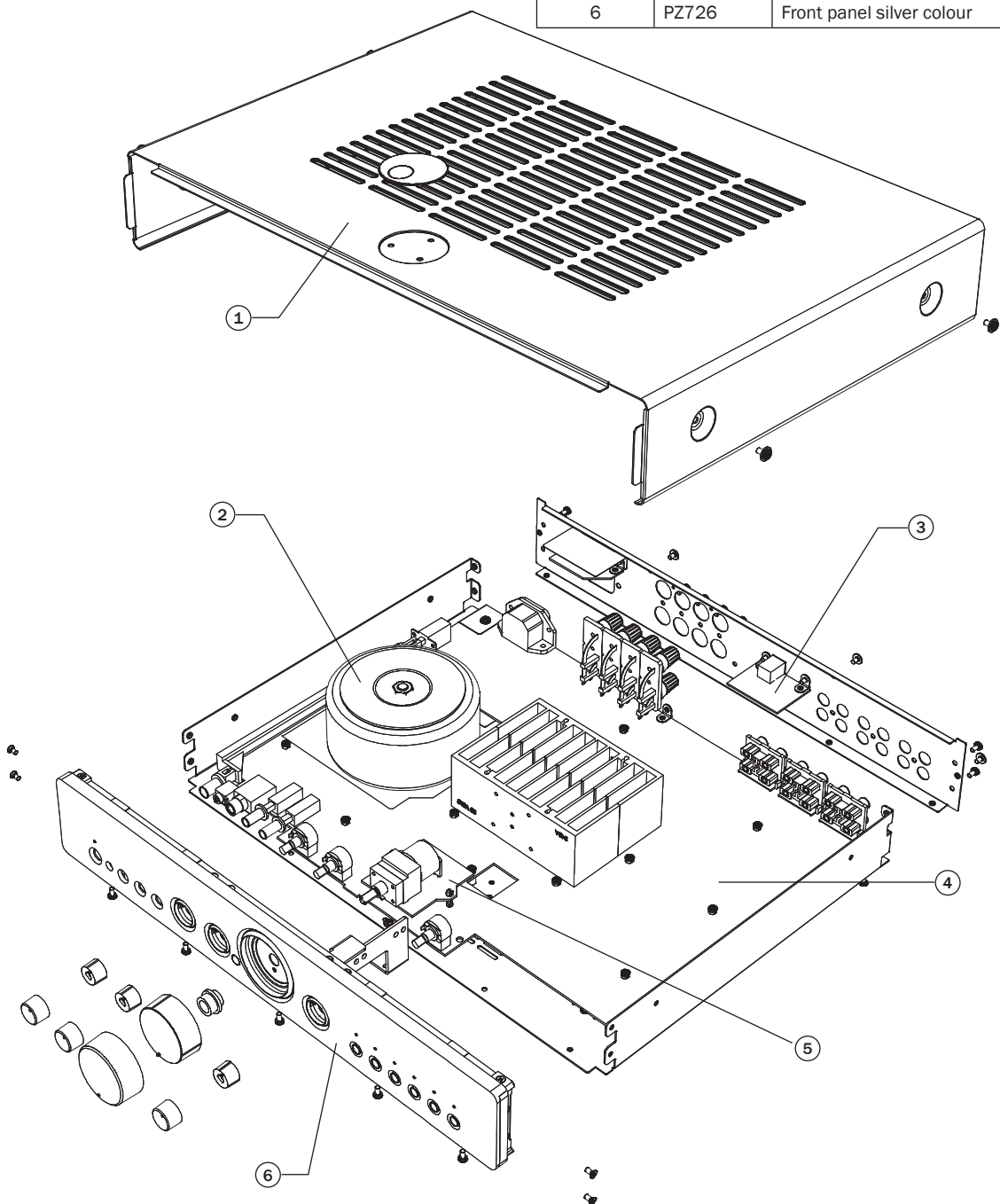

Main PCB Schematics - Tone Circuit

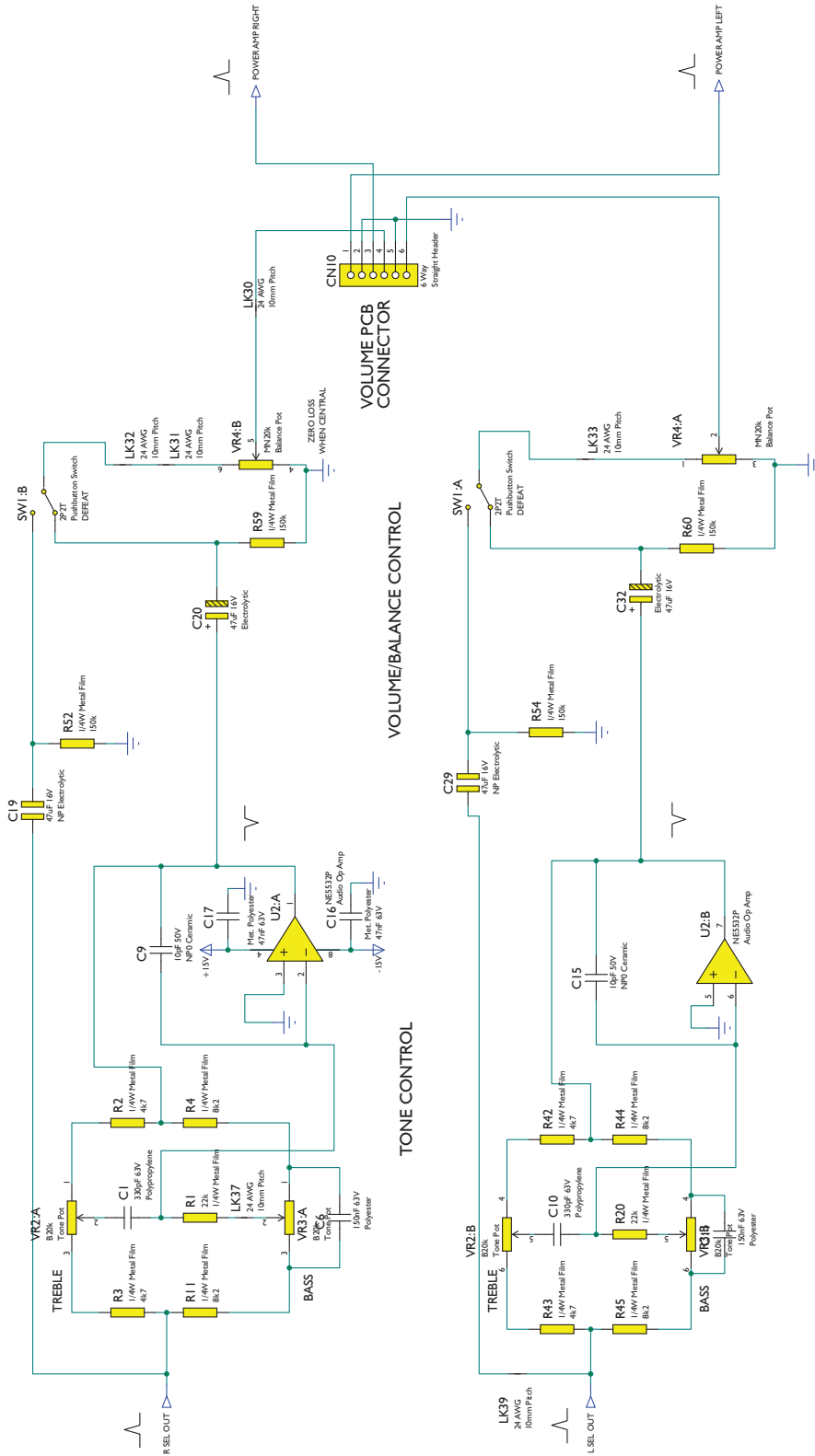

Main PCB Schematics - iPod Stage

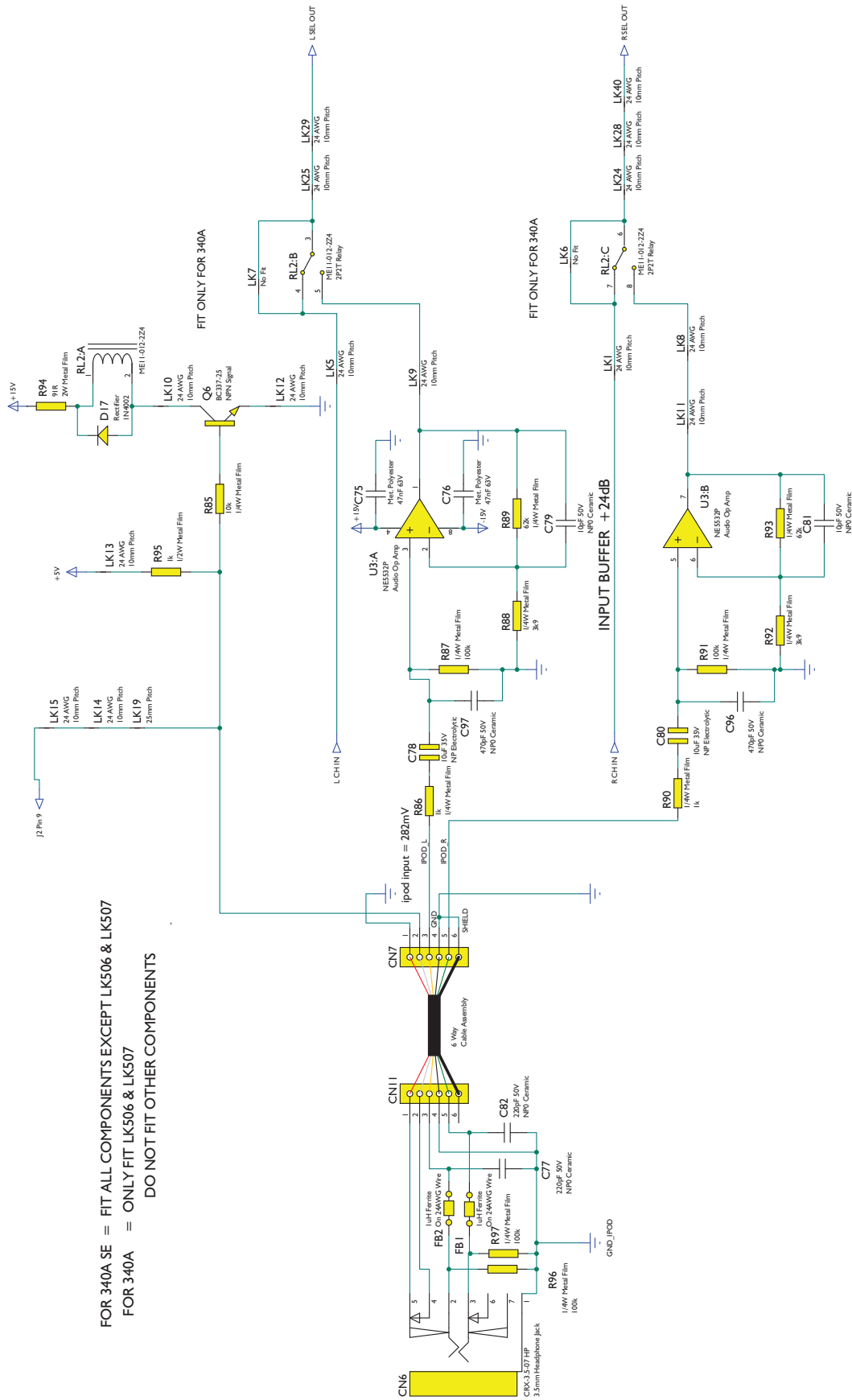

FOR 340A SE = FIT ALL COMPONENTS EXCEPT LK506 & LK507
 FOR 340A = ONLY FIT LK506 & LK507
 DO NOT FIT OTHER COMPONENTS

Main PCB Gerbers

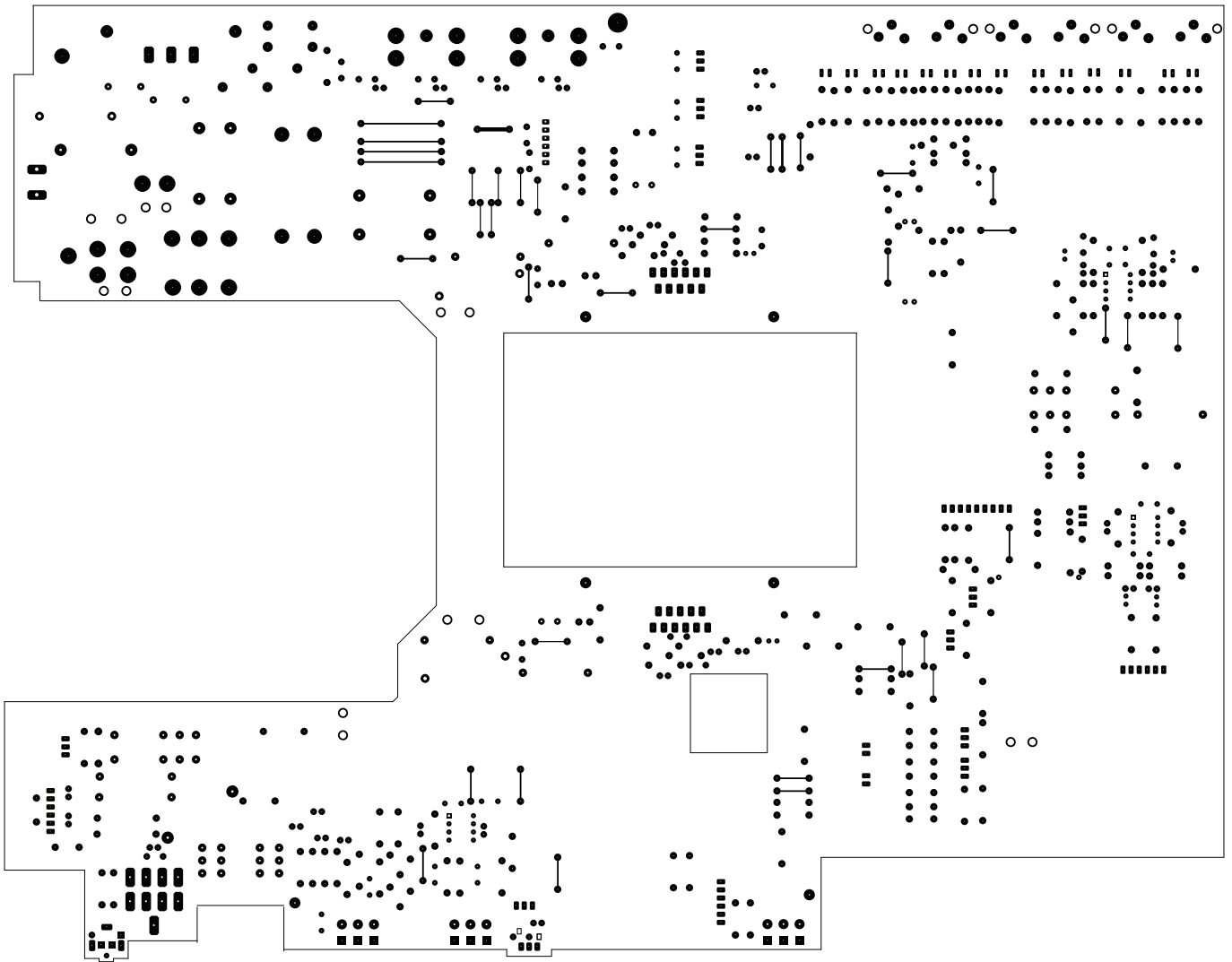

Main PCB Gerbers

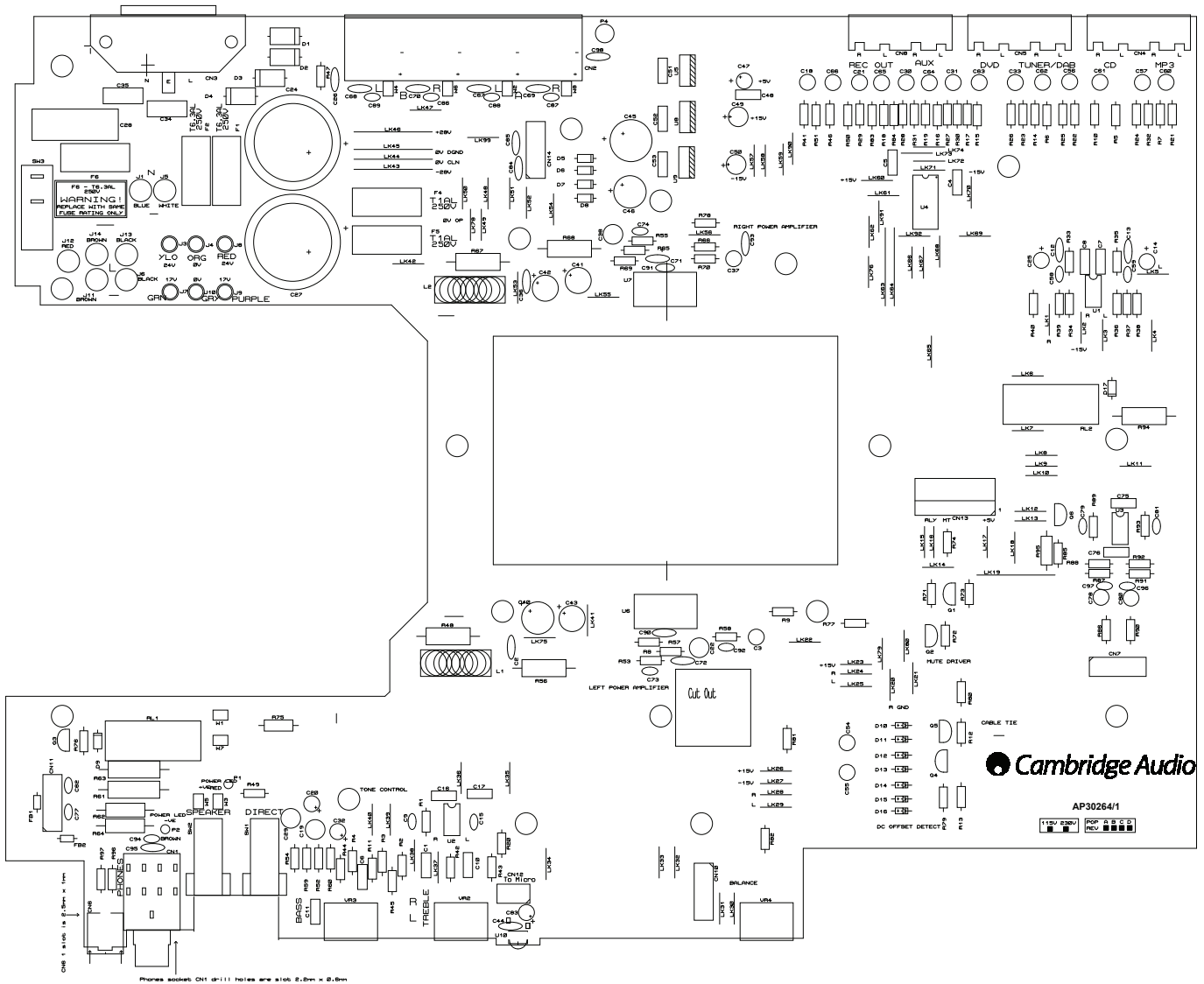

Main PCB Gerbers

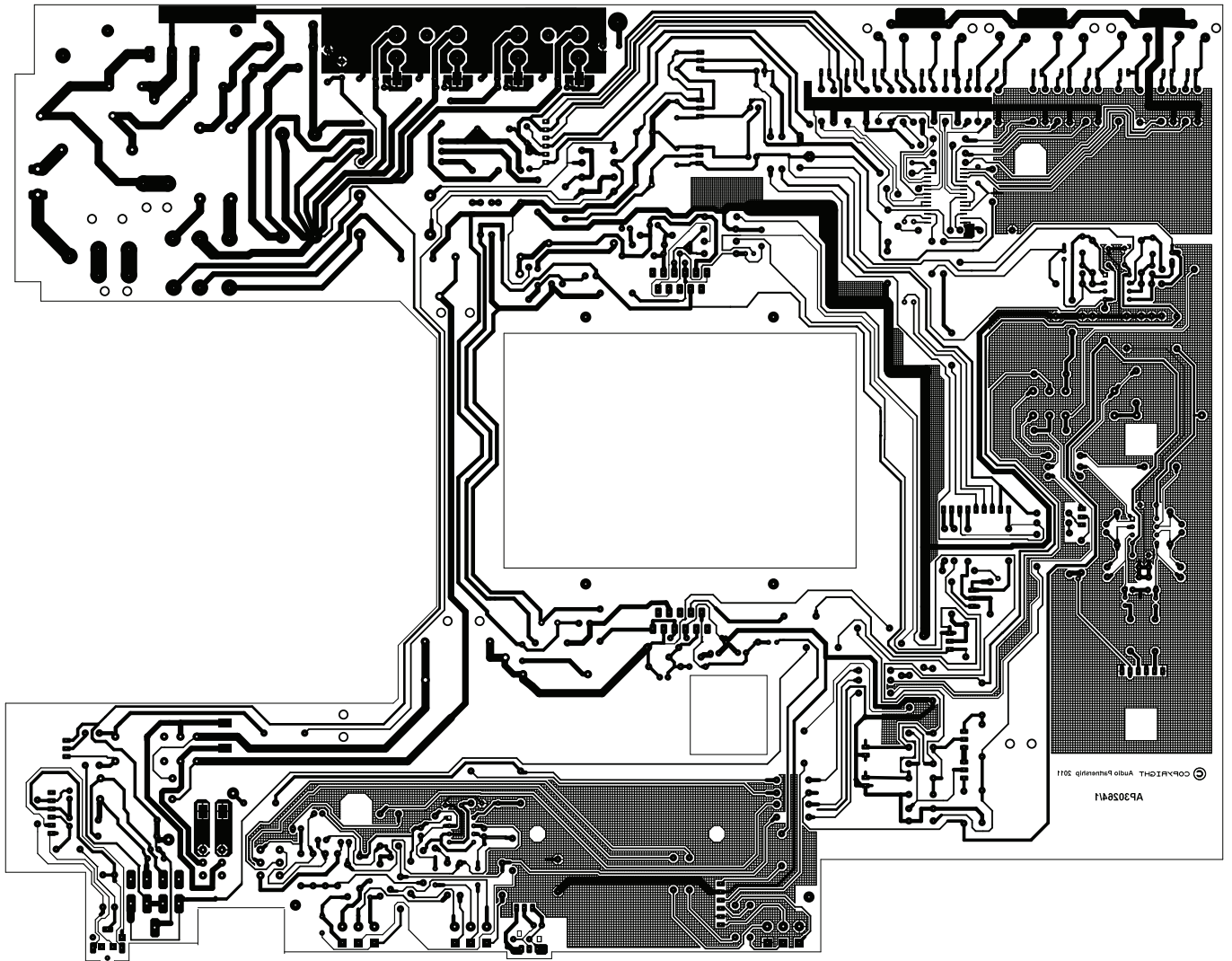

Main PCB Gerbers

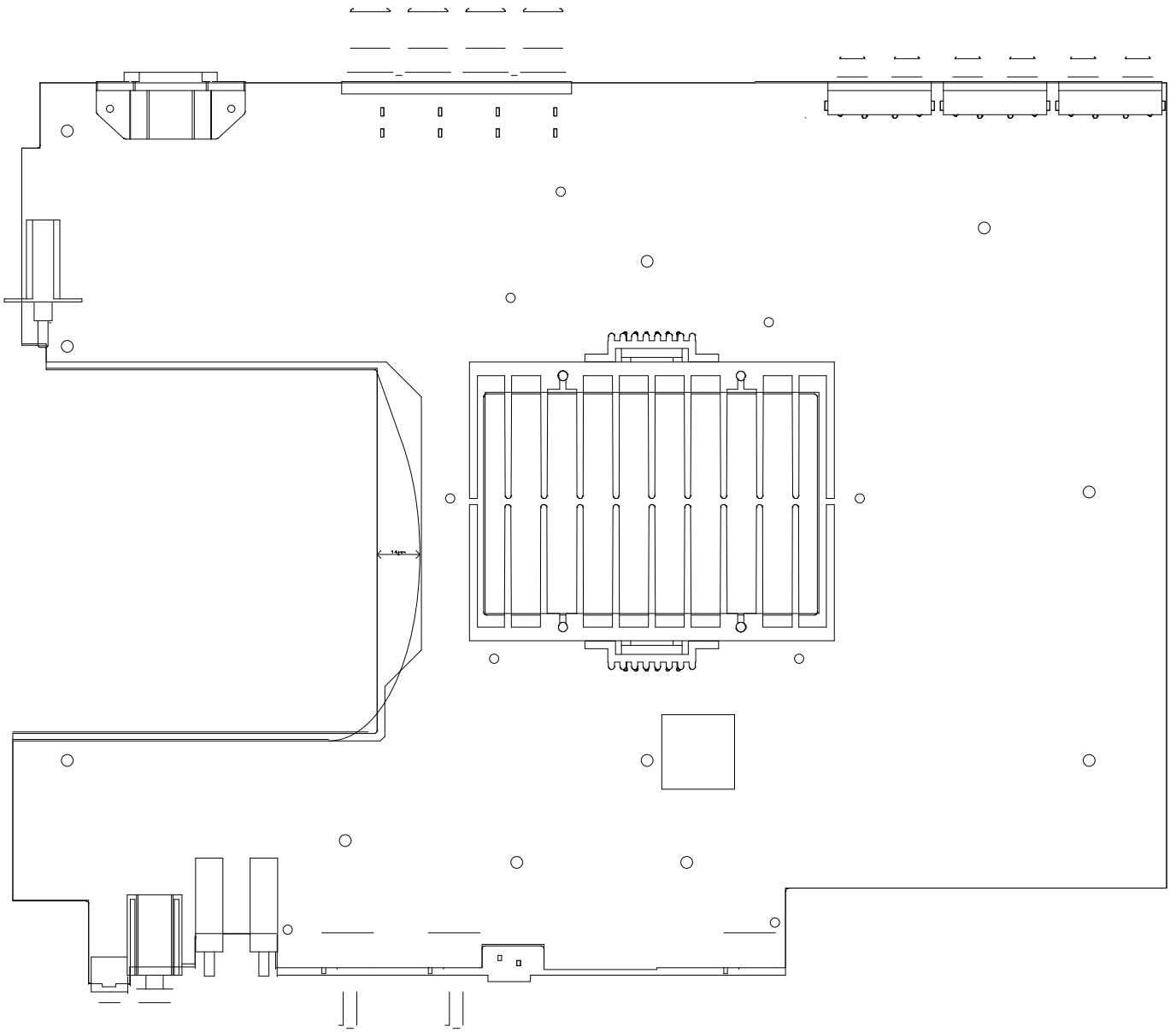

Main PCB BOM

RESISTORS

	Value	Description/Type	Qty	Component Ident	ManPN	Tolerance	PackageInfo	AP Numbers
1	2R2	2W Metal Film	2	R48, R67		1%	20mm Pitch	
2	10R	2W Metal Film	2	R56, R68		1%	20mm Pitch	
3	91R	2W Metal Film	1	R94		1%	20mm Pitch	
4	100R	1/4W Metal Film	1	R47		1%	10mm Pitch	
5	220R	3W Metal Film	2	R61, R63			22.5mm Pitch	
6	220R	1/2W Metal Film	1	R75			12.7mm Pitch	
7	470R	1W Metal Film	2	R62, R64		1%	18mm Pitch	
8	470R	1/4W Metal Film	2	R81, R82		1%	10mm Pitch	
9	1k	1/4W Metal Film	18	R7, R8, R10, R14, R17-R19, R24-R29, R41, R46, R65, R86, R90		1%	10mm Pitch	
10	1k	1/2W Metal Film	1	R95			12.7mm Pitch	
11	1k8	1/4W Metal Film	3	R13, R49, R79		1%	10mm Pitch	
12	3k9	1/4W Metal Film	4	R12, R80, R88, R92		1%	10mm Pitch	
13	4k7	1/4W Metal Film	5	R2, R3, R42, R43, R76		1%	10mm Pitch	
14	8k2	1/4W Metal Film	4	R4, R11, R44, R45		1%	10mm Pitch	
15	10k	1/4W Metal Film	5	R33-R36, R85		1%	10mm Pitch	
16	22k	1/4W Metal Film	4	R1, R20, R58, R70		1%	10mm Pitch	
17	27k	1/4W Metal Film	4	R9, R57, R66, R69		1%	10mm Pitch	
18	47k	1/4W Metal Film	4	R71-R74		1%	10mm Pitch	
19	62k	1/4W Metal Film	2	R89, R93		1%	10mm Pitch	
20	100k	1/4W Metal Film	10	R37-R40, R77, R78, R87, R91, R96, R97		1%	10mm Pitch	
21	150k	1/4W Metal Film	4	R52, R54, R59, R60		1%	10mm Pitch	
22	270k	1/4W Metal Film	16	R5, R6, R15, R16, R21-R23, R30-R32, R50, R51, R53, R55, R83, R84		1%	10mm Pitch	

RESISTORS VARIABLE

	Value	Description/Type	Qty	Component Ident	ManPN	Tolerance	PackageInfo	AP Numbers
23	B20k	Tone Pot	2	VR2, VR3	VR162G1-B20K		Dual	PY535
24	MN20k	Balance Pot	1	VR4	VR162G1-MN20K-L15F		Dual	PY1234

Note: Resistors, capacitors and other generic components are not usually stocked by the manufacturer. Please obtain these locally.

CAPACITORS

	Value	Description/Type	Qty	Component Ident	ManPN	Tolerance	PackageInfo	AP Numbers
25	No Fit		2	C23, C39				
26	NO FIT		2	C73, C74				
27	10pF 50V	NPO Ceramic	6	C9, C15, C58, C59, C79, C81		5%	2.5mm Pitch	
28	33pF 50V	NPO Ceramic	4	C12, C13, C71, C72		5%	2.5mm Pitch	
29	100pF 50V	NPO Ceramic	1	C92		5%	2.5mm Pitch	
30	100pF 50V	NPO Ceramic	1	C93		5%	CAP20	
31	220pF 50V	NPO Ceramic	2	C77, C82		5%	2.5mm Pitch	
32	330pF 63V	Polypropylene	2	C1, C10		5%	Through Hole	
33	470pF 50V	NPO Ceramic	3	C94, C96, C97		5%	2.5mm Pitch	
34	470pF 50V	NPO Ceramic	1	C95		5%	2.5mm Pitch	
35	680pF 50V	NPO Ceramic	4	C86-C89		5%	2.5mm Pitch	
36	1nF 50V	Ceramic	4	C67-C70		10%	2.5mm Pitch	
37	10nF 250V	X1/Y1 Mains Rated	2	C34, C35		20%		
38	22nF 50V	Ceramic	1	C90		10%	5mm Pitch	
39	22nF 50V	Ceramic	1	C91		10%	5mm Pitch	
40	47nF 63V	Met. Polyester	12	C4, C5, C7, C8, C16, C17, C48, C51-C53, C75, C76		10%	5mm Pitch Box	
41	100nF 100V	Mono Ceramic	4	C2, C26, C36, C44		10%	5mm Pitch	
42	100nF 100V	Mono Ceramic	3	C84, C85, C98		10%	5mm Pitch	
43	150nF 63V	Polyester	2	C6, C11			5mm Pitch Box	
44	470nF	Mains Rated X2	1	C28			22.5mm Pitch Box	
45	10uF 35V	NP Electrolytic	22	C3, C14, C18, C21, C25, C30, C31, C33, C37, C54-C57, C60-C66, C78, C80		20%	5mm Dia	
46	10,000uF 50V	Electrolytic (with CA sleeve)	2	C24, C27		20%	30mm Dia	
47	47uF 16V	NP Electrolytic	4	C19, C22, C29, C38		20%	6mm Dia	
48	47uF 16V	Electrolytic	4	C20, C32, C47, C83		20%	5mm Dia	
49	100uF 50V	Electrolytic	1	C40		20%	8mm Dia	
50	100uF 50V	Electrolytic	3	C41-C43		20%	8mm Dia	
51	100uF 25V	Electrolytic	2	C49, C50		20%	Through Hole	
52	470uF 35V	Electrolytic	1	C46		20%	Through Hole	
53	1000uF 35V	Electrolytic	1	C45		20%	Through Hole	

Note: Resistors, capacitors and other generic components are not usually stocked by the manufacturer. Please obtain these locally.

SWITCHES

	Value	Description/Type	Qty	Component Ident	ManPN	Tolerance	PackageInfo	AP Numbers
81	2P2T	Pushbutton Switch	2	SW1, SW2	PBS-22H01-T18-SL			PY645
82	Mains Rated	Power Switch	1	SW3	KDA-A04-10			

TRANSISTORS

	Value	Description/Type	Qty	Component Ident	ManPN	Tolerance	PackageInfo	AP Numbers
83	-45V 500mA	PNP Signal	2	Q1, Q4	BC327-25		T092	PY219
84	45V 300mA	NPN Signal	4	Q2, Q3, Q5, Q6	BC337-25		T092	PY214

Note: Resistors, capacitors and other generic components are not usually stocked by the manufacturer. Please obtain these locally.

Volume Control PCB Schematics

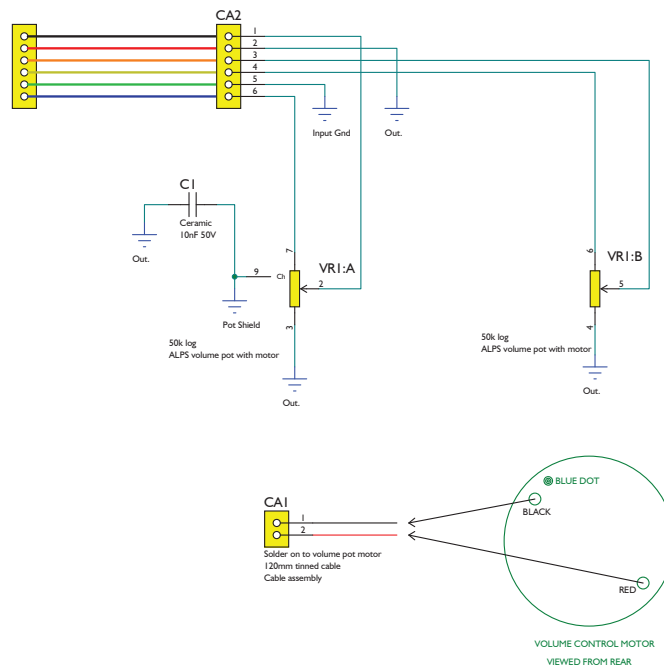

Volume Control PCB BOM

RESISTORS VARIABLE

	Value	Description/Type	Qty	Component Ident	ManPN	Tolerance	PackageInfo	Service Part Numbers
1	50k log	ALPS volume pot with motor	1	VR1	RK16812MG082		16mm	Motorised Volume Pot PY1603

CAPACITORS

	Value	Description/Type	Qty	Component Ident	ManPN	Tolerance	PackageInfo	AP Numbers
2	10nF 50V	Ceramic	1	C1	1N5402	10%	2.5mm Pitch	

MISCELLANEOUS

	Value	Description/Type	Qty	Component Ident	ManPN	Tolerance	PackageInfo	AP Numbers
3	120mm tinned cable	Cable assembly	1	CA1	AP26761/1		2.5mm Pitch	Solder on to volume pot motor
4	60mm cable assembly	Cable assembly	1	CA2	AP26762/2		2.5mm Pitch	Solder to CN1 on volume PCB

PCB

	Value	Description/Type	Qty	Component Ident	ManPN	Tolerance	PackageInfo	AP Numbers
5		AP Numbers Schematic is AP25801/3 Gerber is AP25802/1 Construction details AP25803/1 Test Procedure N/A						

Note: Resistors, capacitors and other generic components are not usually stocked by the manufacturer. Please obtain these locally.

Microcontroller PCB Schematics

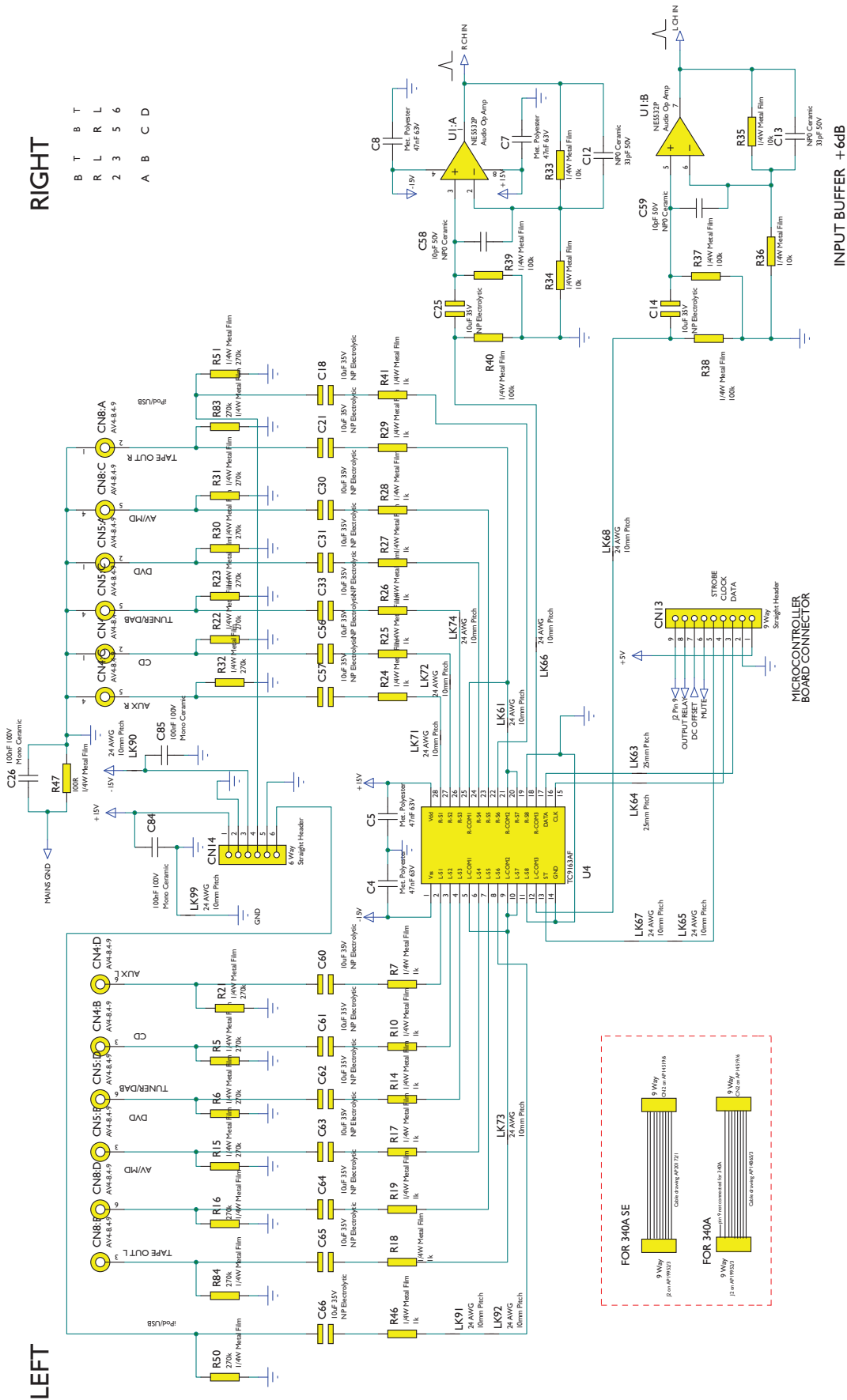

Note: Resistors, capacitors and other generic components are not usually stocked by the manufacturer. Please obtain these locally.

Microcontroller Gerbers

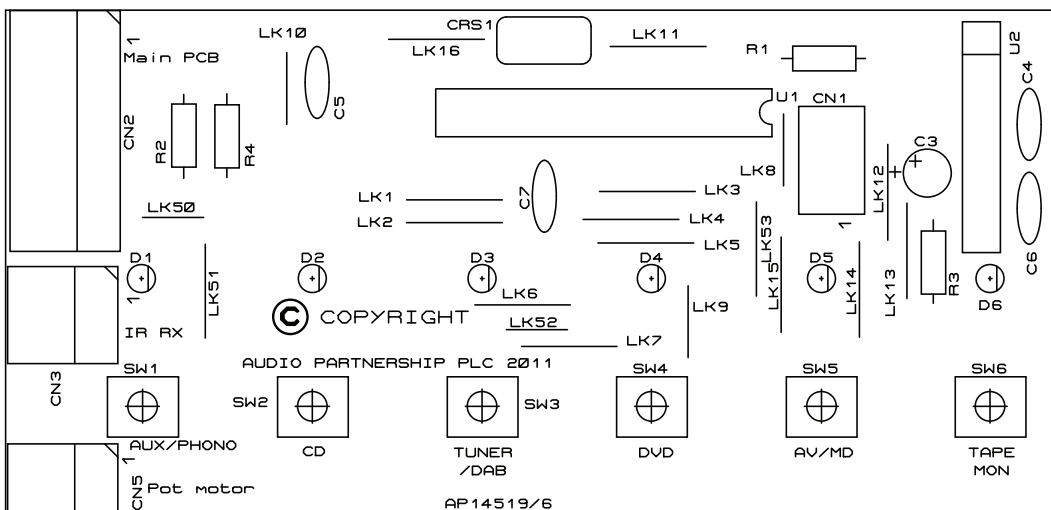
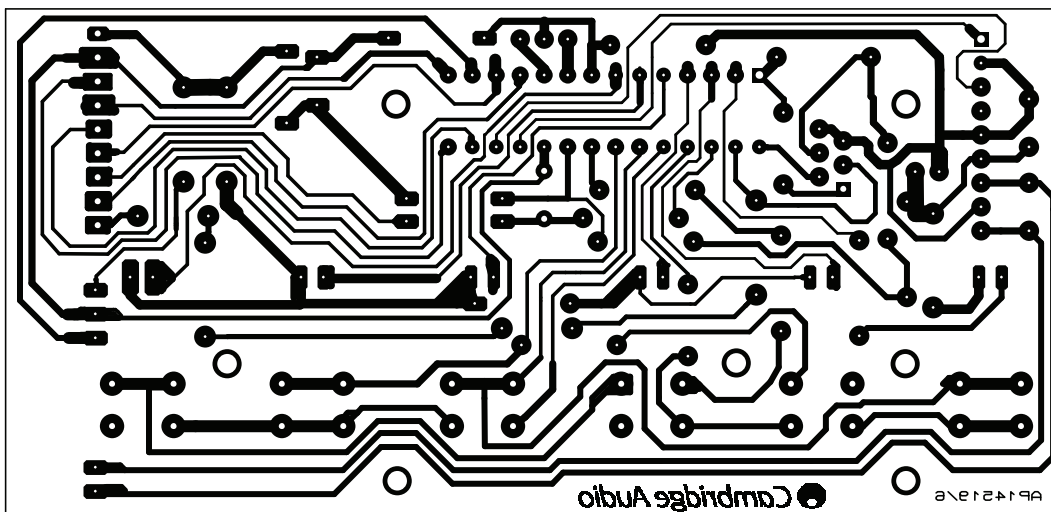
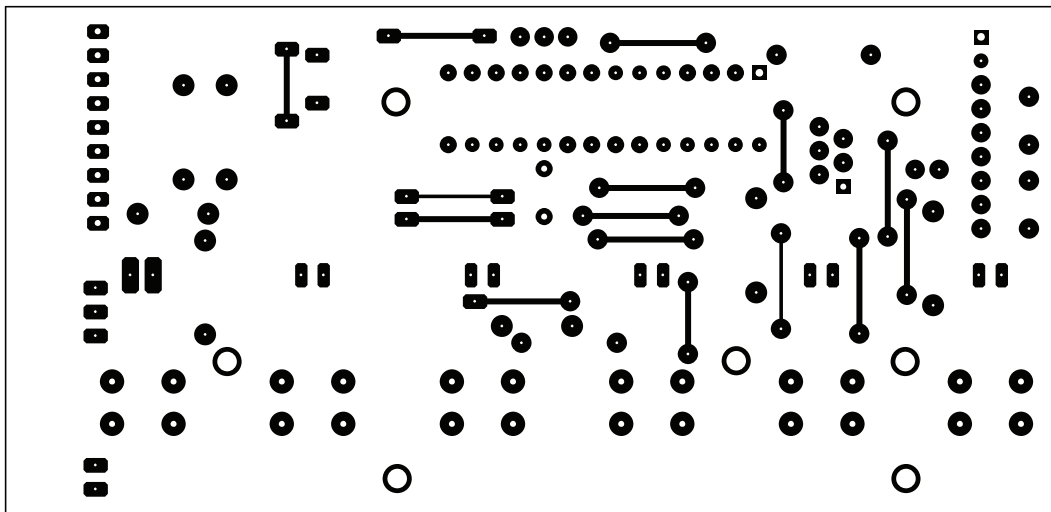

Note: Resistors, capacitors and other generic components are not usually stocked by the manufacturer. Please obtain these locally.

Microcontroller PCB BOM**RESISTORS**

	Value	Description/Type	Qty	Component Ident	AP Numbers
1	47R	Resistor 0.25W 1% metal film	1	R2	
2	220R	Resistor 0.25W 1% metal film	2	R3, R4	
3	100K	Resistor 0.25W 1% metal film	1	R1	

CAPACITORS

	Value	Description/Type	Qty	Component Ident	AP Numbers
4	100nF	Ceramic NPO or COG 10%	3	C4-C7	
5	47uF	16V Radial Electrolytic	1	C3	

SEMICONDUCTORS

	Value	Description/Type	Qty	Component Ident	AP Numbers
6	PIC16F882-I/SP	MicroController	1	U1	Programmed with AP26584/XX
7	BA6218	Motor Controller	1	U2	PY260

DIODES

	Value	Description/Type	Qty	Component Ident	AP Numbers
8	3100-000030-003	Blue Flat top LED	6	D1-D6	Please use flat top LED at standard Azur height PY064

CONNECTORS

	Value	Description/Type	Qty	Component Ident	AP Numbers
9	ICP	Picoplex PF-50 6-way male header	1	CN1	Vertical- 6-way male header
10		H9 2.54mm 90	1	CN2	Right-angle connector 9-way
11		H2 2.54mm 90	1	CN5	Right-angle connector 2-way
12		H3 2.54mm 90	1	CN3	Right-angle connector 3-way
13	NO FIT	Azur 340A IR PCB cable	1		NO FIT FOR 350A/351A PRODUCT

SWITCH

	Value	Description/Type	Qty	Component Ident	AP Numbers
14	2400-020200-000	Tactile Switch	6	SW1, 2, 3, 4, 5, 6	As used on 540A, CD, Tuner, AV, Phono/Aux, Tape/Mon, DVD PY043

Note: Resistors, capacitors and other generic components are not usually stocked by the manufacturer. Please obtain these locally.

USB PCB Schematic

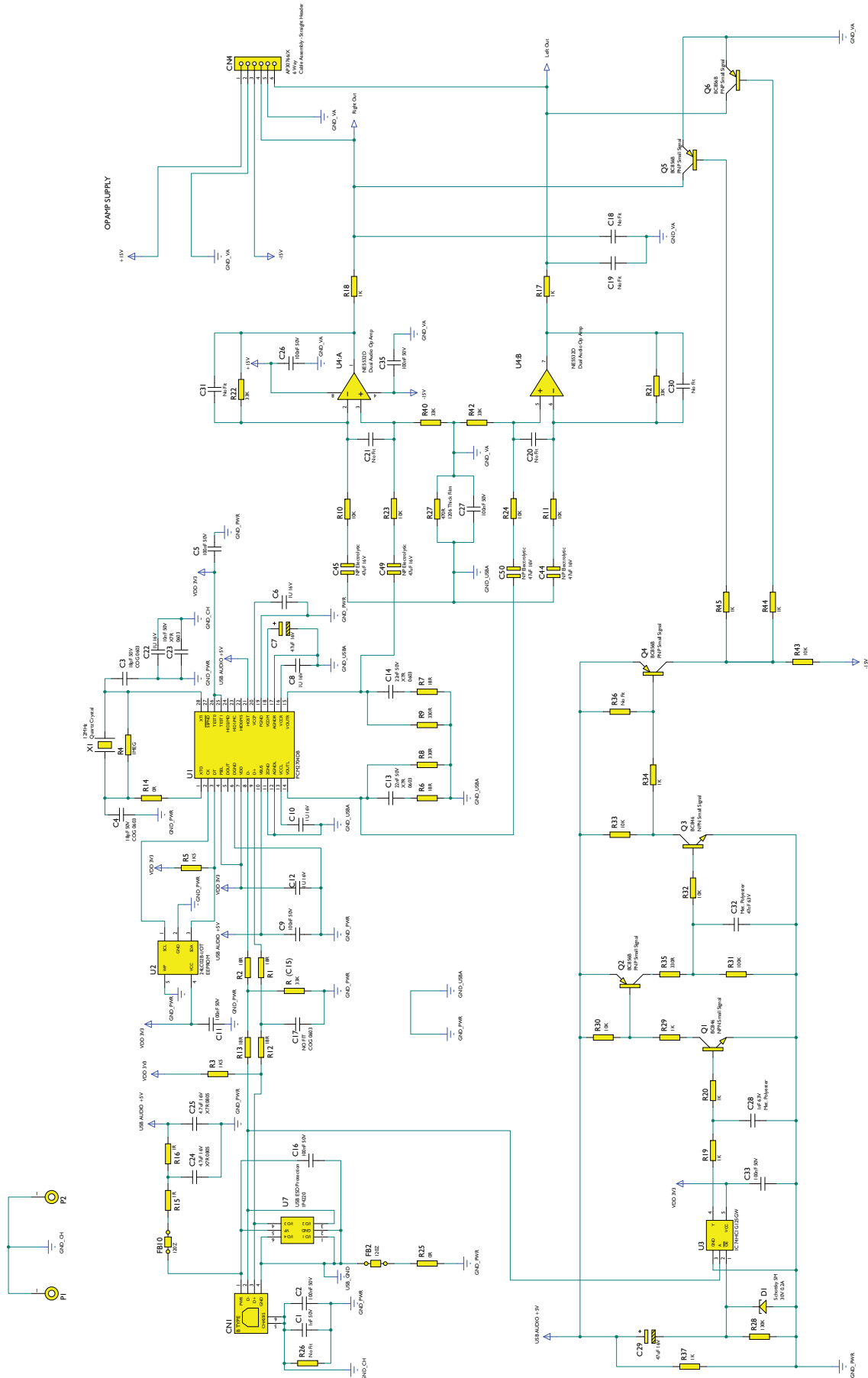

Note: Resistors, capacitors and other generic components are not usually stocked by the manufacturer. Please obtain these locally.

USB PCB Gerber

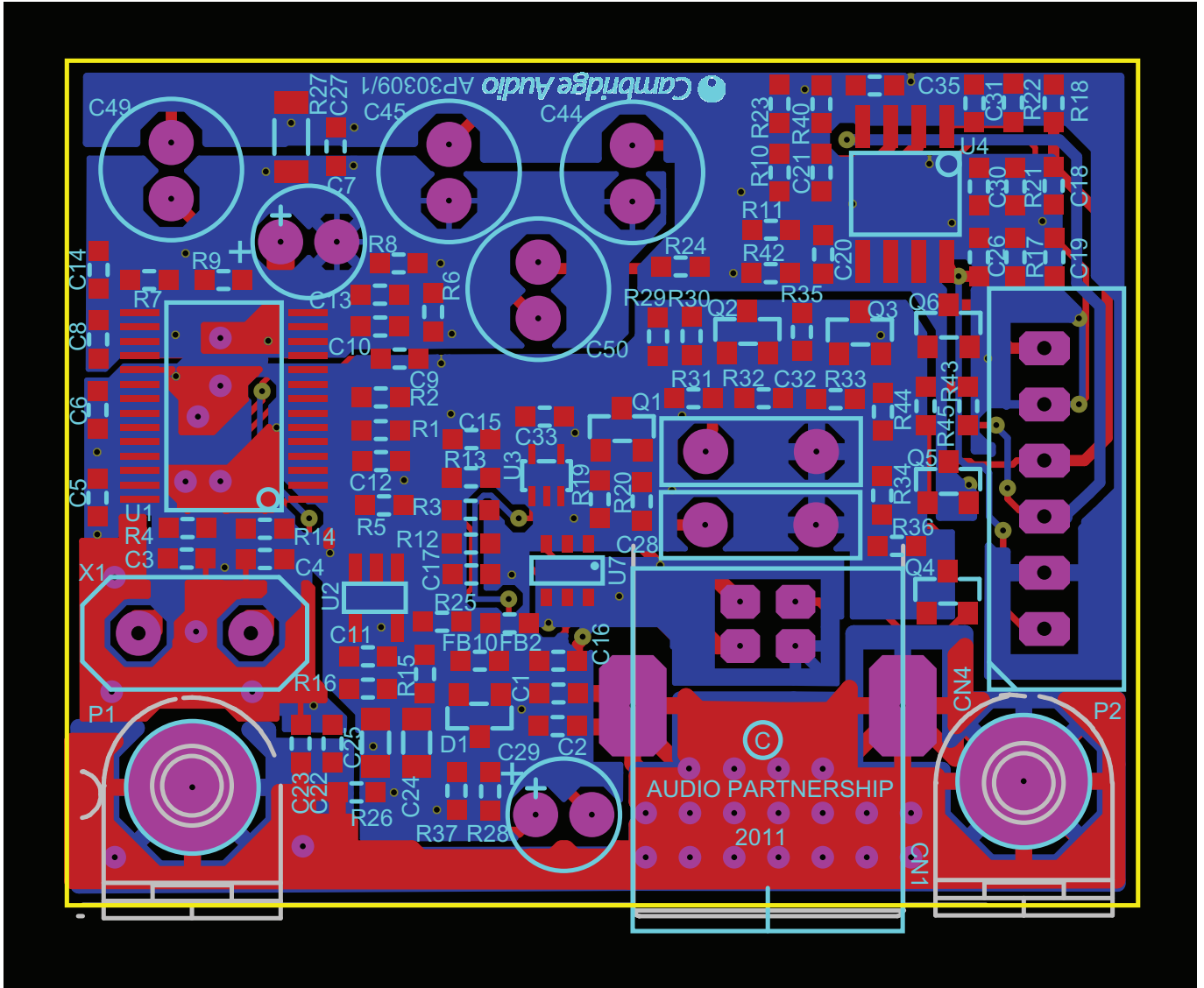

Note: Resistors, capacitors and other generic components are not usually stocked by the manufacturer. Please obtain these locally.

USB PCB BOM

RESISTORS

	Value	Description/Type	Qty	Component Ident	ManPN	Tolerance	PackageInfo	AP Number
1	0R	0603 Thick Film	2	R14, R25		1%	0603	
2	No Fit		2	R26, R36				
3	1R	0603 Thick Film	2	R15, R16		1%	0603	
4	18R	0603 Thick Film	6	R1, R2, R6, R7, R12, R13		1%	0603	
5	330R	0603 Thick Film	3	R8, R9, R35		1%	0603	
6	470R	1206 Thick Film	1	R27		1%	1206	
7	1K	0603 Thick Film	9	R17-R20, R29, R34, R37, R44, R45		1%	0603	
8	1K5	0603 Thick Film	2	R3, R5		1%	0603	
9	10K	0603 Thick Film	8	R10, R11, R23, R24, R30, R32, R33, R43		1%	0603	
10	33K	0603 Thick Film	4	R21, R22, R40, R42		1%	0603	33K also used for C15
11	100K	0603 Thick Film	1	R31		1%	0603	
12	130K	0603 Thick Film	1	R28		1%	0603	
13	1MEG	0603 Thick Film	1	R4		1%	0603	

CAPACITORS

	Value	Description/Type	Qty	Component Ident	ManPN	Tolerance	PackageInfo	AP Number
14	33K RESISTOR	0603 Thick Film	1	C15		1%	0603	As per R21, R22, R40, R42
15	NO FIT		1	C17				
16	No Fit		2	C18, C19				
17	No Fit		4	C20, C21, C30, C31				
18	18pF 50V	COG 0603	2	C3, C4		5%	0603	
19	1nF 50V	NPO	1	C1		5%	0603	
20	1nF 63V	Met. Polyester	1	C28		10%	5mm Pitch Box	
21	10nF 50V	X7R	1	C23		10%	0603	
22	22nF 50V	X7R	2	C13, C14		10%	0603	
23	47nF 63V	Met. Polyester	1	C32		10%	5mm Pitch Box	
24	100nF 50V	X7R	9	C2, C5, C9, C11, C16, C26, C27, C33, C35		10%	0603	
25	1U 16V	X5R CER 0603	5	C6, C8, C10, C12, C22		10%	0603	
26	4.7uF 16V	X7R 0805	2	C24, C25			0805	
27	47uF 16V	Electrolytic	2	C7, C29		20%	5mm Dia	
28	47uF 16V	NP Electrolytic	4	C44, C45, C49, C50		20%	6mm Dia	

Note: Resistors, capacitors and other generic components are not usually stocked by the manufacturer. Please obtain these locally.

CONNECTORS

	Value	Description/Type	Qty	Component Ident	ManPN	Tolerance	PackageInfo	AP Number
29		USB B Type	1	CN1	USB B Type 90°		Through Hole	
30	6 Way	Cable Assembly - Straight Header	1	CN4	AP30766/X		2.5mm Pitch	

CRYSTALS

	Value	Description/Type	Qty	Component Ident	ManPN	Tolerance	PackageInfo	AP Number
31	12MHz	Quartz Crystal	1	X1			HC49U	

DIODES

	Value	Description/Type	Qty	Component Ident	ManPN	Tolerance	PackageInfo	AP Number
32	30V 0.2A	Schottky SM	1	D1	BAT54		SOT23	

INDUCTORS

33	120Z	Ferrite Bead 0603	2	FB2, FB10	BLM18KG121TN1D		0603	120Z @100MHz
----	------	-------------------	---	-----------	----------------	--	------	--------------

INTEGRATED CIRCUITS

	Value	Description/Type	Qty	Component Ident	ManPN	Tolerance	PackageInfo	AP Number
34	PCM2704	16-BIT, 32/44.1/48-kHz STEREO DAC WITH USB	1	U1	PCM2704DB		SSOP 28	PF422
35	2k	EEPROM	1	U2	24LC02B-I/OT		SOT23-5	Preload with AP30822/X HEX code PY1854
36		Buffer IC	1	U3	74HC1G125GW		SOT-353	
37		Dual Audio Op Amp	1	U4	NE5532D		SOIC08	PY1162
38	IP4220	USB ESD Protection	1	U7	IP4220CZ6		SOT457	PMA118

TRANSISTORS

	Value	Description/Type	Qty	Component Ident	ManPN	Tolerance	PackageInfo	AP Number
39	65V 100mA	NPN Small Signal	2	Q1, Q3	BC846		SOT23	PY1624
40	-65V 100mA	PNP Small Signal	4	Q2, Q4-Q6	BC856B		SOT23	

Note: Resistors, capacitors and other generic components are not usually stocked by the manufacturer. Please obtain these locally.

IC details

Front Panel PCB

PIC16F72-I/SP (U1)

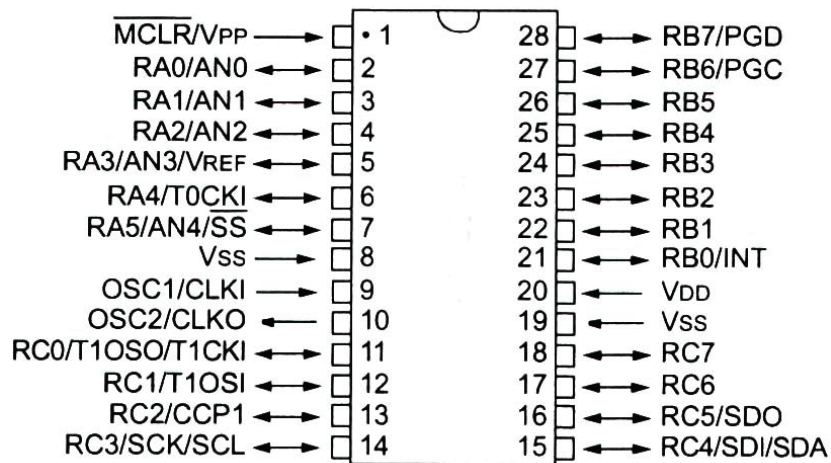

BA6218 (U2)

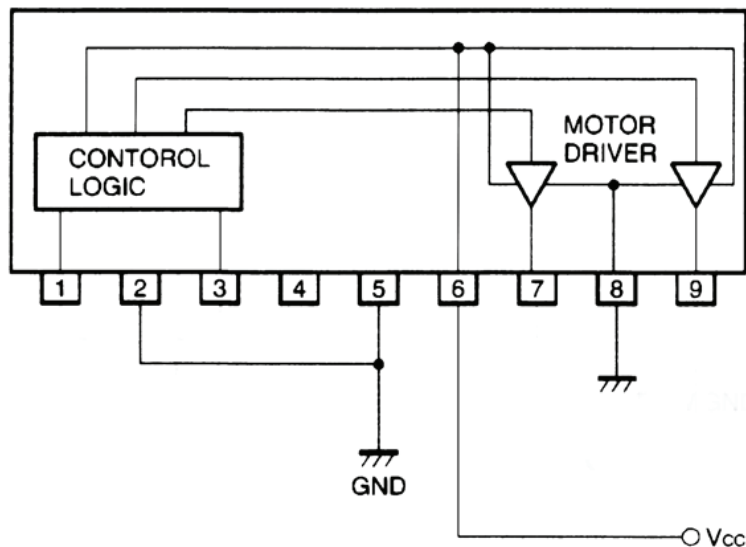

TSOP1836/37 (U3)

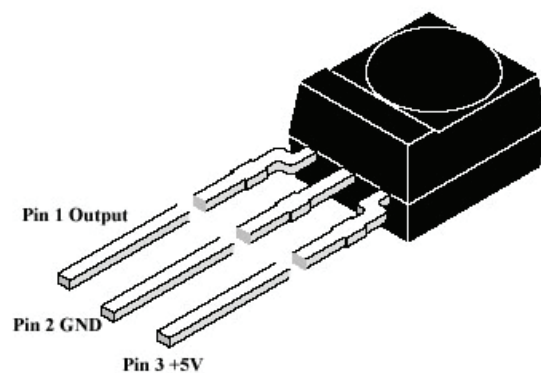

Note: Resistors, capacitors and other generic components are not usually stocked by the manufacturer. Please obtain these locally.

NE5532 (U1 & U2)

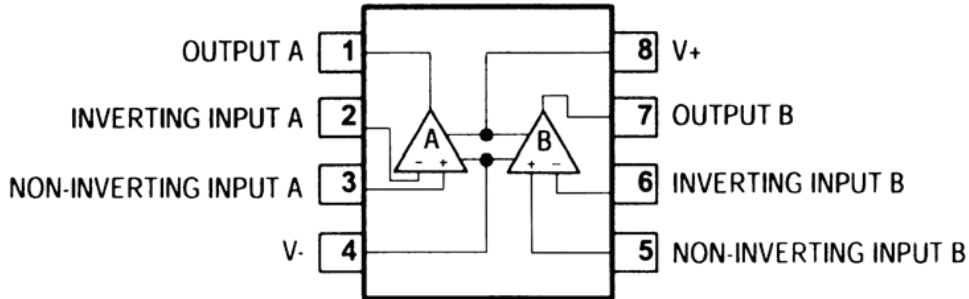

TC9163AF (U4)

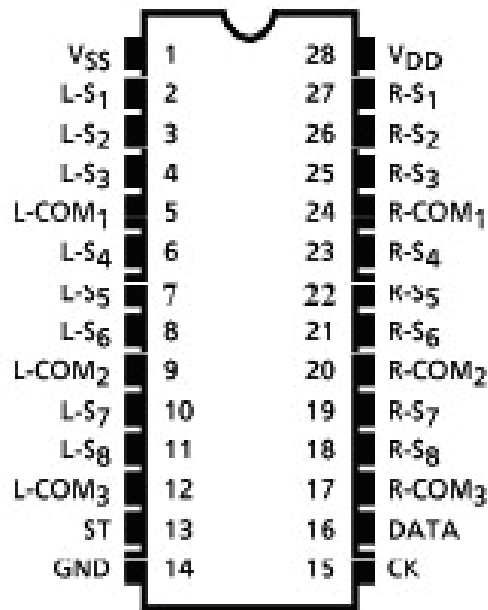

LM3886T (U6 & U7)

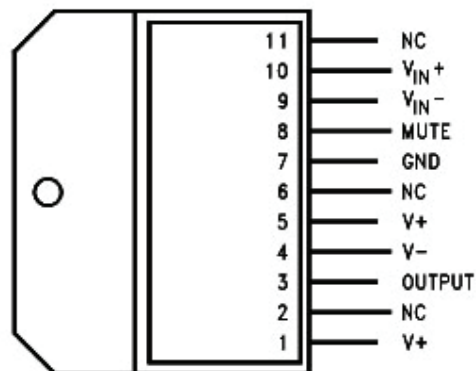

Note: Resistors, capacitors and other generic components are not usually stocked by the manufacturer. Please obtain these locally.