

First Issue Date: 29th June 2006  
 Second Issue Date: 9th October 2006  
 Third Issue Date: 02nd February 2007

## SERVICE MANUAL



### SPECIFICATIONS:

<b>Audio Section</b>			
Power Output	Front	100W RMS x 2 (8 ohm, 1% THD)	
	Centre	100W RMS (8 ohm, 1% THD)	
	Surr. (L/R)	100W RMS x 2 (8 ohm, 1% THD)	
	Surr. Back	100W RMS (8 ohm, 1% THD)	
Output Impedance	Front (L/R)	8 ohm	
	Centre	8 ohm	
	Surr. (L/R)	8 ohm	
	Surr. Back	8 ohm	
THD (unweighted)		less than 0.05%	
<b>Line Input</b>			
Input Impedances	150mV/47k		
Frequency Response	20Hz~25KHz+0.5/-1dB		
Tone Control Range	Bass ± 6dB - Treble ± 6dB		
S/N ratio (ref 1W/8 Ohm)	75dB		
<b>Subwoofer Output</b>			
Rated Output/Impedance	150mV/10k		
Frequency Response	10Hz~300Hz+3dB		
<b>FM Tuner Section</b>			
Frequency Range	87.5~108MHz		
Sensitivity	14dB (5uV)		
Antenna Terminal	75 ohm (unbalanced)		
<b>AM Tuner Section</b>			
Frequency Range	522~1629kHz, 9kHz step		
Sensitivity	68 dB/M		
Signal to Noise Range	30 dB		
Antenna	Loop Antenna		
Power Requirement	AC230V~50Hz		
Max Power Consumption	615 Watts		
Dimensions (W x D x H)	350 x 430 x 150		
Weight	15.8kg		

# **540R V2.0 SERVICE MANUAL**

## **TABLE OF CONTENTS**

Front Panel Information	3
Remote Control	4
Remote Control Function	5
Rear Panel Information	6
Exploded Diagram	7
Exploded Diagram Parts List	8-9
PCB Interconnect Diagram	10
Decoder PCB Schematic	11-13
Decoder PCB Board Layout	14-15
Main Board – Power Supply PCB Schematic	16
Power Output & Speaker Protection	17
Main/Video Out/Speaker Connections PCB Board Layout	18
OSD PCB Schematic	19
OSD / Co-axial in/out / Connect Board B / Control Bus)	20-21
YUV PCB Schematic	22
YUV PCB Layout	23
Input / Outputs PCB Schematic	24
Display Board PCB Schematic	25
Display / Volume / AV3 PCB Layout	26
Co-axial in/out / Control Bus PCB Schematic	27
Connect Board B	28
Connect Down PCB	29-30
AC Input / Relay / Headphones PCB Schematic	31
AC Relay / Headphones PCB Layout	32
Bill of Materials	33-38
IC Pin Layout Details	39-40
Serviceable Parts List	41

# Cambridge Azur 540R V2.0 AV Receiver

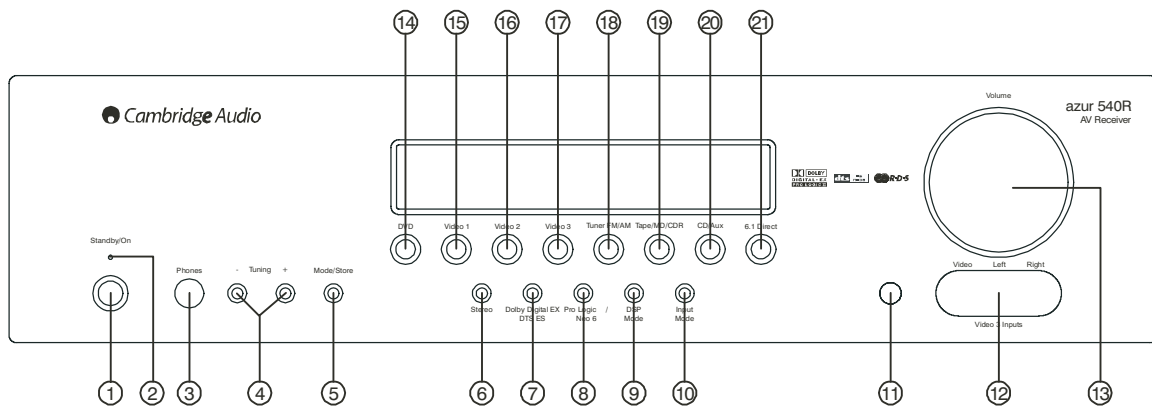

NO. & NAME	DESCRIPTION	NO. & NAME	DESCRIPTION
1. Standby/On	The power amplifier is in standby mode, indicated by the stand by indicator.	12. Video 3 Inputs	Input for VCR, Video Camera Recorder, etc. contains one video input and Analog Left and Right inputs.
2. Standby Indicator		13. Volume	Rotate this knob clockwise or counterclockwise, the master volume will be increased or decreased.
3. Phones	Jack for the stereo headphones.	14. DVD	When the coaxial /optical output terminal of a DVD player is connected to the DVD COAXIAL/OPTICAL IN terminal of this unit (5/6 rear panel), press this button to activate this function.
4. Tuning +/-	Tuner frequency or preset stations up & down.	15. Video 1	When the line output of an external player is connected to the AV 1 terminal of this unit (6/rear panel), or when the digital /optical output of another player is connected to the OPTICAL IN of this unit (6/ rear panel), press this button to activate this function.
5. Mode/Store	Press this button once to select Auto tuning mode; press it the second time to select the Manual tuning mode; press it the third time to select the Preset tuning mode, then by pressing the Tuning +/- button to select a preset station; pressing and holding this button (in any of the modes above) for 5 seconds brings up the "MEM" icon and display the next available preset for storing the current frequency.	16. Video 2	When the line output of an external player is connected to the AV 2 terminal of this unit (6/rear panel), or when the digital /optical output of another player is connected to the OPTICAL IN of this unit (6/ rear panel), press this button to activate this function.
6. Stereo	With the unit in the STEREO mode, only front left and front right speakers and Subwoofer are working.	17. Video 3	When you want to use Video 3 inputs, pressing this button to activate this function.
7. Dolby Digital EX DTS ES	Digital Surround Mode	18. Tuner FM/AM	To listen to the radio broadcast, press this button to activate this function, press again to switch waveband.
8. Dolby Pro Logic II /NEO 6	Surround modes for analog sources	19. Tape/MD/CDR	Press this button when operating the tape deck.
9. DSP Mode	Press this button to choose one of the following surround modes: THEATER, HALL, PASSTHRU, MOVIE, MUSIC and ROOM. Analog or digital	20. CD/Aux	When the coaxial output terminal of a CD player is connected to the CD COAXIAL IN terminal of this unit (5/ rear panel), press this button to activate this function.
10. Input Mode	Press this button to select input modes: ANA, OPT and COAX when using digital in.	21. 6.1 Dir ect	Press this button to select the 6.1 analogue input.
11. Remote Sensor			

# Cambridge Azur 540R V2.0 AV Receiver

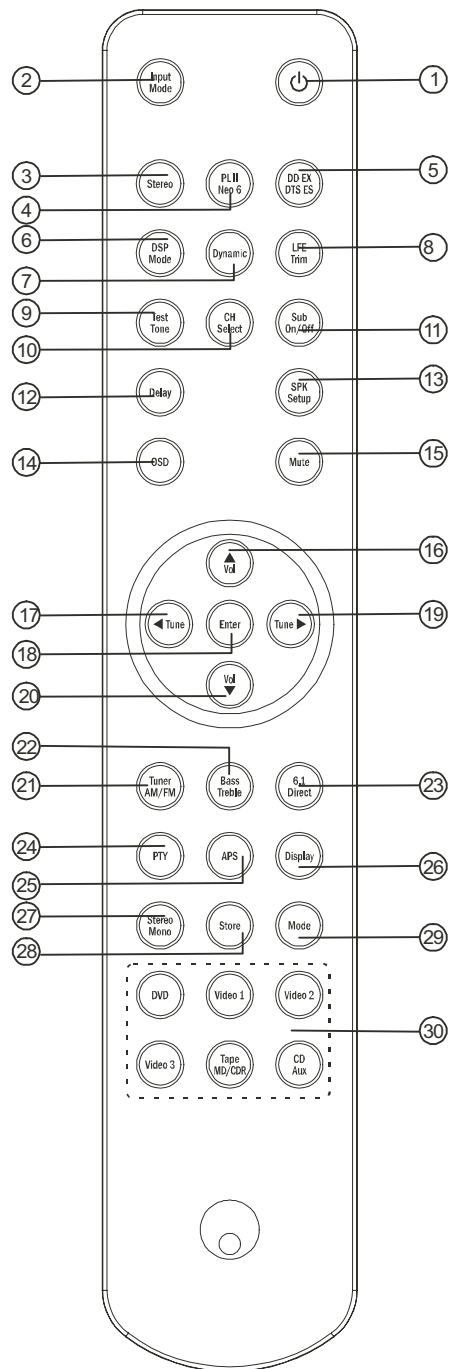

## Cambridge Audio Azur 540R V2.0 AV Receiver

NO. & NAME	DESCRIPTION	NO. & NAME	DESCRIPTION
1. Power On/Standby	Press this button to turn this unit on or off.	16. /Volume up	- Direction button. - Press these buttons to increase the volume.
2. Input Mode	Press it to select: Digital or Analog mode.	17. /Tune down	- Direction button. - Tuner frequency down.
3. Stereo	With this unit in STEREO mode, only Front Left & Front Right speakers and Woofer have output.	18. Enter	Press this button when you want to enter the OSD setup menu.
4. PL II / NEO 6	When receiving Analog/digital PCM signals.	19. /Tune up	- Direction button. - Tuner frequency up.
5. DD EX /DTS ES	For digital surround signals	20. /Volume down	- Direction button. - Press these buttons to decrease the volume.
6. DSP MODE	Press this button to choose one of the following surround modes: THEATER, HALL, PASSTHRU, MOVIE, MUSIC and ROOM.	21. Tuner AM/FM	Press this button to alternate between FM and AM.
7. Dynamic	Press this button repeatedly to reach your desired compression dynamic range.	22. Bass/Treble	Press this button for Bass /Treble adjustment, then press Vol up and Vol down to adjust the level.
8. LFE Trim	Under the Pro Logic 5.1CH or DTS 5.1CH mode, press this button and adjust the volume to set the Low Frequency output level	23. 6.1 Direct	Press this button to select the 6.1 analogue input.
9. Test Tone	To balance speakers in Dolby Digital or Dolby Pro Logic mode.	24. PTY	In FM state, press this button, the current program type appears on the display, using Tuning +/- to select the program type you desire.
10. CH Select	Select channels by pushing this button, then use volume key to balance speakers	25. APS	Allocates and memorizes radio stations automatically.
11. Sub On/Off	Press this button to turn on/off the output of subwoofer.	26. Display	With RDS, press this button repeatedly to have PS (program name) or CT (current time).
12. Delay	Press this button to set the delay time for the Dolby digital/Dolby Pro Logic modes.	27. Stereo / Mono	Press this button to alternate between Stereo and Mono mode when listen to FM broadcast.
13. SPK Setup	Under PRO LOGIC II or Digital state, it can change the desired Speaker Setting shown on the display.	28. Store	Pressing this button to store the current frequency.
14. OSD	Press this button to access the AV Receiver configuration settings by using the OSD menus.	29. Mode	Pressing this button to select Auto /Manual tuning mode and Preset mode.
15. Mute	Press this button to mute the sound, push again to cancel the mute function.	30. Input Selector	Press the corresponding button according to your desired selection.

# Cambridge Azur 540R V2.0 AV Receiver

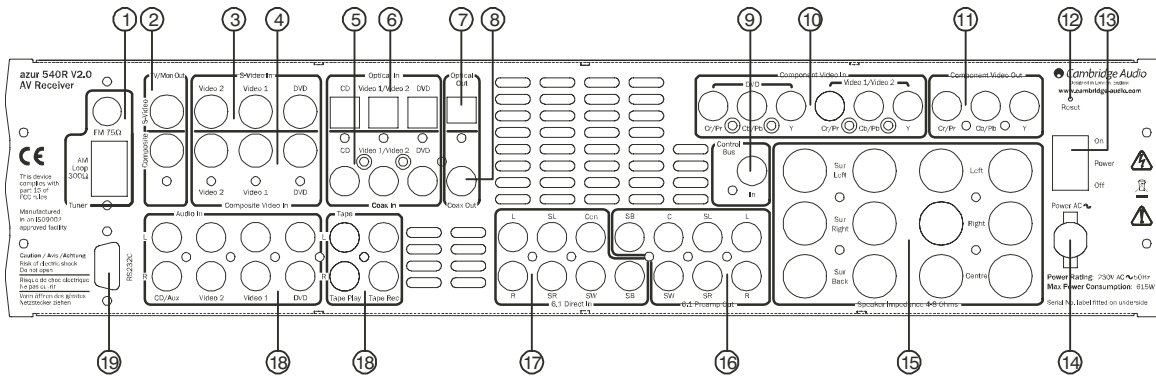

1. FM / AM antenna
2. TV /Mon Out  
S-V ideo out ..... using the S-Video cable to connect this terminal to the corresponding terminal on the TV set.  
Composite Video out ..... using the RCA cable to connect this terminal to the corresponding terminal on the TV set.
3. S-V ideo in  
Video 1 /Video 2 ..... connect to the corresponding output terminals of a VCR.  
DVD ..... connect to the corresponding line output terminal of a DVD player.
4. Composite Video in  
Video 1 /Video 2 ..... connect to the corresponding output terminals of a VCR.  
DVD ..... connect to the corresponding line output terminal of a DVD player.
5. Coax in  
CD ..... digital audio input to the digital output of a CD player.  
Video 1 /Video 2 ..... digital audio input to the digital output of a VCR.  
DVD ..... digital audio input to the digital output of a DVD player.
6. Optical in  
CD ..... optical audio input to the optical output of a CD player.  
Video 1 /Video 2 ..... optical audio input to the optical output of a VCR.  
DVD ..... optical audio input to the optical output of a DVD player.
7. Optical Out ..... digital audio output to the digital optical input of another amplifier, external recording device or decoder.
8. Coax Out ..... digital audio output to the digital coaxial input of another amplifier, external recording device or decoder.
9. Contr ol Bus terminal ..... This terminal is used for our system controlling.
10. Component Video In  
DVD ..... connect to the Cr Cb Y terminal of a DVD player.  
Video 1 /Video 2 ..... connect to the Cr Cb Y terminal of external players.
11. Component Video Out ..... connect to the Cr Cb Y terminal on the TV set.
12. R eset ..... this is used to reset the whole system (including the memories set).
13. Power On / off ..... pressing this switch to turn on /off this unit.
14. Power AC ..... connect to the AC socket.
15. Speaker terminals ..... connect to the external speakers with 4-8 impedance.
16. 6.1 Pr eamp Out ..... connect to the 7 channel input terminals of another amplifier.
17. 6.1 Direct In ..... connect to the 7 channel output terminals of another player.
18. Audio In  
Tape Rec ..... connect to the line input terminals on the Tape Deck.  
Tape Play ..... connect to the line output terminals on the Tape Deck.  
DVD ..... connect to the line output terminal of a DVD player.  
Video 1 /Video 2 ..... connect to the line output terminals of external players.  
CD / Aux ..... connect to the line output terminal of a CD player.
19. R S232C ..... This terminal is used for software upgrade.

# Cambridge Audio Azur 540R V2.0 AV Receiver

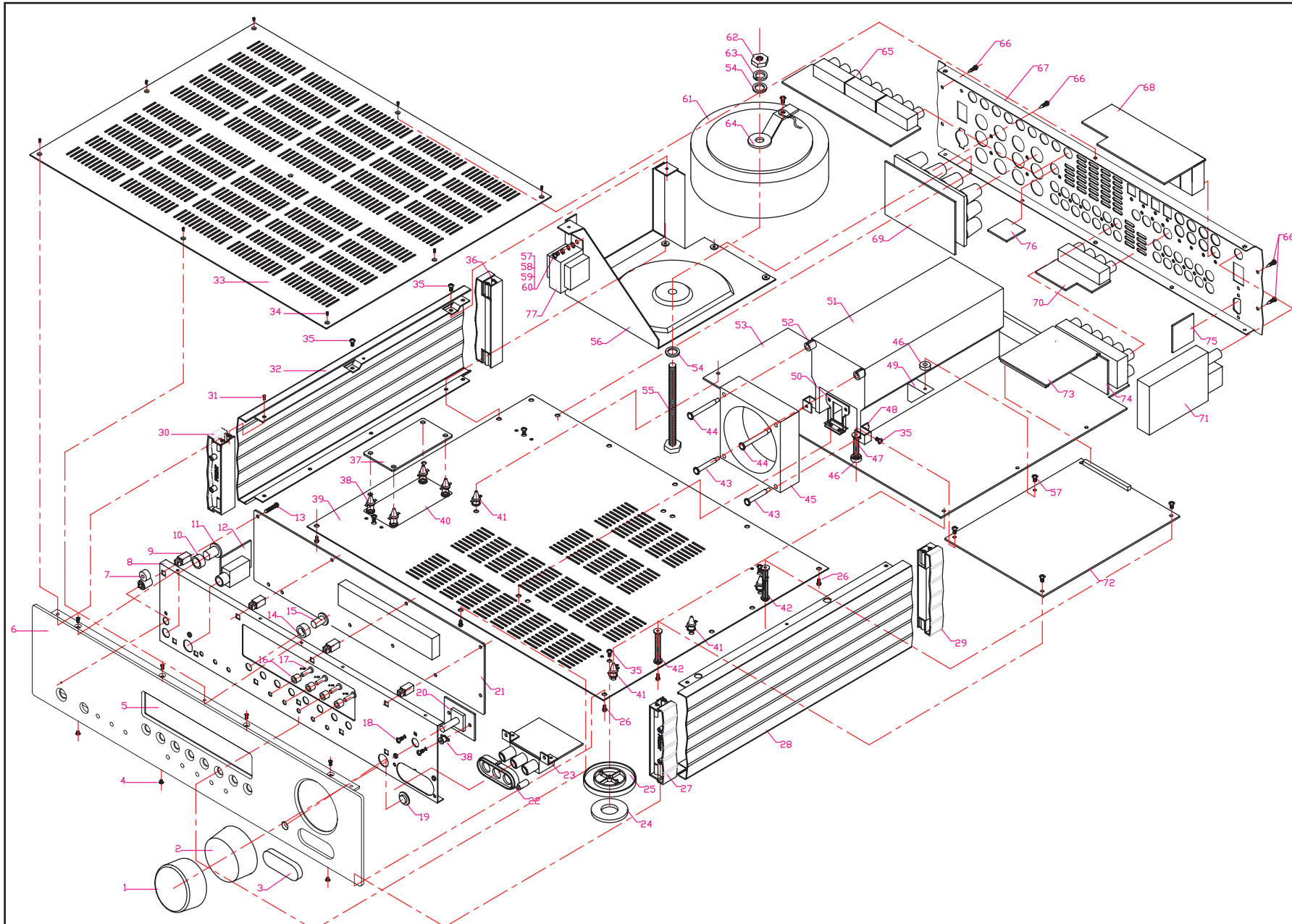

To enhance viewing, please print to A3

**Exploded Diagram**

## Cambridge Audio Azur 540R V2 AV Receiver

Sel.	Part NO.	Description	Qty.	Remark
1	6531 1010 0011	VOLUMN KNOB AL SKIN	1	
2	7331 1040 0000	AMP VOLUMN KNOB	1	
3	7931 1100 0091	AV3 cover	1	
4	5014 3006 0000	SCREW BTB 3.0X6	8	
5	7431 1010 0080	DISPLAY LENS	1	
6	6031 1010 0221	AL PANEL	1	
7	7431 1030 0000	AMP LIGHT GUIDE	1	
8	5331 1010 0000	SCALEBOARD	1	
9	7931 1020 0000	PCB COLUMN	10	
10	7631 1010 0000	MR CONTROL BOX BUTTON CUSHION	1	
11	7331 1010 0011	MR CONTROL BOX BUTTON	1	
12	0554 0117 1001	PHONE PCB	1	
13	5011 3014 1000	SCREW BTB3.0X14	10	
14	7631 1020 0000	7MM TAC SWITCH BUTTON CUSHION	8	
15	7331 1020 0011	7MM TAC SWITCH BUTTON	8	
16	7631 1030 0000	4MM TAC SWITCH BUTTON CUSHION	8	
17	7331 1030 0011	4MM TAC SWITCH BUTTON	8	
18	5011 3004 1000	SCREW BTB 3.0X4	15	
19	7431 1020 0000	IR LENS	1	
20	0054 1030 0004	VOLUMN PCB	1	
21	0054 1030 0004	DISPLAY PCB	1	
22	7931 1010 0011	DECORATION	1	
23	0054 1083 2005	AV3 PCB	1	
24	7931 1060 0001	FOOT PAD	4	
25	7931 1050 0011	FOOT	4	
26	5012 3008 1000	BM 3.0X8	4	
27	7531 1040 0000	540R front support right assy	1	
28	6431 1020 0011	SIDE COVER(RIGHT)	1	
29	7531 1050 0000	540R rear support right assy	1	
30	7531 1020 0000	540R front support left assy	1	
31	5014 2608 0000	SCREW BTB 2.6X8	8	
32	6431 1010 0011	SIDE COVER(LEFT)	1	
33	6131 1010 0011	TOP COVER	1	
34	5018 2608 1000	SCREW BM 2.6X8	8	
35	5011 3006 1000	SCREW BTB 3.0X6	46	
36	7531 1030 0000	540R rear support left assy	1	
37	0054 0110 1001	FUSE PCB	1	
38	8711 0000 0000	CBS-10SN H=10	4	
39	6231 1010 0011	BOTTOM COVER	1	
40	7708 0400 5010	PCB PVC	1	
41	8710 6000 0000	CBS-6SN H=6	7	
42	8734 0000 0000	KDDT-382 H=40	2	
43	5931 1030 0000	BOLT L=24	2	
44	5931 1010 0000	BOLT L=32	2	
45	9102 2513 3231	FAN	1	
46	7931 1070 0000	WASH (D10xD4xH3)	2	
47	8713 0000 0000	CBS-30SN H=30	1	



## Cambridge Audio Azur 540R V2 AV Receiver

48	5331 1030 0000	FAN BRACKET	2	
49	5331 1060 0000	DECODE PCB BRACKET	1	
50	5331 1020 0000	HEATSINK BRACKET	2	
51	5131 1010 0000	HEATSINK	1	
52	5931 1020 0000	HEATSINK COLUMN	2	
53	0054 1003 2005	MAIN PCB	1	
54	5040 8000 0001	WASH $\phi$ 8	2	
55	5015 8080 0040	BOLT	1	
56	5331 1050 0011	TRANSFORMER BRACKET	1	
57	5011 3008 1000	SCREW BTB 3.0X8	24	
58	5020 3006 0360	NUT $\phi$ 3.2	2	
59	5040 0300 0000	SPRING WASHER $\phi$ 3.0	2	
60	5030 0800 3210	WASH $\phi$ 3.2 x $\phi$ 8.0 x 1.0mm	2	
61	4000 1015 0000	TRANSFORMER	1	
62	5020 8012 0201	NUT $\phi$ 8	1	
63	5040 3000 0001	SPRING WASHER M3	1	
64	5931 1050 0000	TEMPERATURE AL	1	
65	0054 1140 1002	YUV PCB	1	
66	5013 3008 000	SCREW PA 3.0x8	42	
67	6331 1030 0111	BACK COVER	1	
68	0054 1241 1006	OSD PCB	1	
69	0054 1233 2005	OUTPUT PCB	1	
70	0054 1381 2006	COAX PCB	1	
71	9800 0003 0001	TUNER BOX	1	
72	0054 1280 1005	DECODE PCB	1	
73	0054 1321 3006	CONNECT PCB(T)	1	
74	0054 1321 0003	CONNECT PCB(B)	1	
75	0054 9223 0000	S232 PCB	1	
76	0054 1221 4006	CONTROL PCB	1	
77	4000 1355 1000	STB STRANSFORMER	1	

# Cambridge Audio Azur 540R V2 AV Receiver

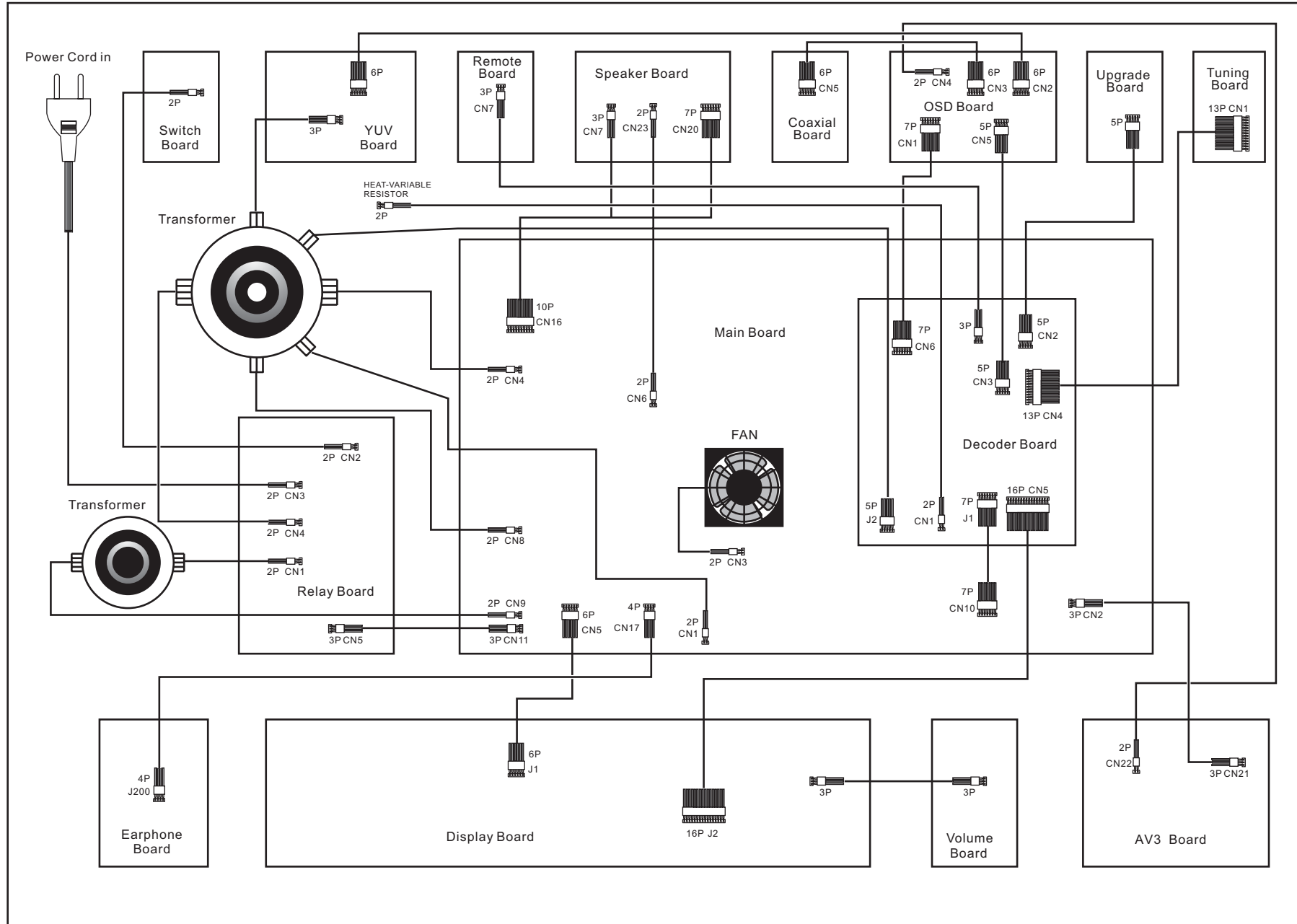

PCB Interconnect Diagram

# Cambridge Audio Azur 540R V2.0 AV Receiver

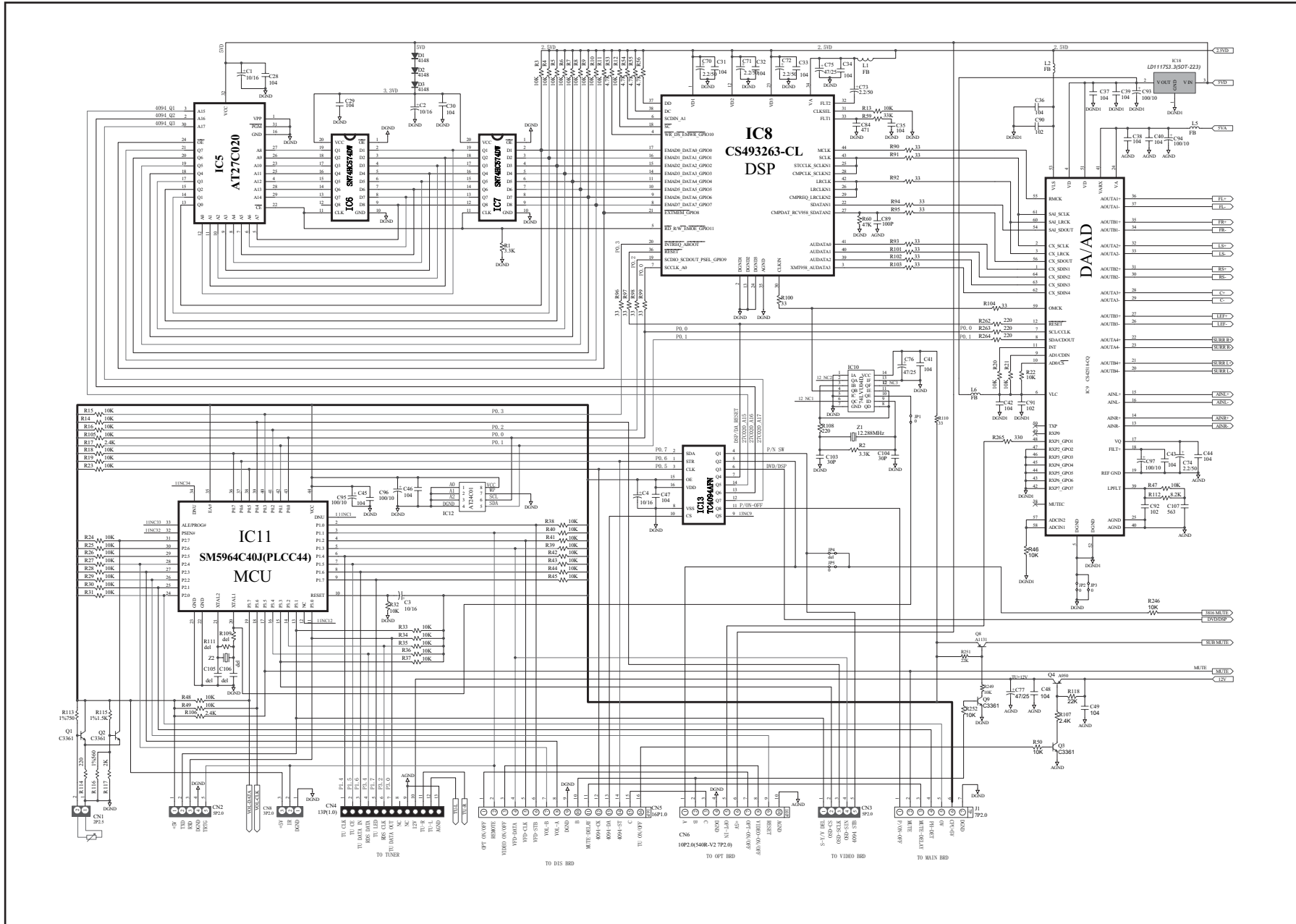

To enhance viewing, please print to A3

Decoder PCB Schematic (1 of 3)

# Cambridge Audio Azur 540R V2.0 AV Receiver

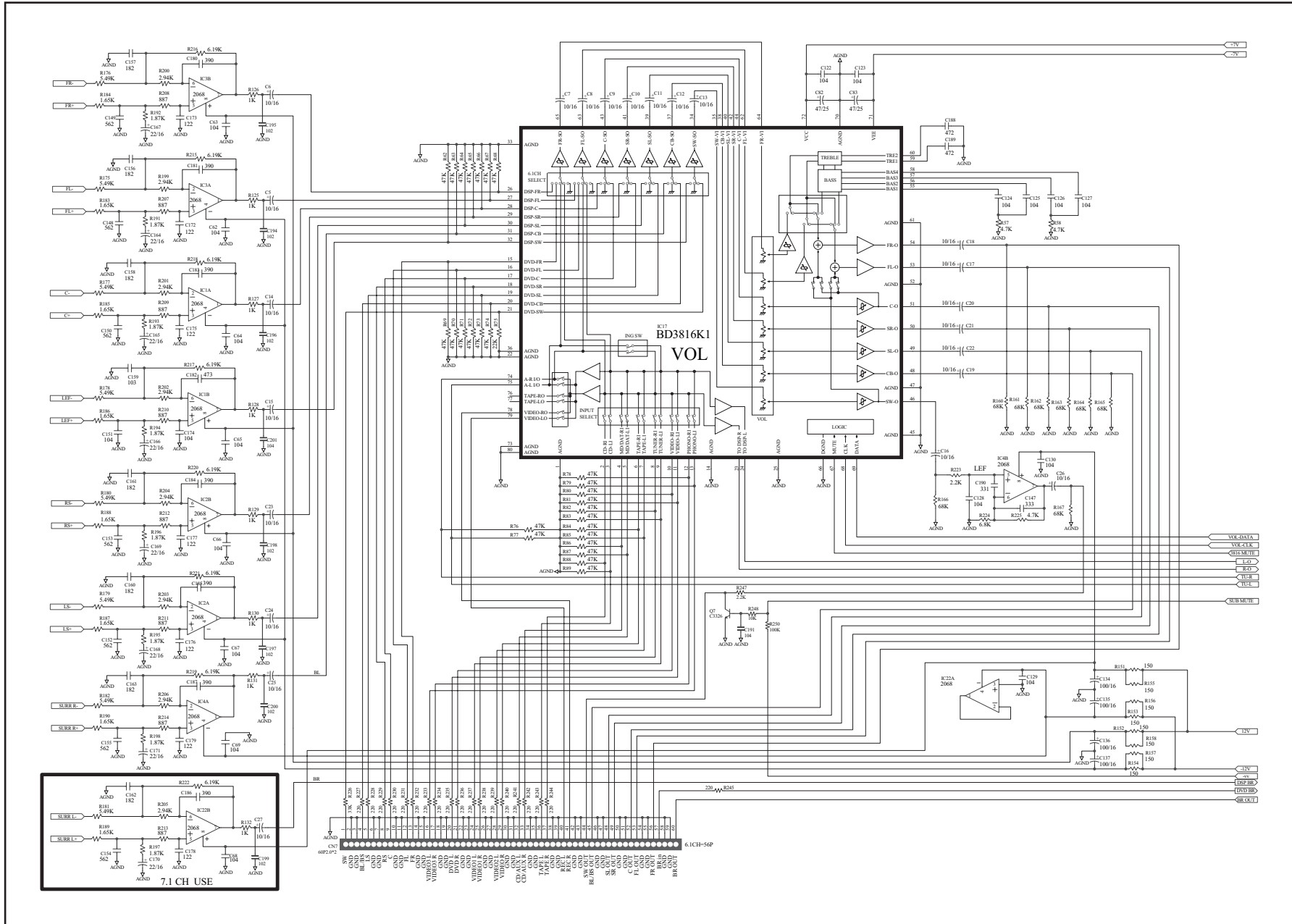

To enhance viewing, please print to A3

# Cambridge Audio Azur 540R V2.0 AV Receiver

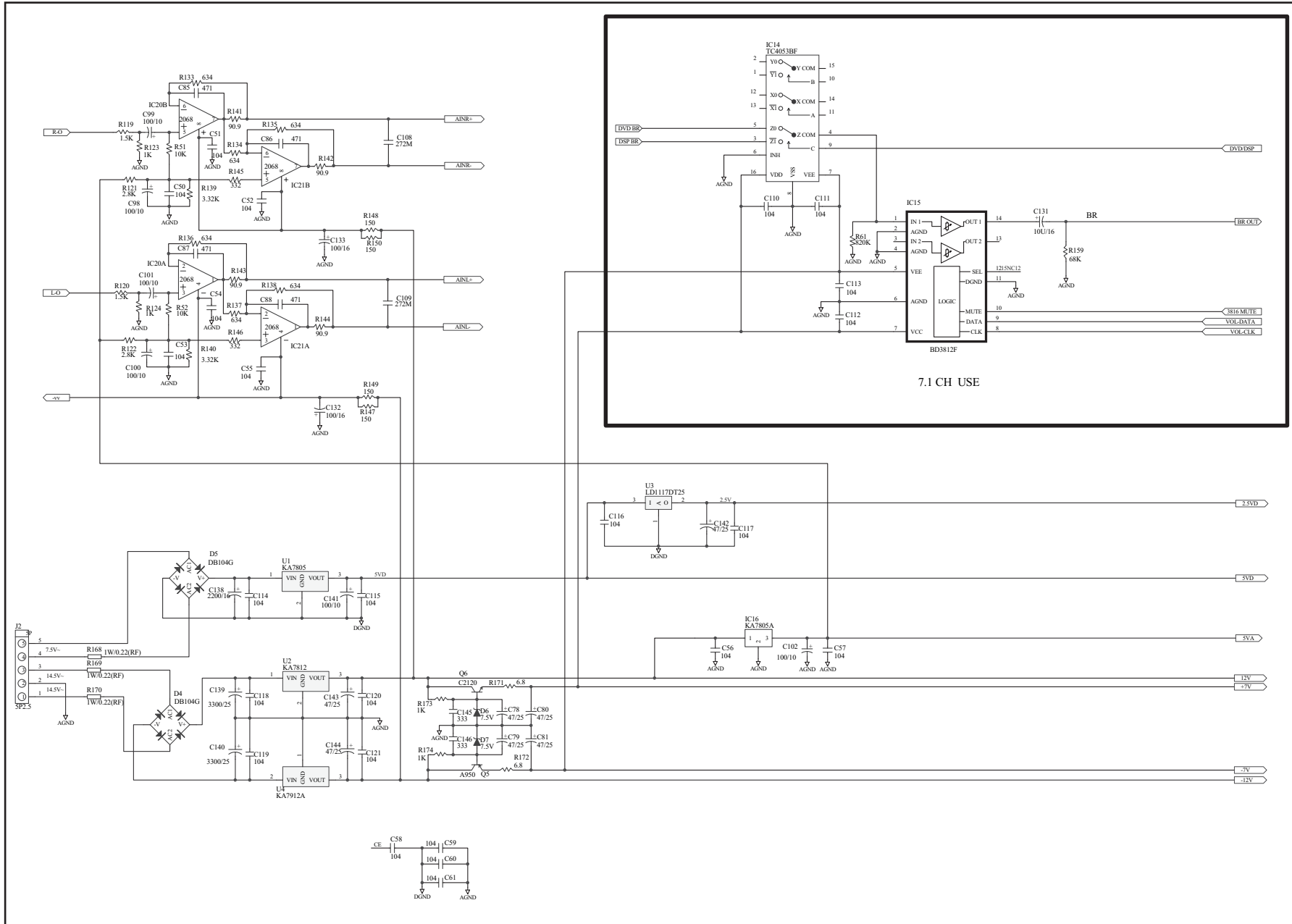

To enhance viewing, please print to A3

# Cambridge Audio Azur 540R V2.0 AV Receiver

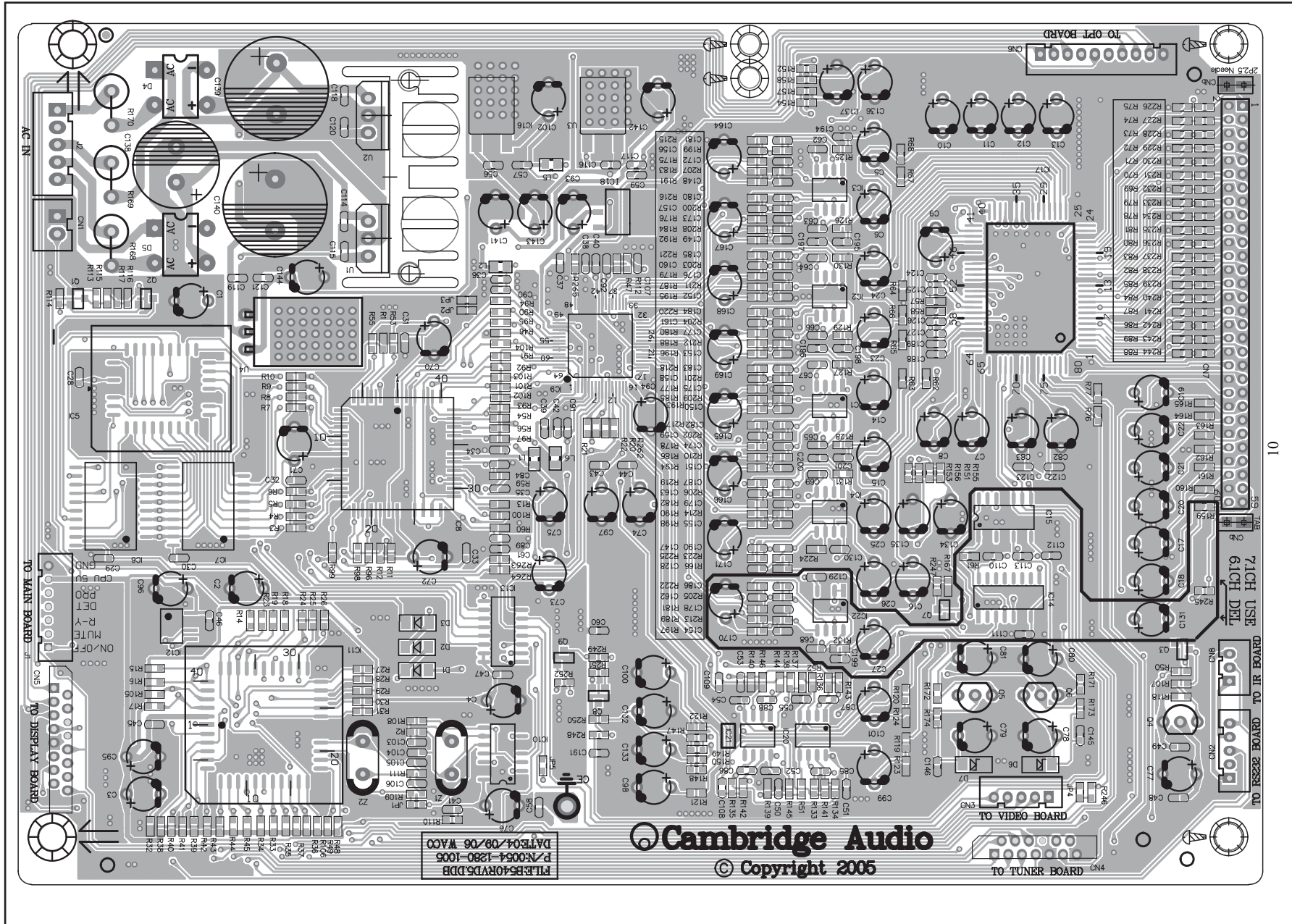

To enhance viewing, please print to A3

## Decoder PCB Board Layout (1 of 2)

# Cambridge Audio Azur 540R V2.0 AV Receiver

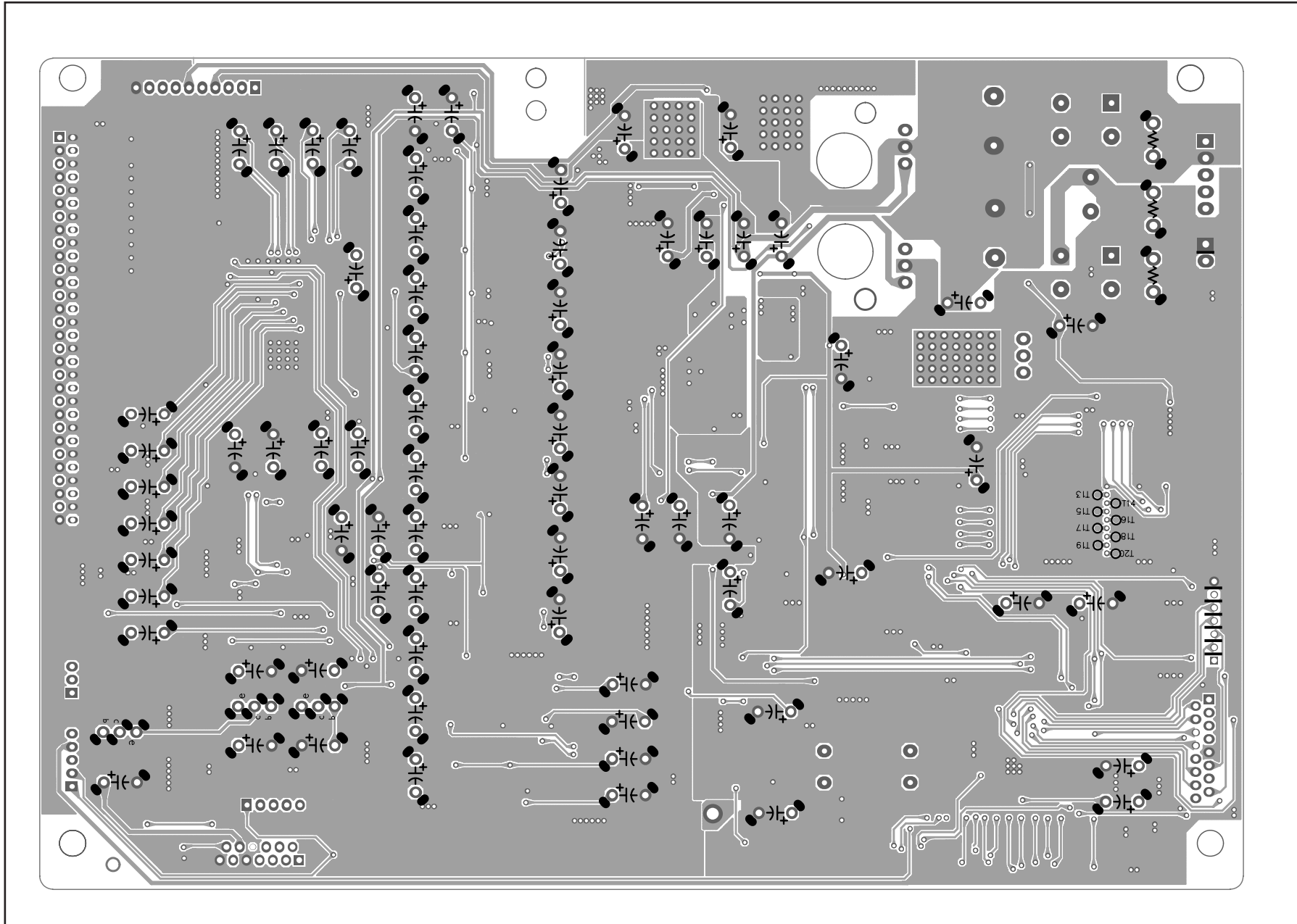

To enhance viewing, please print to A3

## Decoder PCB Board Layout (2 of 2)

# Cambridge Audio Azur 540R V2.0 AV Receiver

**⚠ INDICATES SAFETY CRITICAL COMPONENTS. TO REDUCE THE RISK OF ELECTRIC SHOCK LEAKAGE CURRENT OR RESISTANCE MEASUREMENTS SHALL BE CARRIED OUT (EXPOSED PARTS ARE ACCEPTABLY INSULATED FROM THE SUPPLY CIRCUIT) BEFORE THE APPLIANCE RETURNED TO THE CUSTOMER.**

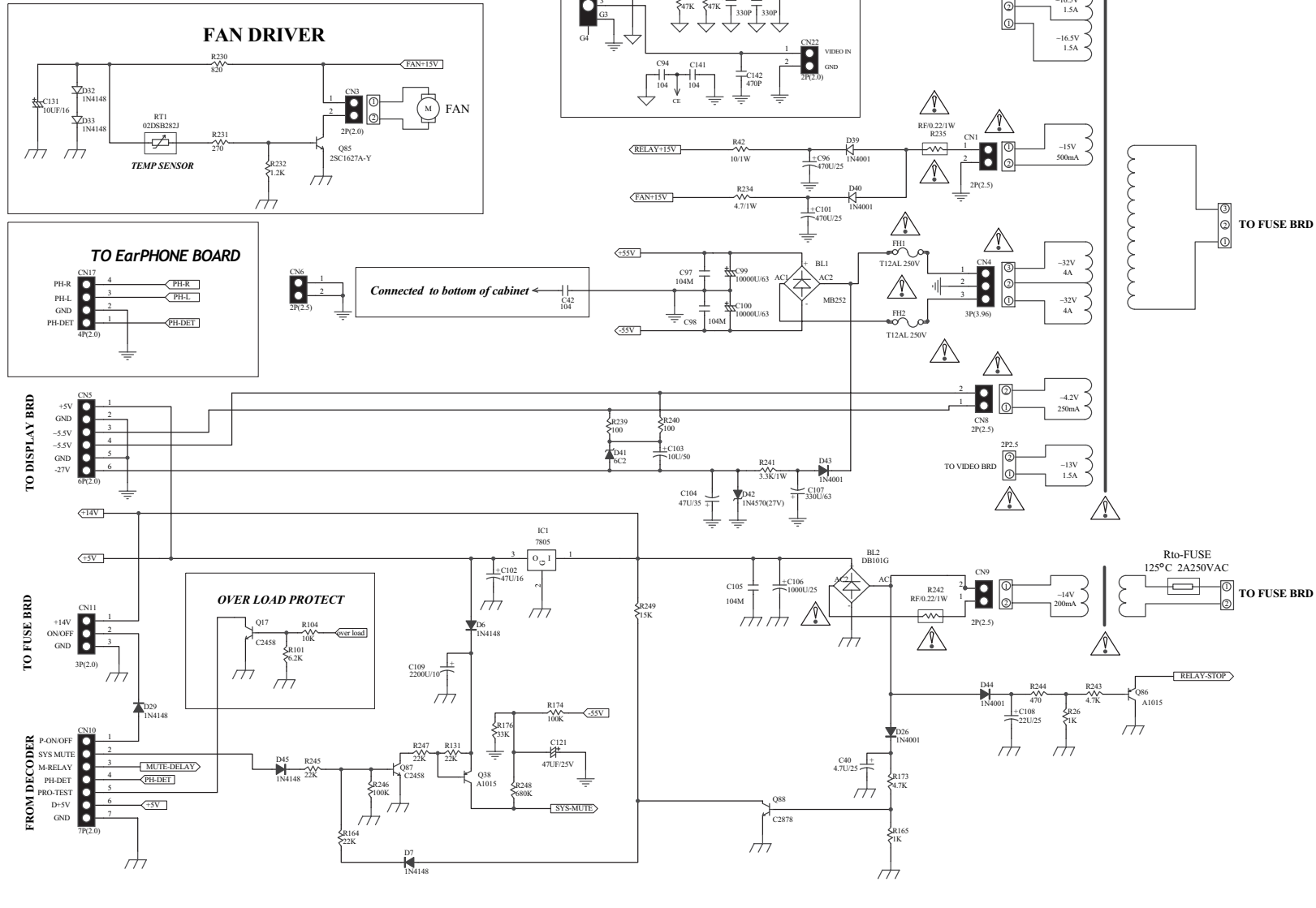

To enhance viewing, please print to A3

## Main Board - Power Supply PCB Schematic



# Cambridge Audio Azur 540R V2.0 AV Receiver

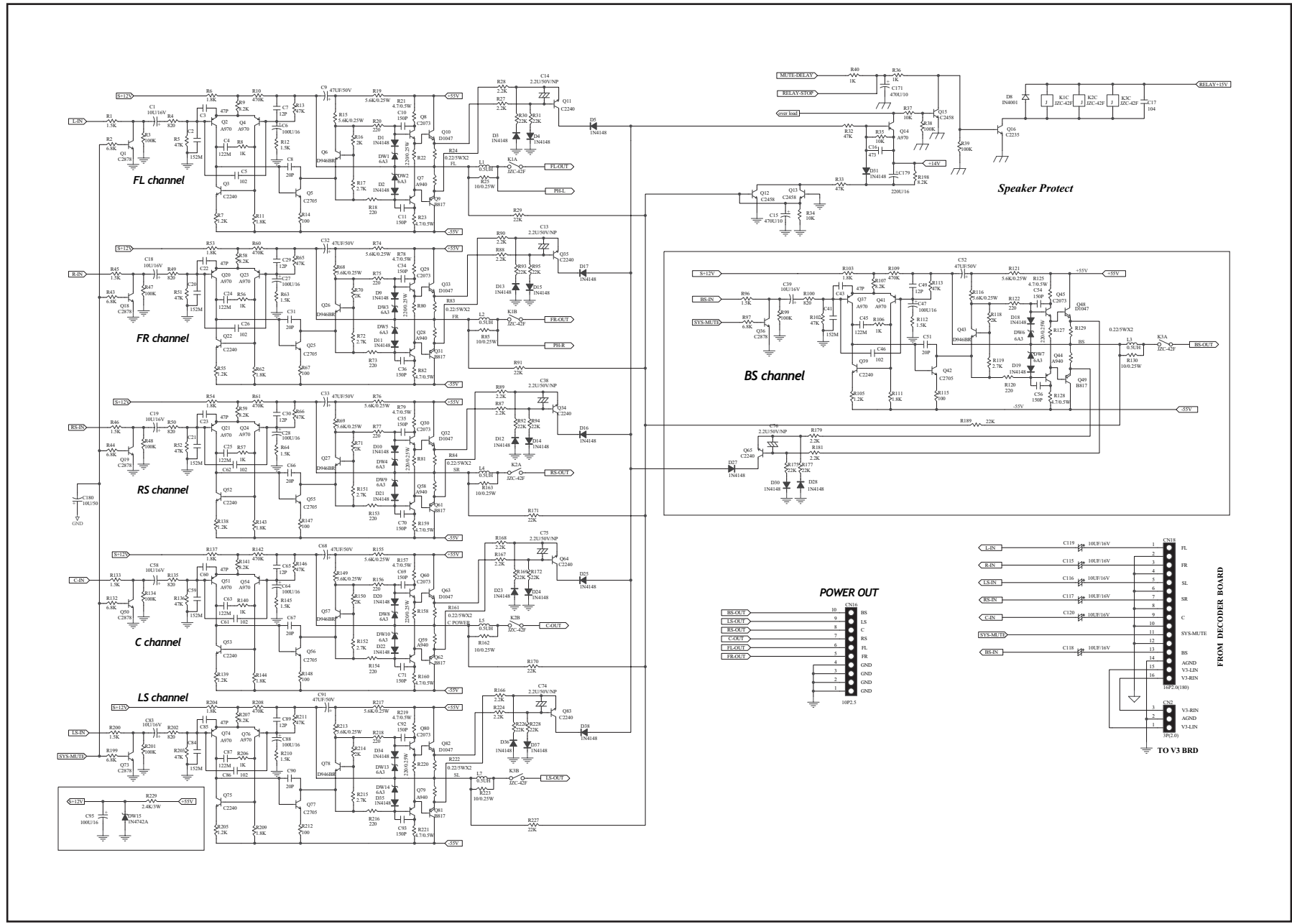

To enhance viewing, please print to A3

## Main Board - Power Output & Speaker Protection PCB Schematic



# Cambridge Audio Azur 540R V2.0 AV Receiver

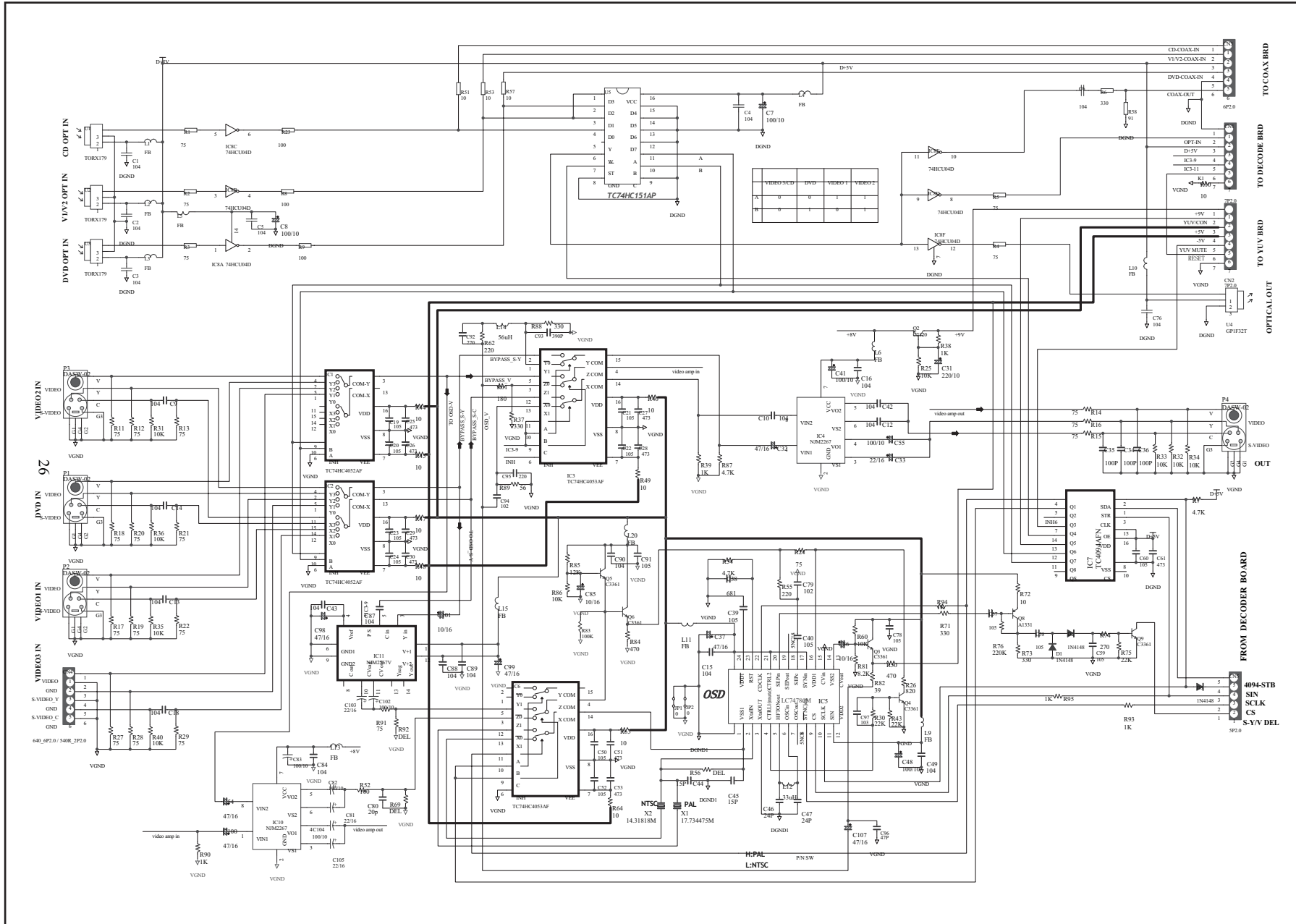

To enhance viewing, please print to A3

## OSD PCB Schematic

# Cambridge Audio Azur 540R V2.0 AV Receiver

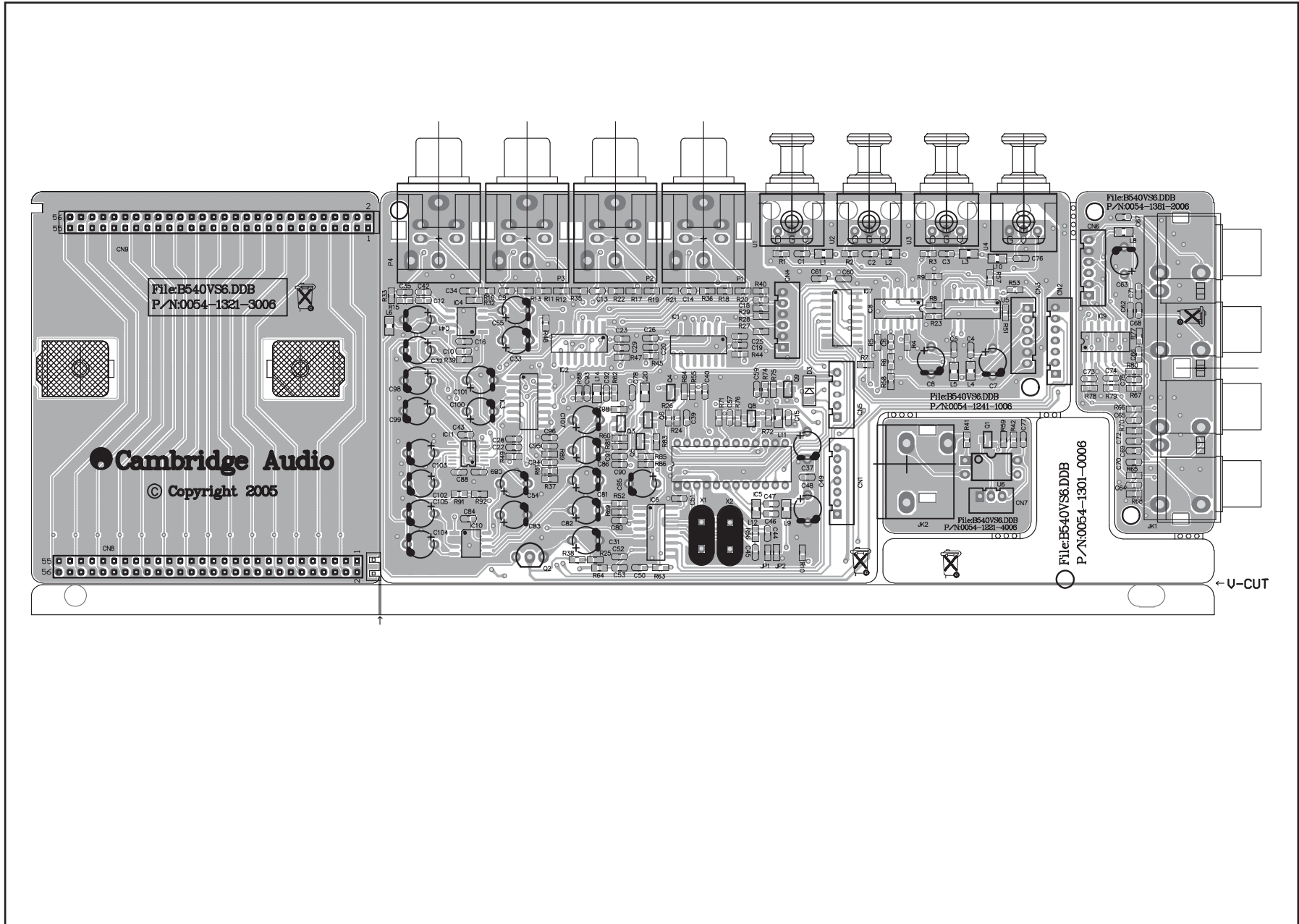

To enhance viewing, please print to A3

**OSD / Co-axial In/Out / Connect Board B / Control Bus PCB Board Layout**



# Cambridge Audio Azur 540R V2.0 AV Receiver

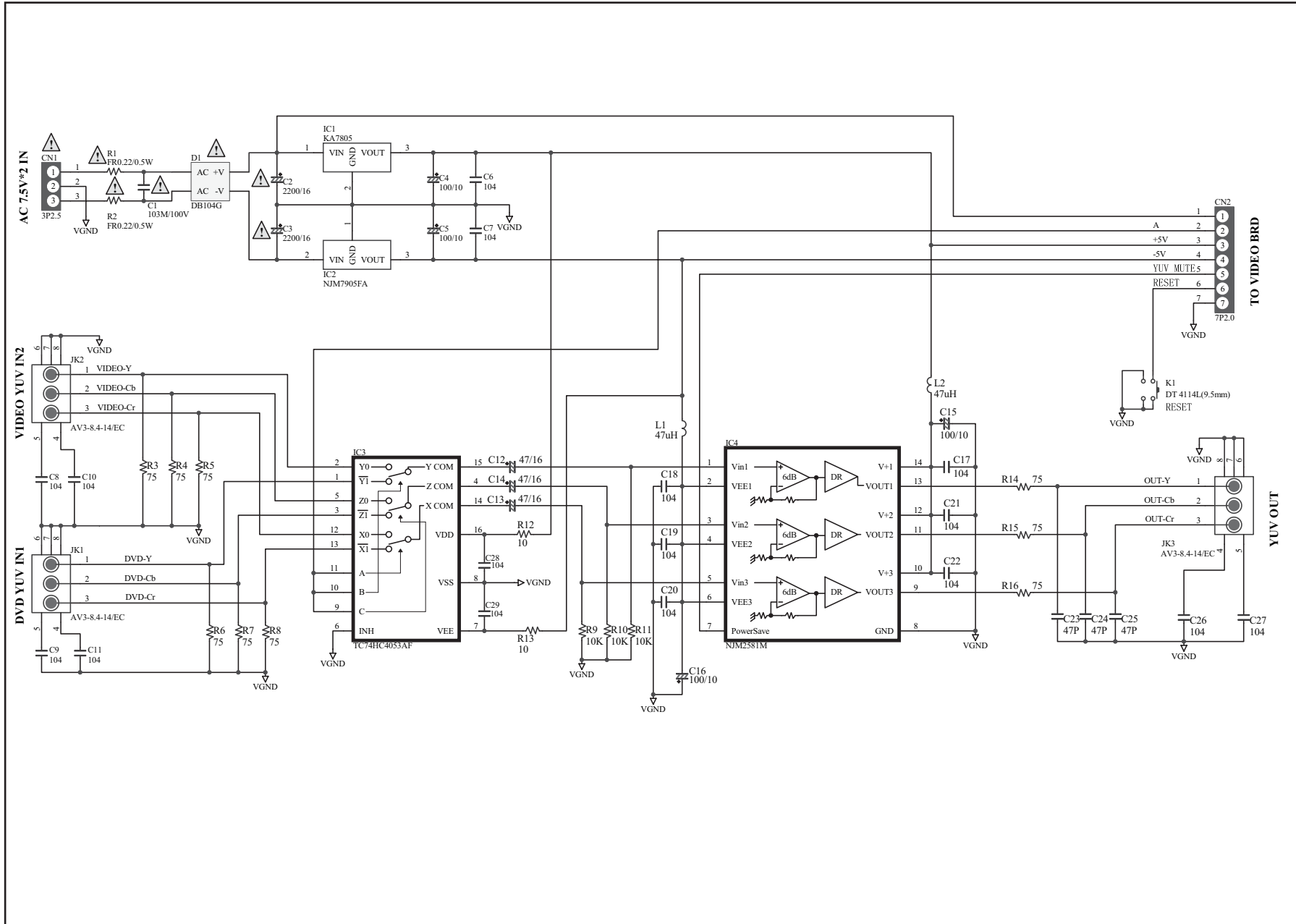

To enhance viewing, please print to A3

## YUV PCB Schematic

# Cambridge Audio Azur 540R V2.0 AV Receiver

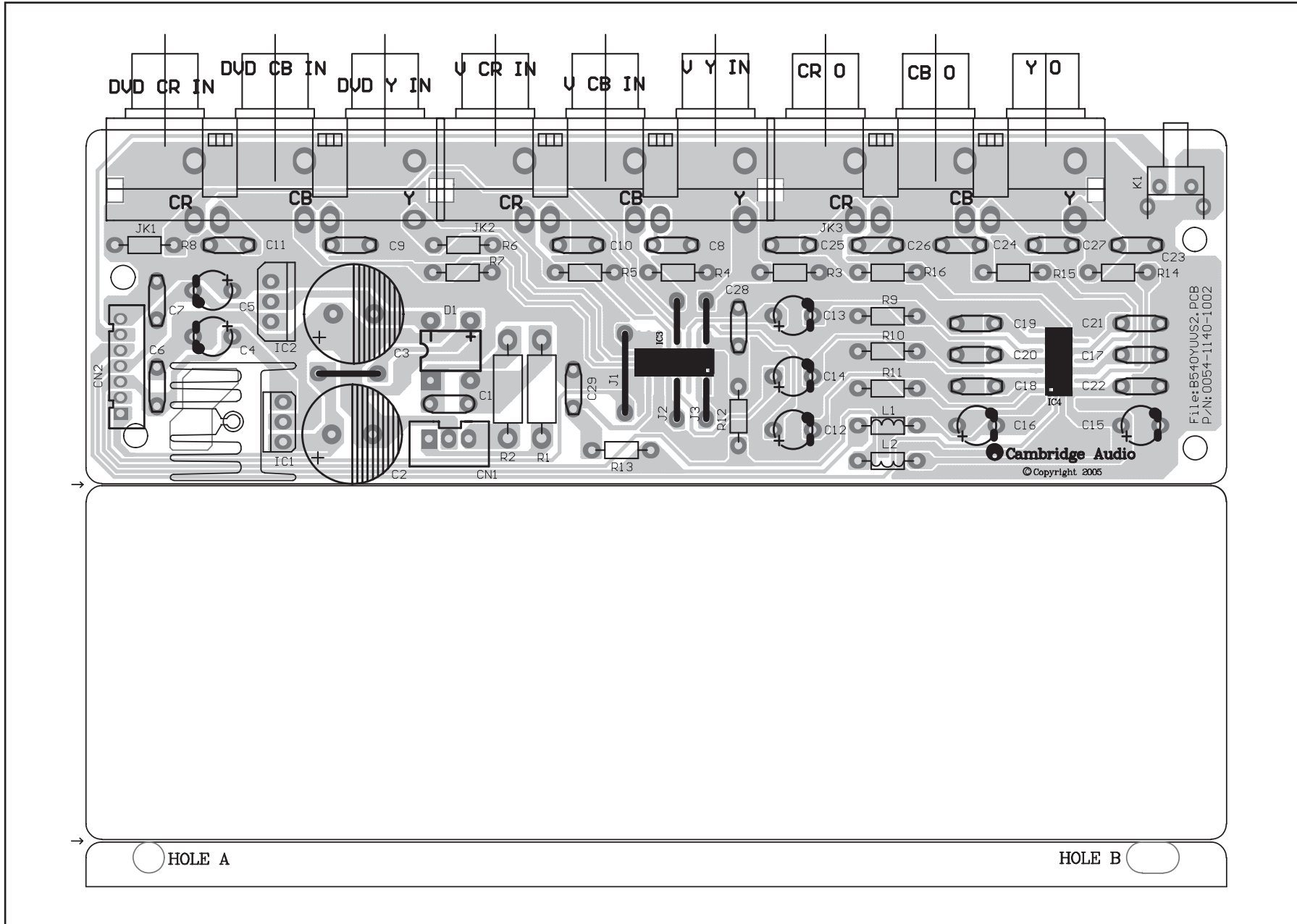

To enhance viewing, please print to A3

## YUV PCB Board Layout





# Cambridge Audio Azur 540R V2.0 AV Receiver

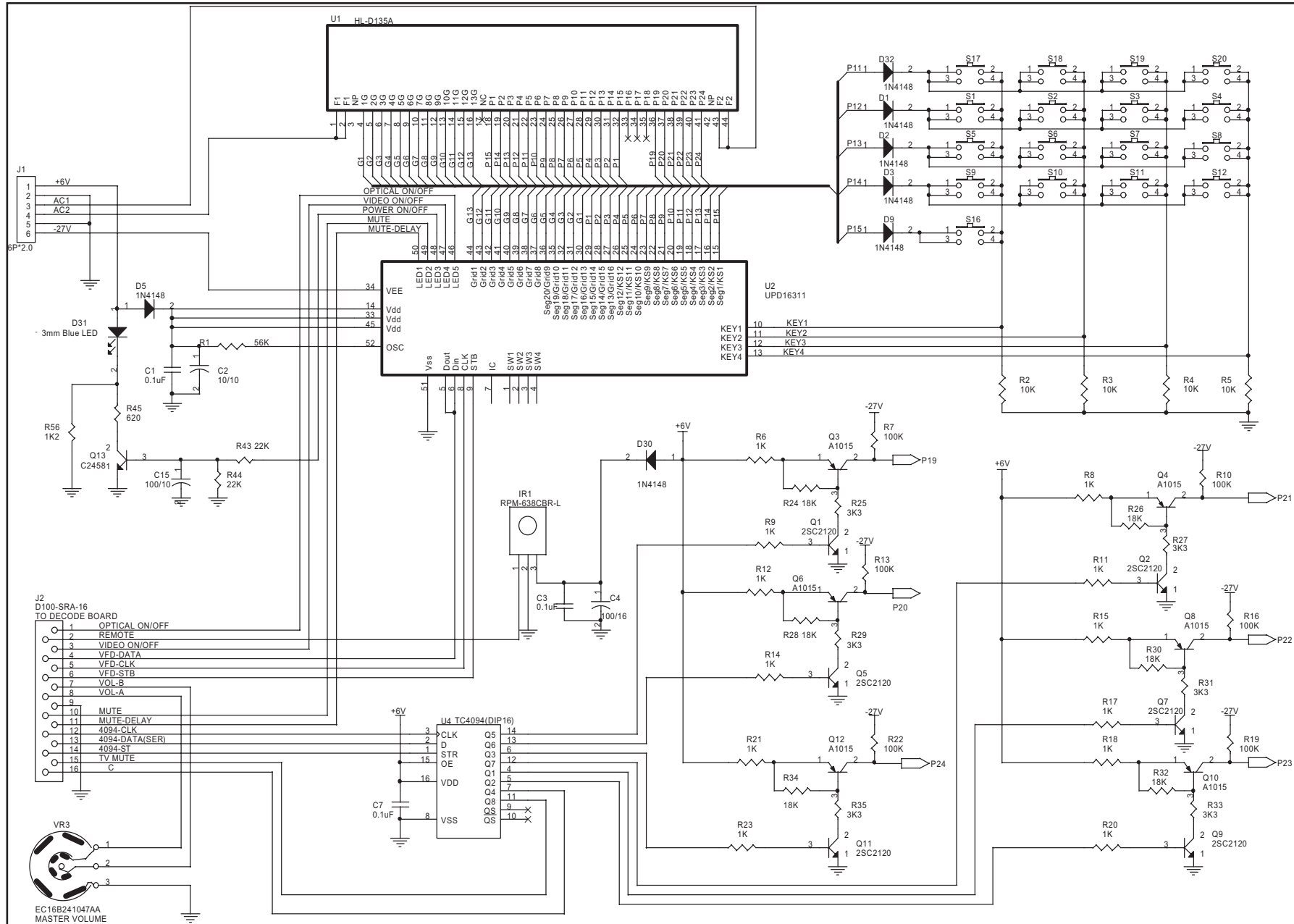

To enhance viewing, please print to A3

## Display Board PCB Schematic

# Cambridge Audio Azur 540R V2.0 AV Receiver

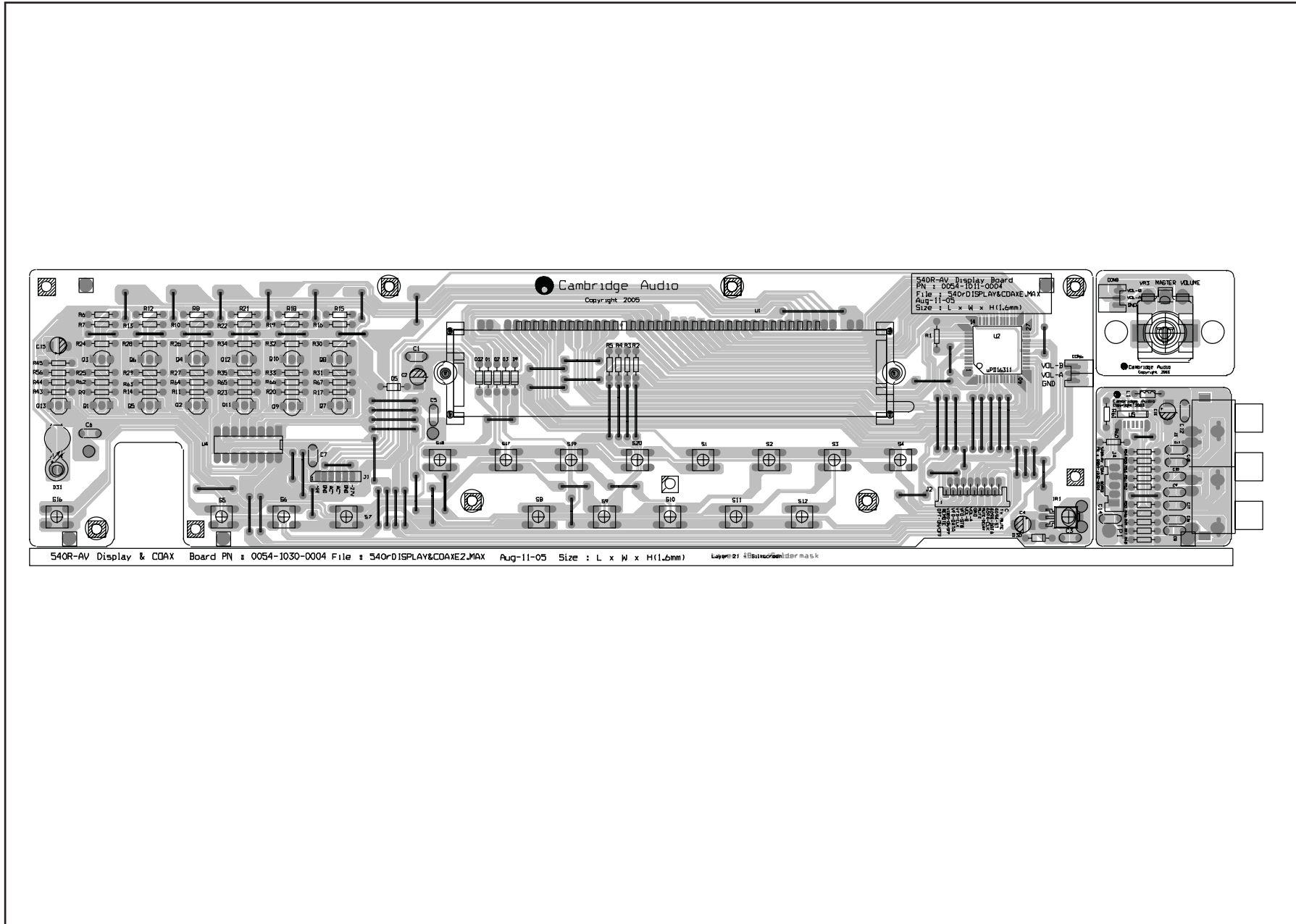

To enhance viewing, please print to A3

Display / Volume / AV3 PCB Layout

# Cambridge Audio Azur 540R V2.0 AV Receiver

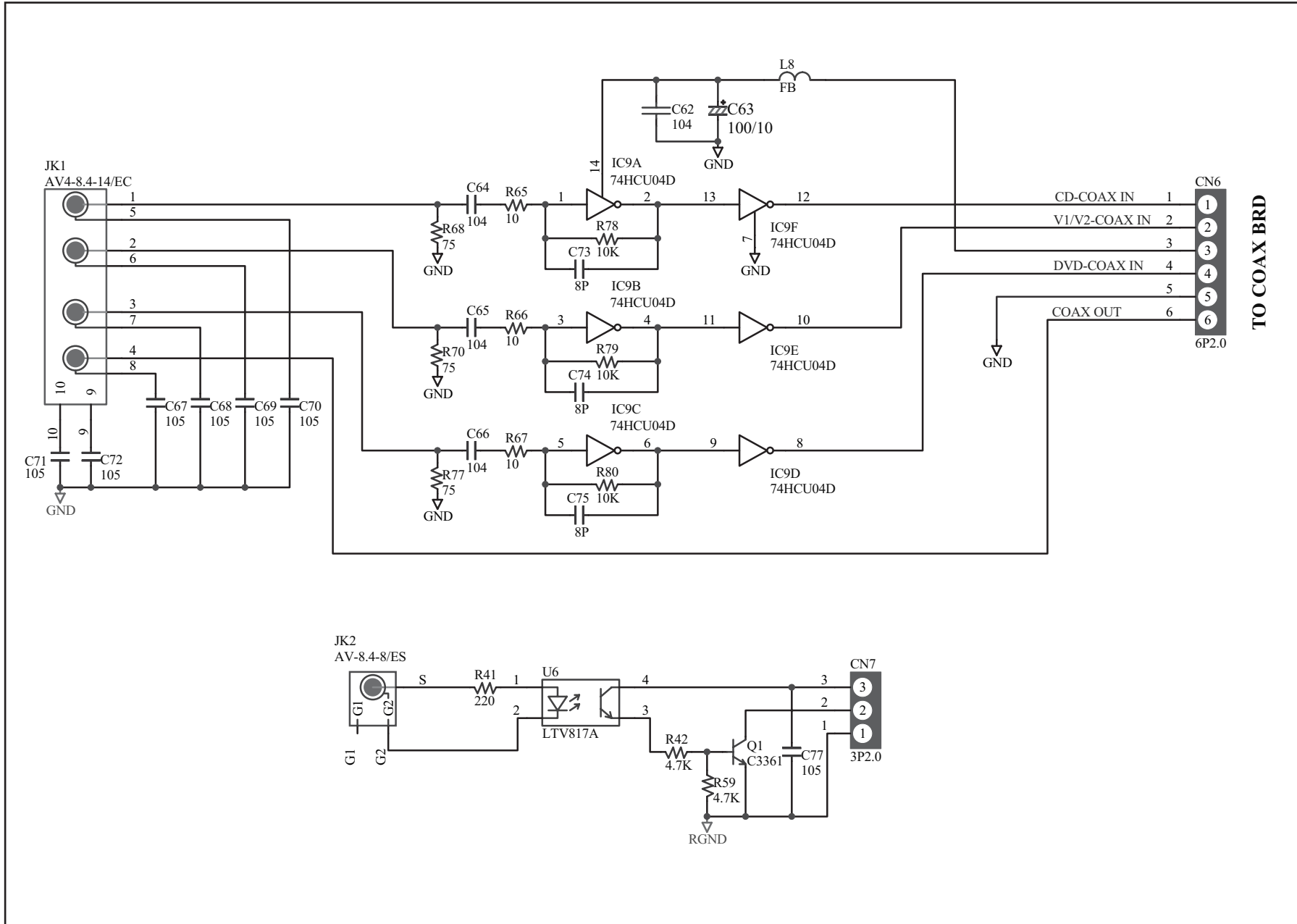

To enhance viewing, please print to A3

## Co-axial in/out / Control Bus PCB Schematic

# Cambridge Audio Azur 540R V2.0 AV Receiver

## CONNECT BOARD B

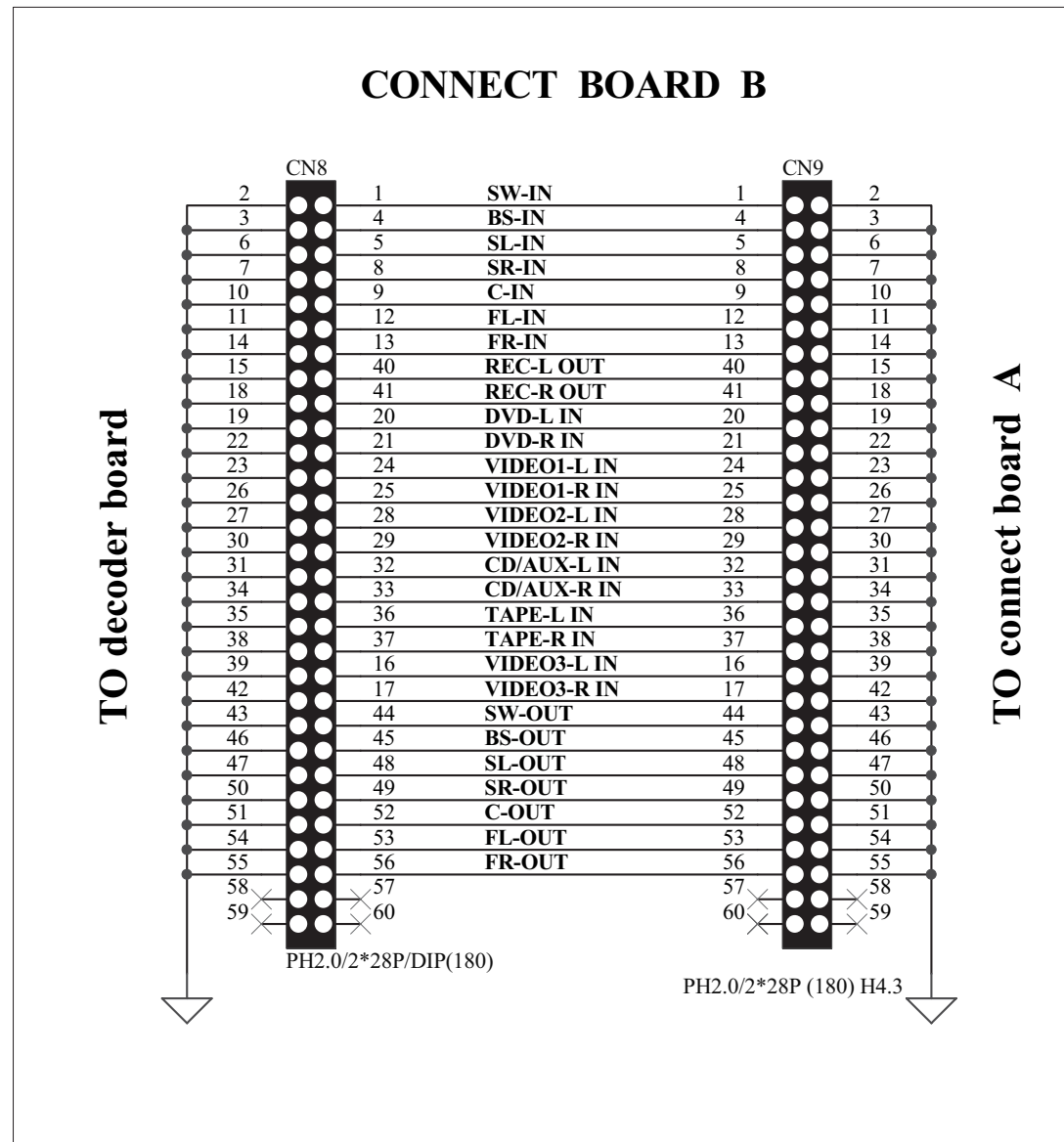

# Cambridge Audio Azur 540R V2.0 AV Receiver

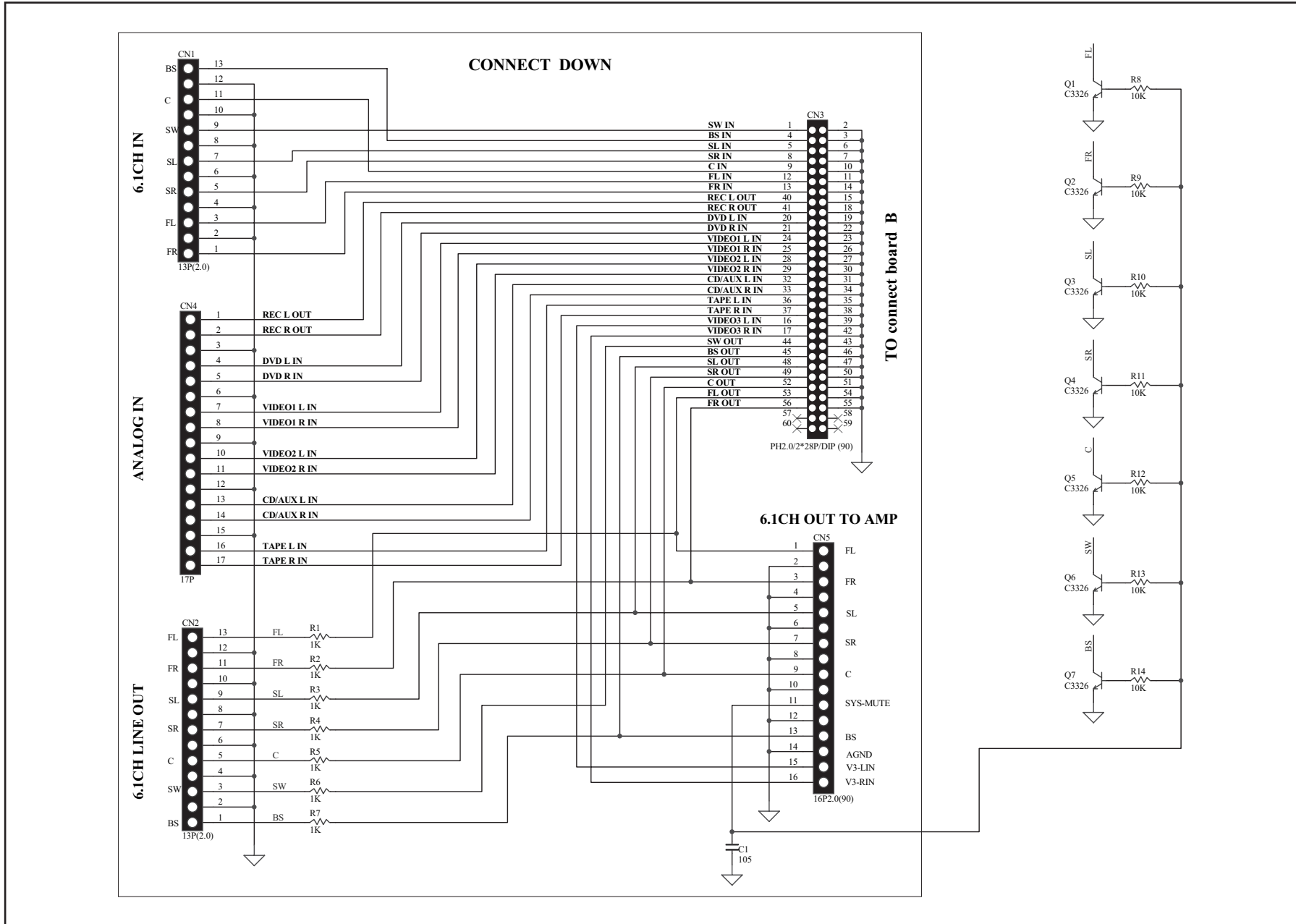

To enhance viewing, please print to A3

## Connect Down PCB Schematic

# Cambridge Audio Azur 540R V2.0 AV Receiver

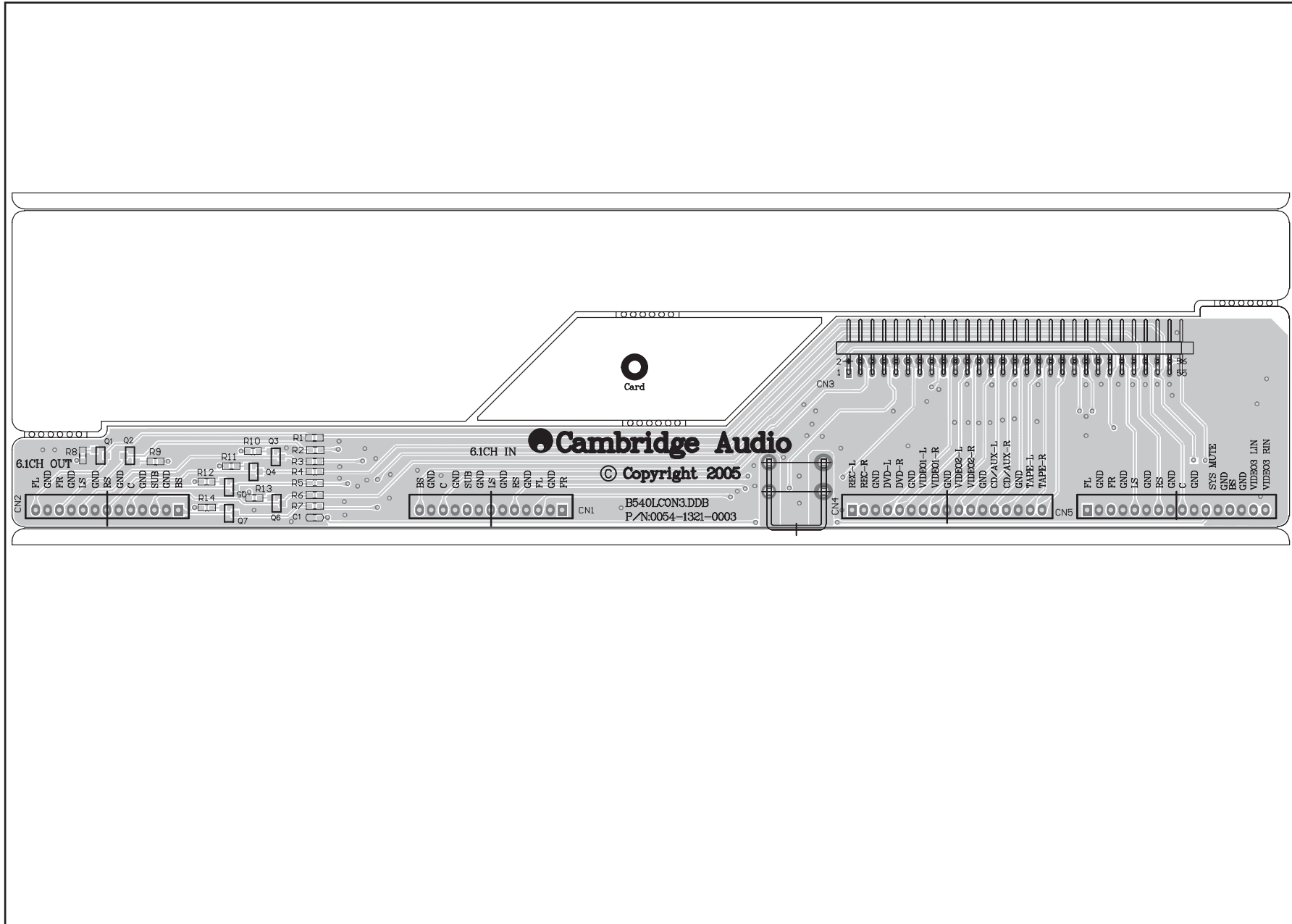

# Cambridge Audio Azur 540R V2.0 AV Receiver

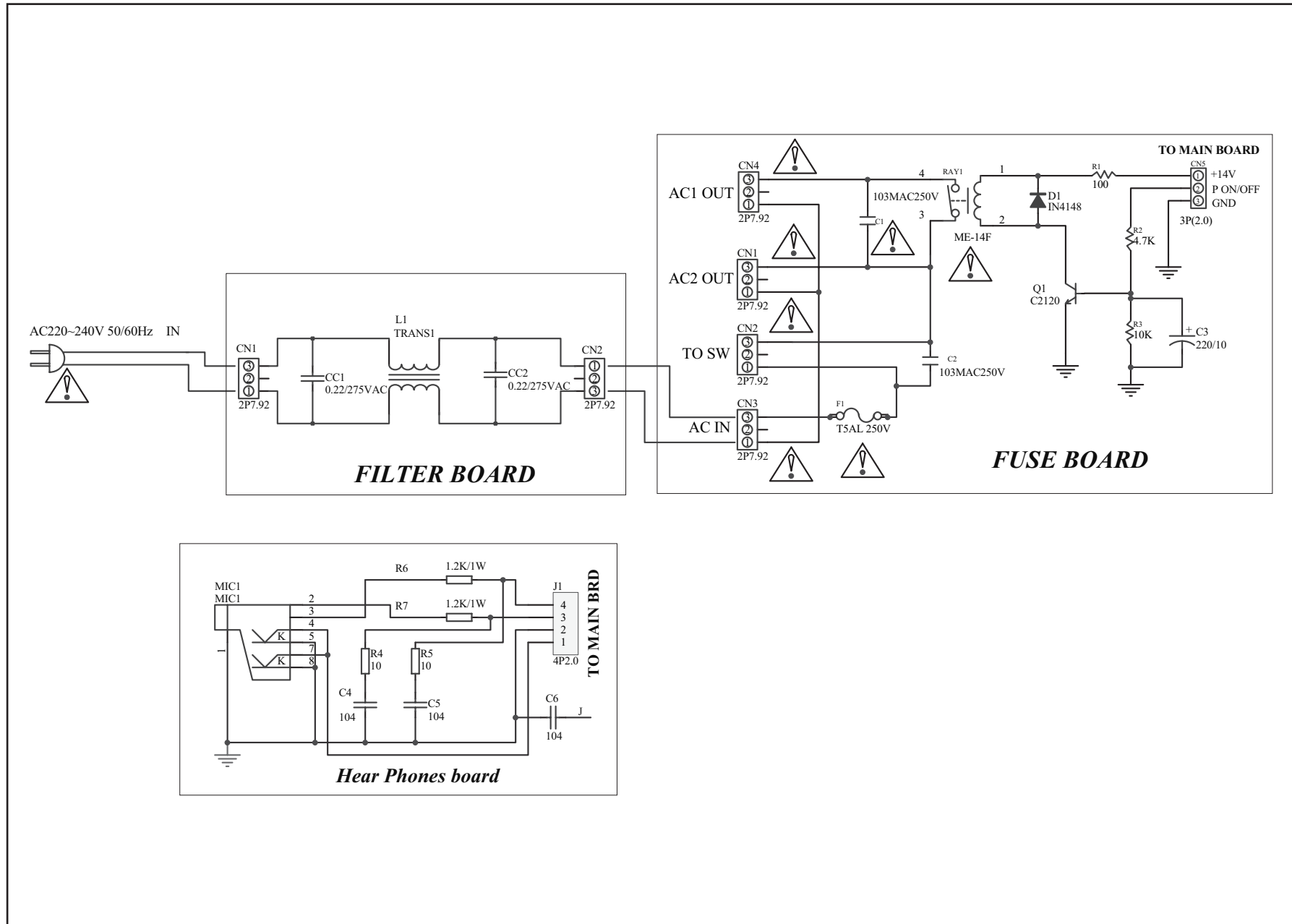

To enhance viewing, please print to A3

## AC Input, Relay & Headphones PCB Schematic





## Cambridge Azur 540R V2.0 AV Receiver

Used	Part Type	Designator Description
1	MB252	BL1
1	DB101G	BL2
6	10U/16V	C1 C18 C19 C39 C58 C83
6	152M	C2 C20 C21 C41 C59 C84
6	47P	C3 C22 C23 C43 C60 C85
6	122M	C4 C24 C25 C45 C63 C87
6	102	C5 C26 C46 C61 C62 C86
7	100U/16	C6 C27 C28 C47 C64 C88 C95
6	12P	C7 C29 C30 C49 C65 C89
6	20P	C8 C31 C51 C66 C67 C90
6	47UF/50V	C9 C32 C33 C52 C68 C91
12	150P	C10 C11 C34 C35 C36 C54 C56 C69 C70 C71 C92 C93
12	104	C12 C37 C110 C122 C123 C130 C151 C152 C158 C159 C160 C161
6	2.2U/50V/NP	C13 C14 C38 C74 C75 C76
2	470U/10	C15 C171
1	473	C16
16	104	C17 C42 C44 C48 C50 C53 C55 C57 C72 C73 C77 C78 C79 C80 C94 C141
1	4.7U/25	C40
2	330P	C81 C82
2	470U/25	C96 C101
3	104M	C97 C98 C105
2	10000U/63	C99 C100
1	47U/16	C102
2	10U/50	C103 C180
1	47U/35	C104
1	1000U/25	C106
1	330U/63	C107
1	22U/25	C108
1	2200U/10	C109
25	330P	C111 C112 C113 C114 C124 C125 C126 C127 C128 C129 C144 C145 C146 C147 C148 C149 C153 C154 C155 C156 C157 C162 C163 C164 C165 C115 C116 C117 C118 C119 C120
6	10UF/16V	C121
1	47UF/25V	C131
1	10UF/16	C142
1	470P	C179
1	220U/16	CN1 CN8 CN9
3	2P(2.5)	CN2 CN11 CN21
3	3P(2.0)	CN3 CN22
2	2P(2.0)	CN4
1	3P(3.96)	CN5
1	6P(2.0)	CN6
1	2P(2.5)	CN7
1	3P(2.5)	CN10
1	7P(2.0)	CN12
1	17P2.0(180)	CN13
1	5P(2.0)	CN14 CN15
2	13P2.0DIP(180)	CN16
1	10P2.5	CN17
1	4P(2.0)	CN18
1	16P2.0(180)	CN20
1	7P(2.5)	CN23
1	2P2.5	D1 D2 D3 D4 D5 D6 D7 D9 D10 D11 D12 D13 D14 D15 D16 D17 D18 D19 D20 D21 D22 D23 D24 D25 D27 D28 D29 D30 D31 D34 D35 D36 D37 D38 D45
35	1N4148	

## Cambridge Azur 540R V2.0 AV Receiver

1	IN4001	D8
3	1N4001	D26 D43 D44
2	1N4148	D32 D33
2	1N4001	D39 D40
1	6C2	D41
1	1N4570(27V)	D42
12	6A3	DW1 DW2 DW3 DW4 DW5 DW6 DW7 DW8 DW9 DW10 DW13 DW14
2	5C2	DW11 DW12
1	1N4742A	DW15
2	T12AL 250V	FH1 FH2
1	7805	IC1
1	AV4-8.4-13/EC	JK1
5	AV2-8.4-13/ES	JK2 JK3 JK4 JK5 JK8
	AV6-8.4-13/EC	JK6 JK7
1	AV3-8.4-14	JK9
2	WP6-10B	JK10 JK11
1	RS232	JK12
2	JZC-42F	K1
2	JZC-42F	K2 K3
1	0.5UH	L1 L2 L3 L4 L5 L7
6	C2878	Q1 Q18 Q19 Q36 Q50 Q73 Q88
6	A970	Q2 Q4 Q14 Q20 Q21 Q23 Q24 Q37 Q41 Q51 Q54 Q74 Q76
1	C2240	Q3 Q11 Q22 Q34 Q35 Q39 Q52 Q53 Q64 Q65 Q75 Q83
5	C2705	Q5 Q25 Q42 Q55 Q56 Q77
7	D946BR	Q6 Q26 Q27 Q43 Q57 Q78
6	A940	Q7 Q28 Q44 Q58 Q59 Q79
6	C2073	Q8 Q29 Q30 Q45 Q60 Q80
2	B817	Q9 Q31 Q49 Q61 Q62 Q81
6	D1047	Q10 Q32 Q33 Q48 Q63 Q82
12	C2458	Q12 Q13 Q15 Q17 Q87
6	C2235	Q16
13	A1015	Q38 Q86
6	SS8050D(TO-92)	Q85
7	1.5K	R1 R12 R45 R46 R63 R64 R96 R112 R133 R145 R200 R210
1	6.8K	R2 R43 R44 R97 R132 R199
2	100K	R3 R38 R39 R47 R48 R99 R134 R201 R246
1	820	R4 R49 R50 R100 R135 R202 R230
1	47K	R5 R13 R32 R33 R51 R52 R65 R66 R102 R113 R124
12	1.8K	R6 R11 R53 R54 R62 R103 R111 R137 R143 R144 R204 R209
6	1.2K	R7 R55 R105 R138 R139 R205 R232
6	1K	R8 R26 R36 R40 R56 R57 R106 R140 R165 R206
12	8.2K	R9 R58 R59 R107 R141 R198 R207
1	470K	R10 R60 R61 R109 R142 R208
8	100	R14 R67 R115 R147 R148 R212 R239 R240
2	5.6K/0.25W	R15 R19 R68 R69 R74 R76 R116 R121 R149 R155 R213 R217
1	2K	R16 R70 R71 R118 R150 R214
1	2.7K	R17 R72 R119 R151 R152 R215
1	220	R18 R20 R73 R75 R77 R117 R120 R122 R123 R153 R154 R156
6	4.7/0.5W	R21 R23 R78 R79 R82 R125 R128 R157 R159 R160
6	220/0.25W	R22 R80 R81 R127 R158 R220
6	0.22/5WX2	R24 R83 R84 R129 R161 R222
7	10/0.25W	R25 R85 R130 R162 R163 R223
10	2.2K	R27 R28 R87 R88 R89 R90 R166 R167 R168 R179 R181 R224
22	22K	R29 R30 R31 R91 R92 R93 R94 R95 R131 R164 R169 R170
		R171 R172 R175 R177 R189 R226 R227 R228 R245 R247
1	10K	R34 R35 R37 R104
12	1/4W10	R41 R86 R98 R108 R110 R114

## Cambridge Azur 540R V2.0 AV Receiver

6	10/1W	R42
1	6.2K	R101
16	100	R126 R136 R146 R203 R211
1	4.7K	R173 R243
14	100K	R174
4	33K	R176
9	100	R178 R180
2	120	R216 R218
12	100	R219 R221
12	2.4K/3W	R229
1	270	R231
1	4.7/1W	R234
2	RF/0.22/1W	R235 R242
1	3.3K/1W	R241
6	470	R244
7	680K	R248
1	15K	R249
6	02DSB282J	RT1

### Bill of Material for coax.Bom

Used	Part Type	Designator
4	104	C62 C64 C65 C66
1	100/10	C63
7	105	C67 C68 C69 C70 C71 C72 C77
3	8P	C73 C74 C75
1	6P2.0	CN6
1	3P2.0	CN7
1	74HCU04D	IC9
1	AV4-8.4-14/EC	JK1
1	AV-8.4-8/ES	JK2
1	FB	L8
1	C3361	Q1
1	220	R41
2	4.7K	R42 R59
3	10	R65 R66 R67
3	75	R68 R70 R77
3	10K	R78 R79 R80
1	LTV817A	U6

### Bill of Material for CON.Bom

Used	Part Type	Designator
1	PH2.0/2*28P/DIP(180)	CN8
1	PH2.0/2*28P (180) H4.3	CN9

### Bill of Material for VIDEO&OSD.Bom

Used	Part Type	Designator
23	104	C1 C2 C3 C4 C5 C6 C9 C10 C11 C12 C13 C14 C15 C16 C17 C18 C42 C49 C55 C56 C76 C84 C90
8	100/10	C7 C8 C33 C41 C48 C82 C83 C87
	105	C19 C20 C21 C22 C23 C24 C39 C40 C50 C52 C57 C58 C59 C60 C78 C91

## Cambridge Azur 540R V2.0 AV Receiver

9	473	C25 C26 C27 C28 C29 C30 C51 C53 C61
5	47/16	C31 C32 C37 C43 C54
3	100P	C34 C35 C36
1	681	C38
2	15P	C44 C45
2	24P	C46 C47
2	102	C79 C94
2	20p	C80 C89
2	22/16	C81 C88
2	10.0/16	C85 C86
1	270	C92
1	560P	C93
1	220	C95
1	47P	C96
1	103	C97
1	7P2.0	CN1
2	6P2.0	CN2 CN3
1	640 6P2.0 / 540R 2P2.0	CN4
1	5P2.0	CN5
3	1N4148	D1 D2 D3
2	TC74HC4052AF	IC1 IC2
2	TC74HC4053AF	IC3 IC6
1	NJM2581M	IC4
1	LC74786M	IC5
1	TC4094AFN	IC7
1	74HCU04D	IC8
1	NJM2267	IC10
2	0	JP1 JP2
12	FB	L1 L2 L3 L4 L5 L6 L7 L9 L10 L11 L13 L20
1	33uH	L12
1	56uH	L14
4	DASW-02	P1 P2 P3 P4
5	C3361	Q3 Q4 Q5 Q6 Q9
1	A1331	Q8
	75	R1 R2 R3 R4 R5 R11 R12 R13 R17 R18 R19 R20 R21 R22 R24 R27 R28 R29
4	330	R6 R62 R71 R73
2	4.7K	R7 R54
6	100	R8 R9 R23 R25 R52 R89
13	10	R10 R44 R45 R46 R47 R48 R49 R51 R53 R57 R63 R64 R72
1	47	R14
1	18	R15
1	33	R16
1	820	R26
3	22K	R30 R43 R75
10	10K	R31 R32 R33 R34 R35 R36 R40 R60 R69 R86
3	560	R37 R38 R39
3	470	R50 R84 R88
1	DEL	R56
2	220	R55 R61
1	91	R58
1	270	R74
1	220K	R76
1	8.2K	R81
1	39	R82
1	100K	R83
1	12K	R85
1	15K	R87

## Cambridge Azur 540R V2.0 AV Receiver

3	TORX179	U1 U2 U3
1	GP1F32T	U4
1	TC74HC151AP	U5
1	17.734475M	X1
1	14.31818M	X2

### Bill of Material for Y U V.Bom

Used	Part Type	Designator
1	103M/100V	C1
2	10.0-00	C2 C3
4	100/10	C4 C5 C15 C16
16	104	C6 C7 C8 C9 C10 C11 C17 C18 C19 C20 C21 C22 C26 C27 C28 C29
3	47/16	C12 C13 C14
3	47P	C23 C24 C25
1	3P2.5	CN1
1	7P2.0	CN2
1	DB104G	D1
1	NJM7905FA	IC1
1	NJM7905FA	IC2
1	TC74HC4053AF	IC3
1	NJM2581M	IC4
3	AV3-8.4-14/EC	JK1 JK2 JK3
1	DT 4114L(9.5mm)	K1
2	47uH	L1 L2
2	FR0.22/0.25W	R1 R2
9	10K	R3 R4 R5 R6 R7 R8 R9 R10 R11
2	10	R12 R13
3	75	R14 R15 R16
1	1	R17

### Bill Of Materials for Display&Coax .Bom

Used	Part Type	Designator Description
3	0.1uF	C1 C3 C7
1	10.0/10	C2
1	100/16	C4
2	103	C8 C10
4	104	C9 C11 C12 C14
1	10.0/16	C13
1	100/10	C15
3	224	C16 C17 C18
7	1N4148	D1 D2 D3 D5 D9 D30 D32
1	∅ 3mm Blue LED	D31
1	RPM-638CBR-L	IR1
1	6P*2.0	J1
1	D100-SRA-16	J2
1	AV3-8.4-14/EC	J3
1	5P*2.5	J4
1	10uH	L1
6	2SC2120	Q1 Q2 Q5 Q7 Q9 Q11
6	A1015	Q3 Q4 Q6 Q8 Q10 Q12
1	C2458	Q13
1	56K	R1
4	10K	R2 R3 R4 R5

## Cambridge Azur 540R V2.0 AV Receiver

14	1K	R6 R8 R9 R11 R12 R14 R15 R17 R18 R20 R21 R23 R47 R51
6	100K	R7 R10 R13 R16 R19 R22
6	18K	R24 R26 R28 R30 R32 R34
6	3K3	R25 R27 R29 R31 R33 R35
2	22K	R43 R44
1	1K5	R45
2	1M	R46 R50
4	75	R48 R52 R60 R61
2	10M	R49 R53
1	430	R54
1	91	R55
1	6K8	R56
17	DT4113F	S1 S2 S3 S4 S5 S6 S7 S8 S9 S10 S11 S12 S16 S17 S18 S19 S20
1	X	TP1
1	HL-D135A	U1
1	UPD16311	U2
1	TC4094(DIP16)	U4
1	74HCU04D	U5
1	EC16B241047AA	VR3

# Cambridge Audio Azur 540R V2.0 AV Receiver

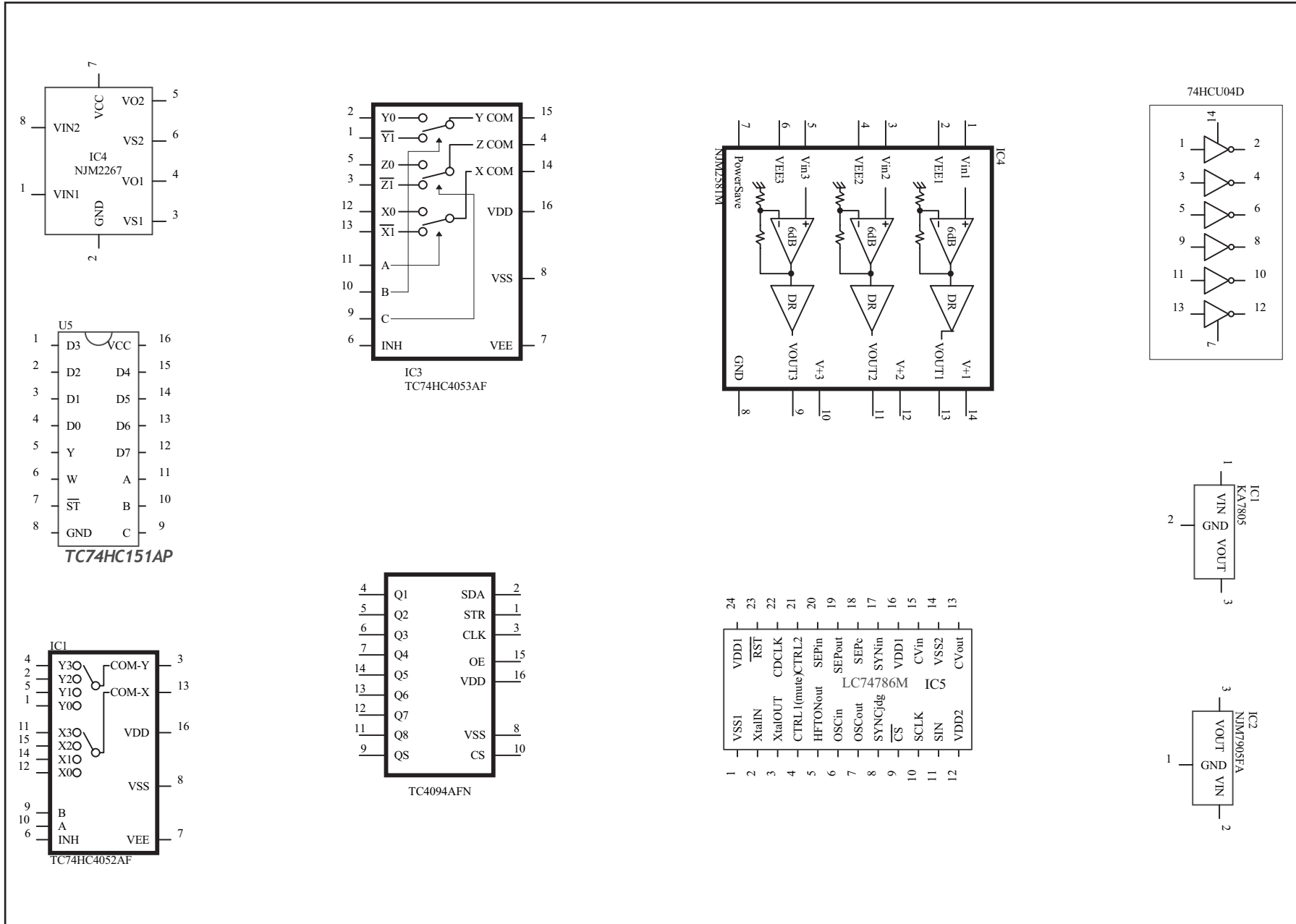

To enhance viewing, please print to A3

# Cambridge Audio Azur 540R V2.0 AV Receiver

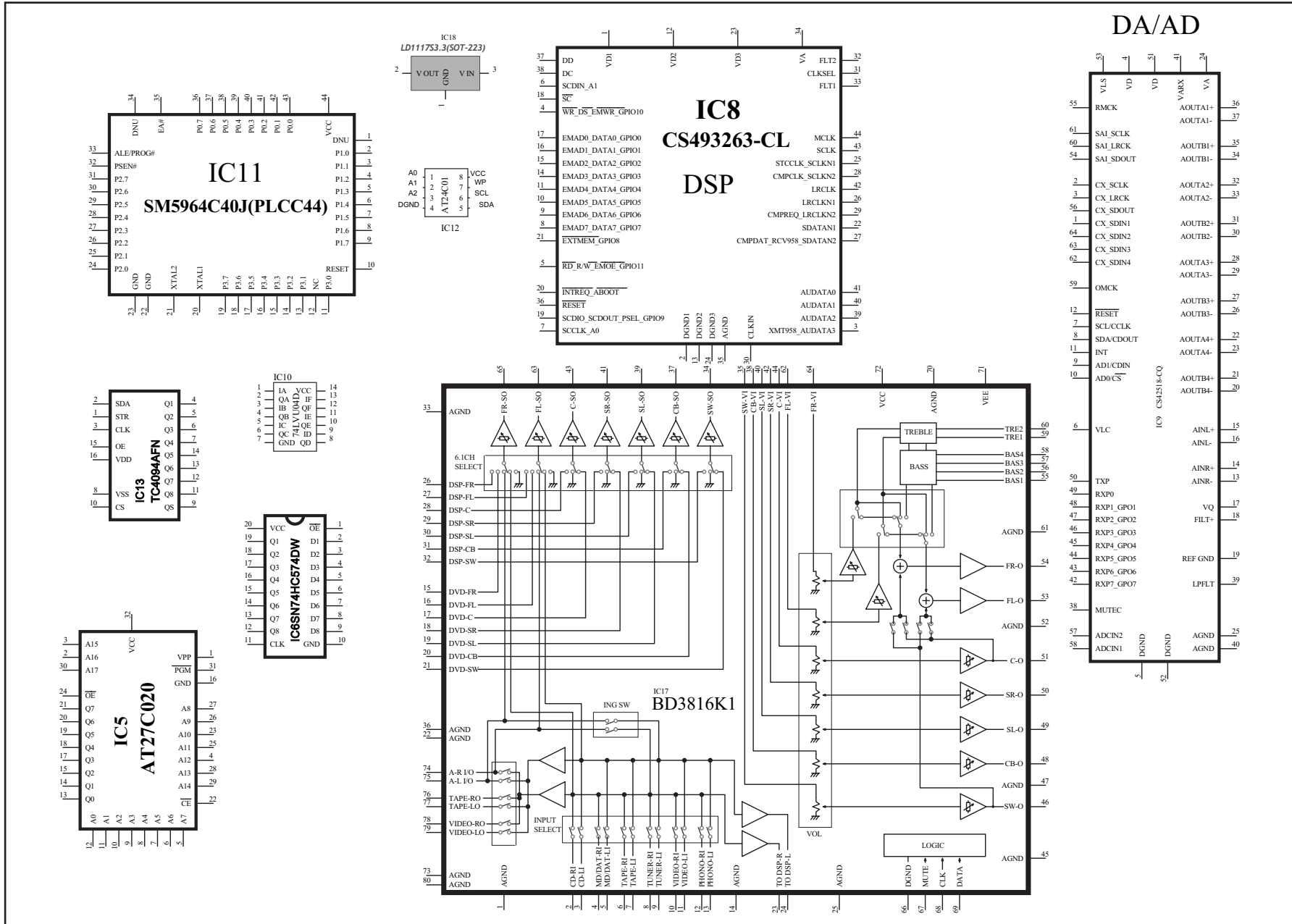

To enhance viewing, please print to A3

## IC Pin Layout Details (2 of 2)



## Cambridge Audio Azur 540R V2.0 AV Receiver

PF015	111094000160	2SA940
PF016	112081700140	2SB817
PF017	113207300160	2SC2073
PF018		2SD946BR
PF019	114104700130	2SD1047
PF024	4000 1355 1000	EI 35 standby transformer (sames as 540R V1)
PF034	7531-1040-0000	Right support 540R
PF035	7531-1050-0000	Left support 540R
PF041		Transistor 2SC 2705
PF050	4000 1015 0000	540R V2 Mains transformer CU
PF051	4000 1015 0000	540R V2 Mains transformer EU
PF052	0054 1016 4000	540R V2 Decode PCB complete
PF053	9800 0003 0001	540R V2 Tuner box EU
PF054	9800 0003 0001	540R V2 Tuner box CU
PF055	0054 1014 2000	540R V2 YUV PCB complete
PF056	small cover over f/p inputs	540R V2 AV3 front cover
PF057	UPD16311	540R V2 U2 display driver IC
PF058	IC5 OSD	540R V2 LC7486M
PF059	IC 11 MCU (USA version)	540R V2 SM5964C40J (programmed for CU version)
PF060	IC11 MCU (Europe version)	540R V2 SM5964C40J (programmed for EU version)
PF061	IC17 volume	540R V2 BD3816K1
PF062	VR3 master volume encoder	540R V2 EC16B241047AA
PF063	0054-1303-2005	540R V2 Main Board
PF064		AV3 FRONT COVER SILVER FOR 540R V2
PF065	LC74786M	IC LC74786M for 540R V2
PF066	0054-1030-0004	Display PCB for 540R V2
PF071	1350-0006-3014	6A3 540R (diode zeener)
PF072	9800-0003-0111	540R V2 Tuner Module (RBDS) CU version
PF073		540R V2 Resistor 0.27/5WX
PF074	IC9 on Coax PCB	74HCU04D IC for 540R V2
PF076	IC4 on YUV PCB	NJM2581M for 540R V2
PY1109	9802-054000-101	540R V2 remote control
PY713	6554-150004-000-01	SIDE COVER (RIGHT) (BLACK)
PY714	6554-150004-000-02	SIDE COVER (RIGHT) (SILVER)
PY715	6554-150005-000-01	SIDE COVER (LEFT) (BLACK)
PY716	6554-150005-000-02	SIDE COVER (LEFT) (SILVER)
PY717	6554-150003-000-01	TOP COVER (BLACK)
PY718	6554-150003-000-02	TOP COVER (SILVER)
PY1168		Silver front panel metalwork
PY1169		Black front panel metalwork