

Issue Date: 22nd March 2006

SERVICE MANUAL



SPECIFICATIONS:

Power Output	75W (into 8 Ω) 120W (into 4 Ω)
THD (unweighted)	<0.002% @ 1kHz, of rated power <0.050% 20Hz – 20kHz, of rated power <0.020% 20Hz – 20kHz @ 10w
Frequency response (-1 dB)	5Hz – 50kHz
S/N ratio (ref 1w)	>90dB
Input impedances	47kohms
Power Amp damping factor	> 100
Max power consumption	700w
Min/On power consumption	<35w (no signal)
Standby power consumption	<10w
Bass / Treble controls	shelving, ultimate boost/cut + /-7.5dB @ 20Hz and 20kHz
Dimensions	100 x 430 x 310mm (3.9 x 16.9 x 12.2")
Weight	7.4kg (16.3Lbs)

API9855/1

640A V2.0 SERVICE MANUAL

TABLE OF CONTENTS

Safety Precautions & Important Notes	3
Exploded Diagram	4
Input PCB Schematic (Power Supply)	5
Input PCB Schematic (Buffers and Switches)	6
Input PCB Schematic (Tone Control)	7
Input PCB Schematic (Protection Circuitry)	8
Input PCB Schematic (Headphone Driver)	9
Input PCB Layout (Top Side)	10
Input PCB Layout (Bottom Side)	11
Input PCB Assembly BOM	12-13
Voltage Select Switch PCB Schematic	14
Voltage Select PCB Layout (Top Side)	15
Voltage Select PCB Layout (Bottom Side)	16
Voltage Select PCB Assembly BOM	17
Mains PCB Schematic	18
Front Panel PCB Schematic	19
Mains & Front Panel PCB Layout (Top Side)	20
Mains & Front Panel PCB Layout (Bottom Side)	21
Mains & Front Panel PCB Assembly BOM	22
Amp PCB Schematic (Right Channel)	23
Amp PCB Schematic (Protection)	24
Amp PCB Schematic (Power Amp)	25
Amp PCB Schematic (Left Channel)	26
Amp PCB Layout (Top Side)	27
Amp PCB Layout (Bottom Side)	28
Amp PCB Assembly BOM	29-31
Abus Module PCB Schematic	32
Abus Module PCB Layout (Top Side)	33
Abus Module PCB Layout (Bottom Side)	34
Abus PCB Assembly BOM	35
IC Pin Layout Details	36-42

SAFETY PRECAUTIONS & IMPORTANT NOTES

1. Check that the rear of the product indicates the correct supply voltage for your area.



2. The lighting flash with the arrowhead within an equilateral triangle is intended to alert the user or service agent to the presence of dangerous voltages within the product enclosure that may be of sufficient magnitude to constitute a risk of electric shock to persons.



3. The exclamation point within an equilateral triangle is intended to alert the user or service agent to the presence of important operating and maintenance (Servicing) instructions in the literature accompanying the appliance.

4. This product complies with EEC Low Voltage (73/23/EEC) and Electromagnetic Compatibility (89/336/EEC) Directives when used and serviced in accordance with this manual. For continued compliance all components marked safety and EMC critical must only be replaced by Cambridge Audio approved parts.

5. Any unauthorised design alterations or additions will void the manufacturer's warranty; furthermore the manufacturer cannot accept responsibility for personal injury or property damage resulting therefrom.

6. When servicing, care should be taken to observe the original routing and dressing of the leads and it should be confirmed that they have been returned to normal after re-assembly.

Notes on chip component replacement

Never reuse a component that has been removed from a PCB

Notice that the minus side of a tantalum capacitor may be damaged by heat

COPYRIGHT NOTICE.

© 2005 Audio Partnership PLC. All rights reserved.

Cambridge Audio and Azur are registered trademarks for Audio Partnership PLC. This document may not be reproduced, distributed, transmitted, displayed, published, or broadcast without the express written prior permission of Audio Partnership PLC.

Alteration or removal of any trademark, copyright, or other notice from this content is prohibited.

Information provided in this document is provided solely for the use of official service agents in repairing and servicing Audio Partnership PLC products.

Drawing ref/AP Part	Factory part number	Description
1	PY687	VOLUME KNOB ALUMINIUM SKIN AP133601 SILVER (use with PY680-PY681)
1	PY686	VOLUME KNOB ALUMINIUM SKIN AP133601 BLACK (use with PY680-PY681)
2	PY692	Azur-640A SELECTOR KNOB SILVER
2	PY693	Azur-640A SELECTOR KNOB BLACK
3	PY719	7MM TAC SWITCH BUTTON (BLACK)
3	PY720	7MM TAC SWITCH BUTTON (SILVER)
4	6050-150012-000A01	7MM PUSH SWITCH BUTTON SILVER FOR Azur-640A
4	6050-150013-000A01	7MM PUSH SWITCH BUTTON BLACK FOR Azur-640A
5	6050-117821-000-02	Azur-640A CONTROL BOX/BUTTON SILVER
5	6050-117821-000-01	Azur-640A CONTROL BOX/BUTTON BLACK
6	PY641	PLASTIC FOOT SILVER
6	PY631	PLASTIC FOOT BLACK
7	PY644	FOOT PAD FOR AZUR RANGE
8	PY1031	Transformer 115/230V 32.5V/2@32.5 2/2A 17V*2/0.4A Azur-640A V2
9	PY1032	LARGER SIDE PANEL SILVER PAINTED
9	PY1033	LARGER SIDE PANEL BLACK PAINTED
10	PY1034	V2 AMP TOP PANEL SILVER PAINTED
10	PY1035	V2 AMP TOP PANEL BLACK PAINTED
11	PY1036	LARGER SUPPORT FRONT ASSY (WITH TWO BRASS INSERTS)
11	PY1037	LARGER SUPPORT REAR ASSY (WITH TWO BRASS INSERTS)
12	PY1038	Azur-640A V2-SILVER AMP FRONT PANEL ASSY
13	PY1039	Azur-640A V2-BLACK AMP FRONT PANEL ASSY
14	PY1040	Azur-640A/540A V2 PIC CONTROL BOARD ASSY REV A
15	PY1041	Azur-640A/540A V2 POWER SWITCH PCB REV A
16	PY1042	Azur-640A/540A V2 LED PCB ASSY REV A
16	PY1043	Azur-640A V2 POWER INPUT BOARD ASSY REV A
17	PY1044	Azur-640A V2 AMP POWER PCB ASSY REV A
18	PY1045	640A/540A V2 PROTECTION CIRCUITRY PCB-A ASSY REV A
19	PY1046	640A/540A V2 PROTECTION CIRCUITRY PCB-B ASSY REV A
20	PY1047	Azur-640A/540A A-Bus Hub PCB ASSY REV A
21	PY1048	Azur-640A/540A V2 INFLU PCB ASSY REV A
22	PY1049	Azur-640A/540A V2 SPEAKER CONN. BOARD ASSY REV A
23	PY944	Azur-540A/C/640A/C V2.0 REMOTE CONTROL ASSY REV A
24	PY945	BATTERY DOOR FOR Azur RIC BLACK PAINTED
24	PY1057	Azur 640A V2.0 FRONT PANEL-Silver (Metal only)
24	PY1055	Azur 640A V2.0 FRONT PANEL-Black (Metal only)
25	PY515	Screw M2.6 x 8 M/C Torx Recessed 1/K Head Black
25	PY516	Screw M2.6 x 8 M/C Torx Recessed 1/K Head EndPlated
25	PY1051	Azur-540A/640A V2 USER'S MANUAL (AP183031)
25	5100-641500E900	

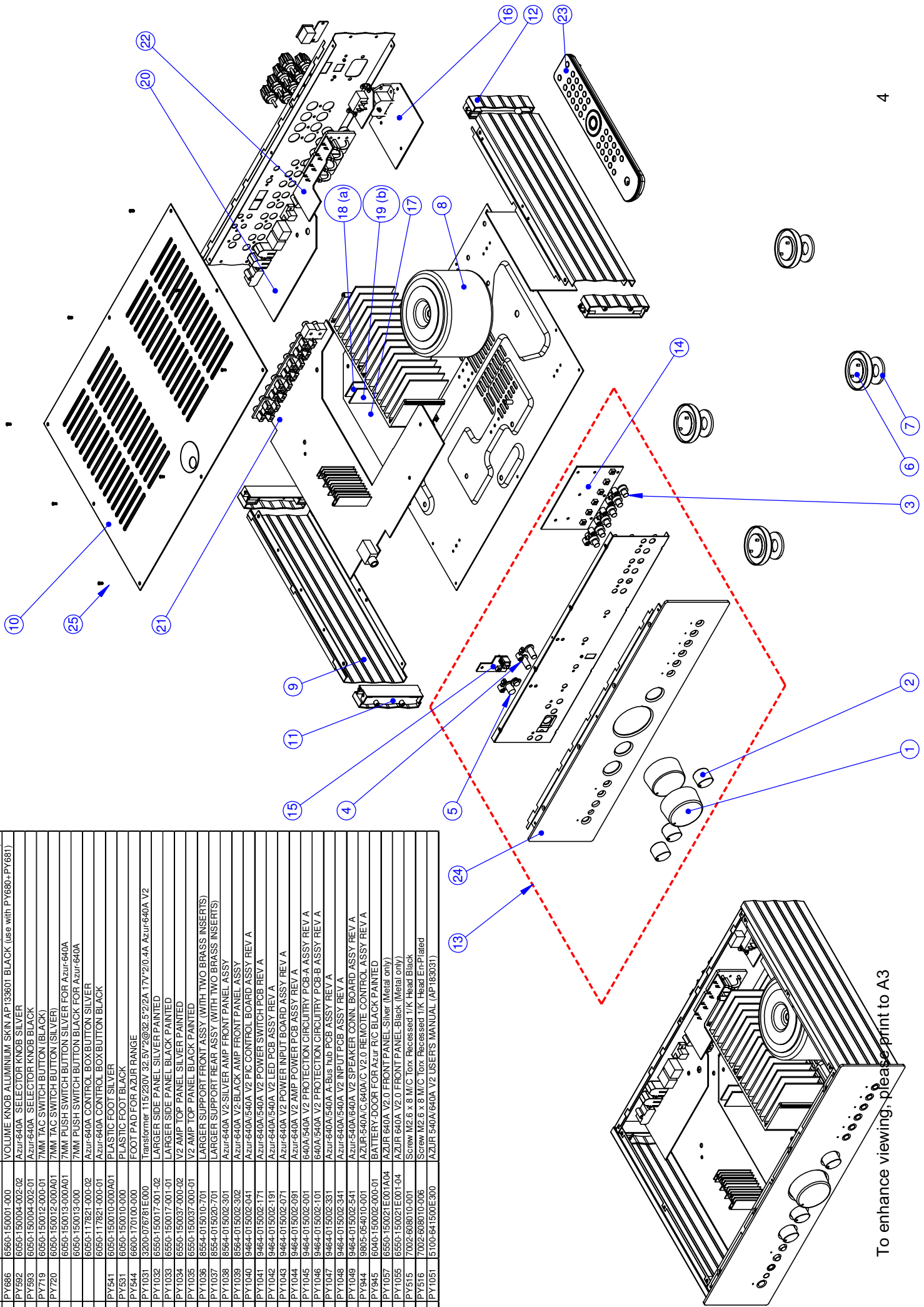

To enhance viewing, please print to A3

Cambridge Audio Azur 640A V2.0 Amplifier

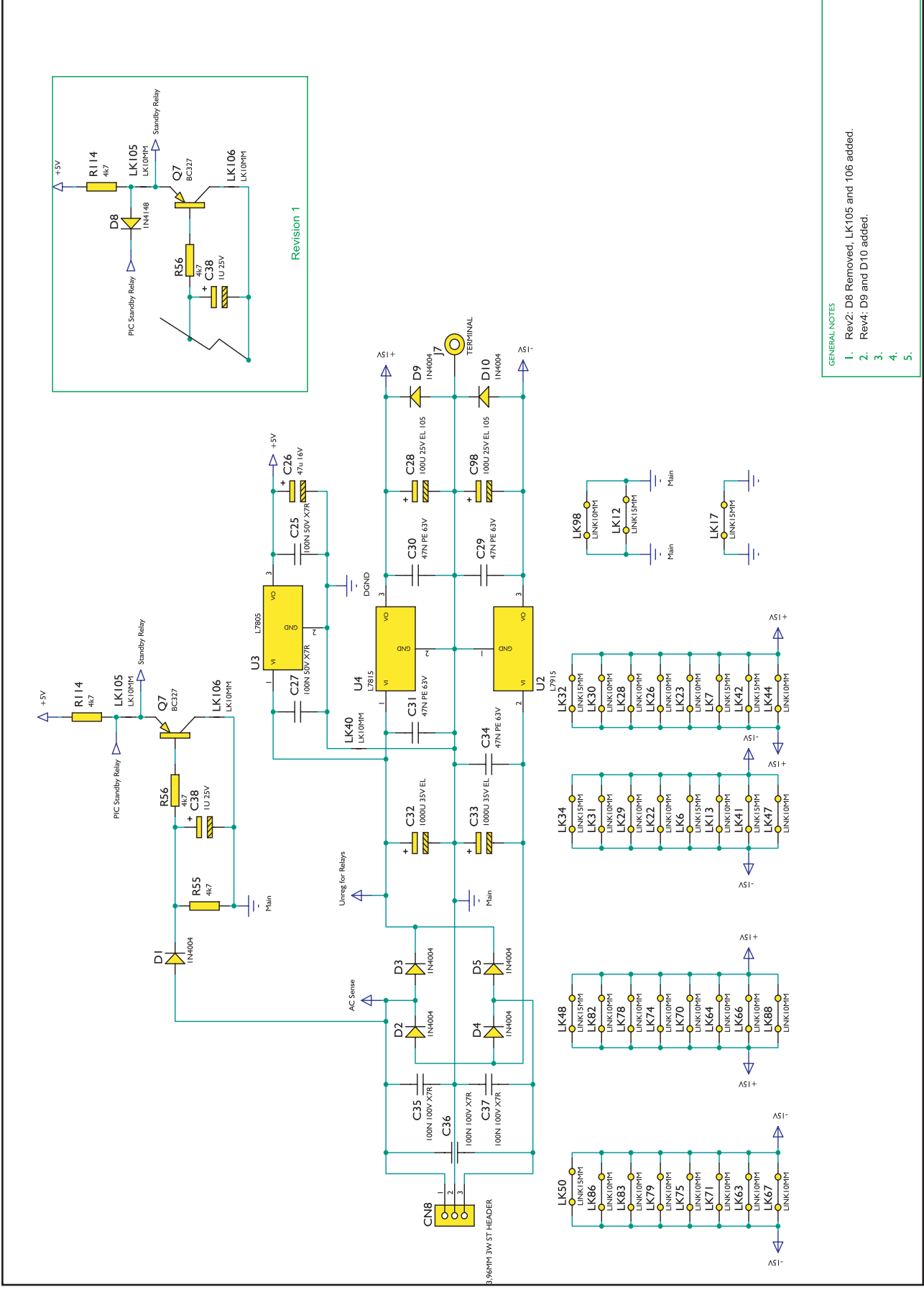

GENERAL NOTES

1. Rev2: D8 Removed, LK105 and 106 added.
2. Rev4: D9 and D10 added.
- 3.
- 4.
- 5.

Cambridge Audio Azur 640A V2.0 Amplifier

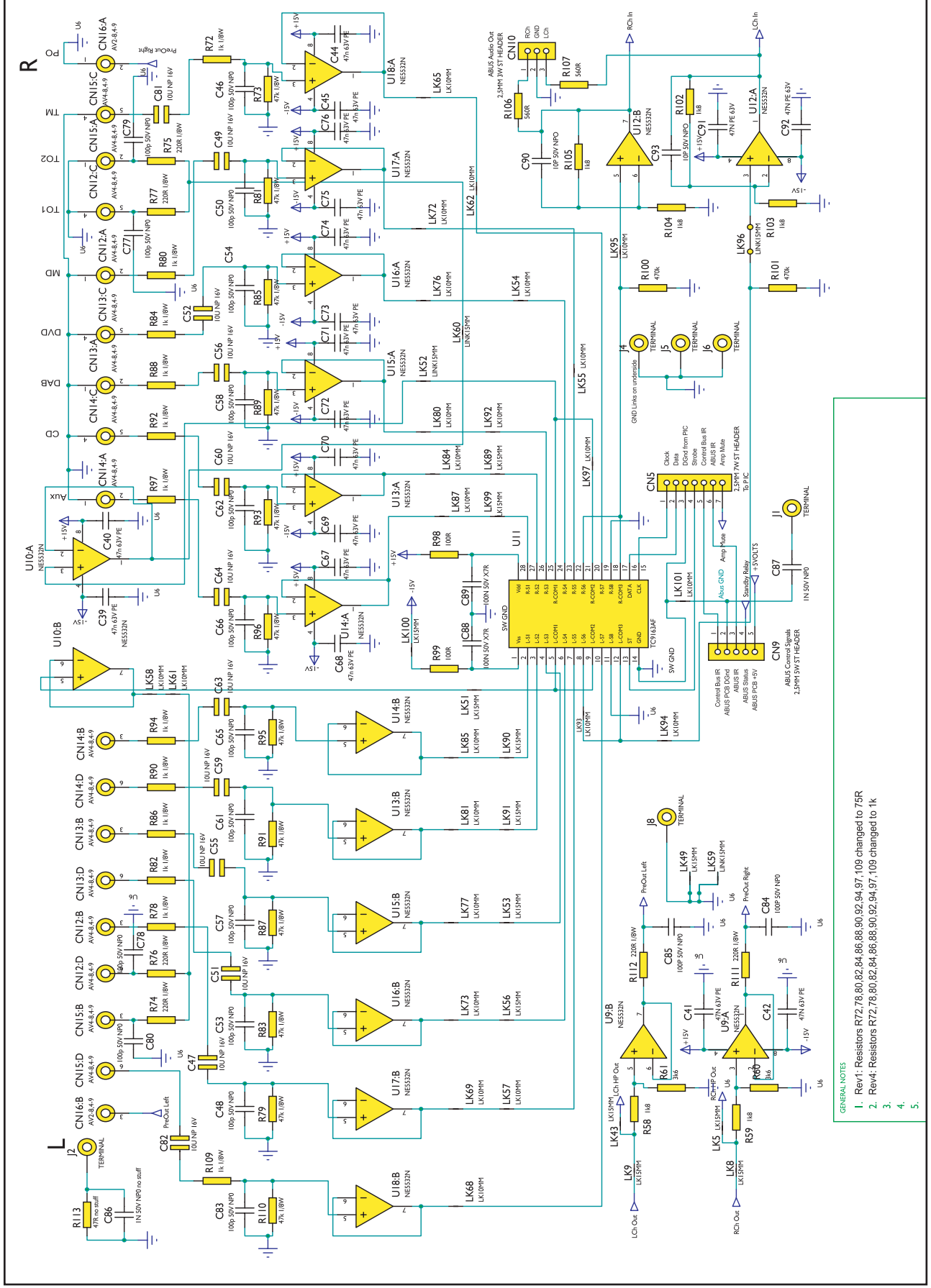

- GENERAL NOTES
1. Rev1: Resistors R72,78,80,82,84,86,88,90,92,94,97,109 changed to 75R
 2. Rev1: Resistors R72,78,80,82,84,86,88,90,92,94,97,109 changed to 1k
 - 3.
 - 4.
 - 5.

Cambridge Audio Azur 640A V2.0 Amplifier

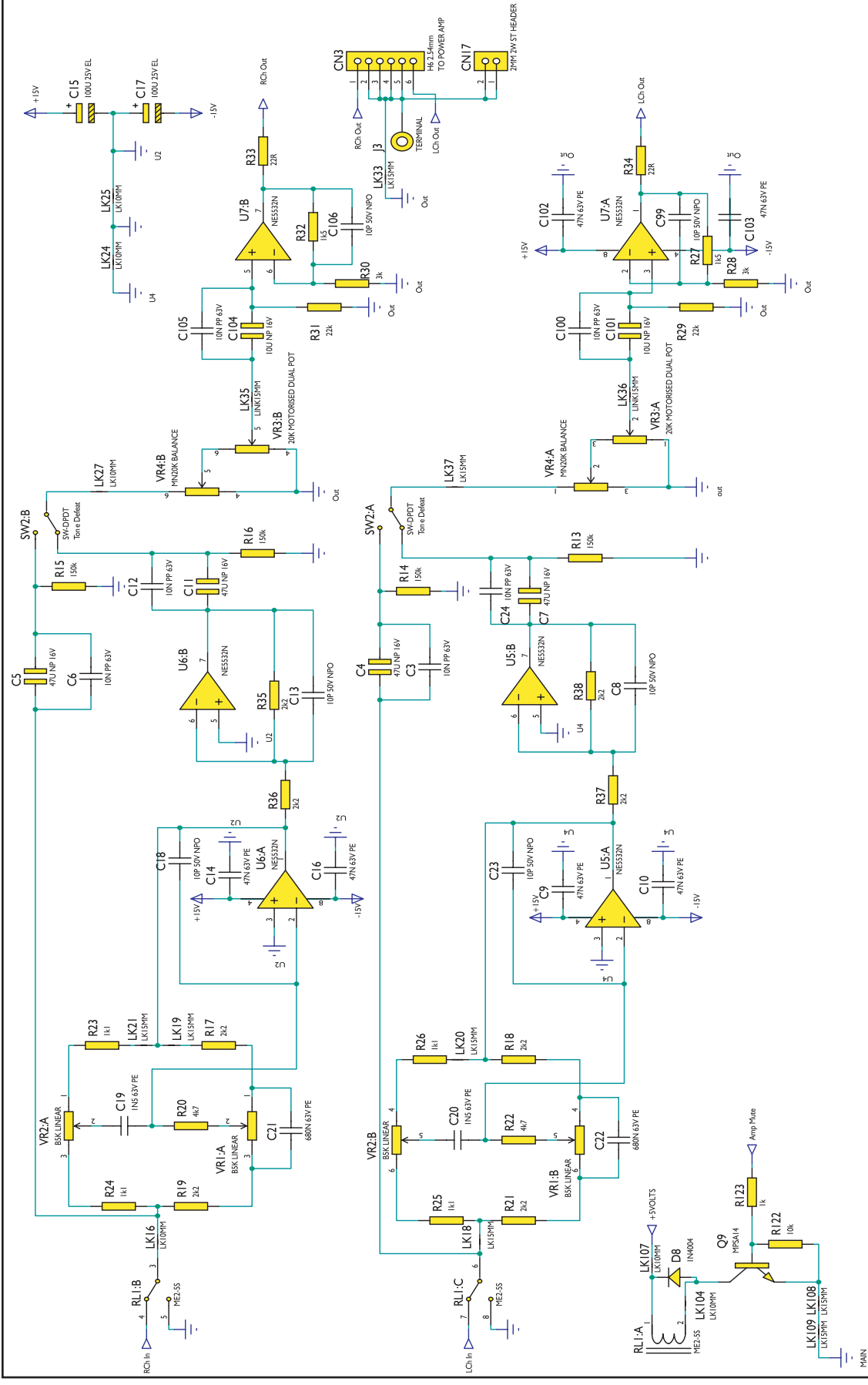

- GENERAL NOTES
1. Rev2: RL1, D8, Q9, R122, R123, LK104, 107-109 added.
 - 2.
 - 3.
 - 4.
 - 5.

Cambridge Audio Azur 640A V2.0 Amplifier

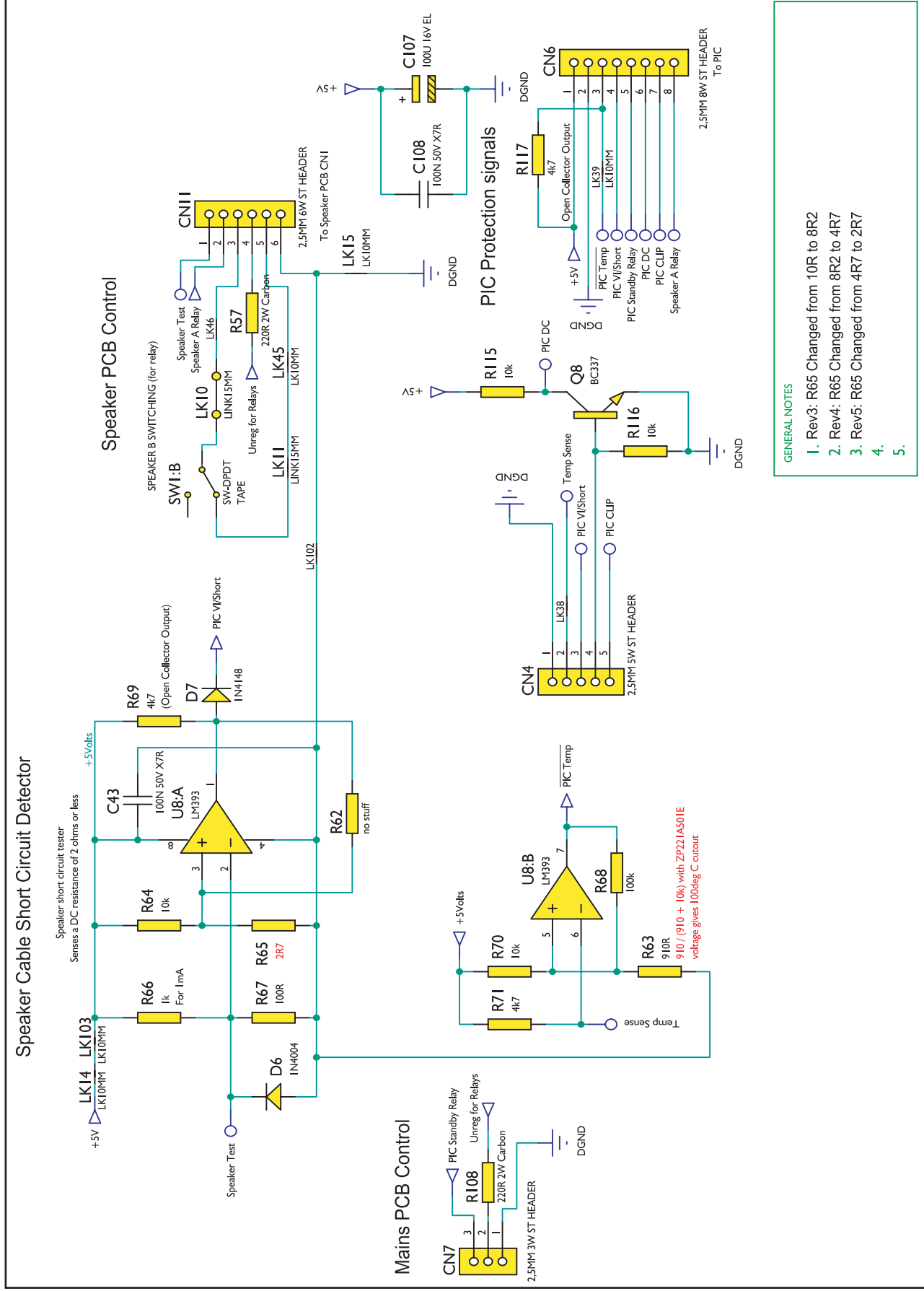

Cambridge Audio Azur 640A V2.0 Amplifier

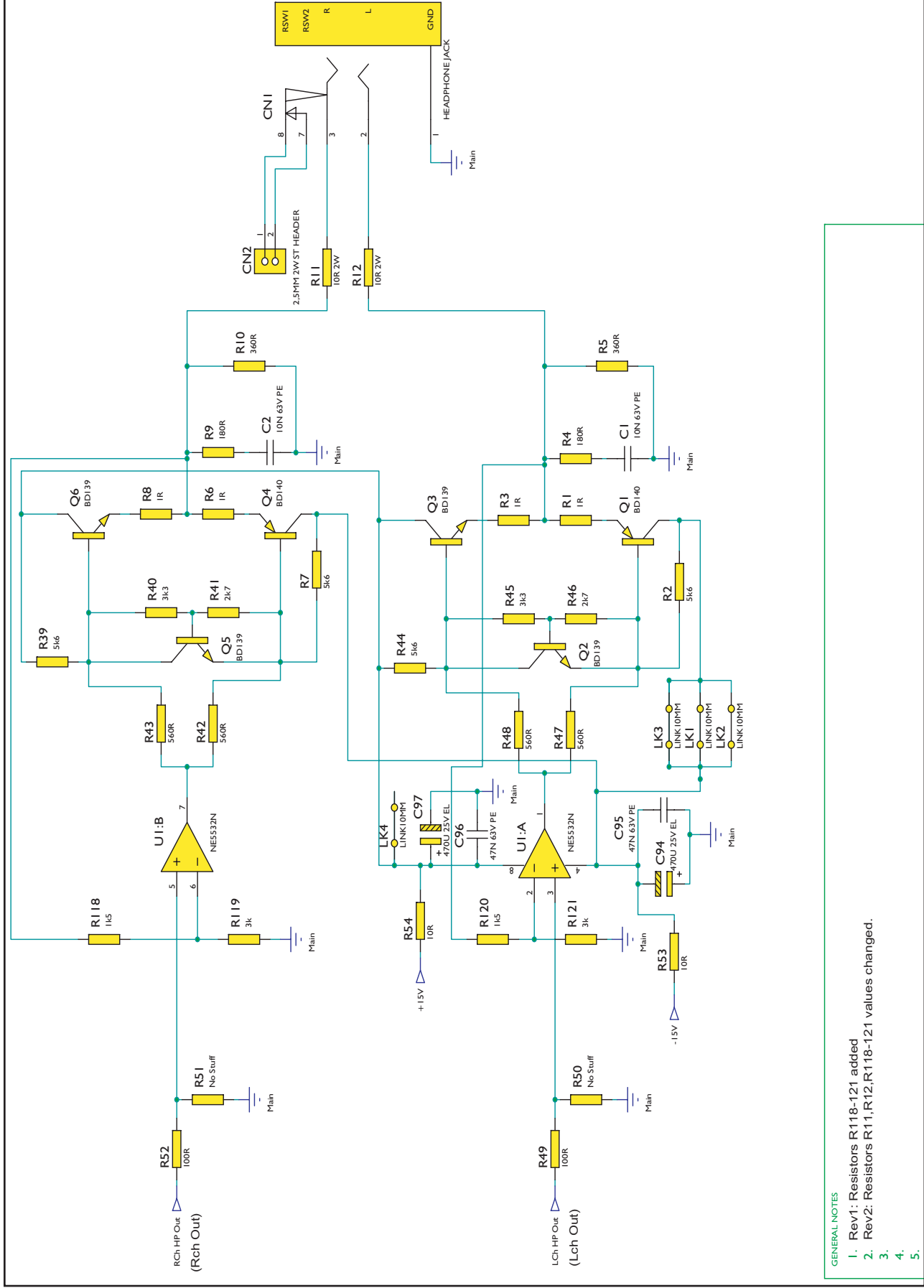

GENERAL NOTES

1. Rev1: Resistors R118-121 added
2. Rev2: Resistors R11,R12,R118-121 values changed.
- 3.
- 4.
- 5.

Cambridge Audio Azur 640A V2.0 Amplifier

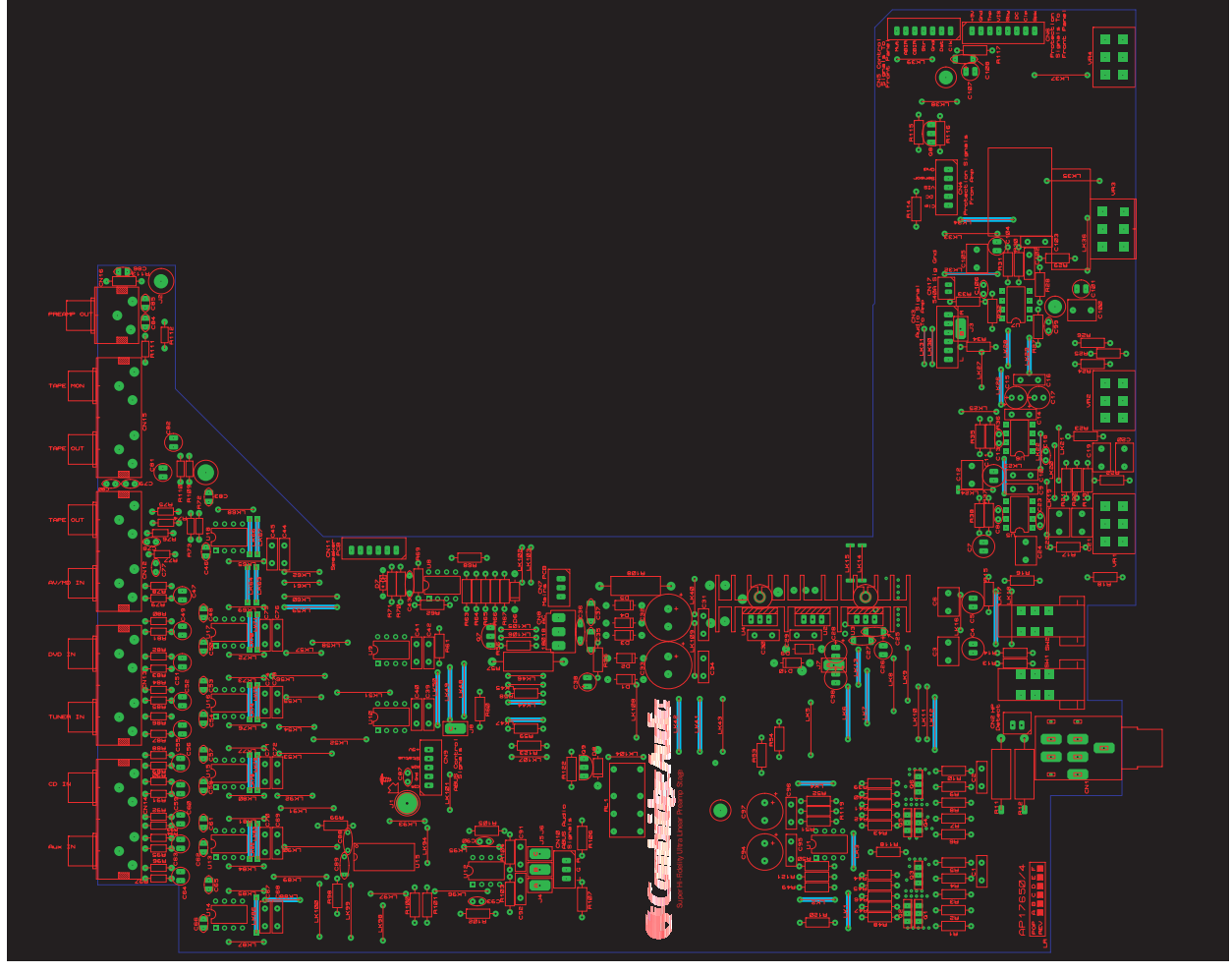

To enhance viewing, please print to A3

API 7649/4 Input PCB Board Layout (Top Side)

Cambridge Audio Azur 640A V2.0 Amplifier

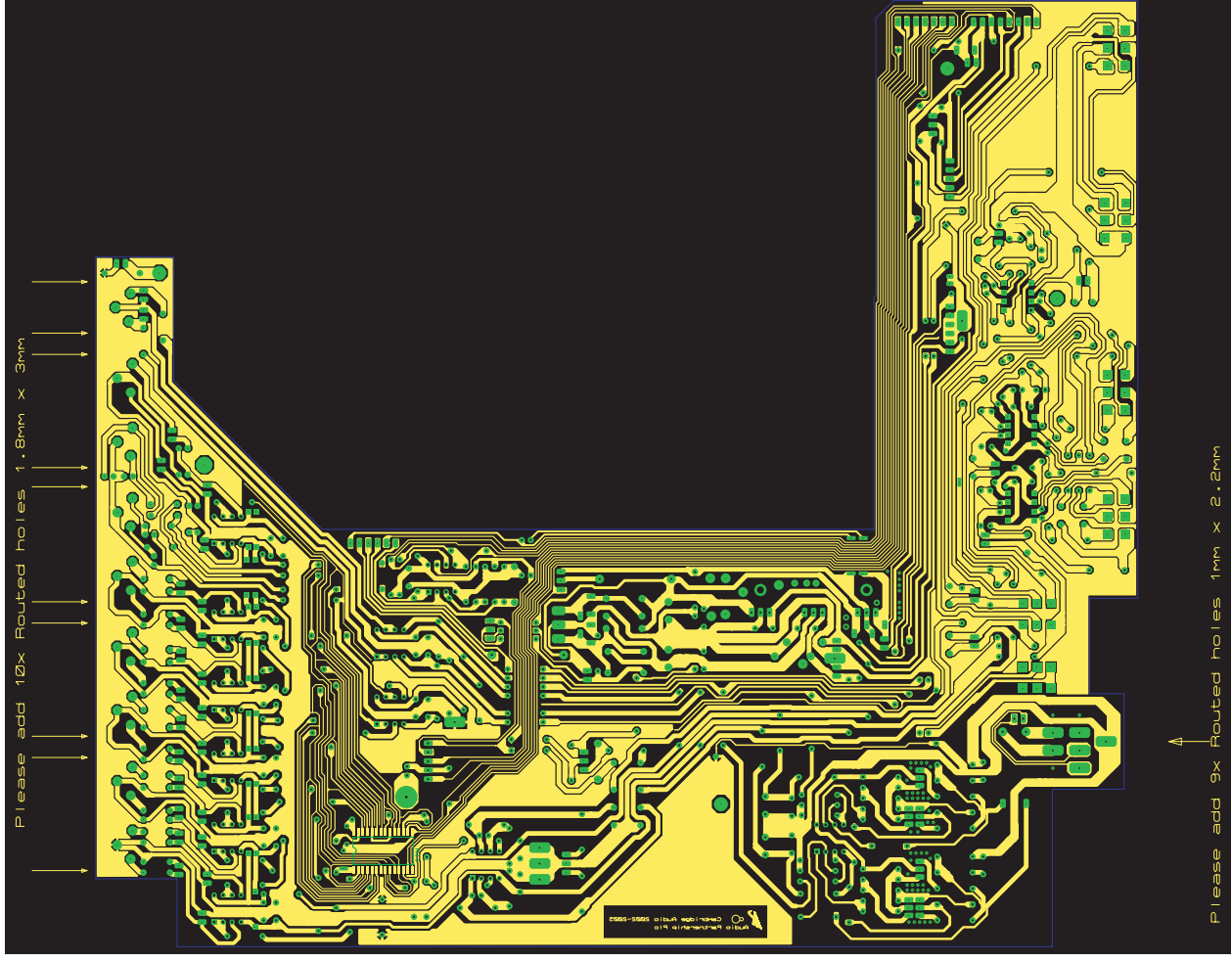

To enhance viewing, please print to A3

API7649/4 Input PCB Board Layout (Bottom Side)

Cambridge Audio Azur 640A V2.0 Amplifier Input PCB Assembly BOM

API7652/5

AP Part No	Value	Description/Type	Factory Part No.	Qty	Component Ident	Notes
	RESISTORS					
	1R	0.25W metal film		4	R1, 3, 6, 8.	
	2R7	0.25W metal film		1	R65	See Input Schematic (Protection Circuitry)
	10R	0.25W metal film		2	R53, 54	
	22R	0.25W metal film		2	R33, 34	
	100R	0.25W metal film		5	R49, 52, 67, 98, 99.	
	180R	0.25W metal film		2	R4, 9	
	360R	0.25W metal film		2	R5, 10	
	560R	0.25W metal film		6	R42, 43, 47, 48, 106, 107	
	910R	0.25W metal film		1	R63	
	1K	0.25W metal film		2	R66, (R123)	See Input Schematic (Tone Control)
	1K1	0.25W metal film		4	R23-26	
	1K5	0.25W metal film		4	R27, 32, (118, 120)	See Input Schematic (Headphone Driver)
	1K8	0.25W metal film		6	R58, 59, 102-105.	
	2K2	0.25W metal film		8	R17-19, 21, 35-38	
	2K7	0.25W metal film		2	R41, 46	
	3K	0.25W metal film		4	R28, 30, R119, (R121)	See Input Schematic (Headphone Driver)
	3K3	0.25W metal film		2	R40, 45	
	3K6	0.25W metal film		2	R60, 61	
	4K7	0.25W metal film		8	R20, 22, 55, 56, 69, 71, 114, 117	
	5K6	0.25W metal film		4	R2, 7, 39, 44	
	10K	0.25W metal film		5	R64, 70, 115, 116, (122)	See Input Schematic (Tone Control)
	22K	0.25W metal film		2	R29, 31	
	100K	0.25W metal film		1	R68	
	150K	0.25W metal film		4	R13-16	
	470K	0.25W metal film		2	R100, 101	
	1k	0.125W metal film		12	R72, 78, 80, 82, 84, 86, 88, 90, 92, 94, 97, 109.	See Input Schematic (Buffers and Switches)
	220R	0.125W metal film		6	R74-77, 111, 112.	
	47K	0.125W metal film		12	R73, 79, 81, 83, 85, 87, 89, 91, 93, 95, 96, 110,	
	10R	2W Carbon		2	R11, 12	See Input Schematic (Headphone Driver)
	220R	2W Carbon		2	R57, 108	
	CAPACITORS					
	10pF 50V	NP0 Ceramic	1181-100042-000	8	C8, 13, 18, 23, 90, 93, 99, 106.	
	100pF 50V	NP0 Ceramic	1181-101042-000	18	C46, 48, 50, 53, 54, 57, 58, 61, 62, 65, 66, 77-80, 83, 84, 85	
	1nF 50V	Ceramic	1100-102043-000	1	C87	
	100nF 50V	Ceramic	1100-104043-000	6	C25, 27, 43, 88, 89, 108	
	100nF 100V	Monolithic Ceramic	1106-104064-001	3	C35, 36, 37.	
	1.5nF 63V	Polyester film		2	C19, 20	
	10nF 63V	Polyester film	1117-103052-000	2	C1, 2	
	47nF 63V	Polyester film	1117-473053-000	30	C9, 10, 14, 16, 29-31, 34, 39, 40, 41, 42, 44, 45, 67-76, 91, 92, 95, 96, 102, 103	
	680nF 63V	Polyester film		2	C21, 22	
	10nF 63V	Polypropylene film		6	C3, 6, 12, 24, 100, 105	
	10uF 16V	Non Polarised Electrolytic	1105-100013-000	14	C47, 49, 51, 52, 55, 56, 59, 60, 63, 64, 81, 82, 101, 104	
	47uF 16V	Non Polarised Electrolytic		4	C4, 5, 7, 11,	
	1uF 25V	Polarised Electrolytic	1102-107024-000	1	C38	
	47uF 16V	Polarised Electrolytic	1102-470014-000	1	C26	
	100uF 16V	Polarised Electrolytic	1102-101014-000	1	C107.	
	100uF 25V	Polarised Electrolytic	1102-101024-000	2	C15, 17	

Note: resistors, capacitors and other 'generic' electronics components are not usually stocked by the manufacturer. Please obtain these locally.

Cambridge Audio Azur 640A V2.0 Amplifier Input PCB Assembly BOM

API7652/5

AP Part No	Value	Description/Type	Factory Part No.	Qty	Component Ident	Notes
	100uF 25V	105 degree Polarised Electrolytic		2	C28, 98.	
	470uF 25V	Polarised Electrolytic		2	C94, 97	
	1000uF 35V	Polarised Electrolytic	1102-102034-000	2	C32, 33	
TRANSISTORS						
	BD140	PNP Low power		2	Q1, 4	Q1 and Q2 must be thermally coupled and Q4 and Q5 must be thermally coupled, please see misc section for parts
	BD139	NPN Low power		4	Q2, 3, 5, 6,	Q1 and Q2 must be thermally coupled and Q4 and Q5 must be thermally coupled, please see misc section for parts
PY219	BC327-25	PNP Signal	1301-327000-100	1	Q7	
PY214	BC337-25	NPN Signal	1300-337000-100	1	Q8	
		NPN Darlington	1300-140000-100	1	Q9	See Input Schematic (Tone Control)
DIODES						
PY319	1N4004	Rectifier	1401-140040-000	9	D1-6,(D8, D9, D10)	See Input Schematic (Power Supply & Tone Control)
PY759	1N4148	Signal	1401-141480-000	1	D7	
INTEGRATED CIRCUITS						
PY108		NE5532N	4155-320052-900	13	U1, 5-7, 9, 10, 12-18	
		L7915CV		1	U2	
		L7805		1	U3	
		L7815CV		1	U4	
PY539		LM393	4139-300052-600	1	U8	
PY476		TC9163AF	4191-630103-000	1	U11	
POTS						
PY1013	20kA	Motorised Dual Volume Pot	1062-003511E110	1	VR3	High Torque
	MN20k	Dual Balance Pot	1062-003518E160	1	VR4	High Torque
	5kB	Dual Linear Pot	1062-002518E130	2	VR1, 2	High Torque
SWITCH						
PY045		2P2T Push Switch	2402-020200-010	2	SW1, 2	
MISCELLANEOUS						
	LINK10mm	24SWG Tinned Copper Wire		70	LK1-4, 13, 22, 23, 26, 28-31, 44, 47, 63, 64, 66, 67, 70, 71, 74, 75, 78, 79, 82, 83, 86, 88, 98, 14-16,24, 25, 27, 38-40, 45, 46, 54, 55, 57, 58, 61, 62, 65, 68, 69, 72, 73, 76, 77, 80, 81, 84, 85, 87, 92-95, 97, 101-103,(104,105,106,107)	See Input Schematic (Power Supply & Tone Control)
	LINK15mm	24SWG Tinned Copper Wire		39	LK5, 8, 9, 18-21, 33, 37, 43, 49, 51, 53, 56, 89-91, 99, 100, 6, 7, 10-12, 17, 32, 34-36, 41, 42, 48, 50, 52, 59, 60, 96,(108,109)	See Input Schematic (Tone Control)
PY584		5V Relay	4050-000005-002	1	RL1	See Input Schematic (Tone Control)

Note: resistors, capacitors and other 'generic' electronics components are not usually stocked by the manufacturer. Please obtain these locally.

Cambridge Audio Azur 640A V2.0 Amplifier

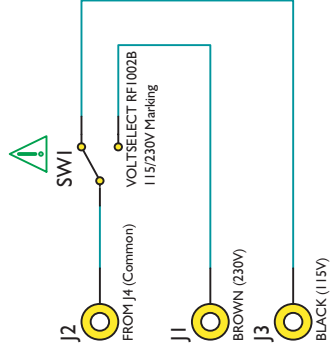

Cambridge Audio Azur 640A V2.0 Amplifier

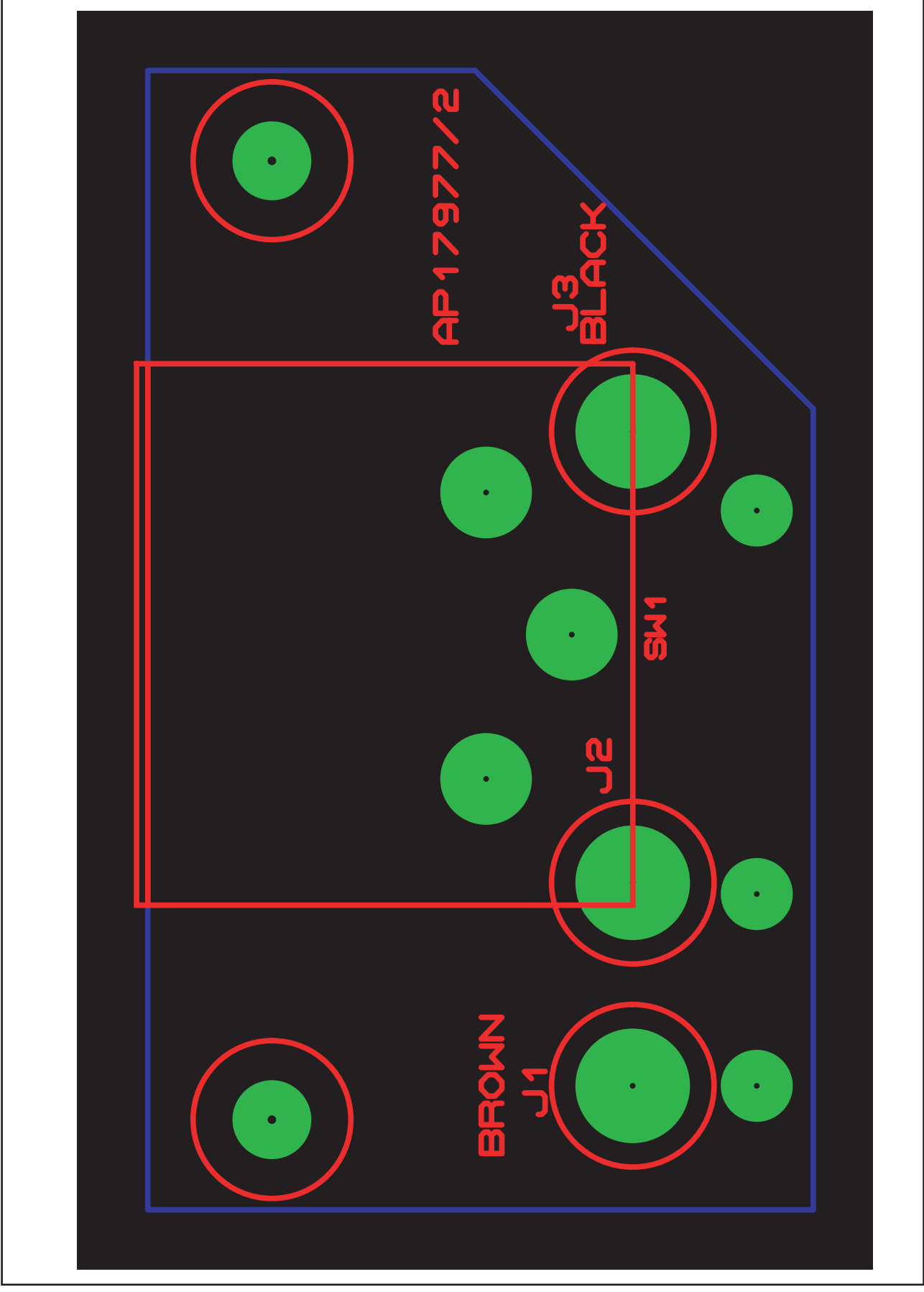

Cambridge Audio Azur 640A V2.0 Amplifier

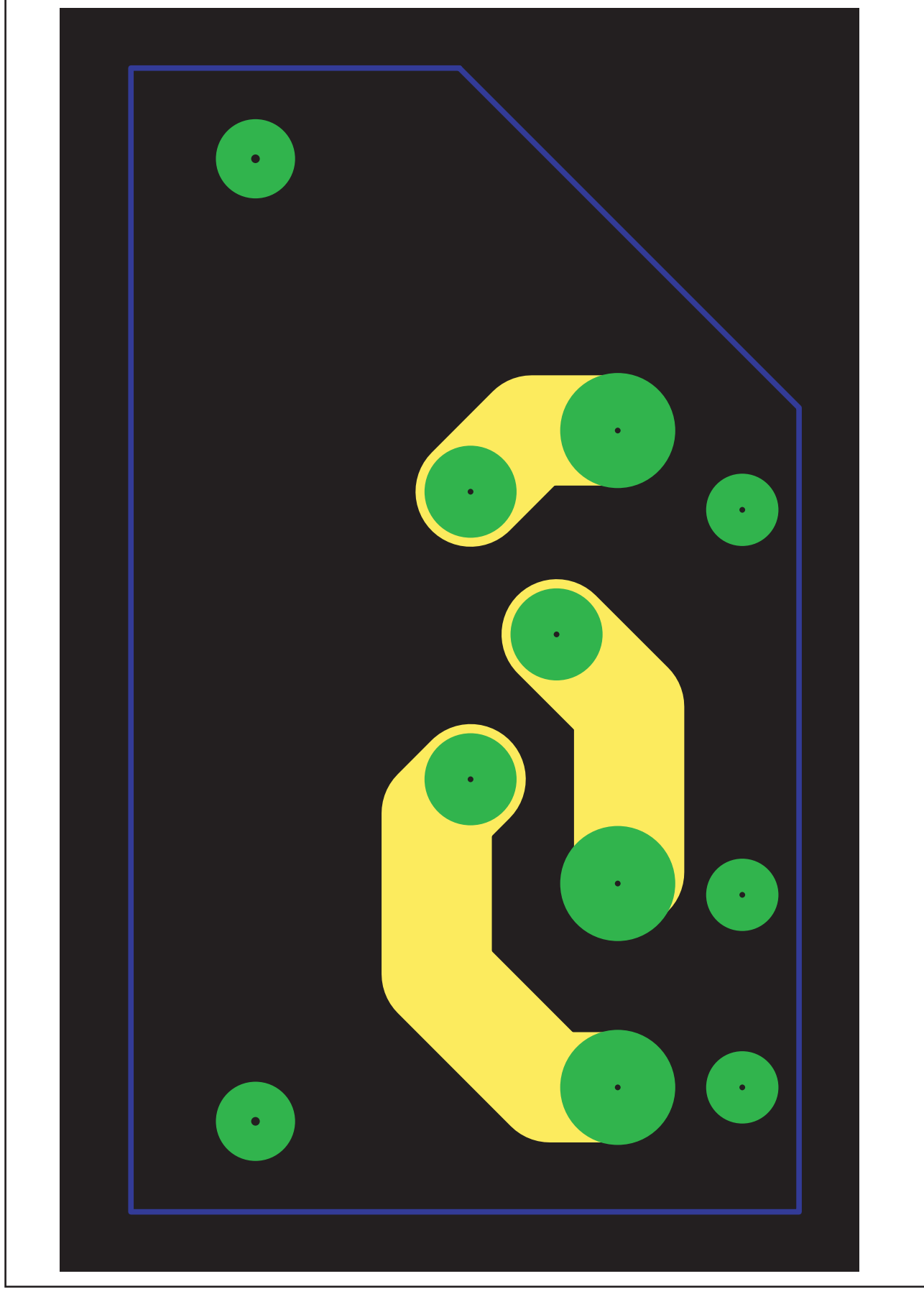

To enhance viewing, please print to **A3**
AP17977/2 Voltage Select Switch PCB Layout (Bottom Side)

Cambridge Audio Azur 640A V2 Voltage Selector PCB Assembly BOM**API7980/I**

Value	Description/Type	Qty	Component Ident	Factory Part Number	Notes
CONNECTORS					
RF1002B	Voltage Selector	1	SW1	2406-010200-000	

Note: resistors, capacitors and 'other' electronic components are not usually stocked by the manufacturer. Please obtain these locally.

Cambridge Audio Azur 640A V2.0 Amplifier

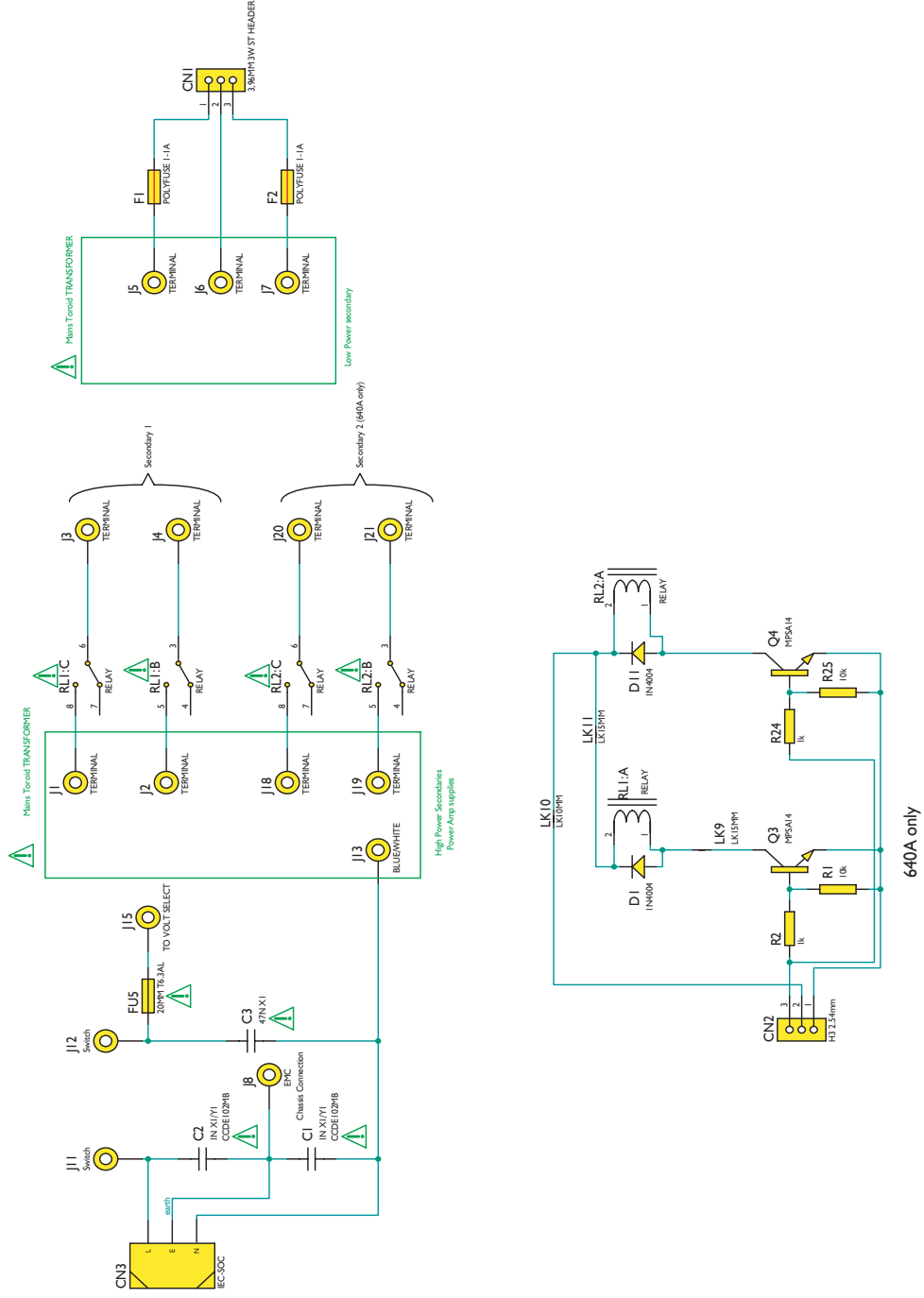

Cambridge Audio Azur 640A V2.0 Amplifier

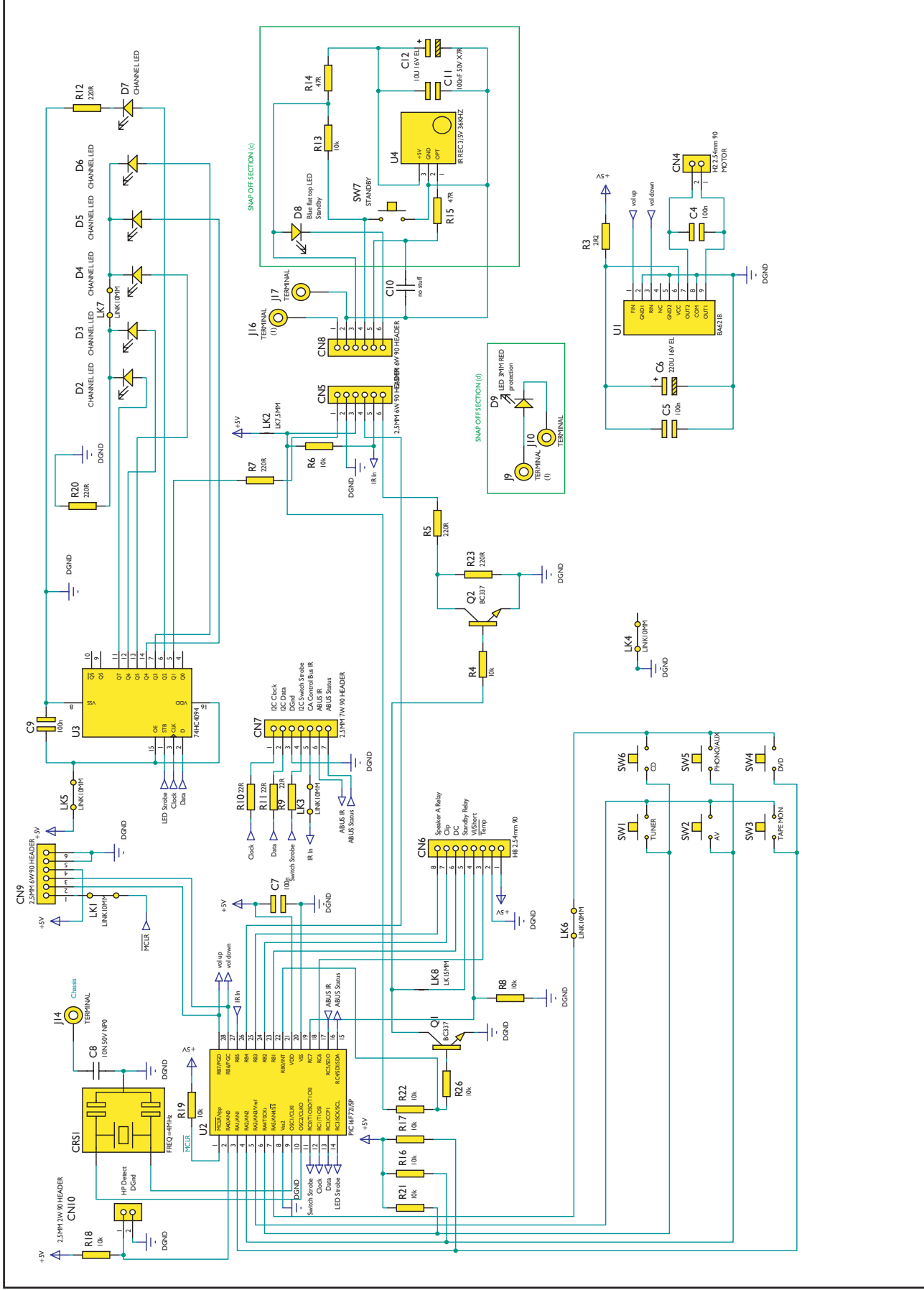

Cambridge Audio Azur 640A V2.0 Amplifier

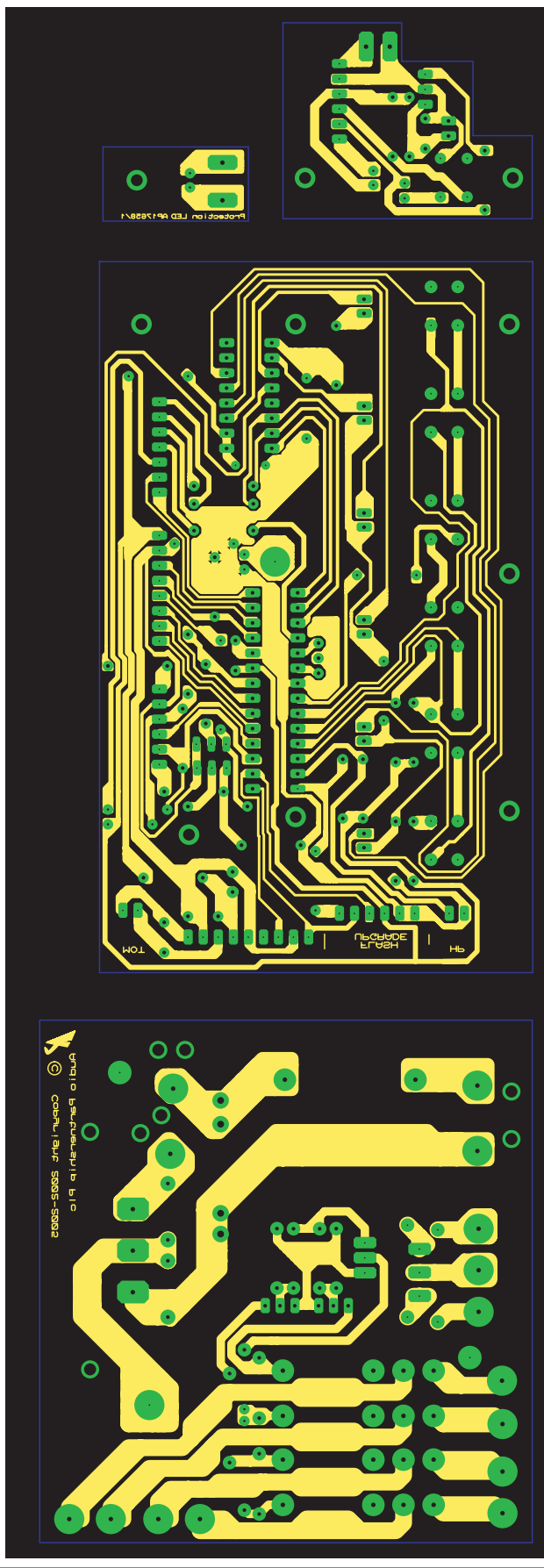

Cambridge Audio Azur 640A Front Panel and Mains PCB Assembly BOM
API7660/I

AP Part No.	Value	Description	Factory Part No.	Qty	Component Ident	Notes
RESISTORS						
	220R	0.25W metal film		5	R5, 7, 12, 20, 23	
	10K	0.25W metal film		540A 12 640A 13	R1, 4, 6, 8, 13, 16-19, 21, 22, 25, 26	
	22R	0.25W metal film		3	R9-11	
	47R	0.25W metal film		2	R14, 15	
	2R2	0.25W metal film		1	R3	
	1K	0.25W metal film		540A 1 640A 2	R2, 24	
CAPACITORS						
	100nF	50V Ceramic	1100-104044-000	5	C4, 5, 7, 9, 11	
	47nF	Mains Rated X1		1	C3	Mains Suppression
	1nF	Mains Rated X1/Y1		2	C1, 2	Mains Suppression
	10nF	50V Ceramic	1100-104043-000	1	C8	
	10uF	16V Electrolytic	1102-100014-000	1	C12	
	220uF	16V Electrolytic	1102-221014-000	1	C6	
TRANSISTORS						
	MPSA14	NPN Darlington Transistor	1300-140000-100	540A 1 640A 2	Q3, Q4	540A fit Q4 only
PY214	BC337-25	NPN Transistor	1300-337000-100	2	Q1, 2	
DIODES						
PY064	Blue	LED	3100-000030-003	7	D2-8	
	Red	LED	3100-000000-003	1	D9	
PY319	1N4004	Rectifier Diode		540A 1 640A 2	D1, 11	540A fit D11 only
INTEGRATED CIRCUITS						
PY635	PIC16F721/SP	Flash PIC micro	4116-720054-200	1	U2	U2 must be programmed with API8951/I software (file name: 640AV2.hex) Request from UK Office
PY260	BA6218	Motor Drive IC	4162-180002-300	1	U1	
PY524	M74HC4094	Shift Register	4174-409052-600	1	U3	
PY054	3/5V 36KHZ	IR Receiver	3001-183600-001	1	U4	
RELAY						
PY594		8A-250VAC 2P2T	4050-110122-001	540A 1 640A 2	RL1, RL2	540A fit RL2 only
SWITCHES						
PY043		Tact Switch	2400-020200-000	7	SW1-7	
MISCELLANEOUS						
	4MHz	Ceramic Resonator	1602-400002-990	1	CRS1	
	20MM T6.3AL			1	FU5	
	1.1A	Polyfuse		2	F1,2	

Note: resistors, capacitors and other 'generic' components are not usually stocked by the manufacturer. Please obtain these locally.

Cambridge Audio Azur 640A V2.0 Amplifier

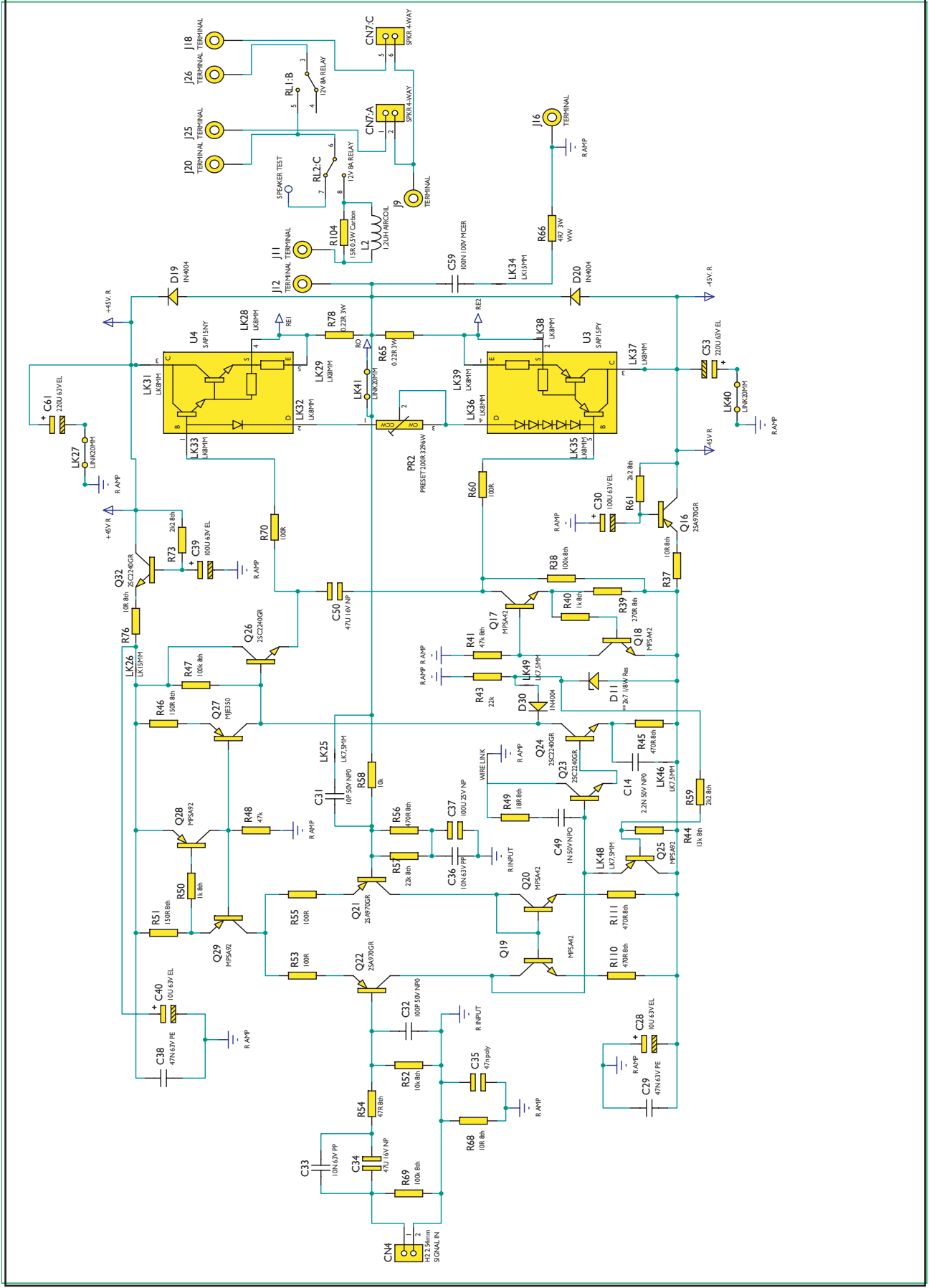

To enhance viewing, please print to A3

API7653/2 Amp PCB Schematic (Right Channel)

Cambridge Audio Azur 640A V2.0 Amplifier

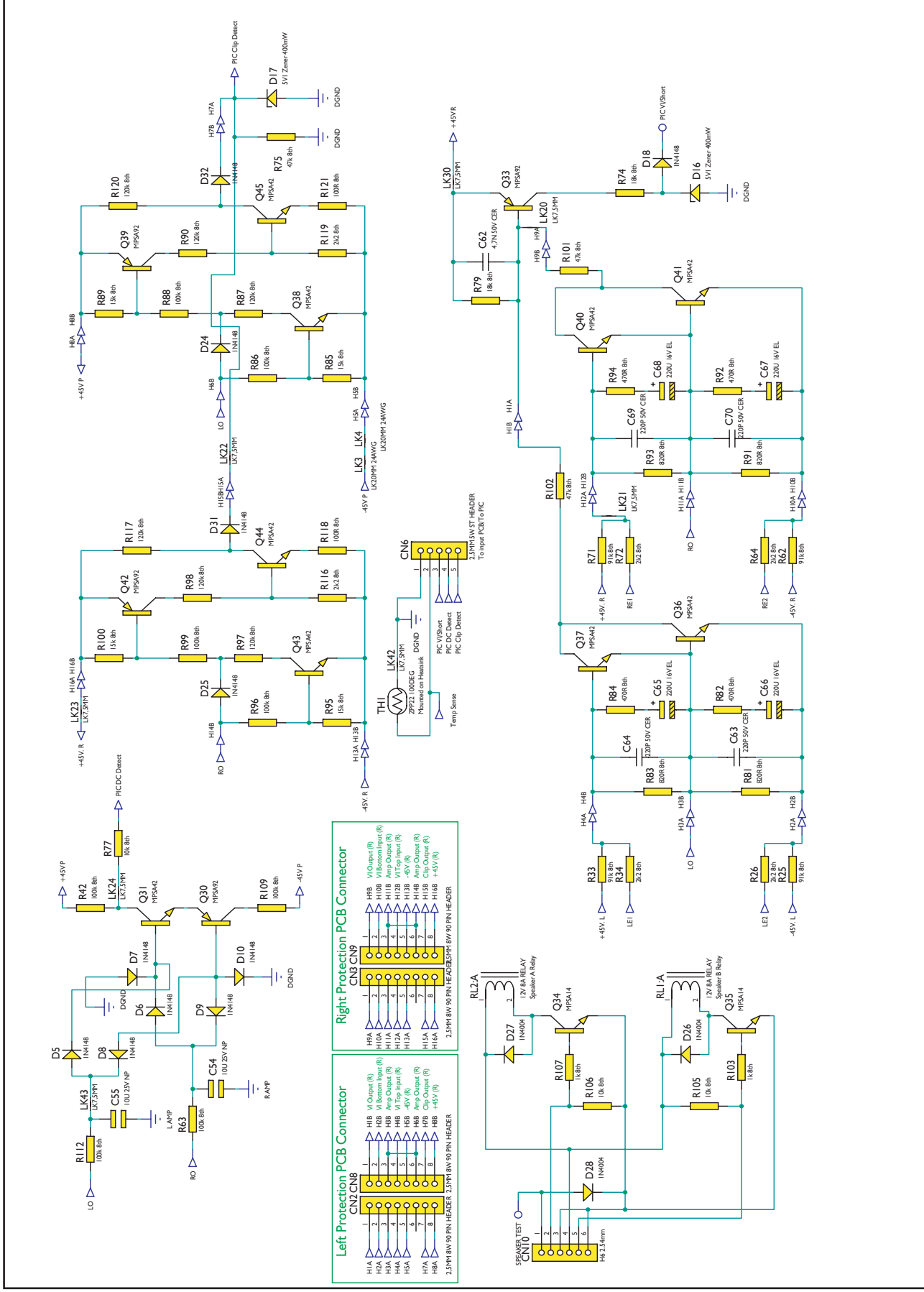

To enhance viewing, please print to A3

API 7653/2 Amp PCB Schematic (Protection)

Cambridge Audio Azur 640A V2.0 Amplifier

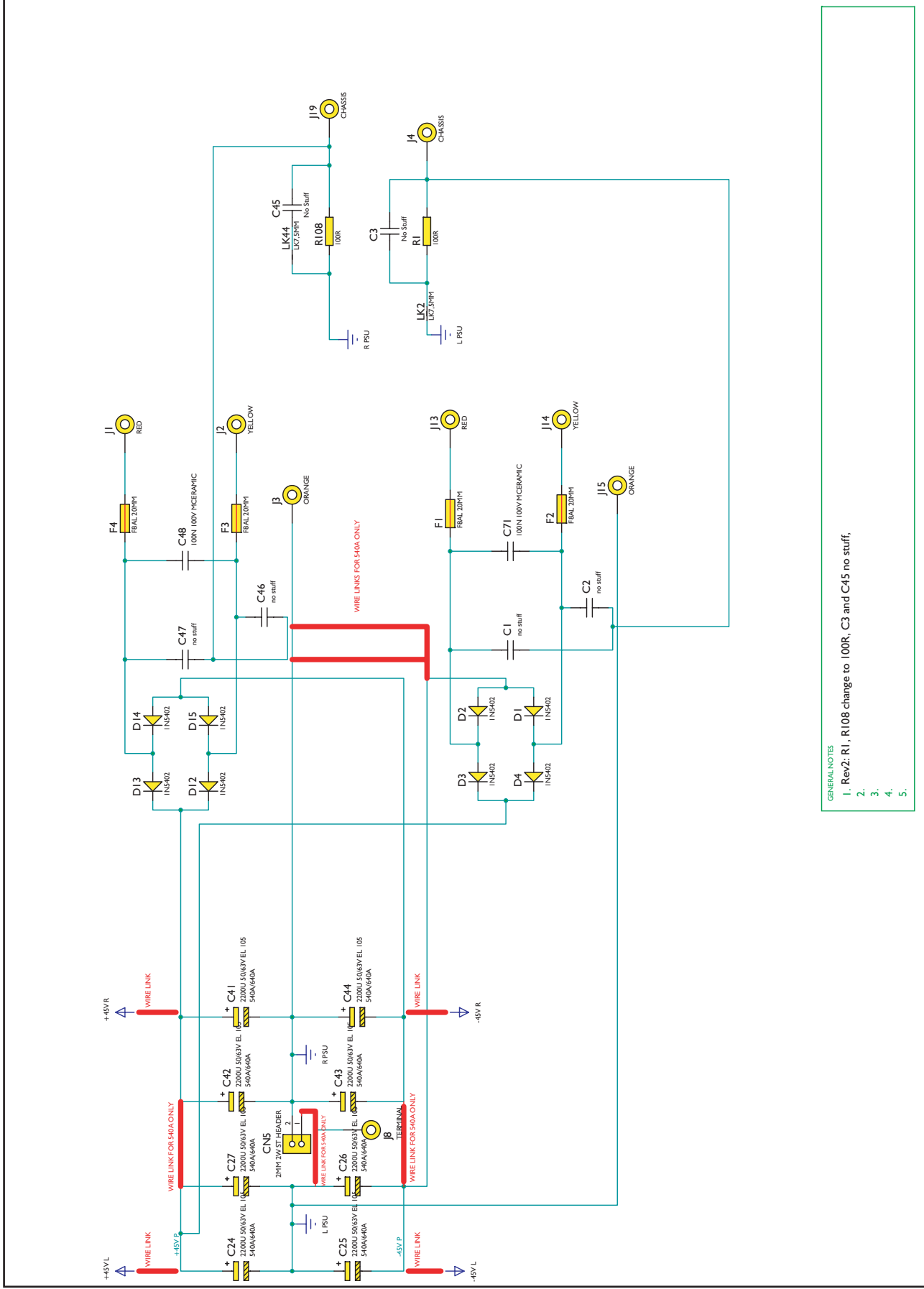

Cambridge Audio Azur 640A V2.0 Amplifier

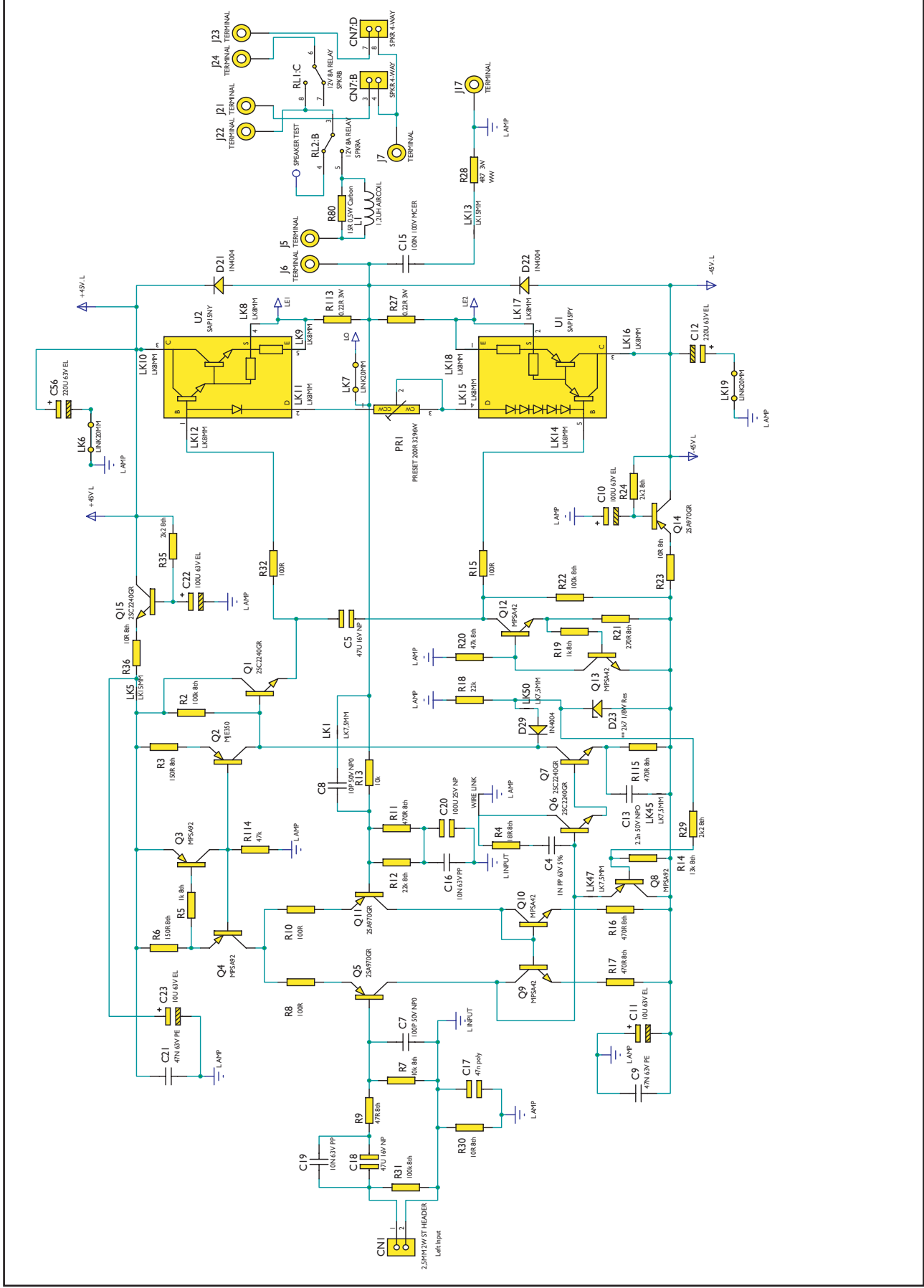

To enhance viewing, please print to A3

API 7653/2 Amp PCB Schematic (Left Channel)

Cambridge Audio Azur 640A V2.0 Amplifier

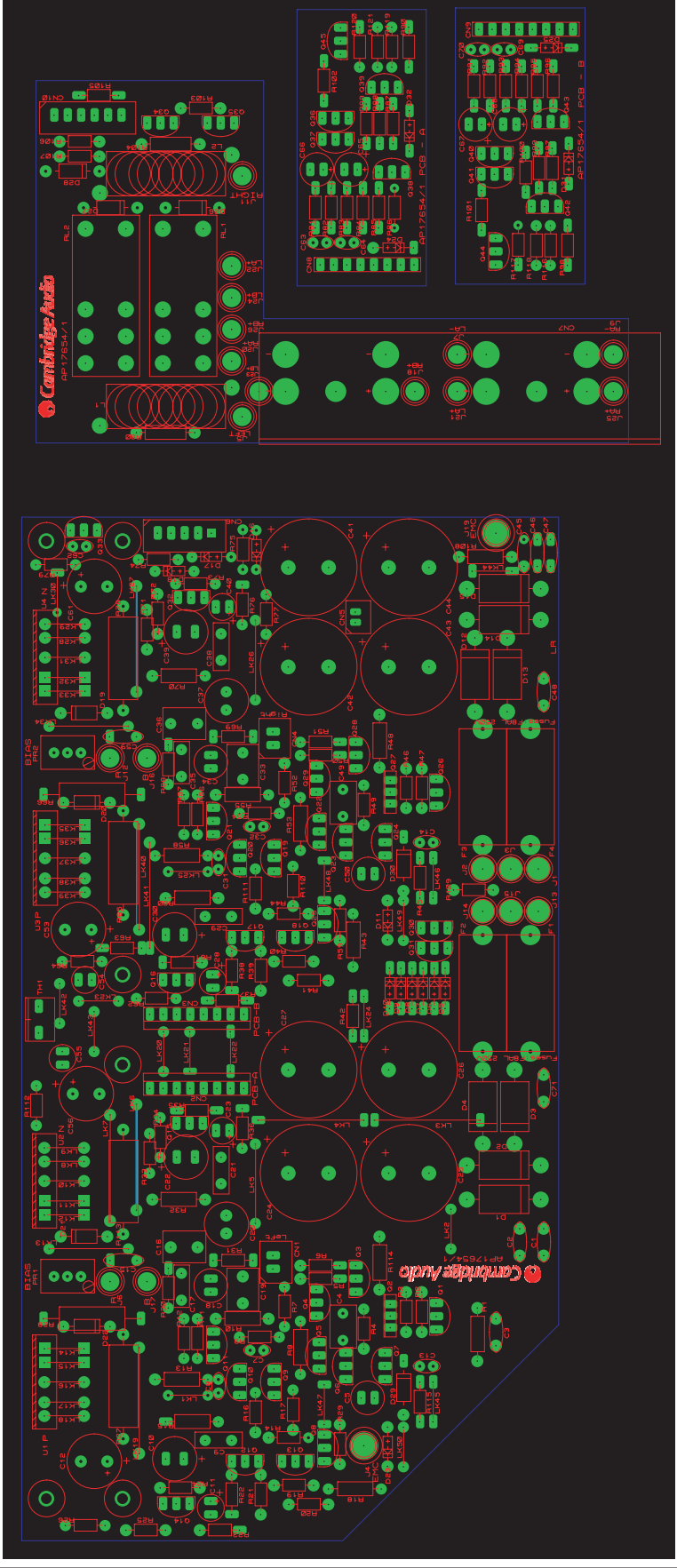

To enhance viewing, please print to A3

API7653/1 Amp PCB Board Layout (Top Side)

Cambridge Audio Azur 640A V2.0 Amplifier

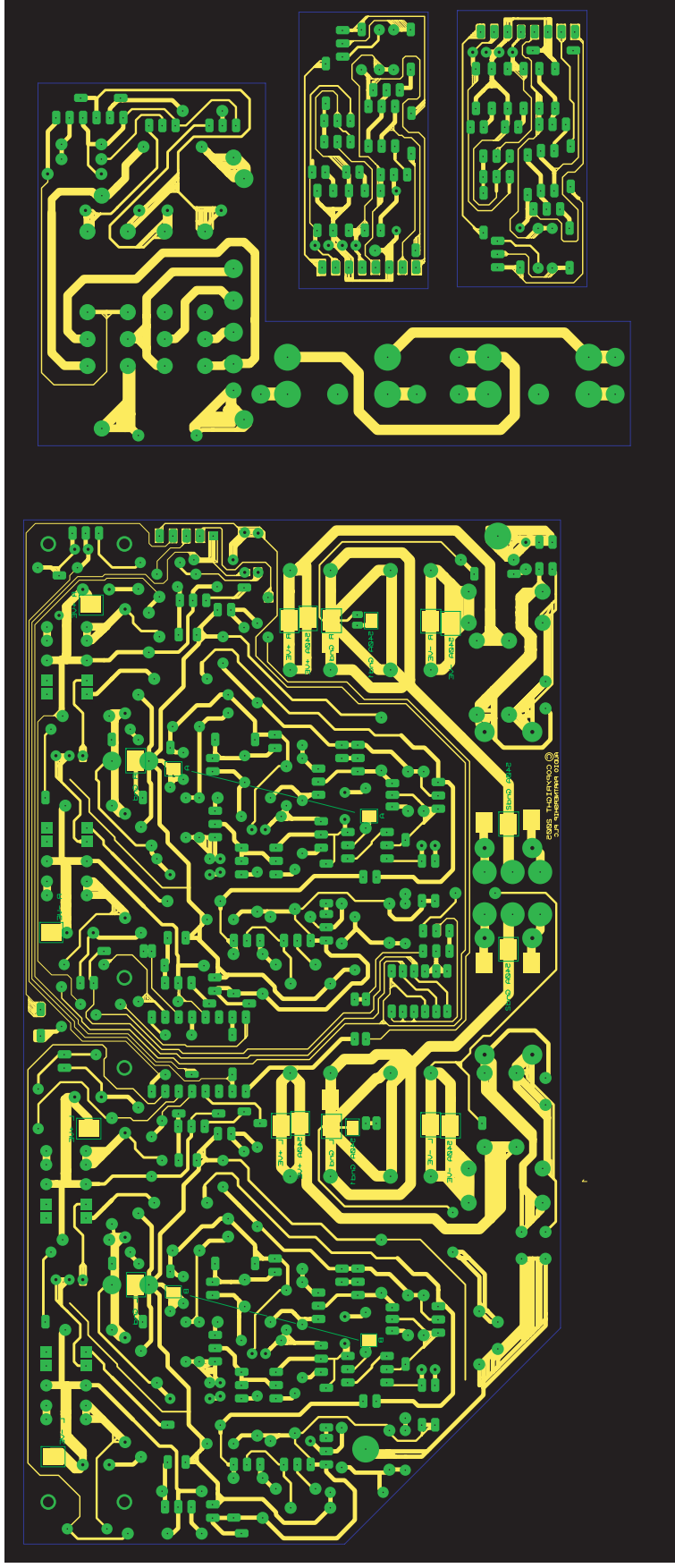

To enhance viewing, please print to A3

AP I7653/1 Amp PCB Board Layout (Bottom Side)

Cambridge Audio Azur 640A V2 Amp PCB Assembly BOM
API7656/2

AP Part No	Value	Description	Reference	Qty	Factory Part No	Comments
	Capacitors					
	100nF 100V	Monolithic Ceramic	C15,C48,C59,C71	540A - 3 640A - 4	1106-104064-001	540A only C48 is not fitted
	1nF 63V	Polypropylene film	C4	1		
	47uF 16V	Non Polarised Electrolytic	C5,C18,C34,C50	4	1105-470014-000	
	47nF 63V	Polyester Film	C9,C21,C29,C38	4	1117-473053-000	
	100pF 50V	NP0 Ceramic	C7,C32	2	1181-101042-000	
	10pF 50V	NP0 Ceramic	C8	1		
	100uF 63V	Polarised Electrolytic	C10,C22,C30,C39	4	1102-101054-000	
	10uF 63V	Polarised Electrlytic	C11,C23,C28,C40	4	1102-100054-000	
	220uF 63V	Polarised Electrolytic	C12,C53,C56,C61	4		
	2.2nF 50V	NP0 Ceramic	C13,C14	2		
	10nF 63V	Polypropylene film	C16,C19,C33,C36	4		
	47nF 63V	Polyester Film	C17,C35	540A only 2		Only fitted for 540A
	100uF 25V	Non Polarised Electrolytic	C20,C37	2	1105-101024-000	
	2200uF 50V	105deg Polarised Electrolytic	C24-C27,C41-C44	540A only 8	1102-222044-001	Screened for CA/63V for 540A (540A only)
	2200uF 63V	105deg Polarised Electrolytic	C24-C27,C41-C44	640A only 8		Screened for CA/63V for 640A (640A only)
	10pF 50V	NP0 Ceramic	C31	1	1181-100042-000	
	1nF 50V	Ceramic	C49	1		
	10uF 25V	Non Polarised Electrolytic	C54,C55	2	1105-100024-000	
	4.7nF 50V	Ceramic	C62	1	1100-472043-000	
	220pF 50V	Ceramic	C63,C64,C69,C70	4	1100-221042-000	
	220uF 16V	Polarised Electrolytic	C65-C68	4	1102-221014-000	
	Diodes					
	1N5402	Rectifier Diode	640A D1-D4, D12-15 540A - D1-4 only	540A - 4 640A - 8		Please stand off pcb by 5mm
	1N4148	Signal	D5-D10,D18,D24,D25,D31,D32	11	1401-141480-000	
	3V9 500mW	Zener	D11,D23	2		
	5V1 500mW	Zener	D16,D17	2		
	1N4004	Rectifier Diode	D19-D22,D26-D30	9	1401-140040-000	
	Fuses					
	F8AL 20MM		640A F1-F4 540A F1,F2	540A - 2 640A - 4		
	Fuse Holders		640A F1-F4 540A F1,F2	540A - 2 640A - 4		
	Inductors					
	24.5T 0.9mm	1.2uH Output Inductor	L1,L2	2	3203-874801-000	
	Ics					
PY016	SAP15PY	PNP Power Transistor	U1,U3	2	1301-150000-700	
PY010	SAP15NY	NPN Power Transistor	U2,U4	2	1300-150000-700	
	Pots					
	200R	3296W Multiturn Preset	PR1,PR2	2		
	Relay					
PY594	12V 8A RELAY		RL1,RL2	2		
	Resistors					

Note: resistors, capacitors and other 'generic' electronic components are not usually stocked by the manufacturer. Please obtain these locally.

Cambridge Audio Azur 640A V2 Amp PCB Assembly BOM

API7656/2

AP Part No	Value	Description	Reference	Qty	Factory Part No	Comments
	100k 8th		R2,R22,R31,R38,R42,R47,R63,R69,R86,R88,R96,R99,R109,R112	14		
	150R 8th		R3,R6,R46,R51	4		
	18R 8th		R4,R49	2		
	1k 8th		R5,R19,R40,R50,R103,R107	6		
	91k 8th		R25,R33,R62,R71	4		
	10k 8th		R7,R52,R77,R105,R106	5		
	47R 8th		R9, R54	2		
	100R		R1,R8,R10,R15,R32,R53,R55,R60,R70,R108	10		
	470R 8th		R11,R16,R17,R45,R56,R82,R84,R92,R94,R110,R111,R115	12		
	120k 8th		R87,R90,R97,R98,R117,R120	6		
	22k 8th		R12,R57	2		
	10k		R13,R58	2		
	13k 8th		R14,R44	2		
	100R 8th		R118, R121	2		
	22k		R18,R43	2		
	2k7 8th		D11,D23	2		
	47k 8th		R20,R41,R75,R101,R102	5		
	270R 8th		R21,R39	2		
	10R 8th		R23,R30,R36,R37,R68,R76	540A 6 640A 4		640A has R30 and R68 linked out 540A has R30 and R68 fitted
	2k2 8th		R24,R26,R29,R34,R35,R59,R61,R64,R72,R73, R116, R119	12		
	0.22R 3W		R27,R65,R78,R113	4		
	4R7 3W		R28,R66	2		
	47k		R48,R114	2		
	15k 8th		R85,R89,R95,R100	4		
	18k 8th		R74,R79	4		
	15R	0.5W Carbon film	R80,R104	2		
	820R 8th		R81,R83,R91,R93	4		
	Transistors					
PY910	2SC2240GR	NPN Low Noise	Q1,Q6,Q7,Q15,Q23,Q24,Q26,Q32	8		
PY018	MJE350	PNP Low Power	Q2,Q27	2	1301-350000-200	
PY220	MPSA92	PNP High Voltage	Q3,Q4,Q8,Q25,Q28-Q30,Q33,Q39,Q42	10	1301-920000-100	
	2SA970GR	PNP Low Noise	Q5,Q11,Q14,Q16,Q21,Q22	6	1301-970000-100	

Note: resistors, capacitors and other 'generic' electronic components are not usually stocked by the manufacturer. Please obtain these locally.

Cambridge Audio Azur 640A V2 Amp PCB Assembly BOM**API7656/2**

AP Part No	Value	Description	Reference	Qty	Factory Part No	Comments
PY537	MPSA42	NPN High Voltage	Q9,Q10,Q12,Q13,Q17-Q20,Q31,Q36-Q38,Q40,Q41,Q43-Q45	17	1300-420000-100	
	MPSA14	NPN Darlington	Q34,Q35	2	1300-140000-100	

Note: resistors, capacitors and other 'generic' electronic components are not usually stocked by the manufacturer. Please obtain these locally.

Cambridge Audio Azur 640A V2.0 Amplifier

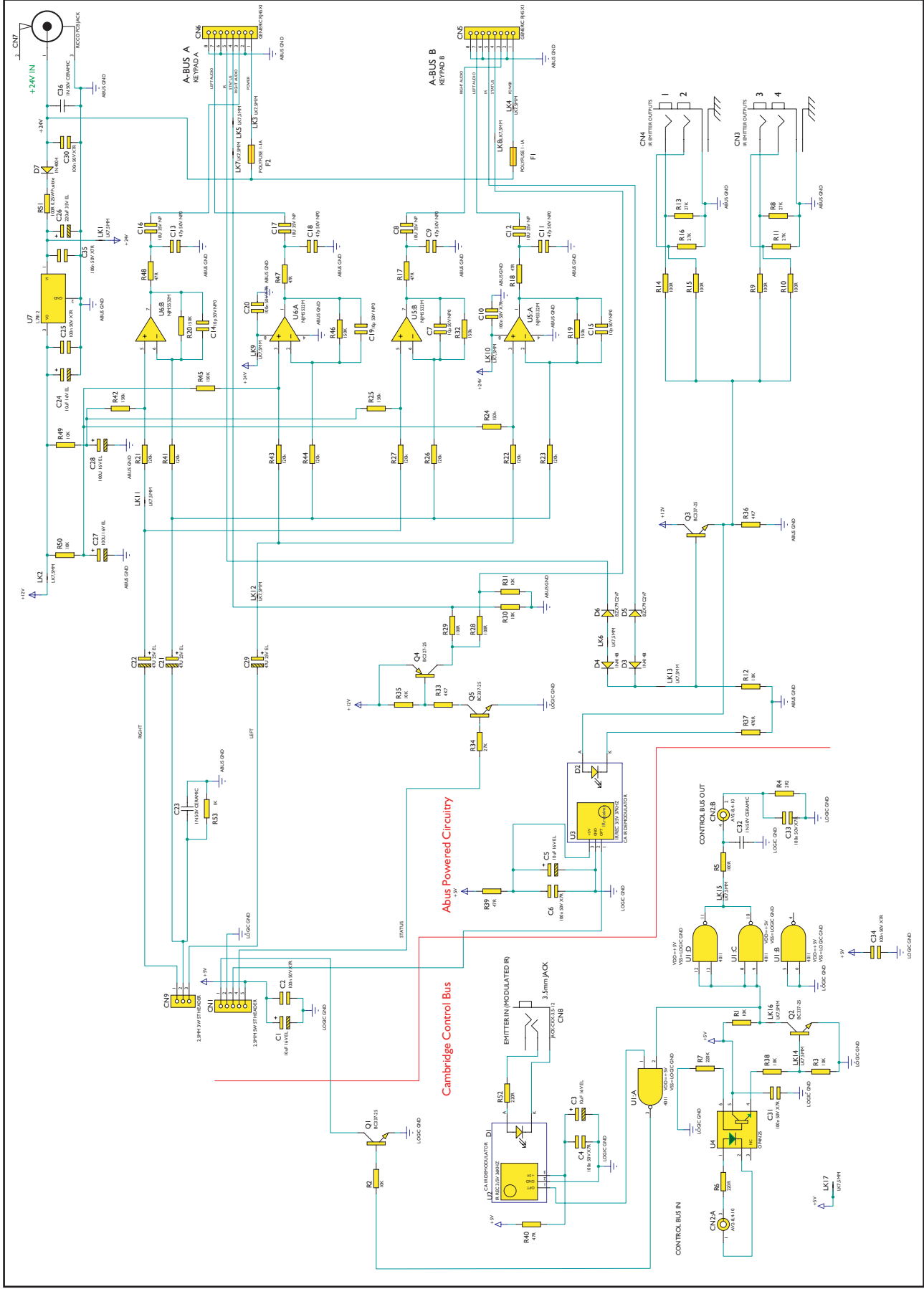

To enhance viewing, please print to A3

API 7708/4 Abus Module PCB Schematic

Cambridge Audio Azur 640A V2.0 Amplifier

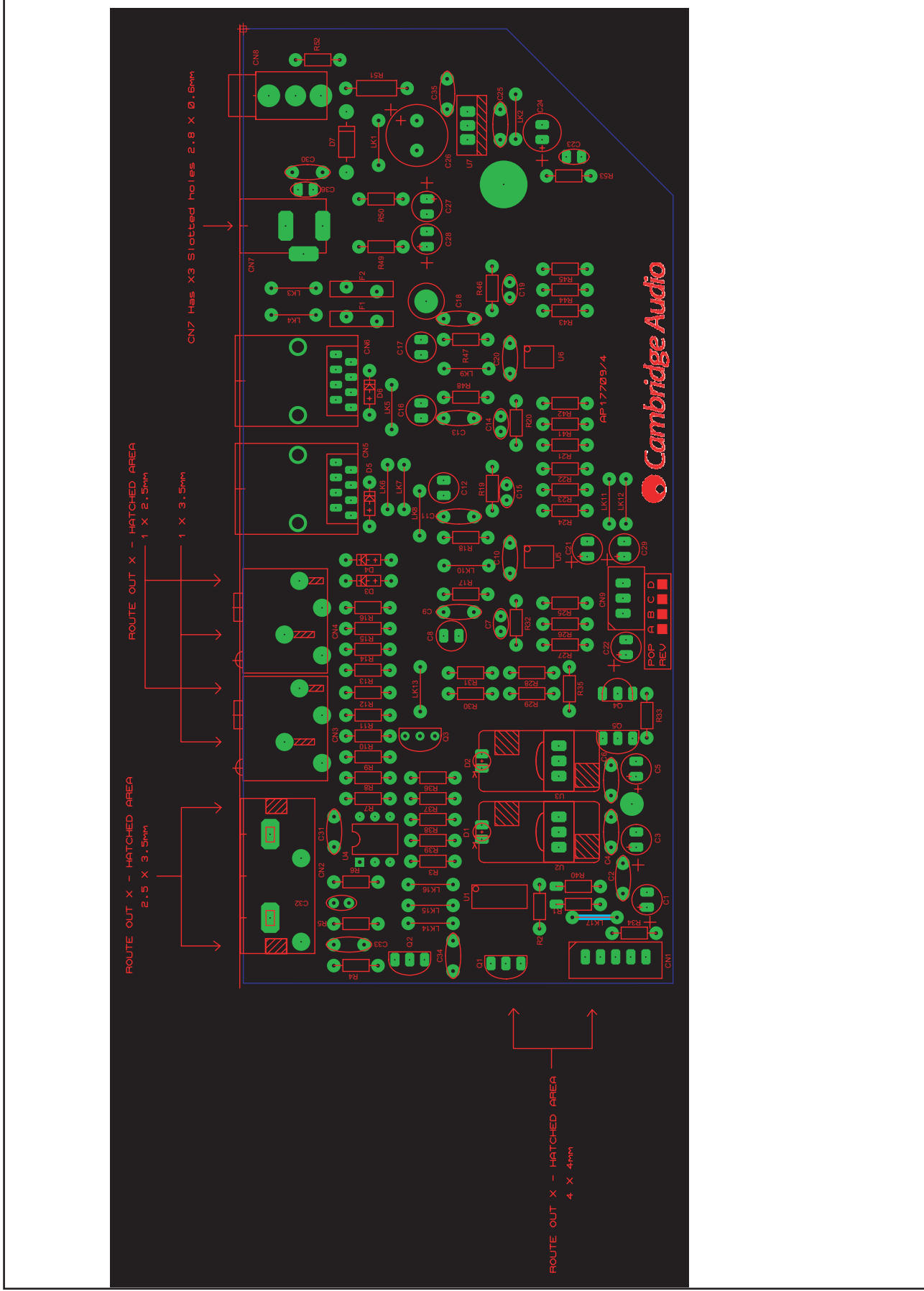

To enhance viewing, please print to A3

API7708/4 Abus Module PCB Layout (Top Side)

Cambridge Audio Azur 640A V2.0 Amplifier

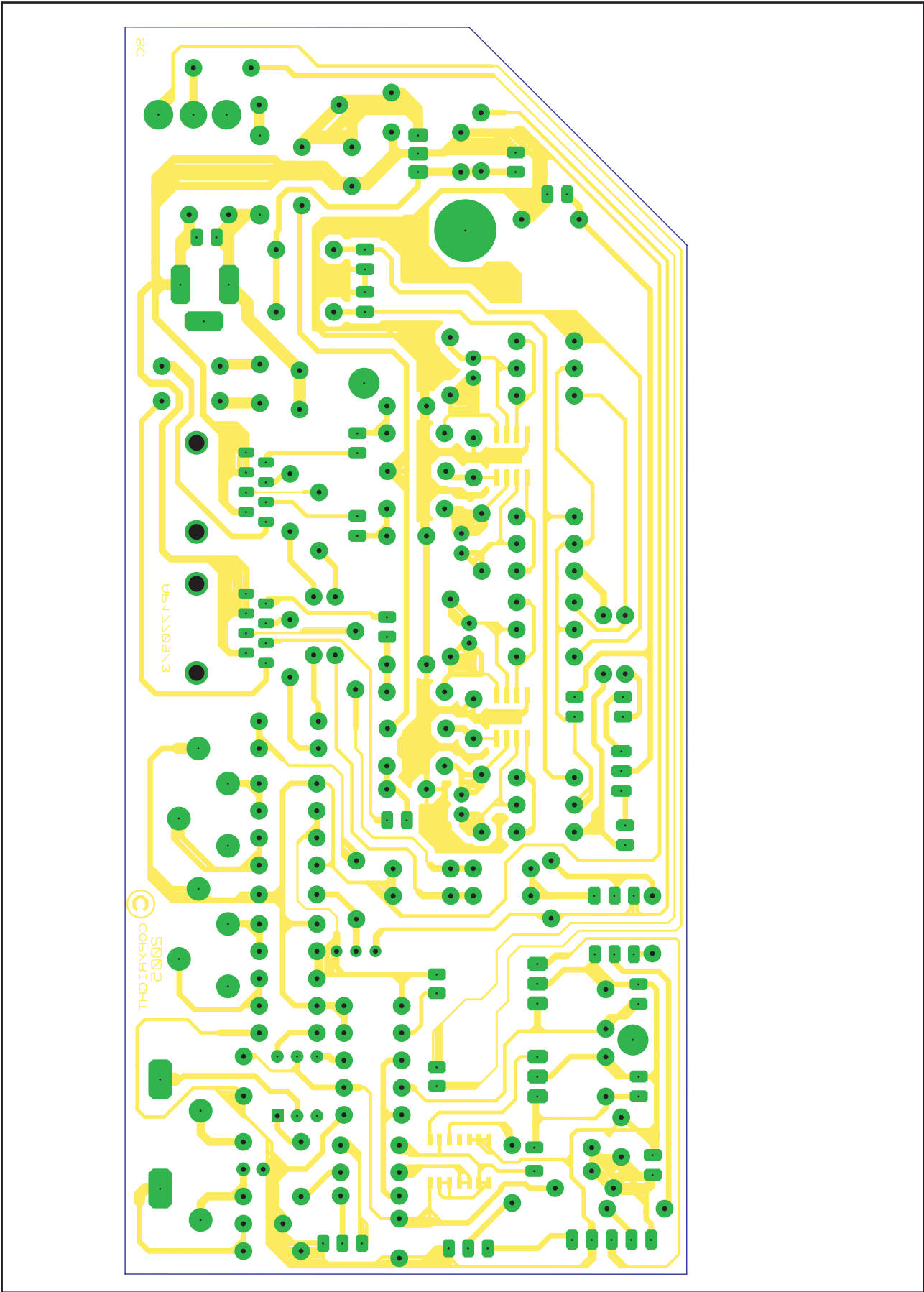

To enhance viewing, please print to A3

API 7708/4 Abus Module PCB Layout (Bottom Side)

Cambridge Audio Azur 640A V2 A-Bus PCB BOM

API7711/1

AP Part No	Value	Description	Factory Part No	Qty	Component Ident	NOTES
RESISTORS						
	2R2	0.125W metal film		1	R4	
	47R	0.125W metal film		6	R17, 18, 39, 40, 47, 48	
	100R	0.125W metal film		8	R5, 9, 10, 14, 15, 28, 29	
	220R	0.125W metal film		2	R6, 52	
	470R	0.125W metal film		1	R37	
	1K	0.125W metal film		1	R53	
	4K7	0.125W metal film		2	R33, 36	
	10K	0.125W metal film		10	R1, 2, 3, 12, 30, 31, 35, 38, 49, 50	
	27k	0.125W metal film		5	R8, 11, 13, 16, 34	
	120K	0.125W metal film		8	R21, 22, 23, 26, 27, 41, 43, 44	
	150K	0.125W metal film		8	R19, 20, 24, 25, 32, 42, 45, 46	
	220K	0.125W metal film		1	R7	
	100R	0.33W Fusible metal film		1	R51	Resistor must be raised off the PCB by 5mm
CAPACITORS						
	10pF 50V	NP0 Ceramic	1181-100042-000	4	C7, 14, 15, 19	
	47pF 50V	NP0 Ceramic	1181-470042-000	4	C9, 11, 13, 18.	
	1nF 50V	Ceramic	1100-102043-000	3	C23, 32, 36	
	100nF 50V	Ceramic	1100-104043-000	11	C2, 4, 6, 10, 20, 25, 30, 31, 33, 34, 35	
	10uF 16V	Polarised Electrolytic	1102-100014-000	4	C1, 3, 5, 24	
	47uF 25V	Polarised Electrolytic	1102-470024-000	3	C21, 22, 29	
	100U 16V	Polarised Electrolytic	1102-101014-000	2	C27, 28	
	220uF 35V	Polarised Electrolytic	1102-221034-001	1	C26	
	10U NP 35V	NP Electrolytic		4	C8, 12, 16, 17	
TRANSISTORS						
PY214	BC337-25	NPN Signal	1300-337000-100	4	Q1, 2, 3, 5	
PY219	BC327-25	PNP Signal	1301-327000-100	1	Q4	
DIODES						
PY962	Red LED			2	D1, 2	
PY759	1N4148		1401-141480-000	2	D3, 4	
	BZX79C2V7		1402-270001-201	2	D5, 6	
	1N4004		1401-140040-000	1	D7	
INTEGRATED CIRCUITS						
	4011	Quad 2 Input NAND Gate		1	U1	
PY755		36kHz IR Receiver	3001-348360-000	1	U2	
PY1007		37kHz IR Receiver	3001-348370-000	1	U3	
PD025		Opto Isolator	4142-500050-001	1	U4	
	NJM5532M	Op amp	4155-320101-600	2	U5, 6	
	L7812	12V 1A Regulator	4178-120302-600	1	U7	
FUSES						
	POLYFUSE 1.1A		4030-301100-001	2	F1, 2	

Note: resistors, capacitors and other 'generic' electronic components are not usually stocked by the manufacturer. Please obtain these locally.

Cambridge Audio Azur 640A V2.0 Amplifier IC Pin Layout Details

Input PCB

BDI40 (Q1 & Q4)

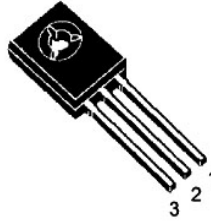

BDI39 (Q2, Q3, Q5 & Q6)

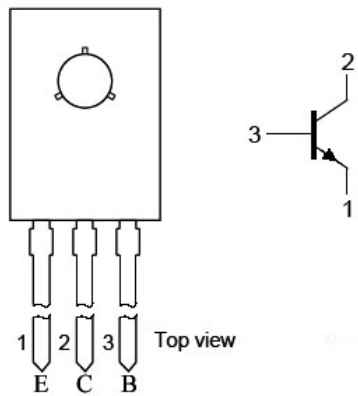

BC327 (Q7)

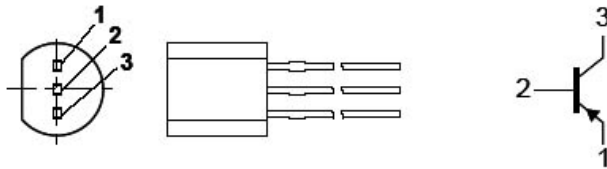

BC337 (Q8)

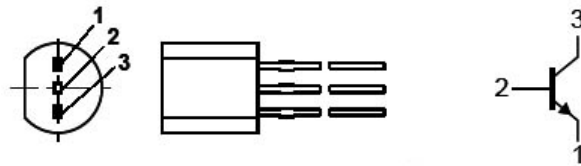

MPSA14 (Q9)

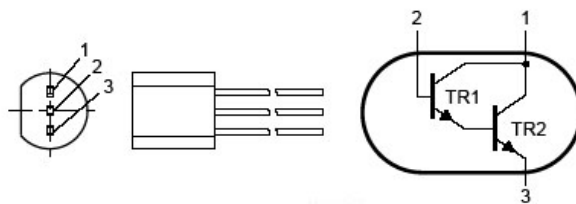

NE5532 (U1, U5, U6, U7, U9, U10, U12, U13, U14, U15, U16, U17 & U18)

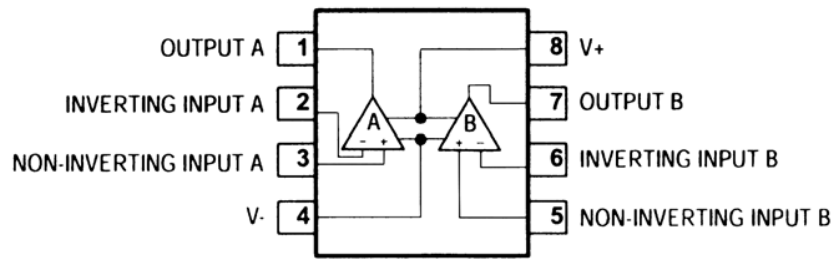

7915 (U2)

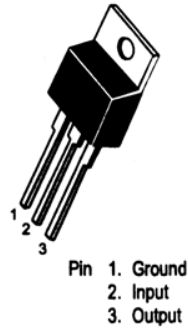

7805 (U3)

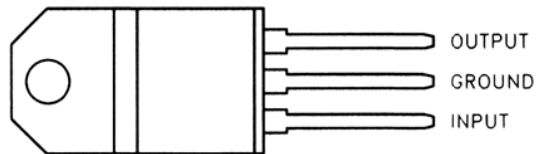

7815 (U4)

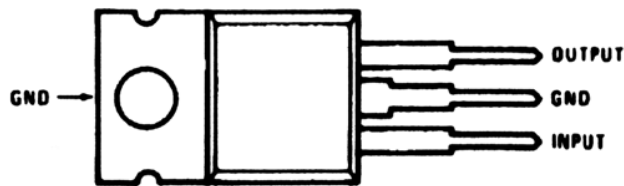

LM393 (U8)

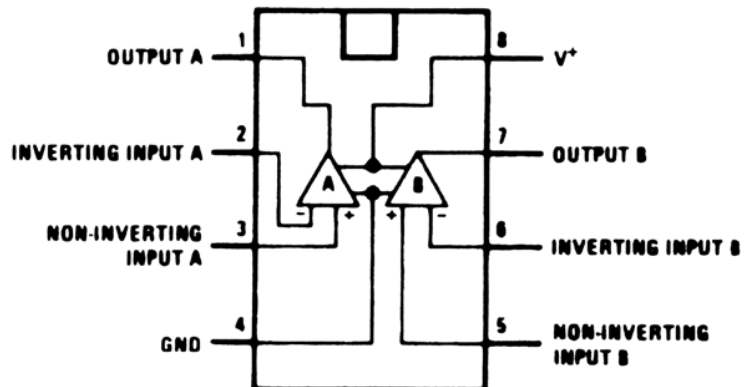

TC9163AF (U11)

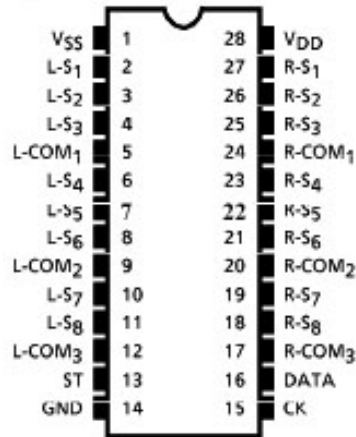

Power Amp PCB

SAP15PY (U1 & U3)

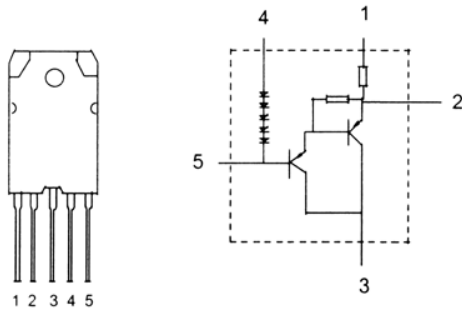

SAP15NY (U2 & U4)

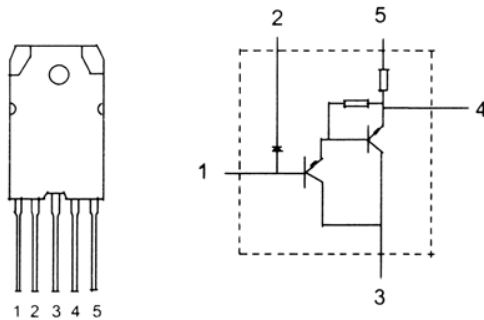

2SC2240GR (Q1, Q6, Q7, Q15, Q23, Q24, Q26 & Q32)

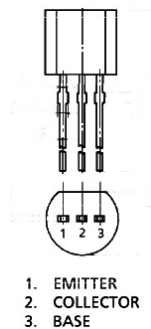

MJE350 (Q2 & Q27)

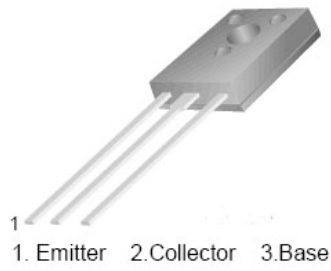

MPSA92 (Q3, Q4, Q8, Q25, Q28, Q29, Q30, Q33, Q39 & Q42)

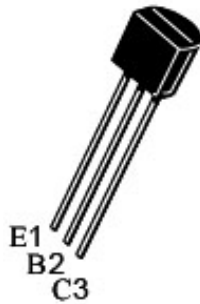

2SA970GR (Q5, Q11, Q14, Q16, Q21 & Q22)



- 1. EMITTER
- 2. COLLECTOR
- 3. BASE

MPSA42 (Q9, Q10, Q12, Q13, Q17, Q18, Q19, Q20, Q31, Q36, Q37, Q38, Q40, Q41, Q43, Q44 & Q45)

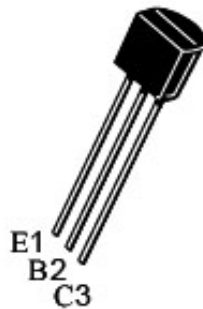

MPSA14 (Q34 & Q35)

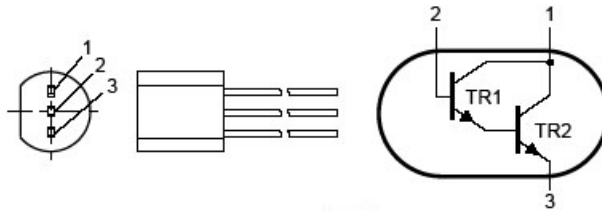

Front Panel & Mains PCB

MPSA14 (Q3 & Q4)

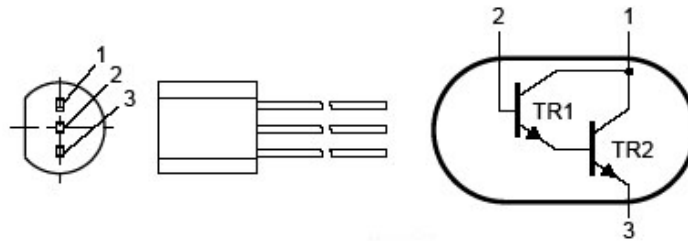

BC337 (Q1 & Q2)

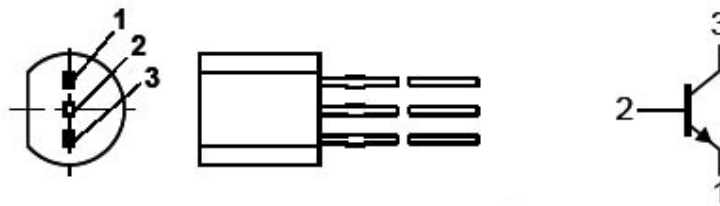

PIC16F72-I/SP

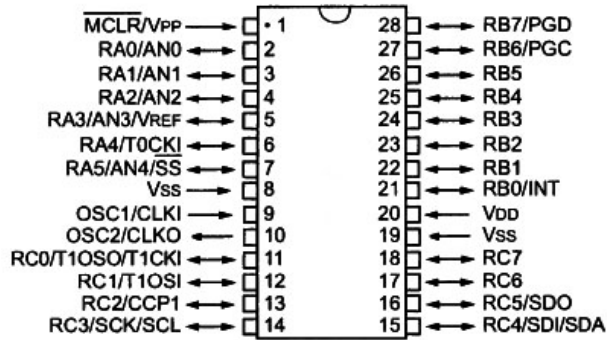

BA6218 (UI)

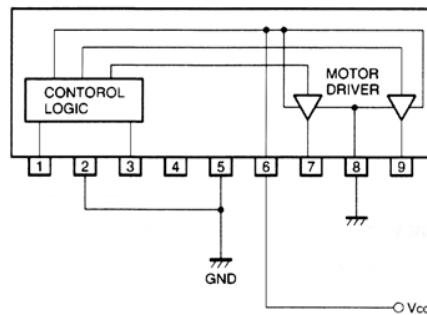

M74HC4094 (U3)

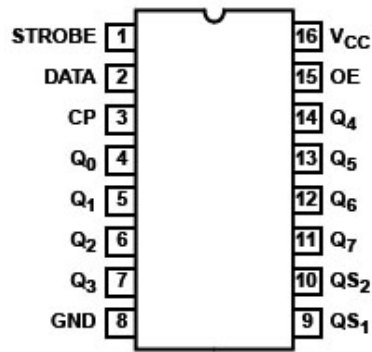

TSOP1836 (U4)

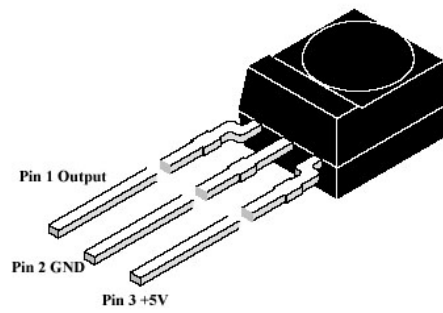

A-BUS PCB

BC337 (Q1, Q2, Q3 & Q5)

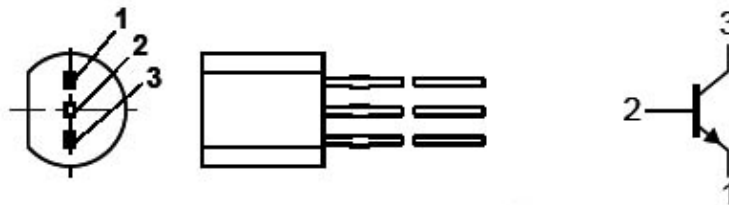

BC327 (Q4)

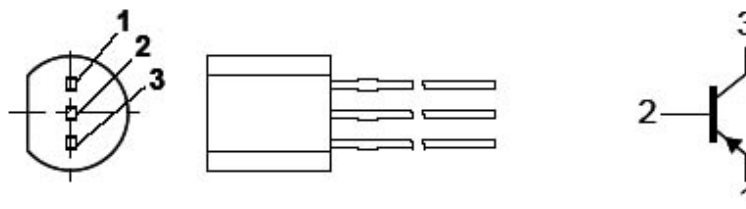

4011 (U1)

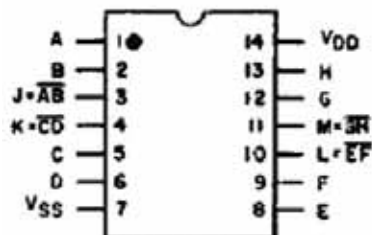

TSOP1836 (U2)

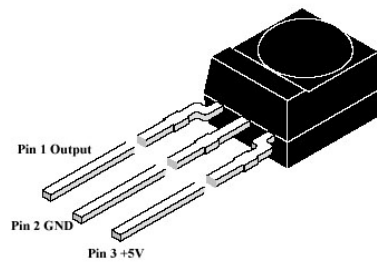

TSOP1837 (U3)

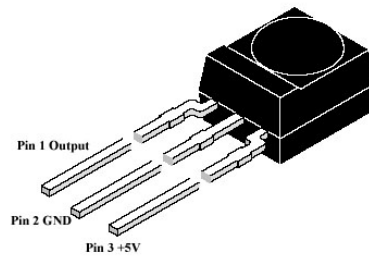

OP4N25 (U4)

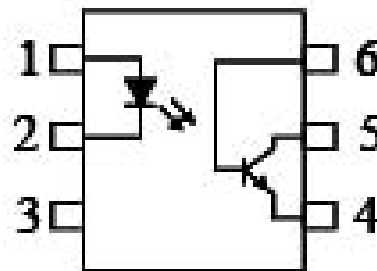

NJM5532 (U5 & U6)

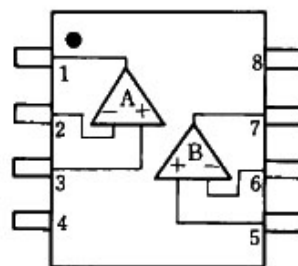

7812 (U7)

