

A & R CAMBRIDGE LIMITED

HI-FI EQUIPMENT

SERVICE DATA

A60 INTEGRATED AMPLIFIER

A60 LAYOUT AND CIRCUIT DIAGRAM

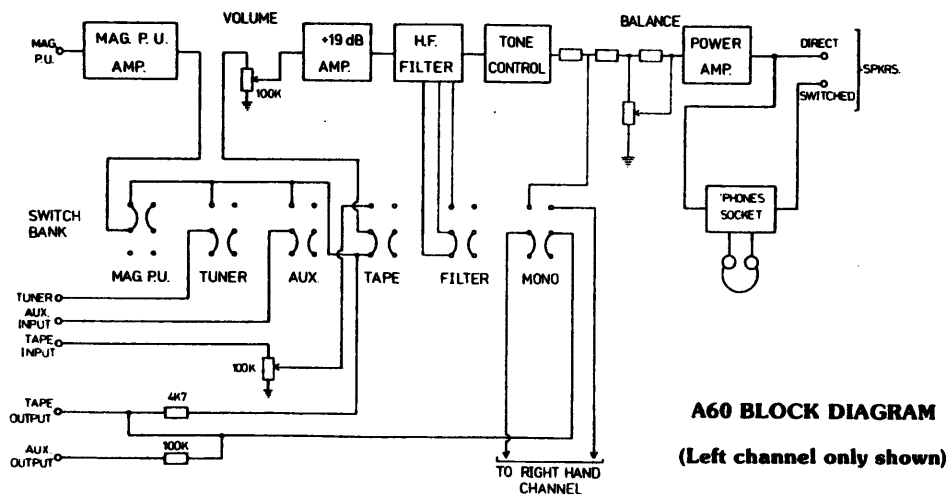
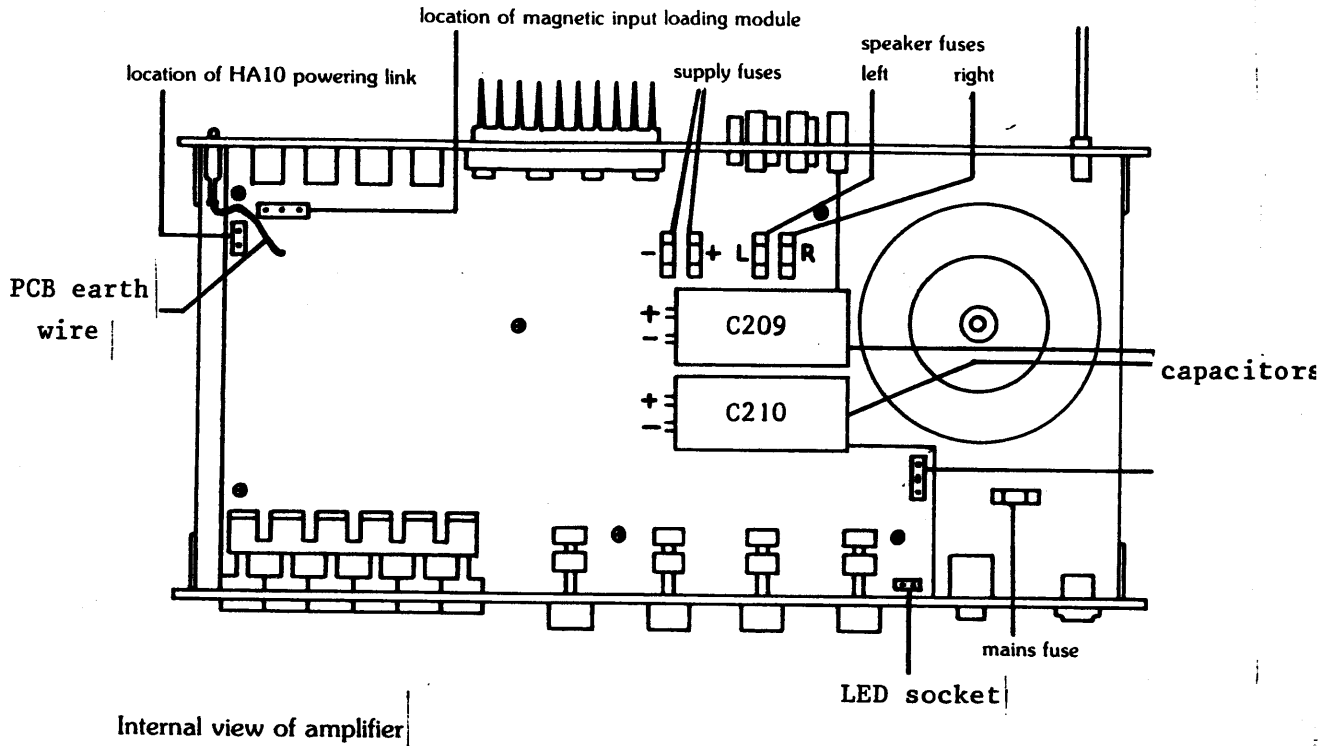

WIRING THE A60 AMPLIFIER TRANSFORMER FOR 117 V MAINS

The transformer has 8 tags on the side. The lower four, wired with white, grey and green/yellow wire, are output tags and remain the same in all models. The upper four are the mains input tags and the wiring of these differs in the 117 V and 240 V (standard) models.

The four input tags are labelled 0, 117, 0, 117. In the 240 V model, the two centre tags are linked, as shown in figure 1. The live and neutral wires from the mains switch are connected to the two outer tags.

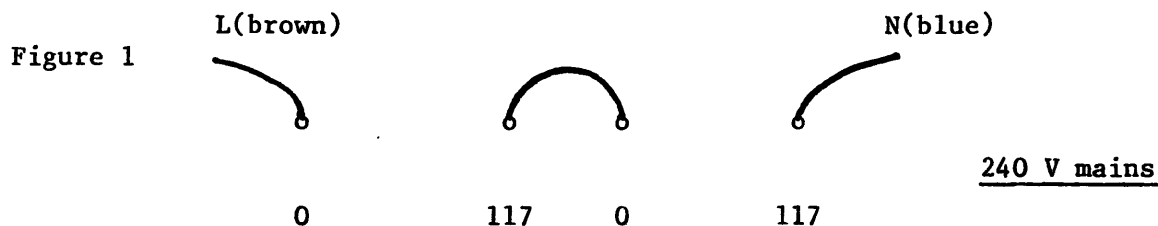

To change the wiring for 117 V mains, disconnect the two inner tags from each other and, instead, link alternate tags, as shown in figure 2.

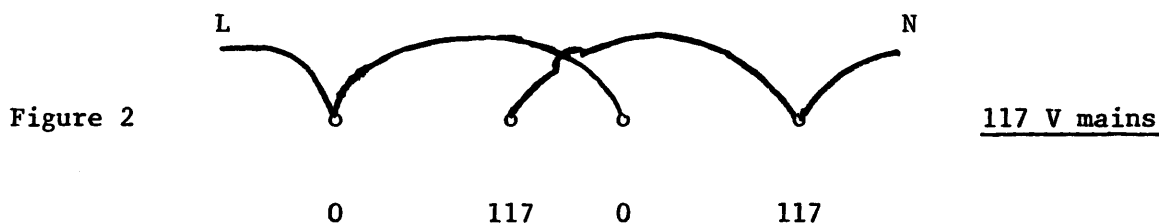

(In a small number of cases, the transformer was built slightly differently, and the tags are ordered 0, 0, 117, 117. For 240 V mains, the wiring is exactly the same as in the standard transformer. For 117 V mains, however, the wiring should be as shown in Figure 3, with the two left hand tags linked together and the two right hand tags linked together. The wires from the mains switch are connected, as before, to the two outer tags.

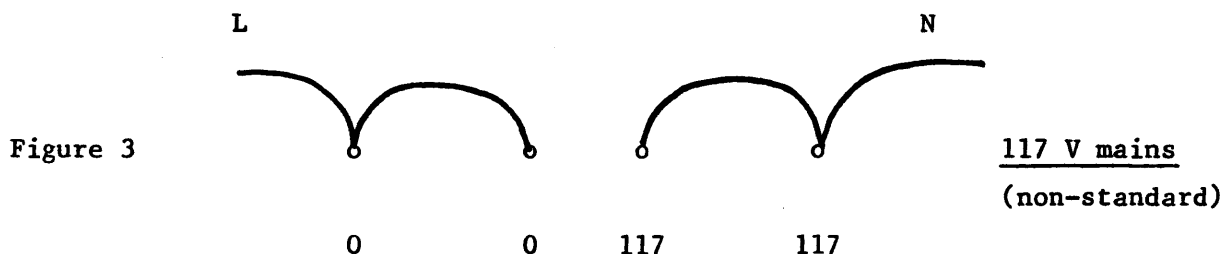

NOTE When wired for 117 V, the A60 requires a 1 Amp antisurge fuse in the internal mains fuse position in place of the 630 m Amp fuse supplied. You will find the mains fuse holder immediately in front of the transformer. Replace the plastic cover carefully after changing the fuse. This does not apply to later models which have a 1Amp fuse fitted as standard.

WARNING ENSURE THAT THE AMPLIFIER IS COMPLETELY DISCONNECTED FROM THE MAINS BEFORE ATTEMPTING TO MAKE ANY OF THESE CHANGES. IN PARTICULAR NOTE THAT, WHEN THE AMPLIFIER IS CONNECTED TO THE MAINS, THE MAINS FUSE REMAINS LIVE EVEN WHEN THE AMPLIFIER'S MAINS SWITCH IS OFF.

For your own safety, you should re-cover all four input tags with their insulating sleeves after changing the wiring.

110v

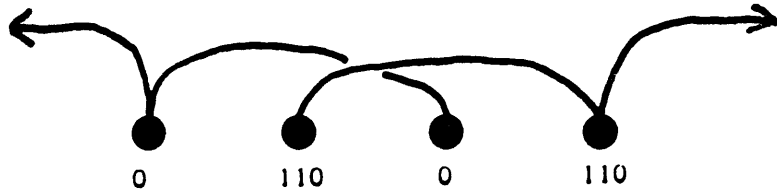

220v

EARLY MODELS

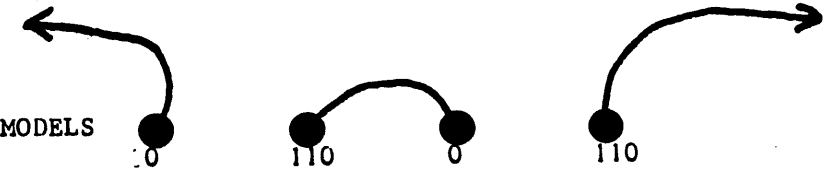

LATER MODELS

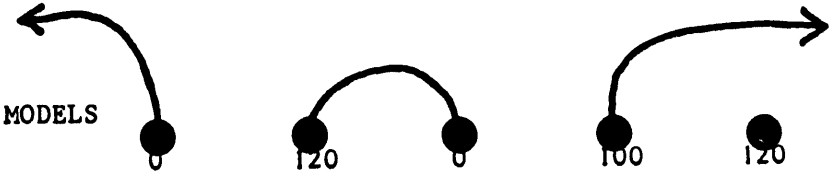

120v

EARLY MODELS

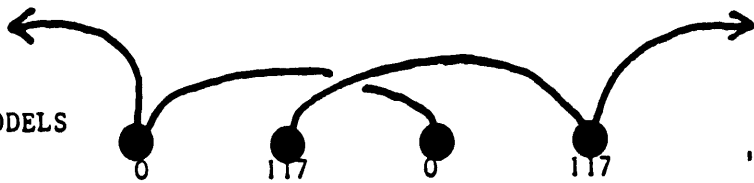

LATER MODELS

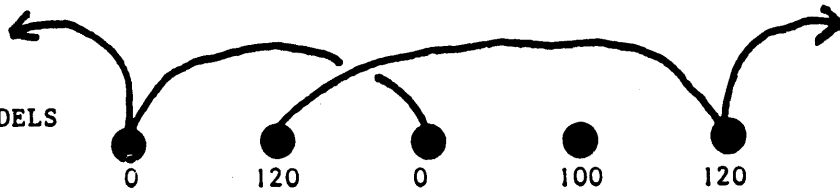

240v

EARLY MODELS



LATER MODELS

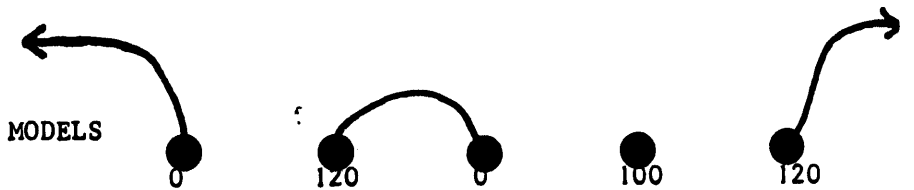

A60 AMPLIFIER

TO CHANGE THE LED INDICATOR

Remove the wooden sleeve as follows. Turn the amplifier upside down on a soft cloth or similar non-scratch surface and, using a N^o 1 'Pozidriv' screwdriver, remove the four pan-head screws near the corners of the metal baseplate. Holding the sleeve carefully in place, turn the amplifier the right way up and ease off the sleeve.

The LED is firmly fixed with cyanoacrylate ('super glue') adhesive. Care must be taken in removing it to avoid damaging the front panel.

The simplest technique is to apply a hollow headed punch to the front of the LED and hit sharply with a hammer. If a hollow headed punch is not available a piece of thin metal tubing might do instead.

Alternatively, the LED can be removed from behind thus avoiding the possibility of scratching the front panel. The connecting wires onto the LED should be broken off at the base of the red plastic and the body of the LED drilled or chiseled out. The hole can be cleaned out by hand with a small drill bit.

The new LED should be glued in carefully, applying a very small quantity of the glue, preferably of the IS12 or cyanoacrylate type to the side of the LED near its base to avoid glue spreading on to the top of the LED or on to the front panel.

When replacing the sleeve make sure that the brackets are clear of all wires and that the four screws are firmly tightened.

REMOVAL OF THE A60 P C BOARD FROM THE CASE

- 1 Remove the wooden sleeve as follows. Turn the amplifier upside down on a soft cloth or similar non-scratch surface and, using a N^o 1 'Pozidriv' screwdriver, remove the four pan-head screws near the corners of the metal baseplate. Holding the sleeve carefully in place, turn the amplifier the right way up and ease off the sleeve.
- 2 Unplug (from the right hand front of the PCB) the 3-pin connector from the transformer and the 2-pin connector from the LED.
- 3 Remove the phones socket from the front panel by unscrewing the hexagonal nut.
- 4 Disconnect the PCB earth from the tag on the left of the back panel.
- 5 Using the Allen key provided, loosen the grub screws in the control knob. Then, remove the knobs from the volume, treble, bass and balance controls.
- 6 Remove the two heatshunt screws from the back panel (one on either side of the heat sink) using a N^o 1 'Pozidriv' screwdriver. Take great care not to destroy the screw heads.
- 7 Using the same screwdriver, remove the 6 screws holding the PCB to the base plate (one at each corner, one in the middle and one between the volume and treble pots.)
- 8 Using the same screwdriver remove the 2 screws retaining the loudspeaker socket sub-panel (one each side of the aperture). The sub-panel can then be eased forward into the amplifier case, taking care not to damage the wiring, or any components. It may be easier if the top three loudspeaker terminals are screwed out first.
- 9 Carefully remove the PCB from the case. Lift upwards from the back and ease the switches and potentiometers spindles through the holes in the front panels.

PRECAUTIONS WHEN REPLACING FAULTY COMPONENTS IN THE A60 POWER AMPLIFIER

If any transistor has had to be replaced in the power amplifier, the following procedure must be used to reset the output quiescent current.

- i Remove the power supply fuses (3.15 A)
- ii Replace these fuses with blown fuses with 15 ohm wirewound (about 5 watt) resistors wired across them. This protects the amplifier if there is a further undiscovered fault.
- iii Connect an AVO or other voltmeter on its 10 volt range across the resistor in the positive supply (right hand looking from the front of the amplifier). This meter is used to measure quiescent current (I_Q) via the voltage drop in this resistor. This is why I_Q will always be expressed as a voltage.
- IV Turn both quiescent current presets (RV2, 102) fully anticlockwise (they may be stiff as they will have been sealed).
- v Make sure that the volume control is turned right down and that there are no other connections to the amplifier, then switch on while observing the meter. It should read in the region of 0.5 to 0.6 volts.
- vi If this is the case, switch the meter to a more sensitive (eg 3 volt) range.
- vii Turn up RV2 until I_Q increases by about 0.2völts..
- viii Turn up RV102 until I_Q increases by about a further 0.2 volts
- ix The amplifier should now be left to warm up for a few minutes during which time I_Q should increase to about 1.4 to 1.6 volts. It should not be allowed to go over 1.8 to 1.9 volts.
- x The amplifier can now be fully checked in this condition provided loudspeaker loads are not connected. Aural monitoring may be achieved using headphones.
- xi When you are satisfied that the amplifier is working correctly, switch off and allow about one minute for the reservoir capacitors to discharge. Then remove the 15 ohm resistors and replace with 3.15 Amp quick blow fuses. If possible reseal RV2 and 102 (we use nail varnish!)

FAULTY (OPEN CIRCUIT) RESERVOIR CAPACITOR(S) - SYMPTOMS AND DIAGNOSIS

This is the only recurrent fault we have had with the A60, and luckily it is easily diagnosed and cured, and is only prevalent in early A60's (ser.No. less than 1400).

The symptoms are:

- i A continuous low--level buzz from the loudspeakers even with the volume control turned to zero.
- ii A sharp crack at switch-on.
- iii Severe mains intermodulation at all but the lowest power levels (often described by the customer as 'distorted bass when I play it loud').

To confirm the diagnosis and to find which reservoir capacitor is the culprit use an AVO or other multimeter set to a 50-100 volt DC range. Measure the voltage across C209 (positive supply) and C210 (negative supply). They should both be 35 to 36 volts with a 240 volt mains supply. If one is open circuit it will read 20 to 25 volts.

Alternatively, an oscilloscope may be used to observe the ripple waveform on the power supplies. Under no signal conditions this should be 150 mV to 250 mV peak-to-peak. A faulty reservoir capacitor will give up to about 30 volts peak-to-peak!

Having identified the faulty component it may easily be replaced using the technique described overleaf.

QUICK REPLACEMENT OF RESERVOIR CAPACITORS

1 Remove the wooden sleeve as follows. Turn the amplifier upside down on a soft cloth or similar non-scratch surface and, using a N^o 1 'Pozidriv' screwdriver, remove the four pan-head screws near the corners of the metal baseplate. Holding the sleeve carefully in place, turn the amplifier the right way up and ease off the sleeve.

2 The reservoir capacitors are the two large cylindrical components to the immediate left of the toroidal transformer. To remove a capacitor:

- i) Unsolder the tags from the wires protruding from the board.
- ii) Cut the capacitor tie just above the clip and push the short length remaining through the clip. Leave the tie itself in place.

3 To wire in the replacement capacitor:

- i) Align the capacitor with the red labelled terminal to the rear of the amplifier ie to the wire marked+.
- ii) Solder the two wires to the corresponding capacitor tag, ie + wire to red tag, - wire to uncoloured tag.
- iii) Thread the end of the old tie through the clip in the new tie, aligning the new clip below the top of the capacitor and on the opposite side to the old clip.
- iv) Thread the end of the new tie through the clip in the old tie and tighten it by pulling the free end with pliers. Cut off the excess lengths of cable ties.

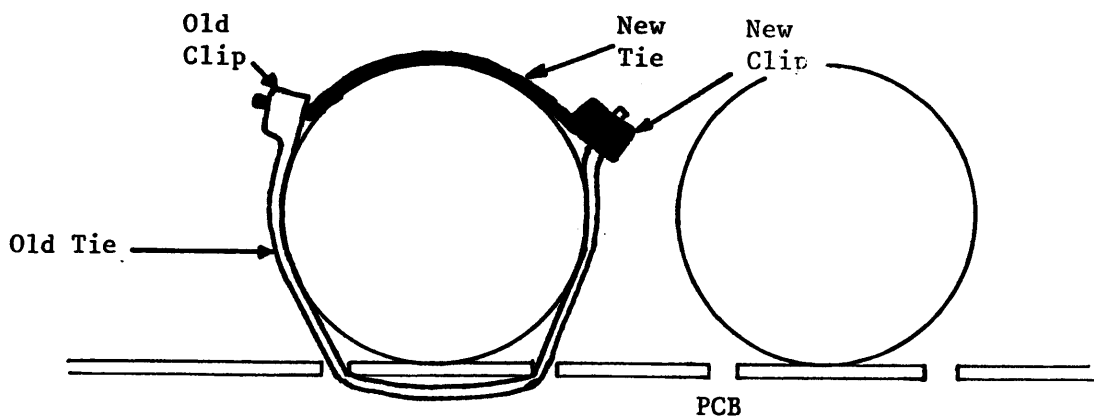

4 When replacing the sleeve make sure that the brackets are clear of all wires and that the four screws are firmly tightened.

A60 AMPLIFIER

Changing the front panel

- 1) With the amplifier switched off and unplugged from the mains, remove the wooden sleeve as follows:
Turn the amplifier upside down on a soft cloth or similar non-scratch surface. Using a no. 1 pozidriv screwdriver, remove the four pan-head screws near the corners of the metal base plate. Holding the sleeve carefully in place, turn the amplifier the right way up and ease off the sleeve.
- 2) Line up the four control knobs (volume, treble, bass and balance) in the 12 o'clock positions. Use the Allen key (provided in the spares kit) to loosen the grub screws and remove the knobs. **IT IS IMPORTANT TO KEEP THE KNOBS IN THE RIGHT ORDER SO THAT EACH KNOB IS EVENTUALLY REPLACED IN ITS ORIGINAL POSITION, OTHERWISE CALIBRATION ACCURACY MAY BE LOST.**
- 3) Unplug the LED indicator wire from the printed circuit board. Remove the four push-on terminals from the mains on/off switch. Undo the black nut from the phones socket and withdraw socket from the front panel. (taking care not to lose the spacing washer).
- 4) Turn the amplifier base up and, using a no.1 pozidriv screwdriver, remove the three screws fixing the front panel to the base plate.
- 5) Slip the old panel off towards the front and replace with the new panel. Fix into position using new countersunk screws if possible (since the old heads may have become damaged on removal). Screw in each screw loosely at first and then tighten in turn.
- 6) Turn the amplifier right side up. Plug the new LED indicator in to the printed circuit board; plug the push-on connectors on to the mains switch as indicated in the sketch below; remount the phones socket, taking care not to damage the front panel while tightening the nut.

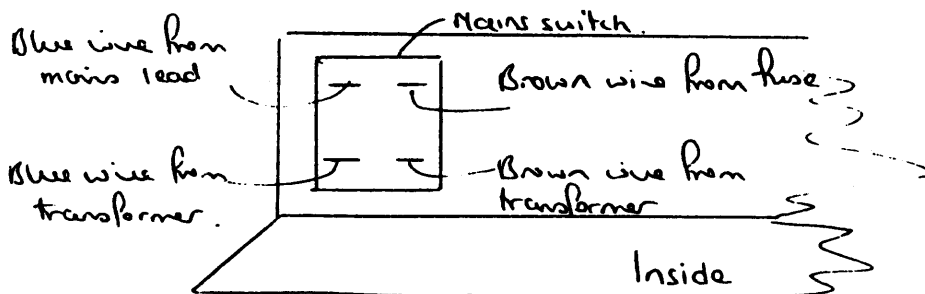

- 7) Remount the control knobs using the calibration procedure described in the A60 test sheet (refer to Service Data), section F6.
If the test equipment for recalibration is not available, then a good approximation can be achieved as follows: with the flats on the potentiometers still in the 12 o'clock position, preferably unmoved from 2) above, replace each knob on its corresponding spindle, lining up in the 12 o'clock position. As the grub-screw is gently tightened, the knob should relocate in its original position.
- 8) When replacing the sleeve make sure that the brackets are clear of all wires and that the four screws are firmly tightened.

RESETTING THE IQ ON THE A60 AMPLIFIER

1. Remove power supply fuses(3.15A).
2. Replace fuse with 15ohm wirewound resistors(about 5 watt).
3. Connect a DVM across the resistor in the positive fuseholders place.
4. Turn both IQ presets (RV2, 102) fully anticlockwise.
5. Switch on and observe meter reading. It should be in the region of 0.5 to 0.6V(500 to 600mV).
6. Turn up RV2 until the reading increases by about 0.2V.
7. Now turn up RV102 until the reading increases by a further 0.2V.The meter reading should now be about 1.0V.
8. Leave the amplifier to warm up for a few minutes during which time the reading will rise to approximately 1.4 to 1.6V. IT SHOULD NOT BE ALLOWED TO RISE ABOVE 2.0V.
9. The amplifier can now be fully checked providing no loads are connected. Aural monitoring can be done using headphones.
10. If all is now okay switch off and replace the 15ohm resistors with 3.15A fast blow fuses.

N.B.

When repairing the A60 power amplifier we advise replacement of the following components:

Q13,Q14,Q15,Q16,Q17,Q18,Q19,Q20 and Q21 (Or the right hand equivalents)

These parts are available as a kit which contains all of the above transistors and R63,64, the 0.22 Ohm resistors.

A60 UPGRADE

The A60 upgrade is suitable for all A60's with serial numbers between 13250 and 25502 inclusive.

PART No.	QTY	DESCRIPTION	COMPONENT REFERENCE
1H133	8	330R M/F	R1,17,18,24,101,117,118,124
1H227	10	2K7 M/F	R38,39,40,43,75,138,139,140,143,175
1H247	4	4K7 M/F	R15,26,115,126
1H268	4	6K8 M/F	R32,33,132,133
1H310	14	10K M/F	R22,23,27,28,29,34,45 122,123,127,128,129,134,145
2D110	2	100p POLY	C1,101
2D147N	4	470p POLY	C36,38,136,138,C8,108,23,122
2H410	2	100n POLYCARB	C11,111
2N610	2	10u / 50V	C205,206
2D222	2	2n2 POLY	C17,117
6A320	3	Click stop pot	RV202,203,204
E10202A	1	New overlay	Front panel overlay

THE ABOVE COMPONENT CHANGES APPLY TO A60'S WITH SERIAL NUMBERS >19999
IF THE SERIAL NUMBER IS LESS THAN THIS THE OVERLAY AND CLICK STOP POTS
NOT BE FITTED BUT THE OTHER CHANGES CAN STILL BE DONE.

6382

A60 SERVICE MANUAL (SERIAL NUMBERS 0001 -)

DISC INPUT (SERIAL NUMBERS LESS THAN 13250)

On the early amplifiers the disc stage was a discrete design. Transistors Q1 and Q2 form a two stage amplifier with an active load, Q22 and Q23. Feedback is frequency dependant to give the correct RIAA equalisation and is determined by R8,11 and C4,6. Q3 is an emitter follower to buffer the output of the disc stage. This disc amplifier provides approximately 33 dB of gain at 1 KHz.

Moving coil use requires an additional external preamplifier, the HA10, which on serial numbers greater than 3981, can be powered from the A60 with the insertion of a plug in link.

DISC INPUT (SERIAL NUMBERS GREATER THAN 13250)

The disc input will accept moving magnet cartridges as standard but for moving coil cartridges an optional preamplifier, MC60, can be plugged in to provide the additional amplification.

The moving magnet and RIAA equalisation is based around an NE5534 low noise op-amp. The frequency dependant feedback network relies on R5 and C3 at low frequencies and R6 and C4 (and C5 if fitted) at high frequencies. C2 provides low frequency roll off and R3 helps determine the gain. C6 maintains high frequency stabilisation of the i.c.

INPUT SELECTION

This is provided by the 6 way switchbank which also includes the mono and filter switches.

The selected input is automatically passed to the tape outputs and tape monitoring with 3 head machines is accessible by pushing the tape button in whilst recording.

LINE PREAMPLIFIER

This is a 2 stage amplifier providing 19 dB of gain. The gain is set by resistors R18 and R20. Capacitors C3 and C38 form a switchable 12 dB / octave high frequency filter with a turn over frequency at 7.5 KHz. The input to the tone control is buffered by the emitter follower Q6.

D.C. bias is provided by R202 and R203.

TONE CONTROLS

The tone control amplifier stage is based around Q7 and Q8, with a variable frequency sensitive feedback network, adjustable by the tone control pots. The output of this circuit is then buffered by Q8 before passing to the balance control and ultimately the power amplifier.

The range of the controls is determined by the end stop resistors R27, 28 for bass and R32, 33 for treble and give approximately 12 dB cut and boost at 50 Hz and 15KHz respectively. On the A60 + version the cut and boost is only 8 dB.

POWER AMPLIFIER

The input to power amplifier is fed to one input of the differential pair formed by Q9 and Q10. Q11 and Q12 form a constant current source for the differential pair.

The output from the collector of Q9 is fed to the class A stage, Q13 which is fed by the current source provided by Q14 and Q15. The output of this stage is fed to driver transistors Q18 and Q19 which then drive the quasi complementary output transistors, Q20 and Q21.

Emitter resistors R63 and R64 limit the possibility of thermal runaway with the help of Q14, which is mounted in close proximity to the heatshunt, to provide thermal feedback for the class A current source.

Short term protection of the amplifier is provided by the protection circuitry formed by R53,54,55,56,57,58,59,60; C28,29; D1,2; Q16,17

This monitors the current flow in the output stage and if it increases to much the circuit limits the base drive to the drivers. Long term protection is provided by the speaker fuse FS1 and should only be replaced with 1.6 A fast blow types to maintain protection.

Over current protection of the supply rails is obtained by a fuse (3.15 A fast blow) in both the positive and negative 36 V rails.

The quiescent current of the amplifier can be set by monitoring the current flowing through the positive fuse.(SEE SEPARATE SHEET).

POWER SUPPLY (SERIAL NUMBERS LESS THAN 13250)

The unregulated power supply consists of the transformer, a bridge rectifier, (D204,205,207,208), and smoothing capacitors C209 and C210. This provides smooth unregulated + / - 36 V rails.

The 15 V supplies are formed by simple emitter followers with a 15 V base reference provided by zeners D201 and D202. Current limiting is done by resistors R205 and R208.

On A60 serial numbers > 3981 there is an additional positive 15 volt supply which can used to power the optional external MC preamp. This also uses D201 as the base reference for the emitter follower Q203 and R212 provides current limiting.

L.E.D D203 is used to indicate power on and R210 is the current limiting resistor.

C211 across the secondary of the transformer limits high frequency interference from the mains supply.

POWER SUPPLY (SERIAL NUMBERS GREATER THAN 13250)

The unregulated power supply consists of the transformer, a bridge rectifier, (D204,205,207,208), and smoothing capacitors C209 and C210. This provides smooth unregulated + / - 36 V rails.

The 36 volt rails are then fed to positive and negative variable voltage i.c. regulators, IC 201 and 202. The potential dividers R204, 206 and R207, 209 then provide the necessary feedback for the regulator to produce 15 volt regulated supplies.

The output voltage is determined by the equation $Out = 1.25 ((r2 / r1) + 1)$ where $r2 = R206$ or $R209$ and $r1 = R204$ or $R207$.

D201, 202 provide protection against reversed polarity of the regulators on switch off. C207 and C208 suppress high frequency noise. C213, R205 and C214, R208 form RC networks which help drop the input voltage to a safe level for the regulator and also prevents the regulators whistling when the amplifier is switched off. C213 and C214 maintain the stability of the voltage regulators by providing a low input impedance.

L.E.D D203 is used to indicate power on and R210 is the current limiting resistor.

C211 across the secondary of the transformer limits high frequency interference from the mains supply.

(PN 16.06.88)

- Q9 BC547
- Q10 BC547
- Q11 BC547
- Q12 BC547
- Q13 BFR79, FST 240
- Q14 BC547
- Q15 BFR39, FST 239
- Q16 BC547
- Q17 BC557
- Q18 BFR39, FST 239
- Q19 BFR79, FST 240
- Q20 TIP3055
- Q21 TIP3055

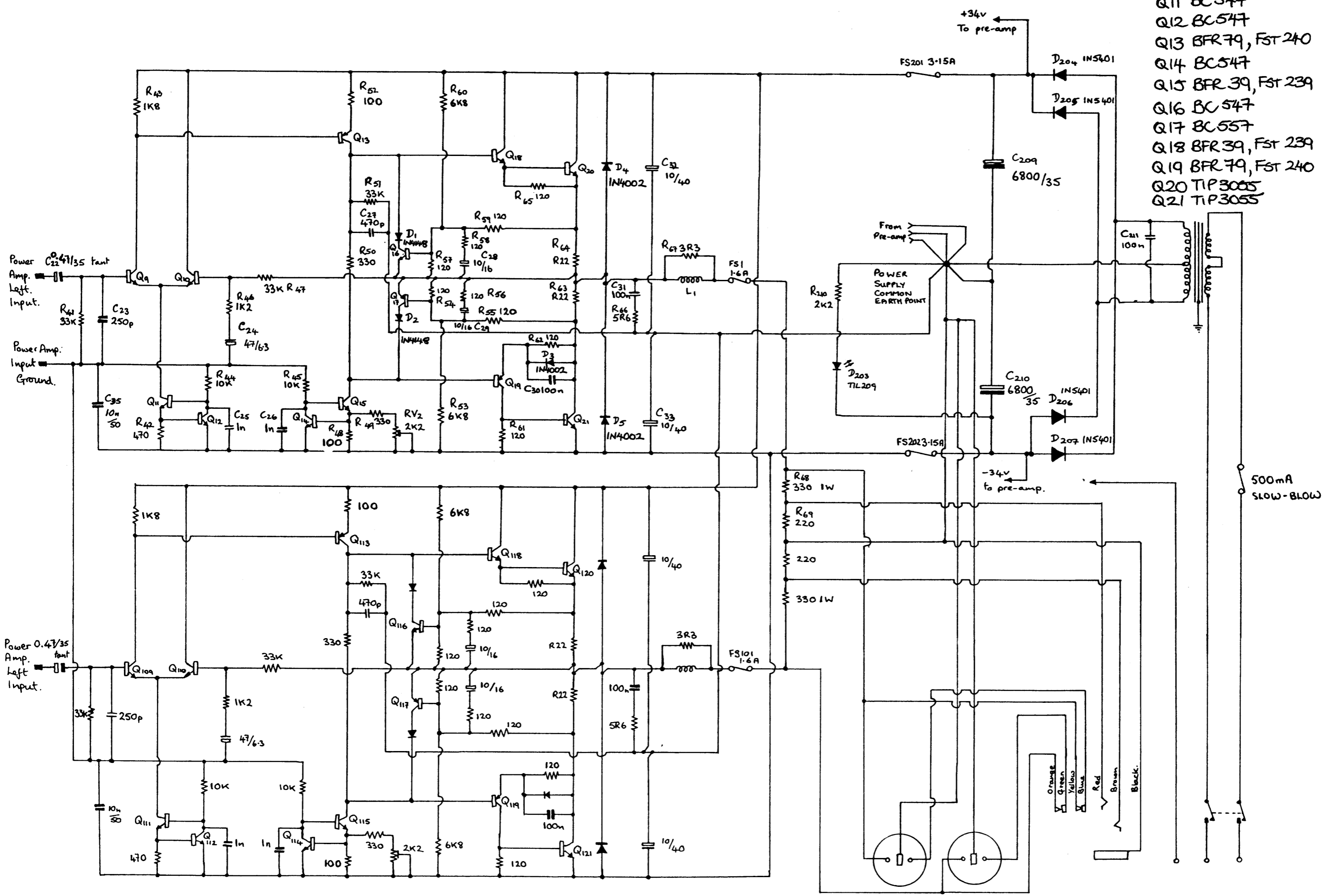

S.No 0001 - 3980

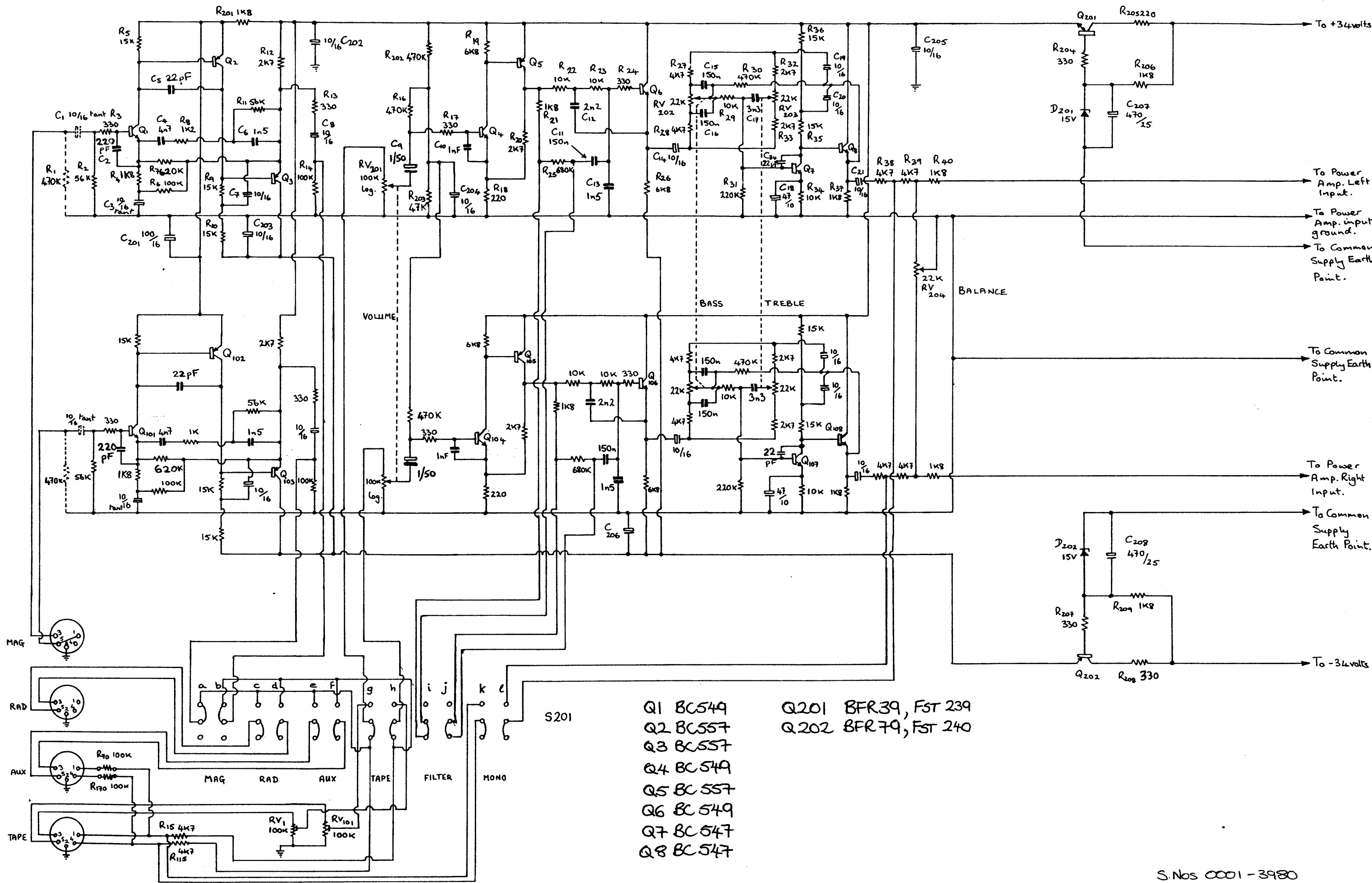

- S201
- Q1 BC549
 - Q2 BC557
 - Q3 BC557
 - Q4 BC549
 - Q5 BC557
 - Q6 BC549
 - Q7 BC547
 - Q8 BC547
- Q201 BFR39, FST 239
 Q202 BFR79, FST 240

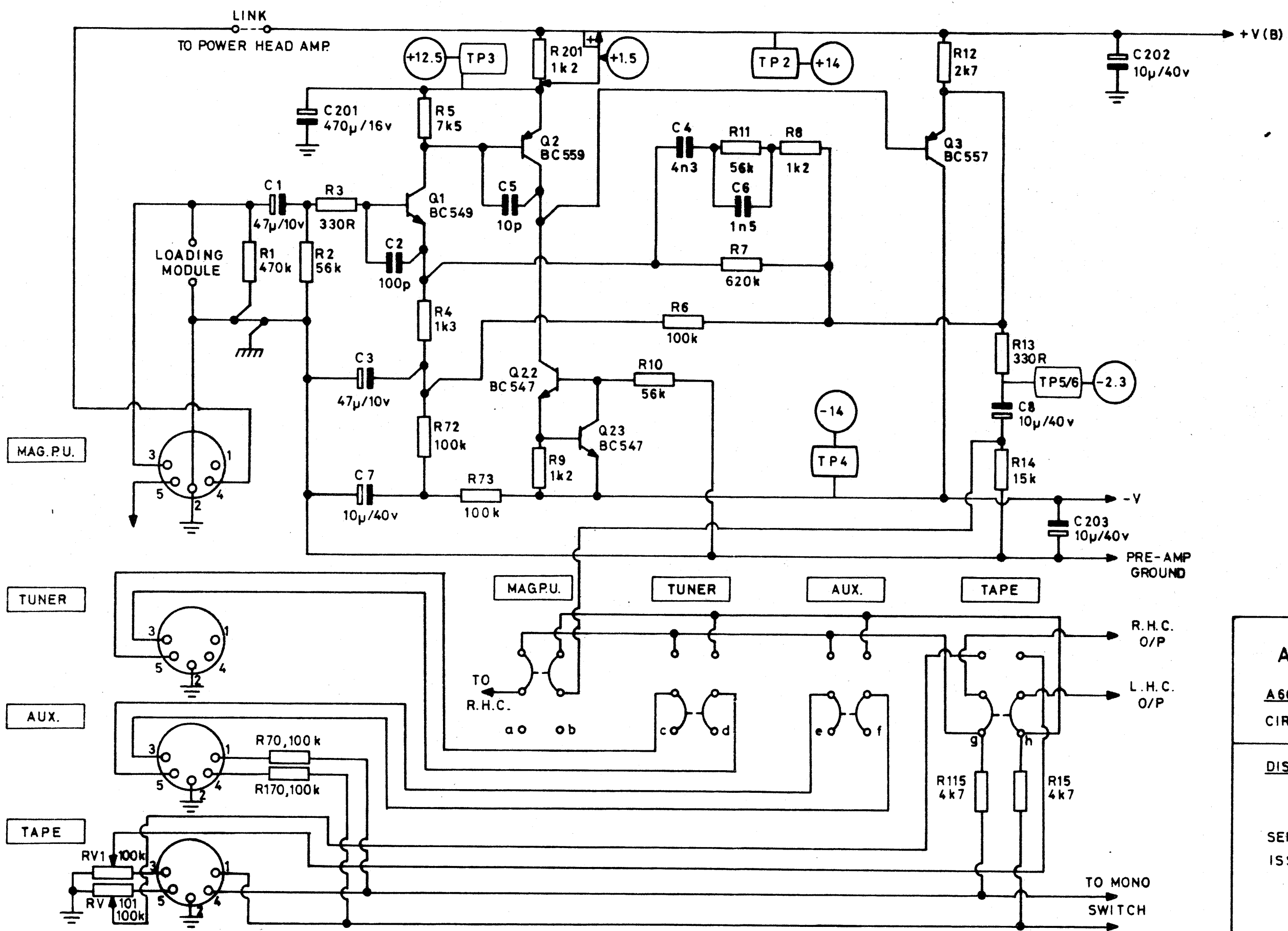

A & R CAMBRIDGE

A60 INTEGRATED AMPLIFIER

CIRCUIT DIAGRAM SHEET 1

DISC INPUT AND SELECTOR SWITCH

SERIAL NUMBERS 3981-13249
ISSUE 5 MARCH 1982

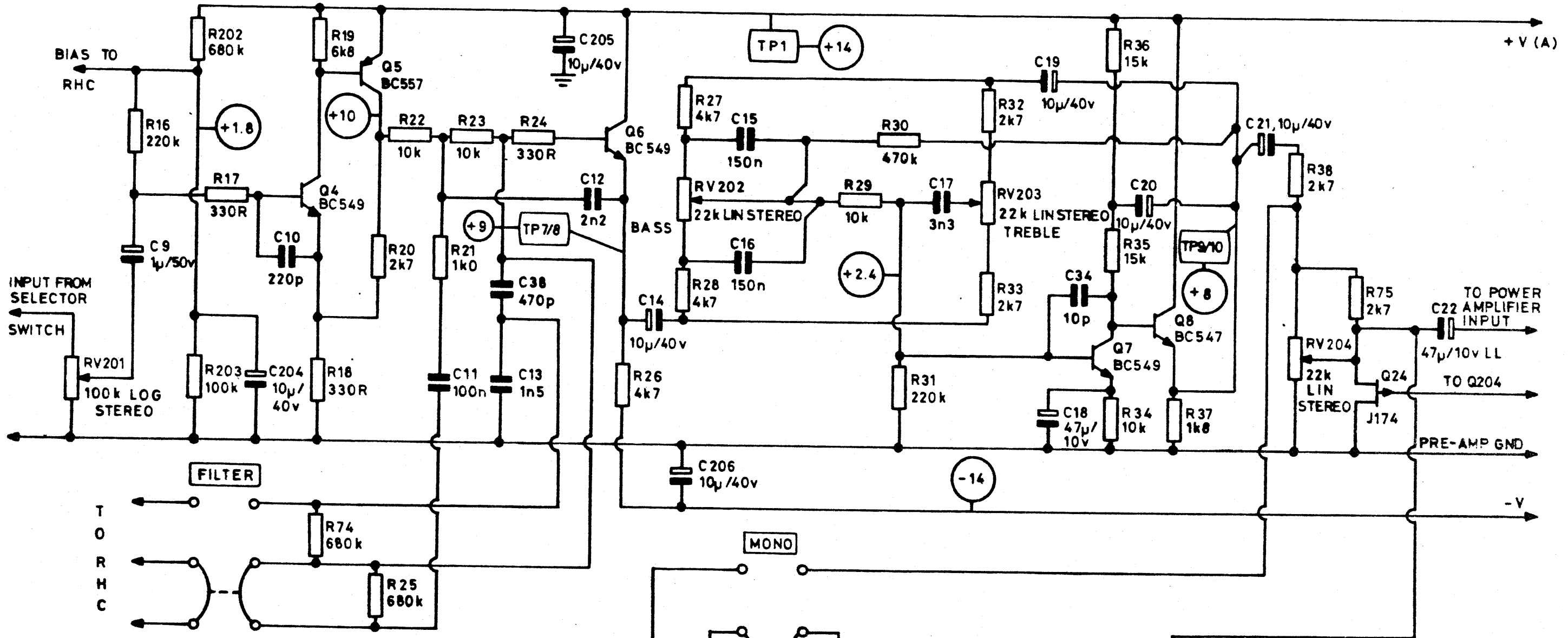

A & R CAMBRIDGE
A60 INTEGRATED AMPLIFIER
CIRCUIT DIAGRAM SHEET 2
PREAMPLIFIER AND TONE CONTROL
 SERIAL NUMBERS 3981 - 13249
 ISSUE 5 MARCH 1982

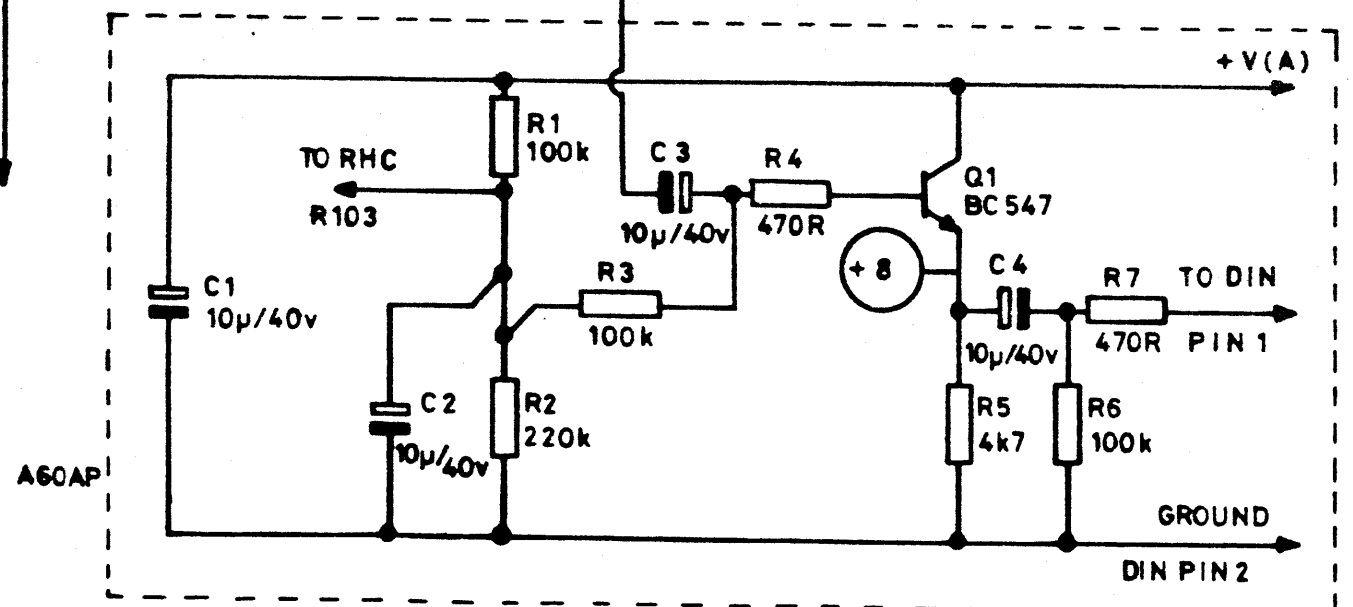
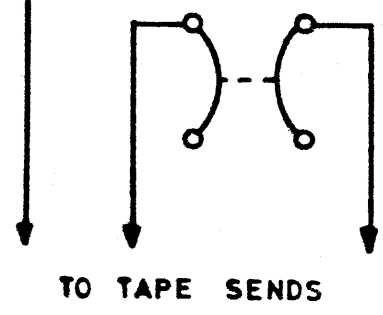

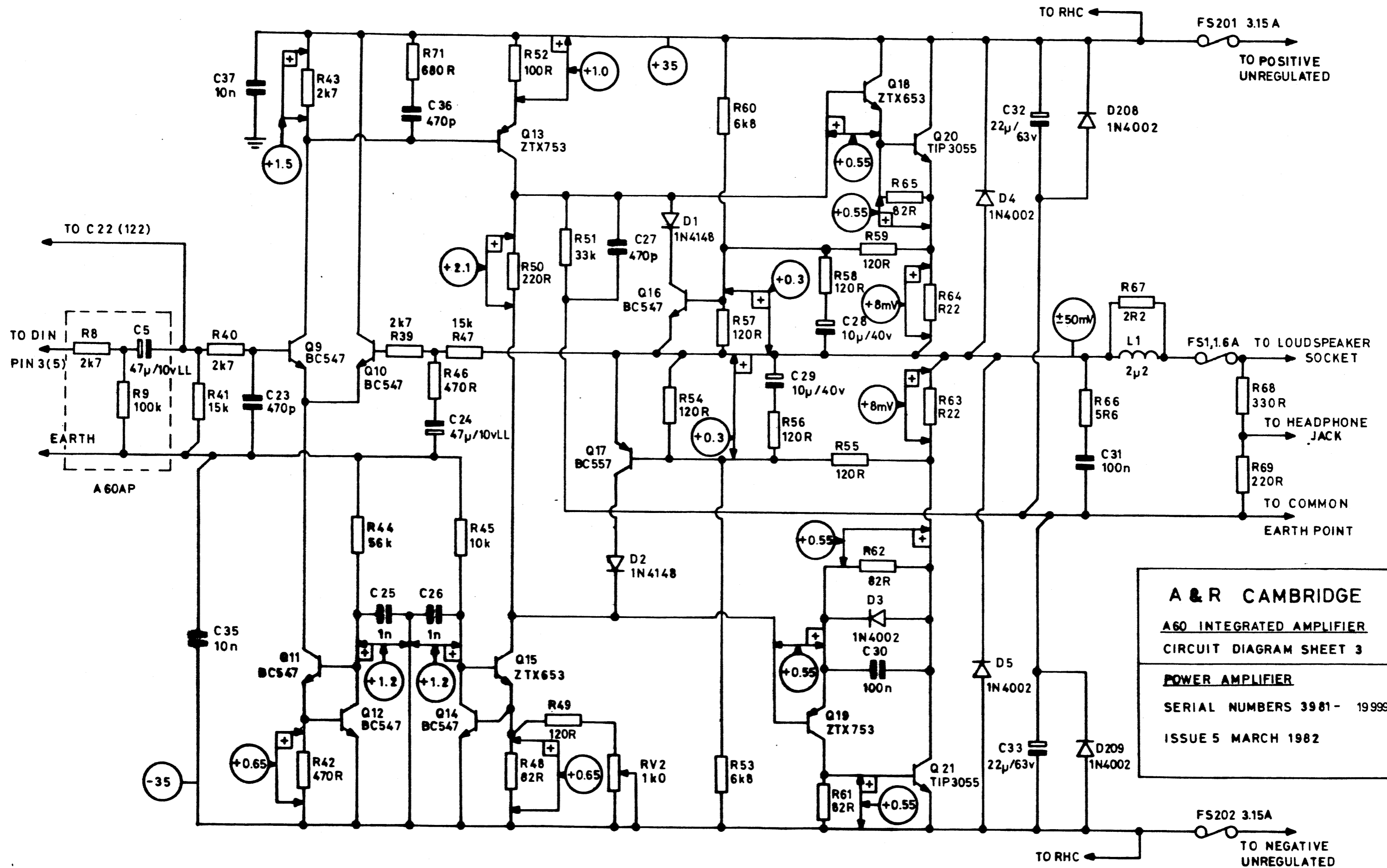

A & R CAMBRIDGE

**A60 INTEGRATED AMPLIFIER
CIRCUIT DIAGRAM SHEET 3**

POWER AMPLIFIER

SERIAL NUMBERS 3981- 19999

ISSUE 5 MARCH 1982

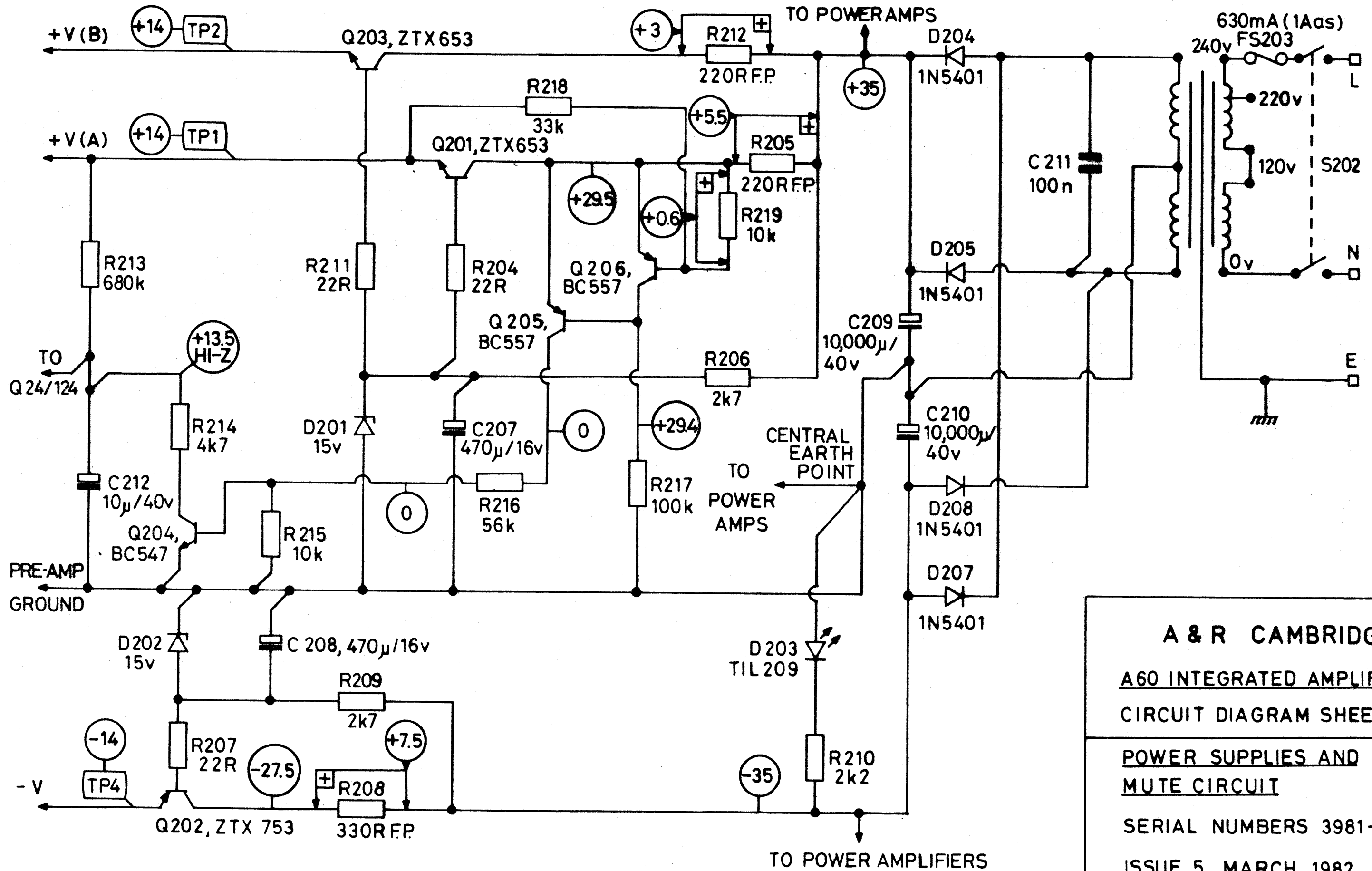

A & R CAMBRIDGE
A60 INTEGRATED AMPLIFIER
CIRCUIT DIAGRAM SHEET 4
POWER SUPPLIES AND
MUTE CIRCUIT
 SERIAL NUMBERS 3981-13249
 ISSUE 5 MARCH 1982

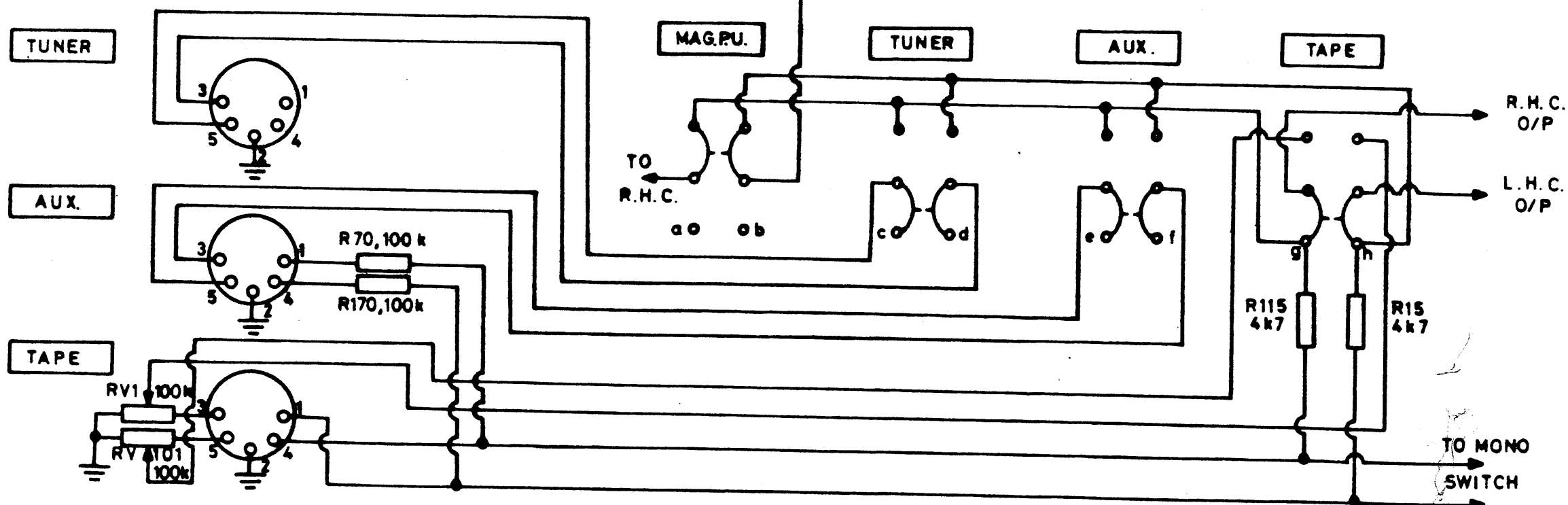
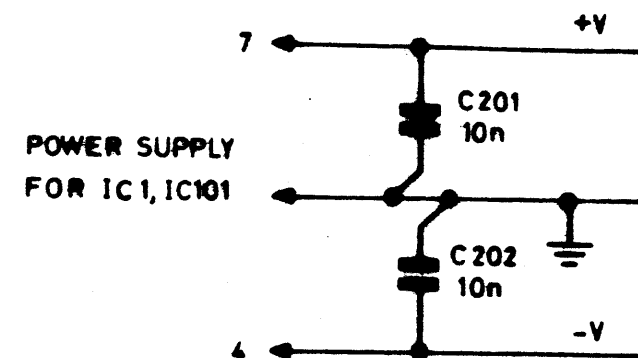
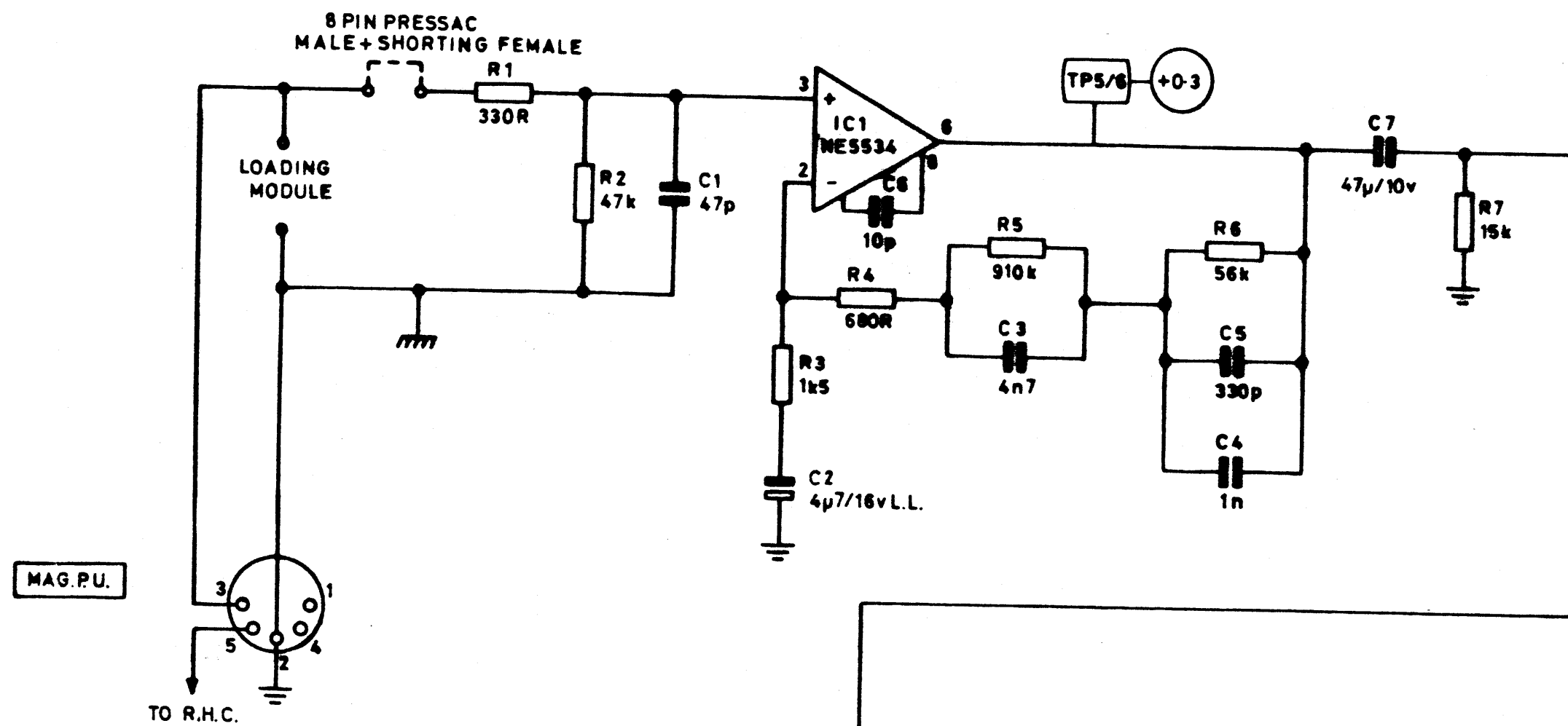

A & R CAMBRIDGE

A60 INTEGRATED AMPLIFIER

CIRCUIT DIAGRAM SHEET 1

DISC INPUT AND SELECTOR
SWITCH

SERIAL NUMBERS 13250 - 19999

ISSUE 6 JULY 1982

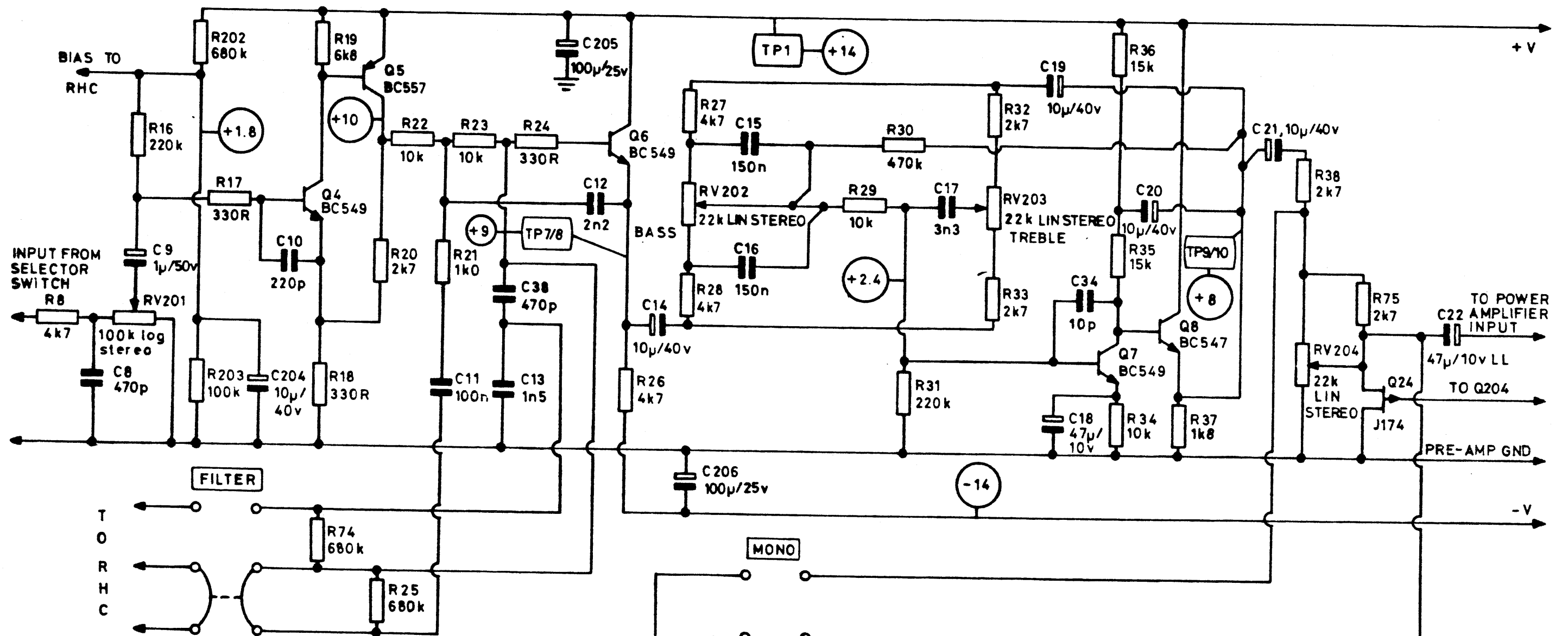

A & R CAMBRIDGE

A60 INTEGRATED AMPLIFIER

CIRCUIT DIAGRAM SHEET 2

PREAMPLIFIER AND TONE CONTROL

SERIAL NUMBERS 13250 - 19999

ISSUE 6 JULY 1982

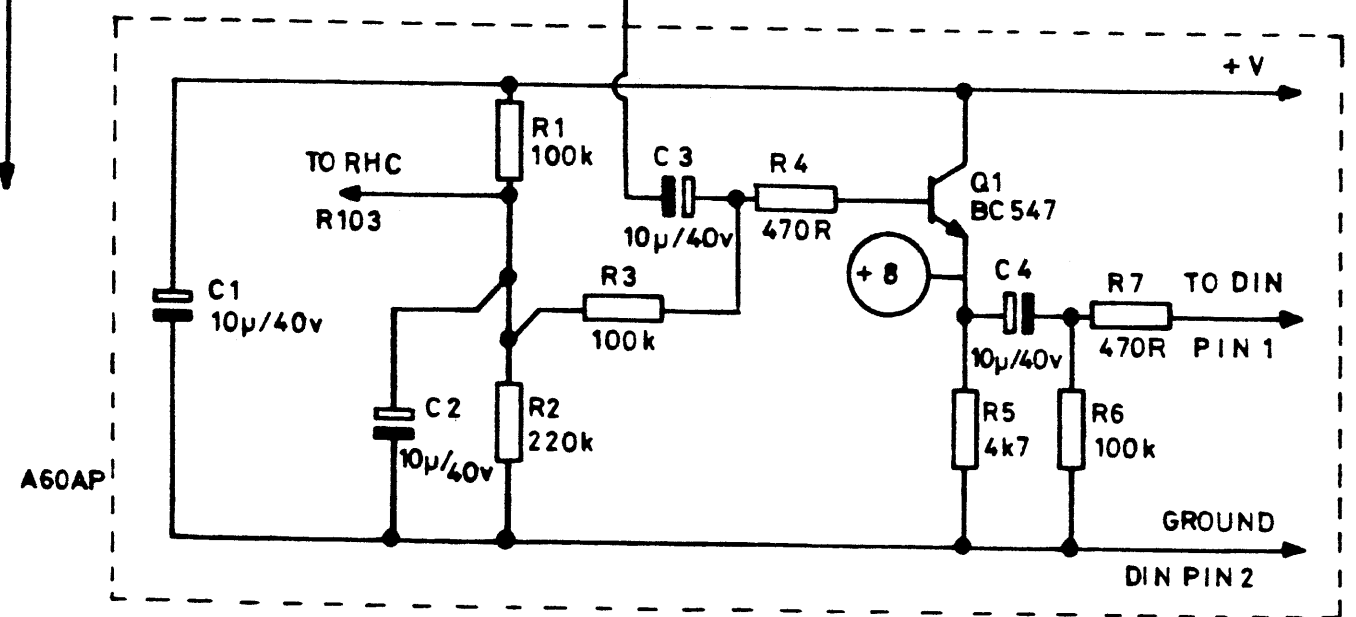

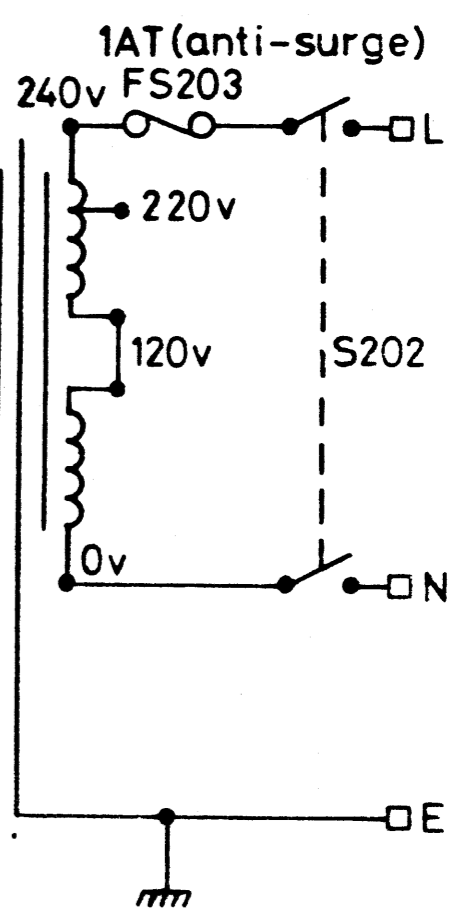
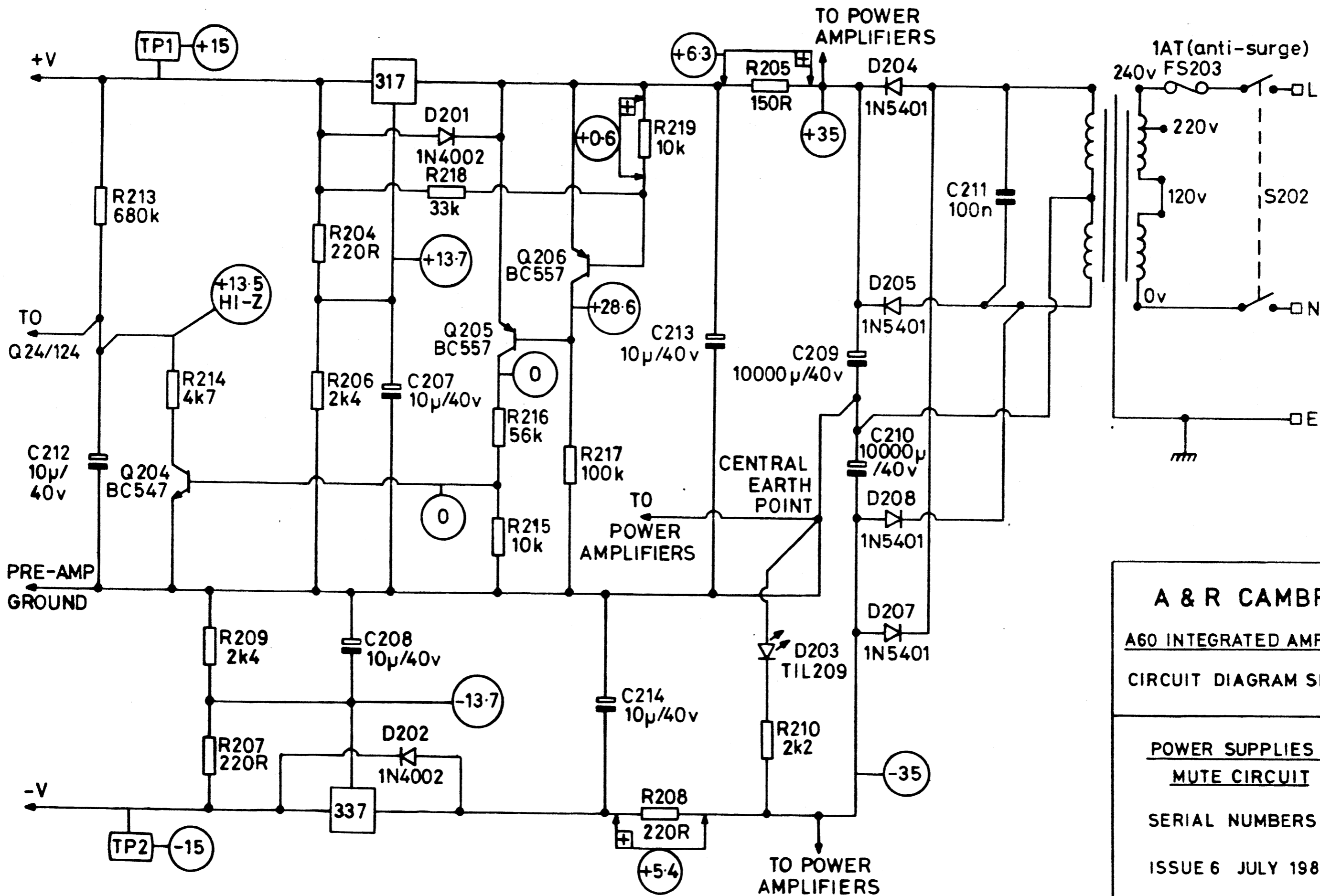

A & R CAMBRIDGE
A60 INTEGRATED AMPLIFIER
CIRCUIT DIAGRAM SHEET 4

POWER SUPPLIES AND
MUTE CIRCUIT
 SERIAL NUMBERS 13250 -
 19 999
 ISSUE 6 JULY 1982

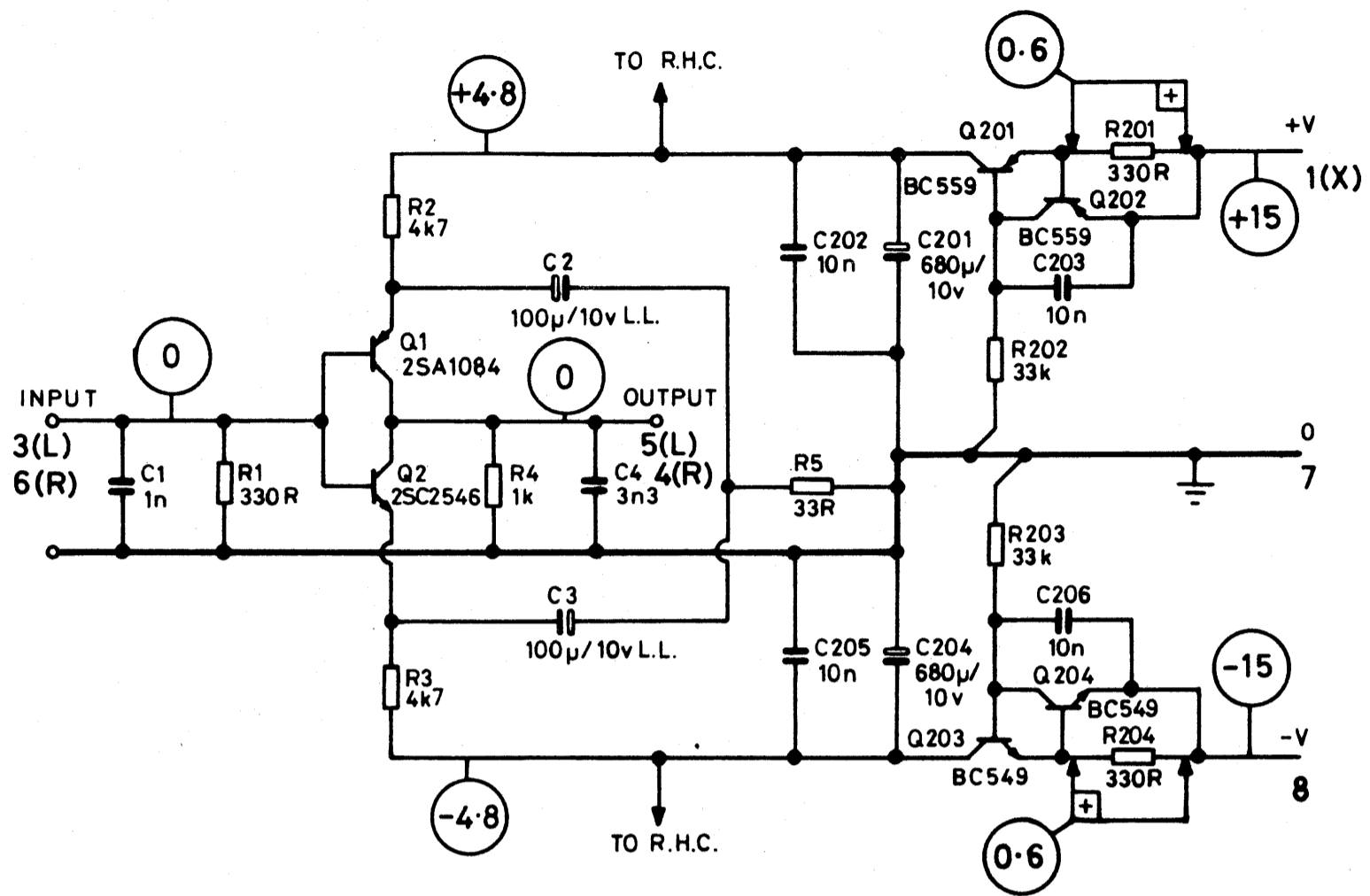

C 203, 206 CHANGED TO 1nF

A & R CAMBRIDGE LTD

A60 INTEGRATED AMPLIFIER

CIRCUIT DIAGRAM SHEET 5

MOVING COIL CARTRIDGE
PRE AMPLIFIER MODULE MC60

FOR USE WITH A60 SERIAL
NUMBERS 13250 -

ISSUE 1 18 OCTOBER 1982

AND DELTA 90sn001-

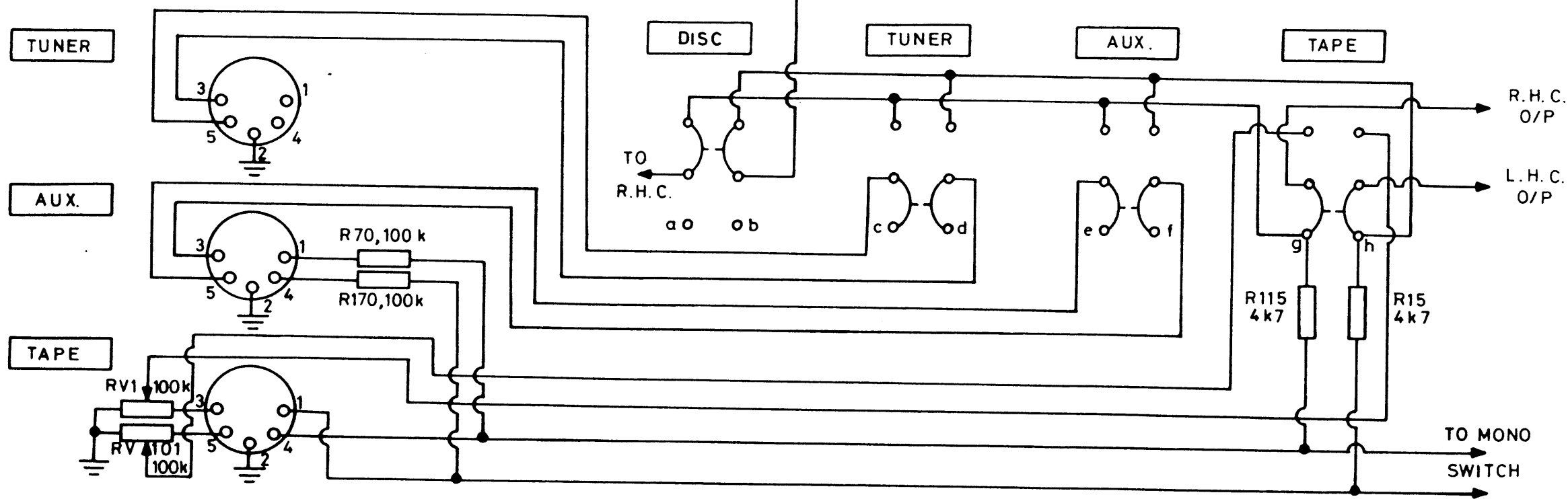
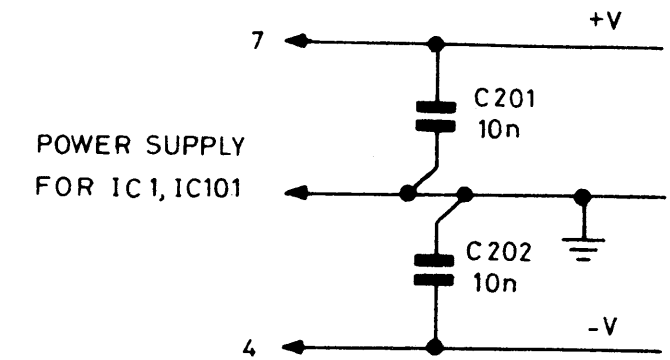
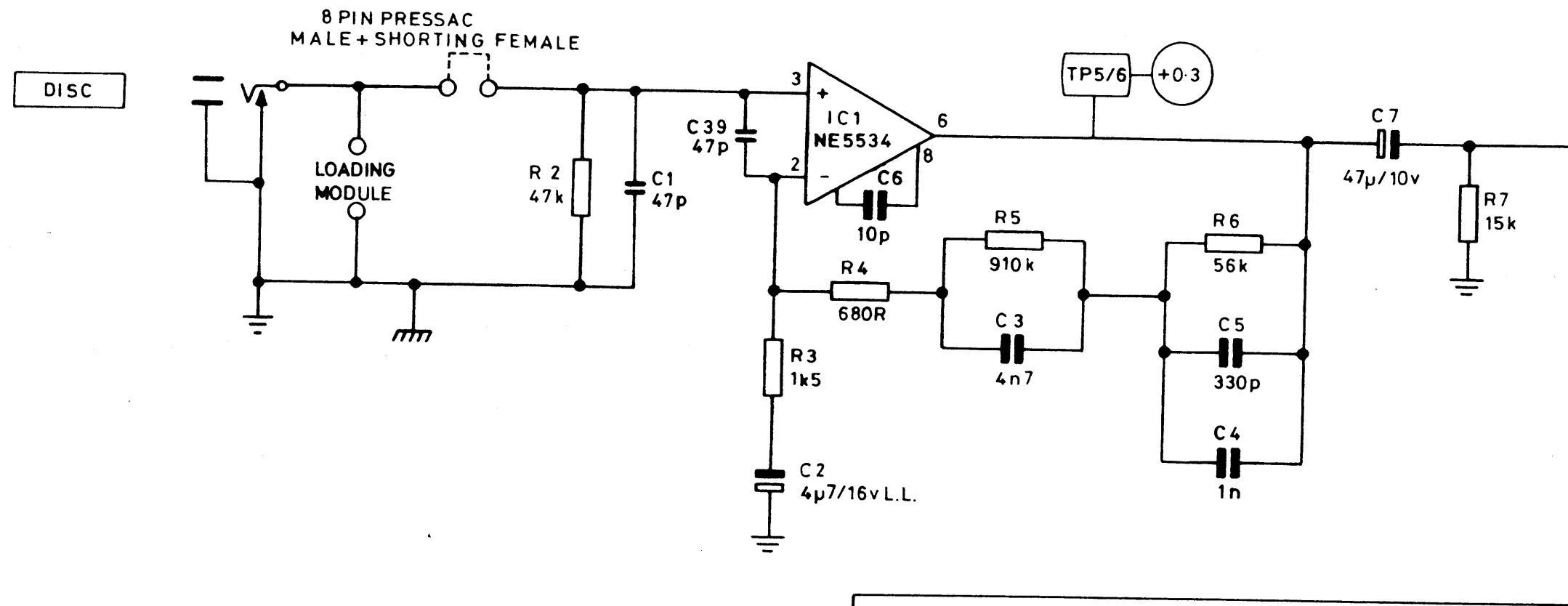

A & R CAMBRIDGE
A60 INTEGRATED AMPLIFIER
CIRCUIT DIAGRAM SHEET 1

DISC INPUT AND SELECTOR SWITCH

SERIAL NUMBERS 20000 - 25501
 ISSUE 7 AUGUST 1983

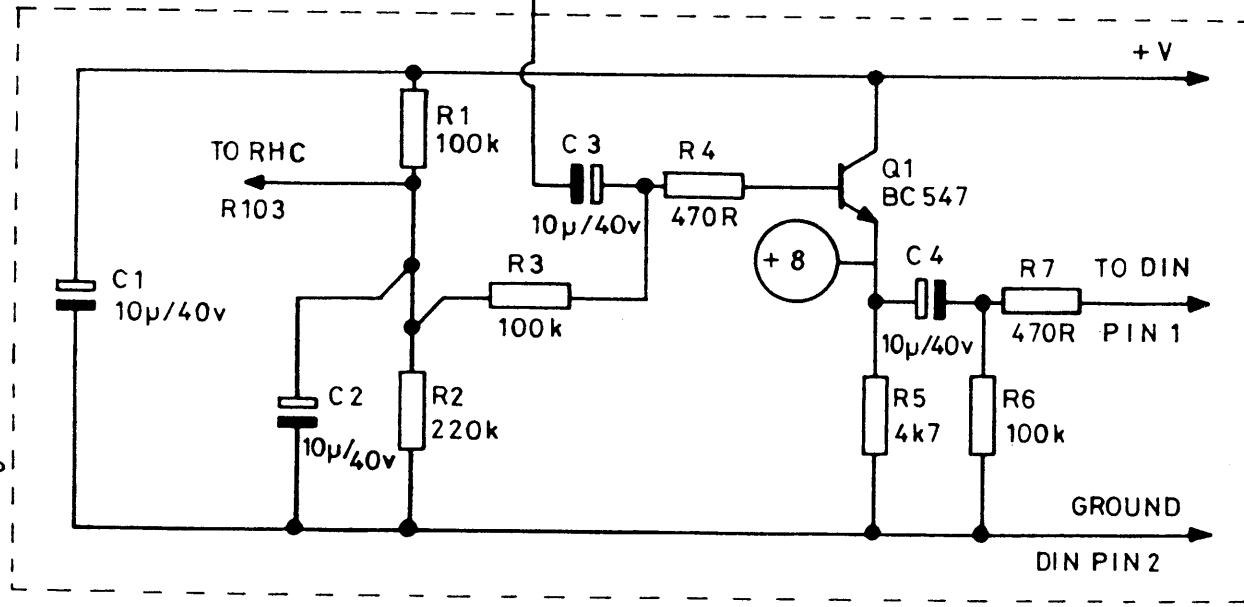
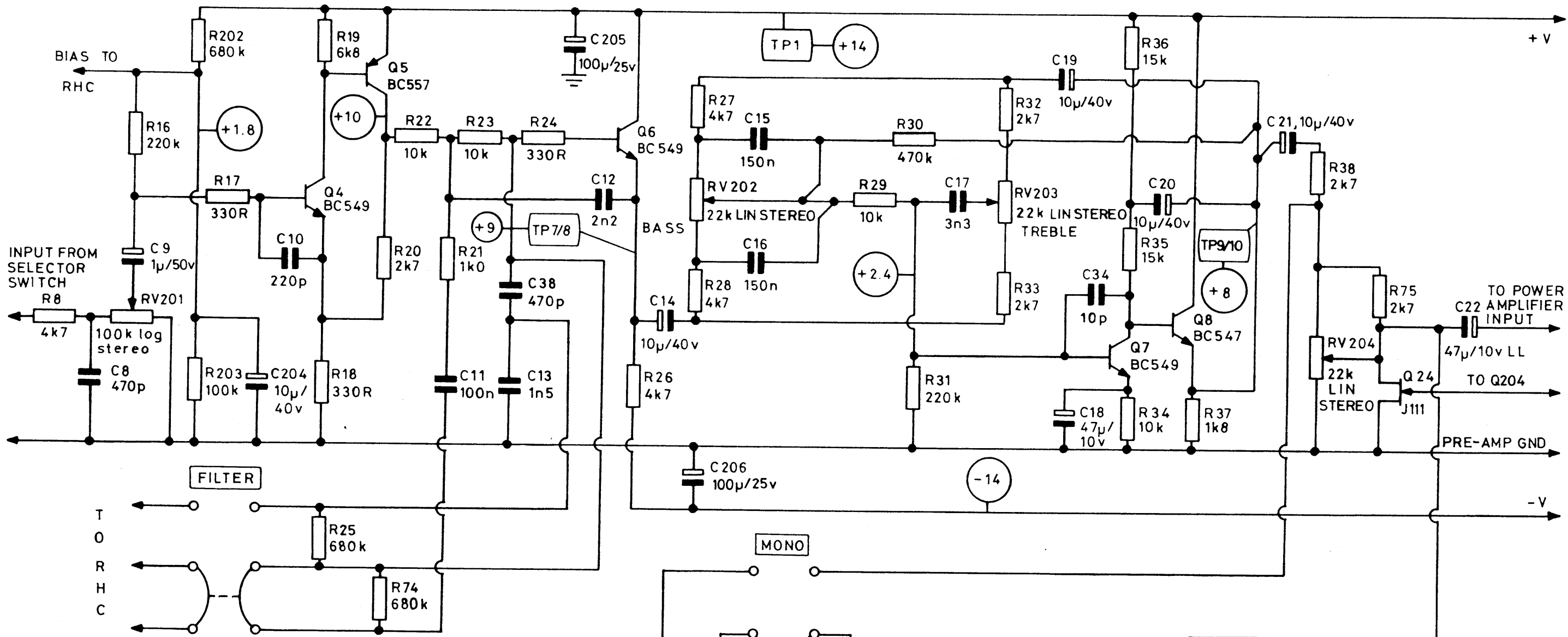

A & R CAMBRIDGE

A60 INTEGRATED AMPLIFIER

CIRCUIT DIAGRAM SHEET 2

PREAMPLIFIER AND TONE CONTROL

SERIAL NUMBERS 20000 - 25501

ISSUE 7 AUGUST 1983

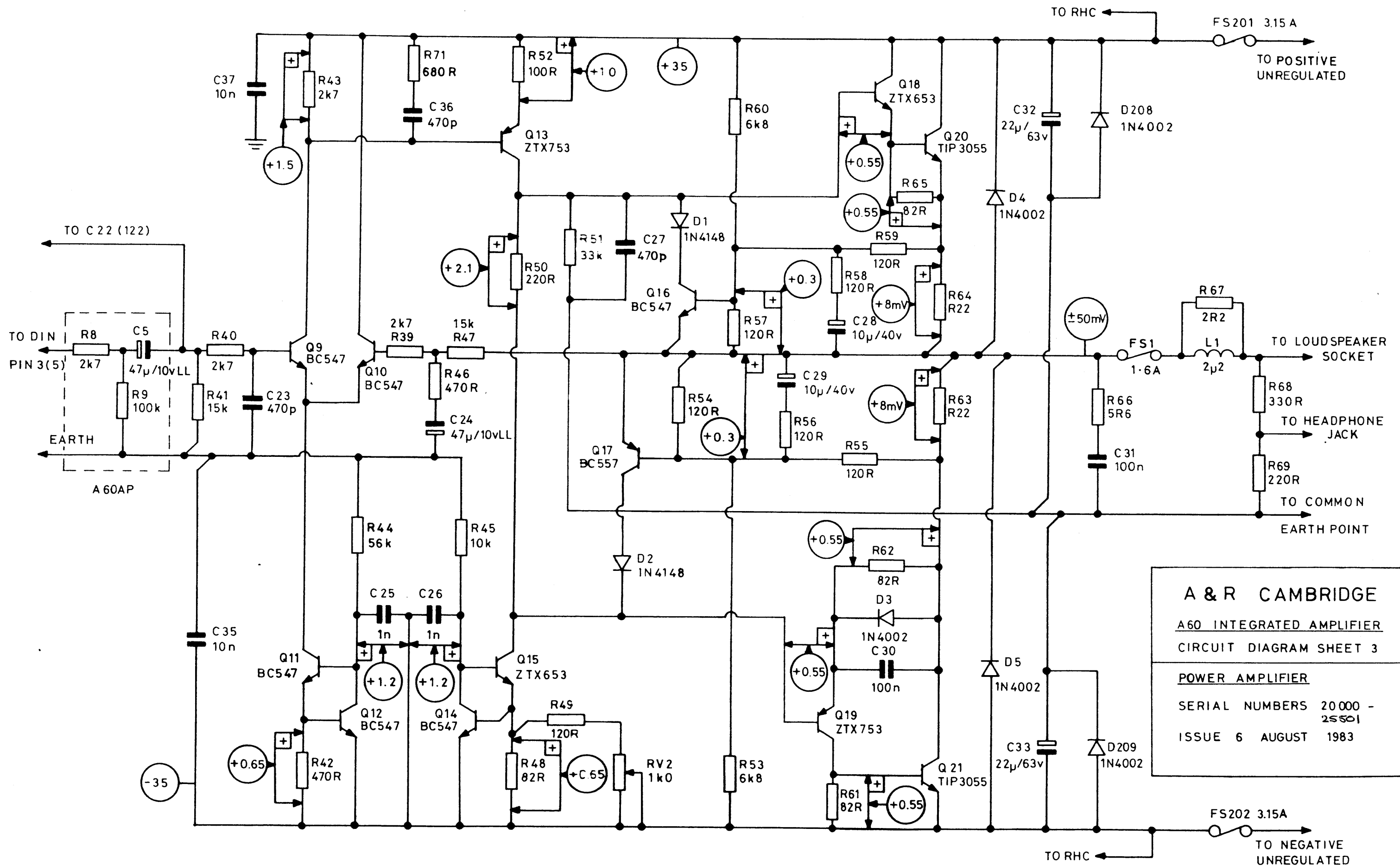

A & R CAMBRIDGE
A60 INTEGRATED AMPLIFIER
CIRCUIT DIAGRAM SHEET 3
POWER AMPLIFIER
 SERIAL NUMBERS 20000 - 25501
 ISSUE 6 AUGUST 1983

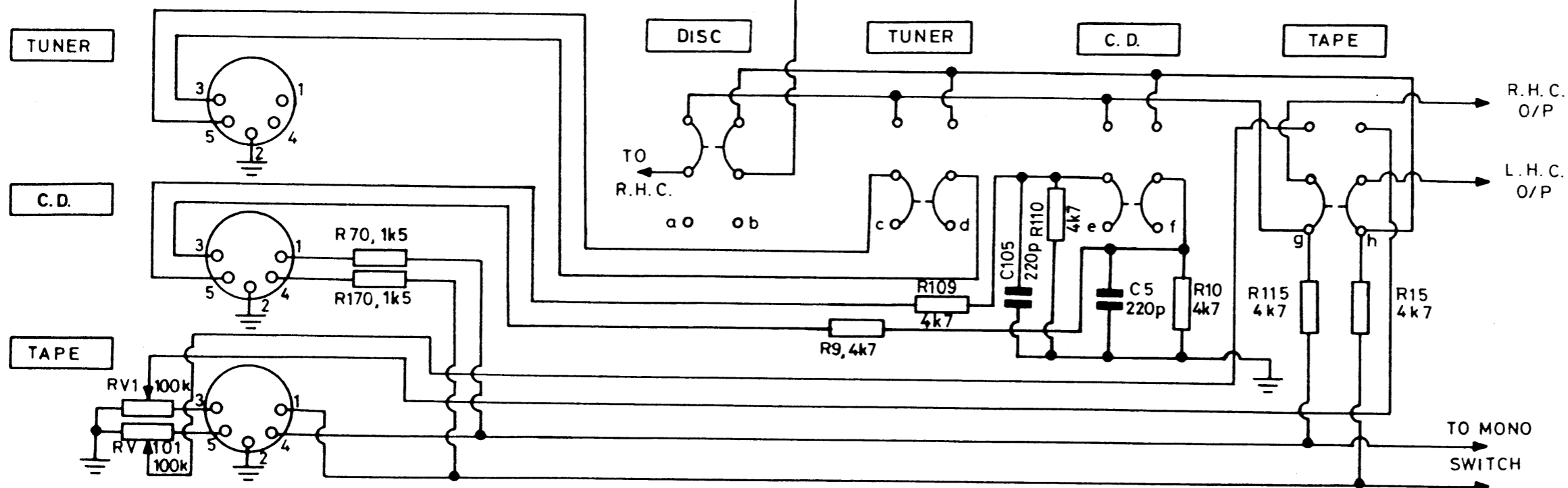
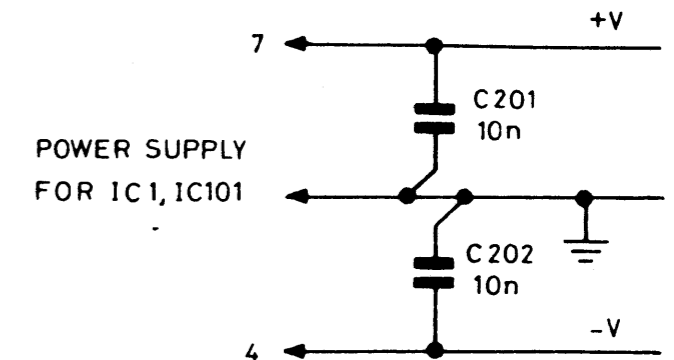
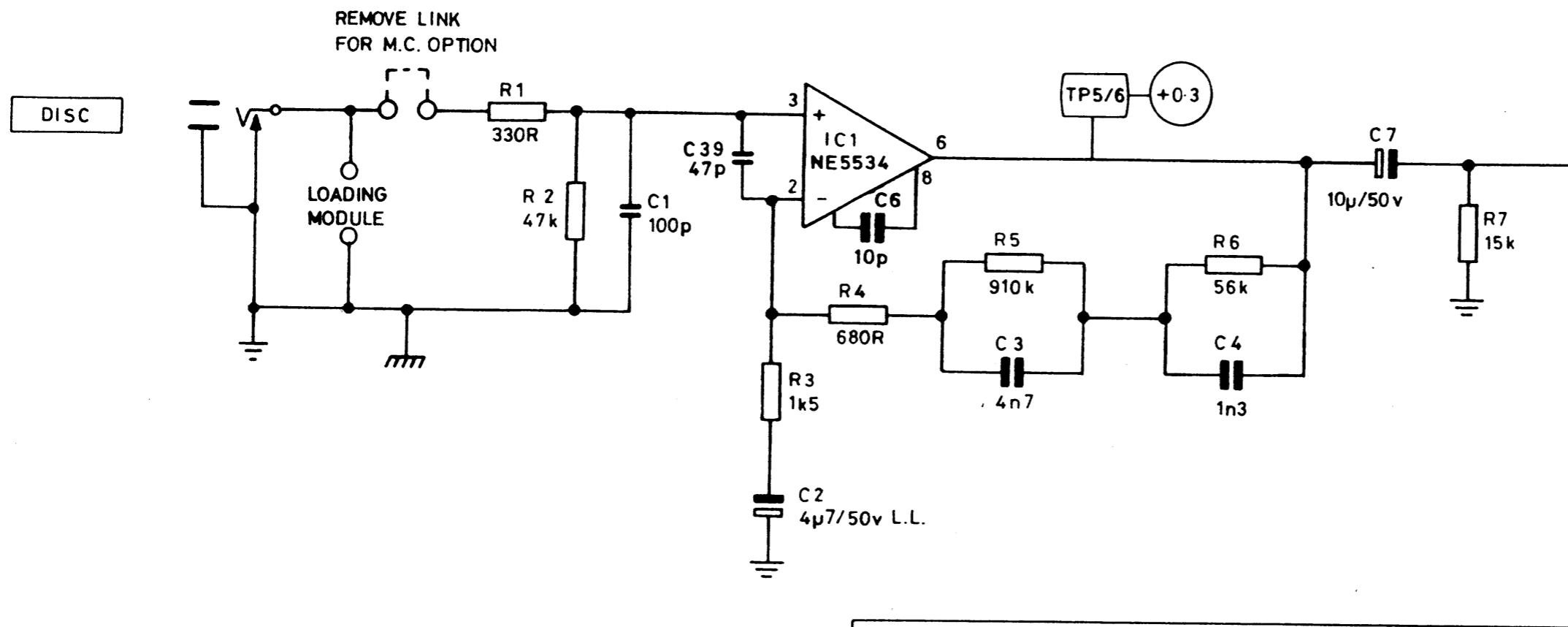

A & R CAMBRIDGE

A60 INTEGRATED AMPLIFIER

CIRCUIT DIAGRAM SHEET 1

DISC INPUT AND SELECTOR
SWITCH

SERIAL NUMBERS 25502-

ISSUE 8 NOVEMBER 1985

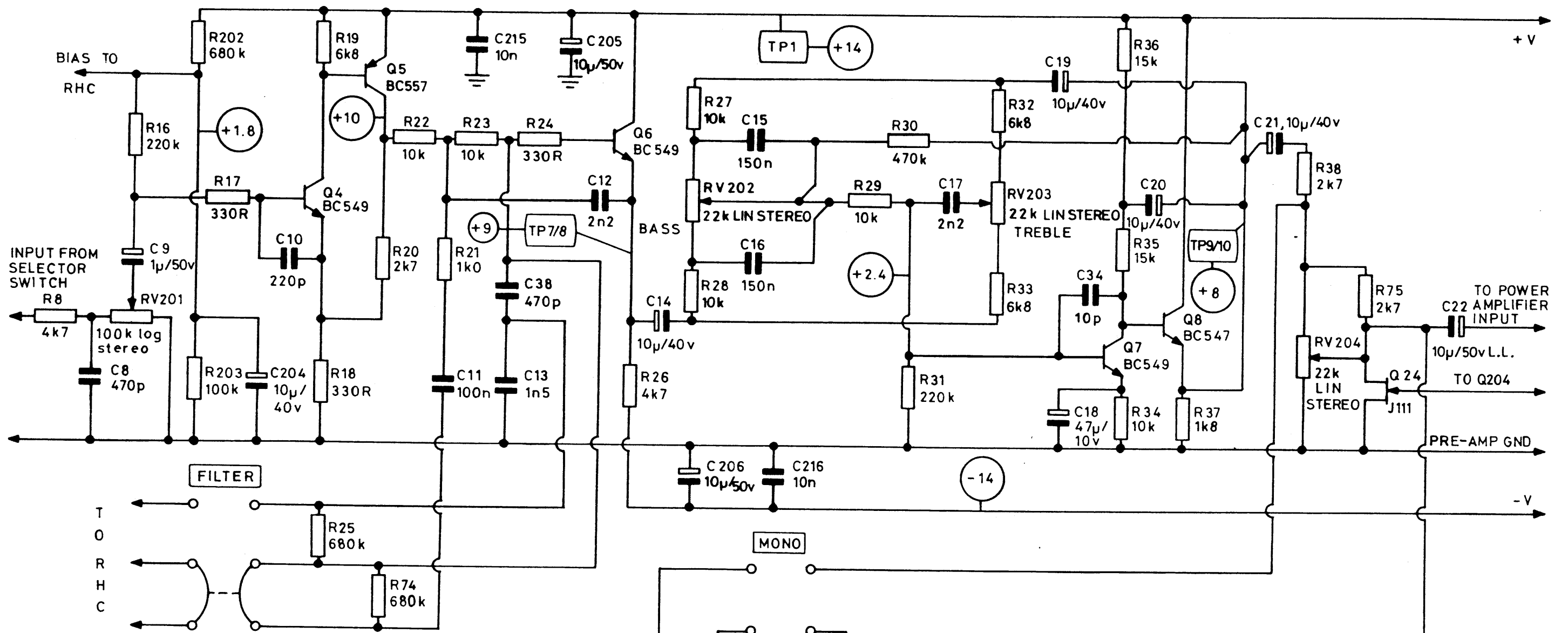

A & R CAMBRIDGE

A60 INTEGRATED AMPLIFIER

CIRCUIT DIAGRAM SHEET 2

PREAMPLIFIER AND TONE CONTROL

SERIAL NUMBERS 25502 -

ISSUE 8 NOVEMBER 1985

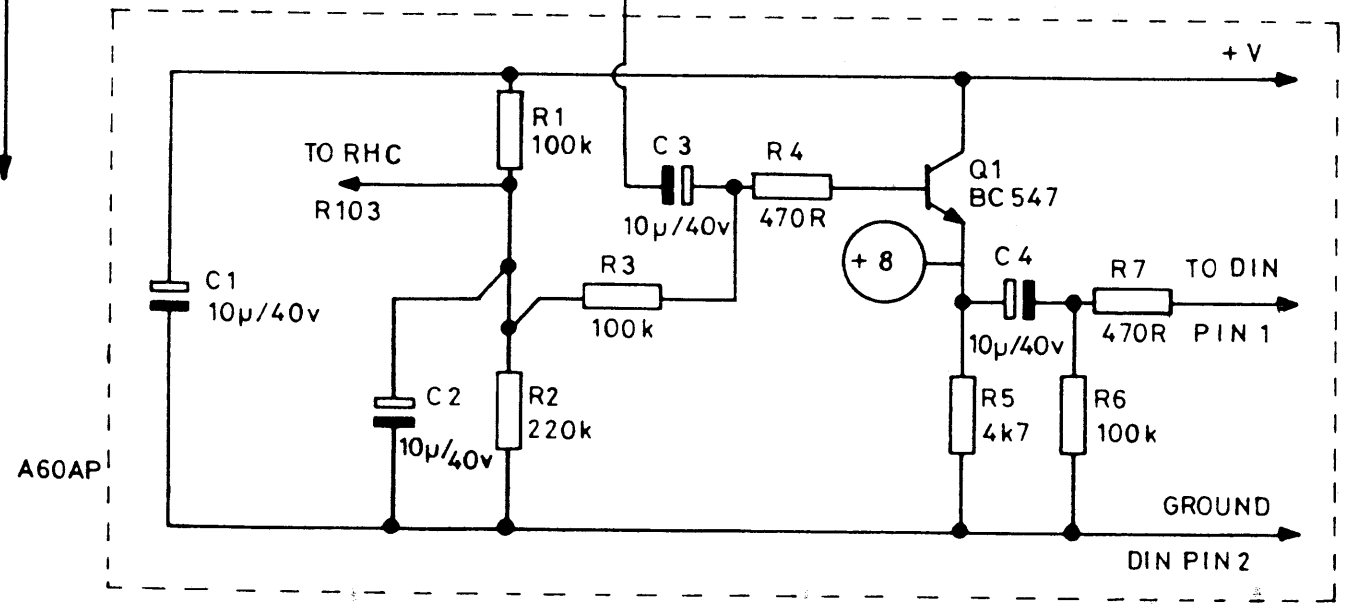

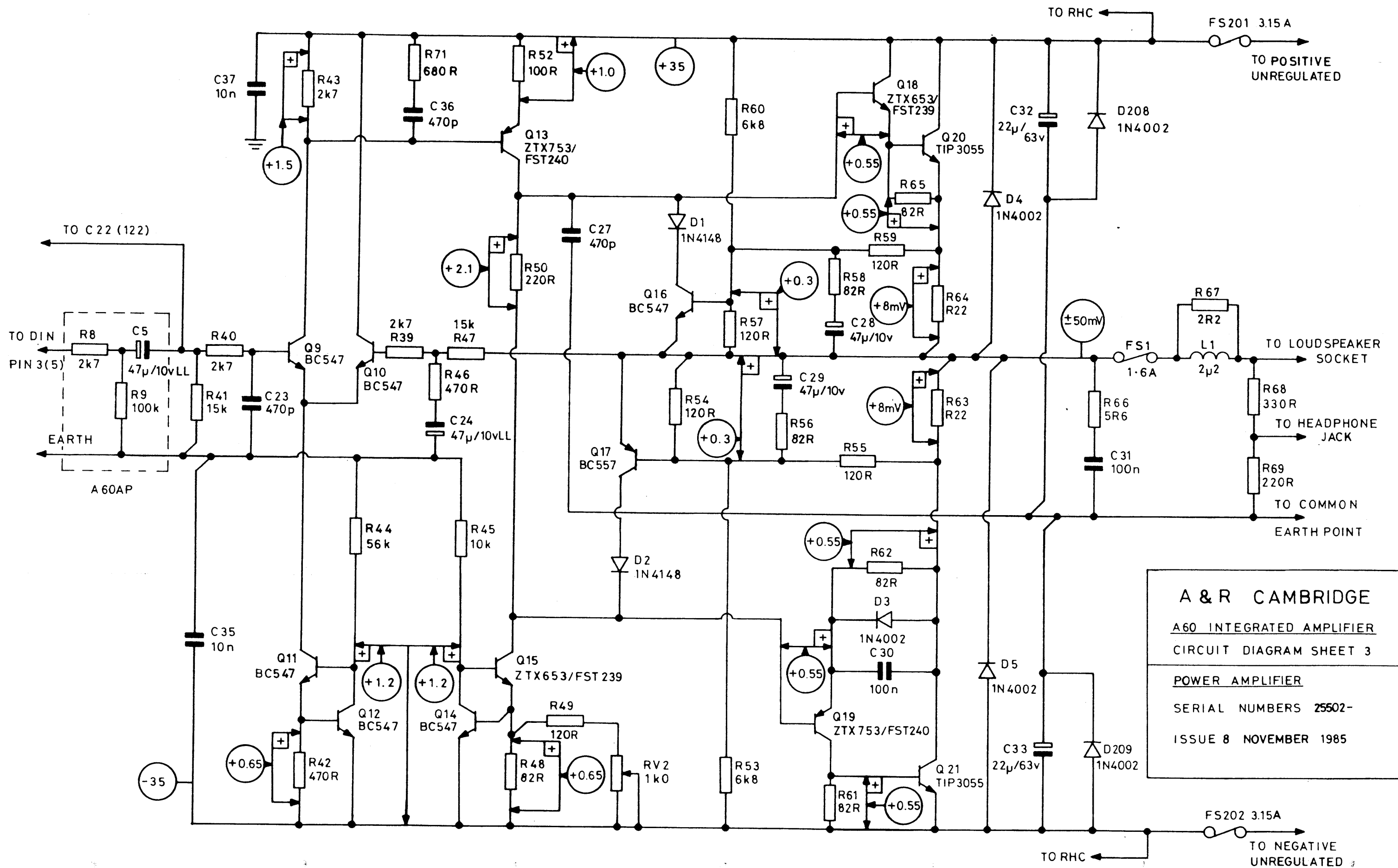

A & R CAMBRIDGE
 A60 INTEGRATED AMPLIFIER
 CIRCUIT DIAGRAM SHEET 3
 POWER AMPLIFIER
 SERIAL NUMBERS 25502-
 ISSUE 8 NOVEMBER 1985

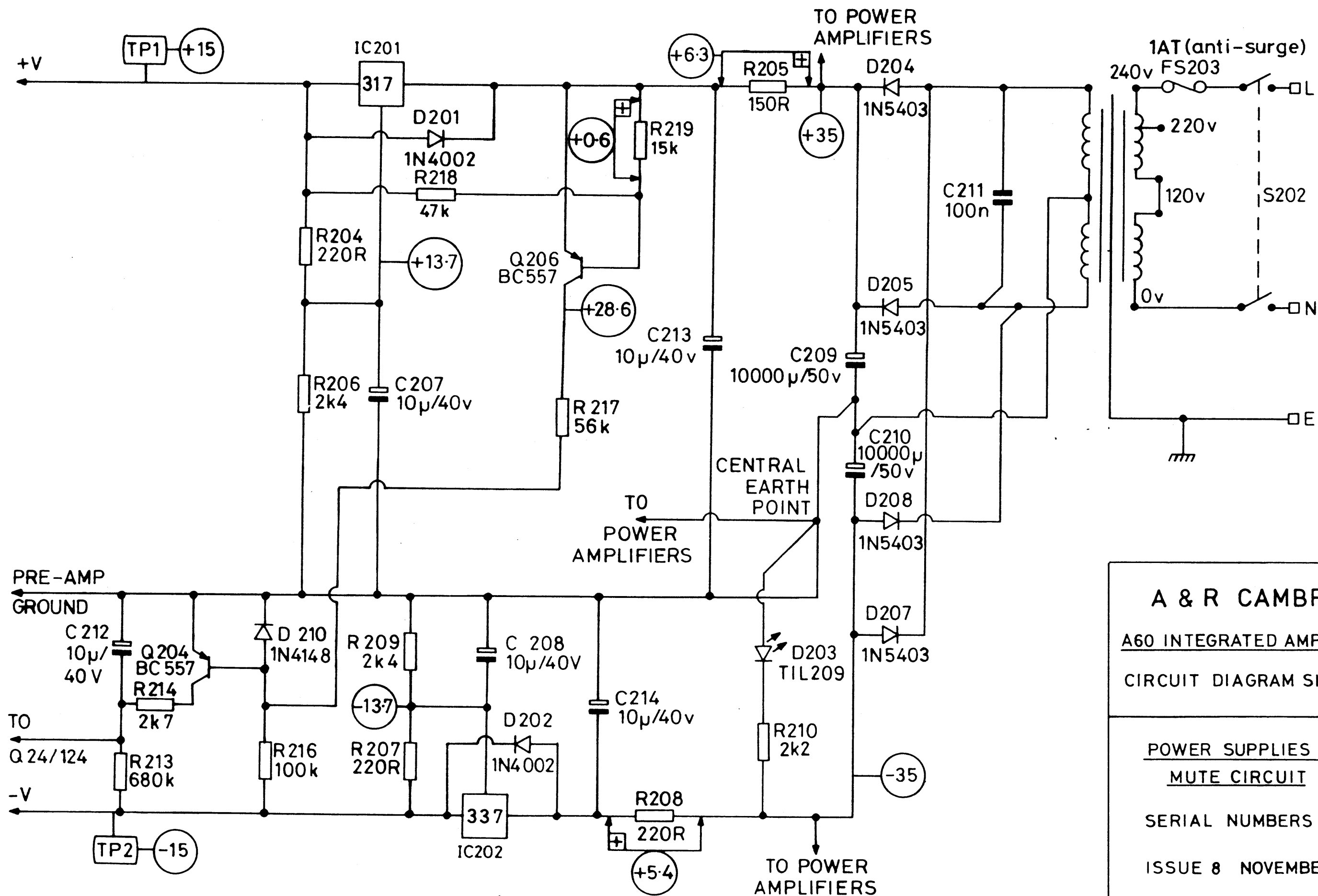

A & R CAMBRIDGE
A60 INTEGRATED AMPLIFIER
CIRCUIT DIAGRAM SHEET 4

POWER SUPPLIES AND
MUTE CIRCUIT
 SERIAL NUMBERS 25502-
 ISSUE 8 NOVEMBER 1985