

Schematic Circuit Diagram of Receiver Using Metal Tubes.

1935-36

MODELS T5-2 AND C5-2 [GENERAL ELECTRIC A-54 AND A-58]

NOTE- WESTINGHOUSE 155A AND 155X SAME AS CIRCUIT BELOW OMITTING WAVE TRAP

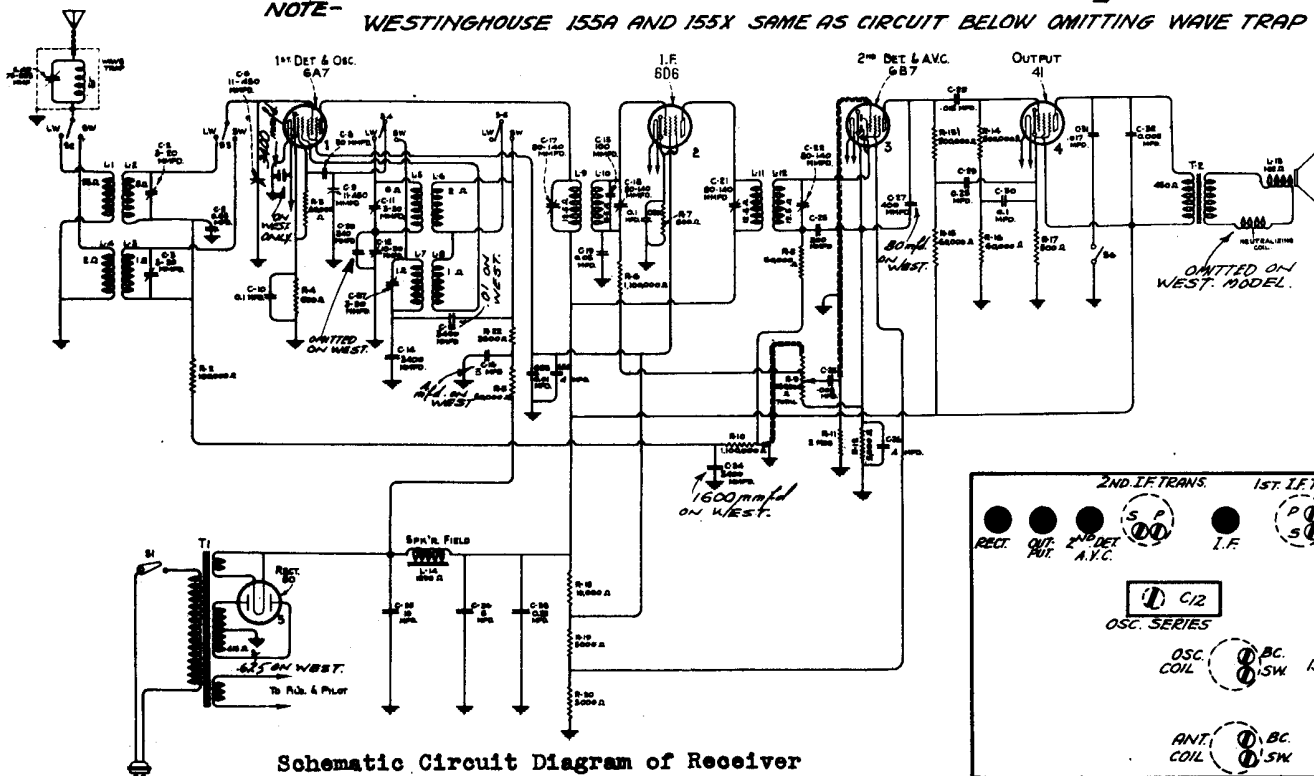

Schematic Circuit Diagram of Receiver Using Glass Tubes.

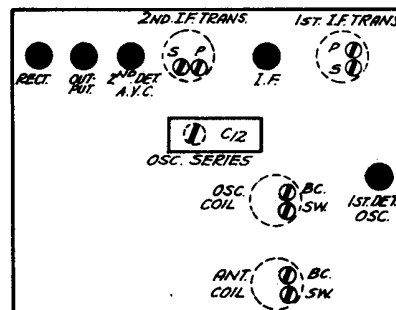

TRIMMER AND TUBE LOCATIONS FOR VICTOR AND GENERAL ELECTRIC MODELS AS ABOVE. WESTINGHOUSE LAYOUT ON DATA SHEET-38.

DATA SHEET

PRINTED IN CANADA

VICTOR-37

VICTOR (ALSO GENERAL ELECTRIC MODELS, H-37 AND H-38)
(ALSO WESTINGHOUSE 155A AND 155X OMITTING WAVE TRAP)

I.F. TUNING ADJUSTMENTS.

Two transformers comprising four tuned circuits are used in the intermediate amplifier. These are tuned to 460 K.C. and the adjustment screws are accessible as shown. Proceeds as follows:

- (a) Short-circuit the antenna and ground terminals and tune the receiver so that no signal is heard. Set the volume control at maximum and connect a ground to the ground terminal.
- (b) Connect the test oscillator output between the first detector control grid and chassis ground. Connect the output meter across the voice coil of the loudspeaker and adjust the oscillator output so that, with the receiver volume control at maximum, a slight deflection is obtained in the output meter.
- (c) Adjust the secondary and primary of the first and then the second I.F. transformers

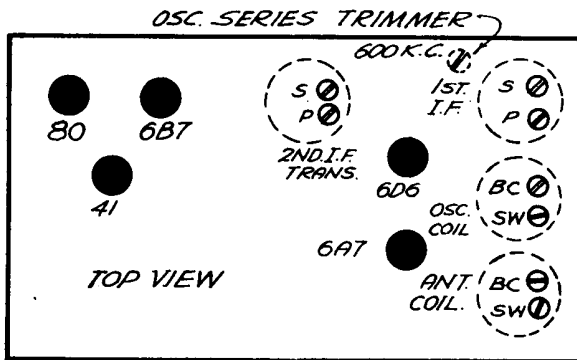

TRIMMER AND TUBE LAYOUT FOR WESTINGHOUSE MODEL 155A AND 155X.

until a maximum deflection is obtained. Keep the oscillator output at a low value so that only a slight deflection is obtained on the output meter at all times. Go over these adjustments a second time, as there is a slight interlocking of adjustments. This completes the I.F. adjustments.

R.F. AND OSCILLATOR ADJUSTMENTS.

The R.F. line-up capacitors are located at the bottom of the coil assemblies instead of their usual position on the gang capacitor. They are all accessible from the bottom of the chassis except the 600 K.C. series capacitor, which is accessible from the top of the chassis.

- (a) Connect the output of the oscillator to the antenna and ground terminals of the receiver. Check the position of the indicator pointer when the tuning capacitor plates are fully meshed. It should be coincident with the radial line adjacent to the dial reading of 540. Then set the Test Oscillator at 1720 K.C., the dial indicator at 1720 and the oscillator output so that a slight deflection will be obtained in the output meter when the volume control is at its maximum position.

*530 ON WEST MODEL.

- (b) With the Range Switch at the "in" position adjust the two trimmers under the two R.F. coils, designated as BC until a maximum deflection is obtained in the output meter. Then shift the Test Oscillator frequency to 600 K.C. The trimmer capacitor, accessible from the top of the chassis, should now be adjusted for maximum output while rocking the main tuning capacitor back and forth through the signal. Then repeat the 1720 K.C. adjustment.
- (c) Now place the Range Switch at the "out" position, shift the Test Oscillator to 18,000 K.C. and set the dial at 18M. Adjust the two trimmer capacitors designated as SW for maximum output, beginning with the oscillator trimmer. It will be noted that the oscillator and first detector trimmers will have two positions at which the signal will give maximum output. The position which uses the lower trimmer capacitance, obtained by turning the screw counter-clockwise, is the proper adjustment for the oscillator, while the position that uses a higher capacitance is correct for the detector. The detector trimmer MUST be adjusted for maximum output while rocking the main tuning capacitor back and forth through the signal. Both of these adjustments must be made as indicated irrespective of output.

The important points to remember are the need for using the minimum oscillator output to obtain a deflection in the output meter with the volume control at its maximum position and the manner of obtaining the proper high frequency oscillator and detector adjustments.

WAVE TRAP ADJUSTMENT: VICTOR & G.E. ONLY

To eliminate code interference in localities near high powered radio telegraph stations operating at frequencies in the vicinity of 460 K.C., a wave trap consisting of a parallel resonant circuit is incorporated in these receivers.

With receiver in operation using its normal antenna tune, the station selector to the point at which the intermediate-wave interference is most intense. Then adjust the wave-trap trimmer to the point which cause maximum suppression of the interference.

DATA SHEET

PRINTED IN CANADA

COURTESY-R.C.A.

VICTOR-38