

58

# CARVER

P R O F E S S I O N A L

This service manual is  
also for:

PT-1250

## PM 2.0t

### SERVICE MANUAL

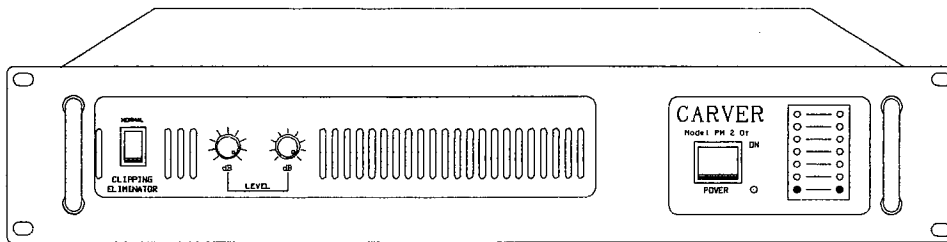

*Powerful*

*Musical*

*Accurate*

Carver PM 2.0t

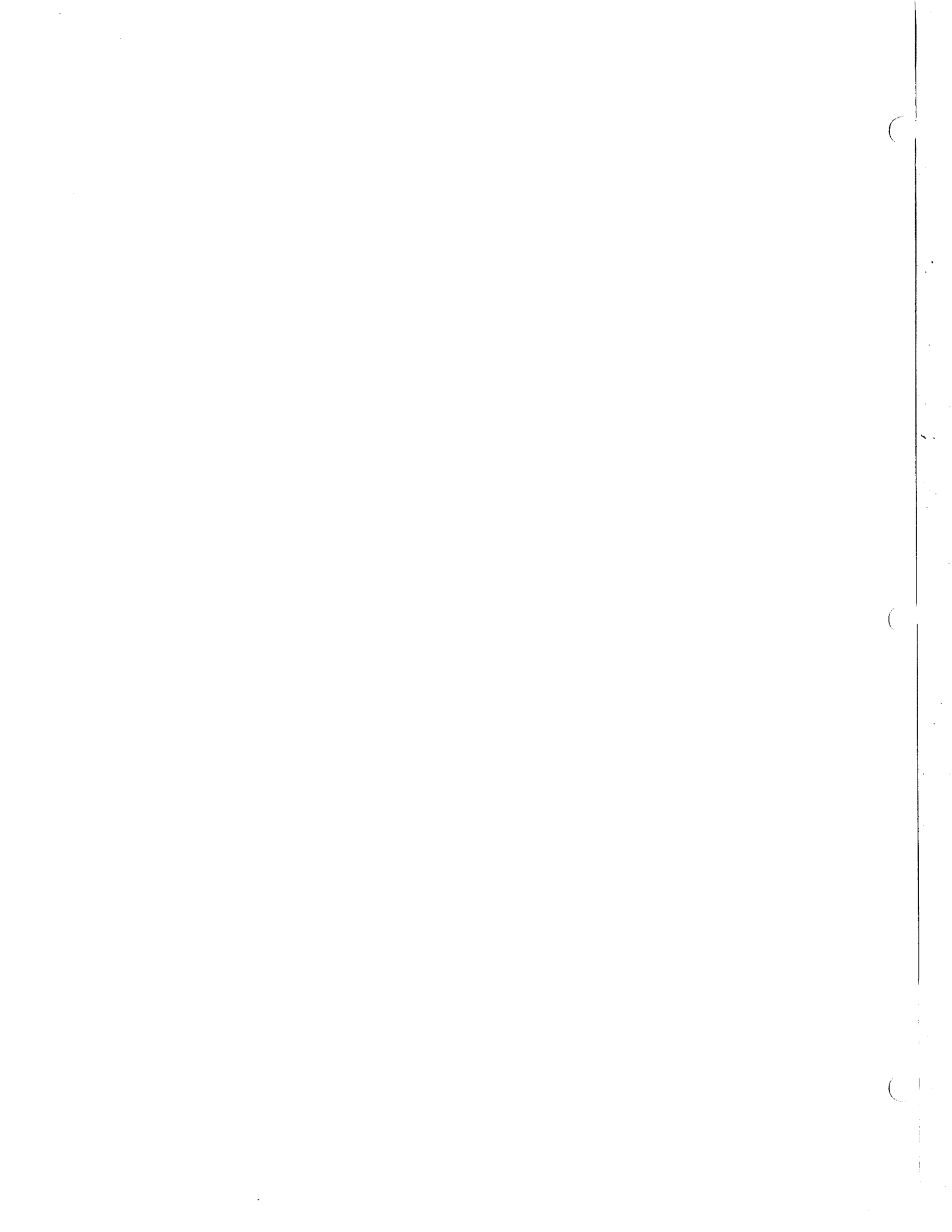

**CARVER**  
PROFESIONAL

PM 2.0t  
SERVICE MANUAL

---

---

CONTENTS

Introduction	1
Power supply circuit description	2
Amplifier circuit description	4
Primary board low voltage check points	5
Power supply line test procedure	7
Amplifier test procedures	8
Bias adjustment	8
Null adjustment	9
Amplifier test points and limits	9
Circuit board interconnections	12
Power supply block diagram	13
Power supply schematic	14
Power supply schematic (European)	15
Schematics and board layouts	16
Power supply waveforms	25
Amplifier waveforms	28
Specifications	29
Appendices	30
Parts lists	35
Notes	36

---

---

INTRODUCTION

The intent and scope of this manual is primarily concerned with the PM 2.0t power supply and it's operation and interaction with the amplifier. An assumption has been made that the technician is familiar with Carver Magnetic Field amplifiers and will have little difficulty with that portion of the PM 2.0t. The power supply, however, is totally different from other Carver amplifiers and is capable of causing a considerable amount of frustration without an understanding of it's basic operating principals. Before attempting any repairs on this power supply, the circuit description, timing diagrams and low voltage test procedures of this manual should be read first. With a working knowledge of what makes it "tick" the PM 2.0t is actually quite tame. Almost any problem encountered can be resolved with the low voltage tests outlined in this manual.

Any service performed on the power supply when it is line connected must take into account the WARNINGS and CAUTIONS outlined in this manual in order to avoid serious shock hazard and/or damage to test equipment!

PM 2.0t  
POWER SUPPLY CIRCUIT DESCRIPTION

**WARNING**

WHEN SERVICING THE POWER SUPPLY PRIMARY CIRCUIT  
AN ISOLATION TRANSFORMER MUST BE USED ! ! !  
A SERIOUS SHOCK HAZARD AND POSSIBLE DAMAGE TO  
EQUIPMENT EXISTS IF THIS PRECAUTION IS NOT FOLLOWED

When the power switch SW-1 is closed, capacitors C4 & C5 are charged to 160 Vdc and C6 begins to charge thru R3. C4 & C5 are the high voltage source for the switchers and C6 is the low voltage supply for the control circuitry and switcher drive.

When C6 has charged up to approximately 7-8 volts the regulated 5 volt supply from U1 is stable and the internal oscillator is running. The output of U2-A is high and, thru D7, forces the output of U2-C high. This blocks the reset pulses from U1 pin 7 and inhibits the drive output of U1 pins 11 and 14.

When the voltage on C6 reaches approximately 22-24 volts it causes U2-A to toggle low. This allows the reset pulses from U1 pin 7 to toggle the output of U2-C to it's low state. With U2-C low, the PWM outputs are active and either Q4 or Q5 will receive a drive signal and in turn force the main switchers Q6 or Q7 on.

With the power supply secondary capacitors in a discharged state, Q6 & Q7 will, in effect, see a short circuit. The charging current will be limited only by the primary leakage inductance and winding resistance of the transformer. To prevent switching transistor failure, a voltage proportional to the collector current is developed across R61 and fed to the + input of U2-B. When a predetermined voltage appears across R61 it causes the output of U2-B to go high. This sets the output of U2-C to it's high state and disables the outputs of U1. Because of the hysteresis circuit around U2-C, it's output will remain high until a reset pulse from U1 pin 7 toggles U2-C low again, which will allow the opposite switcher to turn on.

This sequence of switcher on - over current shutdown will continue for several seconds until the secondary capacitors have charged up to a point where they no longer appear as a short circuit to the primary drive circuit.

With the power supply up and running, no over current pulses appear at the + input of U2-B and the output of U2-C remains in the low state allowing the PWM outputs of U1 to function normally.

With the power supply running, RP1 is adjusted for a no load "on time" of 60 to 80  $\mu$ sec. The duty cycle is set low to minimize mechanical noise and temperature rise in the transformer due to iron losses. When the current requirements increase, as the amplifier is driven harder, the voltage across R61 increases proportionally and is integrated by C21. This integrated voltage from R61 is applied to the + input of the internal transconductance amplifier of U1 which controls the duty cycle. As the voltage goes up, the duty cycle increases to provide the power required by the amplifier.

The low voltage supply winding and D18 thru D21 provides the drive current for Q6 & Q7. Since the power supply is current regulated, this low voltage supply is used for high current drive requirements and housekeeping only. It is not associated with voltage regulation.

## CIRCUIT REFINEMENTS

Because of transistor storage, rise and fall times the switchers do not turn on and off at the exact same time as the drive signals from the regulator IC. If the turn off times are not fast enough, the main switchers could go into simultaneous conduction at full duty cycle or during the start sequence, greatly exceeding their current ratings due to the very high current rise time. Either of these two conditions could cause a failure of the system.

To prevent these conditions from occurring, current limiting and speed up circuits are incorporated. During the start up sequence, Q2 and Q3 are turned on by the pulse train from U2-C. Q3 lowers the over current trip point of U2-B and Q2 "stretches" the idle duty cycle during the transition from "over current" start up to the normal run mode. Both circuits reduce peak collector currents in the switchers.

To speed up the turn off time of the drivers and main switchers Q1 is forced on when either of the internal output transistors of U1 switches off. With Q1 on, the bases of the driver transistors, Q4 & Q5, are clamped to ground via D9 and D10. On the main switchers Q6 & Q7 the diode resistor networks of D12,D13,R64 and D16,D17,R65 form base drive "feed forward" circuits which keep Q6 and Q7 operating in the active mode. Although operating switching transistors in their active area of operation is not as efficient, in some aspects, as saturated operation it simplifies the drive circuitry by eliminating the need for reverse base drive. Also, by using a feed forward drive circuit, the dissipation of both the drivers Q4,Q5 and main switchers Q6,Q7 is greatly reduced since they require only enough base drive to turn on under light load conditions. As the load requirements go up, the drive required increases **only as required** to maintain proper operation. The overall system efficiency is greater than that obtained with a forced gain - saturated mode switcher.

Diodes D14 & D15 prevent high voltage from appearing in the low voltage drive circuitry in the event of a switcher failure.

Because of the low value of R61 (.008  $\Omega$ ) and the high gain of the regulator U1, R26 and D6 are included for temperature compensation to stabilize the idle duty cycle.

Capacitors C31,32 & 33 are included to null out circulating ground currents which could possibly get into mixers or other low level support equipment in the complete system.

A trickle charge circuit for the line capacitors C4,C5 is provided by R2 and D3 when the power switch is off. This eliminates large inrush currents which could possibly damage the power switch.

The hysteresis circuit built around U2-A will shut down the entire power supply if the low voltage drive falls below 8 volts. This keeps the regulated 5 volt supply functioning and ensures enough drive current to hold Q6 & Q7 on under full load -low line conditions. Should the low voltage supply fall below this point, the power supply cycles back to a start sequence.

The opto-coupler U3 provides primary to secondary isolation for shut down commands from the amplifier board. As with the low voltage shut down circuit, any fault signal from the amplifier will cause the power supply to reset to the start sequence.

NOTE: Since the primary drive has very limited output capability during the start sequence, any amplifier failure mode which draws more than 50 to 75 watts will prevent the supply from going into the run mode. While this can make troubleshooting more difficult, it does prevent further damage to the amplifier or speakers if a failure does occur.

## POWER SUPPLY REVISIONS

Beginning with serial number PS1006, a number of changes were made to improve overall performance. The most significant change being the snubber network (C27 & R62). This change increases the flyback energy absorbing capability by a factor of five and consequently the overall reliability under adverse conditions is improved. Refer to appendix A for these changes and updating procedures.

### 230 VOLT (EUROPEAN VERSION) POWER SUPPLY

In mid year 1989, a 230 volt version of the PM-2.0t was introduced. Refer to the European version schematic and Appendix B for the circuit changes. All test procedures for the 120 volt PM-2.0t apply to this unit. Due to the fact that the switching transistors Q6 & Q7 have half the current rating of the domestic PM-2.0t, it is not possible to make a voltage change between these two versions. If voltage conversion is absolutely necessary, it can be accomplished only by changing the entire power supply module.

#### PM 2.0t AMPLIFIER CIRCUIT

The power amplifier section of the 2.0t is very similar to the PM 1.5 series. The primary differences in the PM2.0t are input muting, the addition of a fourth power supply rail, the power supply shut down circuitry and parallel mono operation. This section will deal only with these areas.

Because the power supply has very limited output capability during the start up phase, the signal input to the amplifier must be muted momentarily to allow the supply to complete it's start cycle and toggle into the high power mode. This is accomplished with the muting FETs Q134/Q334 and the drive circuit of Q2.

When the amplifier is turned on, the gate to source voltage on the muting FETs is zero which puts the FETs in a low resistance on state. Since they form a voltage divider with R101/R301, the signal level to the input of U1 is attenuated  $\approx 35\text{dB}$ .

As the power supply comes up to full power operation, the emitter of Q2 is "hard" biased to -12V. With C7 across the base-emitter junction, this transistor remains in the off state momentarily which allows the muting FETs to stay on. As C7 discharges through R5 & R6, transistor Q2 turns on causing the collector voltage to swing negative which turns the muting FETs off. If a fault condition shuts the power supply down or the amplifier is turned off, diode D3 provides a rapid discharge path for C7 and resets the mute FETs to their on state.

The following fault conditions will cause the power supply to shut down.

- a) A short circuit at the amplifier output:
- b) DC offset voltage at the output terminals:
- c) Temperatures in excess of  $100^{\circ}\text{C}$  at the output transistors:
- d) Excessive out of band high frequency output:

Under short circuit conditions, Q1 on the Amplifier circuit board is turned on which activates Q7 on the power supply Secondary circuit board. With Q7 on, a conduction path for the LED section of U3 on the Primary circuit board is completed causing the power supply to shut down and recycle to the start sequence.

DC offset conditions cause the power supply to shut down by acting on Q1 on the Secondary board. If the offset voltage is positive, Q1 operates in a common emitter mode with the ground return path through D4. If the offset voltage is negative, Q1 functions as a common base circuit. In this condition the base is held at ground potential by R11 and the emitter is "pulled negative" through D3. Diodes D3,D4 and D13 function as steering diodes depending on whether the fault voltage is positive or negative.

A high temperature shut down acts directly on the power supply control circuit through thermal switch SW-2. Because this thermal switch is in series with the power switch SW1-B it has the same effect as turning the unit off.

NOTE: the thermal switch acts only on the power supply control circuitry, it does not carry any load current.

A fourth power supply rail and the associated commutator circuits have been added to increase overall operating efficiency. Unlike the tracking commutators for the  $\pm 55$  and  $\pm 80$  volt supplies however, the  $\pm 125$  volt commutators toggle or "snap" on and off. Since these transistors are either on or off during operation, their power dissipation is very low. The operating reference voltage for these commutators is formed by R137/D120 and R143/D131 in the emitter legs of Q107 and Q111. With the reference voltage derived from the  $\pm 80$  volt supplies through Zener diodes D120 and D131, a constant voltage "lead" is maintained for the output transistors regardless of power supply ripple or line voltage variations.

The  $\pm 125$  volt commutators are active when the amplifier output voltage forward biases Q107 or Q111 through diodes D108/D110. Since all the transistors in the these commutator circuits are operated in a forced gain mode, the voltage drops across the power transistors Q118/119 and Q129/130 are held to a minimum at high output currents.

PM 2.0t  
**PRIMARY BOARD LOW VOLTAGE CONTROL CIRCUIT CHECK**

Due to the fact that things happen very quickly with switching power supplies, a low voltage external power supply should be used for all repairs or troubleshooting on the primary circuit board. Any supply with a variable output voltage range of 0 - 35 volts @ 500 mA can be used for this procedure.

By using an external voltage source it is possible to check all aspects of the primary circuitry, including the main switchers, without any exposure to potential shock hazards. It is also possible to locate control circuit problems which could damage the high voltage switchers if normal "replace the bad part and turn the variac up" repair methods are used.

**It is strongly recommended that this method of troubleshooting be used when performing any repairs on the control circuitry of the PM 2.0t.**

**CAUTION**  
THE PM 2.0t MUST **NOT** BE CONNECTED TO  
A 120 Vac SOURCE FOR THESE TESTS!

NOTE: Capacitors C4 and C5 MUST be discharged before any low voltage tests are performed!

- 1] Initial setup with the power supply bottom cover removed:
  - a) Check base resistors R58 and R 60 for a  $3.9\Omega$  reading.

2] Set the external supply to "zero" output and connect the negative lead to the ground side of R61 (use the tubular terminal next to R61) and the positive lead to the cathode of D19 or D21.

3] Turn the PM 2.0t power switch on.

4] Set the output of the external supply to 8 volts and check:

- a) Oscillator ramp output of U1-7  $\approx$  3V p/p 450-500  $\mu$ sec period. (Fig 4)
- b) U2-9 positive 2.8 volts with .6 volt negative reset pulse (Fig 6).
- c) U2-14 4 volts positive.
- d) U2-1 output low
- e) U1-10 1 volt positive.
- f) U1-11 & 14 no output drive.
- g) U2-6  $\approx$  150 mV positive.
- h) U1-16 5 volts regulated  $\pm$  5%.
- i) Base of Q2 & Q3 .7 volts positive.

5] Increase the voltage from 8V to 25V and check:

- a) U2-13 output low
- b) U2-14 output low
- c) U1-16 5 volts regulated  $\pm$  5%

6] Decrease the supply output to 15 volts and check or adjust:

- a) Adjust RP1 for a duty cycle of 60  $\mu$ sec at U1-11 & 14.
- b) Output amplitude of U1-11 & 14  $\geq$  2.7 volts positive (Fig 2).
- c) Emitters of Q4 & Q5 for  $\approx$  2.1 volts positive output.
- d) Base of Q1 pulse of  $\approx$  7 volts negative to 1 volt positive (Fig 1).
- e) Base of Q2 & Q3 zero volts.
- f) U2-6 380 mV maximum.
- g) U10-1 output low
- h) Check the base of Q4 and Q5 for a drive pulse amplitude of  $\approx$  2.7 volts positive (Fig 2)
- i) Check the base of Q6 and Q7 for a drive pulse amplitude of  $\approx$  1.4 volts positive.

7] Decrease the supply output to 7 volts and check:

- a) U1-10 1 volt positive.
- b) U1-11 & 14 no output.

8] Reduce the 0 - 35 volt supply to 0V and connect the positive lead to the collector of Q6 or Q7. Set the output voltage to 35 volts and check for:

- a) No current draw from the external power supply.



**WARNING**

IF THE MAIN SWITCHERS Q6 - Q7 OR THEIR DRIVERS Q4 - Q5 HAVE BEEN REPLACED, THE ELECTRICAL ISOLATION OF THEIR COLLECTORS TO THE HEAT SINK **MUST** BE CHECKED TO ELIMINATE ANY POSSIBLE SHOCK HAZARD TO THE USER OR TECHNICIAN !

If the tests listed above are within the specified limits and the main switchers are good or have been replaced, continue on to the line test procedure.

NOTE: IF ANY POWER SUPPLY TROUBLESHOOTING IS PERFORMED WITH THE PM 2.0t POWERED WITH 120 Vac. **AN ISOLATION TRANSFORMER MUST BE USED!**

PM 2.0t

POWER SUPPLY LINE TEST PROCEDURE

1) Initial power-up settings:

- a) Replace the power supply MDL 10 Amp fuse with a 1¼ Amp AGC.
- b) Signal source connected to TRS or XLR inputs.
- c) 8Ω loads on both channels.
- d) Power switch OFF.
- e) Input level controls fully off (CCW).
- f) Signal source at zero output.
- g) Fan speed switch in Hi position.

With the power switch off, bring the Variac up to 120 Vac. There should be no current draw and the power LED should glow dimly.

Reduce the line voltage to  $\approx 95$  Vac and turn the PM 2.0t ON. The power LED should glow brightly and the supply itself should start within  $\approx 15$  seconds. The "ready" LED's will turn on 2 to 4 seconds later and the idle current should be less than 600 mA. Both fans should be running at the same speed.

Increase the line voltage to 120 Vac and, at the junction of R1 - R2 on the amplifier circuit board, adjust RP1 on the power supply primary board for maximum duty cycle and check for shutdown, or excessive line current.

Using a non conductive tool adjust RP1 for a duty cycle of 60 to 80  $\mu$ sec and place a new paper "dot" over the access hole of RP1.

**CAUTION !**

When adjusting the duty cycle, if RP1 is turned to the point where the power supply shuts down  
--- **TURN THE PM 2.0t POWER SWITCH OFF** ---  
and reset RP1 to mid-position before restarting.

For the remaining tests, replace the 1¼ amp AGC fuse with a 10 amp slow blow MDL type fuse.

With the amplifier set for an output of 10 volts RMS, short the output of either channel. The power supply must shut down and restart when the short is removed.

Drive both channels to maximum power into 8 Ohms and reduce the line voltage to 80 Vac. The amplifier must not shut down.

Drive both channels to maximum power into 4 Ohm loads at 120 Vac. The amplifier must not shut down.

PM 2.0t  
AMPLIFIER TEST PROCEDURES

1] Initial power-up settings

- a) 8Ω loads on both channels.
- b) Signal source connected to TRS or XLR inputs.
- c) Power switch OFF.
- d) Clipping eliminator switch OFF.
- e) Input level controls fully ON (CW).
- f) Signal source at zero output.
- g) Fan speed switch in the Hi position.
- h) Amplifier fused with a 10 amp slow blow MDL fuse.

With the power switch off, slowly bring the Variac up to 120 Vac. There should be no current draw and the power LED should glow dimly.

Reduce the line voltage to ≈ 95 Vac and turn the PM 2.0t ON. The power supply should start within 15 seconds and the green "ready" LED's should come on 2 to 4 seconds later. The unit should not draw any current and both fans should be running at the same speed.

Increase the AC line voltage to 120 Vac and adjust the signal generator for an amplifier output of 1 volt RMS at 2Khz. While observing the output wave forms, rotate each bias pot from the maximum to minimum position. In the maximum position the crossover notch should totally disappear and the fan speed should increase. In the minimum bias position, the notch should be quite visible.

BIAS ADJUSTMENT

Set the bias adjust pots RP102 and RP302 for 2 to 3 mV between the emitters of Q123 - Q125 (left ch.) and Q323 Q325 (right ch.)

The bias can also be set visually by observing the distortion trace of a 2kHz signal at 1 volt RMS into an 8Ω load. With this method, reduce the bias current until the crossover notch is clearly visible. Slowly increase the bias until the notch disappears then decrease the bias level until the notch is just visible. To confirm the correct bias current, check the voltage across the emitters as described above.

NOTE: To correctly set the bias, the amplifier must be allowed to warm for a few minutes and there must be no signal output when measuring the bias voltage. Do not set the bias when the amplifier is hot.

## NULL ADJUSTMENT

With the bottom cover removed and the amplifier running, connect a 2k $\Omega$  resistor between the amplifier chassis and a "hard" earth ground. Set the oscilloscope for 5 mSec/div and 1 V/div gain. With the probe across the 2k resistor and adjust C32 on the power supply board to null out the residual 1kHz switching noise. If a good null cannot be obtained, add a ceramic trim cap to the tubular terminals located next to the trim capacitor C32. The value range for this part should fall within 10-50pF. **AN INSULATED SCREW DRIVER MUST BE USED FOR THIS ADJUSTMENT!** Refer to Figure 1 on page 10 for the location of C32. After this adjustment is completed, cover the access hole with a new paper "dot".

## PM 2.0t

### AMPLIFIER TEST POINTS AND LIMITS

#### FREQUENCY RESPONSE

Adjust the amplifier gain controls for 2 volts RMS output at 2Khz. The frequency response must be within  $\pm .5$  dB from 20Hz - 20Khz.

#### COMMUTATORS

Increase amplifier output to 45 volts RMS at 2Khz into 8 Ohms. and check:

Positive wave forms at the collectors of Q123,122,121. Negative wave forms at the collectors of Q125,126,127.

The wave forms should appear as shown in figures 10, 12 and 14. Repeat this test for the right channel.

Increase the signal generator frequency to 10 KHz and recheck the above test points.

The wave forms should appear as shown in figures 11, 13 and 15.

Repeat this test for the right channel.

#### FULL POWER CHECK

Power  $\geq$  500 watts with both ch. driven into 8 $\Omega$  loads at 2Khz. Power  $\geq$  700 Watts with both ch. driven into 4 $\Omega$  loads at 2Khz.

#### HIGH FREQUENCY SHUTDOWN

The amplifier must not shut down at full power at 10Khz. At 20Khz the unit must not shut down at a power level of 200 watts or less.

#### SHORT CIRCUIT SHUTDOWN

At an output level of 10 volts RMS, short each channel and check for power supply shut down.

#### LOW LINE SHUTDOWN

With both channels driven to clipping at 2Khz, reduce the AC line to 80 volts. The unit must not shut down.

#### DC OFFSET SHUTDOWN

Apply +12 volts to the junction of R103/R104 and R303/R304 on the amplifier board. The power supply must shut down.

Repeat this step by applying -12 volts to these junctions. The power supply must shut down.

### CLIPPING ELIMINATOR

With the amplifier just below clipping at 2Khz, increase the input signal level 6 dB. When the clipping eliminator is switched on the clipping LED's must go off and the output distortion must be  $\leq 3\%$ .

### IHF PULSE CHECK

Drive the amplifier to full power with an IHF pulse signal. The output display LED's must track within 1 LED.

### DISPLAY TRACKING

Run the amplifier from zero to full power output. The display LED's must track within 1 LED.

### NOISE CHECK

With the inputs terminated, the "A" weighted noise level must be  $\leq 500 \mu\text{volts}$ . With the inputs open circuit the noise level must be  $\leq 800 \mu\text{volts}$ . The "A" weighted S/N ratio must be  $\geq 110 \text{ dB}$  relative to the rated  $8\Omega$  power output.

### TURN OFF THUMP

With no signal at the input, the turn off thump must be  $\leq 2 \text{ volts DC}$ .

### TURN ON MUTE

Set the amplifier output to 300 Watts per channel. Turn the unit off and then on again. The amplifier must restart without any oscillation in the output waveform.

### HIGH POT TEST

Set the Hi-Pot to 1200 volts and turn the PM 2.0t power switch on. With one probe on the chassis, make contact with each of the line cord blades with the other probe. The unit must not fail. If a Hi-Pot failure occurs the unit cannot be shipped or returned to the customer until the fault condition is corrected.

Location of Duty cycle and Null adjustments

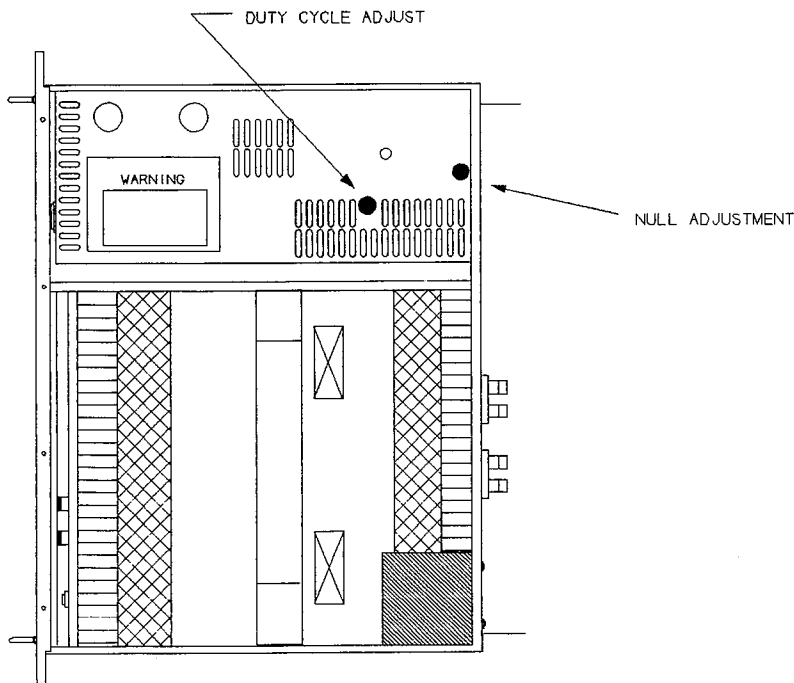

AMPLIFIER BOTTOM VIEW BOTTOM COVER REMOVED

**CARVER**

**PT-1250**

**SCHEMATICS AND LAYOUTS**

**Please add to PM-2.0t Service Manual**

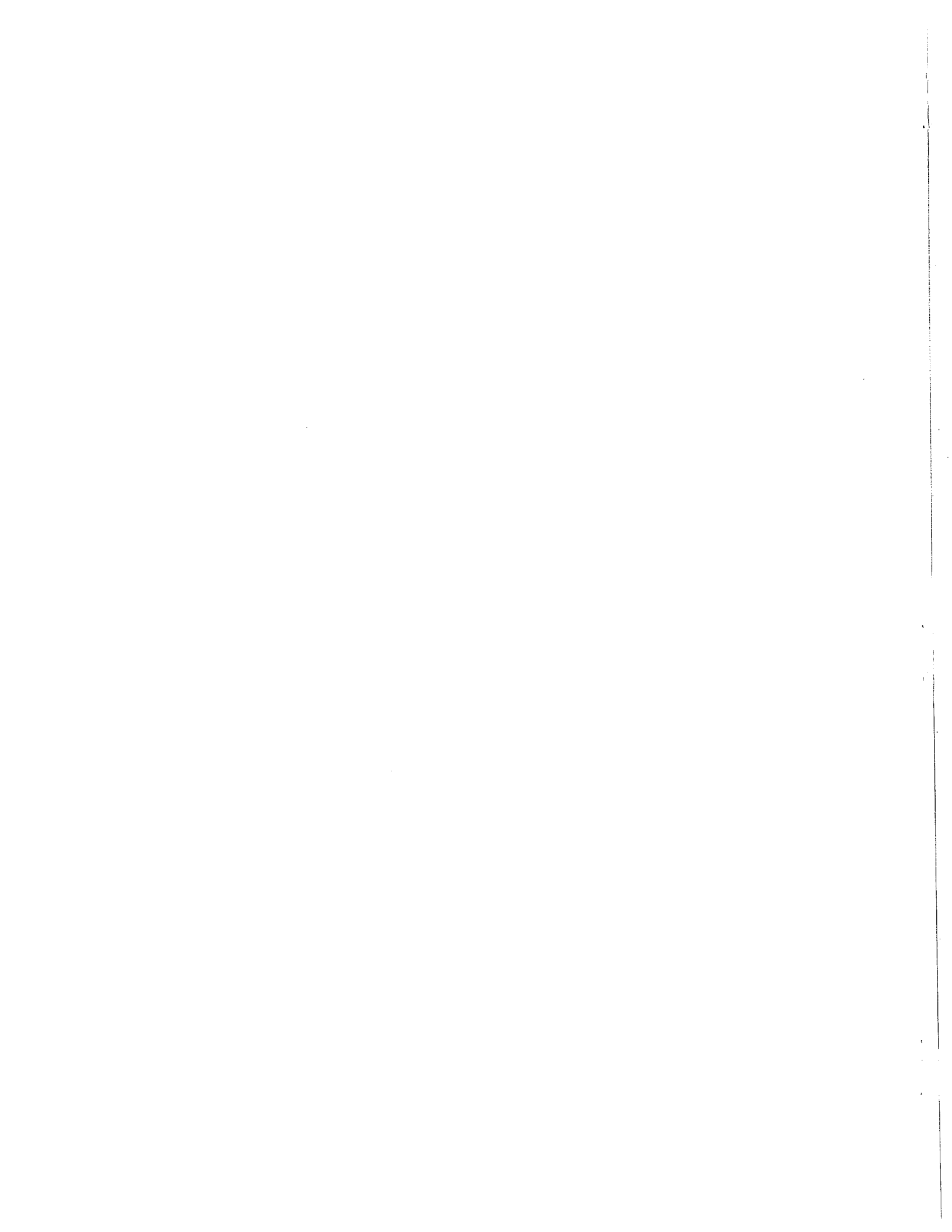

ZONE	TR	DESCRIPTION	DATE	APPROVED
-	B/C	SEE ECO'S #574	2 60G	4-9-87
-	DEF	SEE ECO'S #703, 719, 738	11-2-87	
-	G4	SEE ECO'S #788, 814	8-28-88	
-	J	SEE ECO'S #1379, CHANGE	7-7-89	
-	K	UNAPPROPRIATED ECO #1417	4-17-90	

NOTES: UNLESS OTHERWISE SPECIFIED  
 1. RESISTANCE IS IN OHMS, 1/4W.  
 2. CAPACITANCE IS IN UF.  
 3. U2 IS A LM359.  
 4. DASHED LINE (---) SHOWS BREAK BETWEEN BOARD AND CHASSIS MOUNTED COMPONENTS.  
 5. DIODES ARE IN4148.  
 6. \*R20 \*R25 \*R40 \*R41 ARE "O"TEMP COEFFICIENT TYPE RES.  
 7. MJ10023 IS A DARLINGTON TRANSISTOR.  
 NOTES CONTINUED BELOW.

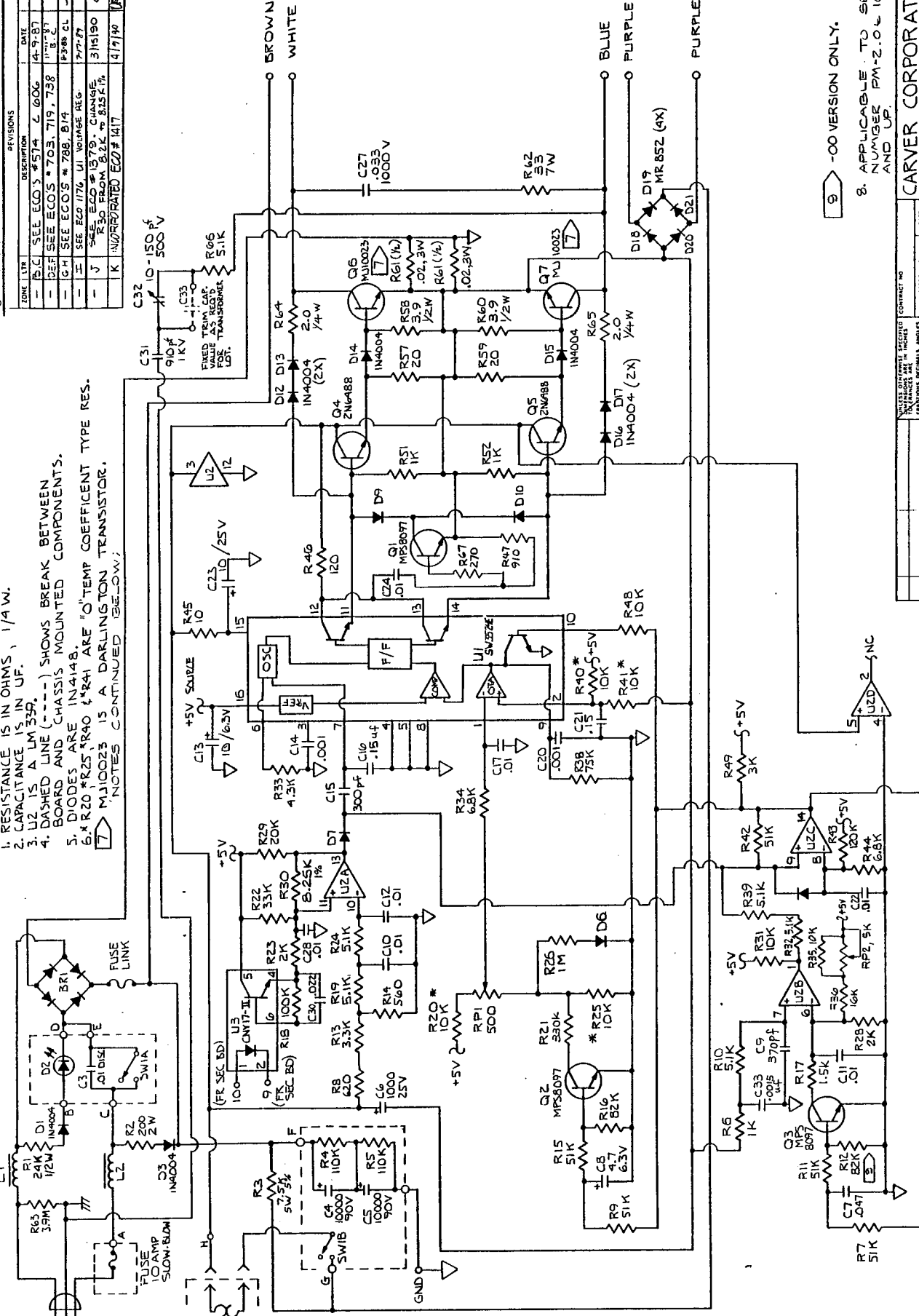

APPROVALS		DATE	CONTRACT NO.
DESIGNED BY	MCQUIRE	3-25-74	
CHECKED			
MULTIPLE COPIES OF THIS DRAWING SHOULD BE MAINTAINED IN THE OFFICE OF THE ORIGINAL ENGINEER AND IN THE OFFICE OF THE CONTRACTOR.			
DATE OF THIS DRAWING			
DRAWING NO.			
SCALE			
REVISIONS			
NO.	DESCRIPTION	DATE	BY
01	605-00401-01 PT-1250 CB		
02	605-00401-02 PT-1250 T20V		
03	605-00401-03		
DO NOT SCALE DRAWING			
DRAWING NO. 1033-84			
SCALE NONE			
RELEASED BY: TMCQUIRE			
DATE: 10-13-84			
SHEET 1 OF 1			

9 -OO VERSION ONLY.  
 8. APPLICABLE TO SERIAL NUMBER PM-2.0 & 100G AND UP.

-OO ASSY  
 -O1 ASSY

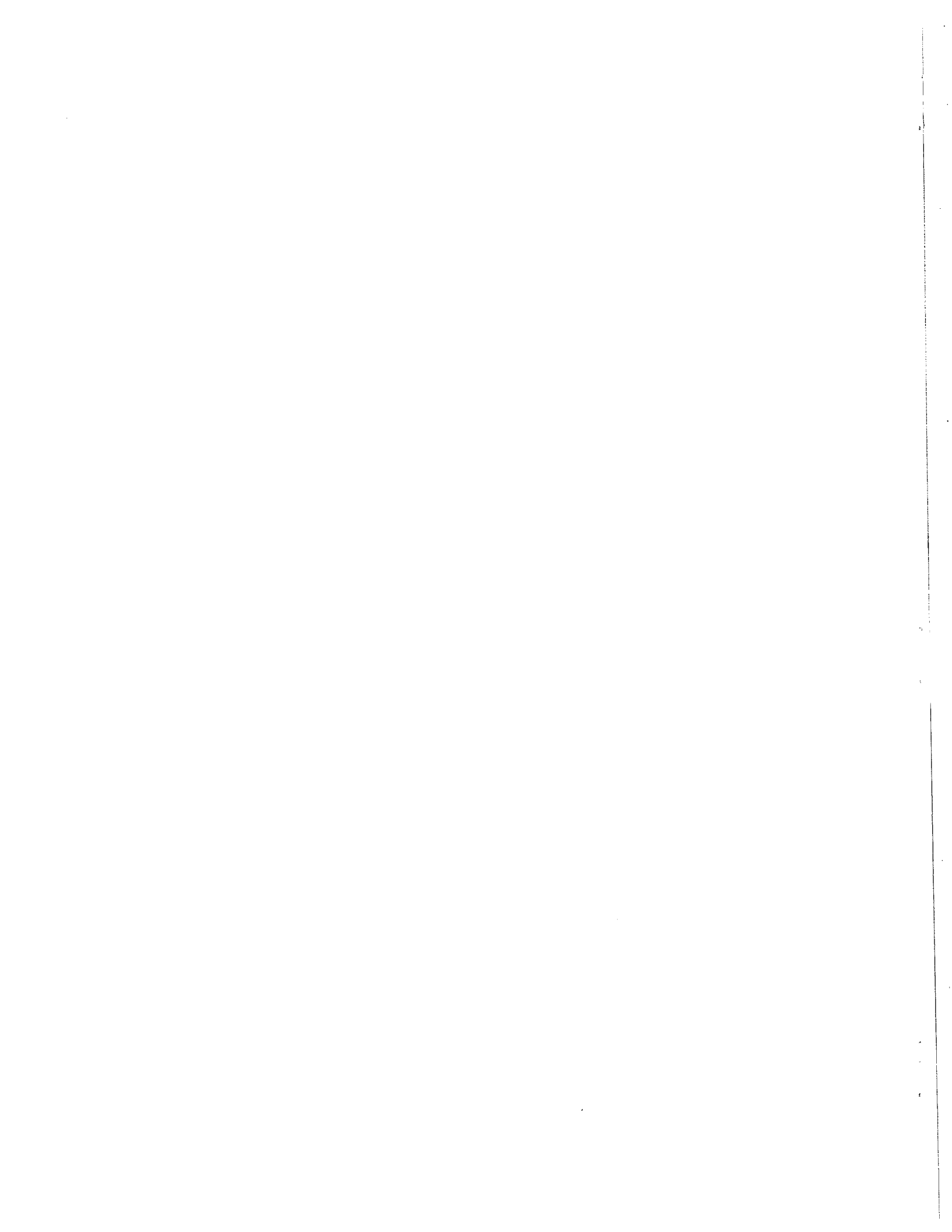



**NOTES: UNLESS OTHERWISE SPECIFIED.**

1. ALL RESISTORS ARE IN OHMS, 1/4 W.
2. ALL CAPACITANCE IS IN UF.
3. DASHED LINE (---) SHOWS BREAK BETWEEN BOARD AND CHASSIS MOUNTED COMPONENTS.
4. DIODES ARE IN4148.
5. LEFT CHANNEL COMPONENTS WITH .100 SERIES NUMBERS HAVE IDENTICAL RIGHT CHANNEL COMPONENTS WITH 300 SERIES NUMBERS.
6. RIGHT CHANNEL INTERFACING AND CIRCUIT DIFFERENCES SHOWN IN RIGHT CHANNEL BLOCK.
7. JUMPERS 1, 2, AND 3 ARE INSTALLED HORIZONTALLY FOR STEREO.
8. DIAGONALLY FOR MONO.

REV	DATE	DESCRIPTION
1	2-10-73	INITIAL
2	2-10-73	REVISED
3	2-10-73	REVISED
4	2-10-73	REVISED
5	2-10-73	REVISED
6	2-10-73	REVISED
7	2-10-73	REVISED
8	2-10-73	REVISED
9	2-10-73	REVISED
10	2-10-73	REVISED

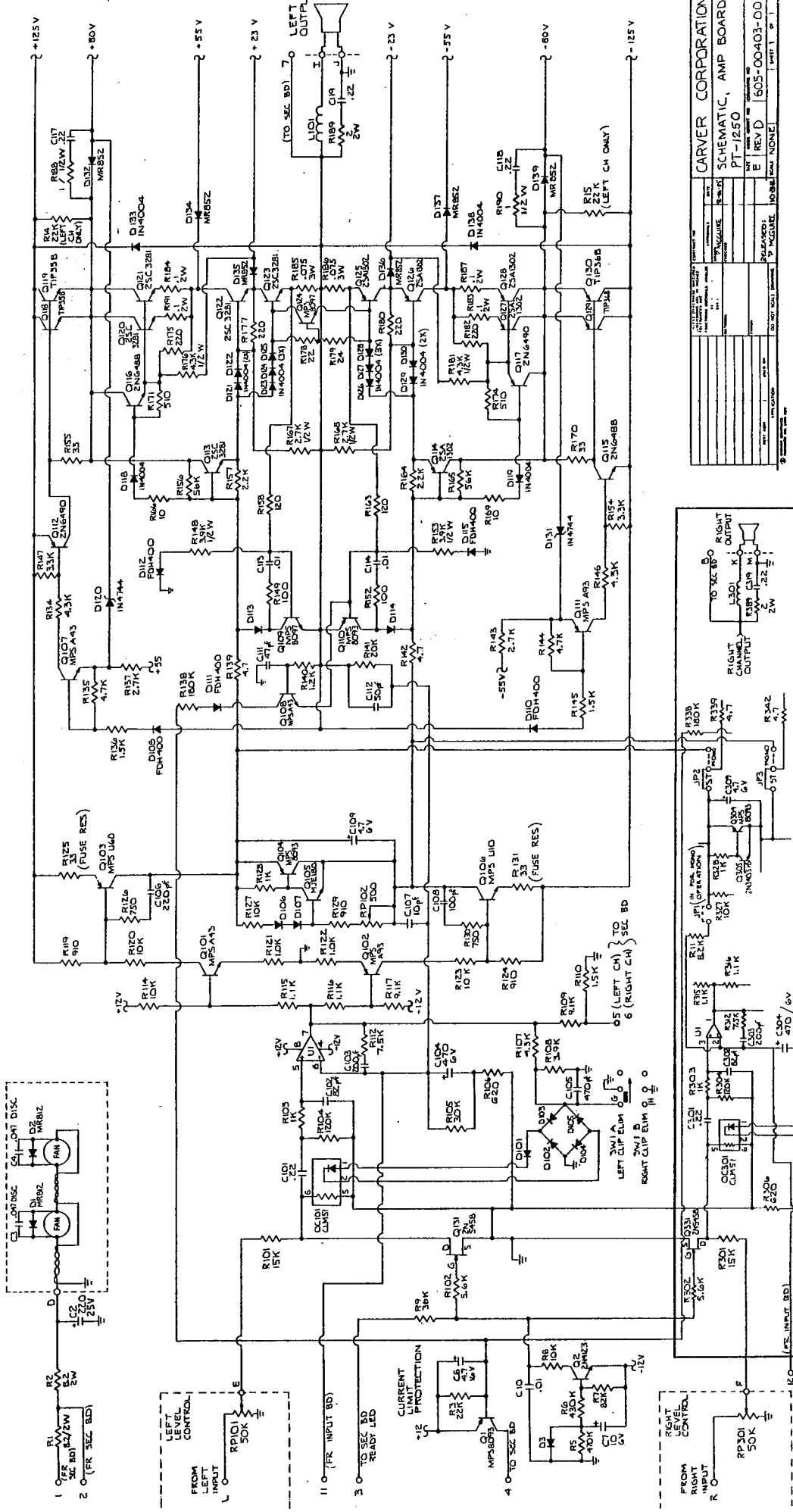
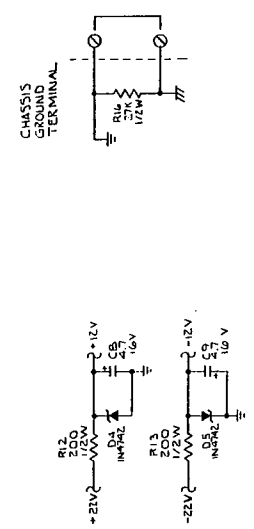

REVISIONS		DATE		DESCRIPTION	
1					
2					
3					
4					
5					
6					
7					
8					
9					
10					

REVISIONS		DATE		DESCRIPTION	
1					
2					
3					
4					
5					
6					
7					
8					
9					
10					

REVISIONS		DATE		DESCRIPTION	
1					
2					
3					
4					
5					
6					
7					
8					
9					
10					

REVISIONS		DATE		DESCRIPTION	
1					
2					
3					
4					
5					
6					
7					
8					
9					
10					

REVISIONS		DATE		DESCRIPTION	
1					
2					
3					
4					
5					
6					
7					
8					
9					
10					

REVISIONS		DATE		DESCRIPTION	
1					
2					
3					
4					
5					
6					
7					
8					
9					
10					

REVISIONS		DATE		DESCRIPTION	
1					
2					
3					
4					
5					
6					
7					
8					
9					
10					

CARVER CORPORATION  
SCHEMATIC, AMP BOARD  
PT-1250  
E REV D 605-00403-00

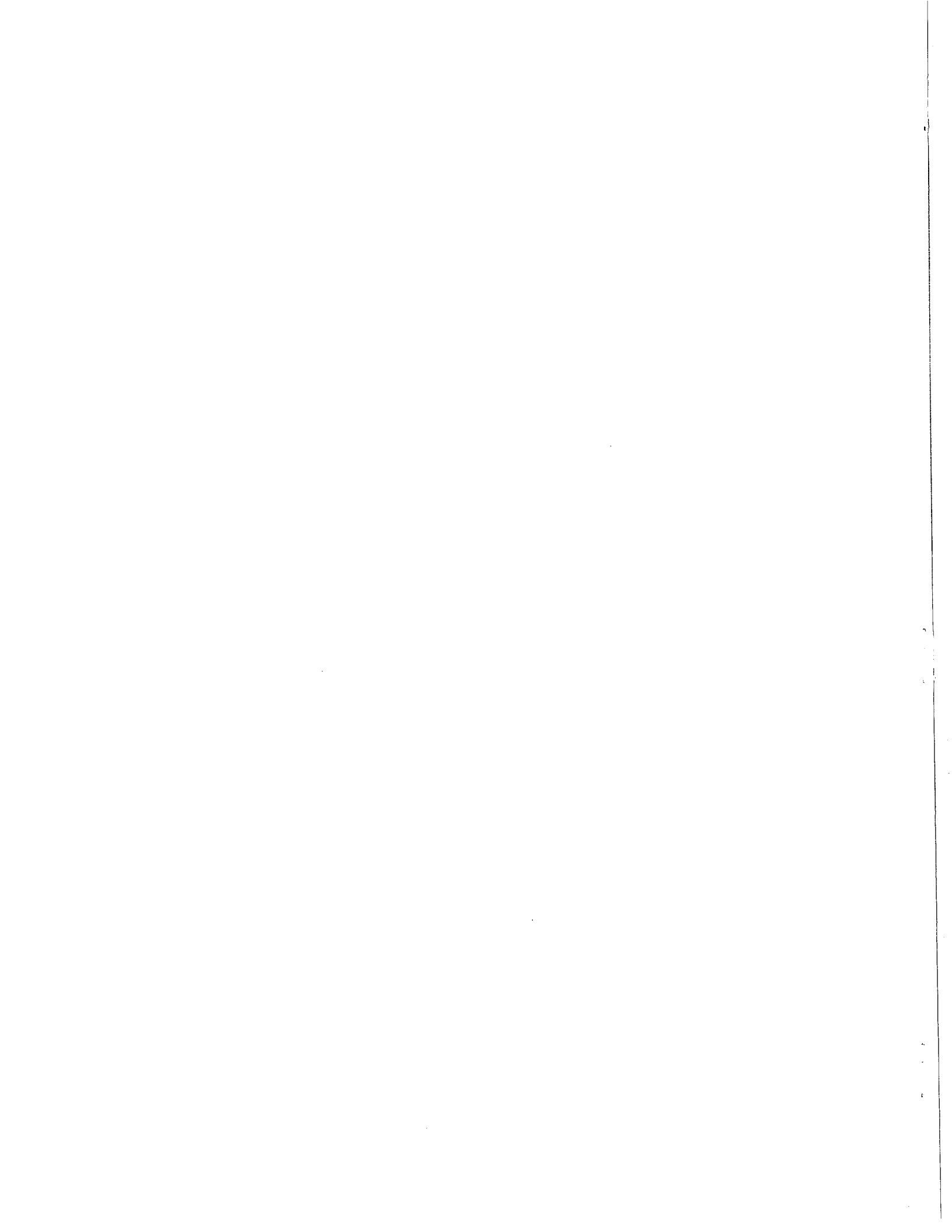



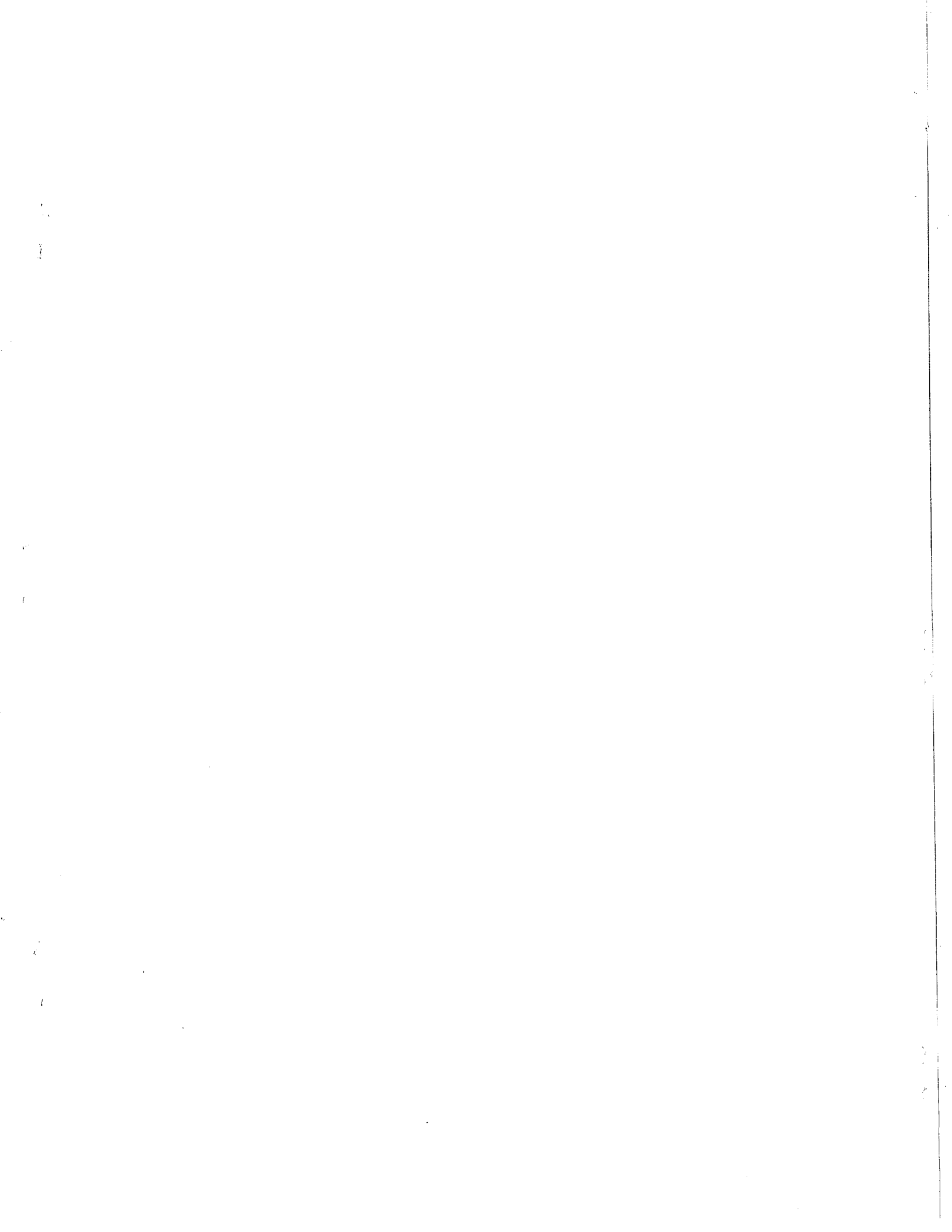

PM 2.0t  
TEST EQUIPMENT REQUIRED

**DISTORTION ANALYZER**

Sound Technology 1100B or equivalent

**OSCILLOSCOPE**

10 MHz dual trace

**VOLT/OHMETER** Fluke 8010/8012 or equivalent

**LOW VOLTAGE POWER SUPPLY**

Variable from 0 to 35 Volts out at 500 mA

**AUTOTRANSFORMER**

25 Amp 0 to 140 Volts output

**LINE ISOLATION TRANSFORMER**

1500 VA rating minimum

**LOAD RESISTORS**

Non inductive  $4\Omega$  and  $8\Omega$  at 500 watts minimum

**AC LINE MONITOR**

True RMS type meter

When making power measurements, the AC line voltage must be maintained at 120 Vac with the Variac. If there is a significant amount of resistance in the wiring to the bench outlet, it may not be possible to obtain the rated power specifications.

Under conditions of actual usage, this is not a problem since the average power consumption is far less than that required for steady state bench testing.

NOTE: The equipment listed above represents minimum requirements for a test bench.

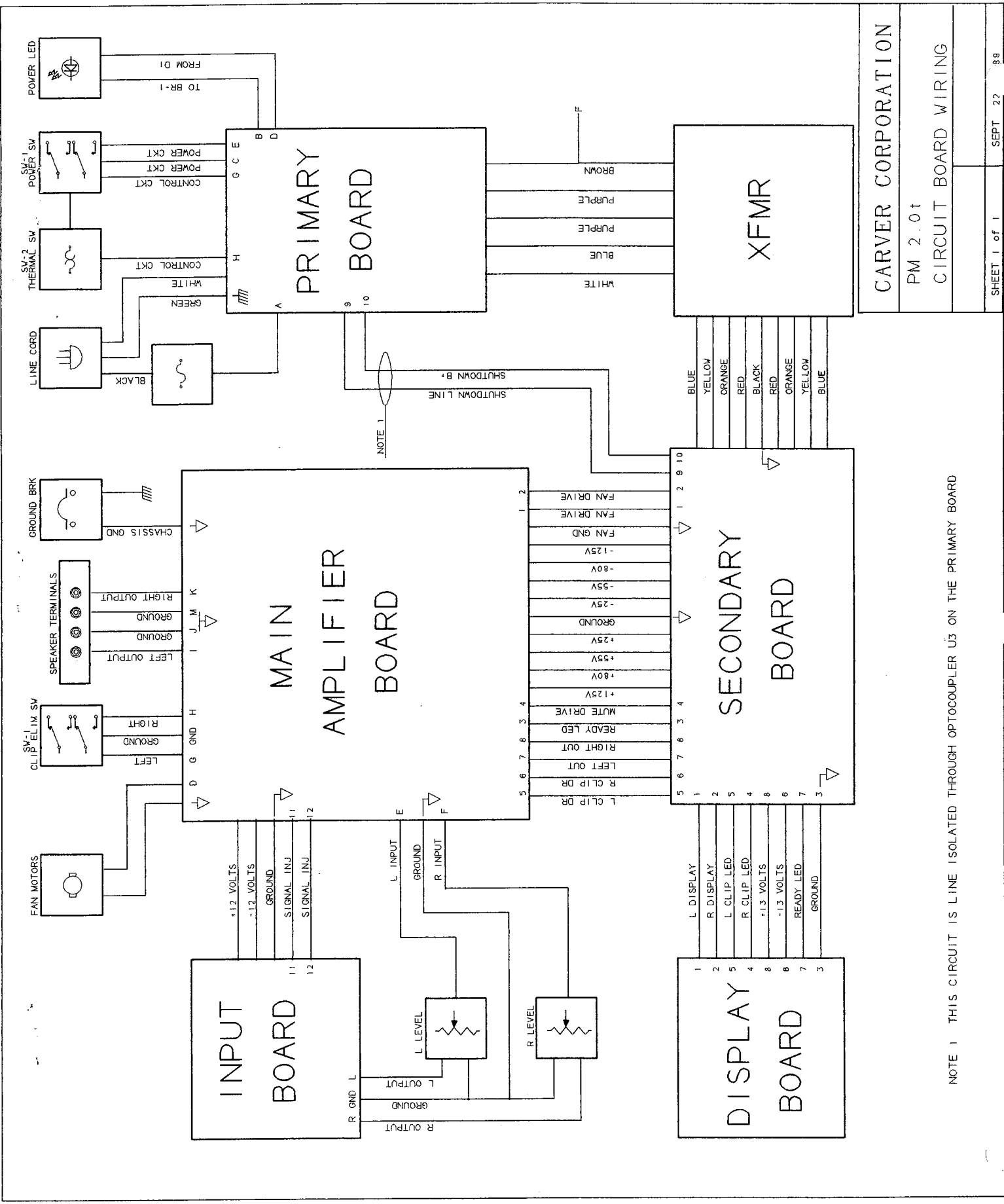

NOTE 1 THIS CIRCUIT IS LINE ISOLATED THROUGH OPTOCOUPLER U3 ON THE PRIMARY BOARD

CARVER CORPORATION  
 PM 2.0t  
 CIRCUIT BOARD WIRING

SHEET 1 of 1      SEPT 22 '89

HEAVY LINE  
INDICATES  
PRIMARY CURRENT  
PATH

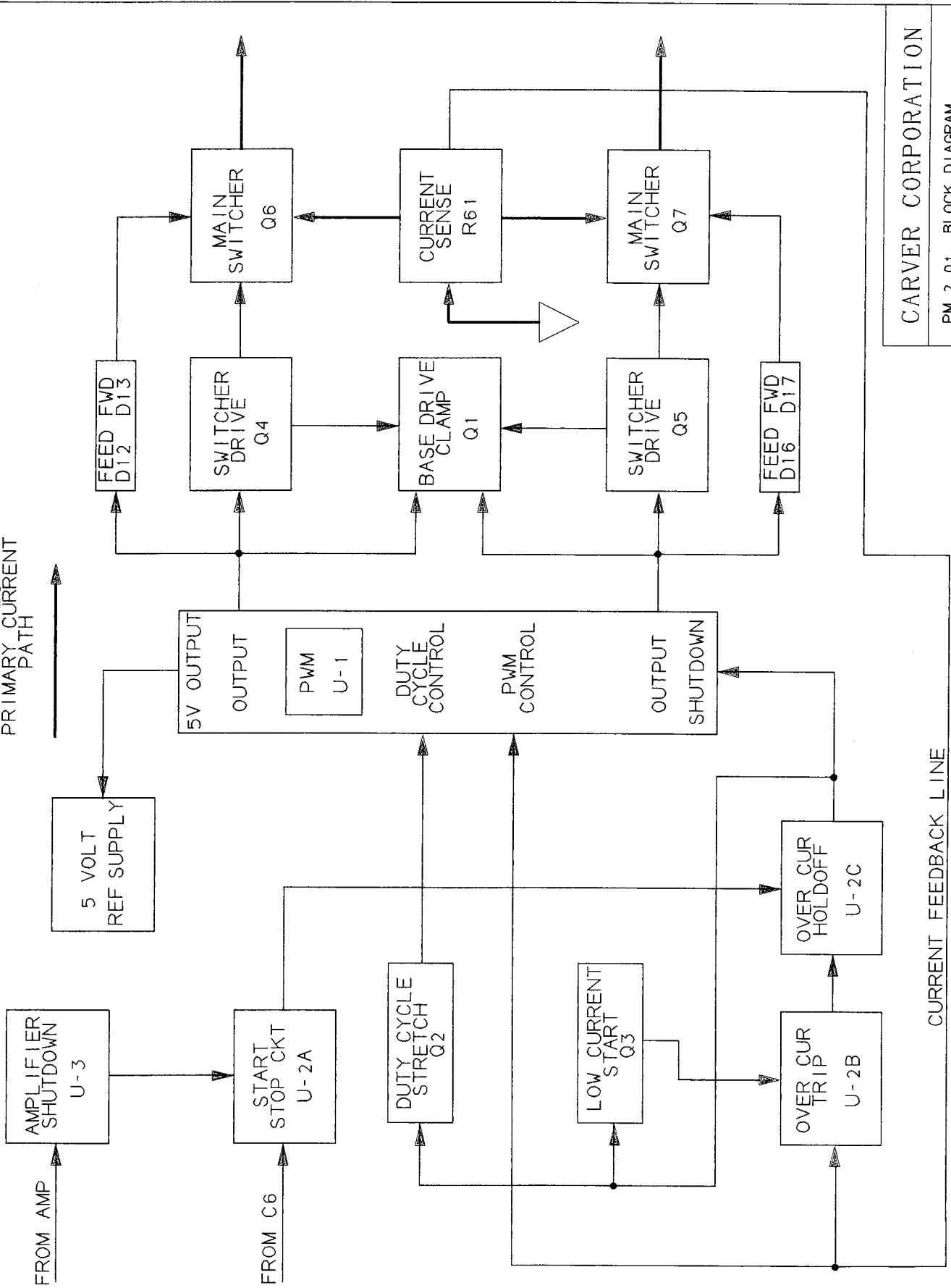

CARVER CORPORATION

PM 2.01 BLOCK DIAGRAM  
POWER SUPPLY PRIMARY BOARD

SHEET 1 of 1

SEPT 24 1989

NOTES: UNLESS OTHERWISE SPECIFIED

- 1 RESISTANCE IS IN OHMS
- 2 CAPACITANCE IS IN UF
- 3 DASHED LINE INDICATES CHASSIS MTD PARTS
- 4 DIODES ARE IN4148
- 5 R20,R25,R40 & R41 ARE .0° TEMP COEFFICIENT

TRANSFORMER  
WIRE COLORS

BROWN  
Voc

WHITE  
PRI 1

BLUE  
PRI 2

PURPLE  
Vfb

PURPLE  
Vfb

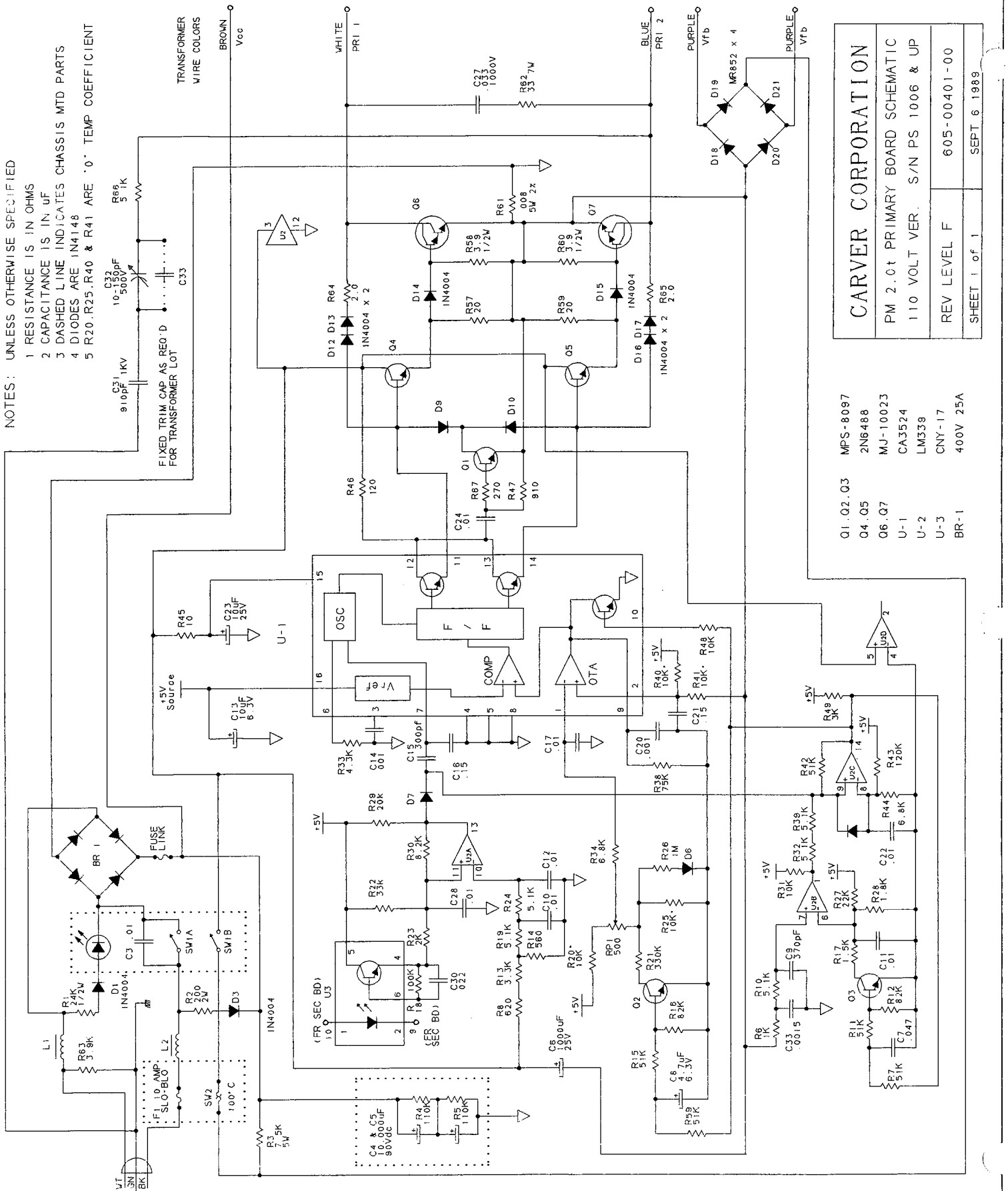

<b>CARVER CORPORATION</b>	
PM 2.0t PRIMARY BOARD SCHEMATIC	
110 VOLT VER. S/N PS 1006 & UP	
REV LEVEL F	605-00401-00
SHEET 1 of 1	SEPT 6 1989

Q1-Q2-Q3	MPS-8097
Q4-Q5	2N8488
Q6-Q7	MJ-10023
U-1	CA3524
U-2	LM338
U-3	CNY-17
BR-1	400V 25A



NOTES: UNLESS OTHERWISE SPECIFIED

- 1 RESISTANCE IS IN OHMS
- 2 CAPACITANCE IS IN uF
- 3 DASHED LINE INDICATES CHASSIS MTD PARTS
- 4 DIODES ARE 1N4148
- 5 R20, R25, R40 & R41 ARE 0° TEMP COEFFICIENT

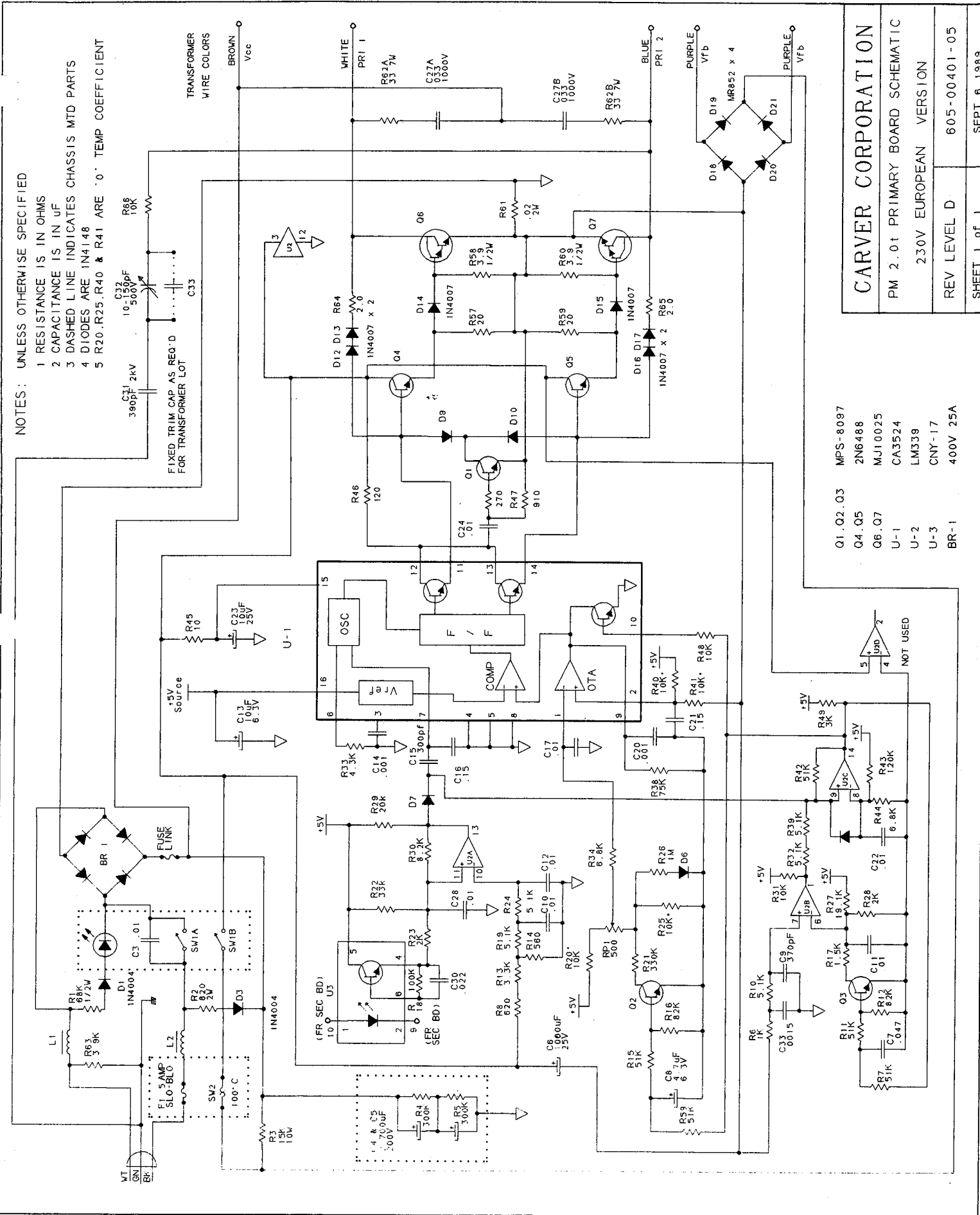

TRANSFORMER  
WIRE COLORS

FIXED TRIM CAP AS REQ'D  
FOR TRANSFORMER LOT

- Q1 .02, Q3 MPS-8097
- Q4, Q5 2N6488
- Q6, Q7 MJ10025
- U-1 CA3524
- U-2 LM339
- U-3 CNY-17
- BR-1 400V 25A

<b>CARVER CORPORATION</b>	
PM 2.0t PRIMARY BOARD SCHEMATIC	
230V EUROPEAN VERSION	
REV LEVEL D	605-00401-05
SHEET 1 of 1	SEPT 6 1989

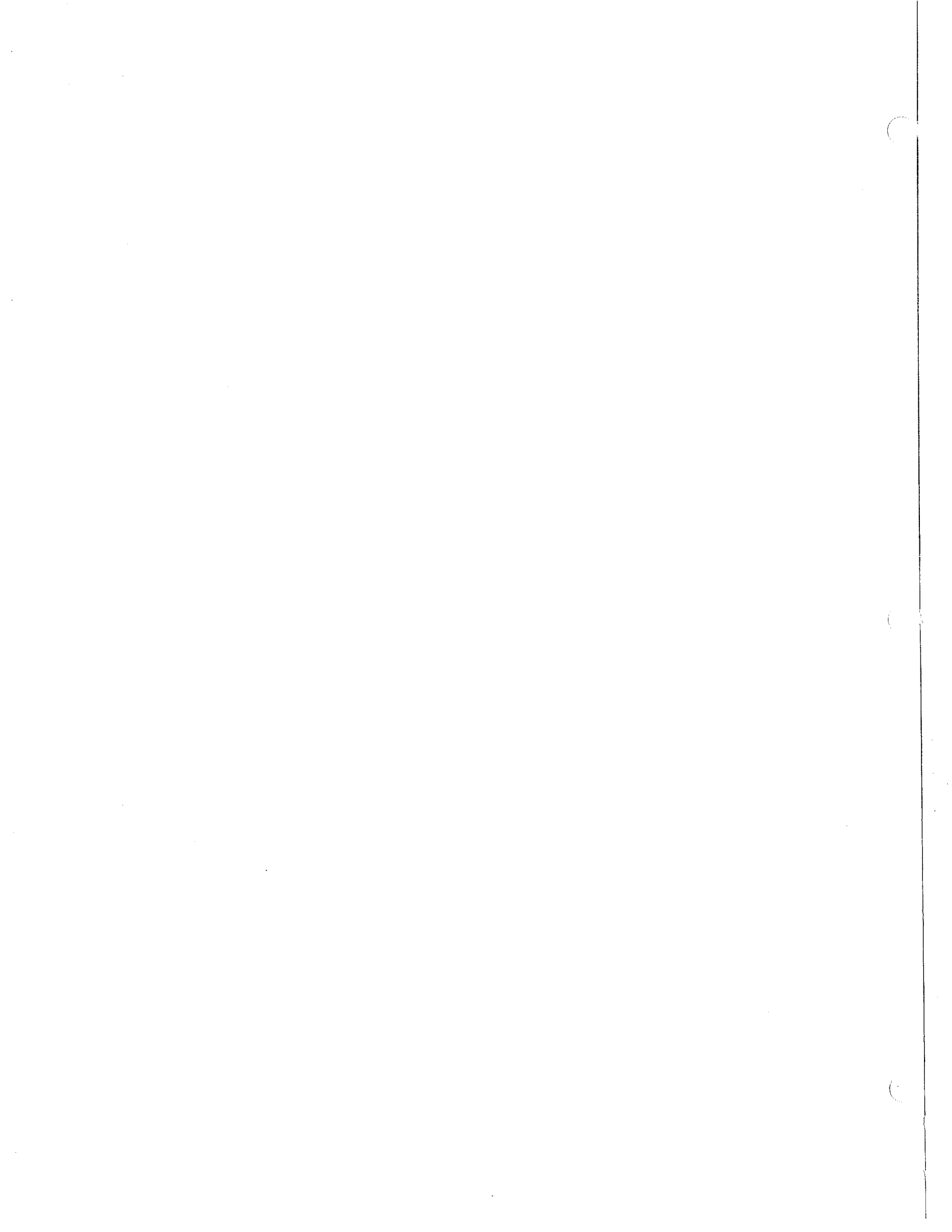

- NOTES: UNLESS OTHERWISE SPECIFIED  
 1. RESISTANCE IS IN OHMS, 1/4W.  
 2. CAPACITANCE IS IN UF.  
 3. U2 IS A LM339.  
 4. DASHED LINE (---) SHOWS BREAK BETWEEN BOARD AND CHASSIS MOUNTED COMPONENTS.  
 5. DIODES ARE 1N4148.  
 6. \*R20, \*R25, \*R40 & \*R41 ARE "O" TEMP COEFFICIENT TYPE RES.  
 7. M10023 IS A DARLINGTON TYPE RES.  
 (NOTES CONTINUED BELOW)

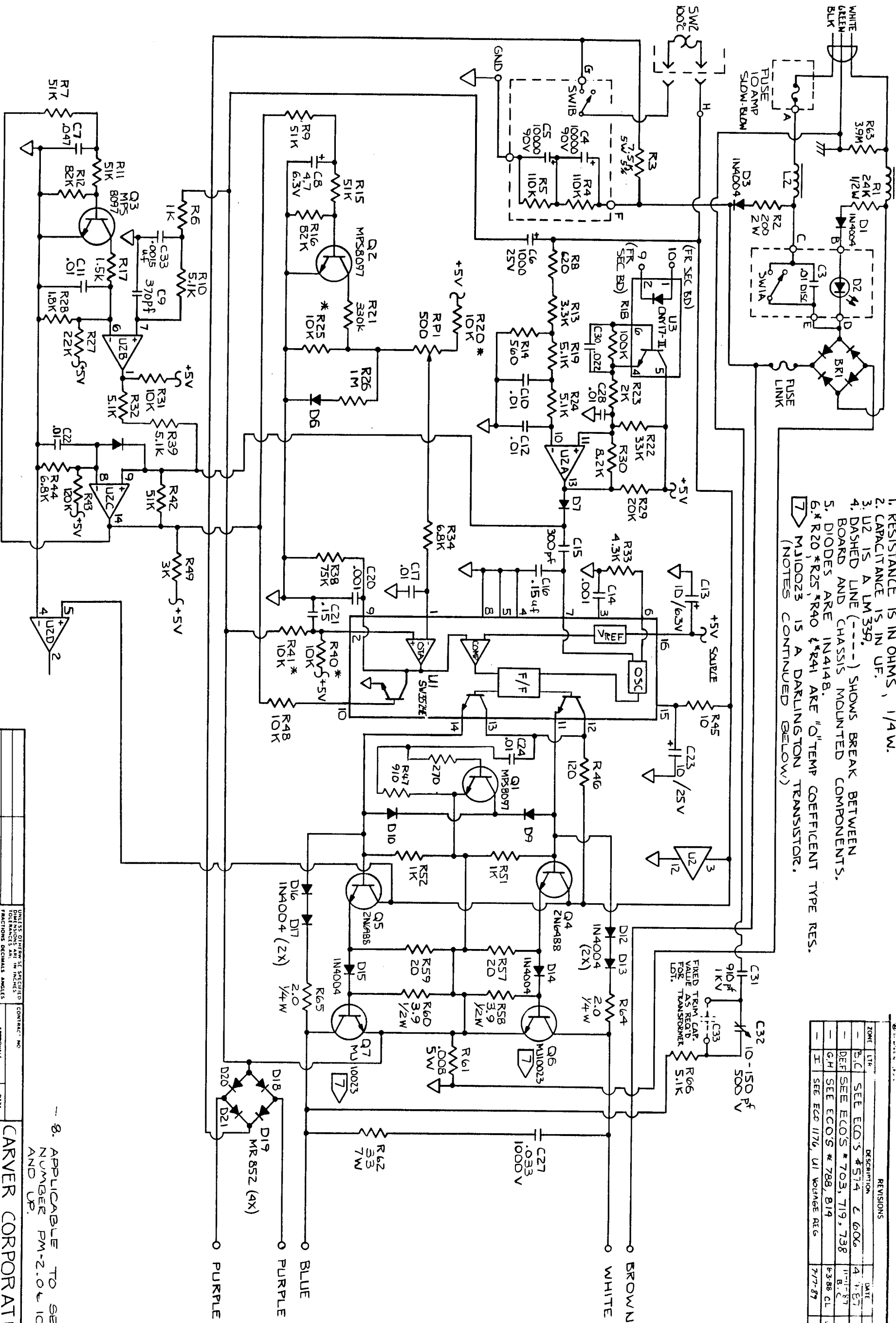

REVISIONS			
ZONE	LT#	DESCRIPTION	DATE
-	B/C	SEE ECO'S #574 & 606	4-1-87
-	DEF	SEE ECO'S #703, 719, 738	11-11-87
-	G/H	SEE ECO'S #788, 814	8-3-88 CL
-	I	SEE ECO 1176, U1 VOLTAGE REG.	7-7-89

8. APPLICABLE TO SERIAL NUMBER PM-2.0 & 1006 AND UP.

CARVER CORPORATION

SCHEMATIC, PRIMARY BOARD, PM-2.0

UNLESS OTHERWISE SPECIFIED CONTRACT NO.	APPROVALS	DATE
DIMENSIONS ARE IN INCHES	DRAWN BY MCGUIRE	3-25-84
FUNCTIONS ARE	CHECKED	
TERMINALS ANGLES		
SEE :		
MATERIAL		
FINISH		
DO NOT SCALE DRAWING	RELEASED BY PMCGUIRE	10-28-84
SCALE NONE	DRAWING NO	605-00401-00
	SIZE	C REV I
		SHEET 1 OF 1



- NOTES: UNLESS OTHERWISE SPECIFIED  
 1. RESISTANCE IS IN OHMS, 1/4W.  
 2. CAPACITANCE IS IN UF.  
 3. U2 IS A LM339.  
 4. DASHED LINE (---) SHOWS BREAK BETWEEN BOARD AND CHASSIS MOUNTED COMPONENTS.  
 5. DIODES ARE 1N4148.  
 6. \*R20, \*R25, \*R40 & \*R41 ARE "O" TEMP COEFFICIENT TYPE RES.  
 7. M110025 IS A DARLINGTON TRANSISTOR.  
 (NOTES CONTINUED BELOW)

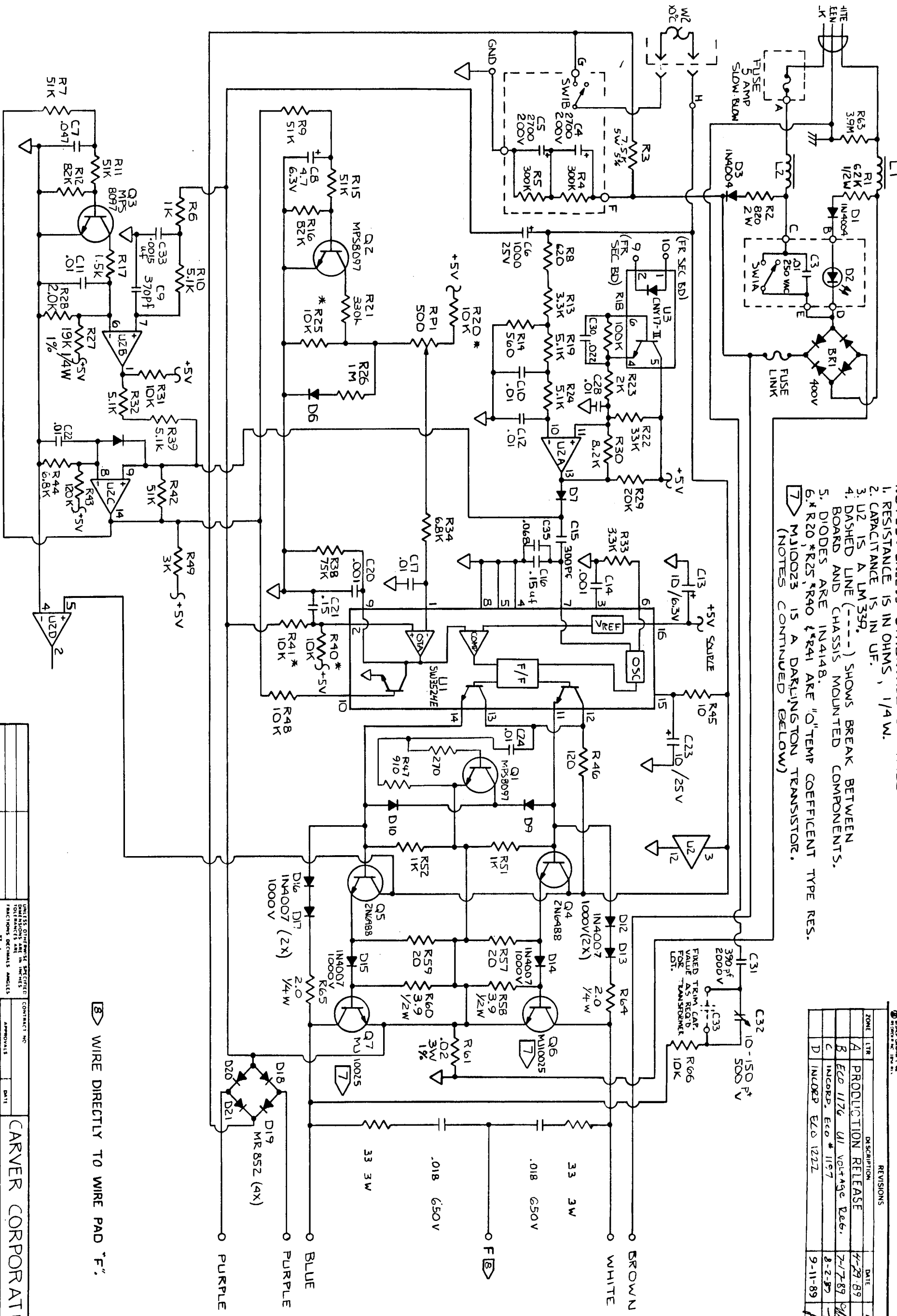

WIRE DIRECTLY TO WIRE PAD "F".

REVISIONS			
ZONE	DESCRIPTION	DATE	APPROVED
A	PRODUCTION RELEASE	4-29-89	
B	Eco 1176 U1 voltage Reg.	7-17-89	
C	INCORP. Eco # 1197	8-2-89	
D	INCORP. Eco 1222	9-11-89	

UNLESS OTHERWISE SPECIFIED DIMENSIONS ARE IN INCHES FRACTIONS DECIMALS ANGLES		CONTRACT NO.	
DATE	APPROVALS	DATE	APPROVALS
3-25-89	PMCGUIRE		
DRAWN BY: PMCGUIRE		CHECKED:	
MATERIAL:		RELEASED:	
FINISH:		025-84	
NEXT ASSY:		SCALE: NONE	
APPLICATION:		SHEET 1 OF 1	
DO NOT SCALE DRAWING:		DRAWING NO. 605-00401-05	
CIRCUIT GRAPHICS:		SHEET 1 OF 1	

CARVER CORPORATION  
 SCHEMATIC, PRIMARY BOARD, PM-2.04 EUR.



- NOTES: UNLESS OTHERWISE SPECIFIED.
1. INSTALL TUBULAR TERMINALS IN WIRE POINTS H, PURPLE, PURPLE AND BOTH SIDES FOR C33.
  2. USE THERMAL COMPOUND ON BOTH SIDES OF MICA INSULATOR.
  3. OUTER HEATSHRINK TUBING MUST COVER 1/2 OF THE LED.
  4. SOLDER LUGS MUST BE POSITIONED AS SHOWN.
  5. SPACERS FITS INSIDE SWITCHER HEATSINK.
  6. BOTTOM OF BOARD MUST BE FREE OF SOLDER FROM EDGE TO .25" IN.
  7. TYRAP TOGETHER 2 LED WIRES, 2 GRAY WIRES FROM L & M AND 2 BLACK WIRES FROM C & E.
  8. INSTALL SLEEVINGS ON R3, R59, R60 & R62. SEE DETAIL 1.
  9. CLAIR BROS UNIT: (602-00401-01)
    - A. BEND LED LEADS AS SHOWN IN DETAIL 2.
    - B. REPLACE WIRE 401-10572-00 WITH 401-10633-00.
    - C. REPLACE WIRE 401-10624-00 WITH 401-10632-00.
    - D. REPLACE WIRE 401-10601-00 WITH 401-10104-00.
    - E. REPLACE WIRE 401-10626-00 WITH 401-10633-00.
  10. REPLACE WIRE 401-10173-00 WITH 401-10109-00.
  11. REPLACE WIRE 401-10143-00 WITH 401-10176-00.
  12. INSTALL 16 PIN DIP SOCKET UNDER U1.
  13. COMPONENTS MUST NOT EXCEED 1/2 IN HEIGHT ABOVE BOARD (EXCEPT BR1).
  14. BEND R61 LEADS OVER THE SOLDER PAD FOR MAX. CONTACT AREA.
  15. SCREENS ON Q6 & Q7 MUST BE TIGHTENED DOWN TO G.T.D. 8 INCH POUNDS.
  16. POSITIVE SIDE OF BRIDGE MUST BE INSTALLED TO INSTALATION TO RIGI MUST BE FLUSH WITH THE BOARD.

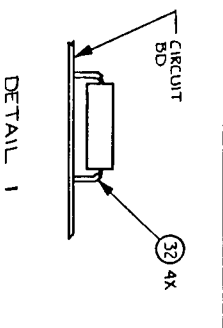

STUFF WIRE LIST

PART NO.	DESCRIPTION	REF DES	QTY
401-1001-00	WIRE 18 AWG TW BUX 2.5"	A	1
401-1052-00	WIRE 18 AWG RED 5.0"	F	1
401-1071-00	WIRE 18 AWG VIO 3.25" GND-J	J	1
401-1068-00	WIRE 18 AWG VIO 4.75" GND-K	K	1
401-1010-00	WIRE 18 AWG VIO 3.0" GND	L	1
401-10625-00	WIRE 22 AWG TMR GREY 4.00"	L	2

REVISIONS

REV	DESCRIPTION	DATE	APPROVED
B	SEE ECO 4 574	10-28-66	P. W. G. W. R.
E	SEE REV BOOK FOR ECO'S INC	4-1-67	T. M. G. W. R.
K	SEE ECOS 703, 738, 748	1-12-67	T. M. G. W. R.
N	LED NO. 755	2-14-67	T. M. G. W. R.
P	SEE ECO 764, 775, 777	2-14-67	T. M. G. W. R.

10. INSTALL 16 PIN DIP SOCKET UNDER U1.
11. COMPONENTS MUST NOT EXCEED 1/2 IN HEIGHT ABOVE BOARD (EXCEPT BR1).
12. BEND R61 LEADS OVER THE SOLDER PAD FOR MAX. CONTACT AREA.
13. SCREENS ON Q6 & Q7 MUST BE TIGHTENED DOWN TO G.T.D. 8 INCH POUNDS.
14. POSITIVE SIDE OF BRIDGE MUST BE INSTALLED TO RIGI MUST BE FLUSH WITH THE BOARD.
15. SCREENS ON Q6 & Q7 MUST BE TIGHTENED DOWN TO G.T.D. 8 INCH POUNDS.
16. POSITIVE SIDE OF BRIDGE MUST BE INSTALLED TO RIGI MUST BE FLUSH WITH THE BOARD.

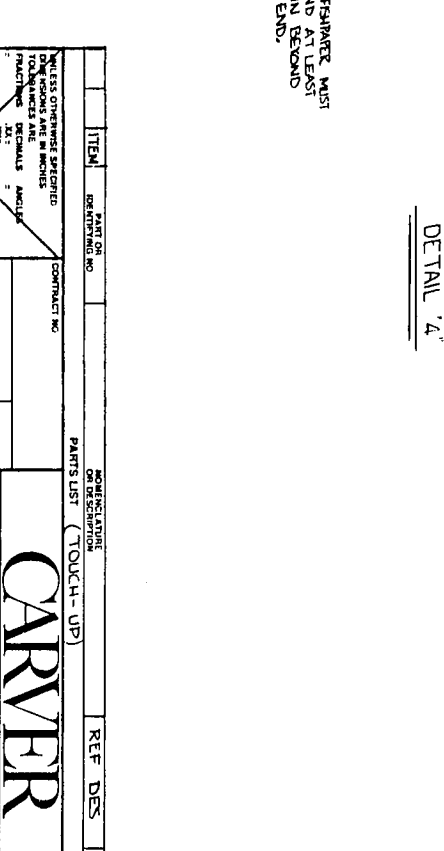
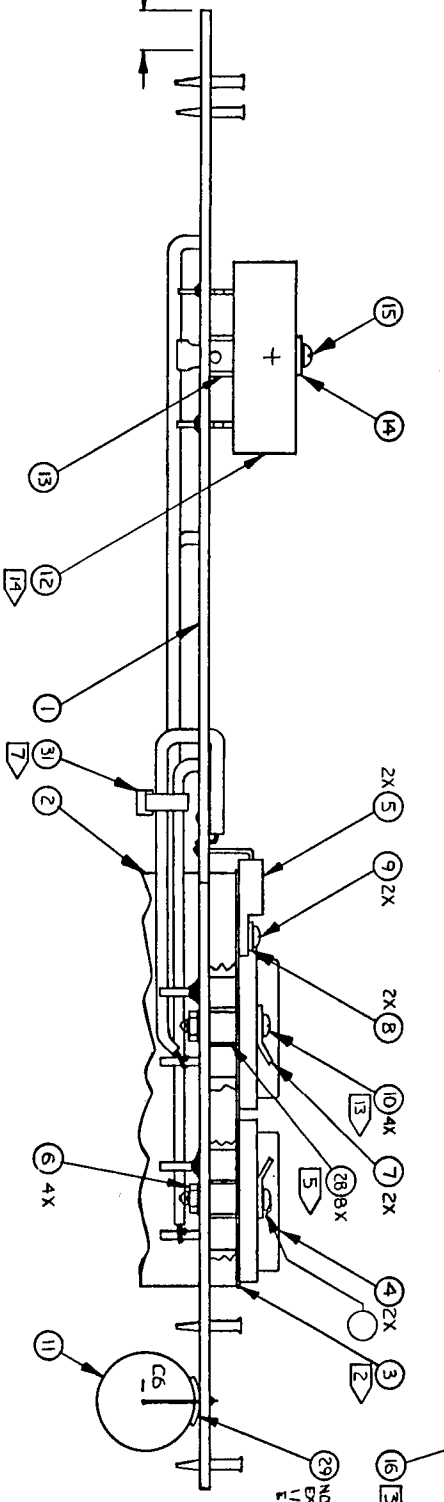
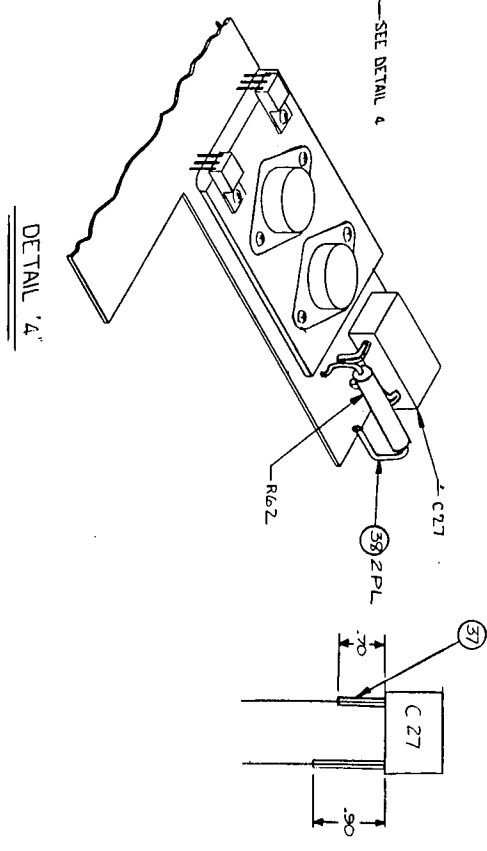
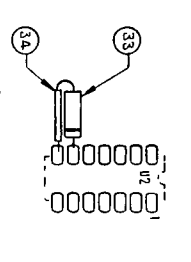
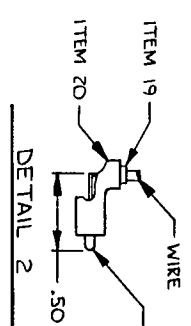
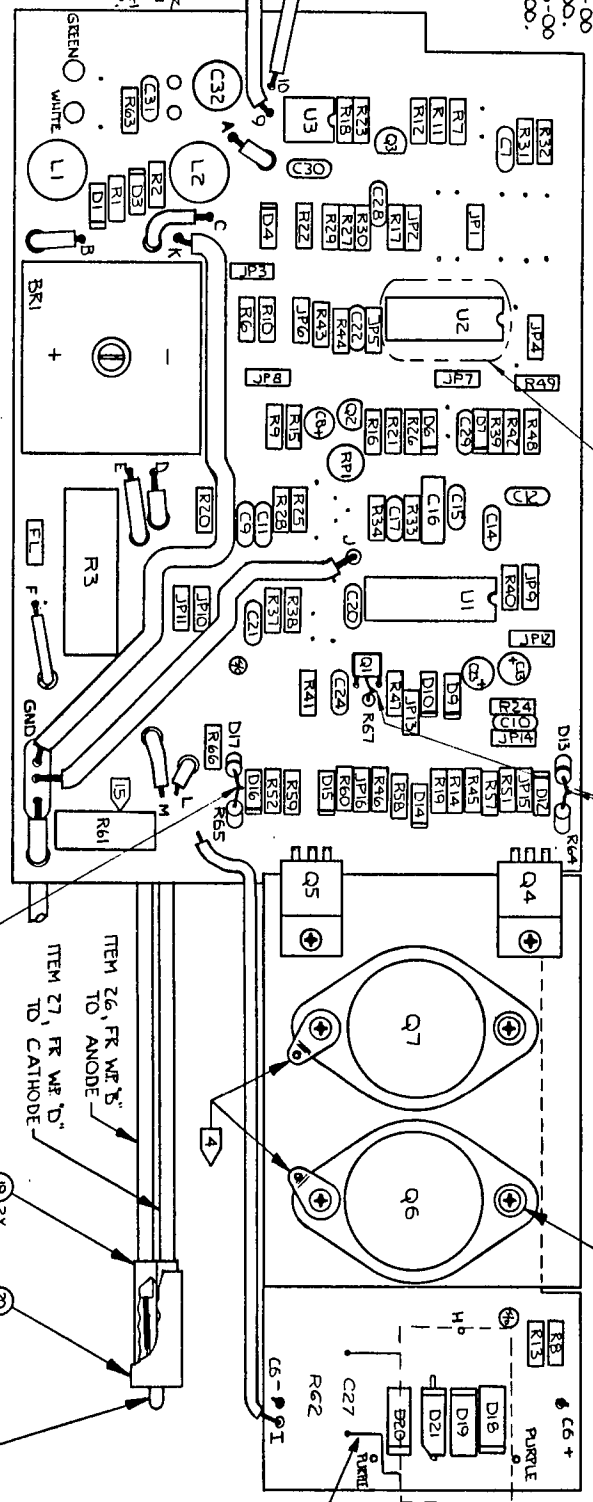

STUFF  
 601-00401-00 EVF  
 601-00401-01 D  
 602-00401-01 F

ITEM	QTY	DESCRIPTION	REF DES	QTY
PARTS LIST (TOUCH-UP)				
TOUCH-UP, PRIMARY BOARD				
DATE: 7/7/66				
DRAWN BY: P. W. G. W. R.				
CHECKED BY: P. W. G. W. R.				
RELEASED BY: P. W. G. W. R.				
DATE: 2/11				
SCALE: 2/1				
SHEET NO: 602-00401-00				
PAGE: 1 OF 1				

**CARRIER**

TOUCH-UP, PRIMARY BOARD





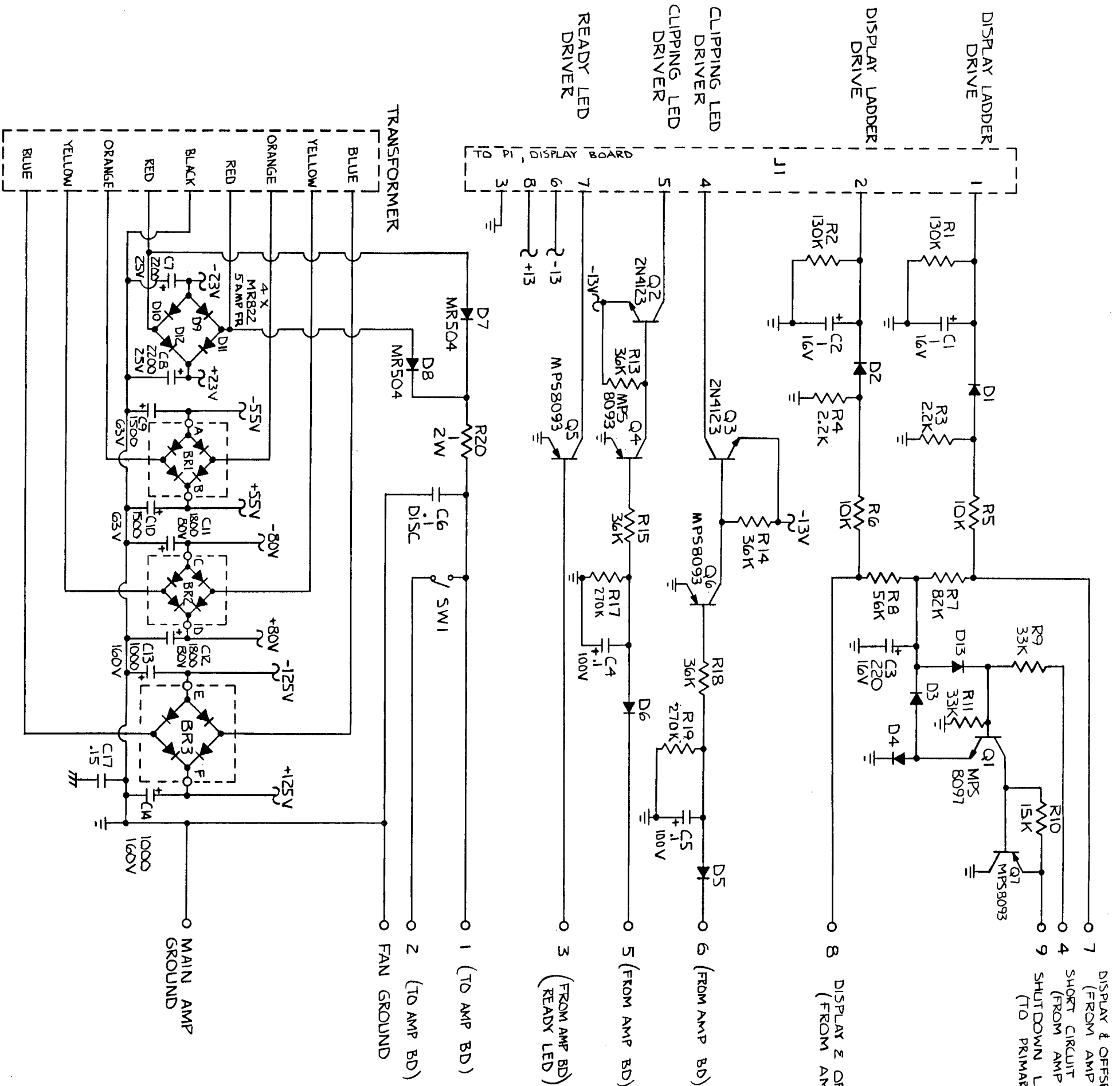

7 (FROM AMP BD)  
 4 (SHORT CIRCUIT SHUTDOWN (FROM AMP BD))  
 9 SHUTDOWN LINE (TO PRIMARY BD, U3)

REVISIONS			
ZONE	LTR	DESCRIPTION	DATE
3	ECO	678	12-2-87
C	INCORP.	ECO # 1045	4-28-89

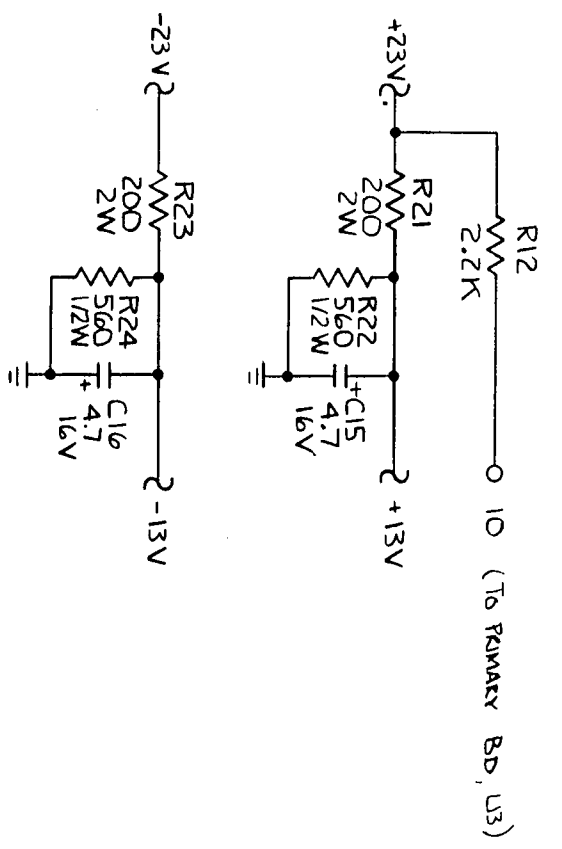

NOTES: UNLESS OTHERWISE SPECIFIED.  
 1. ALL RESISTANCE IN OHMS, 1/4 W.  
 2. CAPACITANCE IS IN MICROFARADS.  
 3. DIODES ARE IN4148.  
 4. DASHED LINE (---) SHOWS BREAK BETWEEN BOARD AND CHASSIS MOUNTED COMPONENTS.

CONTRACT NO		CARVER CORPORATION	
APPROVALS		DATE	
DESIGNED BY	P. MCGUIRE	DATE	11-7-85
CHECKED			
RELEASED BY	P. MCGUIRE	SCALE	NONE
SIZE	C	REV	C
DRAWING NO	605-00402-00	SHEET	1 OF 1

- NOTES: UNLESS OTHERWISE SPECIFIED.
1. INSTALL TUBULAR TERMINALS AT WIRE POINTS +23, +55, +80, +125, -23, -55, -80, -125, 1, 2, 3, 4, 5, 6, 7, 8.
  2. USE THERMAL COMPOUND ON BOTH SIDES OF MICA INSULATORS.
  3. INSTALL .5" SLEEVING ON R125, R131, R325 & R331. SEE DETAIL 1.
  4. SOLDER WIRE INTO BACK OF BOARD.
  5. USE THERMAL COMPOUND BETWEEN TRANSISTORS AND HEATSINK, 4 PL.
  6. MONO BLOCK UNITS: DELETE ITEM 16. INSTALL JUMPER 1-3 DIAGONALLY AS SHOWN IN DETAIL 2.

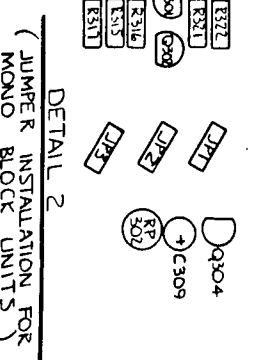
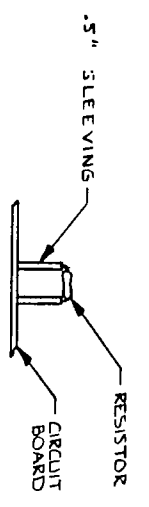
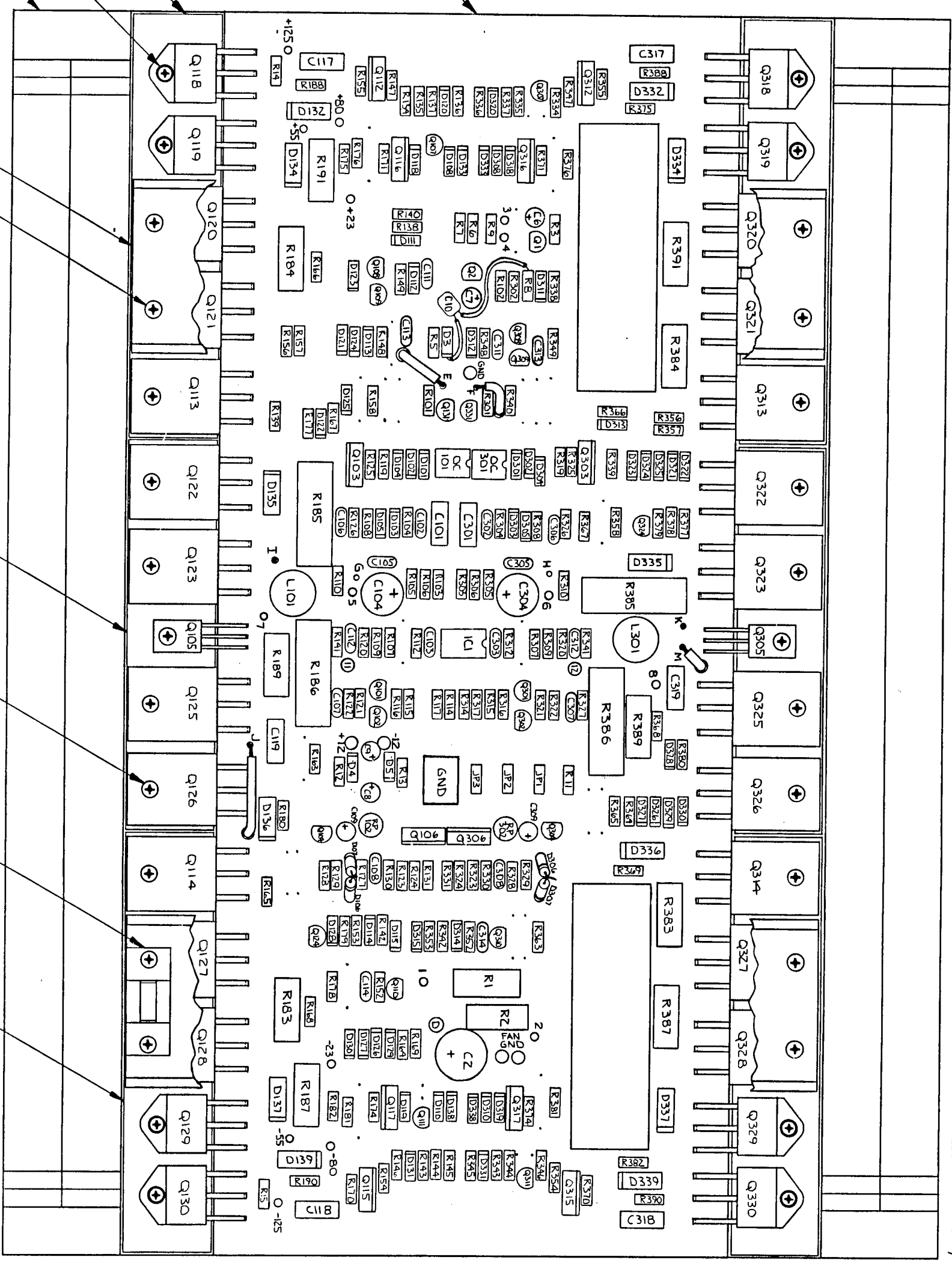

REV	DATE	DESCRIPTION	BY	CHKD
1				
2				
3				
4				
5				

ITEM	REF DES	PART NO.	DESCRIPTION	QTY
PARTS LIST (TOUCH-UP)				
CARVER CORPORATION				
TOUCH-UP AMP BOARD,				
PM-2.04				
REV	DATE	BY	CHKD	APPROVED
D				
REV 2				
602-00403-00				
PAGE 1 OF 1				

STUFF 601-00403-00 REVA

MONO BLOCK, STUFF 601-00403-02

REV	DATE	BY	CHKD	APPROVED
1				
2				
3				
4				
5				



REVISIONS		DATE	APPROVE
ZONE	DESCRIPTION		
1/A			

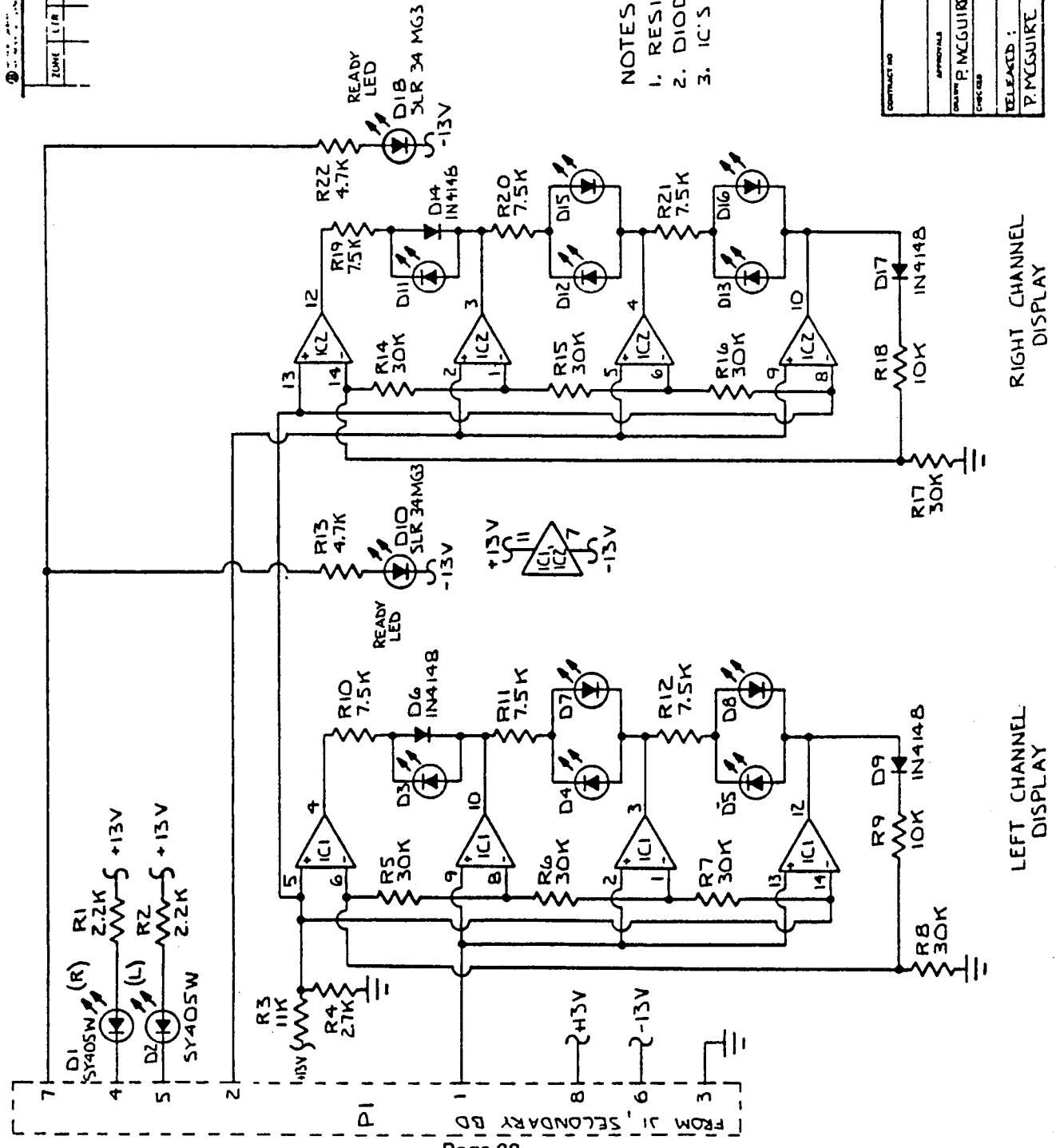

NOTES : UNLESS OTHERWISE SPECIFIED  
 1. RESISTANCE IS IN OHMS , 1/4W.  
 2. DIODES ARE 5R505W.  
 3. IC'S ARE 4136.

CONTRACT NO.		CARVER CORPORATION	
APPROVALS	DATE	SCHEMATIC, DISPLAY BOARD, PM-201	
DESIGNER P. MCGUIRE	12-11-55	SIZE / PFORM NO.	DWG. NO. 605-00405-00
CHECKED :		SCALE	NONE
RELEASED :		BY	P. MCGUIRE
		NO. OF SHEETS	1 OF 1

NOTES: UNLESS OTHERWISE SPECIFIED  
 1. D1 - D5, D7, D8, D10 - D13, D15, D16 & D18 MUST STAND .06" OFF THE BOARD. SEE DETAIL 1.

REVISIONS		
ZONE	DESCRIPTION	DATE
LTR		

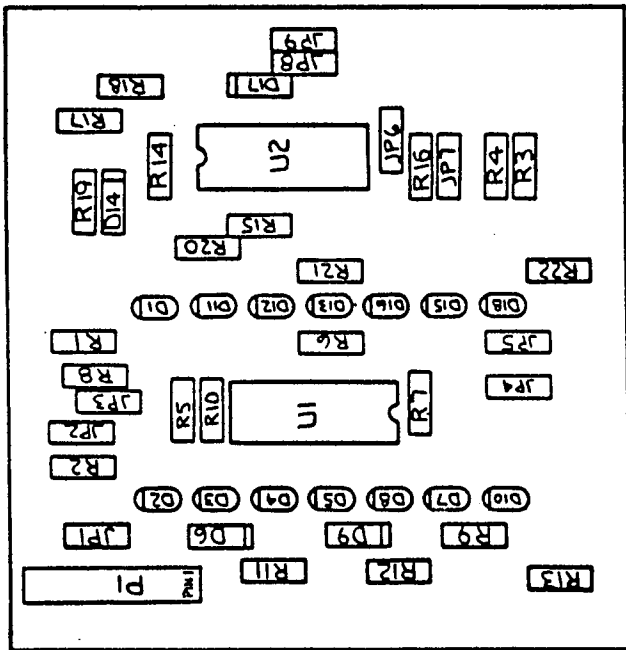

STUFF 601-00405-00 REV A

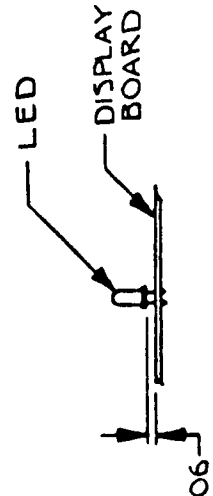

UNLESS OTHERWISE SPECIFIED DIMENSIONS ARE IN INCHES FRACTIONS DECIMALS & GAGES		CONTRACT NO.	CARVER CORPORATION
APPROVALS	DATE	DRAWING NO.	A.I., DISPLAY BOARD, PM-2.0t
DRAWN P MCGUIRE	3/8/76	SIZE	B
CHECKED		DRAWING NO.	602-00405-00
		REV A	602-00405-00
		SCALE	2/1
		RELEASED	10-7-86
		BY	PM.
		DO NOT SCALE DRAWING	
		USED ON	
		APPLICATION	
		NEST ASSY	
		SHEET	1 OF 1

31 SHOP GRAPHICS REORDER NO 109 REV

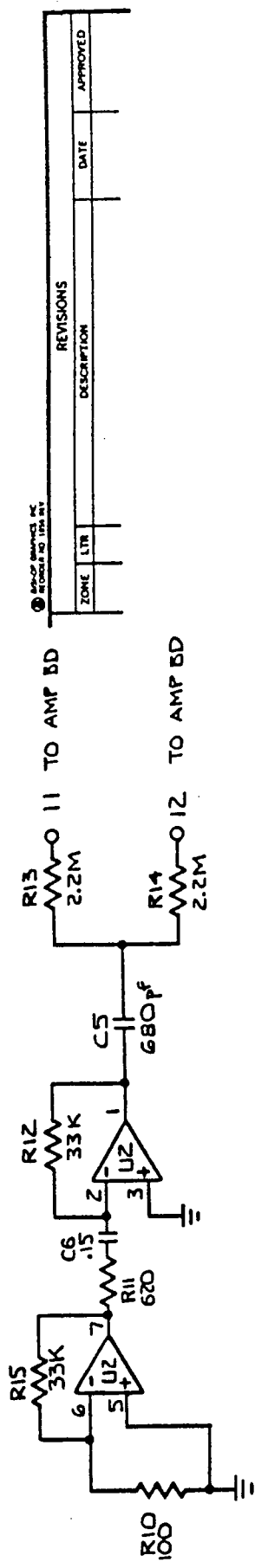

② MAKE REVISIONS IN RECORD NO. 1004 REV.

REVISIONS		DATE	APPROVED
ZONE	DESCRIPTION		
LTR			

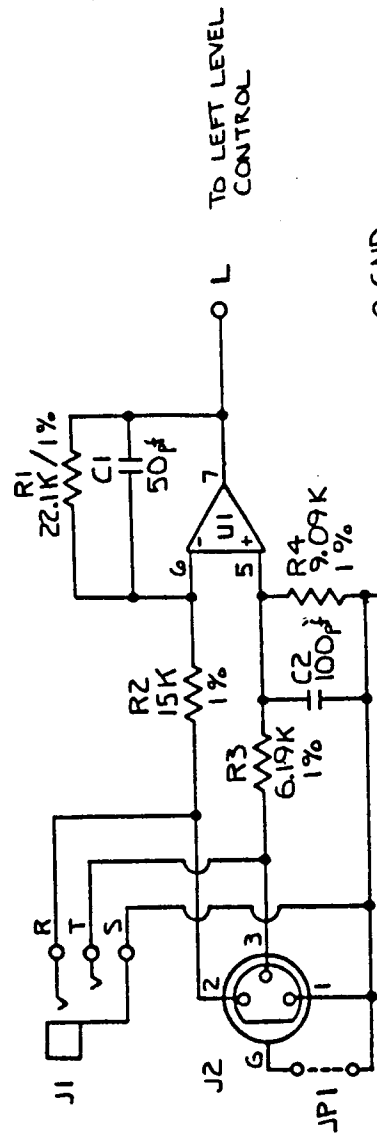

LEFT INPUT

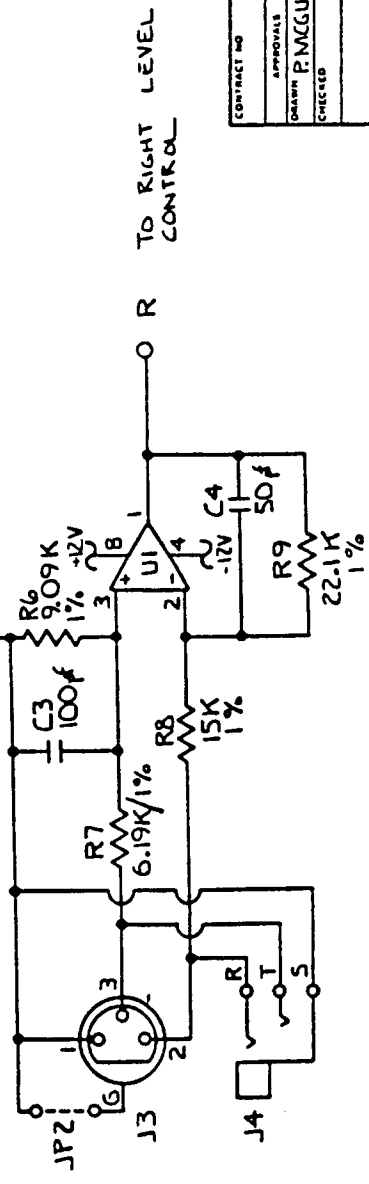

RIGHT INPUT

NOTES: UNLESS OTHERWISE SPECIFIED  
 1. RESISTORS ARE IN OHMS, 1/4W.  
 2. U1 & U2 ARE TLO-72.

CONTRACT NO.	APPROVALS	DATE	DRAWING NO.
	DRAWN P. MCGUIRE 11-9-85		
	CHECKED		SIZE B
			REV A
			SCALE NONE
			SHEET 1 OF 1
RELEASED:		DRAWING NO. 605-00404-00	
P. MCGUIRE 10-28-86		SCHEMATIC, INPUT BOARD, PM-2.0t	
CARVER CORPORATION			



Fig 1

Base drive wave form of clamping transistor Q1.

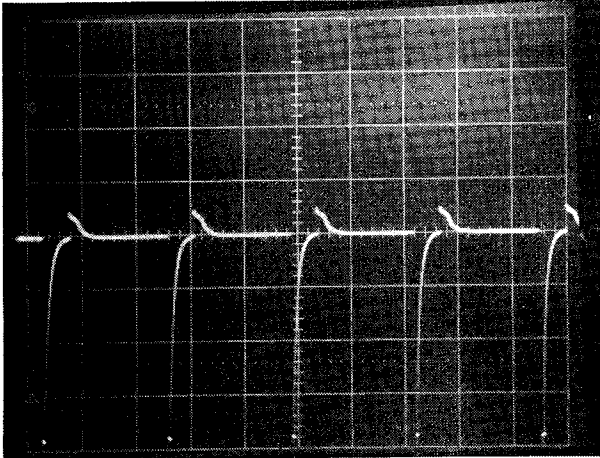

200  $\mu$ Sec / div  
2 Volts / div

Q1 Base drive

Q4 & Q5 base drive

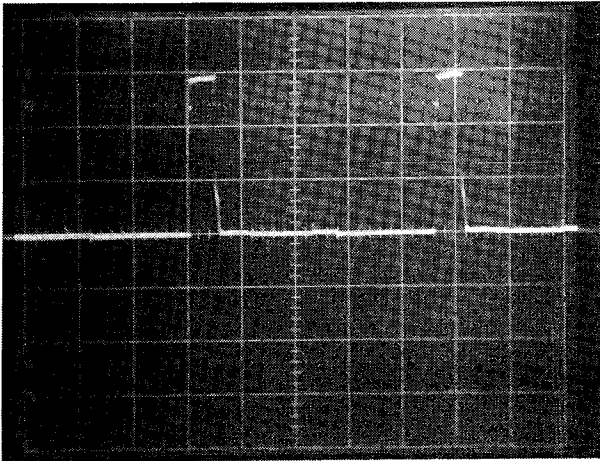

Fig 2

Base drive of Q4 / Q5 at idle.

200  $\mu$ Sec / div  
1 Volt / div

Q1 - Q4/Q5 timing relationship

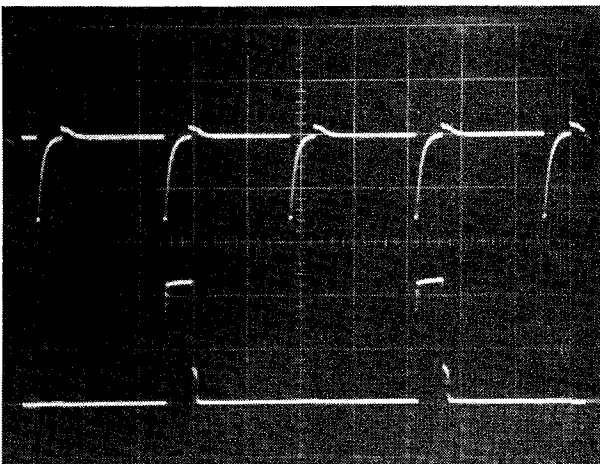

Fig 3

Timing pattern between the base drive of Q4 or Q5 and the clamping drive at the base of Q1.

200  $\mu$ Sec / div



Fig 4

Oscillator ramp output at pin 7 of U-1 (CA3524). This frequency is twice that of the switching transistors. The time period at pin 7 is 480-500  $\mu$ Sec.

100  $\mu$ Sec / div  
1 Volt / div

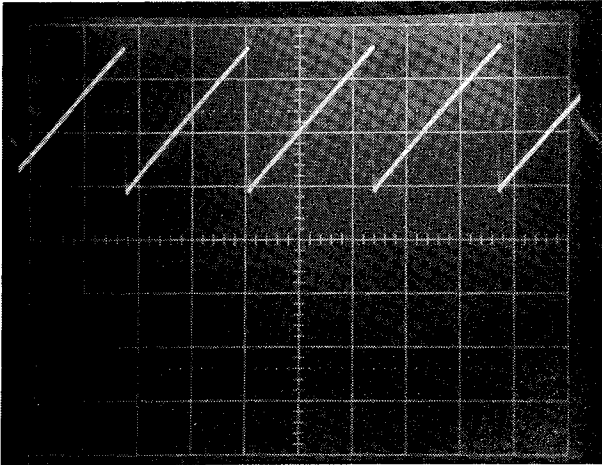

Oscillator ramp

Shut down drive

Fig 5

Output of U2-C pin 14 during start up or continuous over current fault condition. This shut down signal clamps the output of the switching regulator U-1.

200  $\mu$ Sec / div  
2 Volts / div

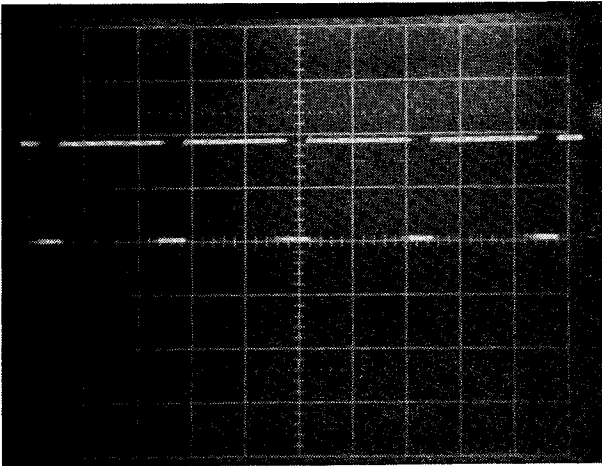

Reset pulses

Fig 6

Wave form at pin 9 of U2-C. These pulses set the output of U2-C low during the over current start up sequence.

200  $\mu$ Sec / div  
1 Volt / div

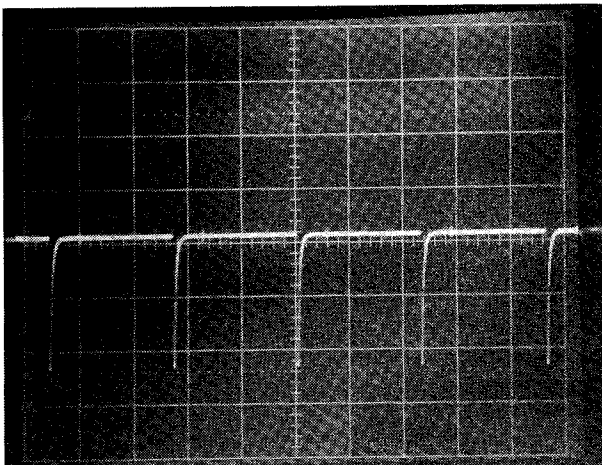

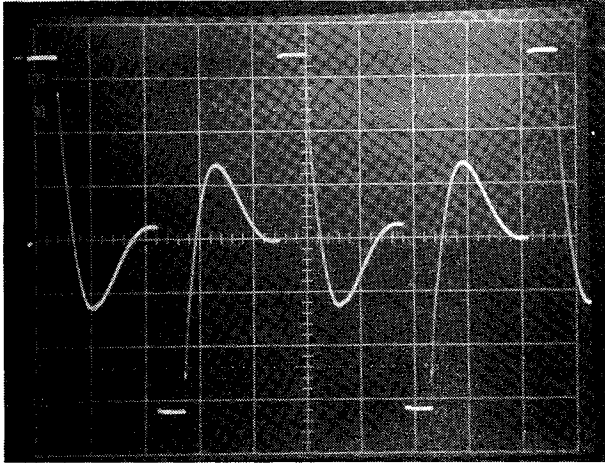

Q6/Q7 Collector wave form

Q6/Q7 Emitter wave form

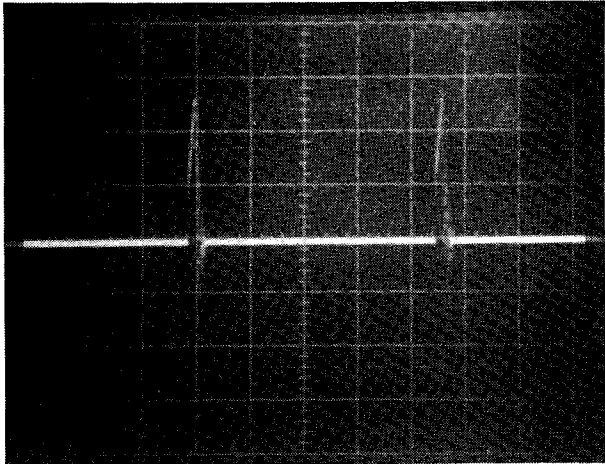

Q6/Q7 Emitter wave form

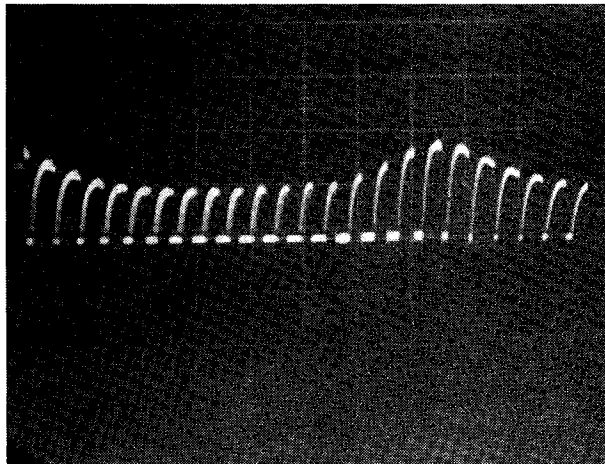

Fig 7

Collector wave form of Q6 / Q7 at idle with the amplifier output at zero. The idle time period should be set to 60-80  $\mu$ Sec.

NOTE: The peak voltage swing at this point is nearly 400 volts. Caution must be used when checking Q6 and Q7!

An isolation transformer must be used when servicing the primary circuitry!!

200  $\mu$ Sec / div

50 volts / div

Fig 8

Q6 & Q7 collector current wave form across R-61 during start-up or over current fault condition.

100  $\mu$ Sec / div

100 mV / div

Fig 9

Q6 & Q7 collector current wave form across R-61 with the amplifier at full power into 8 $\Omega$  loads at 1kHz.

2 mSec / div

100 mV / div

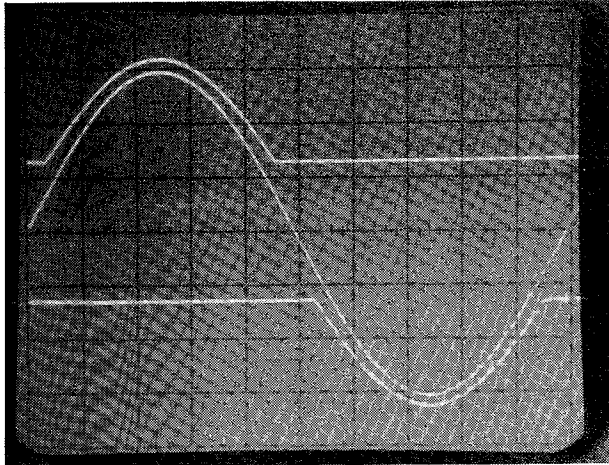

Fig 10  $\pm 55\text{V}$  commutators @ 2kHz

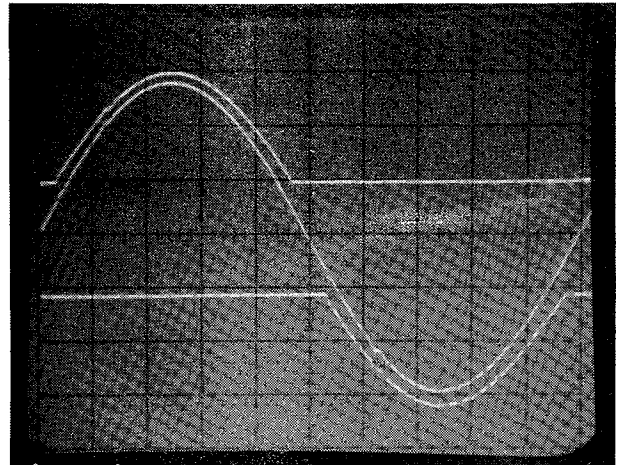

Fig 11  $\pm 55\text{V}$  commutators @ 10kHz

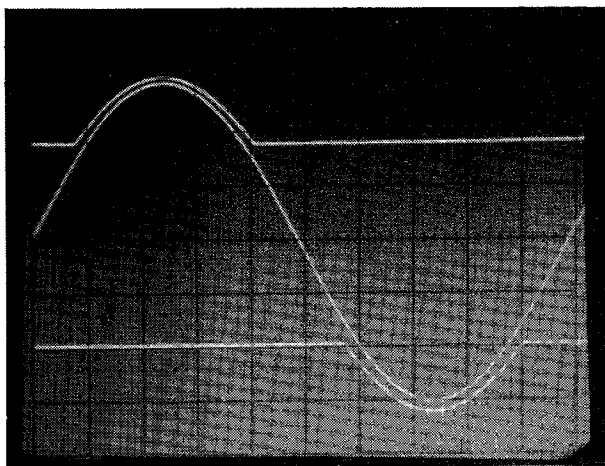

Fig 12  $\pm 80\text{V}$  commutators @ 2kHz

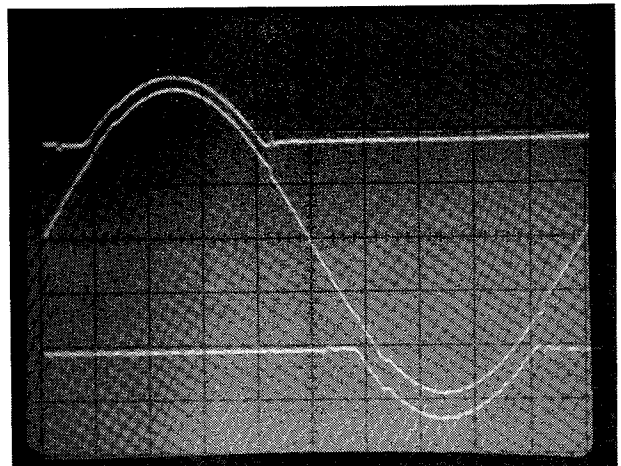

Fig 13  $\pm 80\text{V}$  commutators @ 10kHz

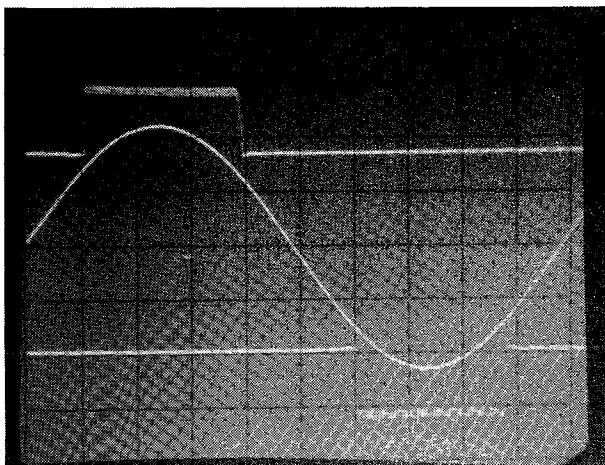

Fig 14  $\pm 125\text{V}$  commutators @ 2kHz

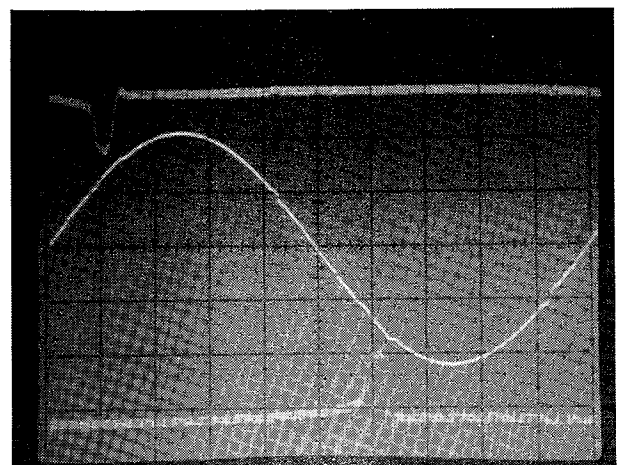

Fig 15  $\pm 125\text{V}$  commutators @ 10kHz

PM 2.0t  
SPECIFICATIONS

**POWER OUTPUT:**

465 Watts per channel 20-20kHz both channels driven with no more than 0.5% THD into 8 Ohms.  
600 Watts per channel 20-20kHz both channels driven with no more than 1.0% THD into 4 Ohms.  
450 Watts per channel 20-20kHz both channels driven into 2 Ohms.

**POWER OUTPUT in MONO CONFIGURATION:**

1000 Watts into 4 Ohms with no more than 0.5% THD

**POWER OUTPUT into 70.7 VOLT LINE SYSTEM**

450 Watts per channel with system impedance of 11 Ohms.  
900 Watts in mono with system impedance of 5.8 Ohms.

**IM DISTORTION:**

Less than 0.1% SMPTE.

**FREQUENCY BANDWIDTH:**

5HZ-40kHz  $\pm$  1 dB at 1 Watt output level.

**GAIN:**

29 dB with input level controls at maximum.

**INPUT SENSITIVITY:**

2.16 Volts RMS for rated power at 8 Ohms.

**NOISE:**

Better than 110 dB below 465 Watts A weighted.

**INPUT IMPEDANCE:**

15K Ohms each leg to ground on both XLR and TRS inputs.

**COMMON MODE REJECTION**

55 dB @ 2kHz 40 dB @ 20kHz

**DAMPING FACTOR:**

Greater than 200 at any frequency from 20-20KHZ.

**SLEW RATE:**

25 Volts /  $\mu$ sec.

**MOUNTING SYSTEM:**

Standard two space 19" rack mount with rear support.

**DIMENSIONS:**

Height - 3.5"  
Width - 19"  
Depth - 10.75"  
Weight - 10.6 lbs.

**NOTE:** To verify power ratings, the AC line voltage must be maintained at 120 Vac.

## APPENDIX A

### PRIMARY BOARD CIRCUIT CHANGES

Starting with serial number PS-1006 several value changes were made to improve performance and reliability under adverse conditions. These changes are listed below and are intended for reference only. For information concerning the updating of older units contact Carver Service.

Ref	Description	Changed to	Carver P/N	Qty
R2	6.8K 1/2W	200Ω 2W	253-20077-00	1
R3 <sup>1</sup>	8.2K 5W	7.5K 5W	253-40120-00	1
R6	43Ω 1/4W	1K 1/4W	251-00070-00	1
R10	1K 1/4W	5.1K 1/4W	251-00087-00	1
R17	1K 1/4W	1.5K 1/4W	251-00074-00	1
R21	1M 1/4W	330K 1/4W	251-00130-00	1
R33	7.5K 1/4W	4.3K 1/4W	251-00085-00	1
R47	1.8K 1/4W	910Ω 1/4W	251-00069-00	1
R58	3.6Ω 1/2W	3.9Ω 1/2W	251-10012-00	1
R60	3.6Ω 1/2W	3.9Ω 1/2W	251-10012-00	1
R62	36Ω 2W	33Ω 7W	253-50040-00	1
R67	1K 1/4W	270Ω 1/4W	251-00056-00	1
C9	.001μF	390pF	201-00022-00	1
C16	.082μF	.15μF	204-00069-00	1
C27	.0068μF	.033μF 630V	207-20007-00	1
C29	680pF	Delete		
D4	1N4148	.0015μF	204-20007-00	1
D	Added to ckt	1N4148	320-20001-00	1

NOTE 1 This part was changed after PS-1006.

APPENDIX B

EUROPEAN PRIMARY BOARD CHANGES

Ref	(120V version)	Changed to	Carver P/N	Qty
R1	24K 1/2 W	68K 1/2 W	251-00042-00	1
R2	200 2 W	820 2 W	256-20055-00	
R3	7.5K 5 W	15K 10 W	234-00034-00	1
R4	110K 1/4 W	300K 1/4 W	251-00129-00	1
R5	110K 1/4 W	300K 1/4 W	251-00129-00	1
R27	22K 1/4 W	19.1K 1/4W 1%	252-00412-00	1
R28	1.8K 1/4 W	2K 1/4 W	251-00077-00	1
R61	.008 5 W	.02Ω 2W	253-30003-00	1
R62	33Ω 7W	See Note	253-40004-00	2
R66	5.1K 1/4W	10K 1/4W	251-00094-00	1
C27	.033μF 1kV	See Note	207-20007-00	2
C31	910pF	390 pF 2kV	201-00122-00	1
C3	.01μF	.01μF 500V	201-00034-00	1
C4	10,000μF 90V	2,700μF 200V	205-00106-00	1
C5	10,000μF 90V	2,700μF 200V	205-00106-00	1
D12	1N4004	1N4007	320-20003-00	1
D13	1N4004	1N4007	320-20003-00	1
D14	1N4004	1N4007	320-20003-00	1
D15	1N4004	1N4007	320-20003-00	1
D16	1N4004	1N4007	320-20003-00	1
D17	1N4004	1N4007	320-20003-00	1
BR1	25A 200V	25A 400V	319-00059-00	1
Q6	MJ10023	MJ10025	321-30017-00	1
Q7	MJ10023	MJ10025	321-30017-00	1
F1	MDQ-10	MDX-5	315-12502-00	1

NOTE:

The snubber for this version is a dual network. Each switching transistor has it's own RC network which returns to the main B+ supply. Refer to the European power supply schematic for wiring details.

Due to the extensive differences between the 120V and 230V power supplies it is not practical to attempt voltage conversion. If a voltage change is necessary, the entire power supply modual must be changed.

## APPENDIX C

### CONVERSION TO MONO

To convert the PM 2.0t to parallel mono operation all that is required are jumper changes as shown below. With the 2.0t in the mono mode it is possible to drive low impedance loads to full rated power.

When the unit is wired in the mono mode, only the left channel input jacks and left channel level control are active. **If the PM 2.0t is used to drive a single load the red output binding posts must be wired together.**

### BIAS SETTING

With the jumpers in the mono position only the left channel bias pot is active. To set the bias, allow the unit to warm up for a few minutes at idle and check the left and right channel bias levels. While measuring the higher of the two channels, adjust RP-102 for 2 to 3 mV as outlined in the amplifier test procedures on page 8.

**CAUTION**  
IF THE AMPLIFIER IS CONVERTED BACK TO  
STEREO OPERATION THE RED BINDING POSTS  
MUST NOT BE CONNECTED TO EACH OTHER !!

Jumper location on  
the main amplifier  
board.

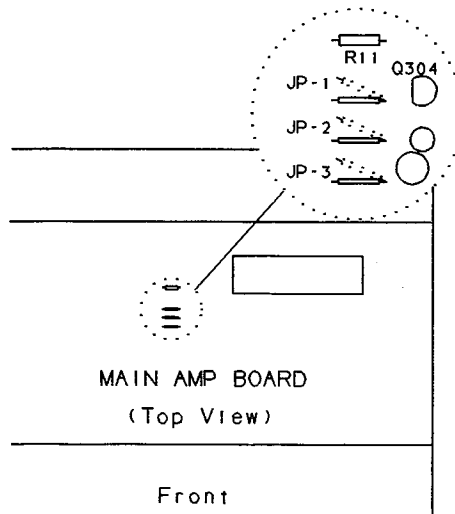

Stereo Mode:

All jumpers in the parallel position.

Mono Mode:

All jumpers in the diagonal position using the offset solder pads.

PM 2.0t

PARTS LIST

The part lists below are grouped by subassembly and contain only those items which would be difficult to obtain at a local jobber. For pricing and information on parts not listed contact Carver Service.

AMPLIFIER BOARD

Reference designator	Description	Carver P/N	Qty
Q1,Q110,Q310,Q104,Q304	MPS 8093	312-40003-00	5
Q2	2N4123	321-40010-00	1
Q101,Q301,Q107,Q307,Q108,Q308	MPSA43	321-40001-00	6
Q102,Q302,Q111,Q311	MPSA93	321-40004-00	4
Q103,Q303	MPSU60	321-20002-00	2
Q106,Q306	MPSU10	321-20001-00	2
Q105,Q305	MJE180	321-60007-00	2
Q109,Q309,Q124,Q324	MPS8097	321-40000-00	4
Q112,Q312,Q117,Q317	2N6490	321-60006-00	4
Q115,Q315,Q116,Q316	2N6488	321-60004-00	4
Q113,Q313,Q122,Q322,Q121,Q321	2SC3281	321-30013-00	10
Q120,Q320,Q123,Q323			
Q118,Q318,Q119,Q319	TIP35B	321-80000-00	4
Q114,Q314,Q125,Q325,Q126,Q326	2SA1302	321-30014-00	10
Q127,Q327,Q128,Q328			
Q129,Q329,Q130,Q330	TIP36B	321-80003-00	4
Q131,Q331	2N5458	321-40005-00	2
D132,D332,D134,D334,D135,D335	MR852	320-20007-03	12
D136,D336,D137,D337,D139,D339			
D116,D316,D117,D317,D112,D312	FDH400	320-20006-03	14
D115,D315,D111,D311,D108,D308			
D110,D310			
D1,D2	MR812	320-20002-03	2
IC1,IC2	TLO-72	330-30001-00	2
OC101,OC301	CLM-50	330-40003-01	2
R185,R186,R385,R386	.075Ω 3W	253-30002-00	4
R191,R391,R184,R384,R183,R383	.1Ω 2W	253-20001-00	8
R187,R387			
RP101,RP301	5KΩ Var	259-10024-00	2



PM 2.0t parts list continued

INPUT BOARD

Reference designator	Description	Carver P/N	Qty
U1,U2	TLO-72	330-30001-00	2
J1,J4	PC Mt TRS Jack	109-20001-00	2
J2,J3	PC Mt XLR Jack	109-00002-00	2

PRIMARY BOARD

Reference designator	Description	Carver P/N	Qty
Q1,Q2,Q3, Q4,Q5	MPS8097	321-40000-00	3
Q6,Q7	2N6488	321-60004-00	2
	MJ10023 <sup>1</sup>	321-30017-00	2
D12,D13,D14,D15,D16,D17	1N4004 <sup>2</sup>	320-20004-03	6
D18,D19,D20,D21	MR852	320-20007-03	4
U1	CA3524 <sup>3</sup>	330-60007-00	1
U2	LM339	330-30009-00	
U3	CNY-17	330-40002-00	
C4,C5	10,000 $\mu$ f <sup>4,7</sup>	205-00061-00	2
C32	10-150pF VAR CAP	208-00001-00	1
T1	TRANSFORMER <sup>5,7</sup>	617-10027-00	1
R61	.008 $\Omega$ 5W <sup>6</sup>	253-40004-00	1
SW1	DPDT 10A	318-50004-00	
SW2	100° C SWITCH <sup>7</sup>	318-20002-00	1

NOTES:

- 1 MJ10025 used on European version P/N 321-30018-00
- 2 1N4007 used on European version P/N 320-20003-00
- 3 Use only RCA part
- 4 2,700 $\mu$ F 200V used on European version P/N 205-00106-00
- 5 The European version uses P/N 617-10042-00
- 6 .02 $\Omega$  3W used on European version P/N 253-30003-00
- 7 Chassis mounted parts

PM 2.0t parts list continued

SECONDARY BOARD

Reference designator	Description	Carver P/N	Qty
Q1	MPS8097	321-40000-00	1
Q2,Q3,	2N4123	321-40010-00	2
Q4,Q5,Q6	2N4125	321-40009-00	3
Q7	MPS8093	321-40003-00	1
D8,D9,D10,D11	MR822 <sup>1</sup>	320-20015-03	4
D7,D8	MR504	320-20005-03	2
C13,C14	1000 $\mu$ F 160V <sup>2</sup>	205-00051-00	2
C11,C12	1800 $\mu$ F 80V <sup>2</sup>	205-00050-00	2
C9,C10	1500 $\mu$ F 63V <sup>2</sup>	205-00062-00	2
C7,C8	2200 $\mu$ F 25V <sup>2</sup>	205-00027-00	2

MISC PARTS

Reference designator	Description	Carver P/N	Qty
None	Filter pad	105-10004-00	
None	Fan Motor	112-10003-00	
None	Rear mtg bracket	507-00024-01	

NOTES:

- 1 MR852 used in earlier units
- 2 These parts have a height limit of 1.6 in.

For items not listed or technical assistance contact Carver Service at the address below.

Carver Corporation  
 PO Box 1237  
 Lynnwood, WA 98046-1237

Phone (206) 775-6245

NOTES

This page left blank for notes and test procedure changes.