

CARVER

Model TFM-15 SERVICE MANUAL

For TFM-15CB
Use TFM-15CB Schematic
Diagram Insert

CONTENTS

	Page
1. IMPORTANT SAFETY INFORMATION.....	2
2. SPECIFICATIONS.....	2
3. BLOCK DIAGRAM.....	3
4. ALIGNMENT PROCEDURES.....	4
5. SCHEMATIC DIAGRAMS.....	5-6
6. EXPLODED VIEW.....	7-8
7. EXPLODED VIEW PARTS LIST.....	9
8. PCB COMPONENT SIDE VIEWS AND PARTS LIST.....	10-13

1. IMPORTANT SAFETY INFORMATION

WARNING.

Any person performing the procedures described in this manual will be exposed to hazardous voltages and the risk of electric shock.

Carver Corporation assumes that any person who removes the cover from the unit has been properly trained in protecting against avoidable injury and shock.

Therefore, the procedures described here are to be performed by qualified electronics service personnel only.

We recommend that the unit be tested only when line isolation is provided by an isolation transformer. The line cord of the unit must be disconnected and **the power supply capacitors fully discharged** before any components are replaced. Failure to do so may result in severe damage to the unit and the risk of electric shock.

2. SPECIFICATIONS

Power:

100 watts RMS per channel into 8 ohms both channels driven 20-20KHz with no more than 0.1% THD.
140 watts RMS per channel into 4 ohms both channels driven 20-20KHz with no more than 0.1% THD.
200 watts dynamic power into 2 ohms

Frequency Response:

+0, -0.3dB 20-20KHz

Noise:

110dB A-weighted referenced to rated power

Gain:

31 dB (with input level controls fully clockwise)

Input impedance:

30K ohms

Power Requirements:

120 VAC, 60Hz, USA & Canada
220 VAC, 50Hz, Europe

Dimensions:

3-5/8" x 19" x 13"
92mm x 482mm x 332mm

Weight:

17.2 lbs
7.8 kgs

3. BLOCK DIAGRAM

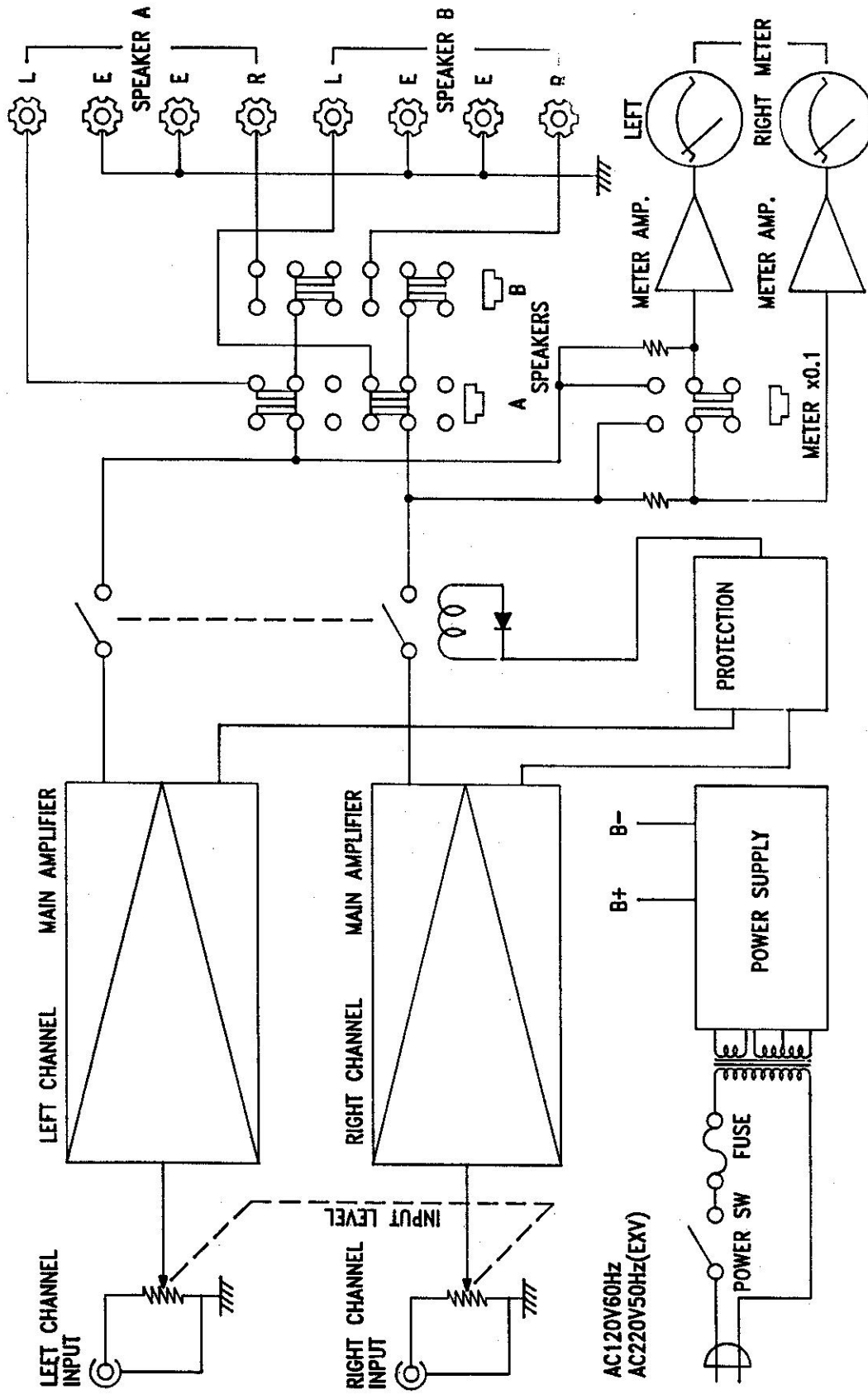

4. ALIGNMENT PROCEDURES

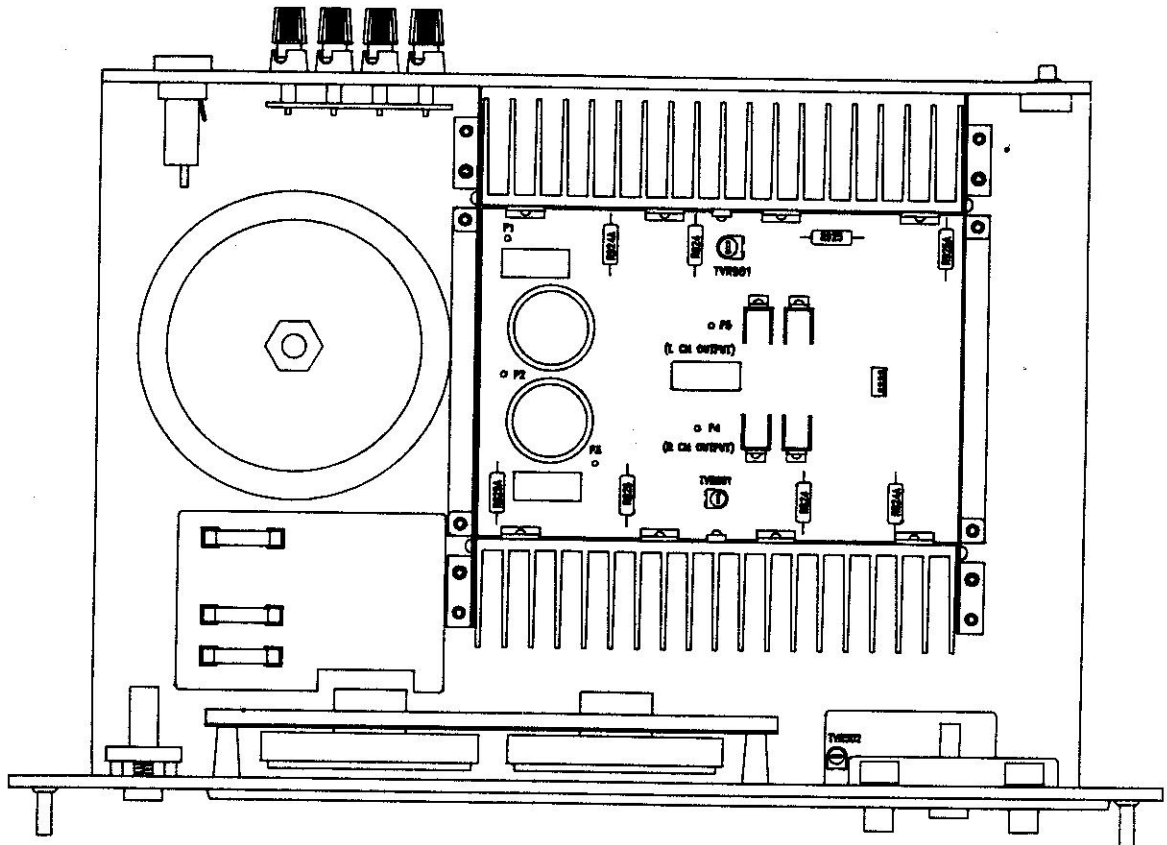

1-1 DC BALANCE CHECK

1. Connect a DC voltmeter to the right Speaker A terminals.
2. Push in the POWER switch and the SPEAKER A switch.
3. Verify less than $\pm 20\text{mV}$ on the meter.
4. Repeat for the left Speaker A terminals.

1-2 IDLING CURRENT CHECK

Note: These measurements should be made shortly after turning the amplifier on, while it is relatively cool.

1. Set LEVEL control to minimum (CCW).
2. Connect a DC voltmeter across R824.
3. Verify 5mV ($\pm 1\text{mV}$) on the meter. Readjust TVR801 if necessary.
4. Measure the voltage across R824A, R825 and R825A and verify 5mV ($\pm 1\text{mV}$) across each resistor.
5. Connect a DC voltmeter across R924.
6. Verify 5mV ($\pm 1\text{mV}$) on the meter. Readjust TVR901 if necessary.
7. Measure the voltage across R924A, R925 and R925A and verify 5mV ($\pm 1\text{mV}$) across each resistor.

1-3 RELAY OPERATION CHECK

1. Apply a 1KHz sine wave at 750mV (-2.5dBV) to the LINE input jacks.
2. Adjust the right LEVEL control so that the output voltage is 27.5Vrms at the right SPEAKER A terminal, with an 8 ohm load.
3. Short circuit the right SPEAKER A terminals and verify that the relay cuts off immediately.
4. Repeat for the left SPEAKER A terminals.

1-4 METER ADJUSTMENT

1. Apply a 1KHz sine wave at 500mV (-6dBV) to the LINE input jacks.
2. Adjust the right LEVEL control to maximum (CW).
3. Set the METER RANGE switch to the OUT position.
4. Readjust the input voltage for 20Vrms at the right SPEAKER A terminals, with an 8 ohm load (50W into 8 ohms).
5. Verify the right meter indicates 50W. Readjust TVR 501 if necessary.
6. Repeat for the left channel.

6. EXPLODED VIEW

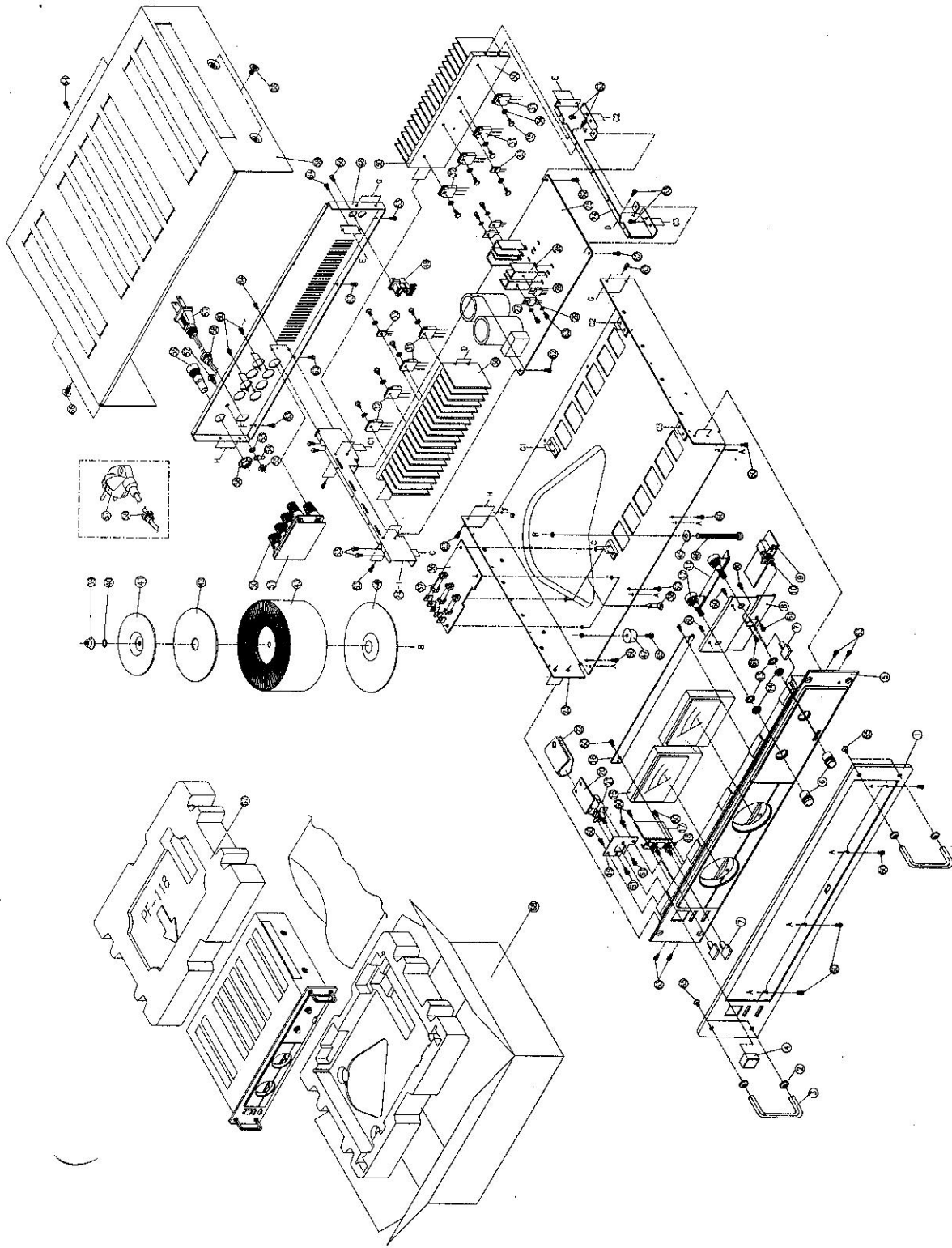

8: PCB COMPONENT SIDE VIEWS AND PARTS LIST

8-1 PC BOARD B770-MA

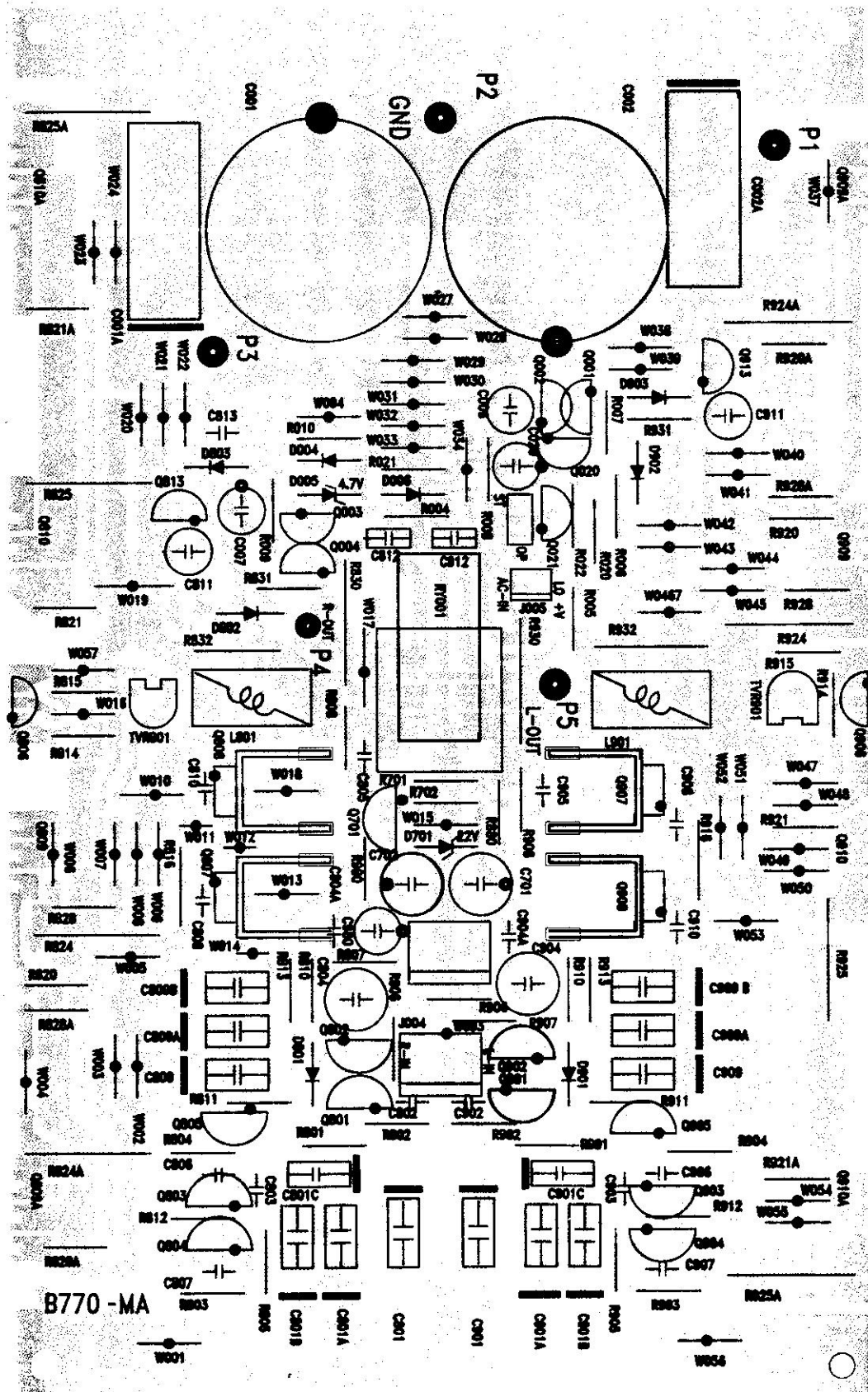

B770-MA

7. EXPLODED VIEW PARTS LIST

REF. NO.	DESCRIPTION	P/N	Q'TY	REMARK
1.	AL FRONT PANEL L-324	75L324EBG1	1	
2.	AL PAD FOR HOLDER H-214	76H214B***	4	
3.	HOLDER H-213	76H213B***	2	
4.	PUSH KNOB KN-260 (B) FOR POWER	80260B****	1	
5.	PLASTIC FRONT PANEL A-346-1	79A346BHC*	1	
6.	KNOB KB-264 (B)	80264B****	2	
7.	PUSH KNOB KB-263 (B)	80263B****	3	
8.	VR HOLDER C-1445	78C1445FEW	1	
9.	PCB B771-MT	60B771MTV0	1	
10.	PUSH SWITCH SPUF12AA05	20UF12AA05	1	
11.	PCB B771-VOL	60B771VOLO	1	
12.	VR RK163111R382-50KAx25KC	3250KA25KC	2	
13.	WASHER 7φ	88WF07P14W	1	
14.	NUT 7φ	88N607W***	1	
15.	AMPERE METER TN-90-8779	64TN908779	2	
16.	METER HOLDER C-1444	78C1444TEW	1	
17.	PCB B771-SW2	60B771SW20	1	
18.	PUSH SW SPUN24C201	20UN24C201	1	
19.	POWER SW HOLDER C-1446	78C1446FEW	1	
20.	PCB B771-SW1	60B771SW10	1	
21.	AC SWITCH SDDL1027U-W	20DLB1027U	1	
22.	UL TUBE 33φx40	6233L40VW1	1	
23.	BOTTOM CHASSIS C-1451	78C1451FEW	1	
24.	HOLDER OF HEAT SINK (R) C-1453	78C1453W**	1	
24-1.	HOLDER OF HEAT SINK (L) C-1454	78C1454W**	1	
25.	PCB B770-MA	60B770MAV0	1	
26.	HEAT SINK H-042	76H042W***	4	
27.	TR. 2SC2167	122SC2167*	2	
28.	TR. 2SA957	122SA957**	2	
29.	WASHER 3φ	88WF03P8**	4	
30.	HEAT SINK H-216	76H216W***	2	
31.	TR. 2SA1386	122SA1386*	4	
32.	TR. 2SC3519	122SC3519*	4	
33.	TR. 2SC3423	122SC3423*	2	
34.	GEAR WASHER 3φ	88WG03P6**	10	
35.	HEXAGON CRTS 3x15 (Y)	88SW0315RY	10	
36.	PCB B771-PW	60B771PWV0	1	
37.	FUSE 6.3φx31.7x1A	59UL001A2F	1	(B771-PW)
38.	FUSE 6.3φx31.7x8A	59UL008A1F	2	(B771-PW)
39.	PLASTIC POST FOR PCB SCB-24	96SCB24***	4	
40.	NUT M6	88N606W***	1	
41.	TOOTHED LOCK WASHER	88WG0306**	1	
42.	CHASSIS SPC. 83m/mx2m/m	7883X2T***	1	
43.	RUBBER 96m/mx14m/mx1.5m/m	84961415**	1	
44.	RING TRANSFORMER 120V R54037U212CV	R54037U212	1	
45.	RING TRANSFORMER 220V R54037V212CV	R54037V212	1	
46.	RUBBER 116m/mx14m/mx1.5m/m	84116145*	1	
47.	WASHER 8x14x1.5	88WF08014*	1	
48.	CROSS RECESSED HEAD BOLT M65m/m	88SM0665RB	1	
49.	FOOT CUSHION 18φx10m/m	81018X10**	4	
50.	REAR PANEL C-1452	78C1452***	1	
51.	RCA JACK #202-1	552R202***	1	
52.	SPEAKER TERMINAL 8DP-208A	555BDD208A	1	
53.	PCB B771-SP	60B771SP**	1	
54.	GROUND SCREW GRMS 4x10 (W)	88SW0410RW	1	EXV
55.	WASHER 4φ	88WF04P101	1	
56.	SOLDER 4φ	88SF04****	1	
57.	NUT 4φ	88N604W***	1	
58.	FUSE HOLDER R3-13	67R313IUL**	1	
59.	FUSE 6.3φx31.7x5A	59U1005A1F	1	
60.	FUSE 5φx20x3.15A	59U23P1A2F	1	
61.	AC CORD SPT-2 #18	682XPT22B*	1	EXV
62.	AC CORD 3P VDE	682PVDE2B*	1	EXV
63.	BUSHING B-7	96B7*****4	1	
64.	BUSHING 5N4	965N4****4	1	
65.	UPPER COVER C-1471	78C1471W**	2	
66.	PLASTIC SCREW 1/8x9 (B)	88SPE809RB	22	
67.	SCREW CRMS 3x6 (Y)	88SM0306RY	4	
68.	SCREW CRMS 3x8 (Y)	88SM0308RY	4	
69.	SCREW CRTS 3x6 (Y)	88ST0306RB	4	
70.	SCREW CRTS 3x6 (B)	88ST0306RB	6	
71.	SCREW CRWMS 4x8 (B)	88SM0408RB	8	
72.	SCREW CRWMS 4x6 (B)	88SM0406RB	4	
73.	STYROFOAM PF-118	90PF118***	2	
74.	CARTON	93TFM15***	1	
75.	OWNER'S MANUAL	91TFM15***	1	

P.C. BOARD B770-MA ASS'Y

REF. NO.	DESCRIPTION	P/N	Q'TY
	HEAT SINK H-042 (W) FOR 2SC2167, 2SA957	76H042W***	4
	HEAT SINK H-216	76H216W***	2
	HOLDER OF HEAT SINK (RIGHT) C-1453	78C1453W**	1
	HOLDER OF HEAT SINK (LEFT) C-1454	78C1454W**	1
	CONNECTOR E-D255	66ED255***	1
	SPRING WASHER 3φ (Y)	88WS03P6**	8
	SCREW CRTS 3x8 (Y)	88ST0308RY	4
	SCREW CRTS 3x6 (Y)	88ST0306RY	12
	HEXAGON CRTS 3x15 (Y)	88ST0315RY	8
	WAFER 5045-2	6650452***	1
	WAFER 5045-4	6650454***	1
	PIN 1x1x19	65010119**	3
	RELAY 12V 5A 2P2C	6112052P2C	1
	COIL 17-1/2Tx6φx1MM	73C17P5061	2
-CARBON RESISTORS T TYPE-			
ALL RESISTORS ARE RATED ±5% TOLERANCE AND 1/4W			
R820, R820A, R821, R821A	10 ohm	300010C4TJ	
R920, R920A, R921, R921A	10 ohm	300010C4TJ	
R810, R812, R813, R910, R912, R913	150 ohm	300150C4TJ	
R007	220 ohm	300220C4TJ	
R010, R805, R905	470 ohm	300470C4TJ	
R009, R815, R915	1K ohm	30001KC4TJ	
R807, R907	1K5 ohm	3001K5C4TJ	
R701, R801, R901	2K2 ohm	3002K2C4TJ	
R803, R804, R903, R904	3K3 ohm	3003K3C4TJ	
R814, R914	3K9 ohm	3003K9C4TJ	
R828, R828A, R928, R928A	4K7 ohm	3004K7C4TJ	
R702	5K6 ohm	3005K6C4TJ	
R004, R005	15K ohm	30015KC4TJ	
R811, R911, R831, R931	22K ohm	30022KC4TJ	
R806, R906	33K ohm	30033KC4TJ	
R006	47K ohm	30047KC4TJ	
R808, R908	56K ohm	30056KC4TJ	
R802, R902	100K ohm	30100KC4TJ	
R008	330K ohm	30330KC4TJ	
-CARBON RESISTORS T TYPE-			
ALL RESISTORS ARE RATED ±5% TOLERANCE AND 1/2W			
R832, R932	4.7 ohm	3004P7C2TJ	
R816, R916	300 ohm	300330C2TJ	
-METAL RESISTORS T TYPE-			
ALL RESISTORS ARE RATED ±5% TOLERANCE 2W			
R830, R930	10 ohm	300010M2TJ	
R824, R824A, R825, R825A	0.33 ohm	300P33M2TJ	
R924, R924A, R925, R925A	0.33 ohm	300P33M2TJ	
-CAPACITORS-			
C806, C906, C807, C907	10P/500V	CERAMIC	42010500RJ
C805, C905	30P/500V	CERAMIC	42030500RJ
C808, C908, C810, C910	70P/500V	CERAMIC	42070500RJ
C803, C903	300P/500V	CERAMIC	42300500RJ
C813	.022/50V J	MYLAR	41223050RJ
C802, C902	150P/50V J	P.S.	43150050TJ
C007	33u/16V	ELEC.	40033U16RM
C701, C702	220u/25V	ELEC.	40220U25RM
C811, C911	4.7u/25V	ELEC. NP	404P7U25NP
C006, C804, C904	220u/16V	ELEC. NP	40220U25NP
C001, C002	15000u/50V	ELEC.	4015KU50RM
C801, C901	4.7K/160V	MPE F TYPE YELLOW	444P7UMPEF
C812, C912	0.047K/160V	MPE D TYPE BLUE	44473MPEED
C801A, C901A, C809	0.01K/100V	P/S C TYPE WHITE	44103100PS
C809A, C909, C909A	0.01K/100V	P/S C TYPE WHITE	44103100PS
C001A, C002A	0.1K/100V	P/S C TYPE WHITE	44104100PS
C801B, C901B	0.1K/160V	MPP D TYPE BLUE	44104160PD
C809B, C909B	0.1K/160V	PMT T TYPE YELLOW	44104160PT
-TRANSISTORS-			
Q801, Q802, Q901, Q902	2SA970		122SA970**
Q803, Q804, Q903, Q904	2SC2229		122SC2229*
Q805, Q905	2SA949		122SA949**
Q004, Q806, Q906	2SC468		122SC468**
Q807, Q907	2SC2167		122SC2167*
Q808, Q908	2SA957		122SA957**
Q001, Q002, Q003, Q701	2SC1815		122SC1815*
Q813, Q913	2SC1815		122SC1815*
Q809, Q809A, Q909, Q909A	2SC3519		122SC3519*
Q810, Q810A, Q910, Q910A	2SA1386		122SA1386*
-DIODE-			
D801, D802, D803, D004	1N4148		131N4148TO
D901, D902, D903	1N4148		131N4148TO
D005	4.7V/0.5W		132047P5TO
D701	22V/0.5W		132220P5TO
D003	1N4002		131N4002TO
-COIL-			
	17-1/2Tx6φx1MM		73C17P5061
-TVR-			
TVR801, TVR901	3 PIN 6φ 1K		31102083HS

MODEL: TFM-15cb

PARTS LIST

NO.	DESCRIPTION	P/N
1.	REAR PANEL, C-1786(TFM-15cb SW)	78C1786
2.	TRANSFORMER(TFM-15cb SW)	70TFM15SW
3.	SLIDE SWITCH, SL13B-022	22SL13B022
4.	SLIDE SWITCH, SL14-22AM(TFM-15cb SW)	22SL1422AM
5.	RESISTOR 10K OHM 1/4W T-TYPE	30010KC4TJ
6.	RESISTOR 47K OHM 1/4W T-TYPE	30047KC4TJ
7.	CAPACITOR 4.7UF 50V ELEC NP	404P7U50NP
8.	CONNECTOR E-D430	85ED430***

B771-PW

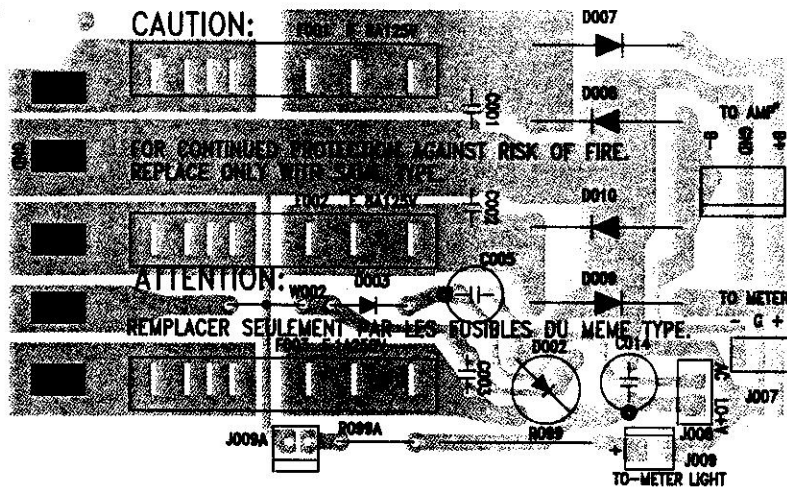

B771-VOL

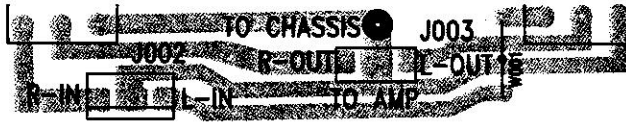

B771-SP

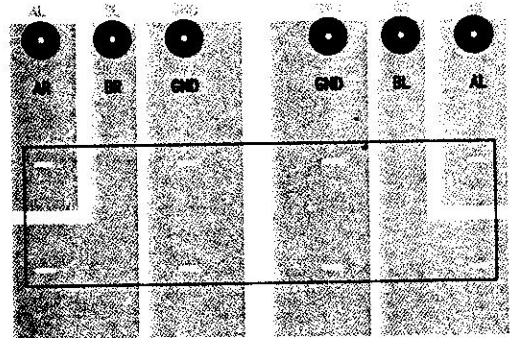

P.C. BOARD B771-PW ASS'Y

REF. NO.	DESCRIPTION	P/N	Q'TY
	CONNECTOR E-D319	66ED319***	1
	CONNECTOR E-D324	66ED324***	1
	FUSE HOLDER ØØ	67R313UL**	6
	WAFER 5273-3	6652733***	1
	WAFER 5045-2	6650452***	1
-CARBON RESISTORS T TYPE-			
ALL RESISTORS ARE RATED ±5% TOLERANCE AND 1/2W			
R099	10 ohm	300010C2TJ	
-CAPACITORS-			
C001, C002, C003	.005/500V CERAMIC	42502500RK	
C003	10u/25V ELEC.	44010U25RM	
C014	1000u/25V ELEC.	4401KU24RM	
-DIODE-			
D003	1N4004 RECTIFIER	121N4002TO	
D002	RC-202 BRIDGE RECTIFIER	13RC202***	
D007-D010	6A2 RECTIFIER	136A2*****	

P.C. BOARD B771-VOL ASS'Y

REF. NO.	DESCRIPTION	P/N	Q'TY
	VR RK163111R382-50KAx25KC	3250KA25KC	2
	WAFER 5045-4	6650454***	1
	CONNECTOR E-D316	66ED316***	1
	P.V.C. WIRE #24 90MM		1

P.C. BOARD B771-SP ASS'Y

REF. NO.	DESCRIPTION	P/N	Q'TY
	SPEAKER TERMINAL BDP-208A	555BDP208A	1
	PIN 1x1x19	65010119**	6

8-3 PC BOARD 771-MT, B771-RCA, B771-SW1, B771-SW2

B771-MT

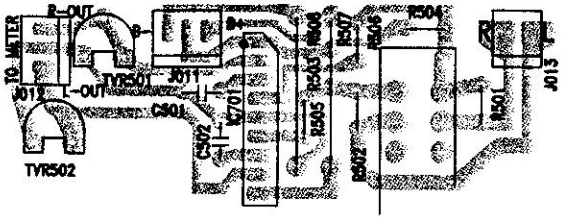

B771-SW1

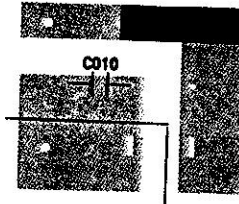

B771-RCA



B771-SW2

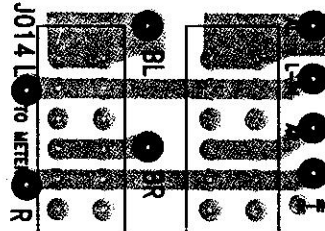

P.C. BOARD B771-MT ASS'Y

REF. NO.	DESCRIPTION	P/N	Q'TY
	PUSH SWITCH SPUF12AA05	20UP12AA05	1
	WAFER 5045-2	6650452***	1
	WAFER 5045-3	6650453***	2
	-CARBON RESISTORS F TYPE-		
	ALL RESISTORS ARE RATED $\pm 5\%$ TOLERANCE AND 1/4W		
R503, R504	5K6 ohm	3005K6C4TJ	
R501, R502	10K ohm	30010KC4TJ	
R505, R506	22K ohm	30022KC4TJ	
	-METAL RESISTORS T TYPE-		
	ALL RESISTORS ARE RATED $\pm 5\%$ TOLERANCE AND 2W		
R507, R508	2K2 ohm 2W	3002K2M2TJ	
	-CAPACITORS-		
C501, C502	.0068/50V MYLAR	41682250RJ	
	-IC-		
IC701	TA7318	11TA7318**	
	-VARIABLE RESISTORS-		
TVR501, TVR502	500 ohm H TYPE 3 PIN 6 ϕ	31500083HS	

P.C. BOARD B771-RCA ASS'Y

REF. NO	DESCRIPTION	P/N	Q'TY
	RCA JACK #202-1	552R2021**	1
	CONNECTOR E-D267	66ED267***	1
	P.V.C. WIRE #22 1015		1

P.C. BOARD B771-SW1 ASS'Y

REF. NO.	DESCRIPTION	P/N	Q'TY
	AC SWITCH SDDL81027U-W	20DL81027U	1
	-CAPACITORS-		
C010	.0047/125V UL,VDE	42472250VU	

P.C. BOARD B771-SW2 ASS'Y

REF. NO.	DESCRIPTION	P/N	Q'TY
	PUSH SW SPUN24C201	20UN24C201	1
	CONNECTOR E-D270	66ED270***	1
	P.V.C. WIRE		1

**CARVER CORPORATION
SERVICE BULLETIN**

Service Bulletin # TFM-15CB-3

Model: TFM-15CB

Serial Nos. _____

REASON: New schematic diagram shows bridged mono and daisy-chain circuits.

Date: 10/26/93

DELETE

ADD

PROCEDURE

Please insert the attached revised schematic diagram into your TFM-15 Service Manual.

Service Approval

[Signature] 10/26/93

Engineering Approval

[Signature] 10-26-93

5. SCHEMATIC DIAGRAMS
 CARVER TFM-15CB

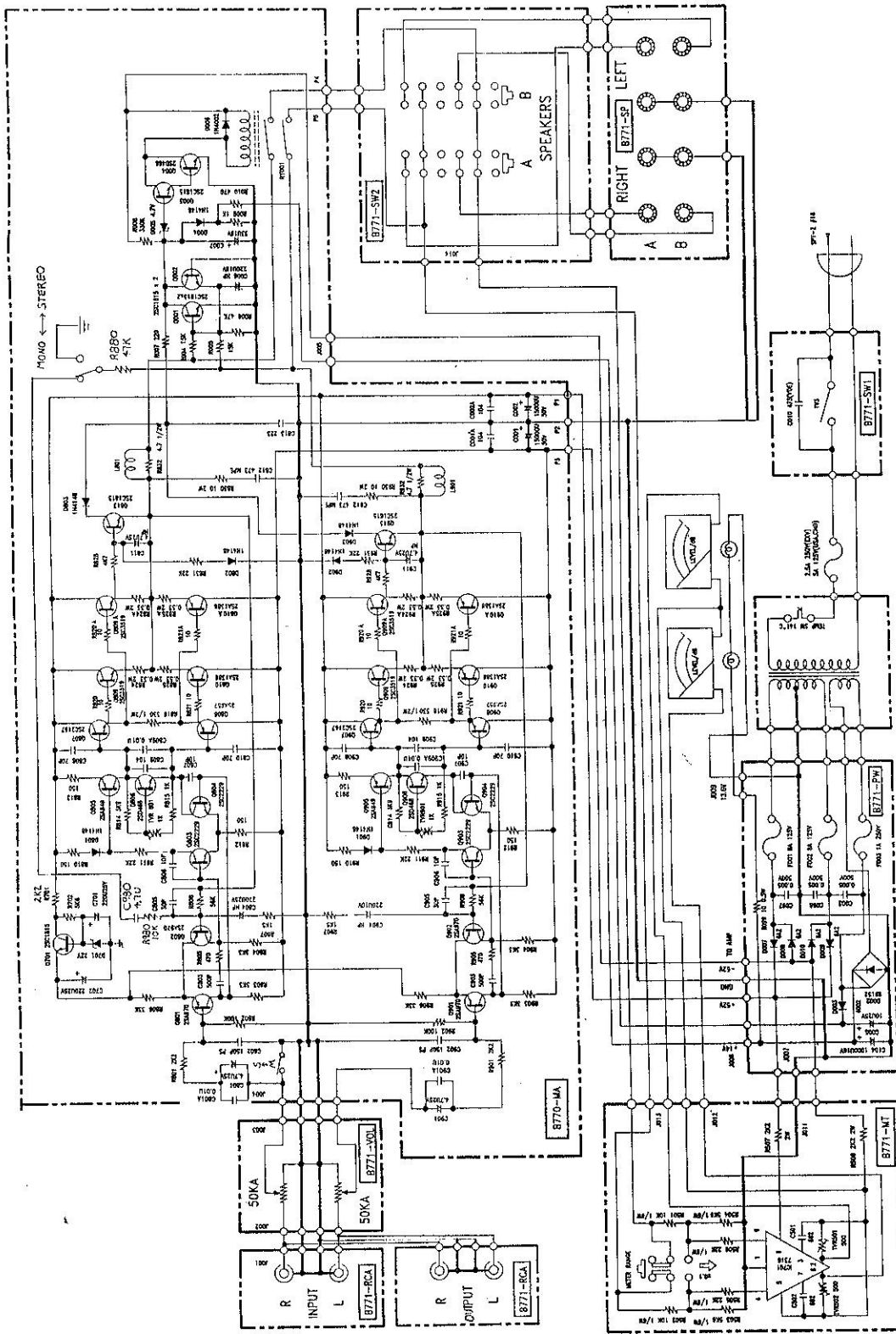

**CARVER CORPORATION
SERVICE BULLETIN**

Service Bulletin # TFM-15CB-3

Model: TFM-15CB

Serial Nos. _____

REASON: New schematic diagram shows bridged mono and daisy-chain circuits.

Date: 10/26/93

DELETE

ADD

PROCEDURE

Please insert the attached revised schematic diagram into your TFM-15 Service Manual.

Service Approval

[Signature] 10/26/93

Engineering Approval

[Signature] 10-26-93

5. SCHEMATIC DIAGRAMS
 CARVER TFM-15CB

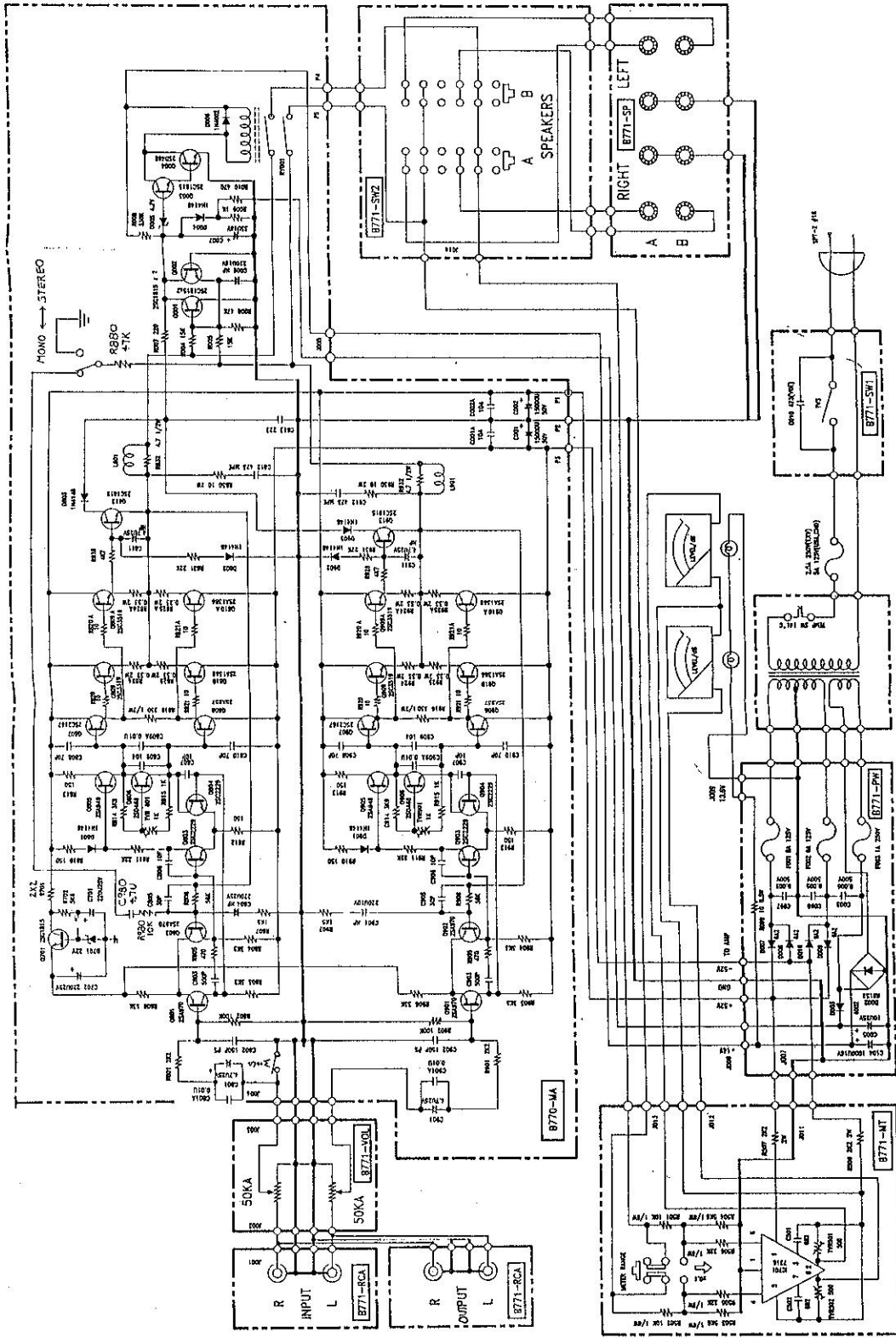

TFM-15cb VOLTAGE CONVERSION

230 Volt Operation

- 1. DISCONNECT THE TFM-15cb FROM THE AC POWER OUTLET.**
 - 2. Locate the AC SELECTOR switch on the back panel. Set the switch to the 230V position.**
 - 3. Unscrew the fuseholder cap and replace the fuse with 3.15 amp time delay fuse.**
 - 4. Install the 230V adaptor on the TFM-15cb AC plug.**
-

110-120 Volt Operation

- 1. DISCONNECT THE TFM-15cb FROM THE AC POWER OUTLET.**
- 2. Locate the AC SELECTOR switch on the back panel. Set the switch to the 115V position.**
- 3. Unscrew the fuseholder cap and replace the fuse with a 5 amp time delay fuse.**
- 4. Remove the adaptor from the TFM-15cb AC plug.**

TFM-15cb

Owner's Manual Addendum

Bridged Mono Operation

To use the TFM-15cb as a 280 watt mono power amplifier:

IMPORTANT: Turn the TFM-15cb power off before changing any connections.

1. Connect the speaker (-) wire to the red RIGHT speaker terminal on the TFM-15cb.
 - Connect the speaker (+) wire to the red LEFT speaker terminal on the TFM-15cb.
2. **For stereo operation** (2 TFM-15cb's required):
 - Connect the preamplifier LEFT output to the LEFT input jack on the TFM-15cb.
 - Connect the preamplifier RIGHT output to the LEFT input jack on the second TFM-15cb.**For mono operation** (center channel or subwoofer):
 - Connect the preamplifier or processor output to the LEFT input jack on the TFM-15cb.
3. Set BRIDGE/STEREO switch on the back of the TFM-15cb to the BRIDGE position.
4. Use the left input level control on the TFM-15cb to adjust the input sensitivity (see page 11). The right input level control on the TFM-15cb is disabled in bridged mono mode.

CARVER