

1

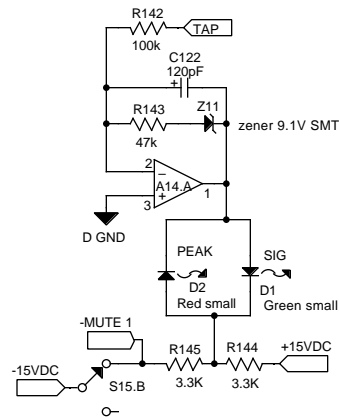
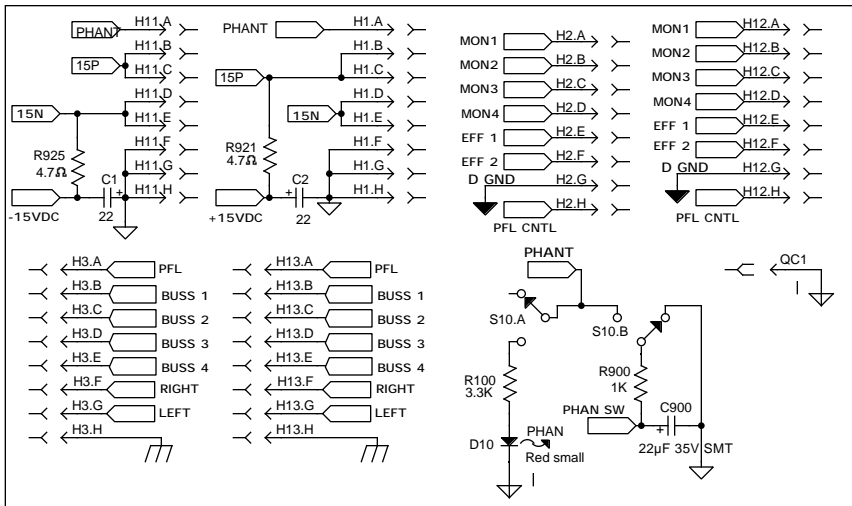

REFERENCE DESIGNATORS ARE IDENTIFIED BY THE FIRST DIGIT.

CHANNEL 1 ARE THE 100'S, IE: R102, C123  
 CHANNEL 2 ARE THE 200'S, IE: R202, C223  
 CHANNEL 3 ARE THE 300'S, IE: R302, C323  
 CHANNEL 4 ARE THE 400'S, IE: R402, C423  
 CHANNEL 5 ARE THE 500'S, IE: R502, C523

<b>CARVIN</b>		12340 World Trade Drive San Diego, CA 92128 (858) 487-1600 FAX 521-6032	
<b>C164 SERIES MIXER 8 CHANNEL INPUT PCB</b>			
DRAWN BY:	ERIC PETERSEN	DATE:	04JUN01
APPROVED:		DATE:	
PCB NO:	30-16441	REV:	C
ASSY. NO:	80-16441	REV:	A
REVISED BY:	ERIC PETERSEN	DATE:	29AUG01