

**AUDIMAX<sup>®</sup> III**  
**AUDIMAX<sup>®</sup> III S**  
**Automatic level control**  
OPERATING AND MAINTENANCE INSTRUCTIONS

May, 1967

**PROFESSIONAL  
PRODUCTS**  
 **CBS LABORATORIES**  
Stamford, Connecticut  
A Division of Columbia Broadcasting System, Inc.

## SECTION V - MAINTENANCE

5-1	GENERAL	5-1
5-2	SERVICING THE MAIN AMPLIFIER	5-1
5-3	SERVICING THE GATED GAIN STABILIZER	5-3
5-4	SERVICING THE LOGIC BOARD AND MEMORY UNIT	5-4
5-5	TRANSIENT PERFORMANCE	5-5
5-6	BULB REPLACEMENT	5-6

## SECTION VI - PARTS LIST

AUDIMAX III	6-1
STEREOPHONIC ADAPTER	6-5

## LIST OF ILLUSTRATIONS

FRONTISPIECE	iii
FIGURE 4.1 AUDIMAX III, MODEL 444, BLOCK DIAGRAM	4-2
FIGURE 4.2 FUNCTIONAL DIAGRAM	4-5
FIGURE 4.3 STEREOPHONIC ADAPTER SCHEMATIC DIAGRAM	4-10
FIGURE 4.4 AUDIMAX III, MODEL 444, SERIAL NUMBERS 101 THROUGH 200, SCHEMATIC DIAGRAM	4-12
FIGURE 4.5 AUDIMAX III, MODEL 444, SERIAL NUMBERS 201 AND ABOVE, SCHEMATIC DIAGRAM	4-13

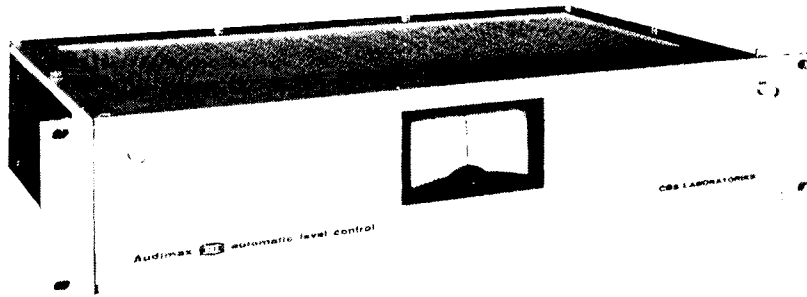

AUDIMAX III, MODEL 444

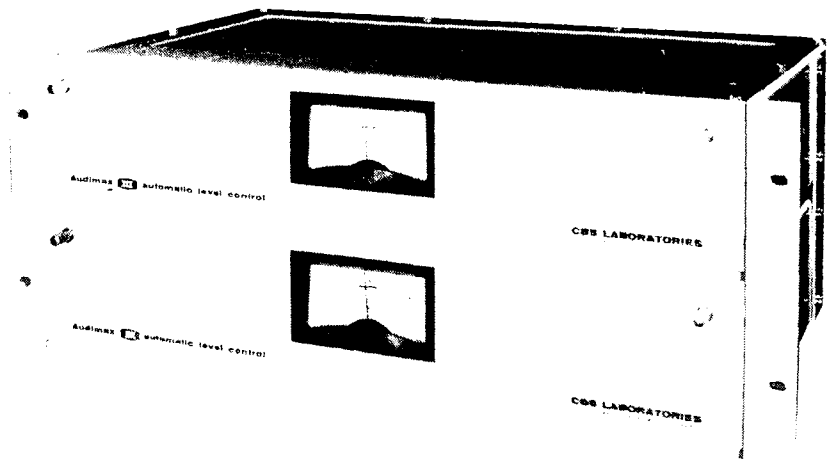

AUDIMAX III S, MODEL 445

SECTION I  
INTRODUCTION

1-1 GENERAL

The new solid-state Audimax<sup>R</sup>III, Model 444, like its companion piece, Volumax<sup>TM</sup>, is a tool to help the broadcaster achieve maximum program power within appropriate modulation limits. Incorporating all of the features of its famous predecessor, the Audimax III also provides additional gain and versatility. Designed for use wherever high quality automatic gain riding is required, Audimax III offers a unique method of audio control for AM, FM, and TV broadcasting, recording, motion pictures and public address use.

Audimax III is the latest development in the unique Audimax system of audio control developed by CBS Laboratories. Applicable to all audio media, the Audimax is totally different in concept from ordinary compressors, limiters or AGCs. The Audimax acts like a highly capable studio technician, but without many human limitations. Valuable in the studio, the Audimax is often more valuable outside, away from controlled studio conditions. The ability of the Audimax to act instantly and control audio levels intelligently frees engineers to cope with the many other problems of remote pick-ups.

The new solid-state Audimax III offers the ultimate in automated gain control combined with the extreme reliability of solid-state circuitry. The exclusive GAIN PLATFORM principle permits gain to remain on a stable plateau over a wide range of input levels rather than continuously

allowing it to rise and fall with consequent distortion, thumping and pumping, and audio "holes". Its unique GATED GAIN STABILIZER acts to bridge through program lapses and thus eliminate "swish-up" of background noise. A special RETURN-TO-ZERO function returns gain to normal during standby conditions.

These Audimax principles apply not only to radio and television stations, but also are necessary in recording, public address, background music, and two-way communication systems as well.

#### 1-2 WARRANTY

A warranty, with a return post card is included with your Audimax III. Fill out the post card and return it to CBS Laboratories as soon as possible to validate your warranty.

#### 1-3 FACTORY SERVICE AND REPAIR

If you should experience difficulty in installing, operating, or repairing Audimax III, please contact CBS Laboratories, Professional Products, Stamford, Connecticut (Area Code 203) 327-2000.

1-4 SPECIFICATIONS

AUDIMAX III, Model 444

Frequency Response	Flat within 1 dB from 50 to 15,000 Hz*
Harmonic Distortion	Below 1% from 50 Hz to 15,000 Hz at +16 dBm output
Noise Level	Below -60 dBm output, with NORMAL gain
Control Characteristic	±10 dB of gain control
Gated Gain Stabilization	Threshold adjustable from -20 dB to normal input
Maximum Gain	50 dB**
Input and Output Impedances	600 ohms, balanced or unbalanced (150 ohms on special order)
Minimum Input Level	-30 vu**
Normal Output Level	+11 vu
Maximum Output	+25 dBm
Maximum Operating Temperature	55°C
Physical Dimensions	Standard 19" rack mounting, 3-1/2" high, 9-5/8" deep
Power Requirements	30 watts at 115/230 volts ac, 50-60 Hz

AUDIMAX III, Model 445, (Stereo)

Physical Dimensions	Standard 19" rack mounting, 7" high, 9-5/8" deep
Power Requirements	15 watts at 115/230 volts ac, 50-60 Hz

\* Hz, abbreviation for Hertz, has been adopted as the new engineering term for cycles per second. KHz is 100 cps.

\*\* As delivered, Audimax III contains a 20 dB fixed attenuator in the input circuit. Removal of this pad will permit user to realize specified maximum gain and minimum input level.

## SECTION II

## INSTALLATION PROCEDURES

## 2-1 UNPACKING

Carefully unpack your Audimax III and examine the unit for any evidence of physical damage that may have occurred during shipment. In the event of damage file a claim immediately with the carrier. If future transportation of the unit is anticipated, save the shipping carton for reuse.

## 2-2 PHYSICAL INSTALLATION

Audimax III is designed to be mounted in a standard 19-inch-wide rack. The unit requires 3-1/2-inch-high front panel space and is slightly less than 10 inches deep. Install the unit in a reasonably well ventilated position, making certain that there is no high heat producing equipment beneath it. The ambient temperature should not exceed 130°F.

## 2-3 ELECTRICAL INSTALLATION

The Audimax III power supply is equipped with a power transformer permitting the selection of either 115-volt or 230-volt operation. If 230-volt operation is required, remove the jumpers on the power supply board from lugs 1 to 2 and 3 to 4. Reconnect a single jumper between lugs 2 and 3. Replace the fuse with a type 3AG-0.15 amp. fuse.

For broadcast applications, it is recommended that the Audimax III be installed at a studio or console and its output fed directly into the main audio line. Satisfactory operation requires that the unit be presented with a constant 600/150 ohm impedance throughout the audio band.

A fast acting peak limiter is recommended for use at the transmitter (following Audimax III). However, this peak limiter should be set to show only occasional limiting of 2 or 3 dB. For best results, a CBS Laboratories' Volumax should be used instead of a conventional peak limiter

#### NOTE

The master volume indicator should follow Audimax III. This will discourage unnecessary gain riding which might tend to defeat the automatic features of Audimax.

#### 2-4 ELECTRICAL CONNECTIONS

Input and output leads should be connected to the five-terminal strip at the rear of the chassis. Terminals 1 and 2 are the input, and terminals 4 and 5 are the output connections. The unit may be connected for balanced or unbalanced operation. Terminal 3 is the chassis ground. The standard Audimax III is delivered for 600-ohm operation. For 150-ohm operation special input and output pads may be installed and transformers T2 and T3 strapped as shown on the schematic diagram (see Figure 4.4 and 4.5). The fixed attenuator at the input terminals must also be removed or converted for 150-ohm operation.



## SECTION III

### SET-UP PROCEDURE

#### 3-1 LEVEL ADJUSTMENT

Audimax III is supplied with a 20 dB fixed pad at its input to accommodate the levels usually present at the output of consoles. The minimum input for full automatic control is -10 vu under these conditions. However, removal of this pad permits normal operation with input levels as low as -30 vu.

With proper input levels, average program material should cause the front panel meter to indicate approximately 0 dB gain, (this figure is relative and does not refer to actual gain of the amplifier). In this way, the advantages of +10 dB of level correction can be realized.

The INPUT LEVEL setting may be established by either of two methods:

- a. Use a recording or other program source and adjust the INPUT LEVEL control, as indicated above, until the average "0 dB" reading is achieved.
- b. An oscillator may be used in place of the usual program sources or connected directly to the Audimax III input. The oscillator output (at 1 kc) should be adjusted so as to result in a level 4 dB higher than the normal vu level of the line in which Audimax III is connected. The INPUT LEVEL control is then adjusted for the "0 dB" reading. When an oscillator is connected directly to Audimax III, it is important that proper impedance matching be observed and that no other loads are present on the line.

The OUTPUT LEVEL control is continuously variable over a 30 dB range to provide a maximum of 11 vu with normal program input.

### 3-2 VARIATIONS FROM STANDARD OPERATING PROCEDURES

Three variations from standard operating procedures should be observed when Audimax III is used:

- a. If the master volume indicator is properly installed at the Audimax III output, there will be little tendency for manual gain control at this point. In fact, the rule here should be "DON'T TOUCH!"
- b. At individual studios, however, where no Audimax III is in control it may be desirable at times to readjust levels slightly. This should be done slowly, whether the program level is too low or too high.
- c. A third change of procedure concerns "fades". Since Audimax III will defeat any slow deliberate reduction of level, all fades must be made more quickly than by usual methods. A little practice will easily result in the required skill. The most convenient way to insure proper procedures at all locations is to connect all cue lines to some point beyond the Audimax III output.

### 3-3 GATED GAIN STABILIZER

The function of the Gated Gain Stabilizer (GGS) is to make the following decision: Should the gain be increased when a lapse occurs in the audio? This is especially important for television and motion pictures where these lapses occur quite often. To prevent level increases of system noise or audio signals which are clearly background effects, the GGS

inhibits gain "recovery" during those intervals when the input level drops below a preset threshold.

The GGS threshold has been factory set to inhibit gain increase when the incoming signal has dropped approximately 14 dB below the normal line level. This figure has been established after extensive field experience, and represents a satisfactory value for typical broadcast use. For special applications the GGS threshold may be moved upwards towards normal program level by decreasing the value of R45A or lowered by increasing the value of this resistor. The following table gives suggested values:

GGS Threshold	R45A
-4 dB	120 ohms
-8 dB	220 ohms
-11 dB	430 ohms
-14 dB	680 ohms
-17 dB	2.4 k
-20 dB	open

Sine wave verification of the GGS threshold level may be accomplished by the following procedure:

- a. Feed a sine wave input to cause the front panel meter to read 0 dB gain reduction.
- b. Remove the signal and wait at least 15 seconds for full stabilization to occur.
- c. Reapply the input signal at a level below the desired threshold and slowly increase the signal until the front panel meter just

begins to deflect towards the right. The input level at this time should be approximately 5 dB less than that indicated by the above table. (This 5 dB difference is a special factor that must be considered when sine-wave calibration of the GGS threshold is performed).

#### 3-4 FUNCTION SWITCH

Audimax III is in operation performing automatic level control when the FUNCTION switch is at NORMAL position. Turning the switch to the TEST position causes the gain to hold constant at the same level as for normal operation. The function of the TEST position is to provide for overall system performance measurements.

#### 3-5 LIMITED DYNAMIC RANGE APPLICATIONS

The gain control action of the Audimax has been designed to provide a precise degree of control with a minimum of noticeable change in the original dynamic range. As a tool for the broadcaster, it provides maximum modulation consistent with artistically acceptable performance for a wide variety of program material. In some applications, however, it is practical and desirable to further limit program dynamic range. This is commonly done for the purpose of achieving higher average modulation, or a more uniform sound as in the case of public address systems. This effect may be achieved by decreasing the Audimax recovery time.

Although the total gain-increasing action of the Audimax is a complex function of many variables, one phase of the recovery characteristic may be modified by changing R76. This normally is a 10 megohm resistor

mounted on lugs on the Logic Board. By decreasing its value, the speed of recovery is increased. Typically, the resistance may be decreased to 5 megohms, although values as low as 1 megohm can be used in special applications.

### 3-6 STEREOPHONIC OPERATION

For two-channel stereophonic operation, two Audimax III units are coupled together by means of a stereophonic adapter board mounted in the upper chassis. The adapter employs resistive mixing of the left and right Audimax III output signals and controls each of the two Audimax IIIs with a signal proportional to the sum of left-plus-right. In this way, gain changes in both channels are identical, thus preserving the stereophonic perspective, as well as making the system responsive to the true volume level.

#### NOTE

The Monaural Audimax III units can not be modified for stereophonic operation in the field. If you anticipate going to stereo operation in the future, CBS Laboratories recommends the use of the Audimax IIIS which can be operated in a monaural mode until the changeover.

In the event that the incoming left and right channels are improperly phased with respect to each other, the coupling circuitry in the stereophonic adapter would provide a difference signal instead of a sum signal for control purposes. Since this difference signal is generally lower in level than the sum signal, Audimax gain would be unnecessarily high. To correct for this out-of-phase condition, a STEREO REVERSE switch is provided. The upper chassis in the stereophonic pair contains

a MODE switch to select either MONAURAL, STEREO or STEREO REVERSE operation. STEREO REVERSE operation corrects for an inadvertent phase reversal in the input line. MONAURAL operation permits independent usage of the two Audimax units. The FUNCTION switch works as previously described except that both left and right channel units are controlled by a single switch (S92) mounted on the lower chassis.

The INPUT LEVEL controls of the stereophonic Audimax units may be most conveniently adjusted by working with the MODE switch in the MONAURAL position. As previously indicated, a common 1 ke sine-wave input should be applied to both channels so as to result in a level 4 dB higher than the normal vu level of the lines in which the Audimax is inserted. When stereo operation is intended, adjust the INPUT LEVEL controls to produce front panel meter readings of approximately +6 dB. When the MODE switch is returned to the STEREO position, the gain in each unit should change to approximately 0 dB for normal operation.

In addition, because normal input levels are 6 dB lower in Stereo mode than in Monaural, R45A, the Gated Gain Stabilization threshold control has been removed thereby providing the additional 6 dB of GGS sensitivity required. For that reason, when switched to Monaural mode, the GGS threshold will be -20 dB rather than -14 dB relative to normal input level.

## SECTION IV

## THEORY OF OPERATION

## 4-1 GENERAL

Observe Audimax III block and schematic diagrams (Figures 4.1 through 4.4). Transistors  $Q_2$  through  $Q_9$ , together with input and output attenuators,  $R^8$  and  $R^{13}$ , and input and output transformers  $T_2$  and  $T_3$ , constitute a high-quality audio amplifier. All stages are operated in push-pull. A variolossor network, including  $CR_7$  and  $CR_8$ , obtains control voltage from the Audimax III Memory Unit. The signal attenuation of the variolossor is a function of the voltage applied to it. Thus, the overall system gain becomes a function of the output level, as determined by rectifier 1 and 2, and the input level determined by rectifier 3. Each rectifier is appropriately weighted with respect to charge and discharge speed to handle speech and music most effectively. For example, rectifier 2 is weighted to permit a more rapid discharge following a short impulsive signal, excessive with respect to the average, than would be true if there were merely a change in average level.

The attack time of Audimax III, i.e., the time required to effect a gain reduction when the signal level rises suddenly, is approximately 12 milliseconds and is dictated by the charge-up time of the rectifier 1 capacitor. The recovery time, i.e., the time required to effect a gain increase when the signal level drops, is a function of several variables. Audimax utilizes the "Platform" concept. Thus, instead of having a recovery action such that the control voltage tends to follow the amplitude contour





of the audio signal, audible peaks in the signal cause the gain to be set at a proper level, and a reduction of signal from these peaks over a suitable range will be accommodated without gain changes unless it becomes apparent that the average value has shifted. When an increase of gain is required to maintain constant output level, this change is effected within one or two seconds. The Gated Gain Stabilization feature of Audimax III allows discharge of the storage capacitor through R76, thus providing a slow upward drift towards "Platforms" of higher gain, only during that time when program is present.

The Input Reference, driven by rectifier 3, feeds a third input to the Recovery "AND" circuit. As long as this input is positive, the additional slow recovery mode is in effect. However, during a lapse of audio, this input is at -2 volts. Under these conditions, the Recovery "AND" circuit is inhibited and R76 is electrically disconnected from the storage capacitor. Thus, the system gain is held constant during pauses until the Input Reference returns to a positive voltage condition. The gentle action provided by R76 is especially useful for improving average modulation levels. This action is completely separate from the normal gain riding activities of Audimax III and will not be objectionable under normal circumstances. If for special applications, it is deemed desirable to speed up this phase of the recovery characteristic, R76 may be decreased in value. (See Limited Dynamic Range Applications, Page 3-4).

The Input Reference also feeds a 10 second time delay which is coupled to the control voltage bus via an "OR" circuit. If audio should lapse for a period longer than 10 seconds, and if the system gain is greater

than 0 dB, the gain will automatically return to 0 dB. This places the system in a proper standby condition to await the resumption of audio.

#### 4-2 CIRCUIT OPERATION

The input signal is applied through the input attenuators R8 and R9, and input transformer T2. The signal at the secondary winding of T2 is amplified by the push-pull class A amplifier stages Q2 - Q3 and Q4 - Q5. The coupling circuit between these stages contains the variolossor elements CR7 and CR8. These matched diodes present an attenuating path whose impedance is determined by the control voltage applied through R24. Control voltage, taken from potentiometer R68, controls the variolossor and therefore the amplifier gain.

To minimize distortion, the output transformer T3 is fed by a Class A push-pull amplifier Q8-Q9, driven by push-pull emitter-followers Q6-Q7. Output is then fed through the 600-ohm T-pad, R43, to the output terminals.

Step up winding 1 - 5 of T3 is capacity coupled to diodes CR17 and 18 whose cathodes are biased at +16 V. Program signal is rectified by them and the storage capacitor located within the Memory Unit is negatively charged through R79. The control line is connected to the grid of the cathode follower V1, which presents negligible loading of the storage capacitor and provides a low impedance voltage source to the variolossor.

Figure 4.2 is a composite functional diagram illustrating the steady-state interrelationships among the several elements of the Audimax III System. The upper left quadrant indicates the relative gain of the variolossor (in decibels) as a function of control voltage. The lower left



quadrant indicates the outputs of rectifiers 1 and 2 (see Figure 4.2) as a function of Audimax III output level. The voltage across the storage capacitor developed by biased rectifier 1 (CR17, CR18) is shown by curve OJGH. The voltage developed by rectifier 2 (CR15, CR16) and fed to the comparator is shown by curve OJKQ. Rectifier 2 is biased with +7.5 volts.

Control voltage to V1 is obtained either from rectifier 1 or rectifier 2 depending upon which is less negative. This is determined by the comparator.

Referring now to the lower right quadrant of Figure 4.2, below an input of -24 dBm (with R8 fully clockwise) Audimax III has a constant gain of 30 dB. This is represented by section OA of the input-output curve. As the input is increased from -24 dBm to -16 dBm, the gain is maintained constant because, although rectifier 2 has developed about -8 volts, rectifier 1 output is zero, and being less negative than rectifier 2, therefore controls the gain. Thus, examining the upper right quadrant of Figure 4.2, Audimax III gain vs. input, the gain remains constant along FLM. As the input is further increased, rectifier 1 begins to develop negative dc along line GH, and since rectifier 2 output JKQ is more negative, control remains with rectifier 1. Audimax III gain follows line MN, and the output is determined by line BC.

When the input has reached +4 dBm, the output is +16.5 dBm and the normalized gain reduction is 17.5 dB. If the input is now reduced, rectifier 1 output will not become less negative because charge is retained by the Recovery "AND" circuit. Rectifier 2 output, however, will be

reduced quickly. Thus, as the input drops from 0 dBm to -1 dBm, the gain remains constant (line NP), output follows line CD, control voltage to V1 remains constant along HK while rectifier 2 output drops along QK.

As the input is reduced below -1 dBm, however, rectifier 2 output becomes less negative than rectifier 1 output, and gain control reverts to rectifier 2. Thus, the gain increases following line PL and the output follows line DA because both rectifiers 1 and 2 move along KJ. When the input is reduced below -20 dBm, Audimax becomes a constant gain amplifier.

Figure 4.2 may be used to determine Audimax III behavior for both ascending or descending input signals by the method of projection along the four sets of curves utilizing the rule of precedence indicated above, i.e., control is vested in either rectifier 1 or rectifier 2 depending upon which has a less negative output.

Bear in mind that the description given above pertains only to the steady-state performance of Audimax III. The transient behavior of the system modifies this performance to produce artistically acceptable automatic control.

#### 4-3 GATED GAIN STABILIZATION

To prevent Audimax III from seeking its maximum gain due to a lapse of audio greater than two seconds, such as occurs in TV and motion pictures, Gated Gain Stabilization is employed. In the discussion to follow, the term "lapse of audio" refers to a condition where the input signal is below that determined by the GGS threshold control, R45A.

Referring to Figure 4.4, the signal from the collectors of Q2, Q3 is fed to emitter-followers, Q14, Q15 and then to an amplifier consisting of Q10 - Q13. R15, in the base circuit of Q10, Q11, forms a voltage divider with R14 and R16 thereby serving as the Gated Gain Stabilizer threshold control.

The push-pull output of Q12 and Q13 drives rectifier 3 whose dc voltage (at terminal F of the GGS printed circuit board) is applied to the Input Reference. Figure 4.2 indicates the output of rectifier 3 (with R15A = 680-ohms) as curve RST covering both lower quadrants. Values of rectifier 3 output shown in the lower right quadrant are positive and those in the lower left quadrant are negative. For example, if rectifier 1 output were -1 volt and rectifier 2 output were -10 volts, rectifier 3 output would be about +1.5 volts. Rectifier 3 determines the voltage at the output of rectifier 2 whenever rectifier 2 is less negative than rectifier 3. If the input signal were suddenly removed without rectifier 3 in the circuit, the control voltage would soon return to zero. However, with rectifier 3 output at -2 volts, rectifier 2 will rise from -9 volts to -2 volts and then relinquish control to rectifier 3. Since rectifier 3 remains at -2 volts, rectifier 1 output must remain at -2 volts, and the amplifier gain is held constant until a signal returns to cause rectifier 3 output to become positive with respect to rectifier 1. Since the speed with which rectifier 3 output is changed is very rapid in comparison with the operating speeds of the other rectifiers, it assumes rapid control when signal changes occur requiring such action. Its behavior may be likened to an electronic "gate" which either inhibits or permits gain increases, depending upon the input signal level.

#### 4-4 FUNCTION SWITCH AND METER

In the NORMAL position of the FUNCTION switch, Audimax III is in operation and the GAIN meter monitors the cathode voltage of V1. Since negative control voltage to V1 reduces the cathode voltage and increases the attenuation of the variolossler, the meter is calibrated to indicate the relative gain of the amplifier.

In TEST position, the FUNCTION switch connects the control line to a potential providing a constant grid-cathode voltage at V1 and therefore constant gain to the amplifier. This voltage has been selected to duplicate the normal gain of Audimax III.

#### 4-5 STEREOPHONIC ADAPTER

Figure 4.3 is a schematic diagram of the Audimax III Stereophonic Adapter circuitry. This board is mounted, together with the MODE switch, in the left (upper) channel unit of two essentially identical Audimax IIIs for use in stereophonic operation.

In STEREO position, output signals from the two units are coupled via capacitor pairs C10 and C11 to the Stereo Adapter printed circuit board where resistive mixing is employed to produce a push-pull Left-plus-Right signal. This sum signal is then fed to T91 by the Class A push-pull amplifier Q91, Q92. Step-up winding 1-5 provides a parallel feed to the control circuitry of each Audimax via capacitors C91-C94. Since the control for the Left and Right Channel Audimax IIIs is being obtained from a sum signal, it must be realized that, when both channels are fed identical signals, gain control will occur at an input 6 dB below that

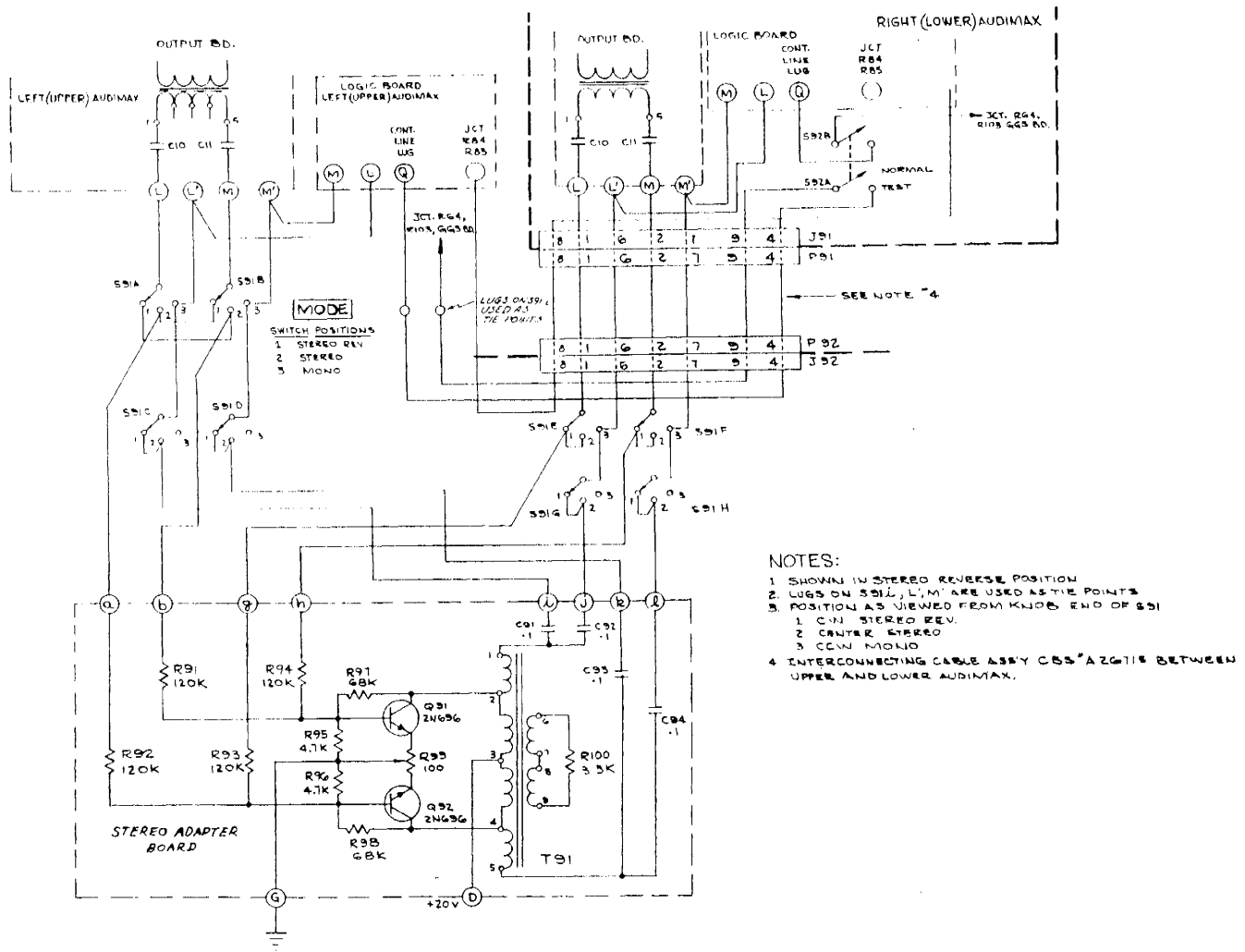

FIGURE 4.3 STEREOPHONIC ADAPTER SCHEMATIC DIAGRAM



indicated in Figure 4.2, thereby producing an output 6 dB below the normal output of a monaural Audimax III.

STEREO REV position reverses the phase of the signal from the left (upper) Audimax to correct for improper phasing of the incoming left and right channel signals.

In MONO position of the MODE switch, both units are restored, except for the TEST function, which is controlled by the FUNCTION switch in the lower Audimax, to normal independent operation.

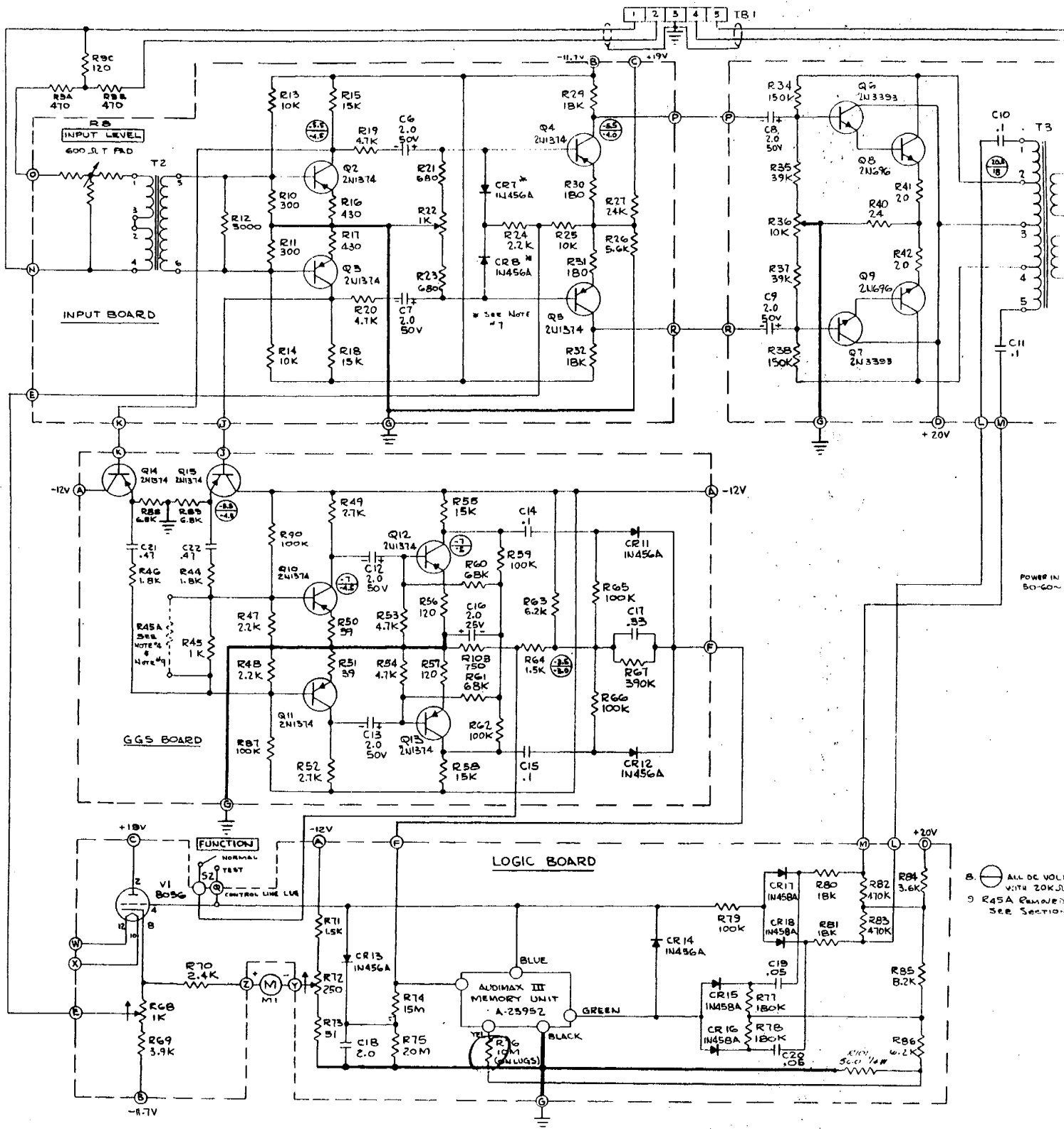

B.  $\ominus$  ALL DC VOLTS WITH 20K Ω  
 9 R45A REMOVED SEE SECTION

FIGURE

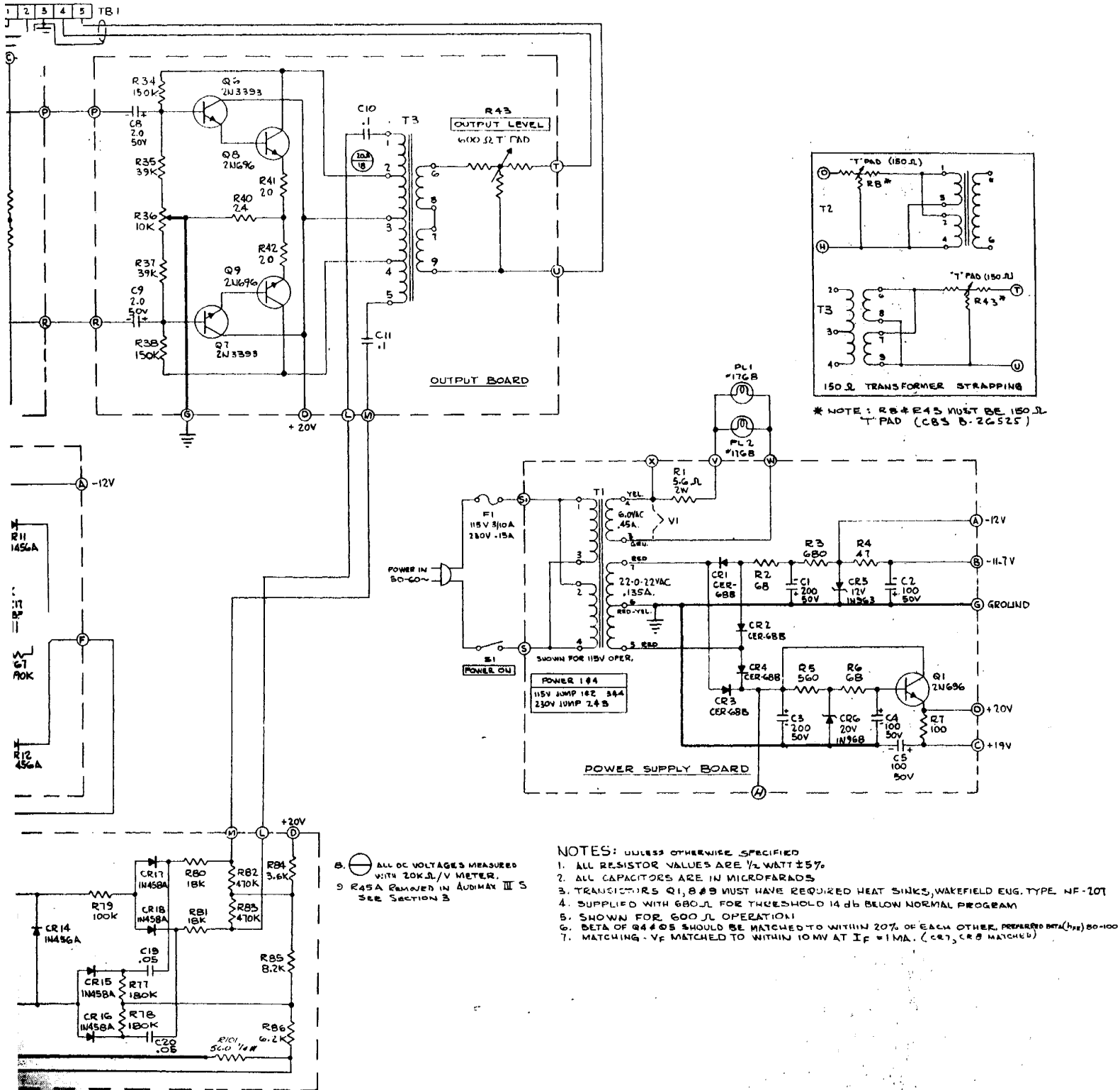
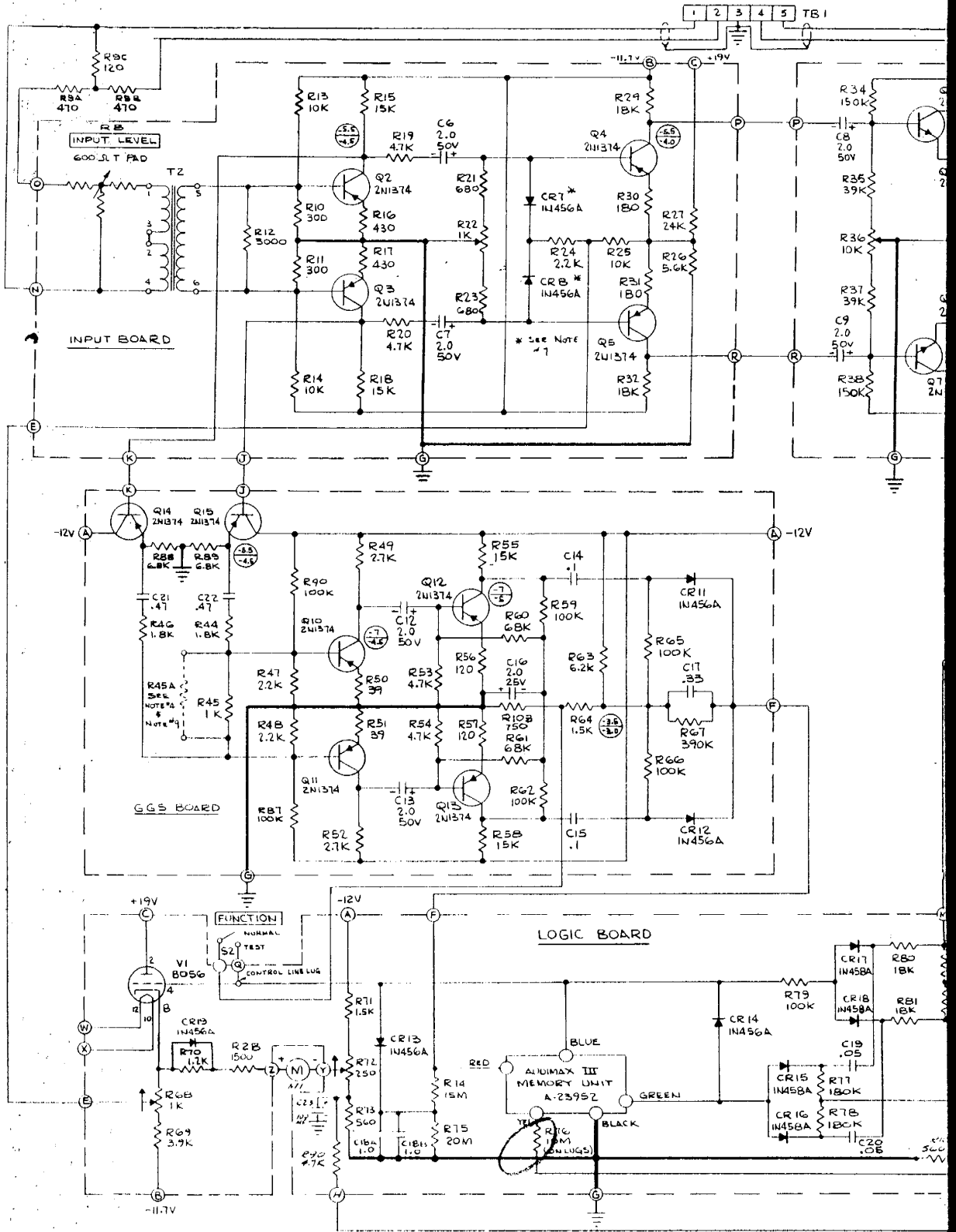

FIGURE 4.4 AUDIMAX III, MODEL 444, SERIAL NUMBERS 101 THROUGH 200, SCHEMATIC DIAGRAM



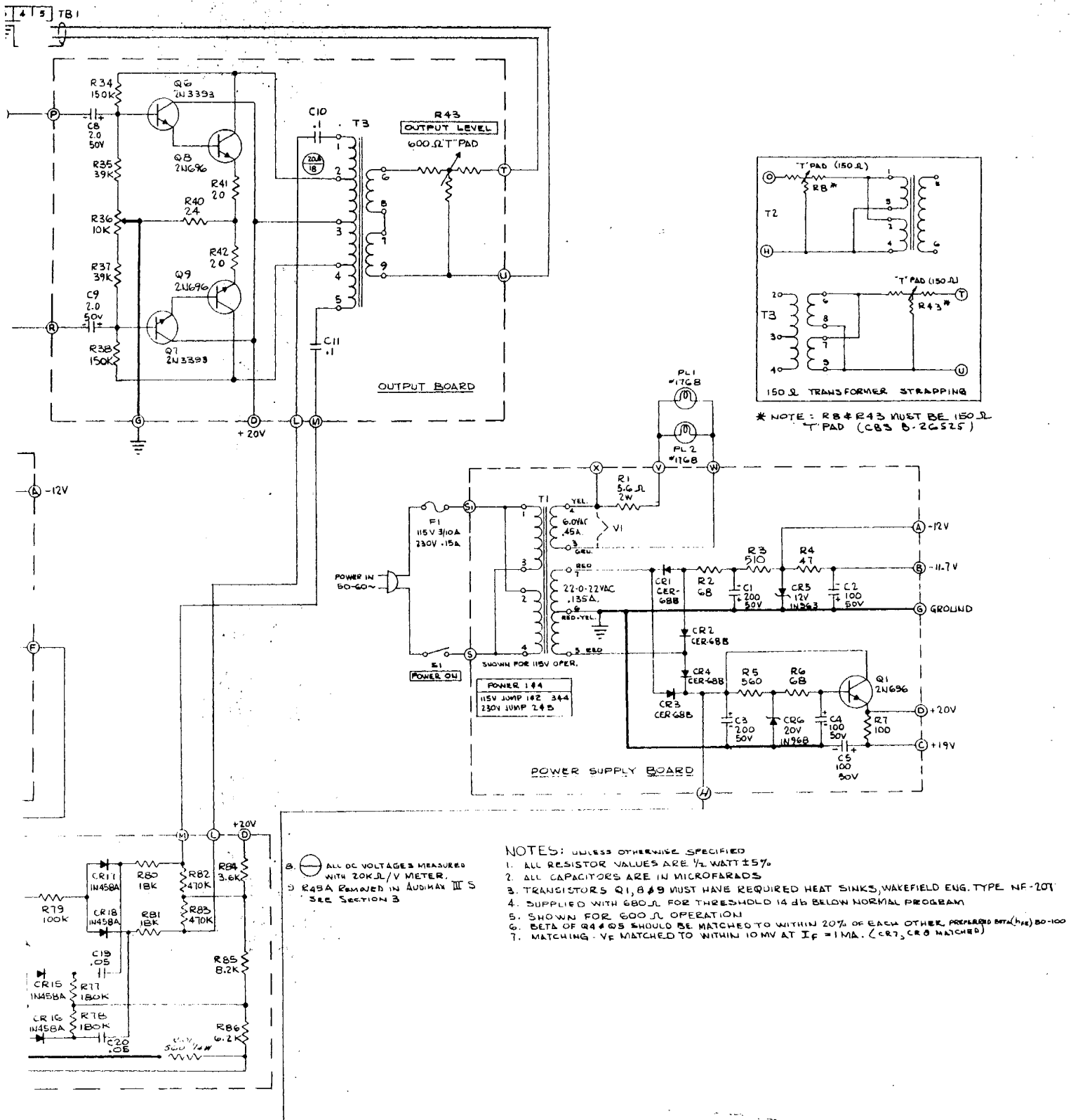

FIGURE 4.5 AUDIMAX III, MODEL 444, SERIAL NUMBERS 201 AND ABOVE, SCHEMATIC DIAGRAM

## SECTION V

## MAINTENANCE

## 5-1 GENERAL

Troubleshooting for any apparent malfunction of the Audimax III should begin with a check of the power supply\*. DC voltages, as measured with a multimeter rated at 20,000 ohms per volt or greater, should fall between the upper and lower limits as shown on the schematic diagram. Accidental shorting of the +20 V supply could cause Q1 to develop a collector-emitter short thereby impressing an unregulated 28 V at point D. If this transistor is replaced, do not neglect to install the heatsink on the new transistor. Check for open decoupling capacitors in the event of excessive 120-Hz hum. If the power supply functions properly, proceed with the following recommended checks for possible troubles.

In the extreme case - no output at all - check your input and output connections thoroughly. Inspect the harness connection to the printed circuit boards for a possible open lead. If this visual inspection does not uncover any defects, stage by stage checking of the unit is necessary. The collector dc voltages of each stage should be checked before any signal tracing is attempted.

## 5-2 SERVICING THE MAIN AMPLIFIER

An input signal of -18 dBm (0.1v) at 1 kc may be used for signal tracing the main amplifier channel. Since this level is below the threshold of

\* The Audimax III is designed for operation with a 600-ohm load. A standard 620-ohm resistor may be used during bench check.

gain reduction, the amplifier should provide 30 dB of gain from input to output terminals, with the GAIN meter reading 110. To insure maximum gain, short the "control line lug" to ground.

#### NOTE

Care should be taken to have the FUNCTION switch in NORMAL position whenever the control line is grounded to prevent possible damage to the GAIN meter.

This lug is located at the top of the logic board adjacent to the Memory Unit. Frequency response is also most conveniently measured at this level, although response is flat at all levels.

The signal at points P and R on the input board should be about 0.15 volts rms measured with a VTVM to ground. If this voltage appears to be incorrect, localize the trouble by removing the harness leads from points P and R. The voltage at these points should now measure 0.45 volts. Obtaining the correct reading in this unloaded condition would indicate proper functioning of the Input board and, therefore, a malfunction of the Output board. However, if this measurement does not check, then further checking of the Input board is required.

With the input maintained at 100 millivolts, the following approximate signal voltages to ground should be present: Q2 and Q3 collectors, 35 millivolts; the bases of Q4 and Q5, 7 millivolts. With correct voltages at Q2 and Q3, but incorrect at Q4 and Q5, remove the harness lead from point E and observe that the level at Q4 and Q5 bases does not increase by more than 1 dB. Excessive level increase would indicate a malfunction or improper calibration of the logic board. If transistors Q4 and Q5 are defective, replace them with units with beta matched within

20% of each other. If it is not practical to match betas, select a replacement transistor such that the collector voltages of  $Q_1$  and  $Q_2$  differ by less than 1 V dc.

Diodes CR7 and CR8 are matched. To match a replacement diode, feed 1 milliamperes from a regulated power supply through a high resistance in series with the diode. Forward voltage drop across the diode under test must be within 10 millivolts of the other diode under the same condition.

If any of the semiconductor devices on the Input board are replaced, it will be necessary to readjust R22 and R68 as follows: Turn the INPUT and OUTPUT LEVEL controls and R68 fully clockwise. Feed a 5 kc signal at -6 dBm and adjust R68 to produce a 0 dB reading on the GAIN meter. The output should be +15 dBm. Connect a distortion analyzer across the output and adjust R22 for minimum distortion.

Replacing Q6, Q7, Q8 or Q9 will necessitate the readjustment of R36. Feed a 50 Hz signal to deflect the GAIN meter to the green region and adjust R36 for minimum output distortion.

### 5-3 SERVICING THE GATED GAIN STABILIZER

Troubleshooting of the Gated Gain Stabilizer (GGS) and the logic board can be facilitated by the use of Figure 4.2. It is very important, however, that all dc measurements be performed with a VVM of 10 megohms or greater input impedance.

With no input signal applied to Audimax III, -2 volts dc should be present at point F of the GGS printed circuit board. Monitor this point and feed a 1 kc signal at -28 dBm with the INPUT LEVEL control R8, fully clockwise. Increase the input slowly and observe that point F becomes positive at



approximately -20 dBm. With this input, 0.025 volts rms to ground should be present at the emitters of Q14, Q15 producing approximately 0.060 volts at Q10, Q11 collectors.

#### 5-4 SERVICING THE LOGIC BOARD AND MEMORY UNIT

##### CAUTION

Be careful when making these tests. The Memory Unit can be permanently damaged if the voltmeter probe shorts these points to other voltages.

The solid state Memory Unit has been encapsulated in epoxy for maximum stability and protection. No attempt should be made to open it; all test measurements can be made at appropriate connection points. Before undertaking any tests of the Memory Unit, first be sure that the main amplifier and Gated Gain Stabilizer are functioning properly.

To test the steady-state performance of the Logic board and Memory Unit, turn the INPUT LEVEL control fully clockwise. An input of -6 dBm at 1 kc should produce -1 volt at the control line (BLUE connection to the Memory Unit) and -9 volts at the GREEN connection.

With R68 correctly calibrated there should be -1 volt at point E which will produce approximately 10 dB of gain reduction in the variolosses. To observe the relinquishing of control by rectifier 2 to rectifier 3, slowly decrease the input to -30 dBm while monitoring the voltage at the Memory Unit GREEN connection. This voltage will rise from -9 volts towards 0 but should then begin to increase negatively, at approximately -20 dBm, when rectifier 3 becomes more negative than rectifier 2. It is

important that the above measurements be made with a vacuum tube voltmeter with an input impedance of at least 10 megohms.

The steady-state voltage relationships are graphically shown in Figure 4.2. If, for some reason, it is necessary to replace V1, then R72 and R68 will require recalibration. To set R72 short to ground the "control line lug", located at the top of the Logic board adjacent to the Memory Unit, and adjust for a +10 dB reading of the GAIN meter. R68 can then be set by feeding -6 dBm at 1 kc to Audimax III, with the HI-FID LEVEL control fully clockwise, and adjusting for a 0 dB reading on the GAIN meter.

#### 5.5 TRANSIENT PERFORMANCE

To check transient performance, turn R43 fully clockwise and feed a 1 kc signal so as to produce a GAIN meter reading between -5 and -10 dB. This should result in an output level of +16 dBm.

Rapidly reduce the input signal exactly 20 dB. Recovery to maximum gain should occur in two steps: after an initial delay, quickly to a reading of approximately +5 dB, then slowly to +10 dB. This fast mode of recovery is typical of the speed at which gain is increased when program levels exceed the lower boundaries of the "platform". The slower recovery mode is equivalent to that speed at which a drift towards "platforms" of higher gain occurs. This latter time-constant is controlled by R76, and the above description only applies when R76 is unchanged from its original value of 10 megohms.

After the gain has stabilized at maximum, short out the input signal and watch the GAIN meter. Gain should remain constant for at least 10 seconds and then slowly return to the normal region.

Next, restore the previous full input signal level, resulting in a gain reading between -5 and -10 dB. Short out the input signal and observe that the gain will recover to -5 dB with no further change.

To verify correct operation of Gated Gain Stabilizer, feed a 1 kc signal to produce a reading of 0 dB on the GAIN meter. Quickly reduce the input 20 dB. The meter should not move out of the green region. Increase the input 5 dB and observe that the meter moves out of the green region towards maximum gain.

This check is only valid for  $R_{15A} = 680$  ohms as factory supplied. If this value has been changed to alter the Gated Gain threshold, the performance check must be changed accordingly.

#### 5-6 BULB REPLACEMENT

Meter lamps PL1 and PL2 are rated at 6 volts, but are operated at only 4 volts to provide extremely long life. If, however, replacement becomes necessary, removal of the lamp holders is facilitated by the access holes located directly behind the sockets in the card holder.

SECTION VI

PARTS LIST

AUDIMAX IEE

<u>Ref. (Symbol)</u>	<u>Description</u>	<u>Manufacturer &amp; Part No.</u>
<u>Capacitors</u>		
C1, C3	Electrolytic 200 MF 50 V	TELE-HEC-200-K-0
C2, C4, C5, C3XX	Electrolytic 100 MF 50 V	TELE-HEC-100-L-0
C6, C7, C8, C9 C12, C13, C16	Electrolytic 2 MF 50 V	TELE-HEC-2-L-1 or Aerovox--BCD-50002
C10, C11, C14, C15	Dipped Mylar .1 MF 100 V <u>±10%</u>	Elmenco--1DE-2-104
C17	Dipped Mylar .33 MF 100 V <u>±10%</u>	Elmenco--1DE-4-334
C18AX, C18BX	Dipped Mylar 1.0 MF 100 V <u>±10%</u>	Elmenco--1DE-5-105
C19, C20	Dipped Mylar .05 MF 100 V <u>±10%</u>	Elmenco--1DE-2-503
C21, C22	Dipped Mylar .47 MF 100 V <u>±10%</u>	Elmenco--1DE-4-474
<u>Diodes</u>		
CR1, CR2, CR3, CR4	Silicon Rectifier 250 MA 100 PIV	Solidron--CER-68B
CR5	Silicon Zener 1N963B 12 V <u>±5%</u> .1 W	Motorola or equiv.
CR6	Silicon Zener 1N963B 20 V <u>±5%</u> .1 W	Motorola or equiv.
CR7*, CR8*, CR11, CR12, CR13, CR14, CR19**	Silicon, 1N454A	Texas Inst. or equiv.
CR15, CR16, CR17, CR18	Silicon, 1N458A	Texas Inst. or equiv.
<u>Transistors and Muistor</u>		
Q1, Q3, Q9	2N696	Texas Inst. or equiv.
Q2, Q3, Q4 <sup>+</sup> , Q5 <sup>+</sup> , Q10, Q11, Q12, Q13, Q14, Q15	2N1374	Texas Inst. or equiv.
Q6, Q7	2N3396	GE
V1	8056	RCA

\*CR7, CR8 matched to within 20%  
 \*\*DC Beta matched to within 20%

<u>Ref. (Symbol)</u>	<u>Description</u>	<u>Manufacturer &amp; Part No.</u>
	<u>Resistors</u>	
	Note: All resistors carbon composition 1/2 W +5% Allen-Bradley or equivalent, unless otherwise specified.	
R1	5.6 ohm 2W wirewound	IRC--BWH
R2	68 ohm	
R3 <sup>+</sup> , R21, R23, R45A	680 ohm	
R4	47 ohm	
R5, R73**	560 ohm	
R6	68 ohm	
R7	100 ohm	
R8, R43	600 ohm T-pad (WW) 150 ohm T-pad (optional)	CBS B23982 CBS B26525
R9A, R9B	470 ohm	
R10, R11	300 ohm	
R9C, R56, R57	120 ohm	
R12	3 K	
R13, R14, R25	10 K	
R15, R18, R55, R58	15 K	
R16, R17	430 ohm	
R19, R20, R53, R54, R102**	4.7 K	
R22, R68	Pot 1 K $\pm 20\%$ 1/6W	Mallory MTC-1
R24, R47, R48, R64	2.2 K	
R26	5.6 K	
R27	24 K	
R28**, R44, R46	1.8 K	
R29, R32, R80, R81	18 K	
R30, R31	180 ohm	
R34, R38	150 K	
R35, R37	39 K	
R36	Pot 10 K $\pm 20\%$ 1/6 W	Mallory MTC-1
R40	24 ohm	

<sup>+</sup> models 101 through 200, R3 = 680 ohm  
models 201 and above, R3 = 510 ohm

<u>Ref. (Symbol)</u>	<u>Description</u>	<u>Manufacturer &amp; Part No.</u>
R41, R42	20 ohm	
R45	1 K	
R49, R52	2.7 K	
R50, R51	39 ohm	
R59, R62, R65, R66, R79, R87, R90	100 K	
R60, R61	68 K	
R63, R86	6.2 K	
R67	390 K	
R69	3.9 K	
R70**	1.2 K	
R71, R88**	1.5 K	
R72	Pot. 250 ohm 1/6 W <u>±20%</u>	Mallory MTC-1
R74	15 Meg	
R75	20 Meg	
R76	10 Meg	
R77, R78	180 K	
R82, R83	470 K	
R84	3.6 K	
R85	8.2 K	
R88, R89	6.8 K	
R101	560 ohm 1/4 W <u>±5%</u>	
R103	750 ohm	
<u>Misc. and Electrical</u>		
F1	Fuse 3 Ag 3/10 A (115 V) .15 A (230 V)	Littlefuse or equiv.
S1, S2	Switch SPST	C-H 8381 K7
T1	Power Transformer	CBS 23936F
T2	Input Transformer	CBS 23935
T3	Output Transformer	CBS 23934-2

<u>Ref. (Symbol)</u>	<u>Description</u>	<u>Manufacturer &amp; Part No.</u>
	<u>Misc. and Electrical</u>	
PL1, PL2	Lamp #1768	GE or Tungsol
TB-1	Barrier Strip (5 Term)	Jones 5-140-Y
M-1	Meter "GAIN"	CBS A-26664C
	Lamp Holders (2)	Lee Craft 16-26
	Heat Sinks	Wakefield Eng. NF-207
	Fuse Post	Littlefuse 342012
	<u>Complete Assemblies</u>	
	Power Supply Board	CBS C23958-ASY
	Input Board	CBS C23957-2-ASY
	Output Board	CBS C23959-ASY (A3)
	GG5 Board	CBS C23953-ASY
	Logic Board	CBS C23954-ASY
	Memory Unit	CBS A23952-ASY

\*\*Values shown for units with serial nos. above 201.  
 For serial nos. below 201 values differ as follows:

- R28 = Omitted
- R70 = 2.4 K
- R73 = 51 ohm
- R102 omitted
- C18 = 2.0 MFD
- CR19 omitted
- C23 omitted

PARTS LIST  
STEREOPHONIC ADAPTER

<u>Ref. (Symbol)</u>	<u>Description</u>	<u>Manufacturer &amp; Part No.</u>
C91, C92, C93, C94	Cap, Mylar .1 MF 100 V $\pm 10\%$	Elmenco-- 1DP-2-104
Q91, Q92	Transistor 2N696	Texas Inst. or equiv.
T91	Transformer (output driver)	CBS--A23934-2
R91, R92, R93, R94	Resistor 120 K 1/2 W $\pm 5\%$	A-B
R95, R96	Resistor 4.7 K 1/2 W $\pm 5\%$	A-B
R97, R98	Resistor 68 K 1/2 W $\pm 5\%$	A-B
R99	Pot 100 ohm 1/6 W $\pm 20\%$	Mallory MTC-1
R100	Resistor 3.3 K 1/2 W $\pm 5\%$	A-B
S91	Switch Rotary "MODE"	Mallory Grigsby--12M1333G
	Connectors (chassis) (2)	Cannon or Cinch -- DE9P
	Connector (Cable) (2)	Cannon or Cinch -- DE9S
	Hood (2)	Cannon or Cinch -- DE1997-5
	Bracket (Front Mounting) (2)	CBS--B26572
	Strap Rear Supporting (2)	CBS--B26573
S92	Switch, "FUNCTION" (Installed in lower Audimax)	C-H--8360-K8
	Board Assembly	CBS--26642 (asy)